

FOURTH EDITION

A TEXTBOOK OF

# STRENGTH OF MATERIALS

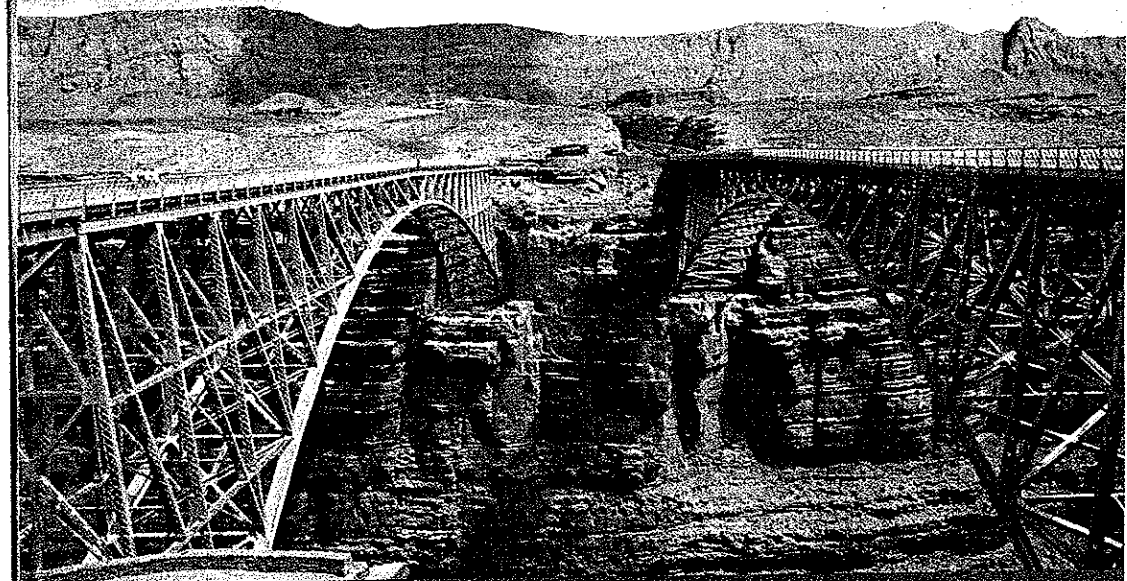

Dr. R.K. Bansal

# A TEXTBOOK OF STRENGTH OF MATERIALS

(In S.I. Units)

[For Degree, U.P.S.C. (Engg. Services), Gate and  
other Competitive Examinations]

*By*

**Dr. R.K. Bansal**

B.Sc. Engg. (Mech.), M. Tech., Hons. (I.I.T., Delhi)

Ph.D., M.I.E. (India)

Formerly Professor and Head

Department of Mechanical Engineering,

(University of Delhi)

Delhi College of Engineering, Delhi

**LAXMI PUBLICATIONS (P) LTD**

BANGALORE • CHENNAI • COCHIN • GUWAHATI • HYDERABAD  
JALANDHAR • KOLKATA • LUCKNOW • MUMBAI • RANCHI  
NEW DELHI • BOSTON, USA

*Published by :*  
LAXMI PUBLICATIONS (P) LTD  
113, Golden House, Daryaganj,  
New Delhi-110002

*Phone :* 011-43 53 25 00  
*Fax :* 011-43 53 25 28

[www.laxmipublications.com](http://www.laxmipublications.com)  
[info@laxmipublications.com](mailto:info@laxmipublications.com)

*Compiled by : Smt. Nirmal Bansal*

*© All rights reserved with the Author and Publishers. No part of this publication may be reproduced, stored in a retrieval system, or transmitted in any form or by any means, electronic, mechanical, photocopying, recording or otherwise without the prior written permission of the publisher.*

*Price : Rs. 450.00 Only.*

*Third Edition : 1996*  
*Reprint : 1998, 2000, 2001, 2002, 2003, 2004*  
*Fourth Edition : 2007, 2008, 2009*

#### OFFICES

##### India

© Bangalore 080-26 61 15 61  
© Chennai 044-24 34 47 26  
© Cochin 0484-239 70 04  
© Guwahati 0361-254 36 69, 251 38 81  
© Hyderabad 040-24 65 23 33  
© Jalandhar 0181-222 12 72  
© Kolkata 033-22 27 43 84  
© Lucknow 0522-220 95 78  
© Mumbai 022-24 91 54 15, 24 92 78 69  
© Ranchi 0651-221 47 64

##### USA

**Boston**  
11, Leavitt Street, Hingham,  
MA 02043, USA

ESM-0598-450-STRENGTH OF MATERIALS

*Typeset at : Goswami Printers, Delhi.*

C-17030/09/01

*Printed at : Giriraj Offset Printer, Delhi.*

*Dedicated*  
*to*  
*The loving memory of my daughter, Babli*

# Contents

Chapter	Pages
<b>Chapter 1. Simple Stresses and Strains</b>	<b>1—58</b>
1.1. Introduction	1
1.2. Stress	2
1.3. Strain	2
1.4. Types of Stresses	5
1.5. Elasticity and Elastic Limit	6
1.6. Hooke's Law and Elastic Moduli	6
1.7. Modulus of Elasticity (or Young's Modulus)	6
1.8. Factor of Safety	6
1.9. Constitutive Relationship between Stress and Strain	14
1.10. Analysis of Bars of Varying Sections	24
1.11. Analysis of Uniformly Tapering Circular Rod	27
1.12. Analysis of Uniformly Tapering Rectangular Bar	30
1.13. Analysis of Bars of Composite Sections	42
1.14. Thermal Stresses	44
1.15. Thermal Stresses in Composite Bars	50
1.16. Elongation of a Bar Due to its Own Weight	51
1.17. Analysis of Bar of Uniform Strength	53
<i>Highlights</i>	54
<i>Exercise 1</i>	
<b>Chapter 2. Elastic Constants</b>	<b>59—84</b>
2.1. Introduction	59
2.2. Longitudinal Strain	59
2.3. Lateral Strain	60
2.4. Poisson's Ratio	62
2.5. Volumetric Strain	68
2.6. Volumetric Strain of a Cylindrical Rod	70
2.7. Bulk Modulus	70
2.8. Expression for Young's Modulus in Terms of Bulk Modulus	73
2.9. Principle of Complementary Shear Stresses	74
2.10. Stresses on Inclined Sections when the Element is Subjected to Simple Shear Stresses	76
2.11. Diagonal Stresses Produced by Simple Shear on a Square Block	77
2.12. Direct (Tensile and Compressive) Strains of the Diagonals	78
2.13. Relationship between Modulus of Elasticity and Modulus of Rigidity	81
<i>Highlights</i>	82
<i>Exercise 2</i>	

<i>Chapter</i>	<i>Pages</i>
<b>Chapter 3. Principal Stresses and Strains</b>	<b>85—142</b>
3.1. Introduction	85
3.2. Principal Planes and Principal Stresses	85
3.3. Methods of Determining Stresses on Oblique Section	85
3.4. Analytical Method for Determining Stresses on Oblique Section	85
3.5. Graphical Method for Determining Stresses on Oblique Section	123
3.6. Mohr's Circle	128
<i>Highlights</i>	138
<i>Exercise 3</i>	139
 <b>Chapter 4. Strain Energy and Impact Loading</b>	 <b>143—169</b>
4.1. Introduction	143
4.2. Some Definitions	143
4.3. Expression for Strain Energy Stored in a Body when the Load is Applied Gradually	143
4.4. Expression for Strain Energy Stored in a Body when the Load is Applied Suddenly	145
4.5. Expression for Strain Energy Stored in a Body when the Load is Applied with Impact	152
4.6. Expression for Strain Energy Stored in a Body due to Shear Stress	165
<i>Highlights</i>	166
<i>Exercise 4</i>	167
 <b>Chapter 5. Centre of Gravity and Moment of Inertia</b>	 <b>170—234</b>
5.1. Centre of Gravity	170
5.2. Centroid	170
5.3. Centroid or Centre of Gravity of Simple Plane Figures	170
5.4. Centroid (or centre of gravity) of Areas of Plane Figures by the Method of Moments	170
5.5. Important Points	172
5.6. Area Moment of Inertia	194
5.7. Radius of Gyration	195
5.8. Theorem of the Perpendicular Axis	195
5.9. Theorem of Parallel Axis	196
5.10. Determination of area Moment of Inertia	197
5.11. Mass Moment of Inertia	211
5.12. Determination of Mass Moment of Inertia	212
5.13. Product of Inertia	218
5.14. Principal Axes	219
5.15. Principal Moments of Inertia	220
<i>Highlights</i>	228
<i>Exercise 5</i>	229

<i>Chapter</i>	<i>Pages</i>
<b>Chapter 6. Shear Force and Bending Moment</b>	<b>235—291</b>
6.1. Introduction	235
6.2. Shear Force and Bending Moment Diagrams	235
6.3. Types of Beams	235
6.4. Types of Load	236
6.5. Sign Conventions for Shear Force and Bending Moment	237
6.6. Important Points for Drawing Shear Force and Bending Moment Diagrams	238
6.7. Shear Force and Bending Moment Diagrams for a Cantilever with a Point Load at the Free End	239
6.8. Shear Force and Bending Moment Diagrams for a Cantilever with a Uniformly Distributed Load	242
6.9. Shear Force and Bending Moment Diagrams for a Cantilever Carrying a Gradually Varying Load	250
6.10. Shear Force and Bending Moment Diagrams for a Simply Supported Beam with a Point Load at Mid-point	252
6.11. Shear Force and Bending Moment Diagrams for a Simply Supported Beam with an Eccentric Point Load	254
6.12. Shear Force and Bending Moment Diagrams for a Simply Supported Beam Carrying a Uniformly Distributed Load	256
6.13. Shear Force and Bending Moment Diagrams for a Simply Supported Beam Carrying a Uniformly Varying Load from Zero at Each End to $w$ Per Unit Length at the Centre	264
6.14. Shear Force and Bending Moment Diagrams for a Simply Supported Beam Carrying a Uniformly Varying Load from Zero at one End to $w$ Per Unit Length at the Other End	266
6.15. Shear Force and Bending Moment Diagrams for Overhanging Beams	270
6.16. Shear Force and Bending Moment Diagrams for Beams Carrying Inclined Load	279
6.17. Shear Force and Bending Moment Diagrams for Beams Subjected to Couples	284
6.18. Relations between Load, Shear Force and Bending Moment	287
<i>Highlights</i>	288
<i>Exercise 6</i>	289
 <b>Chapter 7. Bending Stresses in Beams</b>	 <b>292—341</b>
7.1. Introduction	292
7.2. Pure Bending or Simple Bending	292
7.3. Theory of Simple Bending with Assumptions Made	293
7.4. Expression for Bending Stress	294
7.5. Neutral Axis and Moment of Resistance	295
7.6. Bending Stresses in Symmetrical Sections	297
7.7. Section Modulus	300
7.8. Section Modulus for Various Shapes of Beam Sections	300
7.9. Bending Stress in Unsymmetrical Sections	312

<i>Chapter</i>	<i>Pages</i>
7.10. Strength of a Section	... 320
7.11. Composite Beams (Flitched Beams)	... 327
<i>Highlights</i>	... 337
<i>Exercise 7</i>	... 338

**Chapter 8. Shear Stresses in Beams** **342—376**

8.1. Introduction	... 342
8.2. Shear Stress at a Section	... 342
8.3. Shear Stress Distribution for Different Sections	... 348
<i>Highlights</i>	... 373
<i>Exercise 8</i>	... 374

**Chapter 9. Direct and Bending Stresses** **377—408**

9.1. Introduction	... 377
9.2. Combined Bending and Direct Stresses	... 377
9.3. Resultant Stress when a Column of Rectangular Section is Subjected to an Eccentric Load	... 378
9.4. Resultant Stress when a Column of Rectangular Section is Subjected to a Load which is Eccentric to both Axes	... 386
9.5. Resultant Stress for Unsymmetrical Columns with Eccentric Loading	... 393
9.6. Middle Third Rule for Rectangular Sections ( <i>i.e.</i> , Kernel of section)	... 398
9.7. Middle Quarter Rule for Circular Sections ( <i>i.e.</i> , Kernel of section)	... 400
9.8. Kernel of Hollow Circular Section (or value of eccentricity for hollow circular section)	... 401
9.9. Kernel of Hollow Rectangular Section (or value of eccentricity for hollow rectangular section)	... 402
<i>Highlights</i>	... 405
<i>Exercise 9</i>	... 406

**Chapter 10. Dams and Retaining Walls** **409—464**

10.1. Introduction	... 409
10.2. Types of Dams	... 409
10.3. Rectangular Dams	... 409
10.4. Stresses Across the Section of a Rectangular Dam	... 413
10.5. Trapezoidal Dam having Water Face Inclined	... 424
10.6. Stability of a Dam	... 430
10.7. Retaining Walls	... 443
10.8. Rankine's Theory of Earth Pressure	... 445
10.9. Surcharged Retaining Wall	... 455
10.10. Chimneys	... 458
<i>Highlights</i>	... 460
<i>Exercise 10</i>	... 462

*Chapter* *Pages*

**Chapter 11. Analysis of Perfect Frames** **465—510**

11.1. Introduction	... 465
11.2. Types of Frames	... 465
11.3. Assumptions Made in Finding Out the Forces in a Frame	... 466
11.4. Reactions of Supports of a Frame	... 466
11.5. Analysis of a Frame	... 467
11.6. Method of Sections	... 488
11.7. Graphical Method	... 497
<i>Highlights</i>	... 504
<i>Exercise 11</i>	... 504

**Chapter 12. Deflection of Beams** **511—553**

12.1. Introduction	... 511
12.2. Deflection and Slope of a Beam Subjected to Uniform Bending Moment	... 511
12.3. Relation between Slope, Deflection and Radius of Curvature	... 513
12.4. Deflection of a Simply Supported Beam Carrying a Point Load at the Centre	... 515
12.5. Deflection of a Simply Supported Beam with an Eccentric Point Load	... 519
12.6. Deflection of a Simply Supported Beam with a Uniformly Distributed Load	... 526
12.7. Macaulay's Method	... 531
12.8. Moment Area Method	... 546
12.9. Mohr's Theorems	... 548
12.10. Slope and Deflection of a Simply Supported Beam Carrying a Point Load at the Centre by Mohr's Theorem	... 549
12.11. Slope and Deflection of a Simply Supported Beam Carrying a Uniformly Distributed load by Mohr's Theorem	... 550
<i>Highlights</i>	... 551
<i>Exercise 12</i>	... 552

**Chapter 13. Deflection of Cantilevers** **554—577**

13.1. Introduction	... 554
13.2. Deflection of a Cantilever with a Point Load at the Free end by Double Integration Method	... 554
13.3. Deflection of a Cantilever with a Point Load at a Distance ' $\alpha$ ' from the Fixed End	... 556
13.4. Deflection of a Cantilever with a Uniformly Distributed Load	... 557
13.5. Deflection of a Cantilever with a Uniformly Distributed Load for a Distance ' $\alpha$ ' from the Fixed End	... 561
13.6. Deflection of a Cantilever with a Uniformly Distributed Load for a Distance ' $\alpha$ ' from the Free End	... 561
13.7. Deflection of a Cantilever with a Gradually Varying Load	... 567
13.8. Deflection and Slope of a Cantilever by Moment Area Method	... 571
<i>Highlights</i>	... 575
<i>Exercise 13</i>	... 576

Chapter	Pages
<b>Chapter 14. Conjugate Beam Method, Propped Cantilevers and Beams</b>	<b>578—612</b>
14.1. Introduction	578
14.2. Conjugate Beam Method	578
14.3. Deflection and Slope of a Simply Supported Beam with a Point Load at the Centre	578
14.4. Simply Supported Beam Carrying an Eccentric Point Load	580
14.5. Relation between Actual Beam and Conjugate Beam	592
14.6. Deflection and Slope of a Cantilever with a Point Load at the Free End	592
14.7. Propped Cantilevers and Beams	597
14.8. S.F. and B.M. Diagrams for a Propped Cantilever Carrying a Point Load at the Centre and Propped at the Free End	598
14.9. S.F. and B.M. Diagram for a Propped Cantilever Carrying a Uniformly Distributed Load and Propped at the Free End	599
14.10. S.F. and B.M. Diagrams for a Simply Supported Beam with a Uniformly Distributed Load and Propped at the Centre	605
14.11. Yielding of a Prop	609
<i>Highlights</i>	610
<i>Exercise 14</i>	611
<b>Chapter 15. Fixed and Continuous Beams</b>	<b>613—671</b>
15.1. Introduction	613
15.2. Bending Moment Diagram for Fixed Beams	614
15.3. Slope and Deflection for a Fixed Beam Carrying a Point Load at the Centre	618
15.4. Slope and Deflection for a Fixed Beam Carrying an Eccentric Point Load	622
15.5. Slope and Deflection for a Fixed Beam Carrying a Uniformly Distributed Load over the Entire Length	638
15.6. Fixed End Moments of Fixed Beam Due to Sinking of a Support	648
15.7. Advantages of Fixed Beams	651
15.8. Continuous Beams	652
15.9. Bending Moment Diagram for Continuous Beams	652
<i>Highlights</i>	669
<i>Exercise 15</i>	670
<b>Chapter 16. Torsion of Shafts and Springs</b>	<b>672—739</b>
16.1. Introduction	672
16.2. Derivation of Shear Stress Produced in a Circular Shaft Subjected to Torsion	672
16.3. Maximum Torque Transmitted by a Circular Solid Shaft	674
16.4. Torque Transmitted by a Hollow Circular Shafts	676
16.5. Power Transmitted by Shafts	677
16.6. Expression for Torque in Terms of Polar Moment of Inertia	687
16.7. Polar Modulus	688
16.8. Strength of a Shaft and Torsional Rigidity	688

Chapter	Pages
16.9. Flanged Coupling	695
16.10. Strength of a Shaft of Varying Sections	698
16.11. Composite Shaft	706
16.12. Combined Bending and Torsion	710
16.13. Expression for Strain Energy Stored in a Body Due to Torsion	713
16.14. Springs	721
<i>Highlights</i>	734
<i>Exercise 16</i>	736
<b>Chapter 17. Thin Cylinders and Spheres</b>	<b>740—780</b>
17.1. Introduction	740
17.2. Thin Cylindrical Vessel Subjected to Internal Pressure	740
17.3. Stresses in a Thin Cylindrical Vessel Subjected to Internal Pressure	741
17.4. Expression for Circumferential Stress (or hoop stress)	741
17.5. Expression for Longitudinal Stress	742
17.6. Efficiency of a Joint	746
17.7. Effect of Internal Pressure on the Dimensions of a Thin Cylindrical Shell	750
17.8. A Thin Cylindrical Vessel Subjected to Internal Fluid Pressure and a Torque...	761
17.9. Wire Winding of Thin Cylinders	765
17.10. Thin Spherical Shells	770
17.11. Change in Dimensions of a Thin Spherical Shell Due to an Internal Pressure	771
17.12. Rotational Stresses in Thin Cylinders	773
<i>Highlights</i>	776
<i>Exercise 17</i>	777
<b>Chapter 18. Thick Cylinders and Spheres</b>	<b>781—807</b>
18.1. Introduction	781
18.2. Stresses in a Thick Cylindrical Shell	781
18.3. Stresses in Compound Thick Cylinders	789
18.4. Initial Difference in Radii at the Junction of a Compound Cylinder for Shrinkage	794
18.5. Thick Spherical Shells	800
<i>Highlights</i>	805
<i>Exercise 18</i>	806
<b>Chapter 19. Columns and Struts</b>	<b>808—870</b>
19.1. Introduction	808
19.2. Failure of a Column	808
19.3. Assumptions Made in the Euler's Column Theory	809
19.4. End Conditions for Long Columns	809
19.5. Expression for Crippling Load When Both the Ends of the Column are Hinged	810
19.6. Expression for Crippling Load When One End of the Column is Fixed and the Other End is Free	811

Chapter	Pages
19.7. Expression for Crippling Load When Both the Ends of the Column are Fixed ...	818
19.8. Expression for Crippling Load When One End of the Column is Fixed and the Other End is Hinged (or Pinned) ...	816
19.9. Effective Length (or equivalent length) of a Column ...	818
19.10. Limitation of Euler's Formula ...	820
19.11. Rankine's Formula ...	835
19.12. Straight Line Formula ...	847
19.13. Johnson's Parabolic Formula ...	847
19.14. Factor of Safety ...	848
19.15. Formula by Indian Standard Code (I.S. Code) for Mild Steel ...	848
19.16. Columns with Eccentric Load ...	849
19.17. Columns with Initial Curvature ...	853
19.18. Strut with Lateral Load (or beam columns) ...	858
<i>Highlights</i> ...	866
<i>Exercise 19</i> ...	868

**Chapter 20. Riveted Joints** **871—899**

20.1. Introduction ...	871
20.2. Types of Riveted Joints ...	871
20.3. Chain Riveted Joint ...	872
20.4. Zig-zag Riveted Joint ...	872
20.5. Diamond Riveted Joint ...	872
20.6. Failure of a Riveted Joint ...	876
20.7. Strength of a Riveted Joint ...	879
20.8. Efficiency of a Riveted Joint ...	880
20.9. Design of a Riveted Joint ...	892
<i>Highlights</i> ...	895
<i>Exercise 20</i> ...	897

**Chapter 21. Welded Joints** **900—918**

21.1. Introduction ...	900
21.2. Advantages and Disadvantages of Welded Connections ...	900
21.3. Types of Welded Joints ...	901
21.4. Analysis of a Compound Weld ...	905
21.5. Analysis of Unsymmetrical Welded Sections which are Loaded Axially ...	907
<i>Highlights</i> ...	914
<i>Exercise 21</i> ...	916

**Chapter 22. Rotating Discs and Cylinders** **919—956**

22.1. Introduction ...	919
22.2. Expression for Stresses in a Rotating Thin Disc ...	919
22.3. Disc of Uniform Strength ...	936

Chapter	Pages
22.4. Long Cylinders ...	940
<i>Highlights</i> ...	953
<i>Exercise 22</i> ...	955

**Chapter 23. Bending of Curved Bars** **957—1004**

23.1. Introduction ...	957
23.2. Assumptions Made in the Derivation of Stresses in a Curved Bar ...	957
23.3. Expression for Stresses in a Curved Bar ...	957
23.4. Determination of Factor ' $h^2$ ' for Various Sections ...	964
23.5. Resultant Stress in a Curved Bar Subjected to Direct Stresses and Bending Stresses ...	977
23.6. Resultant Stress in a Hook ...	978
23.7. Stresses in Circular Ring ...	987
23.8. Stresses in a Chain Link ...	993
<i>Highlights</i> ...	1000
<i>Exercise 23</i> ...	1002

**Chapter 24. Theories of Failure** **1005—1037**

24.1. Introduction ...	1005
24.2. Maximum Principal Stress Theory ...	1005
24.3. Maximum Principal Strain Theory ...	1006
24.4. Maximum Shear Stress Theory ...	1010
24.5. Maximum Strain Energy Theory ...	1014
24.6. Maximum Shear Strain Energy Theory ...	1018
24.7. Graphical Representation of Theories for Two Dimensional Stress System ...	1020
24.8. Important Points from Theories of Failures used in Design ...	1024
24.9. Energy of Distortion (or shear strain energy) ...	1033
<i>Highlights</i> ...	1036
<i>Exercise 24</i> ...	1036

**Chapter 25. Objective Type Questions** **1038—1088**

25.1. Objective Type Questions Generally Asked in Competitive Examinations ...	1038
25.2. Answer of Objective Type Questions ...	1065
25.3. Objective Type Questions from Competitive Examinations ...	1066
25.4. Answers with Explanations ...	1074

**Subject Index** **1089—1092**



## PREFACE TO THE FIRST EDITION

I am glad to present the book entitled, 'A Textbook of Strength of Materials' to the engineering students of mechanical, civil, electrical, aeronautical and chemical and also to the students of A.M.I.E. Examination of Institution of Engineers (India). The course-contents have been planned in such a way that the general requirements of all engineering students are fulfilled.

During my long experience of teaching to the engineering students for the past 20 years, I have observed that the students face difficulty in understanding clearly the basic principles, fundamental concepts and theory without adequate solved problems along with the text. To meet this very basic requirement to the students, a large number of the questions taken from the examinations of the various Universities of India and from other professional and competitive examinations (such as Institution of Engineers and U.P.S.C. Engineering Service Examinations) have been solved along with the text in S.I. units.

The book is written in a simple and easy-to-follow language, so that even an average student can grasp the subject by self-study. At the end of each chapter highlights, theoretical questions and many unsolved numerical problems with answer are given for the students to solve them.

I am thankful to my colleagues, friends and students who encouraged me to write this book. I am grateful to Institution of Engineers (India), various Universities of India and those authorities whose work have been consulted and gave me a great help in preparing the book.

I express my appreciation and gratefulness to my publisher, Shri R.K. Gupta (a Mechanical Engineer) for his most co-operative, painstaking attitude and untiring efforts for bringing out the book in a short period.

Mrs. Nirmal Bansal deserves special credit as she not only provided an ideal atmosphere at home for book writing but also gave inspiration and valuable suggestions.

Though every care has been taken in checking the manuscripts and proof reading, yet claiming perfection is very difficult. I shall be very grateful to the readers and users of this book for pointing any mistakes that might have crept in. Suggestions for improvement are most welcome and would be incorporated in the next edition with a view to make the book more useful.

—AUTHOR

## PREFACE TO THE FOURTH EDITION

The popularity of the third edition and reprints of the textbook of Strength of Materials amongst the students and the teachers of the various Universities of the country, has prompted the bringing out of the fourth edition of the book so soon. The fourth edition has been thoroughly revised and brought up-to-date. A large number of problems from different B.E. degree examinations upto 2005 of Indian Universities and other examining bodies, such as Institution of Engineers U.P.S.C. (Engineering Services) and Gate have been selected and have been solved at proper places in this edition in S.I. Units.

Three advanced topics of Strength of Materials such as stresses due to rotation in thin and thick cylinders, bending of curved bars and theories of failure of the material have been added. These chapters have been written in such a simple and easy-to-follow language that even an average student can understand easily by self-study.

In the chapter of 'Columns and Struts', the advanced articles such as columns with eccentric load, with initial curvature and beam columns have been included.

The notations in this edition have been used upto-date by the use of sigma and tau for stresses.

The *objective type multiple-choice questions* are often asked in the various competitive examinations. Hence a large number of objective type questions with answers have been added in the end of the book.

Also a large number of objective type questions which have been asked in most of competitive examinations such as Engineering Services Examination and Gate with answers and explanation have been incorporated in this edition.

With these editions, it is hoped that the book will be quite useful for the students of different branches of Engineering at various Engineering Institutions.

I express my sincere thanks to my colleagues, friends, students and the teachers of different Indian Universities for their valuable suggestions and recommending the book to their students.

Suggestions for the improvement of this book are most welcome and would be incorporated in the next edition with a view to make the book more useful.

—AUTHOR

## Simple Stresses and Strains

### 1.1. INTRODUCTION

When an external force acts on a body, the body tends to undergo some deformation. Due to cohesion between the molecules, the body resists deformation. This resistance by which material of the body opposes the deformation is known as **strength of material**. Within a certain limit (*i.e.*, in the elastic stage) the resistance offered by the material is proportional to the deformation brought out on the material by the external force. Also within this limit the resistance is equal to the external force (or applied load). But beyond the elastic stage, the resistance offered by the material is less than the applied load. In such a case, the deformation continues, until failure takes place.

Within elastic stage, the resisting force equals applied load. This resisting force per unit area is called stress or intensity of stress.

### 1.2. STRESS

The force of resistance per unit area, offered by a body against deformation is known as stress. The external force acting on the body is called the *load or force*. The load is applied on the body while the stress is induced in the material of the body. A loaded member remains in equilibrium when the resistance offered by the member against the deformation and the applied load are equal.

Mathematically stress is written as,  $\sigma = \frac{P}{A}$

where  $\sigma = \text{Stress}$  (also called intensity of stress),

$P = \text{External force or load, and}$

$A = \text{Cross-sectional area.}$

**1.2.1. Units of Stress.** The unit of stress depends upon the unit of load (or force) and unit of area. In M.K.S. units, the force is expressed in kgf and area in metre square (*i.e.*,  $\text{m}^2$ ). Hence unit of stress becomes as  $\text{kgf}/\text{m}^2$ . If area is expressed in centimetre square (*i.e.*,  $\text{cm}^2$ ), the stress is expressed as  $\text{kgf}/\text{cm}^2$ .

In the S.I. units, the force is expressed in newtons (written as N) and area is expressed as  $\text{m}^2$ . Hence unit of stress becomes as  $\text{N}/\text{m}^2$ . The area is also expressed in millimetre square then unit of force becomes as  $\text{N}/\text{mm}^2$ .

$$1 \text{ N}/\text{m}^2 = 1 \text{ N}/(100 \text{ cm})^2 = 1 \text{ N}/10^4 \text{ cm}^2$$

$$= 10^{-4} \text{ N}/\text{cm}^2 \text{ or } 10^{-6} \text{ N}/\text{mm}^2$$

$$\left( \because \frac{1}{\text{cm}^2} = \frac{1}{10^2 \text{ mm}^2} \right)$$

$$\therefore 1 \text{ N/mm}^2 = 10^6 \text{ N/m}^2.$$

$$\text{Also } 1 \text{ N/m}^2 = 1 \text{ Pascal} = 1 \text{ Pa}.$$

The large quantities are represented by kilo, mega, giga and terra. They stand for :

Kilo =  $10^3$  and represented by ..... k

Mega =  $10^6$  and represented by ..... M

Giga =  $10^9$  and represented by ..... G

Terra =  $10^{12}$  and represented by ..... T.

Thus mega newton means  $10^6$  newtons and is represented by MN. The symbol 1 MPa stands for 1 mega pascal which is equal to  $10^6$  pascal (or  $10^6 \text{ N/m}^2$ ).

The small quantities are represented by milli, micro, nana and pica. They are equal to

Milli =  $10^{-3}$  and represented by ..... m

Micro =  $10^{-6}$  and represented by .....  $\mu$

Nana =  $10^{-9}$  and represented by .....  $\eta$

Pica =  $10^{-12}$  and represented by ..... p.

Notes. 1. Newton is a force acting on a mass of one kg and produces an acceleration of  $1 \text{ m/s}^2$  i.e.,  $1 \text{ N} = 1 (\text{kg}) \times 1 \text{ m/s}^2$ .

2. The stress in S.I. units is expressed in  $\text{N/m}^2$  or  $\text{N/mm}^2$ .

3. The stress  $1 \text{ N/mm}^2 = 10^6 \text{ N/m}^2 = \text{MN/m}^2$ . Thus one  $\text{N/mm}^2$  is equal to one  $\text{MN/m}^2$ .

4. One pascal is written as 1 Pa and is equal to  $1 \text{ N/m}^2$ .

### 1.3. STRAIN

When a body is subjected to some external force, there is some change of dimension of the body. The ratio of change of dimension of the body to the original dimension is known as strain. Strain is dimensionless.

Strain may be :

1. Tensile strain,
2. Compressive strain,
3. Volumetric strain, and
4. Shear strain.

If there is some increase in length of a body due to external force, then the ratio of increase of length to the original length of the body is known as *tensile strain*. But if there is some decrease in length of the body, then the ratio of decrease of the length of the body to the original length is known as *compressive strain*. The ratio of change of volume of the body to the original volume is known as *volumetric strain*. The strain produced by shear stress is known as shear strain.

### 1.4. TYPES OF STRESSES

The stress may be normal stress or a shear stress.

Normal stress is the stress which acts in a direction perpendicular to the area. It is represented by  $\sigma$  (sigma). The normal stress is further divided into tensile stress and compressive stress.

**1.4.1. Tensile Stress.** The stress induced in a body, when subjected to two equal and opposite pulls as shown in Fig. 1.1 (a) as a result of which there is an increase in length, is known as tensile stress. The ratio of increase in length to the original length is known as *tensile strain*. The tensile stress acts normal to the area and it pulls on the area.

- Let  $P$  = Pull (or force) acting on the body,  
 $A$  = Cross-sectional area of the body,  
 $L$  = Original length of the body,  
 $dL$  = Increase in length due to pull  $P$  acting on the body,  
 $\sigma$  = Stress induced in the body, and  
 $e$  = Strain (i.e., tensile strain).

Fig. 1.1 (a) shows a bar subjected to a tensile force  $P$  at its ends. Consider a section  $x-x$ , which divides the bar into two parts. The part left to the section  $x-x$ , will be in equilibrium if  $P$  = Resisting force ( $R$ ). This is shown in Fig. 1.1 (b). Similarly the part right to the section  $x-x$ , will be in equilibrium if  $P$  = Resisting force as shown in Fig. 1.1 (c). This resisting force per unit area is known as stress or intensity of stress.

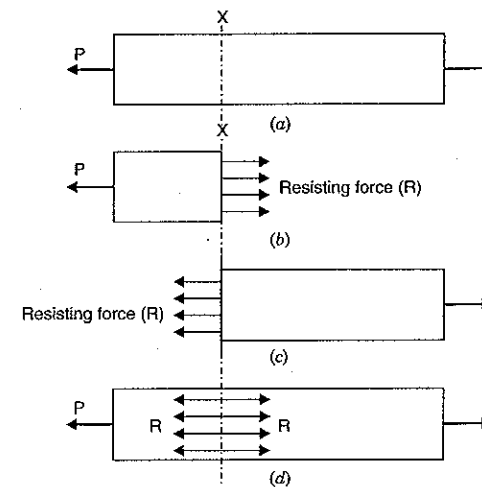

Fig. 1.1

$$\therefore \text{Tensile stress} = \sigma = \frac{\text{Resisting force (R)}}{\text{Cross-sectional area}} = \frac{\text{Tensile load (P)}}{A} \quad (\because P = R)$$

$$\text{or } \sigma = \frac{P}{A} \quad \dots(1.1)$$

And tensile strain is given by,

$$e = \frac{\text{Increase in length}}{\text{Original length}} = \frac{dL}{L} \quad \dots(1.2)$$

**1.4.2. Compressive Stress.** The stress induced in a body, when subjected to two equal and opposite pushes as shown in Fig. 1.2 (a) as a result of which there is a decrease in length of the body, is known as compressive stress. And the ratio of decrease in length to the original length is known as *compressive strain*. The compressive stress acts normal to the area and it pushes on the area.

Let an axial push  $P$  is acting on a body is cross-sectional area  $A$ . Due to external push  $P$ , let the original length  $L$  of the body decreases by  $dL$ .

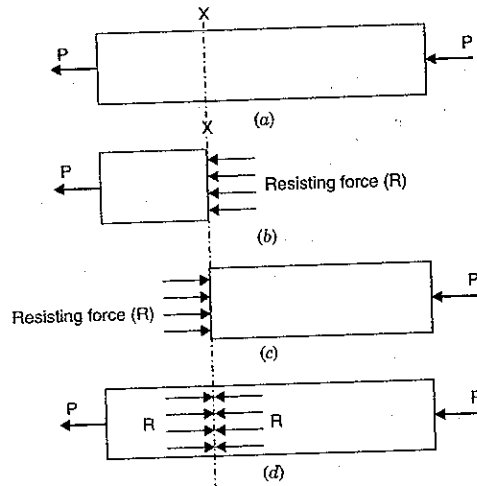

Fig. 1.2

Then compressive stress is given by,

$$\sigma = \frac{\text{Resisting Force (R)}}{\text{Area (A)}} = \frac{\text{Push (P)}}{\text{Area (A)}} = \frac{P}{A}$$

And compressive strain is given by,

$$e = \frac{\text{Decrease in length}}{\text{Original length}} = \frac{dL}{L}$$

**1.4.3. Shear Stress.** The stress induced in a body, when subjected to two equal and opposite forces which are acting tangentially across the resisting section as shown in Fig. 1.3 as a result of which the body tends to shear off across the section, is known as shear stress. The corresponding strain is known as shear strain. The shear stress is the stress which acts tangential to the area. It is represented by  $\tau$ .

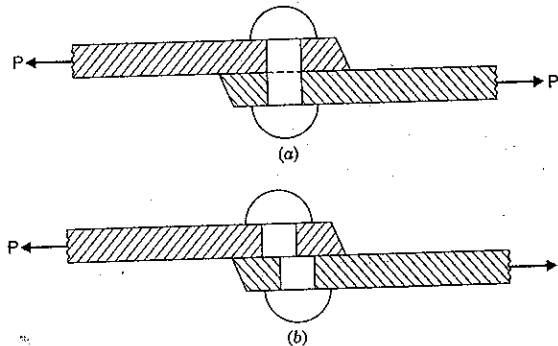

Fig. 1.3

Consider a rectangular block of height  $h$ , length  $L$  and width unity. Let the bottom face  $AB$  of the block be fixed to the surface as shown in Fig. 1.4 (a). Let a force  $P$  be applied tangentially along the top face  $CD$  of the block. Such a force acting tangentially along a surface is known as shear force. For the equilibrium of the block, the surface  $AB$  will offer a tangential reaction  $P$  equal and opposite to the applied tangential force  $P$ .

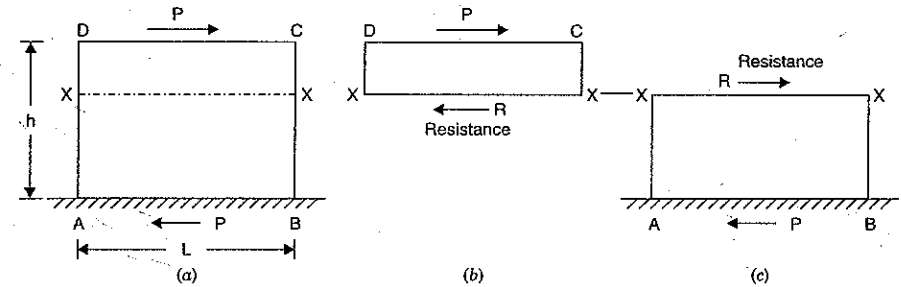

Fig. 1.4

Consider a section  $x-x$  (parallel to the applied force), which divides the block into two parts. The upper part will be in equilibrium if  $P = \text{Resistance (R)}$ . This is shown in Fig. 1.4 (b). Similarly the lower part will be in equilibrium if  $P = \text{Resistance (R)}$  as shown in Fig. 1.4 (c). This resistance is known as shear resistance. And the shear resistance per unit area is known as shear stress which is represented by  $\tau$ .

$$\begin{aligned} \text{Shear stress, } \tau &= \frac{\text{Shear resistance}}{\text{Shear area}} = \frac{R}{A} \\ &= \frac{P}{L \times 1} \end{aligned}$$

$$(\because R = P \text{ and } A = L \times 1) \dots(1.3)$$

Note that shear stress is tangential to the area over which it acts.

As the bottom face of the block is fixed, the face  $ABCD$  will be distorted to  $ABC_1D_1$  through an angle  $\phi$  as a result of force  $P$  as shown in Fig. 1.4 (d).

And shear strain ( $\phi$ ) is given by,

$$\phi = \frac{\text{Transversal displacement}}{\text{Distance AD}}$$

or

$$\phi = \frac{DD_1}{AD} = \frac{dl}{h}$$

$$\dots(1.4)$$

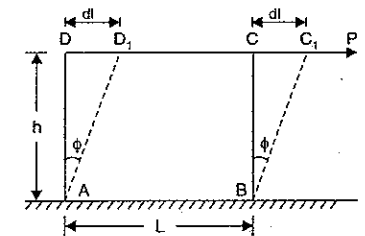

Fig. 1.4 (d)

**1.5. ELASTICITY AND ELASTIC LIMIT**

When an external force acts on a body, the body tends to undergo some deformation. If the external force is removed and the body comes back to its origin shape and size (which means the deformation disappears completely), the body is known as *elastic body*. This property,

by virtue of which certain materials return back to their original position after the removal of the external force, is called *elasticity*.

The body will regain its previous shape and size only when the deformation caused by the external force, is within a certain limit. Thus there is a limiting value of force up to and within which, the deformation completely disappears on the removal of the force. The value of stress corresponding to this limiting force is known as the *elastic limit* of the material.

If the external force is so large that the stress exceeds the elastic limit, the material loses to some extent its property of elasticity. If now the force is removed, the material will not return to its origin shape and size and there will be a residual deformation in the material.

## 1.6. HOOKE'S LAW AND ELASTIC MODULI

Hooke's Law states that when a material is loaded within elastic limit, the stress is proportional to the strain produced by the stress. This means the ratio of the stress to the corresponding strain is a constant within the elastic limit. This constant is known as Modulus of Elasticity or Modulus of Rigidity or Elastic Moduli.

## 1.7. MODULUS OF ELASTICITY (OR YOUNG'S MODULUS)

The ratio of tensile stress or compressive stress to the corresponding strain is a constant. This ratio is known as Young's Modulus or Modulus of Elasticity and is denoted by  $E$ .

$$E = \frac{\text{Tensile stress}}{\text{Tensile strain}} \quad \text{or} \quad \frac{\text{Compressive stress}}{\text{Compressive strain}}$$

$$E = \frac{\sigma}{e} \quad \dots(1.5)$$

**1.7.1. Modulus of Rigidity or Shear Modulus.** The ratio of shear stress to the corresponding shear strain within the elastic limit, is known as Modulus of Rigidity or Shear Modulus. This is denoted by  $C$  or  $G$  or  $N$ .

$$C \text{ (or } G \text{ or } N) = \frac{\text{Shear stress}}{\text{Shear strain}} = \frac{\tau}{\phi} \quad \dots(1.6)$$

Let us define factor of safety also.

## 1.8. FACTOR OF SAFETY

It is defined as the ratio of ultimate tensile stress to the working (or permissible) stress. Mathematically it is written as

$$\text{Factor of safety} = \frac{\text{Ultimate stress}}{\text{Permissible stress}} \quad \dots(1.7)$$

## 1.9. CONSTITUTIVE RELATIONSHIP BETWEEN STRESS AND STRAIN

**1.9.1. For One-Dimensional Stress System.** The relationship between stress and strain for a unidirectional stress (*i.e.*, for normal stress in one direction only) is given by **Hooke's law**, which states that when a material is loaded within its elastic limit, the normal stress developed is proportional to the strain produced. This means that the ratio of the normal

stress to the corresponding strain is a constant within the elastic limit. This constant is represented by  $E$  and is known as modulus of elasticity or Young's modulus of elasticity.

$$\frac{\text{Normal stress}}{\text{Corresponding strain}} = \text{Constant} \quad \text{or} \quad \frac{\sigma}{e} = E$$

where  $\sigma$  = Normal stress,  $e$  = Strain and  $E$  = Young's modulus

$$\text{or} \quad e = \frac{\sigma}{E} \quad \dots[1.7 (A)]$$

The above equation gives the stress and strain relation for the normal stress in one direction.

**1.9.2. For Two-Dimensional Stress System.** Before knowing the relationship between stress and strain for two-dimensional stress system, we shall have to define longitudinal strain, lateral strain, and Poisson's ratio.

**1. Longitudinal strain.** When a body is subjected to an axial tensile load, there is an increase in the length of the body. But at the same time there is a decrease in other dimensions of the body at right angles to the line of action of the applied load. Thus the body is having axial deformation and also deformation at right angles to the line of action of the applied load (*i.e.*, lateral deformation).

The ratio of axial deformation to the original length of the body is known as longitudinal (or linear) strain. The longitudinal strain is also defined as the deformation of the body per unit length in the direction of the applied load.

Let  $L$  = Length of the body,  
 $P$  = Tensile force acting on the body,  
 $\delta L$  = Increase in the length of the body in the direction of  $P$ .

$$\text{Then, longitudinal strain} = \frac{\delta L}{L}$$

**2. Lateral strain.** The strain at right angles to the direction of applied load is known as lateral strain. Let a rectangular bar of length  $L$ , breadth  $b$  and depth  $d$  is subjected to an axial tensile load  $P$  as shown in Fig. 1.5. The length of the bar will increase while the breadth and depth will decrease.

Let  $\delta L$  = Increase in length,  
 $\delta b$  = Decrease in breadth, and  
 $\delta d$  = Decrease in depth.

$$\text{Then longitudinal strain} = \frac{\delta L}{L} \quad \dots[1.7 (B)]$$

$$\text{and lateral strain} = \frac{\delta b}{b} \quad \text{or} \quad \frac{\delta d}{d} \quad \dots[1.7 (C)]$$

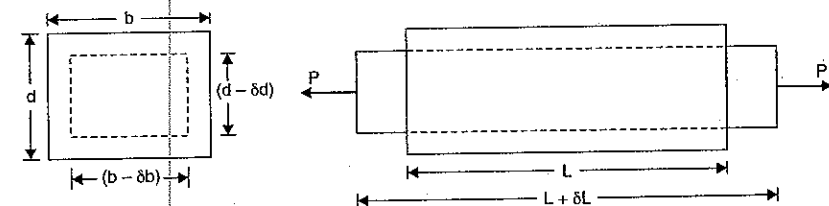

Fig. 1.5

**Note.** (i) If longitudinal strain is tensile, the lateral strains will be compressive.

(ii) If longitudinal strain is compressive then lateral strains will be tensile.

(iii) Hence every longitudinal strain in the direction of load is accompanied by lateral strains of the opposite kind in all directions perpendicular to the load.

**3. Poisson's ratio.** The ratio of lateral strain to the longitudinal strain is a constant for a given material, when the material is stressed within the elastic limit. This ratio is called **Poisson's ratio** and it is generally denoted by  $\mu$ . Hence mathematically,

$$\text{Poisson's ratio, } \mu = \frac{\text{Lateral strain}}{\text{Longitudinal strain}} \quad \dots[1.7 (D)]$$

or Lateral strain =  $\mu \times$  Longitudinal strain

As lateral strain is opposite in sign to longitudinal strain, hence algebraically, lateral strain is written as

$$\text{Lateral strain} = -\mu \times \text{Longitudinal strain} \quad \dots[1.7 (E)]$$

**4. Relationship between stress and strain.** Consider a two-dimensional figure  $ABCD$ , subjected to two mutually perpendicular stresses  $\sigma_1$  and  $\sigma_2$ .

Refer to Fig. 1.5 (a).

Let  $\sigma_1$  = Normal stress in  $x$ -direction

$\sigma_2$  = Normal stress in  $y$ -direction

Consider the strain produced by  $\sigma_1$ .

The stress  $\sigma_1$  will produce strain in the direction of  $x$  and also in the direction of  $y$ . The strain in the direction of  $x$  will be

longitudinal strain and will be equal to  $\frac{\sigma_1}{E}$  whereas the strain in

the direction of  $y$  will be lateral strain and will be equal to  $-\mu \times \frac{\sigma_1}{E}$ . ( $\because$  Lateral strain =  $-\mu \times$  longitudinal strain)

Now consider the strain produced by  $\sigma_2$ .

The stress  $\sigma_2$  will produce strain in the direction of  $y$  and also in the direction of  $x$ . The strain in the direction of  $y$  will be longitudinal strain and will be equal to  $\frac{\sigma_2}{E}$  whereas the

strain in the direction of  $x$  will be lateral strain and will be equal to  $-\mu \times \frac{\sigma_2}{E}$ .

Let  $e_1$  = Total strain in  $x$ -direction  
 $e_2$  = Total strain in  $y$ -direction

Now total strain in the direction of  $x$  due to stresses  $\sigma_1$  and  $\sigma_2$  =  $\frac{\sigma_1}{E} - \mu \frac{\sigma_2}{E}$

Similarly total strain in the direction of  $y$  due to stresses  $\sigma_1$  and  $\sigma_2$  =  $\frac{\sigma_2}{E} - \mu \frac{\sigma_1}{E}$

$$\therefore e_1 = \frac{\sigma_1}{E} - \mu \frac{\sigma_2}{E} \quad \dots[1.7 (F)]$$

$$e_2 = \frac{\sigma_2}{E} - \mu \frac{\sigma_1}{E} \quad \dots[1.7 (G)]$$

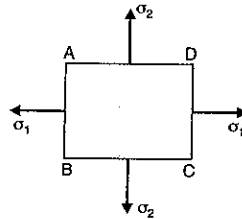

Fig. 1.5 (a)

The above two equations gives the stress and strain relationship for the two-dimensional stress system. In the above equations, tensile stress is taken to be positive whereas the compressive stress negative.

**1.9.3. For Three-Dimensional Stress System.** Fig. 1.5 (b) shows a three-dimensional body subjected to three orthogonal normal stresses  $\sigma_1, \sigma_2, \sigma_3$  acting in the directions of  $x, y$  and  $z$  respectively.

Consider the strains produced by each stress separately.

The stress  $\sigma_1$  will produce strain in the direction of  $x$  and also in the directions of  $y$  and  $z$ . The strain in the direction of  $x$  will be  $\frac{\sigma_1}{E}$  whereas the strains in the direction of  $y$  and  $z$  will be  $-\mu \frac{\sigma_1}{E}$ .

Similarly the stress  $\sigma_2$  will produce strain  $\frac{\sigma_2}{E}$  in the direction of  $y$  and strain of  $-\mu \frac{\sigma_2}{E}$  in the direction of  $x$  and  $z$  each.

Also the stress  $\sigma_3$  will produce strain  $\frac{\sigma_3}{E}$  in the direction of  $z$  and strain of  $-\mu \times \frac{\sigma_3}{E}$  in the direction of  $x$  and  $y$ .

Total strain in the direction of  $x$  due to stresses  $\sigma_1, \sigma_2$  and  $\sigma_3$  =  $\frac{\sigma_1}{E} - \mu \frac{\sigma_2}{E} - \mu \frac{\sigma_3}{E}$ .

Similarly total strains in the direction of  $y$  due to stresses  $\sigma_1, \sigma_2$  and  $\sigma_3$

$$= \frac{\sigma_2}{E} - \mu \frac{\sigma_3}{E} - \mu \frac{\sigma_1}{E}$$

and total strains in the direction of  $z$  due to stresses  $\sigma_1, \sigma_2$  and  $\sigma_3$

$$= \frac{\sigma_3}{E} - \mu \frac{\sigma_1}{E} - \mu \frac{\sigma_2}{E}$$

Let  $e_1, e_2$  and  $e_3$  are total strains in the direction of  $x, y$  and  $z$  respectively. Then

$$e_1 = \frac{\sigma_1}{E} - \mu \frac{\sigma_2}{E} - \mu \frac{\sigma_3}{E} \quad \dots[1.7 (H)]$$

$$e_2 = \frac{\sigma_2}{E} - \mu \frac{\sigma_3}{E} - \mu \frac{\sigma_1}{E} \quad \dots[1.7 (I)]$$

and

$$e_3 = \frac{\sigma_3}{E} - \mu \frac{\sigma_1}{E} - \mu \frac{\sigma_2}{E} \quad \dots[1.7 (J)]$$

The above three equations give the stress and strain relationship for the three orthogonal normal stress system.

**Problem 1.1.** A rod 150 cm long and of diameter 2.0 cm is subjected to an axial pull of 20 kN. If the modulus of elasticity of the material of the rod is  $2 \times 10^5$  N/mm<sup>2</sup>; determine:

- the stress,
- the strain, and
- the elongation of the rod.

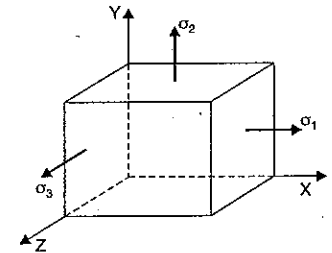

Fig. 1.5 (b)

**Sol. Given :** Length of the rod,  $L = 150$  cm  
 Diameter of the rod,  $D = 2.0$  cm = 20 mm  
 $\therefore$  Area,  $A = \frac{\pi}{4} (20)^2 = 100\pi$  mm<sup>2</sup>  
 Axial pull,  $P = 20$  kN = 20,000 N  
 Modulus of elasticity,  $E = 2.0 \times 10^5$  N/mm<sup>2</sup>

(i) The stress ( $\sigma$ ) is given by equation (1.1) as

$$\sigma = \frac{P}{A} = \frac{20000}{100\pi} = 63.662 \text{ N/mm}^2. \text{ Ans.}$$

(ii) Using equation (1.5), the strain is obtained as

$$E = \frac{\sigma}{e}$$

$$\therefore \text{ Strain, } e = \frac{\sigma}{E} = \frac{63.662}{2 \times 10^5} = 0.000318. \text{ Ans.}$$

(iii) Elongation is obtained by using equation (1.2) as

$$e = \frac{dL}{L}$$

$$\therefore \text{ Elongation, } dL = e \times L \\ = 0.000318 \times 150 = 0.0477 \text{ cm. Ans.}$$

**Problem 1.2.** Find the minimum diameter of a steel wire, which is used to raise a load of 4000 N if the stress in the rod is not to exceed 95 MN/m<sup>2</sup>.

**Sol. Given :** Load,  $P = 4000$  N  
 Stress,  $\sigma = 95$  MN/m<sup>2</sup> = 95  $\times 10^6$  N/m<sup>2</sup> ( $\because$  M = Mega = 10<sup>6</sup>)  
 $= 95$  N/mm<sup>2</sup> ( $\because 10^6$  N/m<sup>2</sup> = 1 N/mm<sup>2</sup>)

Let  $D =$  Diameter of wire in mm

$$\therefore \text{ Area, } A = \frac{\pi}{4} D^2$$

$$\text{Now stress} = \frac{\text{Load}}{\text{Area}} = \frac{P}{A} \\ 95 = \frac{4000}{\frac{\pi}{4} D^2} = \frac{4000 \times 4}{\pi D^2} \text{ or } D^2 = \frac{4000 \times 4}{\pi \times 95} = 53.61$$

$$\therefore D = 7.32 \text{ mm. Ans.}$$

**Problem 1.3.** Find the Young's Modulus of a brass rod of diameter 25 mm and of length 250 mm which is subjected to a tensile load of 50 kN when the extension of the rod is equal to 0.3 mm.

**Sol. Given :** Dia. of rod,  $D = 25$  mm

$$\therefore \text{ Area of rod, } A = \frac{\pi}{4} (25)^2 = 490.87 \text{ mm}^2$$

$$\text{Tensile load, } P = 50 \text{ kN} = 50 \times 1000 = 50,000 \text{ N}$$

$$\text{Extension of rod, } dL = 0.3 \text{ mm}$$

$$\text{Length of rod, } L = 250 \text{ mm}$$

Stress ( $\sigma$ ) is given by equation (1.1), as

$$\sigma = \frac{P}{A} = \frac{50,000}{490.87} = 101.86 \text{ N/mm}^2.$$

Strain ( $e$ ) is given by equation (1.2), as

$$e = \frac{dL}{L} = \frac{0.3}{250} = 0.0012.$$

Using equation (1.5), the Young's Modulus ( $E$ ) is obtained, as

$$E = \frac{\text{Stress}}{\text{Strain}} = \frac{101.86 \text{ N/mm}^2}{0.0012} = 84883.33 \text{ N/mm}^2 \\ = 84883.33 \times 10^6 \text{ N/m}^2. \text{ Ans. } (\because 1 \text{ N/mm}^2 = 10^6 \text{ N/m}^2) \\ = 84.883 \times 10^9 \text{ N/m}^2 = 84.883 \text{ GN/m}^2. \text{ Ans. } (\because 10^9 = \text{G})$$

**Problem 1.4.** A tensile test was conducted on a mild steel bar. The following data was obtained from the test :

- |  |            |
|--|------------|
| (i) Diameter of the steel bar            | = 3 cm     |
| (ii) Gauge length of the bar             | = 20 cm    |
| (iii) Load at elastic limit              | = 250 kN   |
| (iv) Extension at a load of 150 kN       | = 0.21 mm  |
| (v) Maximum load                         | = 380 kN   |
| (vi) Total extension                     | = 60 mm    |
| (vii) Diameter of the rod at the failure | = 2.25 cm. |

Determine : (a) the Young's modulus, (b) the stress at elastic limit,  
 (c) the percentage elongation, and (d) the percentage decrease in area.

$$\text{Sol. Area of the rod, } A = \frac{\pi}{4} D^2 = \frac{\pi}{4} (3)^2 \text{ cm}^2 \\ = 7.0685 \text{ cm}^2 = 7.0685 \times 10^{-4} \text{ m}^2. \quad \left[ \because \text{cm}^2 = \left(\frac{1}{100}\right)^2 \text{m}^2 \right]$$

(a) To find Young's modulus, first calculate the value of stress and strain within elastic limit. The load at elastic limit is given but the extension corresponding to the load at elastic limit is not given. But a load of 150 kN (which is within elastic limit) and corresponding extension of 0.21 mm are given. Hence these values are used for stress and strain within elastic limit

$$\therefore \text{ Stress} = \frac{\text{Load}}{\text{Area}} = \frac{150 \times 1000}{7.0685 \times 10^{-4}} \text{ N/m}^2 \quad (\because 1 \text{ kN} = 1000 \text{ N})$$

$$= 21220.9 \times 10^4 \text{ N/m}^2$$

$$\text{and Strain} = \frac{\text{Increase in length (or Extension)}}{\text{Original length (or Gauge length)}}$$

$$= \frac{0.21 \text{ mm}}{20 \times 10 \text{ mm}} = 0.00105$$

$\therefore$  Young's Modulus,

$$E = \frac{\text{Stress}}{\text{Strain}} = \frac{21220.9 \times 10^4}{0.00105} = 20209523 \times 10^4 \text{ N/m}^2$$

$$= 202.095 \times 10^9 \text{ N/m}^2$$

$$= 202.095 \text{ GN/m}^2. \text{ Ans.}$$

(b) The stress at the elastic limit is given by,

$$\text{Stress} = \frac{\text{Load at elastic limit}}{\text{Area}} = \frac{250 \times 1000}{7.0685 \times 10^{-4}}$$

$$= 35368 \times 10^4 \text{ N/m}^2$$

$$= 353.68 \times 10^6 \text{ N/m}^2$$

$$= 353.68 \text{ MN/m}^2. \text{ Ans.}$$

$$(\because 10^9 = \text{Giga} = \text{G})$$

$$(\because 10^6 = \text{Mega} = \text{M})$$

(c) The percentage elongation is obtained as,

Percentage elongation

$$= \frac{\text{Total increase in length}}{\text{Original length (or Gauge length)}} \times 100$$

$$= \frac{60 \text{ mm}}{20 \times 10 \text{ mm}} \times 100 = 30\%. \text{ Ans.}$$

(d) The percentage decrease in area is obtained as,

Percentage decrease in area

$$= \frac{(\text{Original area} - \text{Area at the failure})}{\text{Original area}} \times 100$$

$$= \frac{\left(\frac{\pi}{4} \times 3^2 - \frac{\pi}{4} \times 2.25^2\right)}{\frac{\pi}{4} \times 3^2} \times 100$$

$$= \left(\frac{3^2 - 2.25^2}{3^2}\right) \times 100 = \frac{(9 - 5.0625)}{9} \times 100 = 43.75\%. \text{ Ans.}$$

**Problem 1.5.** The safe stress, for a hollow steel column which carries an axial load of  $2.1 \times 10^3 \text{ kN}$  is  $125 \text{ MN/m}^2$ . If the external diameter of the column is  $30 \text{ cm}$ , determine the internal diameter.

Sol. Given :

Safe stress\*,  $\sigma = 125 \text{ MN/m}^2 = 125 \times 10^6 \text{ N/m}^2$

Axial load,  $P = 2.1 \times 10^3 \text{ kN} = 2.1 \times 10^6 \text{ N}$

External diameter,  $D = 30 \text{ cm} = 0.30 \text{ m}$

Let  $d = \text{Internal diameter}$

$\therefore$  Area of cross-section of the column,

$$A = \frac{\pi}{4} (D^2 - d^2) = \frac{\pi}{4} (30^2 - d^2) \text{ m}^2$$

Using equation (1.1),  $\sigma = \frac{P}{A}$

\*Safe stress is a stress which is within elastic limit.

$$\text{or } 125 \times 10^6 = \frac{2.1 \times 10^6}{\frac{\pi}{4} (30^2 - d^2)} \text{ or } (30^2 - d^2) = \frac{4 \times 2.1 \times 10^6}{\pi \times 125 \times 10^6}$$

$$\text{or } 0.09 - d^2 = 213.9 \text{ or } 0.09 - 0.02139 = d^2$$

$$\therefore d = \sqrt{0.09 - 0.02139} = 0.2619 \text{ m} = 26.19 \text{ cm. Ans.}$$

**Problem 1.6.** The ultimate stress, for a hollow steel column which carries an axial load of  $1.9 \text{ MN}$  is  $480 \text{ N/mm}^2$ . If the external diameter of the column is  $200 \text{ mm}$ , determine the internal diameter. Take the factor of safety as 4.

Sol. Given :

Ultimate stress,  $= 480 \text{ N/mm}^2$

Axial load,  $P = 1.9 \text{ MN} = 1.9 \times 10^6 \text{ N}$

$$= 1900000 \text{ N}$$

External dia.,  $D = 200 \text{ mm}$

Factor of safety  $= 4$

Let  $d = \text{Internal diameter in mm}$

$\therefore$  Area of cross-section of the column,

$$A = \frac{\pi}{4} (D^2 - d^2) = \frac{\pi}{4} (200^2 - d^2) \text{ mm}^2$$

Using equation (1.7), we get

$$\text{Factor of safety} = \frac{\text{Ultimate stress}}{\text{Working stress or Permissible stress}}$$

$$4 = \frac{480}{\text{Working stress}}$$

$$\text{or Working stress} = \frac{480}{4} = 120 \text{ N/mm}^2$$

$$\therefore \sigma = 120 \text{ N/mm}^2$$

Now using equation (1.1), we get

$$\sigma = \frac{P}{A} \text{ or } 120 = \frac{1900000}{\frac{\pi}{4} (200^2 - d^2)} = \frac{1900000 \times 4}{\pi (40000 - d^2)}$$

$$\text{or } 40000 - d^2 = \frac{1900000 \times 4}{\pi \times 120} = 20159.6$$

$$\text{or } d^2 = 40000 - 20159.6 = 19840.4$$

$$\therefore d = 140.85 \text{ mm. Ans.}$$

**Problem 1.7.** A stepped bar shown in Fig. 1.6 is subjected to an axially applied compressive load of  $35 \text{ kN}$ . Find the maximum and minimum stresses produced.

Sol. Given :

Axial load,  $P = 35 \text{ kN} = 35 \times 10^3 \text{ N}$

Dia. of upper part,  $D_1 = 2 \text{ cm} = 20 \text{ mm}$

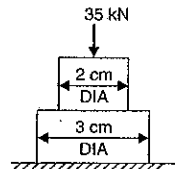

Fig. 1.6



$$\therefore \text{Area of upper part, } A_1 = \frac{\pi}{4} (20^2) = 100 \pi \text{ mm}^2$$

$$\text{Area of lower part, } A_2 = \frac{\pi}{4} D_2^2 = \frac{\pi}{4} (30^2) = 225 \pi \text{ mm}^2$$

The stress is equal to load divided by area. Hence stress will be maximum where area is minimum. Hence stress will be maximum in upper part and minimum in lower part.

$$\therefore \text{Maximum stress} = \frac{\text{Load}}{A_1} = \frac{35 \times 10^3}{100 \times \pi} = 111.408 \text{ N/mm}^2. \text{ Ans.}$$

$$\text{Minimum stress} = \frac{\text{Load}}{A_2} = \frac{35 \times 10^3}{225 \times \pi} = 49.5146 \text{ N/mm}^2. \text{ Ans.}$$

### 1.10. ANALYSIS OF BARS OF VARYING SECTIONS

A bar of different lengths and of different diameters (and hence of different cross-sectional areas) is shown in Fig. 1.6 (a). Let this bar is subjected to an axial load  $P$ .

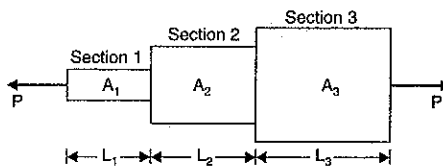

Fig. 1.6 (a)

Though each section is subjected to the same axial load  $P$ , yet the stresses, strains and change in lengths will be different. The total change in length will be obtained by adding the changes in length of individual section.

- Let
- $P$  = Axial load acting on the bar,
  - $L_1$  = Length of section 1,
  - $A_1$  = Cross-sectional area of section 1,
  - $L_2, A_2$  = Length and cross-sectional area of section 2,
  - $L_3, A_3$  = Length and cross-sectional area of section 3, and
  - $E$  = Young's modulus for the bar.

Then stress for the section 1,

$$\sigma_1 = \frac{\text{Load}}{\text{Area of section 1}} = \frac{P}{A_1}$$

Similarly stresses for the section 2 and section 3 are given as,

$$\sigma_2 = \frac{P}{A_2} \text{ and } \sigma_3 = \frac{P}{A_3}$$

Using equation (1.5), the strains in different sections are obtained.

$$\therefore \text{Strain of section 1, } e_1 = \frac{\sigma_1}{E} = \frac{P}{A_1 E} \quad \left( \because \sigma_1 = \frac{P}{A_1} \right)$$

Similarly the strains of section 2 and of section 3 are,

$$e_2 = \frac{\sigma_2}{E} = \frac{P}{A_2 E} \text{ and } e_3 = \frac{\sigma_3}{E} = \frac{P}{A_3 E}$$

$$\text{But strain in section 1} = \frac{\text{Change in length of section 1}}{\text{Length of section 1}}$$

$$\text{or } e_1 = \frac{dL_1}{L_1}$$

where  $dL_1$  = change in length of section 1.

$$\therefore \text{Change in length of section 1, } dL_1 = e_1 L_1$$

$$= \frac{PL_1}{A_1 E} \quad \left( \because e_1 = \frac{P}{A_1 E} \right)$$

Similarly changes in length of section 2 and of section 3 are obtained as :

$$\text{Change in length of section 2, } dL_2 = e_2 L_2$$

$$= \frac{PL_2}{A_2 E} \quad \left( \because e_2 = \frac{P}{A_2 E} \right)$$

and change in length of section 3,  $dL_3 = e_3 L_3$

$$= \frac{PL_3}{A_3 E} \quad \left( \because e_3 = \frac{P}{A_3 E} \right)$$

$\therefore$  Total change in the length of the bar,

$$\begin{aligned} dL &= dL_1 + dL_2 + dL_3 = \frac{PL_1}{A_1 E} + \frac{PL_2}{A_2 E} + \frac{PL_3}{A_3 E} \\ &= \frac{P}{E} \left[ \frac{L_1}{A_1} + \frac{L_2}{A_2} + \frac{L_3}{A_3} \right] \quad \dots(1.8) \end{aligned}$$

Equation (1.8) is used when the Young's modulus of different sections is same. If the Young's modulus of different sections is different, then total change in length of the bar is given by,

$$dL = P \left[ \frac{L_1}{E_1 A_1} + \frac{L_2}{E_2 A_2} + \frac{L_3}{E_3 A_3} \right] \quad \dots(1.9)$$

**Problem 1.8.** An axial pull of 35000 N is acting on a bar consisting of three lengths as shown in Fig. 1.6 (b). If the Young's modulus =  $2.1 \times 10^5 \text{ N/mm}^2$ , determine :

- (i) stresses in each section and
- (ii) total extension of the bar.

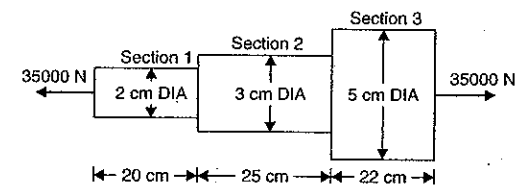

Fig. 1.6 (b)

Sol. Given :

Axial pull,  $P = 35000 \text{ N}$   
 Length of section 1,  $L_1 = 20 \text{ cm} = 200 \text{ mm}$   
 Dia. of section 1,  $D_1 = 2 \text{ cm} = 20 \text{ mm}$

$\therefore$  Area of section 1,  $A_1 = \frac{\pi}{4} (20^2) = 100 \pi \text{ mm}^2$

Length of section 2,  $L_2 = 25 \text{ cm} = 250 \text{ mm}$   
 Dia. of section 2,  $D_2 = 3 \text{ cm} = 30 \text{ mm}$

$\therefore$  Area of section 2,  $A_2 = \frac{\pi}{4} (30^2) = 225 \pi \text{ mm}^2$

Length of section 3,  $L_3 = 22 \text{ cm} = 220 \text{ mm}$   
 Dia. of section 3,  $D_3 = 5 \text{ cm} = 50 \text{ mm}$

$\therefore$  Area of section 3,  $A_3 = \frac{\pi}{4} (50^2) = 625 \pi \text{ mm}^2$

Young's modulus,  $E = 2.1 \times 10^5 \text{ N/mm}^2$ .

(i) Stresses in each section

Stress in section 1,  $\sigma_1 = \frac{\text{Axial load}}{\text{Area of section 1}}$   
 $= \frac{P}{A_1} = \frac{35000}{100 \pi} = 111.408 \text{ N/mm}^2$ . Ans.

Stress in section 2,  $\sigma_2 = \frac{P}{A_2} = \frac{35000}{225 \pi} = 49.5146 \text{ N/mm}^2$ . Ans.

Stress in section 3,  $\sigma_3 = \frac{P}{A_3} = \frac{35000}{625 \pi} = 17.825 \text{ N/mm}^2$ . Ans.

(ii) Total extension of the bar

Using equation (1.8), we get

Total extension  $= \frac{P}{E} \left( \frac{L_1}{A_1} + \frac{L_2}{A_2} + \frac{L_3}{A_3} \right)$   
 $= \frac{35000}{2.1 \times 10^5} \left( \frac{200}{100 \pi} + \frac{250}{225 \pi} + \frac{220}{625 \pi} \right)$   
 $= \frac{35000}{2.1 \times 10^5} (6.366 + 3.536 + 1.120) = 0.183 \text{ mm}$ . Ans.

**Problem 1.9.** A member formed by connecting a steel bar to an aluminium bar is shown in Fig. 1.7. Assuming that the bars are prevented from buckling sideways, calculate the magnitude of force  $P$  that will cause the total length of the member to decrease 0.25 mm. The values of elastic modulus for steel and aluminium are  $2.1 \times 10^5 \text{ N/mm}^2$  and  $7 \times 10^4 \text{ N/mm}^2$  respectively.

Sol. Given :

Length of steel bar,  $L_1 = 30 \text{ cm} = 300 \text{ mm}$

Area of steel bar,  $A_1 = 5 \times 5 = 25 \text{ cm}^2 = 250 \text{ mm}^2$

Elastic modulus for steel bar,  
 $E_1 = 2.1 \times 10^5 \text{ N/mm}^2$

Length of aluminium bar,  
 $L_2 = 38 \text{ cm} = 380 \text{ mm}$

Area of aluminium bar,  
 $A_2 = 10 \times 10 = 100 \text{ cm}^2 = 10000 \text{ mm}^2$

Elastic modulus for aluminium bar,  
 $E_2 = 7 \times 10^4 \text{ N/mm}^2$

Total decrease in length,  $dL = 0.25 \text{ mm}$

Let  $P =$  Required force.

As both the bars are made of different materials, hence total change in the lengths of the bar is given by equation (1.9).

$$\therefore dL = P \left( \frac{L_1}{E_1 A_1} + \frac{L_2}{E_2 A_2} \right)$$

$$\text{or } 0.25 = P \left( \frac{300}{2.1 \times 10^5 \times 2500} + \frac{380}{7 \times 10^4 \times 10000} \right)$$

$$= P (5.714 \times 10^{-7} + 5.428 \times 10^{-7}) = P \times 11.142 \times 10^{-7}$$

$$\therefore P = \frac{0.25}{11.142 \times 10^{-7}} = \frac{0.25 \times 10^7}{11.142}$$

$$= 2.2437 \times 10^5 = 224.37 \text{ kN}$$
. Ans.

**Problem 1.10.** The bar shown in Fig. 1.8 is subjected to a tensile load of 160 kN. If the stress in the middle portion is limited to  $150 \text{ N/mm}^2$ , determine the diameter of the middle portion if the total elongation of the bar is to be 0.2 mm. Young's modulus is given as equal to  $2.1 \times 10^5 \text{ N/mm}^2$ .

Sol. Given :

Tensile load,  $P = 160 \text{ kN} = 160 \times 10^3 \text{ N}$

Stress in middle portion,  $\sigma_2 = 150 \text{ N/mm}^2$

Total elongation,  $dL = 0.2 \text{ mm}$

Total length of the bar,  $L = 40 \text{ cm} = 400 \text{ mm}$

Young's modulus,  $E = 2.1 \times 10^5 \text{ N/mm}^2$

Diameter of both end portions,  $D_1 = 6 \text{ cm} = 60 \text{ mm}$

$\therefore$  Area of cross-section of both end portions,

$$A_1 = \frac{\pi}{4} \times 60^2 = 900 \pi \text{ mm}^2$$

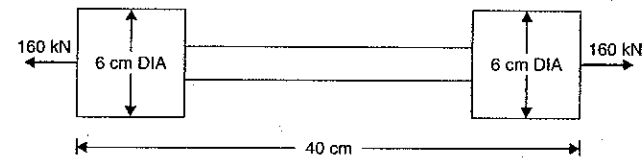

Fig. 1.8

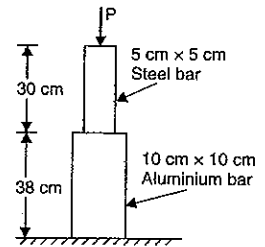

Fig. 1.7

Let  $D_2$  = Diameter of the middle portion  
 $L_2$  = Length of middle portion in mm.  
 $\therefore$  Length of both end portions of the bar,  
 $L_1 = (400 - L_2)$  mm

Using equation (1.1), we have

$$\text{Stress} = \frac{\text{Load}}{\text{Area}}$$

For the middle portion, we have

$$\sigma_2 = \frac{P}{A_2}$$

$$\text{where } A_2 = \frac{\pi}{4} D_2^2$$

or 
$$150 = \frac{160000}{\frac{\pi}{4} D_2^2}$$

$$\therefore D_2^2 = \frac{4 \times 160000}{\pi \times 150} = 1358 \text{ mm}^2$$

or 
$$D_2 = \sqrt{1358} = 36.85 \text{ mm} = 3.685 \text{ cm. Ans.}$$

$\therefore$  Area of cross-section of middle portion,

$$A_2 = \frac{\pi}{4} \times 36.85^2 = 1066 \text{ mm}^2$$

Now using equation (1.8), we get

$$\text{Total extension, } dL = \frac{P}{E} \left[ \frac{L_1}{A_1} + \frac{L_2}{A_2} \right]$$

or 
$$0.2 = \frac{160000}{2.1 \times 10^5} \left[ \frac{(400 - L_2)}{900\pi} + \frac{L_2}{1066} \right]$$
  

$$[\because L_1 = (400 - L_2) \text{ and } A_2 = 1066]$$

or 
$$\frac{0.2 \times 2.1 \times 10^5}{160000} = \frac{(400 - L_2)}{900\pi} + \frac{L_2}{1066}$$

or 
$$0.2625 = \frac{1066(400 - L_2) + 900\pi L_2}{900\pi \times 1066}$$

or 
$$0.2625 \times 900\pi \times 1066 = 1066 \times 400 - 1066 L_2 + 900\pi \times L_2$$

or 
$$791186 = 426400 - 1066 L_2 + 2827 L_2$$

or 
$$791186 - 426400 = L_2 (2827 - 1066)$$

or 
$$364786 = 1761 L_2$$

$\therefore L_2 = \frac{364786}{1761} = 207.14 \text{ mm} = 20.714 \text{ cm. Ans.}$

**1.10.1. Principle of Superposition.** When a number of loads are acting on a body, the resulting strain, according to principle of superposition, will be the algebraic sum of strains caused by individual loads.

While using this principle for an elastic body which is subjected to a number of direct forces (tensile or compressive) at different sections along the length of the body, first the free body diagram of individual section is drawn. Then the deformation of the each section is obtained. The total deformation of the body will be then equal to the algebraic sum of deformations of the individual sections.

**Problem 1.11.** A brass bar, having cross-sectional area of  $1000 \text{ mm}^2$ , is subjected to axial forces as shown in Fig. 1.9.

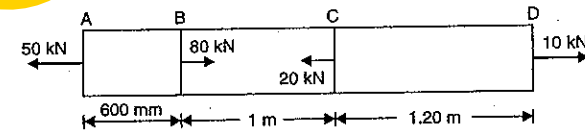

Fig. 1.9

Find the total elongation of the bar. Take  $E = 1.05 \times 10^5 \text{ N/mm}^2$ .

**Sol.** Given :

Area,  $A = 1000 \text{ mm}^2$

Value of  $E = 1.05 \times 10^5 \text{ N/mm}^2$

Let  $dL$  = Total elongation of the bar.

The force of 80 kN acting at B is split up into three forces of 50 kN, 20 kN and 10 kN. Then the part AB of the bar will be subjected to a tensile load of 50 kN, part BC is subjected to a compressive load of 20 kN and part BD is subjected to a compressive load of 10 kN as shown in Fig. 1.10.

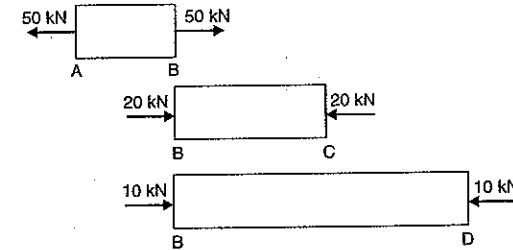

Fig. 1.10

**Part AB.** This part is subjected to a tensile load of 50 kN. Hence there will be increase in length of this part.

$\therefore$  Increase in the length of AB

$$= \frac{P_1}{AE} \times L_1$$

$$= \frac{50 \times 1000}{1000 \times 1.05 \times 10^5} \times 600 \quad (\because P_1 = 50,000 \text{ N, } L_1 = 600 \text{ mm})$$

$$= 0.2857.$$

**Part BC.** This part is subjected to a compressive load of 20 kN or 20,000 N. Hence there will be decrease in length of this part.

$\therefore$  Decrease in the length of BC

$$= \frac{P_2}{AE} \times L_2 = \frac{20,000}{1000 \times 1.05 \times 10^5} \times 1000 \quad (\because L_2 = 1 \text{ m} = 1000 \text{ mm})$$

$$= 0.1904.$$

**Part BD.** This part is subjected to a compressive load of 10 kN or 10,000 N. Hence there will be decrease in length of this part.

∴ Decrease in the length of BD

$$= \frac{P_3}{AE} \times L_3 = \frac{10000}{1000 \times 1.05 \times 10^5} = 2200$$

$$(\because L_3 = 1.2 + 1 = 2.2 \text{ m or } 2200 \text{ mm})$$

$$= 0.2095.$$

∴ Total elongation of bar = 0.2857 - 0.1904 - 0.2095

(Taking +ve sign for increase in length and  
-ve sign for decrease in length)

$$= -0.1142 \text{ mm. Ans.}$$

Negative sign shows, that there will be decrease in length of the bar.

**Problem 1.12.** A member ABCD is subjected to point loads  $P_1$ ,  $P_2$ ,  $P_3$  and  $P_4$  as shown in Fig. 1.11.

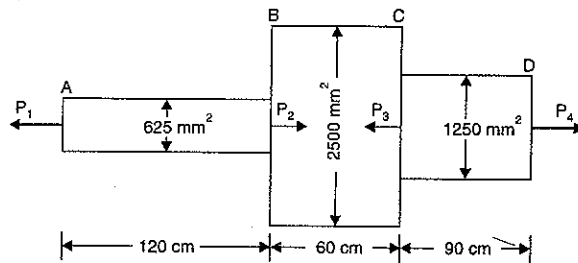

Fig. 1.11

Calculate the force  $P_2$  necessary for equilibrium, if  $P_1 = 45 \text{ kN}$ ,  $P_3 = 450 \text{ kN}$  and  $P_4 = 130 \text{ kN}$ . Determine the total elongation of the member, assuming the modulus of elasticity to be  $2.1 \times 10^5 \text{ N/mm}^2$ .

**Sol. Given :**

Part AB :	Area,	$A_1 = 625 \text{ mm}^2$ and
	Length,	$L_1 = 120 \text{ cm} = 1200 \text{ mm}$
Part BC :	Area,	$A_2 = 2500 \text{ mm}^2$ and
	Length,	$L_2 = 60 \text{ cm} = 600 \text{ mm}$
Part CD :	Area,	$A_3 = 12.0 \text{ mm}^2$ and
	Length,	$L_3 = 90 \text{ cm} = 900 \text{ mm}$
Value of	$E = 2.1 \times 10^5 \text{ N/mm}^2$ .	

Value of  $P_2$  necessary for equilibrium

Resolving the forces on the rod along its axis (i.e., equating the forces acting towards right to those acting towards left), we get

$$P_1 + P_3 = P_2 + P_4$$

But  $P_1 = 45 \text{ kN}$ ,  
 $P_3 = 450 \text{ kN}$  and  $P_4 = 130 \text{ kN}$

$$\therefore 45 + 450 = P_2 + 130 \text{ or } P_2 = 495 - 130 = 365 \text{ kN}$$

The force of 365 kN acting at B is split into two forces of 45 kN and 320 kN (i.e.,  $365 - 45 = 320 \text{ kN}$ ).

The force of 450 kN acting at C is split into two forces of 320 kN and 130 kN (i.e.,  $450 - 320 = 130 \text{ kN}$ ) as shown in Fig. 1.12.

From Fig. 1.12, it is clear that part AB is subjected to a tensile load of 45 kN, part BC is subjected to a compressive load of 320 kN and part CD is subjected to a tensile load 130 kN.

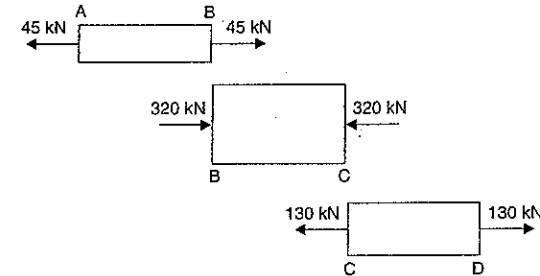

Fig. 1.12

Hence for part AB, there will be increase in length ; for part BC there will be decrease in length and for part CD there will be increase in length.

∴ Increase in length of AB

$$= \frac{P}{A_1 E} \times L_1 = \frac{45000}{625 \times 2.1 \times 10^5} \times 1200 \quad (\because P = 45 \text{ kN} = 45000 \text{ N})$$

$$= 0.4114 \text{ mm}$$

Decrease in length of BC

$$= \frac{P}{A_2 E} \times L_2 = \frac{320,000}{2500 \times 2.1 \times 10^5} \times 600 \quad (\because P = 320 \text{ kN} = 320000 \text{ N})$$

$$= 0.3657 \text{ mm}$$

Increase in length of CD

$$= \frac{P}{A_3 E} \times L_3 = \frac{130,000}{1250 \times 2.1 \times 10^5} \times 900 \quad (\because P = 130 \text{ kN} = 130000 \text{ N})$$

$$= 0.4457 \text{ mm}$$

Total change in the length of member

$$= 0.4114 - 0.3657 + 0.4457$$

(Taking +ve sign for increase in length and  
-ve sign for decrease in length)

$$= 0.4914 \text{ mm (extension). Ans.}$$

**Problem 1.13.** A tensile load of 40 kN is acting on a rod of diameter 40 mm and of length 4 m. A bore of diameter 20 mm is made centrally on the rod. To what length the rod

should be bored so that the total extension will increase 30% under the same tensile load. Take  $E = 2 \times 10^5 \text{ N/mm}^2$ .

Sol. Given :

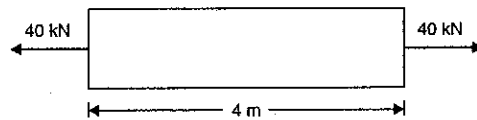

Fig. 1.12 (a)

Tensile load,  $P = 40 \text{ kN} = 40,000 \text{ N}$   
 Dia. of rod,  $D = 40 \text{ mm}$   
 $\therefore$  Area of rod,  $A = \frac{\pi}{4} (40)^2 = 400\pi \text{ mm}^2$

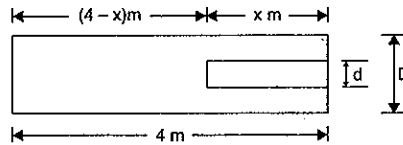

Fig. 1.12 (b)

Length of rod,  $L = 4 \text{ m} = 4 \times 1000 = 4000 \text{ mm}$   
 Dia. of bore,  $d = 20 \text{ mm}$   
 $\therefore$  Area of bore,  $a = \frac{\pi}{4} \times 20^2 = 100\pi \text{ mm}^2$

Total extension after bore =  $1.3 \times$  Extension before bore  
 Value of  $E = 2 \times 10^5 \text{ N/mm}^2$

Let the rod be bored to a length of  $x$  meter or  $x \times 1000 \text{ mm}$ . Then length of unbored portion =  $(4-x) \text{ m} = (4-x) \times 1000 \text{ mm}$ . First calculate the extension before the bore is made.

The extension ( $\delta L$ ) is given by,

$$\delta L = \frac{P}{AE} \times L = \frac{40000 \times 4000}{400\pi \times 2 \times 10^5} = \frac{2}{\pi} \text{ mm}$$

Now extension after the bore is made

$$\begin{aligned} &= 1.3 \times \text{Extension before bore} \\ &= 1.3 \times \frac{2}{\pi} = \frac{2.6}{\pi} \text{ mm} \end{aligned} \quad \dots(i)$$

The extension after the bore is made, is also obtained by finding the extensions of the unbored length and bored length.

For this, find the stresses in the bored and unbored portions.

Stress in unbored portion

$$= \frac{\text{Load}}{\text{Area}} = \frac{P}{A} = \frac{40000}{400\pi} = \frac{100}{\pi} \text{ N/mm}^2$$

$\therefore$  Extension of unbored portion

$$= \frac{\text{Stress}}{E} \times \text{Length of unbored portion}$$

$$= \frac{100}{\pi \times 2 \times 10^5} \times (4-x) \times 1000 = \frac{(4-x)}{2\pi} \text{ mm}$$

Stress in bored portion

$$= \frac{\text{Load}}{\text{Area}} = \frac{P}{(A-a)} = \frac{40000}{(400\pi - 100\pi)} = \frac{40000}{300\pi}$$

$\therefore$  Extension of bored portion

$$\begin{aligned} &= \frac{\text{Stress}}{E} \times \text{Length of bored portion} \\ &= \frac{40000}{300\pi \times 2 \times 10^5} \times 1000x = \frac{4x}{6\pi} \text{ mm} \end{aligned}$$

$\therefore$  Total extension after the bore is made

$$= \frac{(4-x)}{2\pi} + \frac{4x}{6\pi} \quad \dots(ii)$$

Equating the equations (i) and (ii),

$$\frac{2.6}{\pi} = \frac{4-x}{2\pi} + \frac{4x}{6\pi}$$

$$\text{or } 2.6 = \frac{4-x}{2} + \frac{4x}{6} \quad \text{or } 2.6 \times 6 = 3 \times (4-x) + 4x$$

$$\text{or } 15.6 = 12 - 3x + 4x \quad \text{or } 15.6 - 12 = x \quad \text{or } 3.6 = x$$

$\therefore$  Rod should be bored to a length of **3.6 m**. Ans.

**Problem 1.14.** A rigid bar ACDB is hinged at A and supported in a horizontal position by two identical steel wires as shown in Fig. 1.12 (c). A vertical load of 30 kN is applied at B. Find the tensile forces  $T_1$  and  $T_2$  induced in these wires by the vertical load.

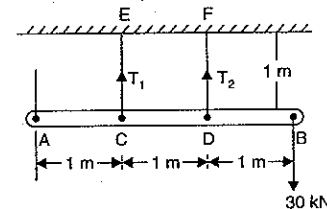

Fig. 1.12 (c)

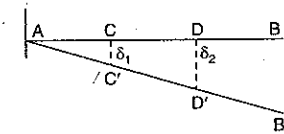

Fig. 1.12 (d)

Sol. Given :

Rigid bar means a bar which will remain straight.

Two identical steel wires mean the area of cross-sections, lengths and value of  $E$  for both wires is same.

$$\therefore A_1 = A_2, E_1 = E_2 \text{ and } L_1 = L_2$$

Load at B = 30 kN = 30,000 N

Fig. 1.12 (c) shows the position of the rigid bar before load is applied at B. Fig. 1.12 (d) shows the position of the rigid bar after load is applied.

Let  $T_1$  = Tension in the first wire  
 $T_2$  = Tension in the second wire  
 $\delta_1$  = Extension of first wire  
 $\delta_2$  = Extension of second wire

Since the rigid bar remains straight, hence the extensions  $\delta_1$  and  $\delta_2$  are given by

$$\frac{\delta_1}{\delta_2} = \frac{AC}{AD} = \frac{1}{2}$$

$$\therefore 2\delta_1 = \delta_2 \quad \dots(i)$$

But  $\delta_1$  is the extension in wire  $EC$

$$\therefore \delta_1 = \frac{\text{Stress in } EC \times L_1}{E_1} = \frac{\left(\frac{T_1}{A_1}\right) \times L_1}{E_1} = \frac{T_1 \times L_1}{A_1 \times E_1}$$

$$\text{Similarly } \delta_2 = \frac{T_2 \times L_2}{A_2 \times E_2}$$

Substituting the values of  $\delta_1$  and  $\delta_2$  in equation (i),

$$2 \times \frac{T_1 \times L_1}{A_1 \times E_1} = \frac{T_2 \times L_2}{A_2 \times E_2}$$

But  $A_1 = A_2$ ,  $E_1 = E_2$  and  $L_1 = L_2$ . Hence above equation becomes

$$\therefore 2T_1 = T_2 \quad \dots(ii)$$

Now taking the moments of all the forces on the rigid bar about A, we get

$$T_1 \times 1 + T_2 \times 2 = 30 \times 3$$

$$\text{or } T_1 + 2T_2 = 90 \quad \dots(iii)$$

Substituting the value of  $T_2$  from equation (ii), into equation (iii), we get

$$T_1 + 2(2T_1) = 90 \quad \text{or } 5T_1 = 90$$

$$\therefore T_1 = \frac{90}{5} = 18 \text{ kN. Ans.}$$

From equation (ii),

$$T_2 = 2 \times 18 = 36 \text{ kN. Ans.}$$

**Note.** After calculating the values of  $T_1$  and  $T_2$ , the stresses in the two wires can also be obtained as :

$$\text{Stress in wire } EC = \frac{\text{Load}}{\text{Area}} = \frac{T_1}{A_1}$$

$$\text{and Stress in wire } FD = \frac{T_2}{A_2}$$

### 11. ANALYSIS OF UNIFORMLY TAPERING CIRCULAR ROD

A bar uniformly tapering from a diameter  $D_1$  at one end to a diameter  $D_2$  at the other end is shown in Fig. 1.13.

Let  $P$  = Axial tensile load on the bar  
 $L$  = Total length of the bar  
 $E$  = Young's modulus.

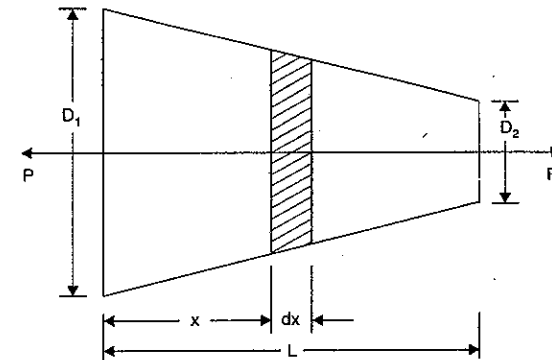

Fig. 1.13

Consider a small element of length  $dx$  of the bar at a distance  $x$  from the left end. Let the diameter of the bar be  $D_x$  at a distance  $x$  from the left end.

$$\begin{aligned} \text{Then } D_x &= D_1 - \left(\frac{D_1 - D_2}{L}\right)x \\ &= D_1 - kx \quad \text{where } k = \frac{D_1 - D_2}{L} \end{aligned}$$

Area of cross-section of the bar at a distance  $x$  from the left end,

$$A_x = \frac{\pi}{4} D_x^2 = \frac{\pi}{4} (D_1 - kx)^2$$

Now the stress at a distance  $x$  from the left end is given by,

$$\begin{aligned} \sigma_x &= \frac{\text{Load}}{A_x} \\ &= \frac{P}{\frac{\pi}{4} (D_1 - kx)^2} = \frac{4P}{\pi (D_1 - kx)^2} \end{aligned}$$

The strain  $e_x$  in the small element of length  $dx$  is obtained by using equation (1.5).

$$\begin{aligned} \therefore e_x &= \frac{\text{Stress}}{E} = \frac{\sigma_x}{E} \\ &= \frac{4P}{\pi (D_1 - kx)^2} \times \frac{1}{E} = \frac{4P}{\pi E (D_1 - kx)^2} \\ \therefore \text{Extension of the small elemental length } dx &= \text{Strain} \cdot dx = e_x \cdot dx \\ &= \frac{4P}{\pi E (D_1 - kx)^2} \cdot dx \quad \dots(i) \end{aligned}$$

Total extension of the bar is obtained by integrating the above equation between the limits 0 and  $L$ .

∴ Total extension,

$$\begin{aligned} dL &= \int_0^L \frac{4P \cdot dx}{\pi E (D_1 - k \cdot x)^2} = \frac{4P}{\pi E} \int_0^L (D_1 - k \cdot x)^{-2} \cdot dx \\ &= \frac{4P}{\pi E} \int_0^L \frac{(D_1 - k \cdot x)^{-2} \times (-k)}{(-k)} \cdot dx \quad [\text{Multiplying and dividing by } (-k)] \\ &= \frac{4P}{\pi E} \left[ \frac{(D_1 - k \cdot x)^{-1}}{(-1) \times (-k)} \right]_0^L = \frac{4P}{\pi E k} \left[ \frac{1}{(D_1 - k \cdot x)} \right]_0^L \\ &= \frac{4P}{\pi E k} \left[ \frac{1}{D_1 - k \cdot L} - \frac{1}{D_1 - k \times 0} \right] \\ &= \frac{4P}{\pi E k} \left[ \frac{1}{D_1 - k \cdot L} - \frac{1}{D_1} \right] \end{aligned}$$

Substituting the value of  $k = \frac{D_1 - D_2}{L}$  in the above equation, we get

Total extension,

$$\begin{aligned} dL &= \frac{4P}{\pi E \cdot \left(\frac{D_1 - D_2}{L}\right)} \left[ \frac{1}{D_1 - \left(\frac{D_1 - D_2}{L}\right) \cdot L} - \frac{1}{D_1} \right] \\ &= \frac{4PL}{\pi E \cdot (D_1 - D_2)} \left[ \frac{1}{D_1 - D_1 + D_2} - \frac{1}{D_1} \right] \\ &= \frac{4PL}{\pi E \cdot (D_1 - D_2)} \left[ \frac{1}{D_2} - \frac{1}{D_1} \right] \\ &= \frac{4PL}{\pi E \cdot (D_1 - D_2)} \times \frac{(D_1 - D_2)}{D_1 D_2} = \frac{4PL}{\pi E D_1 D_2} \quad \dots(1.10) \end{aligned}$$

If the rod is of uniform diameter, then  $D_1 - D_2 = D$

$$\therefore \text{Total extension, } dL = \frac{4PL}{\pi E \cdot D^2} \quad \dots(1.11)$$

**Problem 1.15.** A rod, which tapers uniformly from 40 mm diameter to 20 mm diameter in a length of 400 mm is subjected to an axial load of 5000 N. If  $E = 2.1 \times 10^5 \text{ N/mm}^2$ , find the extension of the rod.

**Sol. Given :**

Larger diameter,	$D_1 = 40 \text{ mm}$
Smaller diameter,	$D_2 = 20 \text{ mm}$
Length of rod,	$L = 400 \text{ mm}$
Axial load,	$P = 5000 \text{ N}$
Young's modulus,	$E = 2.1 \times 10^5 \text{ N/mm}^2$

Let  $dL =$  Total extension of the rod

Using equation (1.10),

$$\begin{aligned} dL &= \frac{4PL}{\pi E D_1 D_2} = \frac{4 \times 5000 \times 400}{\pi \times 2.1 \times 10^5 \times 40 \times 20} \\ &= 0.01515 \text{ mm. Ans.} \end{aligned}$$

**Problem 1.16.** Find the modulus of elasticity for a rod, which tapers uniformly from 30 mm to 15 mm diameter in a length of 350 mm. The rod is subjected to an axial load of 5.5 kN and extension of the rod is 0.025 mm.

**Sol. Given :**

Larger diameter,	$D_1 = 30 \text{ mm}$
Smaller diameter,	$D_2 = 15 \text{ mm}$
Length of rod,	$L = 350 \text{ mm}$
Axial load,	$P = 5.5 \text{ kN} = 5500 \text{ N}$
Extension,	$dL = 0.025 \text{ mm}$

Using equation (1.10), we get

$$dL = \frac{4PL}{\pi E D_1 D_2}$$

or

$$\begin{aligned} E &= \frac{4PL}{\pi D_1 D_2 dL} = \frac{4 \times 5000 \times 350}{\pi \times 30 \times 15 \times 0.025} \\ &= 217865 \text{ N/mm}^2 \text{ or } 2.17865 \times 10^5 \text{ N/mm}^2. \text{ Ans.} \end{aligned}$$

## 1.12. ANALYSIS OF UNIFORMLY TAPERING RECTANGULAR BAR

A bar of constant thickness and uniformly tapering in width from one end to the other end is shown in Fig. 1.14.

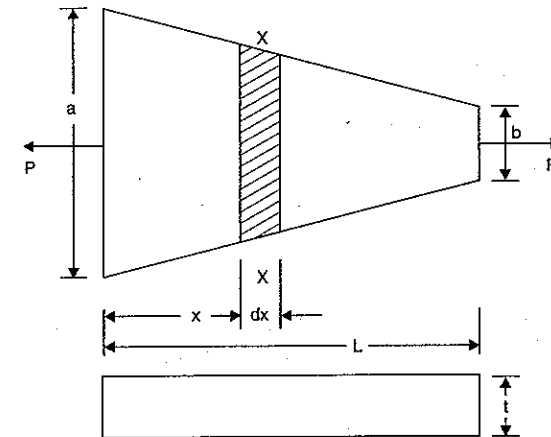

Fig. 1.14

Let  $P$  = Axial load on the bar  
 $L$  = Length of bar  
 $a$  = Width at bigger end  
 $b$  = Width at smaller end  
 $E$  = Young's modulus  
 $t$  = Thickness of bar

Consider any section  $X-X$  at a distance  $x$  from the bigger end.

Width of the bar at the section  $X-X$

$$= a - \frac{(a-b)x}{L}$$

$$= a - kx$$

$$\text{where } k = \frac{a-b}{L}$$

Thickness of bar at section  $X-X = t$

$\therefore$  Area of the section  $X-X$

$$= \text{Width} \times \text{thickness}$$

$$= (a - kx)t$$

$\therefore$  Stress on the section  $X-X$

$$= \frac{\text{Load}}{\text{Area}} = \frac{P}{(a - kx)t}$$

Extension of the small elemental length  $dx$

$$= \text{Strain} \times \text{Length } dx$$

$$= \frac{\text{Stress}}{E} \times dx \quad \left( \because \text{Strain} = \frac{\text{Stress}}{E} \right)$$

$$= \frac{\left( \frac{P}{(a - kx)t} \right)}{E} \times dx \quad \left( \because \text{Stress} = \frac{P}{(a - kx)t} \right)$$

$$= \frac{P}{E(a - kx)t} dx$$

Total extension of the bar is obtained by integrating the above equation between the limits 0 and  $L$ .

$\therefore$  Total extension,

$$\begin{aligned} dL &= \int_0^L \frac{P}{E(a - kx)t} dx = \frac{P}{Et} \int_0^L \frac{dx}{(a - kx)} \\ &= \frac{P}{Et} \cdot \log_e \left[ (a - kx) \right]_0^L \times \left( -\frac{1}{k} \right) = -\frac{P}{Eth} [\log_e (a - kL) - \log_e a] \\ &= \frac{P}{Eth} [\log_e a - \log_e (a - kL)] = \frac{P}{Eth} \left[ \log_e \left( \frac{a}{a - kL} \right) \right] \\ &= \frac{P}{Et \left( \frac{a-b}{L} \right)} \left[ \log_e \left( \frac{a}{a - \left( \frac{a-b}{L} \right) L} \right) \right] \quad \left( \because k = \frac{a-b}{L} \right) \end{aligned}$$

$$= \frac{PL}{Et(a-b)} \log_e \frac{a}{b} \quad \dots(1.12)$$

**Problem 1.17.** A rectangular bar made of steel is 2.8 m long and 15 mm thick. The rod is subjected to an axial tensile load of 40 kN. The width of the rod varies from 75 mm at one end to 30 mm at the other. Find the extension of the rod if  $E = 2 \times 10^5 \text{ N/mm}^2$ .

**Sol. Given :**

Length,  $L = 2.8 \text{ m} = 2800 \text{ mm}$

Thickness,  $t = 15 \text{ mm}$

Axial load,  $P = 40 \text{ kN} = 40,000 \text{ N}$

Width at bigger end,  $a = 75 \text{ mm}$

Width at smaller end,  $b = 30 \text{ mm}$

Value of  $E = 2 \times 10^5 \text{ N/mm}^2$

Let  $dL$  = Extension of the rod.

Using equation (1.12), we get

$$\begin{aligned} dL &= \frac{PL}{Et(a-b)} \log_e \frac{a}{b} \\ &= \frac{40000 \times 2800}{2 \times 10^5 \times 15(75 - 30)} \log_e \left( \frac{75}{30} \right) \\ &= 0.8296 \times 0.9163 = \mathbf{0.76 \text{ mm. Ans.}} \end{aligned}$$

**Problem 1.18.** The extension in a rectangular steel bar of length 400 mm and thickness 10 mm, is found to be 0.21 mm. The bar tapers uniformly in width from 100 mm to 50 mm. If  $E$  for the bar is  $2 \times 10^5 \text{ N/mm}^2$ , determine the axial load on the bar.

**Sol. Given :**

Extension,  $dL = 0.21 \text{ mm}$

Length,  $L = 400 \text{ mm}$

Thickness,  $t = 10 \text{ mm}$

Width at bigger end,  $a = 100 \text{ mm}$

Width at smaller end,  $b = 50 \text{ mm}$

Value of  $E = 2 \times 10^5 \text{ N/mm}^2$

Let  $P$  = axial load.

Using equation (1.12), we get

$$dL = \frac{PL}{Et(a-b)} \log_e \left( \frac{a}{b} \right)$$

or

$$\begin{aligned} 0.21 &= \frac{P \times 400}{2 \times 10^5 \times 10(100 - 50)} \log_e \left( \frac{100}{50} \right) \\ &= 0.000004 P \times 0.6931 \end{aligned}$$

$$\begin{aligned} \therefore P &= \frac{0.21}{0.000004 \times 0.6931} = 75746 \text{ N} \\ &= \mathbf{75.746 \text{ kN. Ans.}} \end{aligned}$$



### 1.13. ANALYSIS OF BARS OF COMPOSITE SECTIONS

A bar, made up of two or more bars of equal lengths but of different materials rigidly fixed with each other and behaving as one unit for extension or compression when subjected to an axial tensile or compressive loads, is called a composite bar. For the composite bar the following two points are important :

1. The extension or compression in each bar is equal. Hence deformation per unit length *i.e.*, strain in each bar is equal.
2. The total external load on the composite bar is equal to the sum of the loads carried by each different material.

Fig. 1.15 shows a composite bar made up of two different materials.

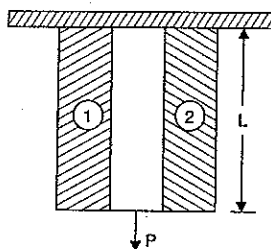

Fig. 1.15

- Let
- $P$  = Total load on the composite bar,
  - $L$  = Length of composite bar and also length of bars of different materials,
  - $A_1$  = Area of cross-section of bar 1,
  - $A_2$  = Area of cross-section of bar 2,
  - $E_1$  = Young's Modulus of bar 1,
  - $E_2$  = Young's Modulus of bar 2,
  - $P_1$  = Load shared by bar 1,
  - $P_2$  = Load shared by bar 2,
  - $\sigma_1$  = Stress induced in bar 1, and
  - $\sigma_2$  = Stress induced in bar 2.

Now the total load on the composite bar is equal to the sum of the load carried by the two bars.

$$\therefore P = P_1 + P_2 \quad \dots(i)$$

$$\text{The stress in bar 1,} \quad = \frac{\text{Load carried by bar 1}}{\text{Area of cross-section of bar 1}}$$

$$\therefore \sigma_1 = \frac{P_1}{A_1} \quad \text{or} \quad P_1 = \sigma_1 A_1 \quad \dots(ii)$$

$$\text{Similarly stress in bar 2,} \quad \sigma_2 = \frac{P_2}{A_2} \quad \text{or} \quad P_2 = \sigma_2 A_2 \quad \dots(iii)$$

Substituting the values of  $P_1$  and  $P_2$  in equation (i), we get

$$P = \sigma_1 A_1 + \sigma_2 A_2 \quad \dots(iv)$$

Since the ends of the two bars are rigidly connected, each bar will change in length by the same amount. Also the length of each bar is same and hence the ratio of change in length to the original length (*i.e.*, strain) will be same for each bar.

$$\text{But strain in bar 1,} \quad = \frac{\text{Stress in bar 1}}{\text{Young's modulus of bar 1}} = \frac{\sigma_1}{E_1}$$

$$\text{Similarly strain in bar 2,} \quad = \frac{\sigma_2}{E_2}$$

But strain in bar 1 = Strain in bar 2

$$\therefore \frac{\sigma_1}{E_1} = \frac{\sigma_2}{E_2} \quad \dots(v)$$

From equations (iv) and (v), the stresses  $\sigma_1$  and  $\sigma_2$  can be determined. By substituting the values of  $\sigma_1$  and  $\sigma_2$  in equations (ii) and (iii), the load carried by different materials may be computed.

**Modular Ratio.** The ratio of  $\frac{E_1}{E_2}$  is called the modular ratio of the first material to the second.

**Problem 1.19.** A steel rod of 3 cm diameter is enclosed centrally in a hollow copper tube of external diameter 5 cm and internal diameter of 4 cm. The composite bar is then subjected to an axial pull of 45000 N. If the length of each bar is equal to 15 cm, determine :

- (i) The stresses in the rod and tube, and
- (ii) Load carried by each bar.

Take  $E$  for steel =  $2.1 \times 10^5$  N/mm<sup>2</sup> and for copper =  $1.1 \times 10^5$  N/mm<sup>2</sup>.

**Sol.** Given :

Dia. of steel rod = 3 cm = 30 mm

$\therefore$  Area of steel rod,

$$A_s = \frac{\pi}{4} (30)^2 = 706.86 \text{ mm}^2$$

External dia. of copper tube = 5 cm = 50 mm

Internal dia. of copper tube = 4 cm = 40 mm

$\therefore$  Area of copper tube,

$$A_c = \frac{\pi}{4} [50^2 - 40^2] \text{ mm}^2 = 706.86 \text{ mm}^2$$

Axial pull on composite bar,  $P = 45000$  N

Length of each bar,  $L = 15$  cm

Young's modulus for steel,  $E_s = 2.1 \times 10^5$  N/mm<sup>2</sup>

Young's modulus for copper,  $E_c = 1.1 \times 10^5$  N/mm<sup>2</sup>

(i) The stress in the rod and tube

- Let
- $\sigma_s$  = Stress in steel,
  - $P_s$  = Load carried by steel rod,
  - $\sigma_c$  = Stress in copper, and
  - $P_c$  = Load carried by copper tube.

Now strain in steel = Strain in copper

$$\text{or} \quad \frac{\sigma_s}{E_s} = \frac{\sigma_c}{E_c} \quad \left( \because \frac{\sigma}{E} = \text{strain} \right)$$

$$\therefore \frac{\sigma_s}{E_s} \times \sigma_c = \frac{2.1 \times 10^5}{1.1 \times 10^5} \times \sigma_c = 1.909 \sigma_c \quad \dots(i)$$

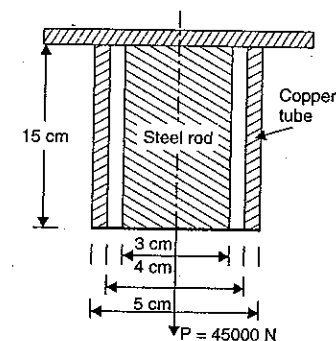

Fig. 1.16

Now  $\text{stress} = \frac{\text{Load}}{\text{Area}}$ ,  $\therefore \text{Load} = \text{Stress} \times \text{Area}$

Load on steel + Load on copper = Total load

$$\sigma_s \times A_s + \sigma_c \times A_c = P \quad (\because \text{Total load} = P)$$

$$\text{or } 1.909 \sigma_c \times 706.86 + \sigma_c \times 706.86 = 45000$$

$$\text{or } \sigma_c (1.909 \times 706.86 + 706.86) = 45000$$

$$\text{or } 2056.25 \sigma_c = 45000$$

$$\therefore \sigma_c = \frac{45000}{2056.25} = 21.88 \text{ N/mm}^2. \text{ Ans.}$$

Substituting the value of  $\sigma_c$  in equation (i), we get

$$\sigma_s = 1.909 \times 21.88 \text{ N/mm}^2 \\ = 41.77 \text{ N/mm}^2. \text{ Ans.}$$

(ii) Load carried by each bar.

As  $\text{load} = \text{Stress} \times \text{Area}$

$\therefore$  Load carried by steel rod,

$$P_s = \sigma_s \times A_s \\ = 41.77 \times 706.86 = 29525.5 \text{ N. Ans.}$$

Load carried by copper tube,

$$P_c = 45000 - 29525.5 \\ = 15474.5 \text{ N. Ans.}$$

**Problem 1.20.** A compound tube consists of a steel tube 140 mm internal diameter and 160 mm external diameter and an outer brass tube 160 mm internal diameter and 180 mm external diameter. The two tubes are of the same length. The compound tube carries an axial load of 900 kN. Find the stresses and the load carried by each tube and the amount it shortens. Length of each tube is 140 mm. Take  $E$  for steel as  $2 \times 10^5 \text{ N/mm}^2$  and for brass as  $1 \times 10^5 \text{ N/mm}^2$ .

**Sol. Given :**

Internal dia. of steel tube = 140 mm

External dia. of steel tube = 160 mm

$$\therefore \text{Area of steel tube, } A_s = \frac{\pi}{4} (160^2 - 140^2) = 4712.4 \text{ mm}^2$$

Internal dia. of brass tube = 160 mm

External dia. of brass tube = 180 mm

$$\therefore \text{Area of brass tube, } A_b = \frac{\pi}{4} (180^2 - 160^2) = 5340.7 \text{ mm}^2$$

Axial load carried by compound tube,

$$P = 900 \text{ kN} = 900 \times 1000 = 900000 \text{ N}$$

Length of each tube,  $L = 140 \text{ mm}$

$E$  for steel,  $E_s = 2 \times 10^5 \text{ N/mm}^2$

$E$  for brass,  $E_b = 1 \times 10^5 \text{ N/mm}^2$

Let  $\sigma_s = \text{Stress in steel in N/mm}^2$  and

$\sigma_b = \text{Stress in brass in N/mm}^2$

Now strain in steel = Strain in brass

$$\frac{\sigma_s}{E_s} = \frac{\sigma_b}{E_b} \quad \left( \because \text{Strain} = \frac{\text{Stress}}{E} \right)$$

$$\therefore \sigma_s = \frac{E_s}{E_b} \times \sigma_b = \frac{2 \times 10^5}{1 \times 10^5} \sigma_b = 2\sigma_b \quad \dots(i)$$

Now load on steel + Load on brass = Total load

$$\text{or } \sigma_s \times A_s + \sigma_b \times A_b = 900000 \quad (\because \text{Load} = \text{Stress} \times \text{Area})$$

$$\text{or } 2\sigma_b \times 4712.4 + \sigma_b \times 5340.7 = 900000 \quad (\because \sigma_s = 2\sigma_b)$$

$$\text{or } 14765.5 \sigma_b = 900000$$

$$\therefore \sigma_b = \frac{900000}{14765.5} = 60.95 \text{ N/mm}^2. \text{ Ans.}$$

Substituting the value of  $\sigma_b$  in equation (i), we get

$$\sigma_s = 2 \times 60.95 = 121.9 \text{ N/mm}^2. \text{ Ans.}$$

Load carried by brass tube

= Stress  $\times$  Area

$$= \sigma_b \times A_b = 60.95 \times 5340.7 \text{ N}$$

$$= 325515 \text{ N} = 325.515 \text{ kN. Ans.}$$

Load carried by steel tube

$$= 900 - 325.515 = 574.485 \text{ kN. Ans.}$$

Decrease in the length of the compound tube

= Decrease in length of either of the tubes

= Decrease in length of brass tube

= Strain in brass tube  $\times$  Original length

$$= \frac{\sigma_b}{E_b} \times L = \frac{60.95}{1 \times 10^5} \times 140 = 0.0853 \text{ mm. Ans.}$$

**Problem 1.21.** Two vertical rods one of steel and the other of copper are each rigidly fixed at the top and 50 cm apart. Diameters and lengths of each rod are 2 cm and 4 m respectively. A cross bar fixed to the rods at the lower ends carries a load of 5000 N such that the cross bar remains horizontal even after loading. Find the stress in each rod and the position of the load on the bar. Take  $E$  for steel =  $2 \times 10^5 \text{ N/mm}^2$  and  $E$  for copper =  $1 \times 10^5 \text{ N/mm}^2$ .

**Sol. Given :**

Distance between the rods

$$= 50 \text{ cm} = 500 \text{ mm}$$

Dia. of steel rod

$$= \text{Dia. of copper rod}$$

$$= 2 \text{ cm} = 20 \text{ mm}$$

$\therefore$  Area of steel rod

$$= \text{Area of copper rod}$$

$$= \frac{\pi}{4} \times (20)^2 = 100 \pi \text{ mm}^2$$

$$\therefore A_s = A_c = 100 \pi \text{ mm}^2$$

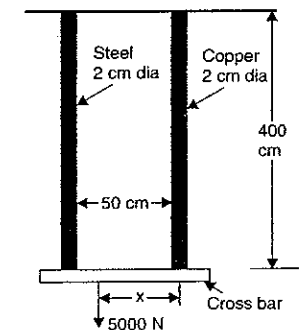

Fig. 1.17

**Problem 1.25.** Two brass rods and one steel rod together support a load as shown in Fig. 1.20. If the stresses in brass and steel are not to exceed  $60 \text{ N/mm}^2$  and  $120 \text{ N/mm}^2$ , find the safe load that can be supported. Take  $E$  for steel  $= 2 \times 10^5 \text{ N/mm}^2$  and for brass  $= 1 \times 10^5 \text{ N/mm}^2$ . The cross-sectional area of steel rod is  $1500 \text{ mm}^2$  and of each brass rod is  $1000 \text{ mm}^2$ .

**Sol. Given :**

Stress in brass,	$\sigma_b = 60 \text{ N/mm}^2$
Stress in steel,	$\sigma_s = 120 \text{ N/mm}^2$
$E$ for steel,	$E_s = 2 \times 10^5 \text{ N/mm}^2$
$E$ for brass,	$E_b = 1 \times 10^5 \text{ N/mm}^2$
Area of steel rod,	$A_s = 1500 \text{ mm}^2$
Area of two brass rods,	$A_b = 2 \times 1000$ $= 2000 \text{ mm}^2$
Length of steel rod,	$L_s = 170 \text{ mm}$
Length of brass rods,	$L_b = 100 \text{ mm}$

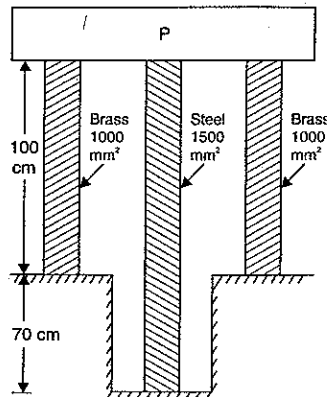

Fig. 1.20

We know that decrease in the length of steel rod should be equal to the decrease in length of brass rods.

But decrease in length of steel rods

$$= \text{Strain in steel rod} \times \text{Length of steel rod}$$

$$= e_s \times L_s \text{ where } e_s \text{ is strain in steel}$$

Similarly decrease in length of brass rods

$$= \text{Strain in brass rods} \times \text{Length of brass rods}$$

$$= e_b \times L_b \text{ where } e_b \text{ is strain in brass rod}$$

Equating the decrease in length of steel rods to the decrease in length of brass rods, we get

$$e_s L_s = e_b \times L_b \quad \text{or} \quad \frac{e_s}{e_b} = \frac{L_b}{L_s} = \frac{100}{170}$$

But stress in steel = Strain in steel  $\times E_s$  ( $\because$  Stress = Strain  $\times E$ )

$$\text{or} \quad \sigma_s = e_s \times E_s \quad \dots(i)$$

Similarly stress in brass is given by,

$$\sigma_b = e_b \times E_b \quad \dots(ii)$$

Dividing equation (i) by equation (ii), we get

$$\frac{\sigma_s}{\sigma_b} = \frac{e_s \times E_s}{e_b \times E_b} = \frac{100}{170} \times \frac{2 \times 10^5}{1 \times 10^5} = 1.176$$

Suppose steel is permitted to reach its safe stress of  $2 \times 10^5 \text{ N/mm}^2$ , the corresponding stress in brass will be

$$\left( \sigma_b = \frac{\sigma_s}{1.176} = \frac{2 \times 10^5}{1.176} = 1.7 \times 10^5 \text{ N/mm}^2 \right)$$

$1.7 \times 10^5 \text{ N/mm}^2$  which exceeds the safe stress of  $1 \times 10^5 \text{ N/mm}^2$  for brass. Therefore let brass be allowed to reach its safe stress of  $1 \times 10^5 \text{ N/mm}^2$ . Then corresponding stress in steel will be  $1.176 \times 10^5 \text{ N/mm}^2$  which is less than  $2 \times 10^5 \text{ N/mm}^2$ .

$$\therefore \text{Total load} = P = \text{Load on steel} + \text{Load on copper}$$

$$= \sigma_s \times A_s + \sigma_b \times A_b$$

$$= 1.176 \times 10^5 \times 1500 + 1 \times 10^5 \times 2000$$

$$= 3764 \times 10^5 \text{ N} \quad \text{or} \quad 376.4 \times 10^6 \text{ N}$$

$$= 376.4 \text{ MN. Ans.} \quad (\because M = 10^6)$$

**Problem 1.26.** Three bars made of copper, zinc and aluminium are of equal length and have cross-section 500, 750 and 1000 square mm respectively. They are rigidly connected at their ends. If this compound member is subjected to a longitudinal pull of 250 kN, estimate the proportional of the load carried on each rod and the induced stresses. Take the value of  $E$  for copper  $= 1.3 \times 10^5 \text{ N/mm}^2$ , for zinc  $= 1.0 \times 10^5 \text{ N/mm}^2$  and for aluminium  $= 0.8 \times 10^5 \text{ N/mm}^2$ .

**Sol. Given :**

$$\text{Total load,} \quad P = 250 \text{ kN} = 250 \times 10^3 \text{ N}$$

For copper bar,

$$\text{Area, } A_c = 500 \text{ mm}^2 \quad \text{and} \quad E_c = 1.3 \times 10^5 \text{ N/mm}^2$$

For zinc bar,

$$\text{Area, } A_z = 750 \text{ mm}^2 \quad \text{and} \quad E_z = 1.0 \times 10^5 \text{ N/mm}^2$$

For aluminium bar,

$$\text{Area, } A_a = 1000 \text{ mm}^2, \quad \text{and} \quad E_a = 0.8 \times 10^5 \text{ N/mm}^2$$

Let  $\sigma_c$  = Stress induced in copper bar,

$\sigma_z$  = Stress induced in zinc bar,

$\sigma_a$  = Stress induced in aluminium bar,

$P_c$  = Load shared by copper rod,

$P_z$  = Load shared by zinc rod,

$P_a$  = Load shared by aluminium rod, and

$L$  = Length of each bar.

Now, we know that the increase in length of each bar should be same, as length of each bar is equal hence strain in each bar will be same.

$$\therefore \text{Strain in copper} = \text{Strain in zinc} = \text{Strain in aluminium}$$

$$\text{or} \quad \frac{\text{Stress in copper}}{E_c} = \frac{\text{Stress in zinc}}{E_z} = \frac{\text{Stress in aluminium}}{E_a}$$

$$\text{or} \quad \frac{\sigma_c}{E_c} = \frac{\sigma_z}{E_z} = \frac{\sigma_a}{E_a}$$

$$\therefore \sigma_c = \frac{E_c}{E_a} \times \sigma_a = \frac{1.3 \times 10^5}{0.8 \times 10^5} \sigma_a = 1.625 \sigma_a \quad \dots(i)$$

$$\text{Also} \quad \sigma_z = \frac{E_z}{E_a} \times \sigma_a = \frac{1.0 \times 10^5}{0.8 \times 10^5} \times \sigma_a = 1.25 \sigma_a \quad \dots(ii)$$

Now total load = Load on copper + Load on zinc + Load on aluminium

$$\text{or} \quad 250 \times 10^3 = \text{Stress in copper} \times A_c + \text{Stress in zinc} \times A_z + \text{Stress in aluminium} \times A_a$$

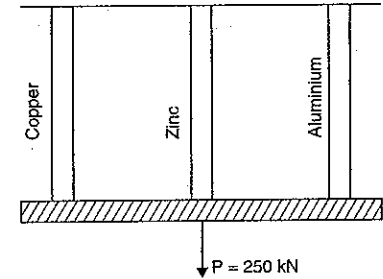

Fig. 1.21

$$\begin{aligned}
 &= \sigma_c \times A_c + \sigma_z \times A_z + \sigma_a \times A_a \\
 &= 1.625\sigma_a \times 500 + 1.25\sigma_a \times 750 + \sigma_a \times 1000 \\
 &= 2750\sigma_a \quad (\because \sigma_c = 1.625\sigma_a \text{ and } \sigma_z = 1.25\sigma_a)
 \end{aligned}$$

$$\sigma_a = \frac{250 \times 10^3}{2750} = 90.9 \text{ N/mm}^2. \text{ Ans.}$$

Substituting the value of  $\sigma_a$  in equations (i) and (ii), we get

$$\sigma_c = 1.625 \times 90.9 = 147.7 \text{ N/mm}^2. \text{ Ans.}$$

$$\text{and } \sigma_z = 1.25 \times 90.9 = 113.625 \text{ N/mm}^2. \text{ Ans.}$$

$$\begin{aligned}
 \text{Now load shared by copper} &= \sigma_c \times A_c \\
 &= 147.7 \times 500 = 73850 \text{ N. Ans.}
 \end{aligned}$$

$$\begin{aligned}
 \text{Load shared by zinc rod} &= \sigma_z \times A_z = 113.625 \times 750 \\
 &= 85218 \text{ N. Ans.}
 \end{aligned}$$

$$\begin{aligned}
 \text{Load shared by aluminium rod} &= \sigma_a \times A_a = 90.9 \times 1000 \\
 &= 90900 \text{ N. Ans.}
 \end{aligned}$$

**Problem 1.27.** A steel rod 20 mm in diameter passes centrally through a steel tube of 25 mm internal diameter and 30 mm external diameter. The tube is 800 mm long and is closed by rigid washers of negligible thickness which are fastened by nuts threaded on the rod. The nuts are tightened until the compressive load on the tube is 20 kN. Calculate the stresses in the tube and the rod.

Find the increase in these stresses when one nut is tightened by one-quarter of a turn relative to the other. There are 4 threads per 10 mm. Take  $E = 2 \times 10^5 \text{ N/mm}^2$ .

**Sol.** Given :

$$\text{Dia. of rod} = 20 \text{ mm}$$

$$\therefore \text{Area of rod, } A_r = \frac{\pi}{4} (20)^2 \text{ mm}^2 = 100\pi \text{ mm}^2$$

$$\text{Area of tube, } A_t = \frac{\pi}{4} (30^2 - 25^2) \text{ mm}^2 = 68.75\pi \text{ mm}^2$$

$$\text{Length of tube, } L = 800 \text{ mm}$$

$$\text{Compressive load on tube, } P_t = 20 \text{ kN} = 20 \times 10^3 \text{ N}$$

$$\text{Value of } E = 2 \times 10^5 \text{ N/mm}^2$$

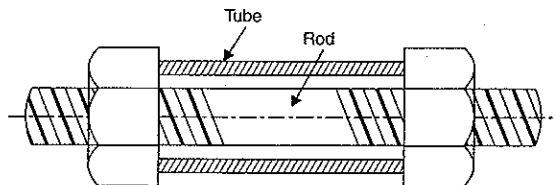

Fig. 1.22

When the nuts are tightened, the tube will be compressed and the rod will be elongated. This means that the tube will be under compression and rod will be under tension. Since no

external forces have been applied, the compressive load on the tube must be equal to the tensile load on the rod.

$$\begin{aligned}
 \text{Let } \sigma_t &= \text{Stress in the tube, and} \\
 \sigma_r &= \text{Stress in the rod}
 \end{aligned}$$

Now, Tensile load on the rod = Compressive load on the tube

$$\therefore \sigma_r \times A_r = \sigma_t \times A_t$$

or

$$\sigma_r = \frac{A_t}{A_r} \times \sigma_t = \frac{68.75\pi}{100\pi} \times \sigma_t = 0.6875\sigma_t \quad \dots(i)$$

(i) When the compressive load on the tube is 20 kN or 20,000 N.

Then stress in the tube,

$$\begin{aligned}
 \sigma_t &= \frac{\text{Load}}{\text{Area of tube}} = \frac{20000}{68.75\pi} \\
 &= 92.599 \text{ N/mm}^2 \text{ (compressive). Ans.}
 \end{aligned}$$

(ii) Substituting this value in equation (i), we get

$$\begin{aligned}
 \therefore \text{Stress in the rod, } \sigma_r &= 0.6875 \times \sigma_t = 0.6875 \times 92.599 \\
 &= 63.66 \text{ N/mm}^2 \text{ (tensile). Ans.}
 \end{aligned}$$

(iii) Stresses in the rod and tube, when one nut is tightened by one quarter of a turn.

Let  $\sigma_r^*$  = Stress in the rod and

$\sigma_t^*$  = Stress in the tube due to tightening of the nut by one-quarter of a turn.

As the stress in the tube is compressive and stress in the rod is tensile hence there will be decrease in the length of tube but there will be increase in the length of the rod.

$\therefore$  Decrease in the length of tube

$$\begin{aligned}
 &= \text{Strain} \times L \\
 &= \frac{\text{Stress in tube}}{E} \times L \quad \left( \because \text{Strain} = \frac{\text{Stress}}{E} \right) \\
 &= \frac{\sigma_t^*}{2 \times 10^5} \times 800 = 0.004 \times \sigma_t^*
 \end{aligned}$$

Increase in the length of the rod

$$\begin{aligned}
 &= \frac{\text{Stress in rod}}{E} \times L = \frac{\sigma_r^*}{E} \times L \\
 &= \frac{\sigma_r^*}{2 \times 10^5} \times 800 = \frac{(0.6875 \times \sigma_t^*) \times 800}{2 \times 10^5} \quad (\because \sigma_r = 0.6875\sigma_t) \\
 &= 0.00275 \times \sigma_t^*
 \end{aligned}$$

Axial advancement of the nut = One-quarter of a turn

$$= \frac{1}{4} \text{ of a turn}$$

But in one turn, the advancement of the nut is  $\frac{1}{4}$ th of 10 mm.

$$\therefore \text{Axial advancement of the nut} = \frac{1}{4} \times \frac{1}{4} \times 10 = 0.625 \text{ mm}$$

But axial advancement of the nut

$$= \text{Decrease in length of tube} + \text{Increase in the length of rod}$$

$$\therefore 0.625 = 0.004 \times \sigma_t^* + 0.00275\sigma_t^* = 0.00675 \times \sigma_t^*$$

$$\therefore \sigma_t^* = \frac{0.625}{0.00675} = 92.59 \text{ N/mm}^2. \text{ Ans.}$$

$$\text{and } \sigma_r^* = 0.6875 \times 92.59 = 63.65 \text{ N/mm}^2. \text{ Ans.}$$

### 1.14. THERMAL STRESSES

Thermal stresses are the stresses induced in a body due to change in temperature. Thermal stresses are set up in a body, when the temperature of the body is raised or lowered and the body is not allowed to expand or contract freely. But if the body is allowed to expand or contract freely, no stresses will be set up in the body.

Consider a body which is heated to a certain temperature.

Let  $L$  = Original length of the body,  
 $T$  = Rise in temperature,  
 $E$  = Young's Modulus  
 $\alpha$  = Co-efficient of linear expansion.  
 $dL$  = Extension of rod due to rise of temperature.

If the rod is free to expand, then extension of the rod is given by

$$dL = \alpha \cdot T \cdot L. \quad \dots(1.13)$$

This is shown in Fig. 1.23 (a) in which  $AB$  represents the original length and  $BB'$  represents the increase in length due to temperature rise. Now suppose that an external compressive load,  $P$  is applied at  $B'$  so that the rod is decreased in its length from  $(L + \alpha TL)$  to  $L$  as shown in Figs. 1.23 (b) and (c).

$$\begin{aligned} \text{Then compressive strain} &= \frac{\text{Decrease in length}}{\text{Original length}} \\ &= \frac{\alpha \cdot T \cdot L}{L + \alpha \cdot T \cdot L} = \frac{\alpha TL}{L} = \alpha \cdot T \end{aligned}$$

$$\text{But } \frac{\text{Stress}}{\text{Strain}} = E$$

$$\therefore \text{Stress} = \text{Strain} \times E = \alpha \cdot T \cdot E$$

$$\text{And load or thrust on the rod} = \text{Stress} \times \text{Area} = \alpha \cdot T \cdot E \times A$$

If the ends of the body are fixed to rigid supports, so that its expansion is prevented, then compressive stress and strain will be set up in the rod. These stresses and strains are known as thermal stresses and thermal strain.

$$\begin{aligned} \therefore \text{Thermal strain, } e &= \frac{\text{Extension prevented}}{\text{Original length}} \\ &= \frac{dL}{L} = \frac{\alpha \cdot T \cdot L}{L} = \alpha \cdot T \end{aligned} \quad \dots(1.14)$$

$$\begin{aligned} \text{And thermal stress, } \sigma &= \text{Thermal strain} \times E \\ &= \alpha \cdot T \cdot E. \end{aligned} \quad \dots(1.15)$$

Thermal stress is also known as temperature stress.

And thermal strain is also known as temperature strain.

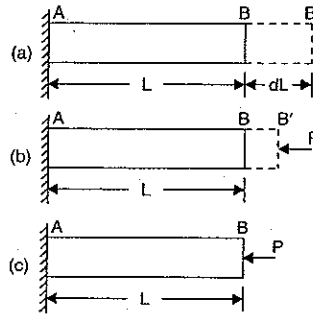

Fig. 1.23

**1.14.1. Stress and Strain when the Supports Yield.** If the supports yield by an amount equal to  $\delta$ , then the actual expansion

$$\begin{aligned} &= \text{Expansion due to rise in temperature} - \delta \\ &= \alpha \cdot T \cdot L - \delta. \end{aligned}$$

$$\therefore \text{Actual strain} = \frac{\text{Actual expansion}}{\text{Original length}} = \frac{(\alpha \cdot T \cdot L - \delta)}{L}$$

$$\text{And actual stress} = \text{Actual strain} \times E$$

$$= \frac{(\alpha \cdot T \cdot L - \delta)}{L} \times E. \quad \dots(1.16)$$

**Problem 1.28.** A rod is 2 m long at a temperature of  $10^\circ\text{C}$ . Find the expansion of the rod, when the temperature is raised to  $80^\circ\text{C}$ . If this expansion is prevented, find the stress induced in the material of the rod. Take  $E = 1.0 \times 10^5 \text{ MN/m}^2$  and  $\alpha = 0.000012$  per degree centigrade.

**Sol.** Given :

Length of rod,  $L = 2 \text{ m} = 200 \text{ cm}$

Initial temperature,  $T_1 = 10^\circ\text{C}$

Final temperature,  $T_2 = 80^\circ\text{C}$

$\therefore$  Rise in temperature,  $T = T_2 - T_1 = 80^\circ - 10^\circ = 70^\circ\text{C}$

Young's Modulus,  $E = 1.0 \times 10^5 \text{ MN/m}^2$

$$= 1.0 \times 10^5 \times 10^6 \text{ N/m}^2 \quad (\because 1 \text{ MN} = 10^6 \text{ N})$$

$$= 10^{11} \text{ N/m}^2$$

Co-efficient of linear expansion,  $\alpha = 0.000012$

(i) The expansion of the rod due to temperature rise is given by equation (1.13).

$$\begin{aligned} \therefore \text{Expansion of the rod} &= \alpha \cdot T \cdot L \\ &= 0.000012 \times 70 \times 200 \\ &= 0.168 \text{ cm. Ans.} \end{aligned}$$

(ii) The stress in the material of the rod if expansion is prevented is given by equation (1.15).

$$\begin{aligned} \therefore \text{Thermal stress, } \sigma &= \alpha \cdot T \cdot E \\ &= 0.000012 \times 70 \times 1.0 \times 10^{11} \text{ N/m}^2 \\ &= 84 \times 10^6 \text{ N/m}^2 = 84 \text{ N/mm}^2. \text{ Ans. } (\because 10^6 \text{ N/m}^2 = 1 \text{ N/mm}^2) \end{aligned}$$

**Problem 1.29.** A steel rod of 3 cm diameter and 5 m long is connected to two grips and the rod is maintained at a temperature of  $95^\circ\text{C}$ . Determine the stress and pull exerted when the temperature falls to  $30^\circ\text{C}$ , if

(i) the ends do not yield, and

(ii) the ends yield by 0.12 cm.

Take  $E = 2 \times 10^5 \text{ MN/m}^2$  and  $\alpha = 12 \times 10^{-6}/^\circ\text{C}$ .

**Sol.** Given :

Dia. of the rod,  $d = 3 \text{ cm} = 30 \text{ mm}$

$$\therefore \text{Area of the rod, } A = \frac{\pi}{4} \times 30^2 = 225 \pi \text{ mm}^2$$

Length of the rod,  $L = 5 \text{ m} = 5000 \text{ mm}$

Initial temperature,  $T_1 = 95^\circ\text{C}$

Final temperature,  $T_2 = 30^\circ\text{C}$

$$\begin{aligned} \therefore \text{Fall in temperature, } T &= T_1 - T_2 = 95 - 30 = 65^\circ\text{C} \\ \text{Modulus of elasticity, } E &= 2 \times 10^5 \text{ MN/m}^2 \\ &= 2 \times 10^5 \times 10^6 \text{ N/m}^2 \\ &= 2 \times 10^{11} \text{ N/m}^2 \end{aligned}$$

$$\text{Co-efficient of linear expansion, } \alpha = 12 \times 10^{-6}/^\circ\text{C.}$$

(i) When the ends do not yield

The stress is given by equation (1.15).

$$\begin{aligned} \therefore \text{Stress} &= \alpha \cdot T \cdot E = 12 \times 10^{-6} \times 65 \times 2 \times 10^{11} \text{ N/m}^2 \\ &= 156 \times 10^6 \text{ N/m}^2 \text{ or } 156 \text{ N/mm}^2 \text{ (tensile). Ans.} \end{aligned}$$

Pull in the rod = Stress  $\times$  Area

$$= 156 \times 225 \pi = 110269.9 \text{ N. Ans.}$$

(ii) When the ends yield by 0.12 cm

$$\therefore \delta = 0.12 \text{ cm} = 1.2 \text{ mm}$$

The stress when the ends yield is given by equation (1.16).

$$\begin{aligned} \therefore \text{Stress} &= \frac{(\alpha \cdot T \cdot L - \delta)}{L} \times E \\ &= \frac{(12 \times 10^{-6} \times 65 \times 5000 - 1.2)}{5000} \times 2 \times 10^5 \text{ N/mm}^2 \\ &= \frac{(3.9 - 1.2)}{5000} \times 2 \times 10^5 = 108 \text{ N/mm}^2. \text{ Ans.} \end{aligned}$$

Pull in the rod = Stress  $\times$  Area

$$= 108 \times 225 \pi = 76340.7 \text{ N. Ans.}$$

### 1.15. THERMAL STRESSES IN COMPOSITE BARS

Fig. 1.24 (a) shows a composite bar consisting of two members, a bar of brass and another of steel. Let the composite bar be heated through some temperature. If the members are free to expand then no stresses will be induced in the members. But the two members are rigidly fixed and hence the composite bar as a whole will expand by the same amount. As the co-efficient of linear expansion of brass is more than that of the steel, the brass will expand more than the steel. Hence the free expansion of brass will be more than that of the steel. But both the members are not free to expand, and hence the expansion of the composite bar, as a whole, will be less than that of the brass, but more than that of the steel. Hence the stress

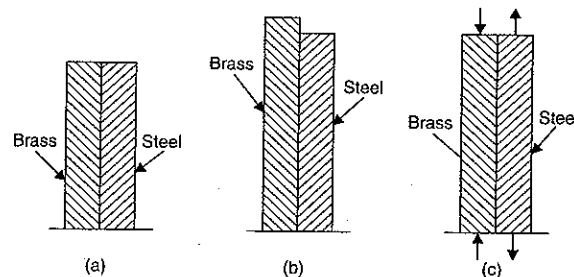

Fig. 1.24

induced in the brass will be compressive whereas the stress in steel will be tensile as shown in Fig. 1.24 (c). Hence the load or force on the brass will be compressive whereas on the steel the load will be tensile.

Let

$A_b$  = Area of cross-section of brass bar

$\sigma_b$  = Stress in brass

$e_b$  = Strain in brass

$\alpha_b$  = Co-efficient of linear expansion for brass

$E_b$  = Young's modulus for copper

$A_s, \sigma_s, e_s$  and  $\alpha_s$  = Corresponding values of area, stress, strain and co-efficient of linear expansion for steel, and

$E_s$  = Young's modulus for steel.

$\delta$  = Actual expansion of the composite bar

Now load on the brass = Stress in brass  $\times$  Area of brass

$$= \sigma_b \times A_b$$

And load on the steel =  $\sigma_s \times A_s$

For the equilibrium of the system, compression in copper should be equal to tension in the steel

or Load on the brass = Load on the steel

$$\therefore \sigma_b \times A_b = \sigma_s \times A_s.$$

Also we know that actual expansion of steel

= Actual expansion of brass

...(i)

But actual expansion of steel

= Free expansion of steel + Expansion due to tensile stress in steel

$$= \alpha_s \cdot T \cdot L + \frac{\sigma_s}{E_s} \cdot L$$

And actual expansion of copper

= Free expansion of copper - Contraction due to compressive stress induced in brass

$$= \alpha_b \cdot T \cdot L - \frac{\sigma_b}{E_b} \cdot L$$

Substituting these values in equation (i), we get

$$\alpha_s \times T \times L + \frac{\sigma_s}{E_s} \times L = \alpha_b \times T \times L - \frac{\sigma_b}{E_b} \times L$$

or

$$\alpha_s T + \frac{\sigma_s}{E_s} = \alpha_b \times T - \frac{\sigma_b}{E_b}$$

where  $T$  = Rise of temperature.

**Problem 1.30.** A steel rod of 20 mm diameter passes centrally through a copper tube of 50 mm external diameter and 40 mm internal diameter. The tube is closed at each end by rigid plates of negligible thickness. The nuts are tightened lightly home on the projecting parts of the

rod. If the temperature of the assembly is raised by  $50^\circ\text{C}$ , calculate the stresses developed in copper and steel. Take  $E$  for steel and copper as  $200 \text{ GN/m}^2$  and  $100 \text{ GN/m}^2$  and  $\alpha$  for steel and copper as  $12 \times 10^{-6} \text{ per } ^\circ\text{C}$  and  $18 \times 10^{-6} \text{ per } ^\circ\text{C}$ .

**Sol. Given :**

Dia. of steel rod = 20 mm

$\therefore$  Area of steel rod,  $A_s = \frac{\pi}{4} \times 20^2 = 100\pi \text{ mm}^2$

Area of copper tube,  $A_c = \frac{\pi}{4} (50^2 - 40^2) \text{ mm}^2 = 225\pi \text{ mm}^2$

Rise of temperature,  $T = 50^\circ\text{C}$

$E$  for steel,  $E_s = 200 \text{ GN/m}^2$

$$= 200 \times 10^9 \text{ N/m}^2$$

$$= 200 \times 10^3 \times 10^6 \text{ N/m}^2$$

$$= 200 \times 10^3 \text{ N/mm}^2$$

$$(\because 10^6 \text{ N/m}^2 = 1 \text{ N/mm}^2)$$

$E$  for copper,  $E_c = 100 \text{ GN/m}^2 = 100 \times 10^9 \text{ N/m}^2$

$$= 100 \times 10^3 \times 10^6 \text{ N/m}^2 = 100 \times 10^3 \text{ N/mm}^2$$

$\alpha$  for steel,  $\alpha_s = 12 \times 10^{-6} \text{ per } ^\circ\text{C}$

$\alpha$  for copper,  $\alpha_c = 18 \times 10^{-6} \text{ per } ^\circ\text{C}$ .

As  $\alpha$  for copper is more than that of steel, hence the free expansion of copper will be more than that of steel when there is a rise in temperature. But the ends of the rod and the tube is fixed to the rigid plates and the nuts are tightened on the projected parts of the rod. Hence the two members are not free to expand. Hence the tube and the rod will expand by the same amount. The free expansion of the copper tube will be more than the common expansion, whereas the free expansion of the steel rod will be less than the common expansion. Hence the copper tube will be subjected to compressive stress and the steel rod will be subjected to tensile stress.

Let  $\sigma_s =$  Tensile stress in steel

$\sigma_c =$  Compressive stress in copper.

For the equilibrium of the system,

Tensile load on steel = Compressive load on copper

$$\text{or } \sigma_s \cdot A_s = \sigma_c \cdot A_c$$

$$\text{or } \sigma_s = \frac{A_c}{A_s} \times \sigma_c$$

$$= \frac{225\pi}{100\pi} \times \sigma_c = 2.25\sigma_c \quad \dots(i)$$

We know that the copper tube and steel rod will actually expand by the same amount.

$\therefore$  Actual expansion of steel = Actual expansion of copper  $\dots(ii)$

But actual expansion of steel

= Free expansion of steel + Expansion due to tensile stress in steel

$$= \alpha_s \cdot T \cdot L + \frac{\sigma_s}{E_s} \cdot L$$

and actual expansion of copper

= Free expansion of copper - Contraction due to compressive stress in copper

$$= \alpha_c \cdot T \cdot L - \frac{\sigma_c}{E_c} \cdot L$$

Substituting these values in equation (ii), we get

$$\alpha_s \cdot T \cdot L + \frac{\sigma_s}{E_s} \cdot L = \alpha_c \cdot T \cdot L - \frac{\sigma_c}{E_c} \cdot L$$

$$\text{or } \alpha_s \cdot T + \frac{\sigma_s}{E_s} = \alpha_c \cdot T - \frac{\sigma_c}{E_c}$$

$$\text{or } 12 \times 10^{-6} \times 50 + \frac{2.25\sigma_c}{200 \times 10^3} = 18 \times 10^{-6} \times 50 - \frac{\sigma_c}{100 \times 10^3} \quad (\because \sigma_s = 2.25\sigma_c)$$

$$\text{or } \frac{2.25\sigma_c}{200 \times 10^3} + \frac{\sigma_c}{100 \times 10^3} = 18 \times 10^{-6} \times 50 - 12 \times 10^{-6} \times 50$$

$$\text{or } 1.125 \times 10^{-5} \sigma_c + 10^{-5} \sigma_c = 6 \times 10^{-6} \times 50$$

$$\text{or } 2.125 \times 10^{-5} \sigma_c = 30 \times 10^{-5}$$

$$\text{or } 2.125\sigma_c = 30$$

$$\therefore \sigma_c = \frac{30}{2.125} = 14.117 \text{ N/mm}^2. \text{ Ans.}$$

Substituting this value in equation (i), we get

$$\sigma_s = 14.117 \times 2.25 \\ = 31.76 \text{ N/mm}^2. \text{ Ans.}$$

**Problem 1.31.** A steel tube of 30 mm external diameter and 20 mm internal diameter encloses a copper rod of 15 mm diameter to which it is rigidly joined at each end. If, at a temperature of  $10^\circ\text{C}$  there is no longitudinal stress, calculate the stresses in the rod and tube when the temperature is raised to  $200^\circ\text{C}$ . Take  $E$  for steel and copper as  $2.1 \times 10^5 \text{ N/mm}^2$  and  $1 \times 10^5 \text{ N/mm}^2$  respectively. The value of co-efficient of linear expansion for steel and copper is given as  $11 \times 10^{-6} \text{ per } ^\circ\text{C}$  and  $18 \times 10^{-6} \text{ per } ^\circ\text{C}$  respectively.

**Sol. Given :**

Dia. of copper rod = 15 mm

$\therefore$  Area of copper rod,  $A_c = \frac{\pi}{4} \times 15^2 = 56.25\pi \text{ mm}^2$

Area of steel tube,  $A_s = \frac{\pi}{4} (30^2 - 20^2) = 125\pi \text{ mm}^2$

Rise of temperature,  $T = (200 - 10) = 190^\circ\text{C}$

$E$  for steel,  $E_s = 2.1 \times 10^5 \text{ N/mm}^2$

$E$  for copper,  $E_c = 1 \times 10^5 \text{ N/mm}^2$

Value of  $\alpha$  for steel,  $\alpha_s = 11 \times 10^{-6} \text{ per } ^\circ\text{C}$

Value of  $\alpha$  for copper,  $\alpha_c = 18 \times 10^{-6} \text{ per } ^\circ\text{C}$

As the value of  $\alpha$  for copper is more than that of steel, hence the copper rod would expand more than the steel tube if it were free. Since the two are joined together, the copper

will be prevented from expanding its full amount and will be put in compression, the steel being put in tension.

Let  $\sigma_s$  = Stress in steel  
 $\sigma_c$  = Stress in copper.

For equilibrium of the system,

Compressive load on copper = Tensile load on steel

$$\sigma_c \cdot A_c = \sigma_s \cdot A_s$$

$$\therefore \sigma_c = \sigma_s \cdot \frac{A_s}{A_c} = \sigma_s \cdot \frac{125\pi}{56.25\pi} = 2.22 \times \sigma_s \quad \dots(i)$$

We know that the copper rod and the steel tube will actually expand by the same amount.

Now actual expansion of steel = Free expansion of steel + Expansion due to tensile stress

$$= \alpha_s \cdot T \cdot L + \frac{\sigma_s}{E_s} \cdot L$$

and actual expansion of copper = Free expansion of copper

- Contraction due to compressive stress

$$= \alpha_c \cdot T \cdot L - \frac{\sigma_c}{E_c} \cdot L$$

But actual expansion of steel = Actual expansion of copper

$$\alpha_s \cdot T \cdot L + \frac{\sigma_s}{E_s} \cdot L = \alpha_c \cdot T \cdot L - \frac{\sigma_c}{E_c} \cdot L$$

$$\text{or} \quad \alpha_s \cdot T + \frac{\sigma_s}{E_s} = \alpha_c \cdot T - \frac{\sigma_c}{E_c}$$

$$\text{or} \quad 11 \times 10^{-6} \times 190 + \frac{\sigma_s}{2.1 \times 10^5} = 18 \times 10^{-6} \times 190 - \frac{2.22 \sigma_s}{1 \times 10^5} \quad (\because \sigma_c = 2.22 \sigma_s)$$

$$\text{or} \quad \frac{\sigma_s}{2.1 \times 10^5} + \frac{2.22 \sigma_s}{1 \times 10^5} = 18 \times 10^{-6} \times 190 - 11 \times 10^{-6} \times 190$$

$$\text{or} \quad \frac{\sigma_s + 2.1 \times 2.22 \sigma_s}{2.1 \times 10^5} = 5 \times 10^{-6} \times 190$$

$$\text{or} \quad \sigma_s + 4.662 \sigma_s = 5 \times 10^{-6} \times 190 \times 2.1 \times 10^5$$

$$\text{or} \quad 5.662 \sigma_s = 199.5$$

$$\therefore \sigma_s = \frac{199.5}{5.662} = 35.235 \text{ N/mm}^2. \text{ Ans.}$$

Substituting this value in equation (i), we get

$$\sigma_c = 2.22 \times 35.235 = 78.22 \text{ N/mm}^2. \text{ Ans.}$$

**Problem 1.32.** A steel tube of 30 mm external diameter and 25 mm internal diameter encloses a gun metal rod of 20 mm diameter to which it is rigidly joined at each end. The temperature of the whole assembly is raised to 140°C and the nuts on the rod are then screwed lightly home on the ends of the tube. Find the intensity of stress in the rod when the common temperature has fallen to 30°C. The value of  $E$  for steel and gun metal is  $2.1 \times 10^5 \text{ N/mm}^2$  and

$1 \times 10^5 \text{ N/mm}^2$  respectively. The linear co-efficient of expansion for steel and gun metal is  $12 \times 10^{-6} \text{ per } ^\circ\text{C}$  and  $20 \times 10^{-6} \text{ per } ^\circ\text{C}$ .

Sol. Given :

Dia. of gun metal rod = 20 mm

$$\therefore \text{Area of gun metal rod, } A_g = \frac{\pi}{4} \times 20^2 = 100\pi \text{ mm}^2$$

$$\text{Area of steel tube, } A_s = \frac{\pi}{4} (30^2 - 25^2) = 68.75\pi \text{ mm}^2$$

Fall in temperature,  $T = 140 - 30 = 110$

Value of  $E$  for steel,  $E_s = 2.1 \times 10^5 \text{ N/mm}^2$

Value of  $E$  for gun metal,  $E_g = 1 \times 10^5 \text{ N/mm}^2$

Value of  $\alpha$  for steel,  $\alpha_s = 12 \times 10^{-6} \text{ per } ^\circ\text{C}$

Value of  $\alpha$  for gun metal,  $\alpha_g = 20 \times 10^{-6} \text{ per } ^\circ\text{C}$ .

As  $\alpha_g$  is greater than  $\alpha_s$ , hence the free contraction of the gun metal rod will be more than that of steel when there is a fall in temperature. But, since the ends of the rods have been provided with nuts, the two members are not free to contract fully, each of the member will contract by the same amount. The free contraction of the gun metal rod will be greater than the common contraction, whereas the free contraction of the steel tube will be less than the common contraction. Hence the steel tube will be subjected to compressive stress while the gun metal rod will be subjected to tensile stress.

Let  $\sigma_s$  = Stress in steel tube and

$\sigma_g$  = Stress in gun metal rod.

For the equilibrium of the system,

Total compressive force in steel = Total tensile force in gun metal

$$\therefore \sigma_s \cdot A_s = \sigma_g \cdot A_g$$

$$\text{or} \quad \sigma_s = \sigma_g \cdot \frac{A_g}{A_s} = \sigma_g \cdot \frac{100\pi}{68.75\pi}$$

$$\text{or} \quad \sigma_s = 1.4545 \sigma_g \quad \dots(i)$$

We also know that the steel tube and gun metal rod will actually contract by the same amount.

$\therefore$  Actual contraction of steel = Actual contraction of gun metal rod

But actual contraction of steel = Free contraction of steel

+ contraction due to compressive stress in steel

$$= \alpha_s \cdot T \cdot L + \frac{\sigma_s}{E_s} \cdot L$$

Actual contraction of gun metal = Free contraction of gun metal

- expansion due to tensile stress in gun metal

$$= \alpha_g \cdot T \cdot L - \frac{\sigma_g}{E_g} \cdot L$$



Equating the two values, we get

$$\alpha_s \cdot T \cdot L + \frac{\sigma_g}{E_s} \cdot L = \alpha_g \cdot T \cdot L - \frac{\sigma_g}{E_g} \cdot L$$

$$\text{or } \alpha_s \cdot T + \frac{\sigma_g}{E_s} = \alpha_g \cdot T - \frac{\sigma_g}{E_g}$$

$$\text{or } 12 \times 10^{-6} \times 110 + \frac{1.4545 \sigma_g}{2.1 \times 10^5} = 20 \times 10^{-6} \times 110 - \frac{\sigma_g}{1 \times 10^5} \quad (\because \sigma_g = 1.4545 \sigma_g)$$

$$\text{or } \frac{1.4545}{2.1 \times 10^5} \sigma_g + \frac{\sigma_g}{1 \times 10^5} = 20 \times 10^{-6} \times 110 - 12 \times 10^{-6} \times 110$$

$$\text{or } \frac{1.4545 \sigma_g + 2.1 \times \sigma_g}{2.1 \times 10^5} = 8 \times 10^{-6} \times 110$$

$$\text{or } 3.5545 \sigma_g = 8 \times 10^{-6} \times 110 \times 2.1 \times 10^5 = 184.8$$

$$\therefore \sigma_g = \frac{184.8}{3.5545} = 51.99 \text{ N/mm}^2. \text{ Ans.}$$

Substituting this value in equation (i), we get

$$\sigma_s = 1.4545 \times 51.99 = 75.62 \text{ N/mm}^2. \text{ Ans.}$$

### 1.16. ELONGATION OF A BAR DUE TO ITS OWN WEIGHT

Fig. 1.25 shows a bar AB fixed at end A and hanging freely under its own weight.

Let  $L$  = Length of bar,  
 $A$  = Area of cross-section,  
 $E$  = Young's modulus for the bar material,  
 $w$  = Weight per unit volume of the bar material.

Consider a small strip of thickness  $dx$  at a distance  $x$  from the lower end.

Weight of the bar for a length of  $x$  is given by,

$$P = \text{Specific weight} \times \text{Volume of bar upto length } x \\ = w \times A \times x$$

This means that on the strip, a weight of  $w \times A \times x$  is acting in the downward direction. Due to this weight, there will be some increase in the length of element. But length of the element is  $dx$ .

Now stress on the element

$$= \frac{\text{Weight acting on element}}{\text{Area of cross-section}} = \frac{w \times A \times x}{A} = w \times x$$

The above equation shows that stress due to self weight in a bar is not uniform. It depends on  $x$ . The stress increases with the increase of  $x$ .

$$\text{Strain in the element} = \frac{\text{Stress}}{E} = \frac{w \times x}{E}$$

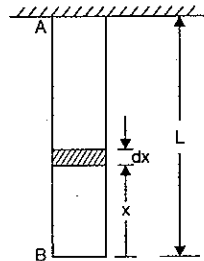

Fig. 1.25

$\therefore$  Elongation of the element

$$= \text{Strain} \times \text{Length of element} \\ = \frac{w \times x}{E} \times dx$$

Total elongation of the bar is obtained by integrating the above equation between limits zero and  $L$ .

$$\delta L = \int_0^L \frac{w \times x}{E} dx = \frac{w}{E} \int_0^L x \cdot dx$$

$$= \frac{w}{E} \left[ \frac{x^2}{2} \right]_0^L = \frac{w}{E} \times \frac{L^2}{2} \quad \dots(1.17)$$

$$= \frac{WL}{2E} \quad (\because W = w \times L) \quad \dots(1.18)$$

### 1.17. ANALYSIS OF BAR OF UNIFORM STRENGTH

In the previous article we have seen that the stress due to self weight of the bar is not constant but the stress increases with the increase of distance from the lower end. If the self weight is neglected and a bar of uniform section is subjected to an axial load, then the stress in the bar would be uniform.

Let us find the shape of the bar of which self weight of the bar is considered and having uniform stress on all sections when subjected to an axial  $P$ . Such bar is shown in Fig. 1.26 in which the area of the bar increases from the lower end to the upper end.

Let  $A_1$  = Area of upper end,  
 $A_2$  = Area of lower end,  
 $w$  = Weight per unit volume of the bar,  
 $\sigma$  = Uniform stress on the bar.

Consider a strip of length  $dx$  at a distance  $x$  from the lower end. Let  $A$  be the area of the strip at section  $AB$  and  $(A + dA)$  be the area at section  $DC$ . Consider the equilibrium of the strip  $ABCD$ .

The forces acting on the strip are :

(i) Weight of strip acting downward and equal to  $w \times \text{volume of strip i.e., } w \times A \times dx$ .

(ii) Force on section  $AB$  due to uniform stress ( $\sigma$ ) and is equal to  $\sigma \times A$ . This is acting downward.

(iii) Force on section  $CD$  due to uniform stress ( $\sigma$ ) and is equal to  $\sigma(A + dA)$ . This is acting upwards.

Now, Total force acting upwards

$$= \text{Total force acting downwards}$$

$$\text{or } \sigma(A + dA) = \sigma \times A + wAdx$$

$$\text{or } \sigma \times A + \sigma dA = \sigma \times A + wAdx$$

$$\text{or } \sigma dA = wAdx$$

$$\text{or } \frac{dA}{A} = \frac{w}{\sigma} dx$$

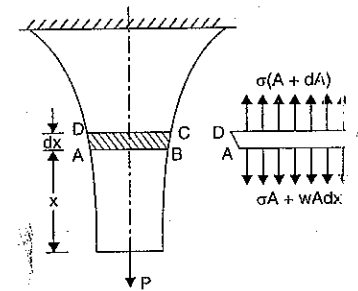

Fig. 1.26

Integrating the above equation, we get

$$\int \frac{dA}{A} = \int \frac{w}{\sigma} dx \quad \text{or} \quad \log_e A = \frac{w}{\sigma} x + C \quad \dots(ii)$$

where  $C$  is the constant of integration.

$$\text{At } x = 0, \quad A = A_2$$

Substituting these values in equation (i), we get

$$\log_e A_2 = \frac{w}{\sigma} \times 0 + C$$

$$\therefore C = \log_e A_2$$

Substituting the value of  $C$  in equation (i), we get

$$\log_e A = \frac{w}{\sigma} x + \log_e A_2$$

$$\text{or} \quad \log_e A - \log_e A_2 = \frac{w}{\sigma} x \quad \text{or} \quad \log_e \left( \frac{A}{A_2} \right) = \frac{w}{\sigma} x$$

$$\text{or} \quad \frac{A}{A_2} = e^{\frac{wx}{\sigma}} \quad \text{or} \quad A = A_2 e^{\frac{wx}{\sigma}} \quad \dots(ii)$$

The above equation gives the area at a distance  $x$  from lower end.

$$\text{At } x = L, \quad A = A_1$$

Substituting these values in equation (ii), we get

$$A_1 = A_2 e^{\frac{wL}{\sigma}} \quad \dots(1.19)$$

**Problem 1.33.** A vertical bar fixed at the upper end and of uniform strength carries an axial tensile load of 600 kN. The bar is 20 m long and having weight per unit volume as 0.00008 N/mm<sup>3</sup>. If the area of the bar at the lower end is 400 mm<sup>2</sup>, find the area of the bar at the upper end.

**Sol.** Given :

$$\text{Axial load, } P = 600 \text{ kN} = 600 \times 10^3 \text{ N}$$

$$\text{Length, } L = 20 \text{ m} = 20 \times 10^3 \text{ mm}$$

$$\text{Weight per unit volume, } w = 0.00008 \text{ N/mm}^3$$

$$\text{Area of bar at lower end, } A_2 = 400 \text{ mm}^2$$

$$\text{Let } A_1 = \text{Area of bar at upper end.}$$

Now the uniform stress\* on the bar,

$$\sigma = \frac{P}{A_2} = \frac{600 \times 10^3}{400} = 1500 \text{ N/mm}^2$$

Using equation (1.19), we get

$$\begin{aligned} A_1 &= A_2 e^{\frac{wL}{\sigma}} \\ &= 400 \times e^{\frac{0.00008 \times 20 \times 10^3}{1500}} = 400 \times e^{0.0010667} \end{aligned}$$

\*The stress on lower end =  $\frac{P}{A_2}$ . We want that the stress in the bar should be uniform i.e.,

$$\text{equal to } \frac{P}{A_2}$$

$$\text{or} \quad \frac{A_1}{400} = e^{0.0010667}$$

$$\text{or} \quad \log_e \frac{A_1}{400} = 0.0010667$$

$$\text{or} \quad 2.3 \log_{10} \frac{A_1}{400} = 0.0010667$$

$$\text{or} \quad \log_{10} \frac{A_1}{400} = \frac{0.0010667}{2.3} = 0.00046378$$

$$\therefore \frac{A_1}{400} = \text{Antilog of } 0.00046378 = 1.00107$$

$$\therefore A_1 = 400 \times 1.00107 = 400.428 \text{ mm}^2. \quad \text{Ans.}$$

### HIGHLIGHTS

1. The resistance per unit area, offered by a body against deformation is known as stress. The stress is given by

$$\sigma = \frac{P}{A}$$

where  $P$  = External force or load ;  $A$  = Cross-sectional area.

2. Stress is expressed as kgf/m<sup>2</sup>, kgf/cm<sup>2</sup>, N/m<sup>2</sup> and N/mm<sup>2</sup>.
3. 1 N/m<sup>2</sup> = 10<sup>-4</sup> N/cm<sup>2</sup> or 10<sup>-6</sup> N/mm<sup>2</sup>.
4. The ratio of change of dimension of the body to the original dimension is known as strain.
5. The stress induced in a body, which is subjected to two equal and opposite pulls, is known as tensile stress.
6. The stress induced in a body, which is subjected to two equal and opposite pushes, is known as compressive stress.
7. Elasticity is the property by virtue of which certain materials return back to their original position after the removal of the external force.
8. Hooke's law states that within elastic limit, the stress is proportional to the strain.
9. The ratio of tensile stress (or compressive stress) to the corresponding strain is known as Young's modulus or modulus of elasticity and is denoted by  $E$ .

$$E = \frac{\text{Tensile or compressive stress}}{\text{Corresponding strain}}$$

10. The ratio of shear stress to the corresponding shear strain within the elastic limit, is known as modulus of rigidity or shear modulus. It is denoted by  $C$  (or  $G$  or  $N$ ).
11. Total change in the length of a bar of different lengths and of different diameters when subjected to an axial load  $P$ , is given by

$$dL = \frac{P}{E} \left[ \frac{L_1}{A_1} + \frac{L_2}{A_2} + \frac{L_3}{A_3} + \dots \right] \quad \dots \text{when } E \text{ is same}$$

$$= P \left[ \frac{L_1}{E_1 A_1} + \frac{L_2}{E_2 A_2} + \frac{L_3}{E_3 A_3} + \dots \right] \quad \dots \text{when } E \text{ is different.}$$

12. The total extension of a uniformly tapering circular rod of diameters  $D_1$  and  $D_2$ , when the rod is subjected to an axial load  $P$  is given by

$$dL = \frac{4PL}{\pi ED_1 D_2} \quad \text{where } L = \text{Total length of the rod.}$$

13. A composite bar is made up of two or more bars of equal lengths but of different materials rigidly fixed with each other and behaving as one unit for extension or compression.
14. In case of a composite bar having equal length : (i) strain in each bar is equal and (ii) total load on the composite bar is equal to the sum of loads carried by each different materials.
15. The stresses induced in a body due to change in temperature are known as thermal stresses.
16. Thermal strain and thermal stress is given by  
thermal strain,  $e = \alpha.T$  and thermal stress,  $p = \alpha.T.E$   
where  $\alpha$  = Co-efficient of linear expansion ,  
 $T$  = Rise or fall of temperature,  
 $E$  = Young's modulus.
17. Total elongation of a uniformly tapering rectangular bar when subjected to an axial load  $P$  is given by

$$dL = \frac{PL}{Et(a-b)} \log_e \frac{a}{b}$$

where  $L$  = Total length of bar ;  $t$  = Thickness of bar  
 $a$  = Width at bigger end ;  $b$  = Width at smaller end  
 $E$  = Young's modulus.

18. In case of a composite bar having two or more bars of different lengths, the extension or compression in each bar will be equal. And the total load will be equal to the sum of the loads carried by each member.
19. In case of nut and bolt used on a tube with washers, the tensile load on the bolt is equal to the compressive load on the tube.
20. Elongation of a bar due to its own weight is given by

$$\delta L = \frac{w}{E} \times \frac{L^2}{2} \text{ or } \frac{WL}{2E}$$

where  $w$  = Weight per unit volume of the bar material  
 $L$  = Length of bar.

### EXERCISE 1

#### (A) Theoretical Questions

- Define stress and strain. Write down the S.I. and M.K.S. units of stress and strain.
- Explain clearly the different types of stresses and strains.
- Define the terms : Elasticity, elastic limit, Young's modulus and modulus of rigidity.
- State Hooke's law.
- Three sections of a bar are having different lengths and different diameters. The bar is subjected to an axial load  $P$ . Determine the total change in length of the bar. Take Young's modulus of different sections same.
- Distinguish between the following, giving due explanation :
  - Stress and strain,
  - Force and stress, and
  - Tensile stress and compressive stress.

7. Prove that the total extension of a uniformly tapering rod of diameters  $D_1$  and  $D_2$ , when the rod is subjected to an axial load  $P$  is given by

$$dL = \frac{4PL}{\pi ED_1 D_2}$$

where  $L$  = Total length of the rod.

8. Define a composite bar. How will you find the stresses and load carried by each member of a composite bar ?
9. Define modular ratio, thermal stresses, thermal strains and Poisson's ratio.
10. A rod whose ends are fixed to rigid supports, is heated so that rise in temperature is  $T^\circ\text{C}$ . Prove that the thermal strain and thermal stresses set up in the rod are given by,  
Thermal strain =  $\alpha.T$  and  
Thermal stress =  $\alpha.T.E$   
where  $\alpha$  = Co-efficient of linear expansion.
11. What is the procedure of finding thermal stresses in a composite bar ?
12. What do you mean by 'a bar of uniform strength' ?
13. Find an expression for the total elongation of a bar due to its own weight, when the bar is fixed at its upper end and hanging freely at the lower end.
14. Find an expression for the total elongation of a uniformly tapering rectangular bar when it is subjected to an axial load  $P$ .

#### (B) Numerical Problems

- A rod 200 cm long and of diameter 3.0 cm is subjected to an axial pull of 30 kN. If the Young's modulus of the material of the rod is  $2 \times 10^5 \text{ N/mm}^2$ , determine : (i) stress, (ii) strain and (iii) the elongation of the rod. [Ans. (i) 42.44 N/mm<sup>2</sup> (ii) 0.000212 (iii) 0.0424 cm]
- Find the Young's modulus of a rod of diameter 30 mm and of length 300 mm which is subjected to a tensile load of 60 kN and the extension of the rod is equal to 0.4 mm. [Ans. 63.6 GN/m<sup>2</sup>]
- The safe stress, for a hollow steel column which carries an axial load of  $2.2 \times 10^3 \text{ kN}$  is 120 MN/m<sup>2</sup>. If the external diameter of the column is 25 cm, determine the internal diameter. [Ans. 19.79 cm]
- An axial pull of 40000 N is acting on a bar consisting of three sections of length 30 cm, 25 cm and 20 cm and of diameters 2 cm, 4 cm and 5 cm respectively. If the Young's modulus =  $2 \times 10^5 \text{ N/mm}^2$ , determine :
  - stress in each section and
  - total extension of the bar. [Ans. (i) 127.32, 31.8, 20.37 N/mm<sup>2</sup>, (ii) 0.025 cm]
- The ultimate stress for a hollow steel column which carries an axial load of 2 MN is 500 N/mm<sup>2</sup>. If the external diameter of the column is 250 mm, determine the internal diameter. Take the factor of safety as 4.0. [Ans. - 205.25 mm]
- A member formed by connecting a steel bar to an aluminium bar is shown in Fig. 1.27. Assuming that the bars are prevented from buckling sideways, calculate the magnitude of force  $P$ , that will cause the total length of the member to decrease 0.30 mm. The values of elastic modulus for steel and aluminium are  $2 \times 10^5 \text{ N/mm}^2$  and  $6.5 \times 10^4 \text{ N/mm}^2$  respectively. [Ans. 406.22 kN]

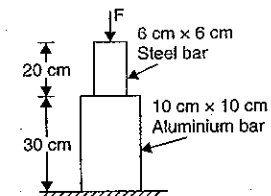

Fig. 1.27

7. The bar shown in Fig. 1.28 is subjected to a tensile load of 150 kN. If the stress in the middle portion is limited to  $160 \text{ N/mm}^2$ , determine the diameter of the middle portion. Find also the length of the middle portion if the total elongation of the bar is to be  $0.25 \text{ cm}$ . Young's modulus is given as equal to  $2.0 \times 10^5 \text{ N/mm}^2$ . [Ans. 3.45 cm, 29.38 cm]

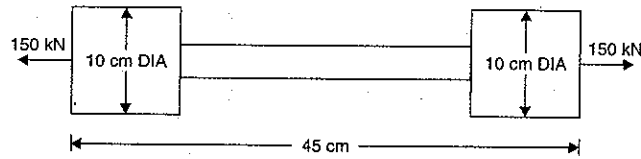

Fig. 1.28

8. A brass bar, having cross-section area of  $900 \text{ mm}^2$ , is subjected to axial forces as shown in Fig. 1.29 in which  $AB = 0.6 \text{ m}$ ,  $BC = 0.8 \text{ m}$  and  $CD = 1.0 \text{ m}$ .

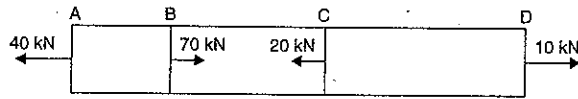

Fig. 1.29

Find the total elongation of the bar. Take  $E = 1 \times 10^5 \text{ N/mm}^2$ .

[Ans.  $-0.111 \text{ mm}$ ]

9. A member ABCD is subjected to point loads  $P_1, P_2, P_3$  and  $P_4$  as shown in Fig. 1.30. Calculate the force  $P_3$  necessary for equilibrium if  $P_1 = 120 \text{ kN}$ ,  $P_2 = 220 \text{ kN}$  and  $P_4 = 160 \text{ kN}$ . Determine also the net change in the length of the member. Take  $E = 200 \text{ GN/m}^2$ . [Ans. 0.55 mm]

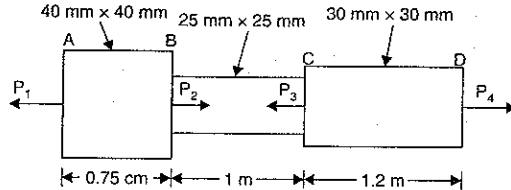

Fig. 1.30

10. A rod, which tapers uniformly from 5 cm diameter to 3 cm diameter in a length of 50 cm, is subjected to an axial load of 6000 N. If  $E = 2 \times 10^5 \text{ N/mm}^2$ , find the extension of the rod. [Ans. 0.00127 cm]
11. Find the modulus of elasticity for a rod, which tapers uniformly from 40 mm to 25 mm diameter in a length of 400 mm. The rod is subjected to a load of 6 kN and extension of the rod is 0.04 mm. [Ans. 76.39 kN/mm<sup>2</sup>]
12. A rectangular bar made of steel is 3 m long and 10 mm thick. The rod is subjected to an axial tensile load of 50 kN. The width of the rod varies from 70 mm at one end to 28 mm at the other. Find the extension of the rod if  $E = 2 \times 10^5 \text{ N/mm}^2$ . [Ans. 1.636 mm]
13. The extension in a rectangular steel bar of length 800 mm and of thickness 20 mm, is found to be 0.21 mm. The bar tapers uniformly in width from 80 mm to 40 mm. If  $E$  for the bar is  $2 \times 10^5 \text{ N/mm}^2$ , determine the axial tensile load on the bar. [Ans. 60.6 kN]

14. A steel rod of 2 cm diameter is enclosed centrally in a hollow copper tube of external diameter 4 cm and internal diameter of 3.5 cm. The composite bar is then subjected to an axial pull of 50000 N. If the length of each bar is equal to 20 cm, determine :  
(i) the stress in the rod and tube, and  
(ii) load carried by each bar.

Take  $E$  for steel =  $2 \times 10^5 \text{ N/mm}^2$  and for copper =  $1 \times 10^5 \text{ N/mm}^2$ .

[Ans. (i) 54.18 ; 108.36 N/mm<sup>2</sup> (ii) 34043.4 N and 15956.6 N]

15. A mild steel rod of 20 mm diameter and 300 mm long is enclosed centrally inside a hollow copper tube of external diameter 30 mm and internal diameter of 25 mm. The ends of the tube and rods are brazed together, and the composite bar is subjected to an axial pull of 40 kN. If  $E$  for steel and copper is  $200 \text{ GN/m}^2$  and  $100 \text{ GN/m}^2$  respectively, find the stresses developed in the rod and tube. Also find the extension of the rod. [Ans. 94.76 N/mm<sup>2</sup>, 47.38 N/mm<sup>2</sup> and 0.142 mm]
16. A load of 1.9 MN is applied on a short concrete column 300 mm  $\times$  200 mm. The column is reinforced with four steel bars of 10 mm diameter, one in each corner. Find the stresses in the concrete and steel bars. Take  $E$  for steel as  $2.1 \times 10^5 \text{ N/mm}^2$  and for concrete as  $1.4 \times 10^4 \text{ N/mm}^2$ . [Ans. 20.13, 301.9 N/mm<sup>2</sup>]

17. A reinforced short concrete column 250 mm  $\times$  250 mm in section is reinforced with 8 steel bars. The total area of steel bars is  $1608.50 \text{ mm}^2$ . The column carries a load of 270 kN. If the modulus of elasticity for steel is 18 times that of concrete, find the stresses in concrete and steel. If the stress in concrete shall not exceed  $4 \text{ N/mm}^2$ , find the area of steel required so that the column may support a load of 400 kN. [Ans.  $\sigma_c = 3 \text{ N/mm}^2$ ,  $\sigma_s = 54 \text{ N/mm}^2$  and  $A_s = 2206 \text{ mm}^2$ ]

18. Two vertical rods one of steel and other of copper are each rigidly fixed at the top and 60 cm apart. Diameters and length of each rod are 3 cm and 3.5 cm respectively. A cross bar fixed to the rods at the lower ends carries a load of 6000 N such that the cross bar remains horizontal even after loading. Find the stress in each rod and the position of the load on the bar. Take  $E$  for steel =  $2 \times 10^5 \text{ N/mm}^2$  and for copper =  $1 \times 10^5 \text{ N/mm}^2$ .

[Ans. 2.829 and 5.658 N/mm<sup>2</sup> ; 39.99 cm]

19. A steel rod of cross-sectional area  $1600 \text{ mm}^2$  and two brass rods each of cross-sectional (area of  $1000 \text{ mm}^2$  together support a load of 50 kN as shown in Fig. 1.31. Find the stresses in the rods. Take  $E$  for steel =  $2 \times 10^5 \text{ N/mm}^2$  and  $E$  for brass =  $1 \times 10^5 \text{ N/mm}^2$ .

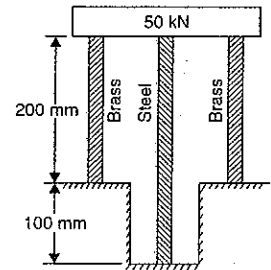

Fig. 1.31

[Ans.  $\sigma_s = 12.1 \text{ N/mm}^2$  and  $\sigma_b = 16.12 \text{ N/mm}^2$ ]

20. A rod is 3 m long at a temperature of  $15^\circ\text{C}$ . Find the expansion of the rod, when the temperature is raised to  $95^\circ\text{C}$ . If this expansion is prevented, find the stress induced in the material of the rod. Take  $E = 1 \times 10^5 \text{ N/mm}^2$  and  $\alpha = 0.000012$  per degree centigrade. [Ans. 0.288 cm, 96 N/mm<sup>2</sup>]
21. A steel rod 5 cm diameter and 6 m long is connected to two grips and the rod is maintained at a temperature of  $100^\circ\text{C}$ . Determine the stress and pull exerted when the temperature falls to  $20^\circ\text{C}$  if (i) the ends do not yield, and (ii) the ends yield by 0.15 cm. Take  $E = 2 \times 10^5 \text{ N/mm}^2$  and  $\alpha = 12 \times 10^{-6}/^\circ\text{C}$ . [Ans. (i) 192 N/mm<sup>2</sup> and 376990 N (ii) 142 N/mm<sup>2</sup>, 278816.3 N]
22. A steel rod of 20 mm diameter passes centrally through a copper tube 40 mm external diameter and 30 mm internal diameter. The tube is closed at each end by rigid plates of negligible thickness.

The nuts are tightened lightly home on the projected parts of the rod. If the temperature of the assembly is raised by  $60^{\circ}\text{C}$ , calculate the stresses developed in copper and steel. Take  $E$  for steel and copper as  $200 \text{ GN/m}^2$  and  $100 \text{ GN/m}^2$  and  $\alpha$  for steel and copper as  $12 \times 10^{-6}$  per  $^{\circ}\text{C}$  and  $18 \times 10^{-6}$  per  $^{\circ}\text{C}$ . [Ans. 16.23, 28.4  $\text{N/mm}^2$ ]

23. A vertical bar fixed at the upper end and of uniform strength carries an axial tensile load of 500 kN. The bar is 18 m long and having weight per unit volume as  $0.00008 \text{ N/mm}^3$ . If the area of the bar at the lower end is  $500 \text{ mm}^2$ , find the area of the bar at the upper end. [Ans.  $500.72 \text{ mm}^2$ ]
24. A straight circular rod tapering from diameter ' $D$ ' at one end to a diameter ' $d$ ' at the other end is subjected to an axial load ' $P$ '. Obtain an expression for the elongation of the rod.

$$\left[ \text{Ans. } \delta L = \frac{4PL}{\pi E \cdot D \cdot d} \right]$$

# 2

## Elastic Constants

### 2.1. INTRODUCTION

When a body is subjected to an axial tensile load, there is an increase in the length of the body. But at the same time there is a decrease in other dimensions of the body at right angles to the line of action of the applied load. Thus the body is having axial deformation and also deformation at right angles to the line of action of the applied load (*i.e.*, lateral deformation). This chapter deals with these deformations, Poisson's ratio, volumetric strains, bulk modulus, relation between Young's modulus and modulus of rigidity and relation between Young's modulus and bulk modulus.

### 2.2. LONGITUDINAL STRAIN

When a body is subjected to an axial tensile or compressive load, there is an axial deformation in the length of the body. The ratio of axial deformation to the original length of the body is known as longitudinal (or linear) strain. The longitudinal strain is also defined as the deformation of the body per unit length in the direction of the applied load.

Let  $L$  = Length of the body,  
 $P$  = Tensile force acting on the body,  
 $\delta L$  = Increase in the length of the body in the direction of  $P$ .

Then, longitudinal strain =  $\frac{\delta L}{L}$ .

### 2.3. LATERAL STRAIN

The strain at right angles to the direction of applied load is known as lateral strain. Let a rectangular bar of length  $L$ , breadth  $b$  and depth  $d$  is subjected to an axial tensile load  $P$  as shown in Fig. 2.1. The length of the bar will increase while the breadth and depth will decrease.

Let  $\delta L$  = Increase in length,  
 $\delta b$  = Decrease in breadth, and  
 $\delta d$  = Decrease in depth.

Then longitudinal strain =  $\frac{\delta L}{L}$  ... (2.1)

and lateral strain =  $\frac{\delta b}{b}$  or  $\frac{\delta d}{d}$  ... (2.2)

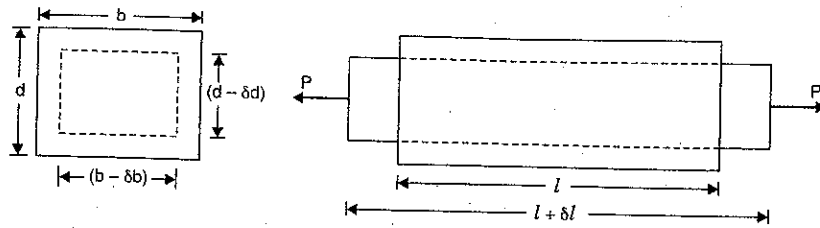

Fig. 2.1

Note. (i) If longitudinal strain is tensile, the lateral strains will be compressive.

(ii) If longitudinal strain is compressive then lateral strains will be tensile.

(iii) Hence every longitudinal strain in the direction of load is accompanied by lateral strains of the opposite kind in all directions perpendicular to the load.

## 2.4. POISSON'S RATIO

The ratio of lateral strain to the longitudinal strain is a constant for a given material, when the material is stressed within the elastic limit. This ratio is called **Poisson's ratio** and it is generally denoted by  $\mu$ . Hence mathematically,

$$\text{Poisson's ratio, } \mu = \frac{\text{Lateral strain}}{\text{Longitudinal strain}} \quad \dots(2.3)$$

or

$$\text{Lateral strain} = \mu \times \text{longitudinal strain}$$

As lateral strain is opposite in sign to longitudinal strain, hence algebraically, the lateral strain is written as

$$\text{Lateral strain} = -\mu \times \text{longitudinal strain} \quad \dots[2.3 (A)]$$

The value of Poisson's ratio varies from 0.25 to 0.33. For rubber, its value ranges from 0.45 to 0.50.

**Problem 2.1.** Determine the changes in length, breadth and thickness of a steel bar which is 4 m long, 30 mm wide and 20 mm thick and is subjected to an axial pull of 30 kN in the direction of its length. Take  $E = 2 \times 10^5 \text{ N/mm}^2$  and Poisson's ratio = 0.3.

Sol. Given :

Length of the bar,  $L = 4 \text{ m} = 4000 \text{ mm}$

Breadth of the bar,  $b = 30 \text{ mm}$

Thickness of the bar,  $t = 20 \text{ mm}$

$\therefore$  Area of cross-section,  $A = b \times t = 30 \times 20 = 600 \text{ mm}^2$

Axial pull,  $P = 30 \text{ kN} = 30000 \text{ N}$

Young's modulus,  $E = 2 \times 10^5 \text{ N/mm}^2$

Poisson's ratio,  $\mu = 0.3$ .

Now strain in the direction of load (or longitudinal strain),

$$\begin{aligned} &= \frac{\text{Stress}}{E} = \frac{\text{Load}}{\text{Area} \times E} & \left( \because \text{Stress} = \frac{\text{Load}}{\text{Area}} \right) \\ &= \frac{P}{A \cdot E} = \frac{30000}{600 \times 2 \times 10^5} = 0.00025. \end{aligned}$$

$$\text{But longitudinal strain} = \frac{\delta L}{L}$$

$$\therefore \frac{\delta L}{L} = 0.00025.$$

$$\begin{aligned} \therefore \delta L \text{ (or change in length)} &= 0.00025 \times L \\ &= 0.00025 \times 4000 = 1.0 \text{ mm. Ans.} \end{aligned}$$

Using equation (2.3),

$$\text{Poisson's ratio} = \frac{\text{Lateral strain}}{\text{Longitudinal strain}}$$

or

$$0.3 = \frac{\text{Lateral strain}}{0.00025}$$

$$\therefore \text{Lateral strain} = 0.3 \times 0.00025 = 0.000075.$$

We know that

$$\text{Lateral strain} = \frac{\delta b}{b} \text{ or } \frac{\delta d}{d} \left( \text{or } \frac{\delta t}{t} \right)$$

$$\begin{aligned} \therefore \delta b &= b \times \text{Lateral strain} \\ &= 30 \times 0.000075 = 0.00225 \text{ mm. Ans.} \end{aligned}$$

$$\begin{aligned} \text{Similarly, } \delta t &= t \times \text{Lateral strain} \\ &= 20 \times 0.000075 = 0.0015 \text{ mm. Ans.} \end{aligned}$$

**Problem 2.2.** Determine the value of Young's modulus and Poisson's ratio of a metallic bar of length 30 cm, breadth 4 cm and depth 4 cm when the bar is subjected to an axial compressive load of 400 kN. The decrease in length is given as 0.075 cm and increase in breadth is 0.003 cm.

Sol. Given :

Length,  $L = 30 \text{ cm}$ ; Breadth,  $b = 4 \text{ cm}$ ; and Depth,  $d = 4 \text{ cm}$ .

$$\begin{aligned} \therefore \text{Area of cross-section, } A &= b \times d = 4 \times 4 \\ &= 16 \text{ cm}^2 = 16 \times 100 = 1600 \text{ mm}^2 \end{aligned}$$

Axial compressive load,  $P = 400 \text{ kN} = 400 \times 1000 \text{ N}$

Decrease in length,  $\delta L = 0.075 \text{ cm}$

Increase in breadth,  $\delta b = 0.003 \text{ cm}$

$$\text{Longitudinal strain} = \frac{\delta L}{L} = \frac{0.075}{30} = 0.0025$$

$$\text{Lateral strain} = \frac{\delta b}{b} = \frac{0.003}{4} = 0.00075.$$

Using equation (2.3),

$$\text{Poisson's ratio} = \frac{\text{Lateral strain}}{\text{Longitudinal strain}} = \frac{0.00075}{0.0025} = 0.3. \text{ Ans.}$$

$$\text{Longitudinal strain} = \frac{\text{Stress}}{E} = \frac{P}{A \times E} \quad \left( \because \text{Stress} = \frac{\text{Load}}{\text{Area}} = \frac{P}{A} \right)$$

or

$$0.0025 = \frac{400000}{1600 \times E}$$

$$\therefore E = \frac{400000}{1600 \times 0.0025} = 1 \times 10^5 \text{ N/mm}^2. \text{ Ans.}$$

## 2.5. VOLUMETRIC STRAIN

The ratio of change in volume to the original volume of a body (when the body is subjected to a single force or a system of forces) is called volumetric strain. It is denoted by  $e_v$ .

Mathematically, volumetric strain is given by

$$e_v = \frac{\delta V}{V}$$

where  $\delta V$  = Change in volume, and  
 $V$  = Original volume.

**2.5.1. Volumetric Strain of a Rectangular Bar which is Subjected to an Axial Load  $P$  in the Direction of its Length.** Consider a rectangular bar of length  $L$ , width  $b$  and depth  $d$  which is subjected to an axial load  $P$  in the direction of its length as shown in Fig. 2.2.

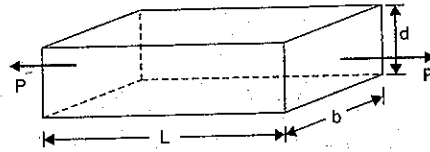

Fig. 2.2

Let  $\delta L$  = Change in length,  
 $\delta b$  = Change in width,  
 $\delta d$  = Change in depth.

and

$\therefore$  Final length of the bar =  $L + \delta L$   
 Final width of the bar =  $b + \delta b$   
 Final depth of the bar =  $d + \delta d$

Now original volume of the bar,  $V = L.b.d$

Final volume =  $(L + \delta L)(b + \delta b)(d + \delta d)$   
 $= L.b.d. + bd\delta L + Lb\delta d + Ld\delta b$

(Ignoring products of small quantities)

$\therefore$  Change in volume,

$$\begin{aligned} \delta V &= \text{Final volume} - \text{Original volume} \\ &= (Lbd + bd\delta L + Lb\delta d + Ld\delta b) - Lbd \\ &= bd\delta L + Lb\delta d + Ld\delta b \end{aligned}$$

$\therefore$  Volumetric strain,

$$\begin{aligned} e_v &= \frac{\delta V}{V} \\ &= \frac{bd\delta L + Lb\delta d + Ld\delta b}{Lbd} \\ &= \frac{\delta L}{L} + \frac{\delta d}{d} + \frac{\delta b}{b} \end{aligned} \quad \dots(2.4)$$

But  $\frac{\delta L}{L}$  = Longitudinal strain and  $\frac{\delta d}{d}$  or  $\frac{\delta b}{b}$  are lateral strains.

Substituting these values in the above equation, we get

$$e_v = \text{Longitudinal strain} + 2 \times \text{Lateral strain} \quad \dots(i)$$

From equation (2.3A), we have

$\therefore$  Lateral strain =  $-\mu \times$  Longitudinal strain.

Substituting the value of lateral strain in equation (i), we get

$$e_v = \text{Longitudinal strain} - 2 \times \mu \text{ longitudinal strain}$$

= Longitudinal strain  $(1 - 2\mu)$

$$= \frac{\delta L}{L} (1 - 2\mu) \quad \dots(2.5)$$

**Problem 2.3.** For the problem 2.1, determine the volumetric strain and final volume of the given steel bar.

**Sol.** Given :

The following data is given in problem 2.1. :

$$L = 4000 \text{ mm}, b = 30 \text{ mm}, t \text{ or } d = 20 \text{ mm}, \mu = 0.3.$$

Original volume,  $V = L.b.d = 4000 \times 30 \times 20 = 2400000 \text{ mm}^3$

The value of longitudinal strain (i.e.,  $\frac{\delta L}{L}$ ) in problem 2.1 is calculated

$$\frac{\delta L}{L} = 0.00025$$

as,

Now using equation (2.5), we have

$$\begin{aligned} \text{Volumetric strain, } e_v &= \frac{\delta L}{L} (1 - 2\mu) \\ &= 0.00025(1 - 2 \times 0.3) = \mathbf{0.0001. \text{ Ans.}} \end{aligned}$$

or

$$\frac{\delta V}{V} = 0.0001 \quad \left( \because e_v = \frac{\delta V}{V} \right)$$

$\therefore \delta V = 0.0001 \times V$

$$= 0.0001 \times 2400000 = 240 \text{ mm}^3$$

$\therefore$  Final volume = Original volume +  $\delta V$

$$= 2400000 + 240 \text{ mm}^3$$

$$= \mathbf{2400240 \text{ mm}^3. \text{ Ans.}}$$

**Problem 2.4.** A steel bar 300 mm long, 50 mm wide and 40 mm thick is subjected to a pull of 300 kN in the direction of its length. Determine the change in volume. Take  $E = 2 \times 10^5 \text{ N/mm}^2$  and  $\mu = 0.25$ .

**Sol.** Given :

Length,  $L = 300 \text{ mm}$

Width,  $b = 50 \text{ mm}$

Thickness,  $t = 40 \text{ mm}$

Pull,  $P = 300 \text{ kN} = 300 \times 10^3 \text{ N}$

Value of  $E = 2 \times 10^5 \text{ N/mm}^2$

Value of  $\mu = 0.25$

Original volume,  $V = L \times b \times t$

$$= 300 \times 50 \times 40 \text{ mm}^3 = 600000 \text{ mm}^3$$

The longitudinal strain (i.e., the strain in the direction of load) is given by

$$\frac{dL}{L} = \frac{\text{Stress in the direction of load}}{E}$$

But stress in the direction of load

$$= \frac{P}{\text{Area}} = \frac{P}{b \times t}$$

$$= \frac{300 \times 10^3}{50 \times 40} = 150 \text{ N/mm}^2$$

$$\therefore \frac{dL}{L} = \frac{150}{2 \times 10^5} = 0.00075$$

Now volumetric strain is given by equation (2.5) as

$$e_v = \frac{dL}{L} (1 - 2\mu) \\ = 0.00075 (1 - 2 \times 0.25) = 0.000375$$

Let  $\delta V$  = Change in volume. Then  $\frac{dV}{V}$  represents volumetric strain.

$$\therefore \frac{dV}{V} = 0.000375$$

or

$$dV = 0.000375 \times V \\ = 0.000375 \times 600000 = 225 \text{ mm}^3. \text{ Ans.}$$

**2.5.2. Volumetric Strain of a Rectangular Bar Subjected to Three Forces which are Mutually Perpendicular.** Consider a rectangular block of dimensions  $x$ ,  $y$  and  $z$  subjected to three direct tensile stresses along three mutually perpendicular axis as shown in Fig. 2.3.

Then volume of block,  $V = xyz$ .

Taking logarithm to both sides, we have

$$\log V = \log x + \log y + \log z.$$

Differentiating the above equation, we get

$$\frac{1}{V} dV = \frac{1}{x} dx + \frac{1}{y} dy + \frac{1}{z} dz$$

or

$$\frac{dV}{V} = \frac{dx}{x} + \frac{dy}{y} + \frac{dz}{z} \quad \dots(2.6)$$

But  $\frac{dV}{V} = \frac{\text{Change of volume}}{\text{Original volume}} = \text{Volumetric strain}$

$$\frac{dx}{x} = \frac{\text{Change of dimension } x}{\text{Original dimension } x} \\ = \text{Strain in the } x\text{-direction} = e_x$$

Similarly,  $\frac{dy}{y} = \text{Strain in } y\text{-direction} = e_y$

and

$$\frac{dz}{z} = \text{Strain in } z\text{-direction} = e_z$$

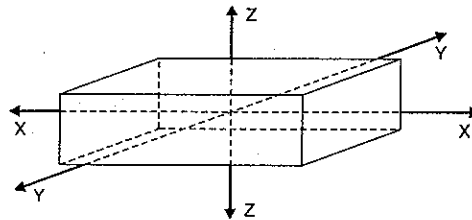

Fig. 2.3

Substituting these values in equation (2.6), we get

$$\frac{dV}{V} = e_x + e_y + e_z$$

Now, Let  $\sigma_x$  = Tensile stress in  $x$ - $x$  direction,  
 $\sigma_y$  = Tensile stress in  $y$ - $y$  direction, and  
 $\sigma_z$  = Tensile stress in  $z$ - $z$  direction.  
 $E$  = Young's modulus  
 $\mu$  = Poisson's ratio.

Now  $\sigma_x$  will produce a tensile strain equal to  $\frac{\sigma_x}{E}$  in the direction of  $x$ , and a compressive strain equal to  $\frac{\mu \times \sigma_x}{E}$  in the direction of  $y$  and  $z$ . Similarly,  $\sigma_y$  will produce a tensile strain equal to  $\frac{\sigma_y}{E}$  in the direction of  $y$  and a compressive strain equal to  $\frac{\mu \times \sigma_y}{E}$  in the direction of  $x$  and  $z$ . Similarly  $\sigma_z$  will produce a tensile strain equal to  $\frac{\sigma_z}{E}$  in the direction of  $z$  and a compressive strain equal to  $\frac{\mu \times \sigma_z}{E}$  in the direction of  $x$  and  $y$ . Hence  $\sigma_y$  and  $\sigma_z$  will produce compressive strains equal to  $\frac{\mu \times \sigma_y}{E}$  and  $\frac{\mu \times \sigma_z}{E}$  in the direction of  $x$ .

$\therefore$  Net tensile strain along  $x$ -direction is given by

$$e_x = \frac{\sigma_x}{E} - \frac{\mu \times \sigma_y}{E} - \frac{\mu \times \sigma_z}{E} = \frac{\sigma_x}{E} - \mu \left( \frac{\sigma_y + \sigma_z}{E} \right)$$

Similarly,  $e_y = \frac{\sigma_y}{E} - \mu \left( \frac{\sigma_x + \sigma_z}{E} \right)$

and

$$e_z = \frac{\sigma_z}{E} - \mu \left( \frac{\sigma_x + \sigma_y}{E} \right)$$

Adding all the strains, we get

$$e_x + e_y + e_z = \frac{1}{E} (\sigma_x + \sigma_y + \sigma_z) - \frac{2\mu}{E} (\sigma_x + \sigma_y + \sigma_z) \\ = \frac{1}{E} (\sigma_x + \sigma_y + \sigma_z) (1 - 2\mu).$$

But  $e_x + e_y + e_z = \text{Volumetric strain} = \frac{dV}{V}$ .

$$\therefore \frac{dV}{V} = \frac{1}{E} (\sigma_x + \sigma_y + \sigma_z) (1 - 2\mu) \quad \dots(2.7)$$

Equation (2.7) gives the volumetric strain. In this equation the stresses  $\sigma_x$ ,  $\sigma_y$  and  $\sigma_z$  are all tensile. If any of the stresses is compressive, it may be regarded as negative, and the above equation will hold good. If the value of  $\frac{dV}{V}$  is positive, it represents increase in volume whereas the negative value of  $\frac{dV}{V}$  represents a decrease in volume.



**Problem 2.5.** A metallic bar  $300 \text{ mm} \times 100 \text{ mm} \times 40 \text{ mm}$  is subjected to a force of  $5 \text{ kN}$  (tensile),  $6 \text{ kN}$  (tensile) and  $4 \text{ kN}$  (tensile) along  $x$ ,  $y$  and  $z$  directions respectively. Determine the change in the volume of the block. Take  $E = 2 \times 10^5 \text{ N/mm}^2$  and Poisson's ratio  $= 0.25$ .

**Sol. Given :**

Dimensions of bar =  $300 \text{ mm} \times 100 \text{ mm} \times 40 \text{ mm}$   
 $\therefore x = 300 \text{ mm}$ ,  $y = 100 \text{ mm}$  and  $z = 40 \text{ mm}$   
 $\therefore$  Volume,  $V = x \times y \times z = 300 \times 100 \times 40$   
 $= 1200000 \text{ mm}^3$   
 Load in the direction of  $x = 5 \text{ kN} = 5000 \text{ N}$   
 Load in the direction of  $y = 6 \text{ kN} = 6000 \text{ N}$   
 Load in the direction of  $z = 4 \text{ kN} = 4000 \text{ N}$   
 Value of  $E = 2 \times 10^5 \text{ N/mm}^2$   
 Poisson's ratio,  $\mu = 0.25$

$\therefore$  Stress in the  $x$ -direction,

$$\sigma_x = \frac{\text{Load in } x\text{-direction}}{y \times z}$$

$$= \frac{5000}{100 \times 40} = 1.25 \text{ N/mm}^2$$

Similarly the stress in  $y$ -direction is given by,

$$\sigma_y = \frac{\text{Load in } y\text{-direction}}{x \times z}$$

$$= \frac{6000}{300 \times 40} = 0.5 \text{ N/mm}^2$$

And stress in  $z$ -direction =  $\frac{\text{Load in } z\text{-direction}}{x \times y}$

$$\sigma_z = \frac{4000}{300 \times 100}$$

$$= 0.133 \text{ N/mm}^2$$

or

Using equation (2.9), we get

$$\frac{dV}{V} = \frac{1}{E} (\sigma_x + \sigma_y + \sigma_z)(1 - 2\mu)$$

$$= \frac{1}{2 \times 10^5} (1.25 + 0.5 + 0.113)(1 - 2 \times 0.25)$$

$$= \frac{1.883}{2 \times 10^5 \times 2}$$

$$\therefore dV = \frac{1.883}{4 \times 10^5} \times V$$

$$= \frac{1.883}{4 \times 10^5} \times 1200000$$

$$= 5.649 \text{ mm}^3. \text{ Ans.}$$

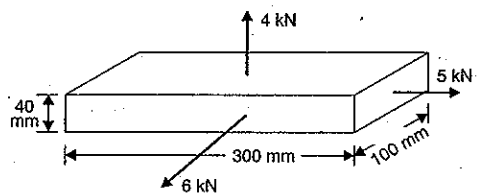

Fig. 2.4

**Problem 2.6.** A metallic bar  $250 \text{ mm} \times 100 \text{ mm} \times 50 \text{ mm}$  is loaded as shown in Fig. 2.5.

Find the change in volume. Take  $E = 2 \times 10^5 \text{ N/mm}^2$  and Poisson's ratio  $= 0.25$ .

Also find the change that should be made in the  $4 \text{ MN}$  load, in order that there should be no change in the volume of the bar.

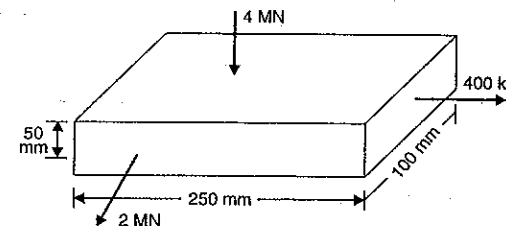

Fig. 2.5

**Sol. Given :**

Length,  $x = 250 \text{ mm}$ ,  $y = 100 \text{ mm}$  and  $z = 50 \text{ mm}$   
 $\therefore$  Volume,  $V = xyz = 250 \times 100 \times 50 = 1250000 \text{ mm}^3$   
 Load in  $x$ -direction =  $400 \text{ kN} = 400000 \text{ N}$  (tensile)  
 Load in  $y$ -direction =  $2 \text{ MN} = 2 \times 10^6 \text{ N}$  (tensile)  
 Load in  $z$ -direction =  $4 \text{ MN} = 4 \times 10^6 \text{ N}$  (compressive)  
 Modulus of elasticity,  $E = 2 \times 10^5 \text{ N/mm}^2$   
 Poisson's ratio,  $\mu = 0.25$ .

Now

$$\sigma_x = \text{Stress in } x\text{-direction}$$

$$= \frac{\text{Load in } x\text{-direction}}{\text{Area of cross-section}}$$

$$= \frac{400000}{y \times z} = \frac{400000}{100 \times 50} = 80 \text{ N/mm}^2 \text{ (tension).}$$

Similarly,

$$\sigma_y = \frac{\text{Load in } y\text{-direction}}{x \times z}$$

$$= \frac{2 \times 10^6}{250 \times 50} = 160 \text{ N/mm}^2$$

and

$$\sigma_z = \frac{4000000}{250 \times 100}$$

$$= 160 \text{ N/mm}^2 \text{ (compression).}$$

Using equation (2.7) and taking tensile stresses positive and compressive stresses negative, we get

$$\frac{dV}{V} = \frac{1}{E} (\sigma_x + \sigma_y + \sigma_z)(1 - 2\mu)$$

$$\text{or } \frac{dV}{V} = \frac{1}{2 \times 10^5} (80 + 160 - 160)(1 - 2 \times 0.25)$$

$$= \frac{80}{2 \times 10^5} \times 0.5 = 0.0002.$$

$\therefore$  Change in volume,

$$dV = 0.0002 \times V$$

$$= 0.0002 \times 1250000$$

$$= 250 \text{ mm}^3. \text{ Ans.}$$

Change in the 4 MN load when there is no change in volume of bar

$$\text{Using equation (2.7), } \frac{dV}{V} = \frac{1}{E} (\sigma_x + \sigma_y + \sigma_z)(1 - 2\mu)$$

If there is no change in volume, then  $\frac{dV}{V} = 0$

$$\therefore \frac{1}{E} (\sigma_x + \sigma_y + \sigma_z)(1 - 2\mu) = 0.$$

But for most of materials, the value of  $\mu$  lies between 0.25 and 0.33 and hence the term  $(1 - 2\mu)$  is never zero.

$$\therefore \sigma_x + \sigma_y + \sigma_z = 0.$$

The stresses  $\sigma_x$  and  $\sigma_y$  are not to be changed. Only the stress corresponding to the load 4 MN (i.e., stress in z-direction) is to be changed.

$$\therefore \sigma_z = -\sigma_x - \sigma_y = -80 - 160 = -240 \text{ N/mm}^2 \text{ (compressive)}$$

$$\text{But } \sigma_z = \frac{\text{Load}}{\text{Area}} = \frac{\text{Load}}{x \times y} \text{ or } 240 = \frac{\text{Load}}{250 \times 100}$$

$$\therefore \text{Load} = 240 \times 250 \times 100 = 6 \times 10^6 \text{ N} = 6 \text{ MN}$$

But already a compressive load of 4 MN is acting.

$\therefore$  Additional load that must be added

$$= 6 \text{ MN} - 4 \text{ MN} = 2 \text{ MN (compressive)}. \text{ Ans.}$$

## 2.6. VOLUMETRIC STRAIN OF A CYLINDRICAL ROD

Consider a cylindrical rod which is subjected to an axial tensile load  $P$ .

Let  $d$  = diameter of the rod

$L$  = length of the rod

Due to tensile load  $P$ , there will be an increase in the length of the rod, but the diameter of the rod will decrease as shown in Fig. 2.6.

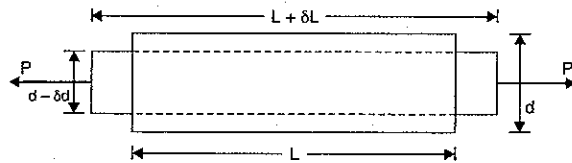

Fig. 2.6

$$\therefore \text{Final length} = L + \delta L$$

$$\therefore \text{Final diameter} = d - \delta d$$

Now original volume of the rod,

$$L = \frac{\pi}{4} d^2 \times L$$

$$\text{Final volume} = \frac{\pi}{4} (d - \delta d)^2 (L + \delta L)$$

$$= \frac{\pi}{4} (d^2 + \delta d^2 - 2d \times \delta d)(L + \delta L)$$

$$= \frac{\pi}{4} (d^2 \times L + \delta d^2 \times L - 2d \times L \times \delta d + d^2 \times \delta L + \delta d^2 \times \delta L - 2d \times \delta d \times \delta L)$$

$$= \frac{\pi}{4} (d^2 \times L - 2d \times L \times \delta d + d^2 \times \delta L)$$

Neglecting the products and higher powers of two small quantities.

$\therefore$  Change in volume,  $\delta V = \text{Final volume} - \text{Original volume}$

$$= \frac{\pi}{4} (d^2 \times L - 2d \times L \times \delta d + d^2 \times \delta L) - \frac{\pi}{4} d^2 \times L$$

$$= \frac{\pi}{4} (d^2 \times \delta L - 2d \times L \times \delta d)$$

$$\therefore \text{Volumetric strain, } e_v = \frac{\text{Change in volume}}{\text{Original volume}} = \frac{\delta V}{V}$$

$$= \frac{\frac{\pi}{4} (d^2 \times \delta L - 2d \times L \times \delta d)}{\frac{\pi}{4} d^2 \times L} = \frac{\delta L}{L} - \frac{2\delta d}{d} \quad \dots(2.8)$$

where  $\frac{\delta L}{L}$  is the strain of length and  $\frac{\delta d}{d}$  is the strain of diameter.

$\therefore$  Volumetric strain = Strain in length - Twice the strain of diameter.

**Problem 2.7.** A steel rod 5 m long and 30 mm in diameter is subjected to an axial tensile load of 50 kN. Determine the change in length, diameter and volume of the rod. Take  $E = 2 \times 10^5 \text{ N/mm}^2$  and Poisson's ratio = 0.25.

**Sol.** Given :

$$\text{Length, } L = 5 \text{ m} = 5 \times 10^3 \text{ mm}$$

$$\text{Diameter, } d = 30 \text{ mm}$$

$$\therefore \text{Volume, } V = \frac{\pi}{4} d^2 \times L = \frac{\pi}{4} (30)^2 \times 5 \times 10^3 = 35.343 \times 10^5$$

$$\text{Tensile load, } P = 50 \text{ kN} = 50 \times 10^3$$

$$\text{Value of } E = 2 \times 10^5 \text{ N/mm}^2$$

$$\text{Poisson's ratio, } \mu = 0.25$$

Let  $\delta d = \text{Change in diameter}$

$\delta L = \text{Change in length}$

$\delta V = \text{Change in volume}$

$$\text{Now strain of length} = \frac{\text{Stress}}{E}$$

$$= \frac{\text{Load}}{\text{Area}} \times \frac{1}{E} \quad \left( \because \text{Stress} = \frac{\text{Load}}{\text{Area}} \right)$$

$$= \frac{P}{\frac{\pi}{4} \times d^2} \times \frac{1}{E} = \frac{50 \times 10^3}{\frac{\pi}{4} \times 30^2} \times \frac{1}{2 \times 10^5}$$

$$= \frac{0.4 \times 50 \times 10^3}{\pi \times 30^2 \times 2 \times 10^5} = 0.0003536$$

But strain of length =  $\frac{\delta L}{L}$

$$\therefore \frac{\delta L}{L} = 0.0003536$$

$$\therefore \delta L = 0.0003536 \times 5 \times 10^3 = 1.768 \text{ mm. Ans.}$$

Now Poisson's ratio =  $\frac{\text{Lateral strain}}{\text{Longitudinal strain}}$

$$\therefore \text{Lateral strain} = \text{Poisson's ratio} \times \text{Longitudinal strain}$$

$$= 0.25 \times 0.0003536 \quad \left( \because \text{Longitudinal strain} = \frac{\delta L}{L} \right)$$

$$= 0.0000884$$

But Lateral strain =  $\frac{\delta d}{d}$

$$\therefore \frac{\delta d}{d} = 0.0000884$$

$$\therefore \delta d = 0.0000884 \times d = 0.0000884 \times 30 = 0.002652 \text{ mm}$$

Now using equation (2.8), we get

$$\text{Volumetric strain, } \frac{\delta V}{V} = \frac{\delta L}{L} + \frac{2\delta d}{d} = 0.0003536 - 2 \times 0.0000884 = 0.0001768$$

$$\therefore \delta V = V \times 0.0001768 = 35.343 \times 10^5 \times 0.0001768 = 624.86 \text{ mm}^3. \text{ Ans.}$$

## 2.7. BULK MODULUS

When a body is subjected to the mutually perpendicular like and equal direct stresses, the ratio of direct stress to the corresponding volumetric strain is found to be constant for a given material when the deformation is within a certain limit. This ratio is known as bulk modulus and is usually denoted by  $K$ . Mathematically bulk modulus is given by

$$K = \frac{\text{Direct stress}}{\text{Volumetric strain}} = \frac{\sigma}{\left(\frac{dV}{V}\right)} \quad \dots(2.9)$$

## 2.8. EXPRESSION FOR YOUNG'S MODULUS IN TERMS OF BULK MODULUS

Fig. 2.7 shows a cube  $ABCDEFGH$  which is subjected to three mutually perpendicular tensile stresses of equal intensity.

Let  $L$  = Length of cube

$dL$  = Change in length of the cube

$E$  = Young's modulus of the material of the cube

$\sigma$  = Tensile stress acting on the faces

$\mu$  = Poisson's ratio.

Then volume of cube,  $V = L^3$

Now let us consider the strain of one of the sides of the cube (say  $AB$ ) under the action of the three mutually perpendicular stresses. This side will suffer the following three strains :

1. Strain of  $AB$  due to stresses on the faces  $AEHD$  and  $BFGC$ . This strain is tensile and is equal to  $\frac{\sigma}{E}$ .
2. Strain of  $AB$  due to stresses on the faces  $AEFB$  and  $DHGC$ . This is compressive lateral strain and is equal to  $-\mu \frac{\sigma}{E}$ .
3. Strain of  $AB$  due to stresses on the faces  $ABCD$  and  $EFGH$ . This is also compressive lateral strain and is equal to  $-\mu \frac{\sigma}{E}$ .

Hence the total strain of  $AB$  is given by

$$\frac{dL}{L} = \frac{\sigma}{E} - \mu \times \frac{\sigma}{E} - \mu \times \frac{\sigma}{E} = \frac{\sigma}{E} (1 - 2\mu) \quad \dots(i)$$

Now original volume of cube,  $V = L^3$  ... (ii)

If  $dL$  is the change in length, then  $dV$  is the change in volume.

Differentiating equation (ii), with respect to  $L$ ,

$$dV = 3L^2 \times dL \quad \dots(iii)$$

Dividing equation (iii) by equation (ii), we get

$$\frac{dV}{V} = \frac{3L^2 \times dL}{L^3} = \frac{3dL}{L}$$

Substituting the value of  $\frac{dL}{L}$  from equation (i), in the above equation, we get

$$\frac{dV}{V} = \frac{3\sigma}{E} (1 - 2\mu)$$

From equation (2.9), bulk modulus is given by

$$K = \frac{\sigma}{\left(\frac{dV}{V}\right)} = \frac{\sigma}{\frac{3\sigma}{E} (1 - 2\mu)} \quad \left[ \because \frac{dV}{V} = \frac{3\sigma}{E} (1 - 2\mu) \right]$$

$$= \frac{E}{3(1 - 2\mu)} \quad \dots(2.10)$$

or

$$E = 3K(1 - 2\mu) \quad \dots(2.11)$$

From equation (2.11), the expression for Poisson's ratio ( $\mu$ ) is obtained as  $\mu = \frac{3K - E}{6K}$ .

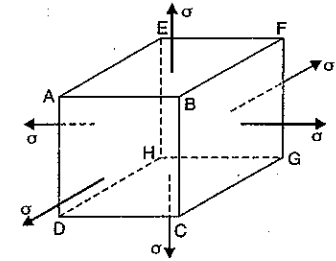

Fig. 2.7

**Problem 2.8.** For a material, Young's modulus is given as  $1.2 \times 10^5 \text{ N/mm}^2$  and Poisson's ratio  $\frac{1}{4}$ . Calculate the Bulk modulus.

**Sol.** Given : Young's modulus,  $E = 1.2 \times 10^5 \text{ N/mm}^2$

Poisson's ratio,  $\mu = \frac{1}{4}$

Let  $K =$  Bulk modulus

Using equation (2.10),

$$K = \frac{E}{3(1-2\mu)} = \frac{1.2 \times 10^5}{3\left(1-\frac{2}{4}\right)} = \frac{1.2 \times 10^5}{3 \times \frac{1}{2}}$$

$$= \frac{2 \times 1.2 \times 10^5}{3} = 0.8 \times 10^5 \text{ N/mm}^2. \text{ Ans.}$$

**Problem 2.9.** A bar of 30 mm diameter is subjected to a pull of 60 kN. The measured extension on gauge length of 200 mm is 0.1 mm and change in diameter is 0.004 mm. Calculate :

(i) Young's modulus

(ii) Poisson's ratio and

(iii) Bulk modulus.

**Sol.** Given : Dia. of bar,  $d = 30 \text{ mm}$

$\therefore$  Area of bar,  $A = \frac{\pi}{4} (30)^2 = 225\pi \text{ mm}^2$

Pull,  $P = 60 \text{ kN} = 60 \times 1000 \text{ N}$

Gauge length,  $L = 200 \text{ mm}$

Extension,  $\delta L = 0.1 \text{ mm}$

Change in dia.,  $\delta d = 0.004 \text{ mm}$

(i) Young's modulus ( $E$ )

Tensile stress,  $\sigma = \frac{P}{A} = \frac{60000}{225\pi} = 84.87 \text{ N/mm}^2$

Longitudinal strain  $= \frac{\delta L}{L} = \frac{0.1}{200} = 0.0005$

$\therefore$  Young's modulus,  $E = \frac{\text{Tensile stress}}{\text{Longitudinal strain}}$

$$= \frac{84.87}{0.0005} = 16.975 \times 10^4 \text{ N/mm}^2$$

$$= 1.6975 \times 10^5 \text{ N/mm}^2. \text{ Ans.}$$

(ii) Poisson's ratio ( $\mu$ )

Poisson's ratio is given by equation (2.3) as

Poisson's ratio  $(\mu) = \frac{\text{Lateral strain}}{\text{Longitudinal strain}}$

$$= \frac{\left(\frac{\delta d}{d}\right)}{0.0005}$$

$$\left(\because \text{Lateral strain} = \frac{\delta d}{d}\right)$$

$$= \frac{\left(\frac{0.004}{30}\right)}{0.0005} = \frac{0.000133}{0.0005} = 0.266. \text{ Ans.}$$

(iii) Bulk modulus ( $K$ )

Using equation (2.10), we get

$$K = \frac{E}{3(1-2\mu)} = \frac{1.6975 \times 10^5}{3(1-0.266 \times 2)}$$

$$= 1.209 \times 10^5 \text{ N/mm}^2. \text{ Ans.}$$

## 2.9. PRINCIPLE OF COMPLEMENTARY SHEAR STRESSES

It states that a set of shear stresses across a plane is always accompanied by a set of balancing shear stresses (i.e., of the same intensity) across the plane and normal to it.

**Proof.** Fig. 2.8 shows a rectangular block  $ABCD$ , subjected to a set of shear stresses of intensity  $\tau$  on the faces  $AB$  and  $CD$ . Let the thickness of the block normal to the plane of the paper is unity.

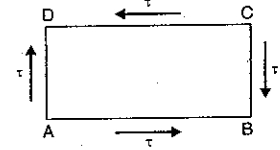

Fig. 2.8

The force acting on face  $AB$

$$= \text{Stress} \times \text{Area}$$

$$= \tau \times AB \times 1 = \tau \cdot AB$$

Similarly force acting on face  $CD$

$$= \tau \times CD \times 1 = \tau \cdot CD$$

$$= \tau \cdot AB$$

$$(\because CD = AB)$$

The forces acting on the faces  $AB$  and  $CD$  are equal and opposite and hence these forces will form a couple.

The moment of this couple = Force  $\times$  Perpendicular distance

$$= \tau \cdot AB \times AD \quad \dots(i)$$

If the block is in equilibrium, there must be a restoring couple whose moment must be equal to the moment given by equation (i). Let the shear stress of intensity  $\tau'$  is set up on the faces  $AD$  and  $CB$ .

The force acting on face  $AD = \tau' \times AD \times 1 = \tau' \cdot AD$

The force acting on face  $BC = \tau' \times BC \times 1 = \tau' \cdot BC = \tau' \cdot AD$

$$(\because BC = AD)$$

As the force acting on faces  $AD$  and  $BC$  are equal and opposite, these forces also forms a couple.

Moment of this couple = Force  $\times$  Distance =  $\tau' \cdot AD \times AB$

$$\dots(ii)$$

For the equilibrium of the block, the moments of couples given by equations (i) and (ii) should be equal

$$\therefore \tau \cdot AB \times AD = \tau' \cdot AD \times AB \text{ or } \tau = \tau'$$

The above equation proves that a set of shear stresses is always accompanied by a transverse set of shear stresses of the same intensity.

The stress  $\tau'$  is known as complementary shear and the two stresses ( $\tau$  and  $\tau'$ ) at right angles together constitute a state of simple shear. The direction of the shear stresses on the block are either both towards or both away from a corner.

In Fig. 2.8, as a result of two couples, formed by the shear forces, the diagonal  $BD$  will be subjected to tension and the diagonal  $AB$  will be subjected to compression.

## 2.10. STRESSES ON INCLINED SECTIONS WHEN THE ELEMENT IS SUBJECTED TO SIMPLE SHEAR STRESSES

Fig. 2.9 shows a rectangular block  $ABCD$  which is in a state of simple shear and hence subjected to a set of shear stresses of intensity  $\tau$  on the faces  $AB$ ,  $CD$  and the faces  $AD$  and  $CB$ . Let the thickness of the block normal to the plane of the paper is unity.

It is required to find the normal and tangential stresses across an inclined plane  $CE$ , which is having inclination  $\theta$  with the face  $CB$ .

Consider the equilibrium of the triangular piece  $CEB$  of thickness unity. The forces acting on triangular piece  $CEB$  are shown in Fig. 2.10 and they are :

(i) Shear force on face  $CB$ ,

$$Q_1 = \text{Shear stress} \times \text{area of face } CB \\ = \tau \times BC \times 1 \\ = \tau \times BC \text{ acting along } CB$$

(ii) Shear force on face  $EB$ ,

$$Q_2 = \text{Shear stress} \times \text{area of face } EB \\ = \tau \times EB \times 1 = \tau \times EB \text{ acting along } EB$$

(iii) A force  $P_n$  normal to the plane  $EC$

(iv) A force  $P_t$  tangential to the plane  $EC$

The force  $Q_1$  is acting along the face  $CB$  as shown in Fig. 2.11. This force is resolved into two components, i.e.,  $Q_1 \cos \theta$  and  $Q_1 \sin \theta$  along the plane  $CE$  and normal to the plane  $CE$  respectively.

The force  $Q_2$  is acting along the face  $EB$ . This force is also resolved into two components, i.e.,  $Q_2 \sin \theta$  and  $Q_2 \cos \theta$  along the plane  $EC$  and normal to the plane  $EC$  respectively.

For equilibrium, the net force normal to the plane  $CE$  should be zero.

$$\therefore P_n - Q_1 \sin \theta - Q_2 \cos \theta = 0$$

$$\text{or } P_n = Q_1 \sin \theta + Q_2 \cos \theta \\ = \tau \times BC \times \sin \theta + \tau \times EB \times \cos \theta$$

$$(\because Q_1 = \tau \times BC \text{ and } Q_2 = \tau \times EB)$$

For equilibrium, the net force along the plane  $CE$  should be zero.

$$\therefore P_t - Q_1 \cos \theta + Q_2 \sin \theta = 0$$

$$\text{or } P_t = Q_1 \cos \theta - Q_2 \sin \theta \\ (-ve \text{ sign is taken due to opposite direction}) \\ = \tau \times BC \times \cos \theta - \tau \times EB \times \sin \theta$$

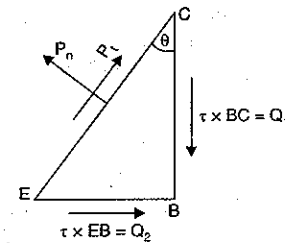
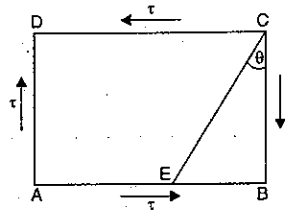

Fig. 2.10

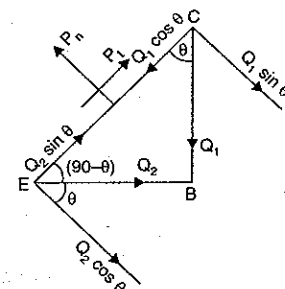

Fig. 2.11

Let  $\sigma_n$  = Normal stress on plane  $CE$   
 $\sigma_t$  = Tangential stress on plane  $CE$

$$\text{Then } \sigma_n = \frac{\text{Normal force on plane } CE}{\text{Area of section } CE} \\ = \frac{P_n}{CE \times 1} = \frac{\tau \times BC \times \sin \theta + \tau \times EB \times \cos \theta}{CE \times 1} \\ = \tau \times \frac{BC}{CE} \times \sin \theta + \tau \times \frac{EB}{CE} \times \cos \theta \\ = \tau \times \cos \theta \times \sin \theta + \tau \times \sin \theta \times \cos \theta \\ (\because \text{In triangle } EBC, \frac{BC}{CE} = \cos \theta \text{ and } \frac{EB}{CE} = \sin \theta) \\ = 2\tau \cos \theta \times \sin \theta = \tau \sin 2\theta \quad \dots(2.12)$$

$$\text{and } \sigma_t = \frac{\text{Tangential force on plane } CE}{\text{Area of plane } CE} \\ = \frac{P_t}{CE \times 1} = \frac{\tau \times BC \times \cos \theta - \tau \times EB \times \sin \theta}{CE} \\ = \tau \times \frac{BC}{CE} \times \cos \theta - \tau \times \frac{EB}{CE} \times \sin \theta \\ = \tau \times \cos \theta \times \cos \theta - \tau \times \sin \theta \times \sin \theta \\ = \tau \cos^2 \theta - \tau \sin^2 \theta \\ = \tau [\cos^2 \theta - \sin^2 \theta] = \tau \cos 2\theta \quad \dots(2.13)$$

For the planes carrying the maximum normal stress,  $\sigma_n$  should be maximum. But from equation (2.12) it is clear that  $\sigma_n$  will be maximum when  $\sin 2\theta = \pm 1$

$$\text{i.e., } 2\theta = \pm \frac{\pi}{2}$$

$$\text{or } \theta = \pm \frac{\pi}{4} \text{ which means } \theta = 45^\circ \text{ or } -45^\circ$$

when  $\theta = 45^\circ$ , then from equation (2.12), we have

$$\sigma_n = \tau \sin 90^\circ = \tau$$

when  $\theta = -45^\circ$ , then  $\sigma_n = -\tau$

(Positive sign shows the normal stress is tensile whereas negative sign shows the normal stress is compressive).

When  $\theta = \pm 45^\circ$ , then from equation (2.13), we find that

$$\sigma_t = \tau \cos 2 \times 45^\circ \\ = \tau \cos 90^\circ = 0$$

This shows that the planes, which carry the maximum normal stresses, are having zero shear stresses.

Now from equation 2.13, it is clear that shear stress will be maximum when  $\cos 2\theta = \pm 1$ ,

$$\text{i.e., } 2\theta = 0^\circ \text{ or } 180^\circ \text{ or } \theta = 0^\circ \text{ or } 90^\circ$$

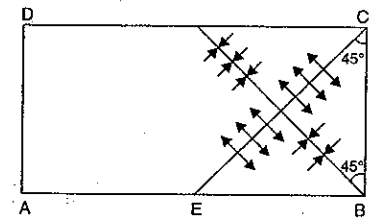

Fig. 2.12

When  $\theta = 0^\circ$  or  $90^\circ$ , the value of  $\sigma_n$  from equation (2.12), is zero.

This shows that the planes, which carry the maximum shear stresses, are having zero normal stresses. These planes are known as planes of simple shear.

**Important points.** When an element is subjected to a set of shear stresses, then :

- (i) The planes of maximum normal stresses are perpendicular to each other.
- (ii) The planes of maximum normal stresses are inclined at an angle of  $45^\circ$  to the planes of pure shear.
- (iii) One of the maximum normal stress is tensile while the other maximum normal stress is compressive.
- (iv) The maximum normal stresses are of the same magnitude and are equal to the intensity of shear stress on the plane of pure shear.

## 2.11. DIAGONAL STRESSES PRODUCED BY SIMPLE SHEAR ON A SQUARE BLOCK

Fig. 2.13 shows a square block  $ABCD$  of each side equal to 'a' and subjected to a set of shear stresses of intensity  $\tau$  on the faces  $AB, CD$  and faces  $AD$  and  $CB$ . Let the thickness of the block normal to the plane of the paper is unity.

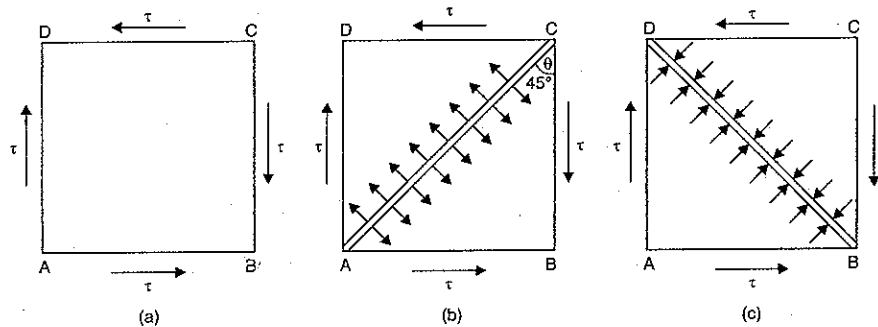

Fig. 2.13

The normal stress ( $\sigma_n$ ) on plane  $AC$  is given by equation (2.12) as

$$\sigma_n = \tau \sin 2\theta \quad \dots(i)$$

But as shown in Fig. 2.13 (b) the angle made by plane  $AC$  with face  $BC$  is given by,

$$\tan \theta = \frac{AB}{BC} = \frac{a}{a} = 1 \quad [\because ABCD \text{ is a square of side 'a'}]$$

$$\therefore \theta = 45^\circ$$

Substituting this value of  $\theta$  in equation (i), we get

$$\sigma_n = \tau \times \sin 2 \times 45^\circ = \tau \times \sin 90^\circ = \tau$$

$$\text{and } \sigma_t = \tau \times \cos 2\theta = \tau \times \cos 2 \times 45^\circ = \tau \times \cos 90^\circ = 0$$

Hence on the plane  $AC$ , a direct tensile stress of magnitude  $\tau$  is acting. This tensile stress is parallel to the diagonal  $BD$ . Hence the diagonal  $BD$  is subjected to tensile stress of magnitude  $\tau$ .

Similarly it can be proved that on the plane  $BD$ , a direct compressive stress of magnitude  $\tau$  is acting. This compressive stress is perpendicular to the plane  $BD$  or this compressive stress is along the diagonal  $AC$ . Hence the diagonal  $AC$  is subjected to compressive stress of magnitude  $\tau$ . The pure direct tensile and compressive stresses active on the diagonal planes  $AC$  and  $BD$  are called diagonal tensile and diagonal compressive stresses. The stress on the diagonal plane  $AC$  (i.e., along diagonal  $BD$ ) is tensile whereas on the diagonal plane  $BD$  i.e., along the diagonal  $AC$  is compressive.

Hence the set of shear stresses  $\tau$  on the faces  $AB, CD$  and the faces  $AD$  and  $CB$  are equivalent to a compressive stress  $\tau$  along the diagonal  $AC$  and a tensile stress  $\tau$  along the diagonal  $BD$ .

## 2.12. DIRECT (TENSILE AND COMPRESSIVE) STRAINS OF THE DIAGONALS

In Art. 2.11, we have proved that when a square block  $ABCD$  of unit thickness is subjected to a set of shear stresses of intensity  $q$  on the faces  $AB, CD$  and the faces  $AD$  and  $CB$ , the diagonal  $BD$  will experience a tensile stress of magnitude  $q$  whereas the diagonal  $AC$  will experience a compressive stress of magnitude  $q$ . Due to these stresses the diagonal  $BD$  will be elongated whereas the diagonal  $AC$  will be shortened. Let us consider the joint effect of these two stresses on the diagonal  $BD$ .

Due to the tensile stress  $q$  along diagonal  $BD$ , there will be a tensile strain in diagonal  $BD$ . Due to the compressive stress  $q$  along the diagonal  $AC$ , there will be a tensile strain in the diagonal  $BD$  due to lateral strain.\*

Let  $\mu$  = Poisson's ratio

$E$  = Young's modulus for the material of the block

Now tensile strain in diagonal  $BD$  due to tensile stress  $\tau$  along  $BD$

$$= \frac{\text{Tensile stress along } BD}{E} = \frac{\tau}{E}$$

Tensile strain in diagonal  $BD$  due to compressive stress  $\tau$  along  $AC$

$$= \frac{\mu \times \tau}{E}$$

$\therefore$  Total tensile strain along diagonal  $BD$

$$= \frac{\tau}{E} + \frac{\mu \times \tau}{E} = \frac{\tau}{E} (1 + \mu) \quad \dots(2.14)$$

Similarly it can be proved that the total strain in the diagonal  $AC$  will be compressive and will be given by

Total compressive strain in diagonal  $AC$

$$= \frac{\tau}{E} (1 + \mu).$$

The total tensile strain in the diagonal  $BD$  is equal to half the shear strain. This is proved as given below :

\*Please refer to Art. 2.4, in which it is proved that every strain in the direction of load is accompanied by lateral strain of the opposite kind perpendicular to the direction of load.

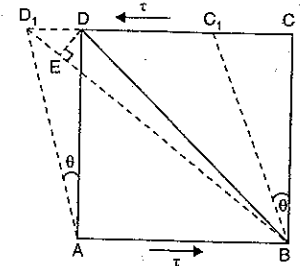

Fig. 2.14

Due to the shear stresses acting on the faces, the square block  $ABCD$  will be deformed to position  $ABC_1D_1$  as shown in Fig. 2.14.

Now increase in the length of diagonal  $BD = BD_1 - BD$

∴ Tensile strain in the diagonal  $BD$

$$= \frac{\text{Increase in length}}{\text{Original length}} = \frac{BD_1 - BD}{BD} \quad \dots(i)$$

From  $D$ , draw a perpendicular  $DE$  on  $BD_1$ .

We know that the distortion  $DD_1$  is very small and hence angle  $DBD_1$  will be very small.

Hence we can take

$$BD = BE$$

and

$$\angle CDB = \angle C_1D_1B = 45^\circ$$

Now in triangle  $DD_1E$ ,  $\angle DD_1E = 45^\circ$

∴ Length  $D_1E = DD_1 \cos(\angle DD_1E)$

$$= DD_1 \cos 45^\circ = \frac{DD_1}{\sqrt{2}}$$

In triangle  $ABD$ ,  $BD = \sqrt{AB^2 + AD^2}$

$$= \sqrt{AD^2 + AD^2} = \sqrt{2} \times AD \quad (\because AB = AD)$$

Now from equation (i), we have

Tensile strain in diagonal

$$\begin{aligned} BD &= \frac{BD_1 - BD}{BD} \\ &= \frac{BD_1 - BE}{BD} \quad [\because BD = BE] \end{aligned}$$

$$= \frac{D_1E}{BD} \quad [\because BD_1 - BE = D_1E]$$

$$= \frac{\left(\frac{DD_1}{\sqrt{2}}\right)}{\sqrt{2} \times AD} \quad \left(\because D_1E = \frac{DD_1}{\sqrt{2}} \text{ and } BD = \sqrt{2} \times AD\right)$$

$$= \frac{1}{\sqrt{2} \times \sqrt{2}} \times \frac{DD_1}{AD} = \frac{1}{2} \frac{DD_1}{AD}$$

$$= \frac{1}{2} \text{ Shear strain}^* \quad \left(\because \text{Shear strain} = \frac{DD_1}{AD}\right) \quad \dots(2.15)$$

### 2.13. RELATIONSHIP BETWEEN MODULUS OF ELASTICITY AND MODULUS OF RIGIDITY

We have seen in the last article that when a square block of unit thickness is subjected to a set of shear stresses of magnitude  $\tau$  on the faces  $AB$ ,  $CD$  and the faces  $AD$  and  $CB$ , then the

\*Please refer to Art. 1.4.3, for shear strain.

diagonal strain due to shear stress  $\tau$  is given by equation (2.14) as

$$\text{Total tensile strain along diagonal } BD = \frac{\tau}{E} (1 + \mu)$$

From equation (2.15) also we have total tensile strain in diagonal  $BD$

$$= \frac{1}{2} \text{ shear strain} = \frac{1}{2} \times \frac{\text{Shear stress}}{C} \quad \left(\frac{\text{Shear stress}}{\text{Shear strain}} = \text{modulus of rigidity} = C\right)$$

$$= \frac{1}{2} \times \frac{\tau}{C} \quad (\because \text{Shear stress} = \tau)$$

∴ Equating the two tensile strain along diagonal  $BD$ , we get

$$\frac{\tau}{E} (1 + \mu) = \frac{1}{2} \times \frac{\tau}{C}$$

$$\text{or} \quad \frac{\tau}{E} (1 + \mu) = \frac{1}{2C} \quad (\text{Cancelling } \tau \text{ to both sides})$$

$$\therefore E = 2C (1 + \mu) \quad \dots(2.16)$$

$$\text{or} \quad C = \frac{E}{2(1 + \mu)} \quad \dots(2.17)$$

**Problem 2.10.** Determine the Poisson's ratio and bulk modulus of a material, for which Young's modulus is  $1.2 \times 10^5 \text{ N/mm}^2$  and modulus of rigidity is  $4.8 \times 10^4 \text{ N/mm}^2$ .

**Sol.** Given :

Young's modulus,  $E = 1.2 \times 10^5 \text{ N/mm}^2$

Modulus of rigidity,  $C = 4.8 \times 10^4 \text{ N/mm}^2$

Let the Poisson's ratio =  $\mu$

Using equation (2.16), we get

$$E = 2C (1 + \mu)$$

$$\text{or} \quad 1.2 \times 10^5 = 2 \times 4.8 \times 10^4 (1 + \mu)$$

$$\text{or} \quad (1 + \mu) = \frac{1.2 \times 10^5}{2 \times 4.8 \times 10^4} = 1.25 \quad \text{or} \quad \mu = 1.25 - 1.0 = \mathbf{0.25. \text{ Ans.}}$$

Bulk modulus is given by equation (2.10) as

$$\begin{aligned} K &= \frac{E}{3(1 - 2\mu)} = \frac{1.2 \times 10^5}{3(1 - 0.25 \times 2)} \\ &= \mathbf{8 \times 10^4 \text{ N/mm}^2. \text{ Ans.}} \quad (\because \mu = 0.25) \end{aligned}$$

**Problem 2.11.** A bar of cross-section  $8 \text{ mm} \times 8 \text{ mm}$  is subjected to an axial pull of  $7000 \text{ N}$ . The lateral dimension of the bar is found to be changed to  $7.9985 \text{ mm} \times 7.9985 \text{ mm}$ . If the modulus of rigidity of the material is  $0.8 \times 10^5 \text{ N/mm}^2$ , determine the Poisson's ratio and modulus of elasticity.

**Sol.** Given :

Area of section =  $8 \times 8 = 64 \text{ mm}^2$

Axial pull,  $P = 7000 \text{ N}$

Lateral dimensions =  $7.9985 \text{ mm} \times 7.9985 \text{ mm}$

Volume of  $C = 0.8 \times 10^5 \text{ N/mm}^2$

Let  $\mu$  = Poisson's ratio and  
 $E$  = Modulus of elasticity.

$$\begin{aligned} \text{Now lateral strain} &= \frac{\text{Change in lateral dimension}}{\text{Original lateral dimension}} \\ &= \frac{8 - 7.9985}{8} = \frac{0.0015}{8} = 0.0001875. \end{aligned}$$

To find the value of Poisson's ratio, we must know the value of longitudinal strain. But in this problem, the length of bar and the axial extension is not given. Hence longitudinal strain cannot be calculated. But axial stress can be calculated. Then longitudinal strain will be equal to axial stress divided by  $E$ .

$$\therefore \text{Axial stress, } \sigma = \frac{P}{\text{Area}} = \frac{7000}{64} = 109.375 \text{ N/mm}^2 \text{ and longitudinal strain} = \frac{\sigma}{E}$$

$$\text{But lateral strain} = \mu \times \text{longitudinal strain} = \mu \times \frac{\sigma}{E}$$

$$\text{or } 0.0001875 = \frac{\mu \times 109.375}{E} \quad (\because \text{Lateral strain} = 0.0001875)$$

$$\therefore \frac{E}{\mu} = \frac{109.375}{0.0001875} = 583333.33$$

$$\text{or } E = 583333.33\mu \quad \dots(i)$$

Using equation (2.17), we get

$$C = \frac{E}{2(1+\mu)} \quad \text{or } E = 2C(1+\mu)$$

$$= 2 \times 0.8 \times 10^5 (1+\mu) \quad (\because C = 0.8 \times 10^5)$$

$$\text{or } 583333.33\mu = 2 \times 0.8 \times 10^5 (1+\mu) \quad (\because E = 583333.33\mu)$$

$$\text{or } 1 + \mu = \frac{583333.33\mu}{2 \times 0.8 \times 10^5} = 3.6458\mu$$

$$\therefore 1 = 3.6458\mu - \mu = 2.6458\mu$$

$$\therefore \text{Poisson's ratio} = \mu = \frac{1}{2.6458} = 0.378. \quad \text{Ans.}$$

Modulus of elasticity ( $E$ ) is obtained by substituting the value of  $\mu$  in equation (i).

$$\therefore E = 583333.33\mu$$

$$\therefore E = \frac{583333.33}{2.6458} = 2.2047 \times 10^5 \text{ N/mm}^2. \quad \text{Ans.}$$

**Problem 2.12.** Calculate the modulus of rigidity and bulk modulus of a cylindrical bar of diameter 30 mm and of length 1.5 m if the longitudinal strain in a bar during a tensile stress is four times the lateral strain. Find the change in volume, when the bar is subjected to a hydrostatic pressure of 100 N/mm<sup>2</sup>. Take  $E = 1 \times 10^5 \text{ N/mm}^2$ .

**Sol. Given :**

$$\text{Dia. of bar, } d = 30 \text{ mm}$$

$$\text{Length of bar, } L = 1.5 \text{ m} = 1.5 \times 1000 = 1500 \text{ mm}$$

$$\therefore \text{Volume of bar, } V = \frac{\pi}{4} d^2 \times L = \frac{\pi}{4} \times 30 \times 1500$$

$$= 1060287.52 \text{ mm}^3$$

$$\text{Longitudinal strain} = 4 \times \text{Lateral strain}$$

$$\text{Hydrostatic pressure, } p = 100 \text{ N/mm}^2$$

$$\therefore \frac{\text{Lateral strain}}{\text{Longitudinal strain}} = \frac{1}{4} = 0.25$$

$$\text{or Poisson's ratio, } \mu = 0.25$$

$$\text{Let } C = \text{Modulus of rigidity}$$

$$K = \text{Bulk modulus}$$

$$E = \text{Young's modulus} = 1 \times 10^5 \text{ N/mm}^2$$

Using equation (2.16), we get

$$E = 2C(1 + \mu)$$

$$\text{or } 1 \times 10^5 = 2C(1 + 0.25)$$

$$\therefore C = \frac{1 \times 10^5}{2 \times 1.25} = 4 \times 10^4 \text{ N/mm}^2. \quad \text{Ans.}$$

For bulk modulus, using equation (2.11), we get

$$E = 3K(1 - 2\mu)$$

$$\text{or } 1 \times 10^5 = 3K(1 - 2 \times 0.25) \quad (\because \mu = 0.25)$$

$$\therefore K = \frac{1 \times 10^5}{3 \times 0.5} = 0.667 \times 10^5 \text{ N/mm}^2. \quad \text{Ans.}$$

Now using equation (2.9), we get

$$K = \frac{p}{\text{Volumetric strain}} = \frac{p}{\left(\frac{dV}{V}\right)}$$

where  $p = 100 \text{ N/mm}^2$

$$\therefore 0.667 \times 10^5 = \frac{100}{\left(\frac{dV}{V}\right)}$$

$$\text{or } \frac{dV}{V} = \frac{100}{0.667 \times 10^5} = 1.5 \times 10^{-3}$$

$$\therefore dV = V \times 1.5 \times 10^{-3} = 1060287.52 \times 1.5 \times 10^{-3}$$

$$= 1590.43 \text{ mm}^3. \quad \text{Ans.}$$

### HIGHLIGHTS

1. Poisson's ratio is the ratio of lateral strain to longitudinal strain. It is generally denoted by  $\mu$ .
2. The tensile longitudinal stress produces compressive lateral strains.
3. If a load acts in the direction of length of a rectangular bar, then longitudinal strain =  $\frac{\delta l}{l}$  and

$$\text{Lateral strain} = \frac{\delta b}{b} \quad \text{or} \quad \frac{\delta d}{d}$$

where  $\delta l$  = Change in length,

$\delta b$  = Change in width,

$\delta d$  = Change in depth.



4. The ratio of change in volume to original volume is known as volumetric strain.
5. Volumetric strain ( $e_v$ ) for a rectangular bar subjected to an axial load  $P$ , is given by

$$e_v = \frac{\delta l}{l} (1 - 2\mu).$$

6. Volumetric strain for a rectangular bar subjected to three mutually perpendicular stresses is given by,

$$e_v = \frac{1}{E} (\sigma_x + \sigma_y + \sigma_z)(1 - 2\mu)$$

where  $\sigma_x$ ,  $\sigma_y$  and  $\sigma_z$  are stresses in  $x$ ,  $y$  and  $z$  direction respectively.

7. Principle of complementary shear stresses states that a set of shear stresses across a plane is always accompanied by a set of balancing shear stresses (*i.e.*, of the same intensity) across the plane and normal to it.
8. Volumetric strain of a cylindrical rod, subjected to an axial tensile load is given by,

$$e_v = \text{Longitudinal strain} - 2 \times \text{strain of diameter}$$

$$= \frac{\delta l}{l} - 2 \frac{\delta d}{d}.$$

9. Bulk modulus  $K$  is given by,

$$K = \frac{\sigma}{\left(\frac{\delta V}{V}\right)}.$$

10. The relation between Young's modulus and bulk modulus is given by,

$$E = 3K(1 - 2\mu).$$

11. When an element is subjected to simple shear stresses then :
- The planes of maximum normal stresses are perpendicular to each other.
  - The planes of maximum normal stresses are inclined at an angle of  $45^\circ$  to the plane of pure shear.
  - One of the maximum normal stress is tensile while the other maximum normal stress is compressive.
  - The maximum normal stresses are of the same magnitude and are equal to the shear stress on the plane of pure shear.
12. The relation between modulus of elasticity and modulus of rigidity is given by

$$E = 2C(1 + \mu) \quad \text{or} \quad C = \frac{E}{2(1 + \mu)}.$$

### EXERCISE 2

#### (A) Theoretical Questions

- Define and explain the terms : Longitudinal strain, lateral strain and Poisson's ratio.
- Prove that the volumetric strain of a cylindrical rod which is subjected to an axial tensile load is equal to strain in the length minus twice the strain of diameter.
- What is a bulk modulus ? Derive an expression for Young's modulus in terms of bulk modulus and Poisson's ratio.
- Define volumetric strain. Prove that the volumetric strain for a rectangular bar subjected to an axial load  $P$  in the direction of its length is given by

$$e_v = \frac{\delta l}{l} (1 - 2\mu)$$

where  $\mu$  = Poisson's ratio and  $\frac{\delta l}{l}$  = Longitudinal strain.

- (a) Derive an expression for volumetric strain for a rectangular bar which is subjected to three mutually perpendicular tensile stresses.  
(b) A test element is subjected to three mutually perpendicular unequal stresses. Find the change in volume of the element, if the algebraic sum of these stresses is equal to zero.
- Explain briefly the term 'shear stress' and 'complimentary stress' with proper illustrations.
- State the principle of shear stress.
- What do you understand by 'An element in a state of simple shear' ?
- When an element is in a state of simple shear then prove that the planes of maximum normal stresses are perpendicular to each other and these planes are inclined at an angle of  $45^\circ$  to the planes of pure shear.
- Derive an expression between modulus of elasticity and modulus of rigidity.

#### (B) Numerical Problems

- Determine the changes in length, breadth and thickness of a steel bar which is 5 m long, 40 mm wide and 30 mm thick and is subjected to an axial pull of 35 kN in the direction of its length. Take  $E = 2 \times 10^5 \text{ N/mm}^2$  and Poisson's ratio = 0.32.  
[Ans. 0.0729 cm, 0.000186 cm, 0.000139 cm]
- For the above problem, determine the volumetric strain and the final volume of the given steel bar.  
[Ans. 0.0000525, 6000317 mm<sup>3</sup>]
- Determine the value of Young's modulus and Poisson's ratio of a metallic bar of length 25 cm, breadth 3 cm and depth 2 cm when the bar is subjected to an axial compressive load of 240 kN. The decrease in length is given as 0.05 cm and increase in breadth is 0.002.  
[Ans.  $2 \times 10^5 \text{ N/mm}^2$  and 0.33]
- A steel bar 320 mm long, 40 mm wide and 30 mm thick is subjected to a pull of 250 kN in the direction of its length. Determine the change in volume. Take  $E = 2 \times 10^5 \text{ N/mm}^2$  and  $m = 4$ .  
[Ans. 200 mm<sup>3</sup>]
- A metallic bar 250 mm  $\times$  80 mm  $\times$  30 mm is subjected to a force of 20 kN (tensile), 30 kN (tensile) and 15 kN (tensile) along  $x$ ,  $y$  and  $z$  directions respectively. Determine the change in the volume of the block. Take  $E = 2 \times 10^5 \text{ N/mm}^2$  and Poisson's ratio = 0.25.  
[Ans. 19.62 mm<sup>3</sup>]
- A metallic bar 300 mm  $\times$  120 mm  $\times$  50 mm is loaded as shown in Fig. 2.15. Find the change in volume. Take  $E = 2 \times 10^5 \text{ N/mm}^2$  and Poisson's ratio = 0.30.

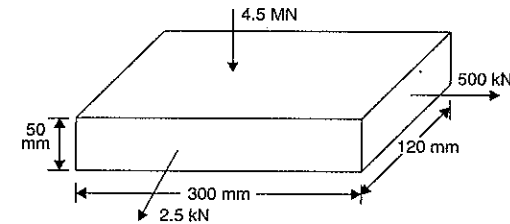

Fig. 2.15

- Also find the change that should be made in 4.5 MN load, in order that there should be no change in the volume of the bar.  
[Ans. 450 mm<sup>2</sup>, 4.5 MN]
- A steel rod 4 m long and 20 mm diameter is subjected to an axial tensile load of 40 kN. Determine the change in length, diameter and volume of the rod. Take  $E = 2 \times 10^5 \text{ N/mm}^2$  and Poisson's ratio = 0.25.  
[Ans. 2.5464, 0.05092, 5598 mm<sup>3</sup>]

8. For a material, Young's modulus is given as  $1.4 \times 10^5 \text{ N/mm}^2$  and Poisson's ratio 0.28. Calculate the bulk modulus. [Ans.  $1.06 \times 10^5 \text{ N/mm}^2$ ]
9. A bar of 20 mm diameter subjected to a pull of 50 kN. The measured extension on gauge length of 250 mm is 0.12 mm and change in diameter is 0.00375 mm. Calculate :  
 (i) Young's modulus (ii) Poisson's ratio and (iii) Bulk modulus.  
 [Ans. (i)  $1.989 \times 10^5 \text{ N/mm}^2$ , (ii) 0.234, (iii)  $1.2465 \times 10^5 \text{ N/mm}^2$ ]
10. Determine the Poisson's ratio and bulk modulus of a material, for which Young's modulus is  $1.2 \times 10^5 \text{ N/mm}^2$  and modulus of rigidity is  $4.5 \times 10^4 \text{ N/mm}^2$ . [Ans. 0.33,  $1.2 \times 10^5 \text{ N/mm}^2$ ]
11. A bar of cross-section 10 mm  $\times$  10 mm is subjected to an axial pull of 8000 N. The lateral dimension of the bar is found to be changed to 9.9985 mm  $\times$  9.9985 mm. If the modulus of rigidity of the material is  $0.8 \times 10^5 \text{ N/mm}^2$ , determine the Poisson's ratio and modulus of elasticity.  
 [Ans. 0.45,  $2.4 \times 10^5 \text{ N/mm}^2$ ]
12. Calculate the modulus of rigidity and bulk modulus of a cylindrical bar of diameter of 25 mm and of length 1.6 m, if the longitudinal strain in a bar during a tensile test is four times the lateral strain. Find the change in volume, when the bar is subjected to a hydrostatic pressure of  $100 \text{ N/mm}^2$ . Take  $E = 1 \times 10^5 \text{ N/mm}^2$ .  
 [Ans.  $4 \times 10^4 \text{ N/mm}^2$ ,  $0.667 \times 10^5 \text{ N/mm}^2$ ,  $1178 \text{ mm}^3$ ]
13. A bar 30 mm in diameter was subjected to tensile load of 54 kN and the measured extension on 300 mm gauge length was 0.112 mm and change in diameter was 0.00366 mm. Calculate Poisson's ratio and values of three moduli.  
 [Ans.  $\mu = 0.326$ ,  $E = 204.6 \text{ kN/mm}^2$ ,  $C = 77.2 \text{ kN/mm}^2$ ,  $K = 196 \text{ kN/mm}^2$ ]
14. Derive the relation between  $E$  and  $C$ . Using the derived relationship, estimate the Young's modulus ( $E$ ) when the modulus of rigidity ( $C$ ) is  $0.80 \times 10^5 \text{ N/mm}^2$  and the Poisson's ratio is 0.3.  
 [Hint.  $E = 2C(1 + \mu) = 2 \times 0.80 \times 10^5(1 + 0.3) = 2.08 \times 10^5 \text{ N/mm}^2$ .]

## 3

## Principal Stresses and Strains

## 3.1. INTRODUCTION

In chapter 2, the concept and definition of stress, strain, types of stresses (*i.e.*, tensile, compressive and simple shear) and types of strain (*i.e.*, tensile, compressive, shear and volumetric strains etc.) are discussed. These stresses were acting in a plane, which was at right angles to the line of action of the force. In many engineering problems both direct (tensile or compressive stress) and shear stresses are acting at the same time. In such situation the resultant stress across any section will be neither normal nor tangential to the plane. In this chapter the stresses, acting on an inclined plane (or oblique section) will be analysed.

## 3.2. PRINCIPAL PLANES AND PRINCIPAL STRESSES

The planes, which have no shear stress, are known as principal planes. Hence principal planes are the planes of zero shear stress. These planes carry only normal stresses.

The normal stresses, acting on a principal plane, are known as principal stresses.

## 3.3. METHODS FOR DETERMINING STRESSES ON OBLIQUE SECTION

The stresses on oblique section are determined by the following methods :

1. Analytical method, and
2. Graphical method.

## 3.4. ANALYTICAL METHOD FOR DETERMINING STRESSES ON OBLIQUE SECTION

The following two cases will be considered :

1. A member subjected to a direct stress in one plane.
2. The member is subjected to like direct stresses in two mutually perpendicular directions.

**3.4.1. A Member Subjected to a Direct Stress in one Plane.** Fig. 3.1 (a) shows a rectangular member of uniform cross-sectional area  $A$  and of unit thickness.

Let  $P$  = Axial force acting on the member.

$A$  = Area of cross-section, which is perpendicular to the line of action of the force  $P$ .

The stress along  $x$ -axis,  $\sigma = \frac{P}{A}$

Hence, the member is subjected to a stress along  $x$ -axis.

Consider a cross-section  $EF$  which is perpendicular to the line of action of the force  $P$ .

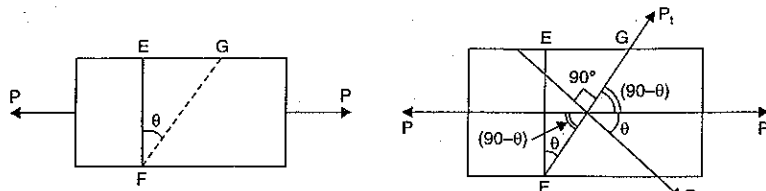

Fig. 3.1 (a)

Fig. 3.2 (b)

Then area of section,  $EF = EF \times 1 = A$ .

The stress on the section  $EF$  is given by

$$\sigma = \frac{\text{Force}}{\text{Area of } EF} = \frac{P}{A} \quad \dots(i)$$

The stress on the section  $EF$  is entirely normal stress. There is no shear stress (or tangential stress) on the section  $EF$ .

Now consider a section  $FG$  at an angle  $\theta$  with the normal cross-section  $EF$  as shown in Fig. 3.1 (a).

Area of section  $FG = FG \times 1$  (member is having unit thickness)

$$\begin{aligned} &= \frac{EF}{\cos \theta} \times 1 && \left( \because \text{In } \Delta EFG, \frac{EF}{FG} = \cos \theta \therefore FG = \frac{EF}{\cos \theta} \right) \\ &= \frac{A}{\cos \theta} && (\because EF \times 1 = A) \end{aligned}$$

$\therefore$  Stress on the section,  $FG$

$$\begin{aligned} &= \frac{\text{Force}}{\text{Area of section } FG} = \frac{P}{\left(\frac{A}{\cos \theta}\right)} = \frac{P}{A} \cos \theta \\ &= \sigma \cos \theta && \left( \because \frac{P}{A} = \sigma \right) \quad \dots(3.1) \end{aligned}$$

This stress, on the section  $FG$ , is parallel to the axis of the member (*i.e.*, this stress is along  $x$ -axis). This stress may be resolved in two components. One component will be normal to the section  $FG$  whereas the second component will be along the section  $FG$  (*i.e.*, tangential to the section  $FG$ ). The normal stress and tangential stress (*i.e.*, shear stress) on the section  $FG$  are obtained as given below [Refer to Fig. 3.1 (b)].

Let  $P_n$  = The component of the force  $P$ , normal to section  $FG$

$$= P \cos \theta$$

$P_t$  = The component of force  $P$ , along the surface of the section  $FG$  (or tangential to the surface  $FG$ )

$$= P \sin \theta$$

$\sigma_n$  = Normal stress across the section  $FG$

$\sigma_t$  = Tangential stress (*i.e.*, shear stress) across the section  $FG$ .

$\therefore$  Normal stress and tangential stress across the section  $FG$  are obtained as,

$$\begin{aligned} \text{Normal stress, } \sigma_n &= \frac{\text{Force normal to section } FG}{\text{Area of section } FG} \\ &= \frac{P_n}{\left(\frac{A}{\cos \theta}\right)} = \frac{P \cos \theta}{\left(\frac{A}{\cos \theta}\right)} && (\because P_n = P \cos \theta) \\ &= \frac{P}{A} \cos \theta \cdot \cos \theta = \frac{P}{A} \cos^2 \theta \\ &= \sigma \cos^2 \theta && \left( \because \frac{P}{A} = \sigma \right) \quad \dots(3.2) \end{aligned}$$

Tangential stress (*i.e.*, shear stress),

$$\begin{aligned} \sigma_t &= \frac{\text{Tangential force across section } FG}{\text{Area of section } FG} \\ &= \frac{P_t}{\left(\frac{A}{\cos \theta}\right)} = \frac{P \sin \theta}{\left(\frac{A}{\cos \theta}\right)} && (\because P_t = P \sin \theta) \\ &= \frac{P}{A} \sin \theta \cdot \cos \theta = \sigma \sin \theta \cdot \cos \theta \\ &= \frac{\sigma}{2} \times 2 \sin \theta \cos \theta && [\text{Multiplying and dividing by 2}] \\ &= \frac{\sigma}{2} \sin 2\theta && (\because 2 \sin \theta \cos \theta = \sin 2\theta) \quad \dots(3.3) \end{aligned}$$

From equation (3.2), it is seen that the normal stress ( $\sigma_n$ ) on the section  $FG$  will be maximum, when  $\cos^2 \theta$  or  $\cos \theta$  is maximum. And  $\cos \theta$  will be maximum when  $\theta = 0^\circ$  as  $\cos 0^\circ = 1$ . But when  $\theta = 0^\circ$ , the section  $FG$  will coincide with section  $EF$ . But the section  $EF$  is normal to the line of action of the loading. This means the plane normal to the axis of loading will carry the maximum normal stress.

$\therefore$  Maximum normal stress,  $= \sigma \cos^2 \theta = \sigma \cos^2 0^\circ = \sigma \quad \dots(3.4)$

From equation (3.3), it is observed that the tangential stress (*i.e.*, shear stress) across the section  $FG$  will be maximum when  $\sin 2\theta$  is maximum. And  $\sin 2\theta$  will be maximum when  $\sin 2\theta = 1$  or  $2\theta = 90^\circ$  or  $270^\circ$

or  $\theta = 45^\circ$  or  $135^\circ$ .

This means the shear stress will be maximum on two planes inclined at  $45^\circ$  and  $135^\circ$  to the normal section  $EF$  as shown in Figs. 3.1 (c) and 3.1 (d).

$\therefore$  Max. value of shear stress  $= \frac{\sigma}{2} \sin 2\theta = \frac{\sigma}{2} \sin 90^\circ = \frac{\sigma}{2} \quad \dots(3.5)$

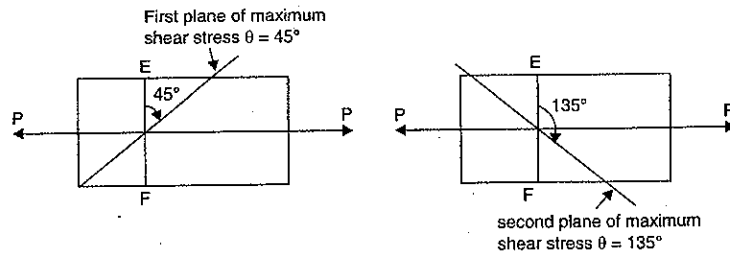

Fig. 3.1 (c)

Fig. 3.1 (d)

From equations (3.4) and (3.5) it is seen that maximum normal stress is equal to  $\sigma$  whereas the maximum shear stress is equal to  $\sigma/2$  or equal to half the value of greatest normal stress.

### Second Method

**A member subjected to a direct stress in one plane.** Fig. 3.2 shows a rectangular member of uniform cross-sectional area  $A$  and of unit thickness. The bar is subjected to a principal tensile stress  $\sigma_1$  on the faces  $AD$  and  $BC$ .

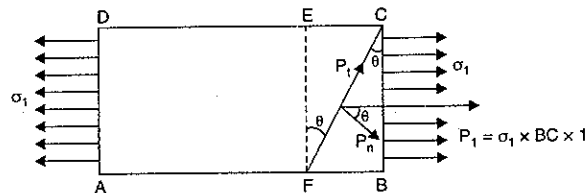

Fig. 3.2

$$\begin{aligned} \text{Area of cross-section} &= BC \times \text{Thickness of bar} \\ &= BC \times 1 \end{aligned}$$

Let the stresses on the oblique plane  $FC$  are to be calculated. The plane  $FC$  is inclined at an angle  $\theta$  with the normal cross-section  $EF$  (or  $BC$ ). This can be done by converting the stress  $\sigma_1$  acting on face  $BC$  into equivalent force. Then this force will be resolved along the inclined planes  $FC$  and perpendicular to  $FC$ . (Please note that it is force and not the stress which is to be resolved).

$$\begin{aligned} \text{Tensile stress on face } BC &= \sigma_1 \\ \text{Now, the tensile force on } BC, \end{aligned}$$

$$\begin{aligned} P_1 &= \text{Stress } (\sigma_1) \times \text{Area of cross-section} \\ &= \sigma_1 \times BC \times 1 \quad (\because \text{Area} = BC \times 1) \end{aligned}$$

The above tensile force  $P_1$  is also acting on the inclined section  $FC$ , in the axial direction as shown in Fig. 3.2. This force  $P_1$  is resolved into two components, i.e., one normal to the plane  $FC$  and other along the plane  $FC$ .

$$\begin{aligned} \text{Let } P_n &= \text{Component of the force } P_1, \text{ normal to the section } FC \\ &= P_1 \cos \theta \\ &= \sigma_1 \times BC \times 1 \times \cos \theta \quad (\because P_1 = \sigma_1 \times BC \times 1) \\ P_t &= \text{Component of the force } P_1, \text{ along the section } FC \\ &= P_1 \sin \theta \\ &= \sigma_1 \times BC \times 1 \times \sin \theta \\ \sigma_n &= \text{Normal stress on the section } FC \end{aligned}$$

$\sigma_t$  = Shear stress (or tangential stress) across the section  $FC$ .

$$\begin{aligned} \text{Then normal stress, } \sigma_n &= \frac{\text{Force normal to section } FC}{\text{Area of section } FC} \\ &= \frac{P_n}{FC \times 1} \quad (\because \text{bar is of unit thickness}) \\ &= \frac{\sigma_1 \times BC \times \cos \theta}{FC} \quad (\because P_n = \sigma_1 \times BC \times \cos \theta) \\ &= \sigma_1 \times \cos \theta \times \cos \theta \quad \left( \because \text{In triangle } FBC, \frac{BC}{FC} = \cos \theta \right) \\ &= \sigma_1 \times \cos^2 \theta \quad \dots(3.5A) \end{aligned}$$

Similarly, tangential (or shear) stress,

$$\begin{aligned} \sigma_t &= \frac{\text{Force along section } FC}{\text{Area of section } FC} = \frac{P_t}{FC \times 1} \\ &= \frac{\sigma_1 \times BC \times 1 \times \sin \theta}{FC} \quad (\because P_t = \sigma_1 \times BC \times 1) \\ &= \sigma_1 \times \cos \theta \times \sin \theta \quad \left( \because \text{In triangle } FBC, \frac{BC}{FC} = \cos \theta \right) \\ &= \sigma_1 \times \cos \theta \times \sin \theta \\ &= \frac{\sigma_1}{2} \times 2 \times \cos \theta \times \sin \theta \quad (\text{Multiplying and dividing by two}) \\ &= \frac{\sigma_1}{2} \times \sin 2\theta \quad \dots(3.5B) \quad (\because 2 \sin \theta \cos \theta = \sin 2\theta) \end{aligned}$$

From equation (3.5A), it is seen that the normal stress ( $\sigma_n$ ) on the section  $FC$  will be maximum, when  $\cos^2 \theta$  or  $\cos \theta$  is maximum. And  $\cos \theta$  will be maximum when  $\theta = 0^\circ$  as  $\cos 0^\circ = 1$ . But when  $\theta = 0^\circ$ , the section  $FC$  will coincide with section  $EF$ . But the section  $EF$  is normal to the line of action of the loading. This means the plane normal to the axis of loading will carry the maximum normal stress.

$$\therefore \text{Maximum normal stress} = \sigma_1 \cos^2 \theta = \sigma_1 \cos^2 0^\circ = \sigma_1 \quad \dots(3.5C)$$

From equation (3.5B), it is observed that the tangential stress (i.e., shear stress) across the section  $FC$  will be maximum when  $\sin 2\theta$  is maximum. And  $\sin 2\theta$  will be maximum when  $\sin 2\theta = 1$  or  $2\theta = 90^\circ$  or  $270^\circ$  or  $\theta = 45^\circ$  or  $135^\circ$ .

This means the shear stress will be maximum on two planes inclined at  $45^\circ$  and  $135^\circ$  to the normal section  $EF$  or  $BC$  as shown in Figs. 3.2 (a) and 3.2 (b).

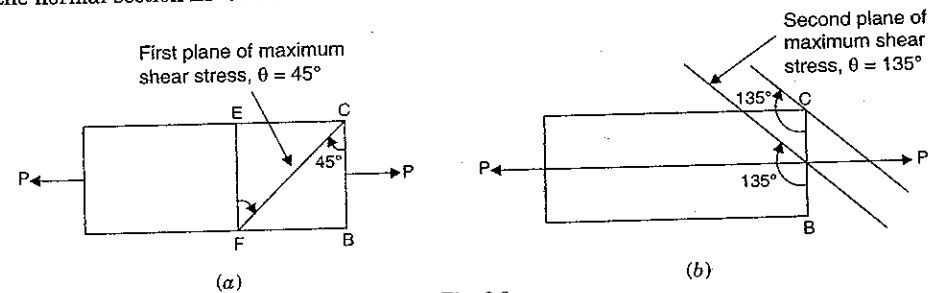

Fig. 3.2

$$\therefore \text{Max. value of shear stress} = \frac{\sigma_1}{2} \sin 2\theta = \frac{\sigma_1}{2} \sin 90^\circ = \frac{\sigma_1}{2} \quad \dots(3.5D)$$

From equations (3.5C) and (3.5D) it is seen that maximum normal stress is equal to  $\sigma_1$

whereas the maximum shear stress is equal to  $\frac{\sigma_1}{2}$  or equal to half the value of greatest normal stress.

**Note.** It is the force which is resolved in two components. The stress is not resolved.

**Problem 3.1.** A rectangular bar of cross-sectional area  $10000 \text{ mm}^2$  is subjected to an axial load of  $20 \text{ kN}$ . Determine the normal and shear stresses on a section which is inclined at an angle of  $30^\circ$  with normal cross-section of the bar.

**Sol. Given :**

Cross-sectional area of the rectangular bar,

$$A = 10000 \text{ mm}^2$$

Axial load,  $P = 20 \text{ kN} = 20,000 \text{ N}$

Angle of oblique plane with the normal cross-section of the bar,

$$\theta = 30^\circ$$

$$\text{Now direct stress, } \sigma = \frac{P}{A} = \frac{20000}{10000} = 2 \text{ N/mm}^2$$

Let  $\sigma_n =$  Normal stress on the oblique plane  
 $\sigma_t =$  Shear stress on the oblique plane.

Using equation (3.2) for normal stress, we get

$$\begin{aligned} \sigma_n &= \sigma \cos^2 \theta \\ &= 2 \times \cos^2 30^\circ & (\because \sigma = 2 \text{ N/mm}^2) \\ &= 2 \times 0.866^2 & (\because \cos 30^\circ = 0.866) \\ &= 1.5 \text{ N/mm}^2. \quad \text{Ans.} \end{aligned}$$

Using equation (3.3) for shear stress, we get

$$\begin{aligned} \sigma_t &= \frac{\sigma}{2} \sin 2\theta = \frac{2}{2} \times \sin (2 \times 30^\circ) \\ &= 1 \times \sin 60^\circ = 0.866 \text{ N/mm}^2. \quad \text{Ans.} \end{aligned}$$

**Problem 3.2.** Find the diameter of a circular bar which is subjected to an axial pull of  $160 \text{ kN}$ , if the maximum allowable shear stress on any section is  $65 \text{ N/mm}^2$ .

**Sol. Given :**

Axial pull,  $P = 160 \text{ kN} = 160000 \text{ N}$

Maximum shear stress =  $65 \text{ N/mm}^2$

Let  $D =$  Diameter of the bar

$$\therefore \text{Area of the bar} = \frac{\pi}{4} D^2$$

$$\therefore \text{Direct stress, } \sigma = \frac{P}{A} = \frac{160000}{\frac{\pi}{4} D^2} = \frac{640000}{\pi D^2} \text{ N/mm}^2$$

Maximum shear stress is given by equation (3.5).

$$\therefore \text{Maximum shear stress} = \frac{\sigma}{2} = \frac{640000}{2 \times \pi D^2}$$

But maximum shear stress is given as  $= 65 \text{ N/mm}^2$ .

Hence equating the two values of maximum shear, we get

$$\therefore 65 = \frac{640000}{2 \times \pi D^2}$$

$$\therefore D^2 = \frac{640000}{2 \times \pi \times 65} = 1567$$

$$\therefore D = 39.58 \text{ mm.} \quad \text{Ans.}$$

**Problem 3.3.** A rectangular bar of cross-sectional area of  $11000 \text{ mm}^2$  is subjected to a tensile load  $P$  as shown in Fig. 3.3. The permissible normal and shear stresses on the oblique plane  $BC$  are given as  $7 \text{ N/mm}^2$  and  $3.5 \text{ N/mm}^2$  respectively. Determine the safe value of  $P$ .

**Sol. Given :**

Area of cross-section,  $A = 11000 \text{ mm}^2$

Normal stress,  $\sigma_n = 7 \text{ N/mm}^2$

Shear stress,  $\sigma_t = 3.5 \text{ N/mm}^2$

Angle of oblique plane with the axis of bar =  $60^\circ$ .

$\therefore$  Angle of oblique plane  $BC$  with the normal cross-section of the bar,

$$\theta = 90^\circ - 60^\circ = 30^\circ$$

Let  $P =$  Safe value of axial pull

$\sigma =$  Safe stress in the member.

Using equation (3.2),

$$\begin{aligned} \sigma_n &= \sigma \cos^2 \theta \quad \text{or} \quad 7 = \sigma \cos^2 30^\circ \\ &= \sigma (0.866)^2. & (\because \cos 30^\circ = 0.866) \end{aligned}$$

$$\therefore \sigma = \frac{7}{0.866 \times 0.866} = 9.334 \text{ N/mm}^2$$

Using equation (3.3),

$$\sigma_t = \frac{\sigma}{2} \sin 2\theta$$

or

$$3.5 = \frac{\sigma}{2} \sin 2 \times 30^\circ = \frac{\sigma}{2} \sin 60^\circ = \frac{\sigma}{2} \times 0.866$$

$$\therefore \sigma = \frac{3.5 \times 2}{0.866} = 8.083 \text{ N/mm}^2.$$

The safe stress is the least of the two, i.e.,  $8.083 \text{ N/mm}^2$ .

$\therefore$  Safe value of axial pull,

$$\begin{aligned} P &= \text{Safe stress} \times \text{Area of cross-section} \\ &= 8.083 \times 11000 = 88913 \text{ N} = 88.913 \text{ kN.} \quad \text{Ans.} \end{aligned}$$

**Problem 3.4.** Two wooden pieces  $10 \text{ cm} \times 10 \text{ cm}$  in cross-section are glued together along line  $AB$  as shown in Fig. 3.3(a) below. What maximum axial force  $P$  can be applied if the allowable shearing stress along  $AB$  is  $1.2 \text{ N/mm}^2$ ? (AMIE, Summer 1987)

**Sol. Given :**

Area of cross-section =  $10 \times 10 = 100 \text{ cm}^2$

$$= 100 \times 100 \text{ mm}^2 = 10000 \text{ mm}^2$$

Allowable shear stress,  $\sigma_t = 1.2 \text{ N/mm}^2$

Angle of line  $AB$  with the axis of axial force =  $30^\circ$

$\therefore$  Angle of line  $AB$  with the normal cross-section,

$$\theta = 90^\circ - 30^\circ = 60^\circ$$

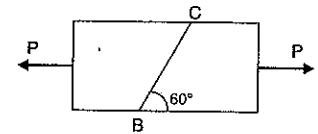

Fig. 3.3

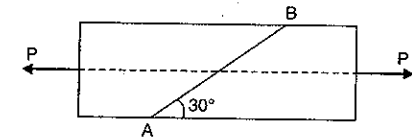

Fig. 3.3 (a)

Let  $P$  = Maximum axial force  
 $\sigma$  = Maximum allowable stress in the direction of  $P$ .

Using equation (3.3),

$$\sigma_t = \frac{\sigma}{2} \sin 2\theta$$

or  $1.2 = \frac{\sigma}{2} \times \sin (2 \times 60^\circ) = \frac{\sigma}{2} \times \sin 120^\circ$

$$\therefore \sigma = \frac{1.2 \times 2}{\sin 120^\circ} = \frac{2.4}{0.866} = 2.771 \text{ N/mm}^2$$

$\therefore$  Maximum axial force,

$$P = \text{Stress in the direction of } P \times \text{Area of cross-section} \\ = \sigma \times 10000 = 2.771 \times 10000 = 27710 \text{ N} = 27.71 \text{ kN. Ans.}$$

**3.4.2. A Member Subjected to like Direct Stresses in two Mutually Perpendicular Directions.** Fig. 3.4 (a) shows a rectangular bar  $ABCD$  of uniform cross-sectional area  $A$  and of unit thickness. The bar is subjected to two direct tensile stresses (or two-principal tensile stresses) as shown in Fig. 3.4 (a).

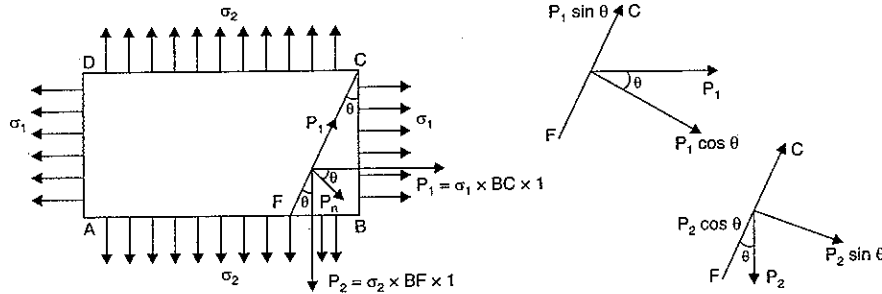

Fig. 3.4 (a)

Let  $FC$  be the oblique section on which stresses are to be calculated. This can be done by converting the stresses  $\sigma_1$  (acting on face  $BC$ ) and  $\sigma_2$  (acting on face  $AB$ ) into equivalent forces. Then these forces will be resolved along the inclined plane  $FC$  and perpendicular to  $FC$ . Consider the forces acting on wedge  $FBC$ .

Let  $\theta$  = Angle made by oblique section  $FC$  with normal cross-section  $BC$   
 $\sigma_1$  = Major tensile stress on face  $AD$  and  $BC$   
 $\sigma_2$  = Minor tensile stress on face  $AB$  and  $CD$   
 $P_1$  = Tensile force on face  $BC$   
 $P_2$  = Tensile force on face  $FB$ .

The tensile force on face  $BC$ ,

$$P_1 = \sigma_1 \times \text{Area of face } BC = \sigma_1 \times BC \times 1 \quad (\because \text{Area} = BC \times 1)$$

The tensile force on face  $FB$ ,

$$P_2 = \text{Stress on } FB \times \text{Area of } FB = \sigma_2 \times FB \times 1.$$

The tensile forces  $P_1$  and  $P_2$  are also acting on the oblique section  $FC$ . The force  $P_1$  is acting in the axial direction, whereas the force  $P_2$  is acting downwards as shown in Fig. 3.4 (a). Two forces  $P_1$  and  $P_2$  each can be resolved into two components *i.e.*, one normal to the plane  $FC$  and other along the plane  $FC$ . The components of  $P_1$  are  $P_1 \cos \theta$  normal to the plane  $FC$  and  $P_1 \sin \theta$  along the plane in the upward direction. The components of  $P_2$  are  $P_2 \sin \theta$  normal to the plane  $FC$  and  $P_2 \cos \theta$  along the plane in the downward direction.

Let  $P_n$  = Total force normal to section  $FC$   
 = Component of force  $P_1$  normal to section  $FC$   
 + Component of force  $P_2$  normal to section  $FC$

$$= P_1 \cos \theta + P_2 \sin \theta$$

$$= \sigma_1 \times BC \times \cos \theta + \sigma_2 \times BF \times \sin \theta \quad (\because P_1 = \sigma_1 \times BC, P_2 = \sigma_2 \times BF)$$

$P_t$  = Total force along the section  $FC$

$$= \text{Component of force } P_1 \text{ along the section } FC$$

$$+ \text{Component of force } P_2 \text{ along the section } FC$$

$$= P_1 \sin \theta + (-P_2 \cos \theta) \quad (-\text{ve sign is taken due to opposite direction})$$

$$= P_1 \sin \theta - P_2 \cos \theta$$

$$= \sigma_1 \times BC \times \sin \theta - \sigma_2 \times BF \times \cos \theta$$

(Substituting the values  $P_1$  and  $P_2$ )

$\sigma_n$  = Normal stress across the section  $FC$

$$= \frac{\text{Total force normal to the section } FC}{\text{Area of section } FC}$$

$$= \frac{P_n}{FC \times 1} = \frac{\sigma_1 \times BC \times \cos \theta + \sigma_2 \times BF \times \sin \theta}{FC}$$

$$= \sigma_1 \times \frac{BC}{FC} \times \cos \theta + \sigma_2 \times \frac{BF}{FC} \times \sin \theta$$

$$= \sigma_1 \times \cos \theta \times \cos \theta + \sigma_2 \times \sin \theta \times \sin \theta$$

$$\left( \because \text{In triangle } FBC, \frac{BC}{FC} = \cos \theta, \frac{BF}{FC} = \sin \theta \right)$$

$$= \sigma_1 \cos^2 \theta + \sigma_2 \sin^2 \theta$$

$$= \sigma_1 \left( \frac{1 + \cos 2\theta}{2} \right) + \sigma_2 \left( \frac{1 - \cos 2\theta}{2} \right) **$$

$$[\because \cos^2 \theta = (1 + \cos 2\theta)/2 \text{ and } \sin^2 \theta = (1 - \cos 2\theta)/2]$$

$$= \frac{\sigma_1 + \sigma_2}{2} + \frac{\sigma_1 - \sigma_2}{2} \cos 2\theta \quad \dots(3.6)$$

$\sigma_t$  = Tangential stress (or shear stress) along section  $FC$

$$= \frac{\text{Total force along the section } FC}{\text{Area of section } FC} \quad \left( \because \text{Stress} = \frac{\text{Force}}{\text{Area}} \right)$$

$$* \cos 2\theta = \cos^2 \theta - \sin^2 \theta$$

$$= \cos^2 \theta - (1 - \cos^2 \theta) = 2 \cos^2 \theta - 1$$

$$\therefore \cos^2 \theta = \frac{(1 + \cos 2\theta)}{2}$$

$$** \cos 2\theta = \cos^2 \theta - \sin^2 \theta$$

$$= (1 - \sin^2 \theta) - \sin^2 \theta = 1 - 2 \sin^2 \theta$$

$$\therefore \sin^2 \theta = \frac{(1 - \cos 2\theta)}{2}$$

$$\begin{aligned}
 &= \frac{P_t}{FC \times 1} = \frac{\sigma_1 \times BC \times \sin \theta - \sigma_2 \times BF \times \cos \theta}{FC} \\
 &= \sigma_1 \times \frac{BC}{FC} \times \sin \theta - \sigma_2 \times \frac{BF}{FC} \times \cos \theta \\
 &= \sigma_1 \times \cos \theta \times \sin \theta - \sigma_2 \times \sin \theta \times \cos \theta \\
 &\quad \left( \because \text{In triangle } FBC, \frac{BC}{FC} = \cos \theta, \frac{BF}{FC} = \sin \theta \right) \\
 &= (\sigma_1 - \sigma_2) \cos \theta \sin \theta \\
 &= \frac{(\sigma_1 - \sigma_2)}{2} \times 2 \cos \theta \sin \theta \quad \text{(Multiplying and dividing by 2)} \\
 &= \frac{(\sigma_1 - \sigma_2)}{2} \sin 2\theta \quad \dots(3.7)
 \end{aligned}$$

The resultant stress on the section  $FC$  will be given as

$$\sigma_R = \sqrt{\sigma_n^2 + \sigma_t^2} \quad \dots(3.8)$$

**Obliquity** [Refer to Fig. 3.4 (b)]. The angle made by the resultant stress with the normal of the oblique plane, is known as obliquity. It is denoted by  $\phi$ . Mathematically,

$$\tan \phi = \frac{\sigma_t}{\sigma_n} \quad \dots[3.8 (A)]$$

**Maximum shear stress.** The shear stress is given by equation (3.7). The shear stress ( $\sigma_t$ ) will be maximum when

$$\sin 2\theta = 1 \text{ or } 2\theta = 90^\circ \text{ or } 270^\circ \quad (\because \sin 90^\circ = 1 \text{ and also } \sin 270^\circ = 1)$$

or

$$\theta = 45^\circ \text{ or } 135^\circ$$

And maximum shear stress,  $(\sigma_t)_{max} = \frac{\sigma_1 - \sigma_2}{2} \quad \dots(3.9)$

The planes of maximum shear stress are obtained by making an angle of  $45^\circ$  and  $135^\circ$  with the plane  $BC$  (at any point on the plane  $BC$ ) in such a way that the planes of maximum shear stress lie within the material as shown in Fig. 3.4 (c).

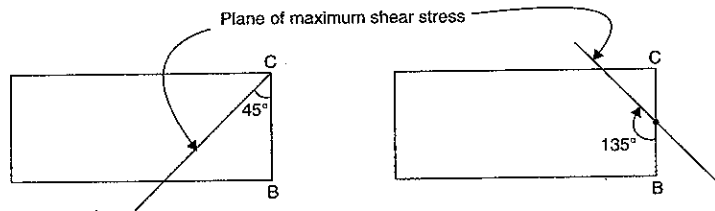

Fig. 3.4 (c)

Hence the planes, which are at an angle of  $45^\circ$  or  $135^\circ$  with the normal cross-section  $BC$  [see Fig. 3.4 (c)], carry the maximum shear stresses.

**Principal planes.** Principal planes are the planes on which shear stress is zero. To locate the position of principal planes, the shear stress given by equation (3.7) should be equated to zero.

$\therefore$  For principal planes,

$$\frac{\sigma_1 - \sigma_2}{2} \sin 2\theta = 0$$

or  $\sin 2\theta = 0 \quad [\because (\sigma_1 - \sigma_2) \text{ cannot be equal to zero}]$

or  $2\theta = 0 \text{ or } 180^\circ$

$\therefore \theta = 0 \text{ or } 90^\circ$

when  $\theta = 0$ ,

$$\begin{aligned}
 \sigma_n &= \frac{\sigma_1 + \sigma_2}{2} + \frac{\sigma_1 - \sigma_2}{2} \cos 2\theta \\
 &= \frac{\sigma_1 + \sigma_2}{2} + \frac{\sigma_1 - \sigma_2}{2} \cos 0^\circ \\
 &= \frac{\sigma_1 + \sigma_2}{2} + \frac{\sigma_1 - \sigma_2}{2} \times 1 \quad (\because \cos 0^\circ = 1) \\
 &= \sigma_1
 \end{aligned}$$

when  $\theta = 90^\circ$ ,

$$\begin{aligned}
 \sigma_n &= \frac{\sigma_1 + \sigma_2}{2} + \frac{\sigma_1 - \sigma_2}{2} \cos 2 \times 90^\circ \\
 &= \frac{\sigma_1 + \sigma_2}{2} + \frac{\sigma_1 - \sigma_2}{2} \cos 180^\circ \\
 &= \frac{\sigma_1 + \sigma_2}{2} + \frac{\sigma_1 - \sigma_2}{2} \times (-1) \quad (\because \cos 180^\circ = -1) \\
 &= \sigma_2.
 \end{aligned}$$

**Note.** The relations, given by equations (3.6) to (3.9), also hold good when one or both the stresses are compressive.

**Problem 3.5.** The tensile stresses at a point across two mutually perpendicular planes are  $120 \text{ N/mm}^2$  and  $60 \text{ N/mm}^2$ . Determine the normal, tangential and resultant stresses on a plane inclined at  $30^\circ$  to the axis of the minor stress.

**Sol.** Given :

Major principal stress,  $\sigma_1 = 120 \text{ N/mm}^2$

Minor principal,  $\sigma_2 = 60 \text{ N/mm}^2$

Angle of oblique plane with the axis of minor principal stress,

$$\theta = 30^\circ.$$

**Normal stress**

The normal stress ( $\sigma_n$ ) is given by equation (3.6),

$$\begin{aligned}
 \therefore \sigma_n &= \frac{\sigma_1 + \sigma_2}{2} + \frac{\sigma_1 - \sigma_2}{2} \cos 2\theta \\
 &= \frac{120 + 60}{2} + \frac{120 - 60}{2} \cos 2 \times 30^\circ \\
 &= 90 + 30 \cos 60^\circ = 90 + 30 \times \frac{1}{2} \\
 &= 105 \text{ N/mm}^2. \text{ Ans.}
 \end{aligned}$$

**Tangential stress**

The tangential (or shear stress)  $\sigma_t$  is given by equation (3.7).

$$\begin{aligned}\therefore \sigma_t &= \frac{\sigma_1 - \sigma_2}{2} \sin 2\theta \\ &= \frac{120 - 60}{2} \sin (2 \times 30^\circ) \\ &= 30 \times \sin 60^\circ = 30 \times 0.866 \\ &= \mathbf{25.98 \text{ N/mm}^2. \text{ Ans.}}\end{aligned}$$

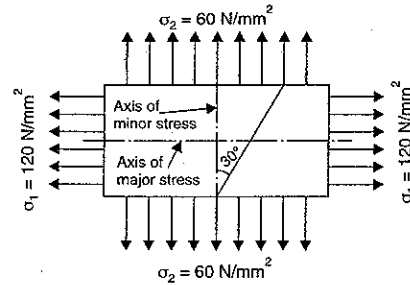

Fig. 3.5

**Resultant stress**

The resultant stress ( $\sigma_R$ ) is given by equation (3.8)

$$\begin{aligned}\therefore \sigma_R &= \sqrt{\sigma_n^2 + \sigma_t^2} = \sqrt{105^2 + 25.98^2} \\ &= \sqrt{11025 + 674.96} = \mathbf{108.16 \text{ N/mm}^2. \text{ Ans.}}\end{aligned}$$

**Problem 3.6.** The stresses at a point in a bar are  $200 \text{ N/mm}^2$  (tensile) and  $100 \text{ N/mm}^2$  (compressive). Determine the resultant stress in magnitude and direction on a plane inclined at  $60^\circ$  to the axis of the major stress. Also determine the maximum intensity of shear stress in the material at the point. (AMIE, Winter 1984)

**Sol. Given :**

Major principal stress,  $\sigma_1 = 200 \text{ N/mm}^2$

Minor principal stress,  $\sigma_2 = -100 \text{ N/mm}^2$

(Minus sign is due to compressive stress)

Angle of the plane, which it makes with the major principal stress =  $60^\circ$

$\therefore$  Angle  $\theta = 90^\circ - 60^\circ = 30^\circ$ .

**Resultant stress in magnitude and direction**

First calculate the normal and tangential stresses.

Using equation (3.6) for normal stress,

$$\begin{aligned}\sigma_n &= \frac{\sigma_1 + \sigma_2}{2} + \frac{\sigma_1 - \sigma_2}{2} \cos 2\theta \\ &= \frac{200 + (-100)}{2} + \frac{200 - (-100)}{2} \cos (2 \times 30^\circ) \\ &= \frac{200 - 100}{2} + \frac{200 + 100}{2} \cos 60^\circ \\ &= 50 + 150 \times \frac{1}{2} \quad (\because \cos 60^\circ = \frac{1}{2}) \\ &= 50 + 75 = \mathbf{125 \text{ N/mm}^2.}\end{aligned}$$

Using equation (3.7) for tangential stress,

$$\begin{aligned}\sigma_t &= \frac{\sigma_1 - \sigma_2}{2} \sin 2\theta = \frac{200 - (-100)}{2} \sin (2 \times 30^\circ) \\ &= \frac{200 + 100}{2} \sin 60^\circ = 150 \times 0.866 = \mathbf{129.9 \text{ N/mm}^2.}\end{aligned}$$

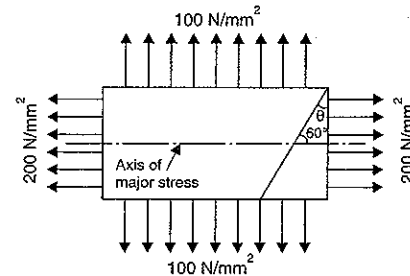

Fig. 3.6

Using equation (3.8) for resultant stress,

$$\begin{aligned}\sigma_R &= \sqrt{\sigma_n^2 + \sigma_t^2} = \sqrt{125^2 + 129.9^2} \\ &= \sqrt{15625 + 16874} = \mathbf{180.27 \text{ N/mm}^2. \text{ Ans.}}\end{aligned}$$

The inclination of the resultant stress with the normal of the inclined plane is given by equation [3.8 (A)] as

$$\begin{aligned}\tan \phi &= \frac{\sigma_t}{\sigma_n} = \frac{129.9}{125} = 1.04 \\ \therefore \phi &= \tan^{-1} 1.04 = \mathbf{46^\circ 6'. \text{ Ans.}}\end{aligned}$$

**Maximum shear stress**

Maximum shear stress is given by equation (3.9)

$$\therefore (\sigma_t)_{\max} = \frac{\sigma_1 - \sigma_2}{2} = \frac{200 - (-100)}{2} = \frac{200 + 100}{2} = \mathbf{150 \text{ N/mm}^2. \text{ Ans.}}$$

**Problem 3.7.** At a point in a strained material the principal tensile stresses across two perpendicular planes, are  $80 \text{ N/mm}^2$  and  $40 \text{ N/mm}^2$ . Determine normal stress, shear stress and the resultant stress on a plane inclined at  $20^\circ$  with the major principal plane. Determine also the obliquity. What will be the intensity of stress, which acting alone will produce the same maximum strain if Poisson's ratio =  $\frac{1}{4}$ .

**Sol. Given :**

Major principal stress,  $\sigma_1 = 80 \text{ N/mm}^2$

Minor principal stress,  $\sigma_2 = 40 \text{ N/mm}^2$

The plane  $CE$  is inclined at angle  $20^\circ$  with major principal plane (i.e., plane  $BC$ ).

$\therefore \theta = 20^\circ$

Poisson's ratio,  $\mu = \frac{1}{4}$

Let  $\sigma_n$  = Normal stress on inclined plane  $CE$

$\sigma_t$  = Shear stress and

$\sigma_R$  = Resultant stress.

Using equation (3.6), we get

$$\begin{aligned}\sigma_n &= \frac{\sigma_1 + \sigma_2}{2} + \frac{\sigma_1 - \sigma_2}{2} \cos 2\theta = \frac{80 + 40}{2} + \frac{80 - 40}{2} \cos (2 \times 20^\circ) \\ &= 60 + 20 \times \cos 40^\circ = \mathbf{75.32 \text{ N/mm}^2. \text{ Ans.}}\end{aligned}$$

The shear stress is given by equation (3.7)

$$\begin{aligned}\therefore \sigma_t &= \frac{\sigma_1 - \sigma_2}{2} \sin 2\theta = \frac{80 - 40}{2} \sin (2 \times 20^\circ) = 20 \sin 40^\circ \\ &= \mathbf{12.865 \text{ N/mm}^2. \text{ Ans.}}\end{aligned}$$

The resultant stress is given by equation (3.8)

$$\begin{aligned}\therefore \sigma_R &= \sqrt{\sigma_n^2 + \sigma_t^2} \\ &= \sqrt{75.32^2 + 12.865^2} = \mathbf{76.4 \text{ N/mm}^2. \text{ Ans.}}\end{aligned}$$

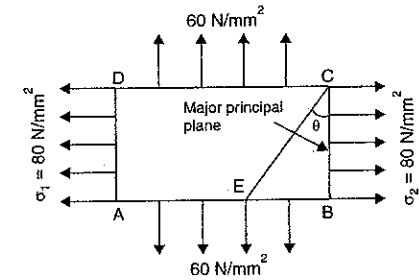

Fig. 3.7



Obliquity ( $\phi$ ) is given by equation [3.8 (A)]

$$\tan \phi = \frac{\sigma_t}{\sigma_n} = \frac{12.856}{75.32}$$

$$\therefore \phi = \tan^{-1} \frac{12.856}{75.32} = 9^\circ 41' \quad \text{Ans.}$$

Let  $\sigma$  = stress which acting alone will produce the same maximum strain. The maximum strain will be in the direction of major principal stress.

$$\begin{aligned} \therefore \text{Maximum strain} &= \frac{\sigma_1}{E} - \frac{\mu\sigma_2}{E} = \frac{1}{E}(\sigma_1 - \mu\sigma_2) \\ &= \frac{1}{E} \left( 80 - \frac{40}{4} \right) = \frac{70}{E} \end{aligned}$$

The strain due to stress  $\sigma = \frac{\sigma}{E}$

Equating the two strains, we get  $\frac{70}{E} = \frac{\sigma}{E}$

$$\therefore \sigma = 70 \text{ N/mm}^2 \quad \text{Ans.}$$

**Problem 3.8.** At a point in a strained material the principal stresses are 100 N/mm<sup>2</sup> (tensile) and 60 N/mm<sup>2</sup> (compressive). Determine the normal stress, shear stress and resultant stress on a plane inclined at 50° to the axis of major principal stress. Also determine the maximum shear stress at the point. (AMIE, Summer 1982)

**Sol.** Given :

Major principal stress,  $\sigma_1 = 100 \text{ N/mm}^2$

Minor principal stress,  $\sigma_2 = -60 \text{ N/mm}^2$  (Negative sign due to compressive stress)

Angle of the inclined plane with the axis of major principal stress = 50°

$\therefore$  Angle of the inclined plane with the axis of minor principal stress,

$$\theta = 90 - 50 = 40^\circ.$$

Normal stress ( $\sigma_n$ )

Using equation (3.6),

$$\begin{aligned} \sigma_n &= \frac{\sigma_1 + \sigma_2}{2} + \frac{\sigma_1 - \sigma_2}{2} \cos 2\theta \\ &= \frac{100 + (-60)}{2} + \frac{100 - (-60)}{2} \cos (2 \times 40^\circ) \\ &= \frac{100 - 60}{2} + \frac{100 + 60}{2} \cos 80^\circ \\ &= 20 + 80 \times \cos 80^\circ = 20 + 80 \times .1736 \\ &= 20 + 13.89 = 33.89 \text{ N/mm}^2 \quad \text{Ans.} \end{aligned}$$

Shear stress ( $\sigma_t$ )

Using equation (3.7),  $\sigma_t = \frac{\sigma_1 - \sigma_2}{2} \sin 2\theta$

$$= \frac{100 - (-60)}{2} \sin (2 \times 40^\circ)$$

$$= \frac{100 + 60}{2} \sin 80^\circ = 80 \times 0.9848 = 78.785 \text{ N/mm}^2 \quad \text{Ans.}$$

Resultant stress ( $\sigma_R$ )

Using equation on (3.8),

$$\begin{aligned} \sigma_R &= \sqrt{\sigma_n^2 + \sigma_t^2} = \sqrt{33.89^2 + 78.785^2} \\ &= \sqrt{1148.53 + 6207.07} = 85.765 \text{ N/mm}^2 \quad \text{Ans.} \end{aligned}$$

Maximum shear stress

Using equation (3.9),

$$(\sigma_t)_{\max} = \frac{\sigma_1 - \sigma_2}{2} = \frac{100 - (-60)}{2}$$

$$= \frac{100 + 60}{2} = 80 \text{ N/mm}^2 \quad \text{Ans.}$$

**Problem 3.9.** At a point in a strained material, the principal stresses are 100 N/mm<sup>2</sup> tensile and 40 N/mm<sup>2</sup> compressive. Determine the resultant stress in magnitude and direction on a plane inclined at 60° to the axis of the major principal stress. What is the maximum intensity of shear stress in the material at the point? (AMIE, Winter 1982)

**Sol.** Given :

The major principal stress,  $\sigma_1 = 100 \text{ N/mm}^2$

The minor principal stress,  $\sigma_2 = -40 \text{ N/mm}^2$  (Minus sign due to compressive stress)

Inclination of the plane with the axis of major principal stress = 60°

$\therefore$  Inclination of the plane with the axis of minor principal stress,

$$\theta = 90 - 60 = 30^\circ.$$

Resultant stress in magnitude

The resultant stress ( $\sigma_R$ ) is given by equation (3.8) as

$$\sigma_R = \sqrt{\sigma_n^2 + \sigma_t^2}$$

where  $\sigma_n$  = Normal stress and is given by equation (3.6) as

$$\begin{aligned} &= \frac{\sigma_1 + \sigma_2}{2} + \frac{\sigma_1 - \sigma_2}{2} \cos 2\theta \\ &= \frac{100 + (-40)}{2} + \frac{100 - (-40)}{2} \cos (2 \times 30^\circ) \end{aligned}$$

$$= \frac{100 - 40}{2} + \frac{100 + 40}{2} \cos 60^\circ$$

$$= 30 + 70 \times 0.5$$

$$= 65 \text{ N/mm}^2$$

$$(\because \cos 60^\circ = 0.5)$$

and  $\sigma_t$  = Shear stress and is given by equation (3.7) as

$$= \frac{\sigma_1 - \sigma_2}{2} \sin 2\theta = \frac{100 - (-40)}{2} \sin (2 \times 30^\circ)$$

$$= \frac{100 + 40}{2} \sin 60^\circ = 70 \times .866 = 60.62 \text{ N/mm}^2$$

$$\sigma_R = \sqrt{65^2 + 60.62^2} = 88.9 \text{ N/mm}^2. \text{ Ans.}$$

Direction of resultant stress

Let the resultant stress is inclined at an angle  $\phi$  to the normal of the oblique plane. Then using equation [3.8 (A)].

$$\tan \phi = \frac{\sigma_t}{\sigma_n} = \frac{60.62}{65}$$

$$\therefore \phi = \tan^{-1} \frac{60.62}{65} = 43^\circ. \text{ Ans.}$$

Maximum shear stress

$$\text{Using equation (3.9), } (\sigma_t)_{\max} = \frac{\sigma_1 - \sigma_2}{2}$$

$$= \frac{100 - (-40)}{2} = \frac{100 + 40}{2} = 70 \text{ N/mm}^2. \text{ Ans.}$$

**Problem 3.10.** A small block is 4 cm long, 3 cm high and 0.5 cm thick. It is subjected to uniformly distributed tensile forces of resultants 1200 N and 500 N as shown in Fig. 3.7 (a) below. Compute the normal and shear stresses developed along the diagonal AB.

(AMIE, Summer 1987)

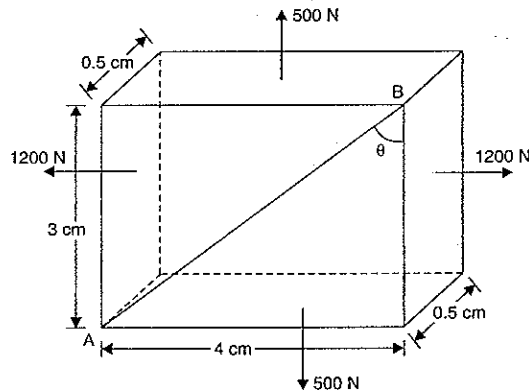

Fig. 3.7(a)

Sol. Given :

Length = 4 cm, height = 3 cm and width = 0.5 cm

Force along x-axis = 1200 N

Force along y-axis = 500 N

Area of cross-section normal to x-axis =  $3 \times 0.5 = 1.5 \text{ cm}^2$

Area of cross-section normal to y-axis =  $4 \times 0.5 = 2 \text{ cm}^2$

$$\therefore \text{Stress along x-axis} = \frac{\text{Force along x-axis}}{\text{Area normal to x-axis}}$$

$$= \frac{1200}{1.5} = 800 \text{ N/cm}^2$$

$$\therefore \sigma_1 = 800 \text{ N/cm}^2$$

$$\text{Stress along y-axis, } \sigma_2 = \frac{\text{Force along y-axis}}{\text{Area normal to y-axis}}$$

$$= \frac{500}{2} = 250 \text{ N/cm}^2$$

$$\text{Also } \tan \theta = \frac{4}{3} = 1.33$$

$$\therefore \theta = \tan^{-1} 1.33 = 53.06^\circ$$

Let  $\sigma_n$  = Normal stress on diagonal AB

$\sigma_t$  = Shear stress on diagonal AB

$$\text{Using equation (3.6), } \sigma_n = \frac{\sigma_1 + \sigma_2}{2} + \frac{\sigma_1 - \sigma_2}{2} \cos 2\theta$$

$$= \frac{800 + 250}{2} + \frac{800 - 250}{2} \cos (2 \times 53.06)$$

$$= 525 + 275 \times \cos 106.12^\circ = 525 + 275 \times (-0.2776)$$

$$= 525 - 76.35 = 448.65 \text{ N/cm}^2. \text{ Ans.}$$

$$\text{Now using equation (3.7), } \sigma_t = \frac{\sigma_1 - \sigma_2}{2} \sin 2\theta$$

$$= \frac{800 - 250}{2} \sin (2 \times 53.06^\circ)$$

$$= 275 \sin 106.12^\circ = 275 \times 0.96 = 264.18 \text{ N/cm}^2. \text{ Ans.}$$

### 3.4.3. A Member Subjected to a Simple Shear Stress.

Fig. 3.8 shows a rectangular bar ABCD of uniform cross-sectional area A and of unit thickness. The bar is subjected to a simple shear stress ( $q$ ) across the faces BC and AD. Let FC be the oblique section on which normal and tangential stresses are to be calculated.

Let  $\theta$  = Angle made by oblique section FC with normal cross-section BC,

$\tau$  = Shear stress across faces BC and AD.

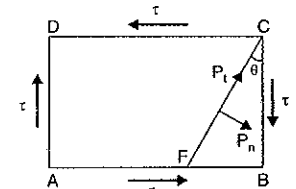

Fig. 3.8

It has already been proved (Refer Art. 2.9) that a shear stress is always accompanied by an equal shear stress at right angles to it. Hence the faces AB and CD will also be subjected to a shear stress  $q$  as shown in Fig. 3.8. Now these stresses will be converted into equivalent forces. Then these forces will be resolved along the inclined surface and normal to inclined surface. Consider the forces acting on the wedge FBC of Fig. 3.9.

Let

$$Q_1 = \text{Shear force on face } BC$$

$$= \text{Shear stress} \times \text{Area of face } BC$$

$$= \tau \times BC \times 1$$

$$(\because \text{Area of face } BC = BC \times 1)$$

$$= \tau \times BC$$

$$Q_2 = \text{Shear force on face } FB$$

$$= \tau \times \text{Area of } FB$$

$$= \tau \times FB \times 1 = \tau \cdot FB$$

$$P_n = \text{Total normal force on section } FC$$

$$P_t = \text{Total tangential force on section } FC.$$

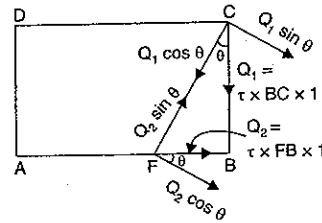

Fig. 3.9

The force  $Q_1$  is acting along face  $CB$  as shown in Fig. 3.9. This force is resolved into two components *i.e.*,  $Q_1 \cos \theta$  and  $Q_1 \sin \theta$  along the plane  $CF$  and normal to the plane  $CF$  respectively.

The force  $Q_2$  is acting along the face  $FB$ . This force is also resolved into two component *i.e.*,  $Q_2 \sin \theta$  and  $Q_2 \cos \theta$  along the plane  $FC$  and normal to the plane  $FC$  respectively.

$\therefore$  Total normal force on section  $FC$ ,

$$P_n = Q_1 \sin \theta + Q_2 \cos \theta$$

$$= \tau \times BC \times \sin \theta + \tau \times FB \times \cos \theta. \quad (\because Q_1 = \tau \times BC \text{ and } Q_2 = \tau \times FB)$$

And total tangential force on section  $FC$ .

$$P_t = Q_2 \sin \theta - Q_1 \cos \theta. \quad (-\text{ve sign is taken due to opposite direction})$$

$$= \tau \times FB \times \sin \theta - \tau \times BC \times \cos \theta \quad (\because Q_2 = \tau \cdot FB \text{ and } Q_1 = \tau \cdot BC)$$

Let

$$\sigma_n = \text{Normal stress on section } FC$$

$$\sigma_t = \text{Tangential stress on section } FC$$

Then

$$\sigma_n = \frac{\text{Total normal force on section } FC}{\text{Area of section } FC}$$

$$= \frac{P_n}{FC \times 1}$$

$$= \frac{\tau \cdot BC \cdot \sin \theta + \tau \cdot FB \cdot \cos \theta}{FC \times 1} \quad (\because \text{Area} = FC \times 1)$$

$$= \tau \cdot \frac{BC}{FC} \cdot \sin \theta + \tau \cdot \frac{FB}{FC} \cdot \cos \theta$$

$$= \tau \cdot \cos \theta \cdot \sin \theta + \tau \cdot \sin \theta \cdot \cos \theta$$

$$\left( \because \text{In triangle } FBC, \frac{BC}{FC} = \cos \theta, \frac{FB}{FC} = \sin \theta \right)$$

$$= 2\tau \cos \theta \cdot \sin \theta$$

$$= \tau \sin 2\theta \quad (\because 2 \sin \theta \cos \theta = \sin 2\theta) \quad \dots(3.10)$$

and

$$\sigma_t = \frac{\text{Total tangential force on section } FC}{\text{Area of section } FC}$$

$$= \frac{P_t}{FC \times 1}$$

$$= \frac{\tau \times FB \times \sin \theta - \tau \times BC \times \cos \theta}{FC \times 1}$$

$$= \tau \times \frac{FB}{FC} \times \sin \theta - \tau \times \frac{BC}{FC} \times \cos \theta$$

$$= \tau \times \sin \theta \times \sin \theta - \tau \times \cos \theta \times \cos \theta$$

$$= \tau \sin^2 \theta - \tau \cos^2 \theta = -\tau [\cos^2 \theta - \sin^2 \theta]$$

$$= -\tau \cos 2\theta \quad (\because \cos^2 \theta - \sin^2 \theta = \cos 2\theta) \quad \dots(3.11)$$

-ve sign shows that  $\sigma_t$  will be acting downwards on the plane  $CF$ .

**3.4.4. A Member Subjected to Direct Stresses in two Mutually Perpendicular Directions Accompanied by a Simple Shear Stress.** Fig. 3.10 (a) shows a rectangular bar  $ABCD$  of uniform cross-sectional area  $A$  and of unit thickness. This bar is subjected to :

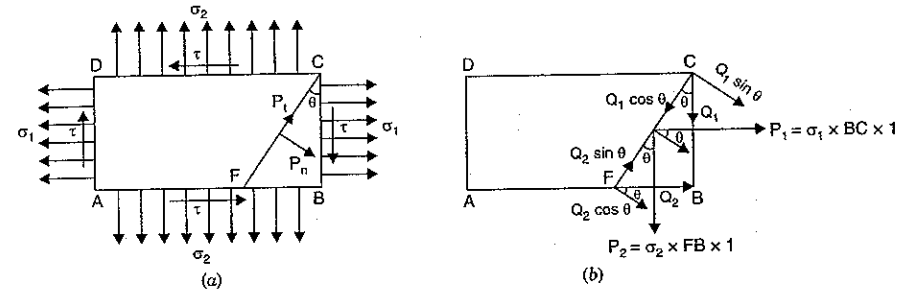

Fig. 3.10

- (i) tensile stress  $\sigma_1$  on the face  $BC$  and  $AD$
- (ii) tensile stress  $\sigma_2$  on the face  $AB$  and  $CD$
- (iii) a simple shear stress  $\tau$  on face  $BC$  and  $AD$ .

But with reference to Art. 2.9, a simple shear stress is always accompanied by an equal shear stress at right angles to it. Hence the faces  $AB$  and  $CD$  will also be subjected to a shear stress  $\tau$  as shown in Fig. 3.10 (a).

We want to calculate normal and tangential stresses on oblique section  $FC$ , which is inclined at an angle  $\theta$  with the normal cross-section  $BC$ . The given stresses are converted into equivalent forces.

The forces acting on the wedge  $FBC$  are :

$$P_1 = \text{Tensile force on face } BC \text{ due to tensile stress } \sigma_1$$

$$= \sigma_1 \times \text{Area of } BC$$

$$= \sigma_1 \times BC \times 1$$

$$= \sigma_1 \times BC \quad (\because \text{Area} = BC \times 1)$$

$$P_2 = \text{Tensile force on face } FB \text{ due to tensile stress } \sigma_2$$

$$= \sigma_2 \times \text{Area of } FB = \sigma_2 \times FB \times 1$$

$$= \sigma_2 \times FB$$

$$Q_1 = \text{Shear force on face } BC \text{ due to shear stress } \tau$$

$$= \tau \times \text{Area of } BC$$

$$= \tau \times BC \times 1 = \tau \times BC$$

$$Q_2 = \text{Shear force on face } FB \text{ due to shear stress } \tau$$

$$= \tau \times \text{Area of } FB$$

$$= \tau \times FB \times 1 = \tau \times FB.$$

Resolving the above four forces (*i.e.*,  $P_1, P_2, Q_1$  and  $Q_2$ ) normal to the oblique section  $FC$ , we get

Total normal force,

$$P_n = P_1 \cos \theta + P_2 \sin \theta + Q_1 \sin \theta + Q_2 \cos \theta$$

Substituting the values of  $P_1, P_2, Q_1$  and  $Q_2$ , we get

$$P_n = \sigma_1 \cdot BC \cdot \cos \theta + \sigma_2 \cdot FB \cdot \sin \theta + \tau \cdot BC \cdot \sin \theta + \tau \cdot FB \cdot \cos \theta$$

Similarly, the total tangential force ( $P_t$ ) is obtained by resolving  $P_1, P_2, Q_1$  and  $Q_2$  along the oblique section  $FC$ .

$\therefore$  Total tangential force,

$$\begin{aligned} P_t &= P_1 \sin \theta - P_2 \cos \theta - Q_1 \cos \theta + Q_2 \sin \theta \\ &= \sigma_1 \cdot BC \cdot \sin \theta - \sigma_2 \cdot FB \cdot \cos \theta - \tau \cdot BC \cdot \cos \theta + \tau \cdot FB \cdot \sin \theta \end{aligned}$$

(substitute the values of  $P_1, P_2, Q_1$  and  $Q_2$ )

Now, Let  $\sigma_n$  = Normal stress across the section  $FC$ , and

$\sigma_t$  = Tangential stress across the section  $FC$ .

Then normal stress across the section  $FC$ ,

$$\begin{aligned} \sigma_n &= \frac{\text{Total normal force across section } FC}{\text{Area of section } FC} = \frac{P_n}{FC \times 1} \\ &= \frac{\sigma_1 \cdot BC \cdot \cos \theta + \sigma_2 \cdot FB \cdot \sin \theta + \tau \cdot BC \cdot \sin \theta + \tau \cdot FB \cdot \cos \theta}{FC \times 1} \\ &= \sigma_1 \cdot \frac{BC}{FC} \cdot \cos \theta + \sigma_2 \cdot \frac{FB}{FC} \cdot \sin \theta + \tau \cdot \frac{BC}{FC} \cdot \sin \theta + \tau \cdot \frac{FB}{FC} \cdot \cos \theta \\ &= \sigma_1 \cdot \cos \theta \cdot \cos \theta + \sigma_2 \sin \theta \cdot \sin \theta + \tau \cdot \cos \theta \cdot \sin \theta + \tau \sin \theta \cdot \cos \theta \\ &\quad \left( \because \text{In triangle } FBC, \frac{BC}{FC} = \cos \theta \text{ and } \frac{FB}{FC} = \sin \theta \right) \\ &= \sigma_1 \cos^2 \theta + \sigma_2 \sin^2 \theta + 2\tau \cos \theta \sin \theta \\ &= \sigma_1 \left( \frac{1 + \cos 2\theta}{2} \right) + \sigma_2 \left( \frac{1 - \cos 2\theta}{2} \right) + \tau \sin 2\theta \\ &\quad \left( \because \cos^2 \theta = \frac{1 + \cos 2\theta}{2}, \sin^2 \theta = \frac{1 - \cos 2\theta}{2} \text{ and } 2 \cos \theta \sin \theta = \sin 2\theta \right) \\ &= \frac{\sigma_1 + \sigma_2}{2} + \frac{\sigma_1 - \sigma_2}{2} \cos 2\theta + \tau \sin 2\theta \end{aligned} \quad \dots(3.12)$$

and tangential stress (*i.e.*, shear stress) across the section  $FC$ ,

$$\begin{aligned} \sigma_t &= \frac{\text{Total tangential force across section } FC}{\text{Area of section } FC} = \frac{P_t}{FC \times 1} \\ &= \frac{\sigma_1 \cdot BC \cdot \sin \theta - \sigma_2 \cdot FB \cdot \cos \theta - \tau \cdot BC \cdot \cos \theta + \tau \cdot FB \cdot \sin \theta}{FC \times 1} \\ &= \sigma_1 \cdot \frac{BC}{FC} \cdot \sin \theta - \sigma_2 \cdot \frac{FB}{FC} \cdot \cos \theta - \tau \cdot \frac{BC}{FC} \cdot \cos \theta + \tau \cdot \frac{FB}{FC} \cdot \sin \theta \\ &= \sigma_1 \cdot \cos \theta \cdot \sin \theta - \sigma_2 \cdot \sin \theta \cdot \cos \theta - \tau \cdot \cos \theta \cdot \cos \theta + \tau \cdot \sin \theta \cdot \sin \theta \\ &\quad \left( \because \text{In triangle } FBC, \frac{BC}{FC} = \cos \theta \text{ and } \frac{FB}{FC} = \sin \theta \right) \\ &= (\sigma_1 - \sigma_2) \cdot \cos \theta \sin \theta - \tau \cos^2 \theta + \tau \sin^2 \theta \\ &= \left( \frac{\sigma_1 - \sigma_2}{2} \right) \cdot 2 \cos \theta \sin \theta - \tau (\cos^2 \theta - \sin^2 \theta) \end{aligned}$$

$$= \frac{\sigma_1 - \sigma_2}{2} \cdot \sin 2\theta - \tau \cos 2\theta \quad (\because \cos^2 \theta - \sin^2 \theta = \cos 2\theta) \quad \dots(3.13)$$

**Position of principal planes.** The planes on which shear stress (*i.e.*, tangential stress) is zero, are known as principal planes. And the stresses acting on principal planes are known as principal stresses.

The position of principal planes are obtained by equating the tangential stress [given by equation (3.13)] to zero.

$\therefore$  For principal planes,  $\sigma_t = 0$

$$\text{or} \quad \frac{\sigma_1 - \sigma_2}{2} \sin 2\theta - \tau \cos 2\theta = 0$$

$$\text{or} \quad \frac{\sigma_1 - \sigma_2}{2} \sin 2\theta = \tau \cos 2\theta$$

$$\text{or} \quad \frac{\sin 2\theta}{\cos 2\theta} = \frac{\tau}{\frac{\sigma_1 - \sigma_2}{2}} = \frac{2\tau}{\sigma_1 - \sigma_2}$$

$$\text{or} \quad \tan 2\theta = \frac{2\tau}{\sigma_1 - \sigma_2} \quad \dots(3.14)$$

But the tangent of any angle in a right angled triangle

$$= \frac{\text{Height of right angled triangle}}{\text{Base of right angled triangle}}$$

$$\therefore \frac{\text{Height of right angled triangle}}{\text{Base of right angled triangle}} = \frac{2\tau}{\sigma_1 - \sigma_2}$$

$\therefore$  Height of right angled triangle =  $2\tau$

Base of right angled triangle =  $(\sigma_1 - \sigma_2)$ .

Now diagonal of the right angled triangle

$$\begin{aligned} &= \pm \sqrt{(\sigma_1 - \sigma_2)^2 + (2\tau)^2} = \pm \sqrt{(\sigma_1 - \sigma_2)^2 + 4\tau^2} \\ &= \sqrt{(\sigma_1 - \sigma_2)^2 + 4\tau^2} \quad \text{and} \quad -\sqrt{(\sigma_1 - \sigma_2)^2 + 4\tau^2} \end{aligned}$$

$$\text{1st Case.} \quad \text{Diagonal} = \sqrt{(\sigma_1 - \sigma_2)^2 + 4\tau^2}$$

$$\text{Then} \quad \sin 2\theta = \frac{\text{Height}}{\text{Diagonal}} = \frac{2\tau}{\sqrt{(\sigma_1 - \sigma_2)^2 + 4\tau^2}}$$

$$\text{and} \quad \cos 2\theta = \frac{\text{Base}}{\text{Diagonal}} = \frac{(\sigma_1 - \sigma_2)}{\sqrt{(\sigma_1 - \sigma_2)^2 + 4\tau^2}}$$

The value of major principal stress is obtained by substituting the values of  $\sin 2\theta$  and  $\cos 2\theta$  in equation (3.12).

$\therefore$  Major principal stress

$$\begin{aligned} &= \frac{\sigma_1 + \sigma_2}{2} + \frac{\sigma_1 - \sigma_2}{2} \cos 2\theta + \tau \sin 2\theta \\ &= \frac{\sigma_1 + \sigma_2}{2} + \frac{\sigma_1 - \sigma_2}{2} \times \frac{(\sigma_1 - \sigma_2)}{\sqrt{(\sigma_1 - \sigma_2)^2 + 4\tau^2}} + \tau \times \frac{2\tau}{\sqrt{(\sigma_1 - \sigma_2)^2 + 4\tau^2}} \end{aligned}$$

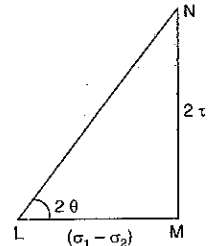

Fig. 3.11

$$\begin{aligned}
 &= \frac{\sigma_1 + \sigma_2}{2} + \frac{1}{2} \frac{(\sigma_1 - \sigma_2)^2}{\sqrt{(\sigma_1 - \sigma_2)^2 + 4\tau^2}} + \frac{2\tau^2}{\sqrt{(\sigma_1 - \sigma_2)^2 + 4\tau^2}} \\
 &= \frac{\sigma_1 + \sigma_2}{2} + \frac{(\sigma_1 - \sigma_2)^2 + 4\tau^2}{2\sqrt{(\sigma_1 - \sigma_2)^2 + 4\tau^2}} \\
 &= \frac{\sigma_1 + \sigma_2}{2} + \frac{1}{2} \sqrt{(\sigma_1 - \sigma_2)^2 + 4\tau^2} \\
 &= \frac{\sigma_1 + \sigma_2}{2} + \sqrt{\left(\frac{\sigma_1 - \sigma_2}{2}\right)^2 + \tau^2} \quad \dots(3.15)
 \end{aligned}$$

2nd Case. Diagonal =  $-\sqrt{(\sigma_1 - \sigma_2)^2 + 4\tau^2}$

Then 
$$\sin 2\theta = \frac{2\tau}{-\sqrt{(\sigma_1 - \sigma_2)^2 + 4\tau^2}}$$

and 
$$\cos 2\theta = \frac{(\sigma_1 - \sigma_2)}{-\sqrt{(\sigma_1 - \sigma_2)^2 + 4\tau^2}}$$

Substituting these values in equation (3.12), we get minor principal stress.

∴ Minor principal stress

$$\begin{aligned}
 &= \frac{\sigma_1 + \sigma_2}{2} + \frac{\sigma_1 - \sigma_2}{2} \cos 2\theta + \tau \sin 2\theta \\
 &= \frac{\sigma_1 + \sigma_2}{2} + \frac{\sigma_1 - \sigma_2}{2} \times \frac{\sigma_1 - \sigma_2}{-\sqrt{(\sigma_1 - \sigma_2)^2 + 4\tau^2}} + \tau \times \frac{2\tau}{-\sqrt{(\sigma_1 - \sigma_2)^2 + 4\tau^2}} \\
 &= \frac{\sigma_1 + \sigma_2}{2} - \frac{(\sigma_1 - \sigma_2)^2}{2\sqrt{(\sigma_1 - \sigma_2)^2 + 4\tau^2}} - \frac{2\tau^2}{\sqrt{(\sigma_1 - \sigma_2)^2 + 4\tau^2}} \\
 &= \frac{\sigma_1 + \sigma_2}{2} - \frac{(\sigma_1 - \sigma_2)^2 + 4\tau^2}{2\sqrt{(\sigma_1 - \sigma_2)^2 + 4\tau^2}} \\
 &= \frac{\sigma_1 + \sigma_2}{2} - \frac{1}{2} \sqrt{(\sigma_1 - \sigma_2)^2 + 4\tau^2} \\
 &= \frac{\sigma_1 + \sigma_2}{2} - \sqrt{\left(\frac{\sigma_1 - \sigma_2}{2}\right)^2 + \tau^2} \quad \dots(3.16)
 \end{aligned}$$

Equation (3.15) gives the maximum principal stress whereas equation (3.16) gives minimum principal stress. These two principal planes are at right angles.

The position of principal planes is obtained by finding two values of  $\theta$  from equation (3.14). Fig. 3.11(a) shows the principal planes in which  $\theta_1$  and  $\theta_2$  are the values from equation (3.14).

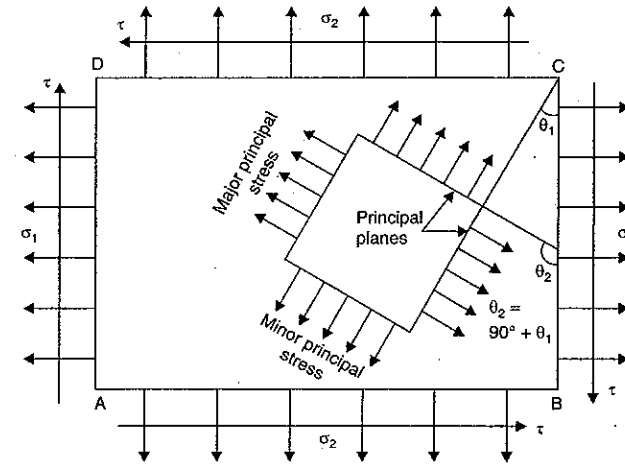

Fig. 3.11 (a)

**Maximum shear stress.** The shear stress is given by equation (3.13). The shear stress will be maximum or minimum when

$$\frac{d}{d\theta} (\sigma_x) = 0$$

or 
$$\frac{d}{d\theta} \left[ \frac{\sigma_1 - \sigma_2}{2} \sin 2\theta - \tau \cos 2\theta \right] = 0$$

or 
$$\frac{\sigma_1 - \sigma_2}{2} (\cos 2\theta) \times 2 - \tau (-\sin 2\theta) \times 2 = 0$$

or 
$$2\tau \sin 2\theta = -(\sigma_1 - \sigma_2) \cos 2\theta$$

or 
$$\frac{\sin 2\theta}{\cos 2\theta} = \frac{\sigma_2 - \sigma_1}{2\tau}$$

or 
$$\tan 2\theta = \frac{\sigma_2 - \sigma_1}{2\tau} \quad \dots(3.17)$$

Equation (3.17) gives condition for maximum or minimum shear stress.

If  $\tan 2\theta = \frac{\sigma_2 - \sigma_1}{2\tau}$

Then 
$$\sin 2\theta = \pm \frac{\sigma_2 - \sigma_1}{\sqrt{(\sigma_2 - \sigma_1)^2 + 4\tau^2}}$$

and 
$$\cos 2\theta = \pm \frac{2\tau}{\sqrt{(\sigma_2 - \sigma_1)^2 + 4\tau^2}}$$

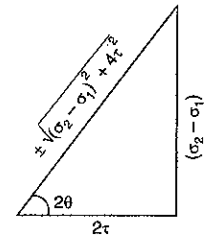

Fig. 3.12

Substituting the values of  $\sin 2\theta$  and  $\cos 2\theta$  in equation (3.13), the maximum and minimum shear stresses are obtained.

∴ Maximum shear stress is given by

$$\begin{aligned}
 (\sigma_t)_{\max} &= \frac{\sigma_1 - \sigma_2}{2} \sin 2\theta - \tau \cos 2\theta \\
 &= \pm \frac{\sigma_1 - \sigma_2}{2} \times \frac{(\sigma_2 - \sigma_1)}{\sqrt{(\sigma_2 - \sigma_1)^2 + 4\tau^2}} \pm \tau \times \frac{2\tau^2}{\sqrt{(\sigma_2 - \sigma_1)^2 + 4\tau^2}} \\
 &= \pm \frac{(\sigma_1 - \sigma_2)^2}{2\sqrt{(\sigma_2 - \sigma_1)^2 + 4\tau^2}} \pm \frac{2\tau^2}{\sqrt{(\sigma_2 - \sigma_1)^2 + 4\tau^2}} \\
 &= \pm \frac{(\sigma_2 - \sigma_1)^2 + 4\tau^2}{2\sqrt{(\sigma_2 - \sigma_1)^2 + 4\tau^2}} = \pm \frac{1}{2} \sqrt{(\sigma_2 - \sigma_1)^2 + 4\tau^2} \\
 \therefore (\sigma_t)_{\max} &= \frac{1}{2} \sqrt{(\sigma_2 - \sigma_1)^2 + 4\tau^2} \\
 &= \frac{1}{2} \sqrt{(\sigma_1 - \sigma_2)^2 + 4\tau^2} \quad \dots(3.18)
 \end{aligned}$$

The planes on which maximum shear stress is acting, are obtained after finding the two values of  $\theta$  from equation (3.17). These two values of  $\theta$  will differ by  $90^\circ$ .

The second method of finding the planes of maximum shear stress is to find first principal planes and principal stresses. Let  $\theta_1$  is the angle of principal plane with plane  $BC$  of Fig. 3.11 (a). Then the planes of maximum shear will be at  $\theta_1 + 45^\circ$  and  $\theta_1 + 135^\circ$  with the plane  $BC$  as shown in Fig. 3.12 (a).

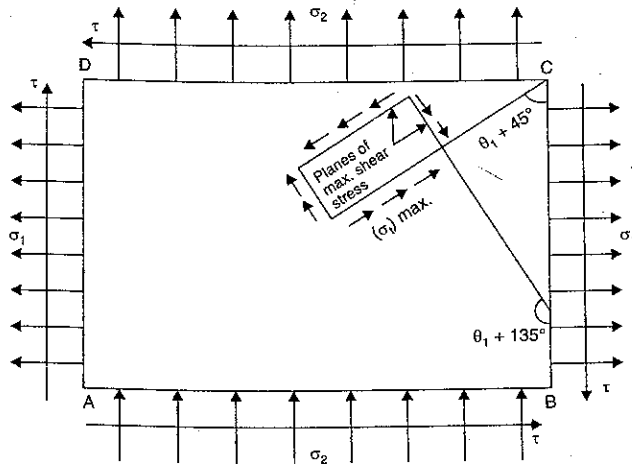

Fig. 3.12 (a)

Note. The above relations hold good when one or both the stresses are compressive.

**Problem 3.11.** At a point within a body subjected to two mutually perpendicular directions, the stresses are  $80 \text{ N/mm}^2$  tensile and  $40 \text{ N/mm}^2$  tensile. Each of the above stresses is accompanied by a shear stress of  $60 \text{ N/mm}^2$ . Determine the normal stress, shear stress and resultant stress on an oblique plane inclined at an angle of  $45^\circ$  with the axis of minor tensile stress.

Sol. Given :

Major tensile stress,  $\sigma_1 = 80 \text{ N/mm}^2$

Minor tensile stress,  $\sigma_2 = 40 \text{ N/mm}^2$

Shear stress,  $\tau = 60 \text{ N/mm}^2$

Angle of oblique plane, with the axis of minor tensile stress,

$$\theta = 45^\circ.$$

(i) Normal stress ( $\sigma_n$ )

Using equation (3.12),

$$\begin{aligned}
 \sigma_n &= \frac{\sigma_1 + \sigma_2}{2} + \frac{\sigma_1 - \sigma_2}{2} \cos 2\theta + \tau \sin 2\theta \\
 &= \frac{80 + 40}{2} + \frac{80 - 40}{2} \cos (2 \times 45^\circ) + 60 \sin (2 \times 45^\circ) \\
 &= 60 + 20 \cos 90^\circ + 60 \sin 90^\circ \\
 &= 60 + 20 \times 0 + 60 \times 1 \\
 &= 60 + 0 + 60 = 120 \text{ N/mm}^2. \quad \text{Ans.} \quad (\because \cos 90^\circ = 0)
 \end{aligned}$$

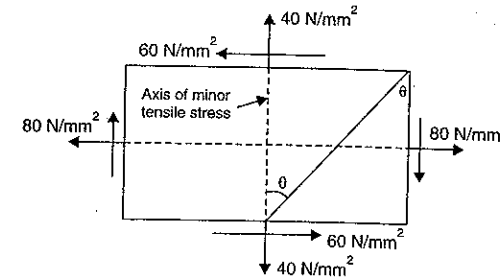

Fig. 3.13

(ii) Shear (or tangential) stress ( $\sigma_t$ )

Using equation (3.13),

$$\begin{aligned}
 \sigma_t &= \frac{\sigma_1 - \sigma_2}{2} \sin 2\theta - \tau \cos 2\theta \\
 &= \frac{80 - 40}{2} \sin (2 \times 45^\circ) - 60 \times \cos (2 \times 45^\circ) \\
 &= 20 \times \sin 90^\circ - 60 \cos 90^\circ \\
 &= 20 \times 1 - 60 \times 0 \\
 &= 20 \text{ N/mm}^2. \quad \text{Ans.}
 \end{aligned}$$

(iii) Resultant stress ( $\sigma_R$ )

Using equation,  $\sigma_R = \sqrt{\sigma_n^2 + \sigma_t^2}$

$$= \sqrt{120^2 + 20^2} = \sqrt{14400 + 400}$$

$$= \sqrt{14800} = 121.655 \text{ N/mm}^2. \text{ Ans.}$$

**Problem 3.12.** A rectangular block of material is subjected to a tensile stress of 110 N/mm<sup>2</sup> on one plane and a tensile stress of 47 N/mm<sup>2</sup> on the plane at right angles to the former. Each of the above stresses is accompanied by a shear stress of 63 N/mm<sup>2</sup> and that associated with the former tensile stress tends to rotate the block anticlockwise. Find :

- (i) the direction and magnitude of each of the principal stress and  
 (ii) magnitude of the greatest shear stress. (AMIE, Summer 1983)

**Sol. Given :**

Major tensile stress,  $\sigma_1 = 110 \text{ N/mm}^2$

Minor tensile stress,  $\sigma_2 = 47 \text{ N/mm}^2$

Shear stress,  $\tau = 63 \text{ N/mm}^2$

(i) Major principal stress is given by equation (3.15).

$$\therefore \text{Major principal stress} = \frac{\sigma_1 + \sigma_2}{2} + \sqrt{\left(\frac{\sigma_1 - \sigma_2}{2}\right)^2 + \tau^2}$$

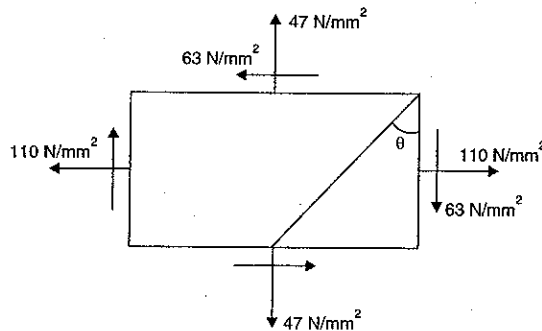

Fig. 3.14

$$= \frac{110 + 47}{2} + \sqrt{\left(\frac{110 - 47}{2}\right)^2 + 63^2}$$

$$= \frac{157}{2} + \sqrt{\left(\frac{63}{2}\right)^2 + (63)^2}$$

$$= 78.5 + \sqrt{31.5^2 + 63^2} = 78.5 + \sqrt{992.25 + 3969}$$

$$= 78.5 + 70.436 = 148.936 \text{ N/mm}^2. \text{ Ans.}$$

Minor principal stress is given by equation (3.16).

$$\therefore \text{Minor principal stress,} = \frac{\sigma_1 + \sigma_2}{2} - \sqrt{\left(\frac{\sigma_1 - \sigma_2}{2}\right)^2 + \tau^2}$$

$$= \frac{110 + 47}{2} - \sqrt{\left(\frac{110 - 47}{2}\right)^2 + 63^2} = 78.5 - 70.436$$

$$= 8.064 \text{ N/mm}^2. \text{ Ans.}$$

The directions of principal stresses are given by equation (3.14).

$\therefore$  Using equation (3.14),

$$\tan 2\theta = \frac{2\tau}{\sigma_1 - \sigma_2} = \frac{2 \times 63}{110 - 47}$$

$$= \frac{2 \times 63}{63} = 2.0$$

$\therefore 2\theta = \tan^{-1} 2.0 = 63^\circ 26'$  or  $243^\circ 26'$

$\therefore \theta = 31^\circ 43'$  or  $121^\circ 43'$ . Ans.

(ii) Magnitude of the greatest shear stress

Greatest shear stress is given by equation (3.18).

Using equation (3.18),

$$(\sigma_r)_{\max} = \frac{1}{2} \sqrt{(\sigma_1 - \sigma_2)^2 + 4\tau^2}$$

$$= \frac{1}{2} \sqrt{(110 - 47)^2 + 4 \times 63^2}$$

$$= \frac{1}{2} \sqrt{63^2 + 4 \times 63^2} = \frac{1}{2} \times 63 \times \sqrt{5}$$

$$= 70.436 \text{ N/mm}^2. \text{ Ans.}$$

**Problem 3.13.** Direct stresses of 120 N/mm<sup>2</sup> tensile and 90 N/mm<sup>2</sup> compression exist on two perpendicular planes at a certain point in a body. They are also accompanied by shear stress on the planes. The greatest principal stress at the point due to these is 150 N/mm<sup>2</sup>.

- (a) What must be the magnitude of the shearing stresses on the two planes ?  
 (b) What will be the maximum shearing stress at the point ?

**Sol. Given :**

Major tensile stress,  $\sigma_1 = 120 \text{ N/mm}^2$

Minor compressive stress,  $\sigma_2 = -90 \text{ N/mm}^2$  (Minus sign due to compression)

Greatest principal stress = 150 N/mm<sup>2</sup>

(a) Let  $\tau$  = Shear stress on the two planes.

Using equation (3.15) for greatest principal stress, we get

$$\text{Greatest principal stress} = \frac{\sigma_1 + \sigma_2}{2} + \sqrt{\left(\frac{\sigma_1 - \sigma_2}{2}\right)^2 + \tau^2}$$

$$150 = \frac{120 + (-90)}{2} + \sqrt{\left(\frac{120 - (-90)}{2}\right)^2 + \tau^2}$$

$$= \frac{120 - 90}{2} + \sqrt{\left(\frac{120 + 90}{2}\right)^2 + \tau^2}$$

or

$$= 15 + \sqrt{105^2 + \tau^2}$$

or

$$150 - 15 = \sqrt{105^2 + \tau^2}$$

or

$$135 = \sqrt{105^2 + \tau^2}$$

Squaring both sides, we get

$$135^2 = 105^2 + \tau^2$$

or

$$\tau^2 = 135^2 - 105^2 = 18225 - 11025 = 7200$$

$$\therefore \tau = \sqrt{7200} = 84.853 \text{ N/mm}^2. \text{ Ans.}$$

(b) Maximum shear stress at the point

Using equation (3.18) for maximum shear stress,

$$\begin{aligned} (\sigma_s)_{\max} &= \frac{1}{2} \sqrt{(\sigma_1 - \sigma_2)^2 + 4\tau^2} \\ &= \frac{1}{2} \sqrt{[120 - (-90)]^2 + 4 \times 7200} \quad (\because \tau^2 = 7200) \\ &= \frac{1}{2} \sqrt{210^2 + 28800} = \frac{1}{2} \sqrt{44100 + 28800} = \frac{1}{2} \times 270 \\ &= 135 \text{ N/mm}^2. \text{ Ans.} \end{aligned}$$

**Problem 3.14.** At a certain point in a strained material, the stresses on two planes, at right angles to each other are  $20 \text{ N/mm}^2$  and  $10 \text{ N/mm}^2$  both tensile. They are accompanied by a shear stress of a magnitude of  $10 \text{ N/mm}^2$ . Find graphically or otherwise, the location of principal planes and evaluate the principal stresses. (AMIE, Summer 1984)

Sol. Given :

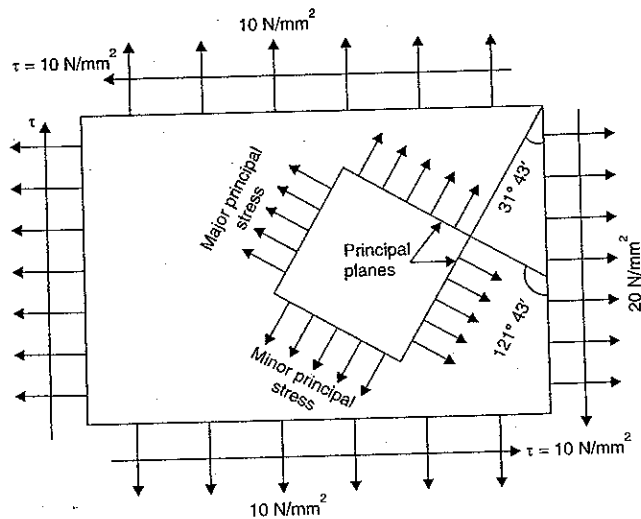

Fig. 3.14 (a)

Major tensile stress,  $\sigma_1 = 20 \text{ N/mm}^2$

Minor tensile stress,  $\sigma_2 = 10 \text{ N/mm}^2$

Shear stress,  $\tau = 10 \text{ N/mm}^2$

Location of principal planes

The location of principal planes is given by equation (3.14).

Using equation (3.14),

$$\tan 2\theta = \frac{2\tau}{\sigma_1 - \sigma_2} = \frac{2 \times 10}{20 - 10} = \frac{2 \times 10}{10} = 2.0$$

$$\therefore 2\theta = \tan^{-1} 2.0 = 63^\circ 26' \text{ or } 243^\circ 26'$$

$$\theta = 31^\circ 43' \text{ or } 121^\circ 43'. \text{ Ans.}$$

or

Magnitude of principal stresses

The major principal stress is given by equation (3.15)

$\therefore$  Major principal stress

$$\begin{aligned} &= \frac{\sigma_1 + \sigma_2}{2} + \sqrt{\left(\frac{\sigma_1 - \sigma_2}{2}\right)^2 + \tau^2} = \frac{20 + 10}{2} + \sqrt{\left(\frac{20 - 10}{2}\right)^2 + 10^2} \\ &= 15 + \sqrt{5^2 + 100} = 15 + \sqrt{25 + 100} = 15 + \sqrt{125} = 15 + 11.18 \\ &= 26.18 \text{ N/mm}^2. \text{ Ans.} \end{aligned}$$

The minor principal stress is given by equation (3.16).

$\therefore$  Minor principal stress

$$\begin{aligned} &= \frac{\sigma_1 + \sigma_2}{2} - \sqrt{\left(\frac{\sigma_1 - \sigma_2}{2}\right)^2 + \tau^2} \\ &= \frac{20 + 10}{2} - \sqrt{\left(\frac{20 - 10}{2}\right)^2 + 10^2} \\ &= 15 - 11.18 = 3.82 \text{ N/mm}^2. \text{ Ans.} \end{aligned}$$

**Problem 3.15.** A point in a strained material is subjected to the stresses as shown in Fig. 3.15.

Locate the principal planes, and evaluate the principal stresses.

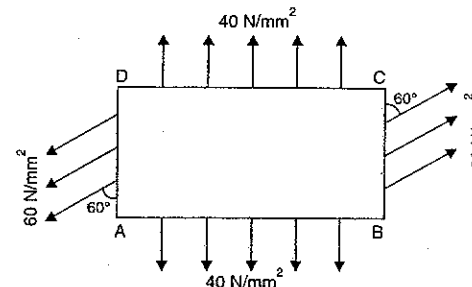

Fig. 3.15



**Sol. Given :**

The stress on the face  $BC$  or  $AD$  is not normal. It is inclined at an angle of  $60^\circ$  with face  $BC$  or  $AD$ . This stress can be resolved into two components *i.e.*, normal to the face  $BC$  (or  $AD$ ) and along the face  $BC$  (or  $AD$ ).

$$\therefore \text{Stress normal to the face } BC \text{ or } AD \\ = 60 \times \sin 60^\circ = 60 \times 0.866 = 51.96 \text{ N/mm}^2$$

$$\text{Stress along the face } BC \text{ or } AD \\ = 60 \times \cos 60^\circ = 60 \times 0.5 = 30 \text{ N/mm}^2$$

The stress along the face  $BC$  or  $AD$  is known as shear stress. Hence  $\tau = 30 \text{ N/mm}^2$ . Due to complementary shear stress the face  $AB$  and  $CD$  will also be subjected to shear stress of  $30 \text{ N/mm}^2$ . Now the stresses acting on the material are shown in Fig. 3.16.

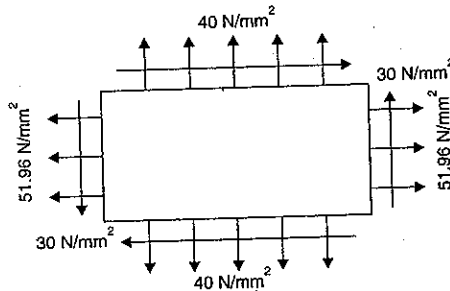

Fig. 3.16

$$\begin{aligned} \text{Major tensile stress, } \sigma_1 &= 51.96 \text{ N/mm}^2 \\ \text{Minor tensile stress, } \sigma_2 &= 40 \text{ N/mm}^2 \\ \text{Shear stress, } \tau &= 30 \text{ N/mm}^2 \end{aligned}$$

*Location of principal planes*

Let  $\theta$  = Angle, which one of the principal planes make with the stress of  $40 \text{ N/mm}^2$ .  
The location of the principal planes is given by the equation (3.14).  
Using equation (3.14), we get

$$\tan 2\theta = \frac{2\tau}{\sigma_1 - \sigma_2} = \frac{2 \times 30}{51.96 - 40} = 4.999$$

$$2\theta = \tan^{-1} 4.999 = 78^\circ 42' \text{ or } 258^\circ 42'$$

$$\theta = 39^\circ 21' \text{ or } 129^\circ 21'. \text{ Ans.}$$

or

*Principal stress*

The major principal stress is given by equation (3.15).

$\therefore$  Major principal stress

$$\begin{aligned} &= \frac{\sigma_1 + \sigma_2}{2} + \sqrt{\left(\frac{\sigma_1 - \sigma_2}{2}\right)^2 + \tau^2} \\ &= \frac{51.96 + 40}{2} + \sqrt{\left(\frac{51.96 - 40}{2}\right)^2 + 30^2} \end{aligned}$$

$$= 45.98 + 30.6$$

$$= 76.58 \text{ N/mm}^2. \text{ Ans.}$$

The minor principal stress is given by equation (3.16).

$\therefore$  Minor principal stress

$$\begin{aligned} &= \frac{\sigma_1 + \sigma_2}{2} - \sqrt{\left(\frac{\sigma_1 - \sigma_2}{2}\right)^2 + \tau^2} \\ &= \frac{51.96 + 40}{2} - \sqrt{\left(\frac{51.96 - 40}{2}\right)^2 + 30^2} \\ &= 45.98 - 30.6 \\ &= 15.38 \text{ N/mm}^2. \text{ Ans.} \end{aligned}$$

**Problem 3.16.** The normal stress in two mutually perpendicular directions are  $600 \text{ N/mm}^2$  and  $300 \text{ N/mm}^2$  both tensile. The complimentary shear stresses in these directions are of intensity  $450 \text{ N/mm}^2$ . Find the normal and tangential stresses on the two planes which are equally inclined to the planes carrying the normal stresses mentioned above.

**Sol. Given :**

$$\text{Major tensile stress, } \sigma_1 = 600 \text{ N/mm}^2$$

$$\text{Minor tensile stress, } \sigma_2 = 300 \text{ N/mm}^2$$

$$\text{Shear stress, } \tau = 450 \text{ N/mm}^2$$

The normal and tangential stresses are to be calculated on the two planes which are equally inclined to the planes of major tensile stress and of minor tensile stress. This means  $\theta = 45^\circ$  and  $135^\circ$ .

$\therefore$  Angle  $\theta = 45^\circ$  and  $135^\circ$ .

(i) Normal stress ( $\sigma_n$ ) is given by equation (3.12).

$$\therefore \sigma_n = \frac{\sigma_1 + \sigma_2}{2} + \frac{\sigma_1 - \sigma_2}{2} \cos 2\theta + \tau \sin 2\theta$$

(a) When  $\theta = 45^\circ$ , the normal stresses ( $\sigma_n$ ) becomes as

$$\begin{aligned} \sigma_n &= \frac{600 + 300}{2} + \frac{600 - 300}{2} \cos (2 \times 45^\circ) + 450 \sin (2 \times 45^\circ) \\ &= 450 + 150 \cos 90^\circ + 450 \sin 90^\circ \\ &= 450 + 150 \times 0 + 450 \times 1 \quad (\because \cos 90^\circ = 0 \text{ and } \sin 90^\circ = 1) \\ &= 900 \text{ N/mm}^2. \text{ Ans.} \end{aligned}$$

(b) When  $\theta = 135^\circ$ , the normal stress ( $\sigma_n$ ) becomes as

$$\begin{aligned} \sigma_n &= \frac{600 + 300}{2} + \frac{600 - 300}{2} \cos (2 \times 135^\circ) + 450 \sin (2 \times 135^\circ) \\ &= 450 + 150 \cos (270^\circ) + 450 \sin 270^\circ \\ &= 450 + 150 \times 0 + 450 \times (-1) \quad (\because \cos 270^\circ = 0 \text{ and } \sin 270^\circ = -1) \\ &= 450 - 450 = 0. \text{ Ans.} \end{aligned}$$

(ii) Tangential stress ( $\sigma_t$ ) is given by equation (3.13)

$$\therefore \sigma_t = \frac{\sigma_1 - \sigma_2}{2} \sin 2\theta - \tau \cos 2\theta$$

(a) When  $\theta = 45^\circ$ , the tangential stress ( $\sigma_t$ ) becomes as

$$\begin{aligned}\sigma_t &= \frac{600 - 300}{2} \sin 90^\circ - 450 \cos 90^\circ \\ &= 150 \times 1 - 450 \times 0 = \mathbf{150 \text{ N/mm}^2}. \text{ Ans.}\end{aligned}$$

(b) When  $\theta = 135^\circ$ , the tangential stress ( $\sigma_t$ ) becomes as

$$\begin{aligned}\sigma_t &= \frac{600 - 300}{2} \sin 270^\circ - 450 \cos 270^\circ \\ &= 150 \times (-1) - 450 \times 0 = \mathbf{-150 \text{ N/mm}^2}. \text{ Ans.}\end{aligned}$$

**Problem 3.17.** The intensity of resultant stress on a plane AB [Fig. 3.16 (a)] at a point in a material under stress is  $800 \text{ N/cm}^2$  and it is inclined at  $30^\circ$  to the normal to that plane. The normal component of stress on another plane BC at right angles to plane AB is  $600 \text{ N/cm}^2$ .

Determine the following :

- the resultant stress on the plane BC,
- the principal stresses and their directions,
- the maximum shear stresses and their planes.

(AMIE, Summer 1989)

**Sol. Given :**

Resultant stress on plane AB =  $800 \text{ N/cm}^2$

Angle of inclination of the above stress =  $30^\circ$

Normal stress on plane BC =  $600 \text{ N/cm}^2$

The resultant stress  $800 \text{ N/cm}^2$  on plane AB is resolved into normal stress and tangential stress.

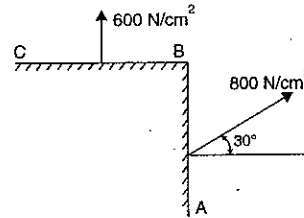

Fig. 3.16 (a)

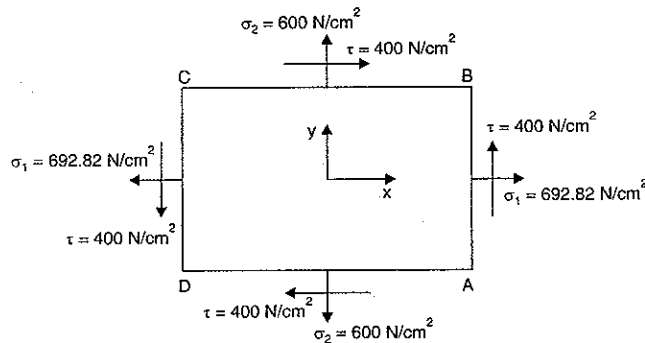

Fig. 3.16 (b)

The normal stress on plane AB

$$= 800 \times \cos 30^\circ = 692.82 \text{ N/cm}^2.$$

The tangential stress on plane AB

$$= 800 \times \sin 30^\circ = 400 \text{ N/cm}^2.$$

The shear stress on plane AB is, i.e.,  $\tau_{AB} = 400 \text{ N/cm}^2$ , then to maintain the equilibrium on the wedge ABC, another shear stress of the same magnitude, i.e.,  $\tau_{BC} = 400 \text{ N/cm}^2$  must act on the plane BC. The free body diagram of the element ABCD is shown in Fig. 3.16 (a), showing normal and shear stresses acting on different faces.

(i) Resultant stress on plane BC

On plane BC, from Fig. 3.16 (a),

$$\sigma_2 = 600 \text{ N/cm}^2$$

Shear stress,  $\tau = 400 \text{ N/cm}^2$

∴ Resultant stress on plane BC

$$\begin{aligned}&= \sqrt{\sigma_2^2 + \tau^2} \\ &= \sqrt{600^2 + 400^2} = \mathbf{721 \text{ N/cm}^2}. \text{ Ans.}\end{aligned}$$

The resultant will be inclined at an angle  $\theta$  with the horizontal given by,

$$\tan \theta = \frac{\sigma_2}{\tau} = \frac{600}{400} = 1.5$$

∴  $\theta = \tan^{-1} 1.5 = \mathbf{56.3^\circ}. \text{ Ans.}$

(ii) Principal stresses and their directions

The major principal stress is given by equation (3.15).

∴ Major principal stress

$$\begin{aligned}&= \frac{\sigma_1 + \sigma_2}{2} + \sqrt{\left(\frac{\sigma_1 - \sigma_2}{2}\right)^2 + \tau^2} \\ &= \frac{692.82 + 600}{2} + \sqrt{\left(\frac{692.82 - 600}{2}\right)^2 + 400^2} \\ &= 646.41 + 402.68 \\ &= \mathbf{1049.09 \text{ N/cm}^2} \text{ (Tensile). Ans.}\end{aligned}$$

The minor principal stress is given by equation (3.16)

∴ Minor principal stress

$$\begin{aligned}&= \frac{\sigma_1 + \sigma_2}{2} - \sqrt{\left(\frac{\sigma_1 - \sigma_2}{2}\right)^2 + \tau^2} \\ &= \frac{692.82 + 600}{2} - \sqrt{\left(\frac{692.82 - 600}{2}\right)^2 + 400^2} \\ &= 646.41 - 402.68 \\ &= \mathbf{243.73 \text{ N/cm}^2} \text{ (Tensile). Ans.}\end{aligned}$$

The directions of principal stresses are given by equation (3.14), as

$$\tan 2\theta = \frac{2\tau}{(\sigma_1 - \sigma_2)} = \frac{2 \times 400}{(692.82 - 600)} = \frac{800}{92.82} = 8.618$$

∴  $2\theta = \tan^{-1} 8.618 = 83.38^\circ$  or  $263.38^\circ$

∴  $\theta = \mathbf{41.69^\circ}$  or  $\mathbf{131.99^\circ}. \text{ Ans.}$

(iii) The maximum shear stress and their planes.

The maximum shear stress is given by equation (3.18).

$$\begin{aligned} \therefore (\sigma_t)_{\max} &= \frac{1}{2} \sqrt{(\sigma_1 - \sigma_2)^2 + 4\tau^2} = \sqrt{\left(\frac{\sigma_1 - \sigma_2}{2}\right)^2 + \tau^2} \\ &= \sqrt{\left(\frac{692.82 - 600}{2}\right)^2 + 400^2} \\ &= 402.68 \text{ N/cm}^2. \text{ Ans.} \end{aligned}$$

**Problem 3.18.** At a certain point in a material under stress the intensity of the resultant stress on a vertical plane is  $1000 \text{ N/cm}^2$  inclined at  $30^\circ$  to the normal to that plane and the stress on a horizontal plane has a normal tensile component of intensity  $600 \text{ N/cm}^2$  as shown in Fig. 3.16 (c). Find the magnitude and direction of the resultant stress on the horizontal plane and the principal stresses. (AMIE, Winter 1990)

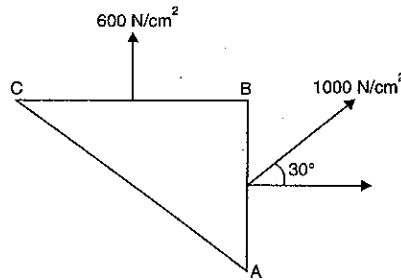

Fig. 3.16 (c)

**Sol. Given :**

Resultant stress on vertical plane  $AB = 1000 \text{ N/cm}^2$

Inclination of the above stress =  $30^\circ$

Normal stress on horizontal plane  $BC = 600 \text{ N/cm}^2$

The resultant stress on plane  $AB$  is resolved into normal and tangential component.

The normal component

$$= 1000 \times \cos 30^\circ = 866 \text{ N/cm}^2$$

Tangential component

$$= 1000 \times \sin 30^\circ = 500 \text{ N/cm}^2.$$

Hence a shear stress of magnitude  $500 \text{ N/cm}^2$  is acting on plane  $AB$ . To maintain the wedge in equilibrium, another shear stress of the same magnitude but opposite in direction must act on the plane  $BC$ . The free-body diagram of the element  $ABCD$  is shown in Fig. 3.16 (d), showing normal and shear stresses acting on different faces in which :

$$\sigma_1 = 866 \text{ N/cm}^2,$$

$$\sigma_2 = 600 \text{ N/cm}^2$$

$$\tau = 500 \text{ N/cm}^2$$

and

(i) Magnitude and direction of resultant stress on horizontal plane  $BC$ .

Normal stress on plane  $BC$ ,  $\sigma_2 = 600 \text{ N/cm}^2$

Tangential stress on plane  $BC$ ,  $\tau = 500 \text{ N/cm}^2$

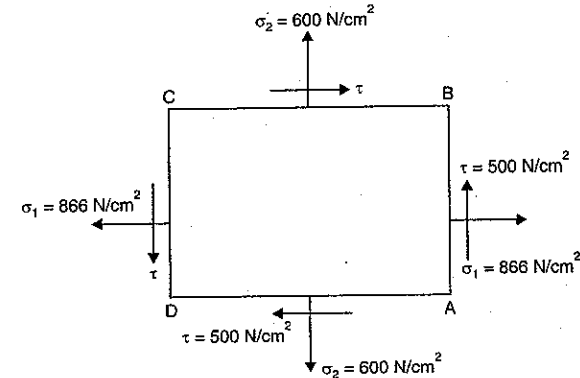

Fig. 3.16 (d)

$$\begin{aligned} \therefore \text{Resultant stress} &= \sqrt{\sigma_2^2 + \tau^2} \\ &= \sqrt{600^2 + 500^2} = 781.02 \text{ N/cm}^2. \text{ Ans.} \end{aligned}$$

The direction of the resultant stress with the horizontal plane  $BC$  is given by,

$$\tan \theta = \frac{\sigma_2}{\tau} = \frac{600}{500} = 1.2$$

$$\theta = \tan^{-1} 1.2 = 50.19^\circ. \text{ Ans.}$$

(ii) Principal stresses

The major and minor principal stresses are given by equations (3.15) and (3.16).

$$\begin{aligned} \therefore \text{Principal stresses} &= \frac{\sigma_1 + \sigma_2}{2} \pm \sqrt{\left(\frac{\sigma_1 - \sigma_2}{2}\right)^2 + \tau^2} \\ &= \frac{866 + 600}{2} \pm \sqrt{\left(\frac{866 - 600}{2}\right)^2 + 500^2} \\ &= 733 \pm 517.38 \\ &= (733 + 517.38) \text{ and } (733 - 517.38) \\ &= 1250.38 \text{ and } 215.62 \text{ N/cm}^2. \end{aligned}$$

$\therefore$  Major principal stress =  $1250.38 \text{ N/cm}^2$ . Ans.

$\therefore$  Minor principal stress =  $215.62 \text{ N/cm}^2$ . Ans.

**Problem 3.19.** At a point in a strained material, on plane  $BC$  there are normal and shear stresses of  $560 \text{ N/mm}^2$  and  $140 \text{ N/mm}^2$  respectively. On plane  $AC$ , perpendicular to plane  $BC$ , there are normal and shear stresses of  $280 \text{ N/mm}^2$  and  $140 \text{ N/mm}^2$  respectively as shown in Fig. 3.16 (e). Determine the following :

(i) principal stresses and location of the planes on which they act,

(ii) maximum shear stress and the plane on which it acts. (AMIE, Summer 1990)

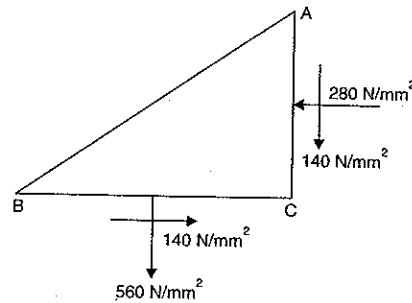

Fig. 3.16 (e)

Sol. Given :

On plane AC,  $\sigma_1 = -280 \text{ N/mm}^2$  (-ve sign due to compressive stress)

$$\tau = 140 \text{ N/mm}^2$$

On plane BC,  $\sigma_2 = 560 \text{ N/mm}^2$

$$\tau = 140 \text{ N/mm}^2$$

(i) Principal stresses and location of the planes on which they act.

Principal stress are given by equations (3.15) and (3.16)

$$\begin{aligned} \therefore \text{Principal stresses} &= \frac{\sigma_1 + \sigma_2}{2} \pm \sqrt{\left(\frac{\sigma_1 - \sigma_2}{2}\right)^2 + \tau^2} \\ &= \frac{-280 + 560}{2} \pm \sqrt{\left(\frac{-280 - 560}{2}\right)^2 + 140^2} \\ &= 140 \pm 442.7 \\ &= 582.7 \text{ and } (140 - 442.7) \text{ N/mm}^2 \\ &= 582.7 \text{ and } -302.7 \text{ N/mm}^2 \end{aligned}$$

$\therefore$  Major principal stress = **582.7 N/mm<sup>2</sup> (Tensile). Ans.**

$\therefore$  Minor principal stress = **-302.7 N/mm<sup>2</sup>. Ans.**

The planes on which principal stresses act, are given by equation (3.14) as

$$\tan 2\theta = \frac{2\tau}{\sigma_1 - \sigma_2} = \frac{2 \times 140}{-280 - 560} = \frac{280}{-840} = -0.33$$

$$\therefore 2\theta = \tan^{-1} -0.33 = -18.26^\circ$$

-ve sign shows that  $2\theta$  is lying in 2nd and 4th quadrant

$$\therefore 2\theta = (180 - 18.26^\circ) \text{ or } (360 - 18.26^\circ)$$

$$= 161.34^\circ \text{ or } 341.34^\circ$$

$\therefore \theta = 80.67^\circ \text{ and } 170.67^\circ. \text{ Ans.}$

(ii) Maximum shear stress and the plane on which it acts.

Maximum shear stress is given by equation (3.18).

$$\begin{aligned} \therefore (\sigma_t)_{\max} &= \sqrt{\left(\frac{\sigma_1 - \sigma_2}{2}\right)^2 + \tau^2} \\ &= \sqrt{\left(\frac{-280 - 560}{2}\right)^2 + 140^2} \\ &= \sqrt{420^2 + 140^2} = 442.7 \text{ N/mm}^2. \text{ Ans.} \end{aligned}$$

The plane on which maximum shear stress acts is given by equation (3.17) as

$$\begin{aligned} \tan 2\theta &= \frac{\sigma_2 - \sigma_1}{2\tau} \\ &= \frac{560 - (-280)}{2 \times 140} = \frac{840}{280} = 3.0 \end{aligned}$$

$$\therefore 2\theta = \tan^{-1} 3.0 = 71.56^\circ \text{ or } 251.56^\circ$$

$$\therefore \theta = 35.78^\circ \text{ or } 125.78^\circ. \text{ Ans.}$$

**Problem 3.20.** On a mild steel plate, a circle of diameter 50 mm is drawn before the plate is stressed as shown in Fig. 3.17. Find the lengths of the major and minor axes of an ellipse formed as a result of the deformation of the circle marked.

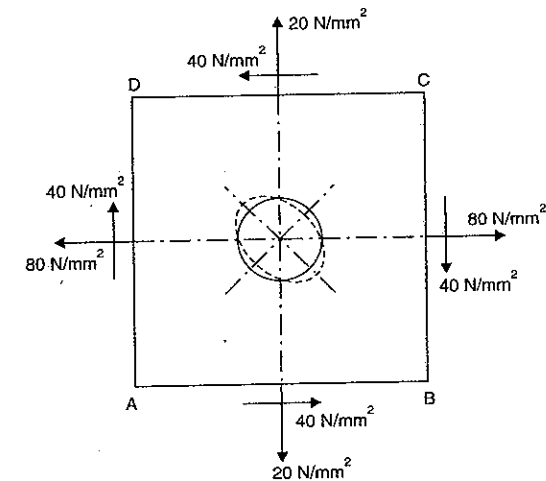

Fig. 3.17

Take  $E = 2 \times 10^5 \text{ N/mm}^2$  and  $\frac{1}{m} = \frac{1}{4}$ .

Sol. Given :

Major tensile stress,  $\sigma_1 = 80 \text{ N/mm}^2$

Minor tensile stress,  $\sigma_2 = 20 \text{ N/mm}^2$

Shear stress,  $\tau = 40 \text{ N/mm}^2$

Value of  $E = 2 \times 10^5 \text{ N/mm}^2$

Major principal stress is given by equation (3.15).

$\therefore$  Major principal stress

$$= \frac{\sigma_1 + \sigma_2}{2} + \sqrt{\left(\frac{\sigma_1 - \sigma_2}{2}\right)^2 + \tau^2}$$

$$= \frac{80 + 20}{2} + \sqrt{\left(\frac{80 - 20}{2}\right)^2 + 40^2}$$

$$= 50 + \sqrt{30^2 + 40^2} = 50 + 50 = 100 \text{ N/mm}^2 \text{ (tensile)}$$

Minor principal stress

$$= \frac{\sigma_1 + \sigma_2}{2} - \sqrt{\left(\frac{\sigma_1 - \sigma_2}{2}\right)^2 + \tau^2}$$

$$= \frac{80 + 20}{2} - \sqrt{\left(\frac{80 - 20}{2}\right)^2 + 40^2}$$

$$= 50 - 50 = 0.$$

From Fig. 3.17, it is clear that diagonal  $BD$  will be elongated and diagonal  $AC$  will be shortened. Hence the circle will become an ellipse whose major axis will be along  $BD$  and minor axis along  $AC$  as shown in Fig. 3.17. The major principal stress acts along  $BD$  and minor principal stress along  $AC$ .

$\therefore$  Strain along  $BD$

$$= \frac{\text{Major principal stress}}{E} - \frac{\text{Minor principal stress}}{mE}$$

$$= \frac{100}{2 \times 10^5} - \frac{0}{2 \times 10^5 \times 4}$$

$$= \frac{1}{2000}$$

$$\left( \therefore \frac{1}{m} = \frac{1}{4} \right)$$

$\therefore$  Increase in diameter along  $BD$

= Strain along  $BD \times \text{Dia. of hole}$

$$= \frac{1}{2000} \times 50 = 0.025 \text{ mm}$$

Strain along  $AC$

$$= \frac{\text{Minor principal stress}}{E} - \frac{\text{Major principal stress}}{mE}$$

$$= \frac{0}{2 \times 10^5} - \frac{100}{4 \times 2 \times 10^5}$$

$$= -\frac{1}{8000} \quad (\text{-ve sign shows that there is a decrease in length})$$

$\therefore$  Decrease in length of diameter along  $AC$

= Strain along  $AC \times \text{Dia. of hole}$

$$= \frac{1}{8000} \times 50 = 0.00625 \text{ mm}$$

$\therefore$  The circle will become an ellipse whose major axis will be  $50 + 0.025 = 50.025 \text{ mm}$  and minor axis will be

$$50 - 0.00625 = 49.99375 \text{ mm.}$$

### 3.5. GRAPHICAL METHOD FOR DETERMINING STRESSES ON OBLIQUE SECTION

Two cases are considered :

(i) A body is subjected to direct stresses in two mutually perpendicular directions when the stresses are unequal and alike.

(ii) A body is subjected to direct stresses in two mutually perpendicular directions when the stresses are equal and alike.

**3.5.1. A body is Subjected to Direct Stresses in two Mutually Perpendicular Directions when the Stresses are Unequal and alike.** Fig. 3.18 shows a rectangular bar of uniform cross-sectional area  $A$ . The bar is subjected to two tensile stresses. It is required to find the normal and tangential stresses graphically on the oblique plane  $FC$ .

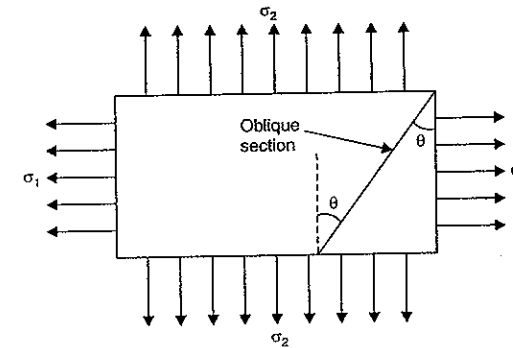

Fig. 3.18

Let  $\sigma_1$  = Major principal tensile stress,

$\sigma_2$  = Minor principal tensile stress, and

$\theta$  = Angle made by the oblique section with the axis of minor principal stress.

**Procedure.**

1. Draw two mutually perpendicular lines meeting at  $O$ .
2. Take  $OA = \text{Stress } \sigma_1$  and  $OB = \text{Stress } \sigma_2$  to some scale.

3. Draw two concentric circles with centre  $O$  and radii equal to  $OA$  and  $OB$  as shown in Fig. 3.19.

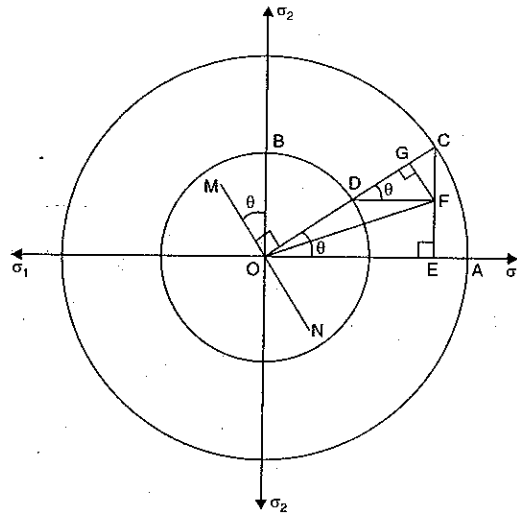

Fig. 3.19

4. Through  $O$ , draw a line  $MN$ , making an angle  $\theta$  with the axis of minor principal stress (i.e., axis of stress  $\sigma_2$ ).

5. Through  $O$ , draw a line  $ODC$  at right angles to  $MN$ , meeting the two circles at  $D$  and  $C$ .

6. From  $C$ , draw a line  $CE$  perpendicular to  $OA$ .

7. From  $D$ , draw a line  $DF$  perpendicular to  $CE$ .

8. Join  $OF$ . Then  $OF$  represents the resultant stress on the oblique plane.

9. From  $F$ , draw a line  $FG$  perpendicular to  $OC$ . Then  $OG$  represents the normal stress on the oblique plane. And  $GF$  represents the tangential stress.

$\therefore$  Normal stress =  $OG$  and

Tangential stress =  $GF$ .

**Proof.** (See Fig. 3.19).

$$CD = OC - OD$$

$$= \sigma_1 - \sigma_2 \quad (\because OC = OA = \sigma_1 \text{ and } OD = OB = \sigma_2)$$

In right angled triangle  $OEC$ ,  $\angle EOC = \theta$ .

$$\therefore \angle OCE = 90^\circ - \theta.$$

In right angled triangle  $DCF$ ,  $\angle DCF = 90^\circ - \theta$ .

$$\therefore \angle CDF = \theta$$

$$\therefore DF = CD \cos \theta = (\sigma_1 - \sigma_2) \cos \theta \quad (\because CD = \sigma_1 - \sigma_2)$$

$$CF = CD \sin \theta = (\sigma_1 - \sigma_2) \sin \theta.$$

In right angled triangle  $CGF$ ,  $\angle GCF = 90^\circ - \theta$

$$\therefore CG = CF \cos (90^\circ - \theta) = CF \sin \theta$$

$$= (\sigma_1 - \sigma_2) \sin \theta \cdot \sin \theta$$

$$= (\sigma_1 - \sigma_2) \sin^2 \theta$$

$$\therefore OG = OC - CG = \sigma_1 - (\sigma_1 - \sigma_2) \sin^2 \theta$$

$$[\because OC = \sigma_1, CG = (\sigma_1 - \sigma_2) \sin^2 \theta]$$

$$= \sigma_1 - \sigma_1 \sin^2 \theta + \sigma_2 \sin^2 \theta = \sigma_1 [1 - \sin^2 \theta] + \sigma_2 \sin^2 \theta$$

$$= \sigma_1 \cos^2 \theta + \sigma_2 \sin^2 \theta \quad (\because 1 - \sin^2 \theta = \cos^2 \theta) \quad \dots(i)$$

But from equation [3.5 (A)], normal stress across the oblique section is given by

$$\sigma_n = \sigma_1 \cos^2 \theta + \sigma_2 \sin^2 \theta \quad \dots(ii)$$

Equating equation (i) and (ii), we get

$$OG = \sigma_n = \text{Normal stress}$$

$$\text{Tangential stress, } \sigma_t = GF = CF \sin (90^\circ - \theta) = CF \cos \theta$$

$$= (\sigma_1 - \sigma_2) \sin \theta \cos \theta$$

$$= \frac{\sigma_1 - \sigma_2}{2} 2 \sin \theta \cos \theta$$

$$= \frac{\sigma_1 - \sigma_2}{2} \sin 2\theta.$$

$\therefore GF$  represents the tangential stress.

**3.5.2. Important Points.** The normal stress tangential stress and resultant stress on the oblique plane by the above method (if any one or both of  $\sigma_1$  and  $\sigma_2$  are compressive) are obtained in the same manner. Only the position of point  $F$  will change. The position of point  $F$  will be as follows :

(i) The point  $F$  will be in first quadrant if  $\sigma_1$  and  $\sigma_2$  are tensile stresses (i.e.,  $\sigma_1$  and  $\sigma_2$  are +ve).

(ii) The point  $F$  will be in second quadrant if  $\sigma_1$  is compressive and  $\sigma_2$  is tensile (i.e.,  $\sigma_1$  is -ve and  $\sigma_2$  is +ve).

(iii) The point  $F$  will be in third quadrant if  $\sigma_1$  and  $\sigma_2$  are compressive (i.e.,  $\sigma_1$  and  $\sigma_2$  are -ve).

(iv) The point  $F$  will be in fourth quadrant if  $\sigma_1$  is tensile and  $\sigma_2$  is compressive (i.e.,  $\sigma_1$  is +ve and  $\sigma_2$  is -ve).

**Problem 3.21.** Solve the problem 3.5 by graphical method.

**Sol.** The data given in problem 3.5, is

$$\sigma_1 = 120 \text{ N/mm}^2, \sigma_2 = 60 \text{ N/mm}^2, \theta = 30^\circ.$$

**Scale**

$$\text{Take } 1 \text{ cm} = 20 \text{ N/mm}^2$$

$$\text{Then } \sigma_1 = \frac{120}{20} = 6 \text{ cm and } \sigma_2 = \frac{60}{20} = 3 \text{ cm.}$$

(i) Draw two mutually perpendicular lines meeting at  $O$  as shown in Fig. 3.20.

(ii) Take  $OA = 6 \text{ cm}$  and  $OB = 3 \text{ cm}$ .

(iii) Draw two concentric circles with centre  $O$  and radii equal to  $OA = 6 \text{ cm}$  and  $OB = 3 \text{ cm}$ .

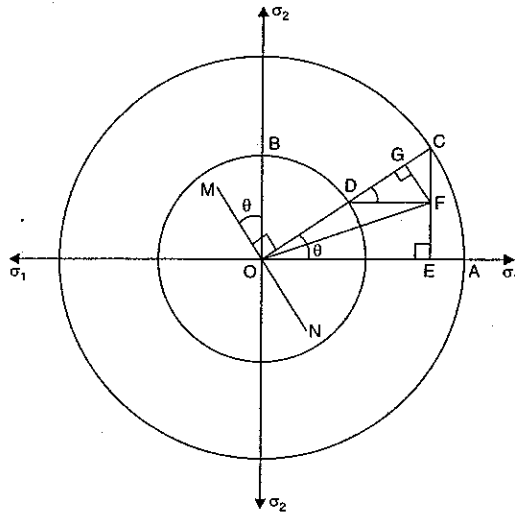

Fig. 3.20

- (iv) Draw a line  $MN$  through  $O$ , making an angle  $30^\circ$  with  $OB$ .
- (v) Through  $O$ , draw a line  $OC$  at right angles to  $MN$ , cutting the two circles at  $D$  and  $C$ . From  $C$ , draw a line  $CE$  perpendicular to  $OA$ .
- (vi) From  $D$ , draw a line  $DF$  parallel to  $OA$ , meeting the line  $CE$  at  $F$ .
- (vii) Join  $OF$ . Then  $OF$  represents the resultant stress on the oblique plane.
- (viii) From  $F$ , draw a line  $FG$  perpendicular to line  $OC$ . Then  $FG$  represents the tangential stress and  $OG$  represents the normal stress.
- (ix) Measure the lengths  $OF$ ,  $FG$  and  $OG$ .

By measurements, we get

$$\text{Length } OF = 5.411 \text{ cm}$$

$$\text{Length } FG = 1.30 \text{ cm}$$

$$\text{Length } OG = 5.25 \text{ cm.}$$

$$\begin{aligned} \therefore \text{Resultant stress, } \sigma_R &= \text{Length } OF \times \text{Scale} \\ &= 5.41 \times 20 \\ &= 108.2 \text{ N/mm}^2. \text{ Ans.} \end{aligned} \quad (\because 1 \text{ cm} = 20 \text{ N/mm}^2)$$

$$\text{Normal stress, } \sigma_n = \text{Length } OG \times 20 \text{ N/mm}^2 = 5.25 \times 20 = 105 \text{ N/mm}^2. \text{ Ans.}$$

$$\text{Tangential stress, } \sigma_t = \text{Length } FG \times 20 \text{ N/mm}^2 = 1.30 \times 20 = 26 \text{ N/mm}^2. \text{ Ans.}$$

**Problem 3.22.** Solve the problem 3.6 by graphical method.

**Sol.** Given :

The data given in problem 3.6, is

$$\sigma_1 = 200 \text{ N/mm}^2$$

$$\sigma_2 = -100 \text{ N/mm}^2$$

$$\theta = 30^\circ$$

As  $\sigma_1$  is +ve and  $\sigma_2$  is -ve, the point  $F$  will be in fourth quadrant (see Art. 3.5.2) on page 125).

**Scale.** Take  $1 \text{ cm} = 20 \text{ N/mm}^2$

$$\text{Then } \sigma_1 = \frac{200}{20} = 10 \text{ cm and } \sigma_2 = \frac{100}{20} = 5 \text{ cm.}$$

- (i) Draw two mutually perpendicular lines meeting at  $O$  as shown in Fig. 3.21.

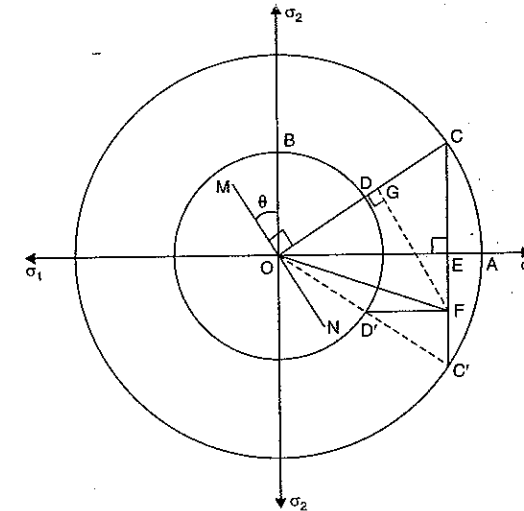

Fig. 3.21

- (ii) Take  $OA = 10 \text{ cm}$  and  $OB = 5 \text{ cm}$ .
- (iii) Draw two concentric circles with centre  $O$  and radii equal to  $OA = 10 \text{ cm}$  and  $OB = 5 \text{ cm}$ .
- (iv) Draw a line  $MN$  through  $O$  at an angle of  $30^\circ$  with the line  $OB$ .
- (v) Through  $O$ , draw a line  $OC$  at right angles to  $MN$ , cutting the two circles at  $C$  and  $D$ .
- (vi) From  $C$ , draw a line  $CE$  perpendicular to  $OA$ . Produce the line  $CE$  upto  $C'$ . Join the line  $OC'$ , cutting the circle of radius  $OB$  at  $D'$ .
- (vii) As the point  $F$  will lie in the fourth quadrant, the point  $F$  will be obtained by drawing a line  $D'F$  parallel to  $OA$ .
- (viii) Join  $OF$ . Then  $OF$  represents the resultant stress.
- (ix) From  $F$ , draw  $FG$  perpendicular to line  $OC$ . Then  $OG$  represents the normal stress, and  $GF$  represents the tangential stress on the oblique plane.
- (x) Measure the lengths  $OF$ ,  $OG$  and  $GF$ .

From Fig. 3.21, by measurements,

$$\text{Length } OF = 9.0 \text{ cm}$$

$$\text{Length } OG = 6.25 \text{ cm}$$

$$\text{Length } GF = 6.50 \text{ cm.}$$

$$\begin{aligned} \therefore \text{Resultant stress} &= \text{Length } OF \times \text{Scale} \\ &= 9.0 \times 20 \\ &= 180 \text{ N/mm}^2. \text{ Ans.} \end{aligned} \quad (\because 1 \text{ cm} = 20 \text{ N/mm}^2)$$

$$\begin{aligned} \text{Normal stress} &= \text{Length } OG \times \text{Scale} = 6.25 \times 20 = 125 \text{ N/mm}^2. \text{ Ans.} \\ \text{Tangential stress} &= \text{Length } GF \times \text{Scale} = 6.50 \times 20 = 130 \text{ N/mm}^2. \text{ Ans.} \end{aligned}$$

### 3.6. MOHR'S CIRCLE

Mohr's circle is a graphical method of finding normal, tangential and resultant stresses on an oblique plane. Mohr's circle will be drawn for the following cases :

(i) A body subjected to two mutually perpendicular principal tensile stresses of unequal intensities.

(ii) A body subjected to two mutually perpendicular principal stresses which are unequal and unlike (i.e., one is tensile and other is compressive).

(iii) A body subjected to two mutually perpendicular principal tensile stresses accompanied by a simple shear stress.

**3.6.1. Mohr's Circle when a Body is Subjected to two Mutually Perpendicular Principal Tensile Stresses of Unequal Intensities.** Consider a rectangular body subjected to two mutually perpendicular principal tensile stresses of unequal intensities. It is required to find the resultant stress on an oblique plane.

Let  $\sigma_1$  = Major tensile stress  
 $\sigma_2$  = Minor tensile stress, and  
 $\theta$  = Angle made by the oblique plane with the axis of minor tensile stress.

Mohr's circle is drawn as : (See Fig. 3.22).

Take any point A and draw a horizontal line through A. Take  $AB = \sigma_1$  and  $AC = \sigma_2$  towards right from A to some suitable scale. With BC as diameter describe a circle. Let O is the centre of the circle. Now through O, draw a line OE marking an angle  $2\theta$  with OB.

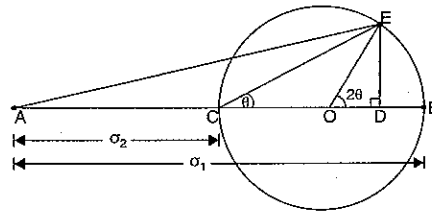

Fig. 3.22

From E, draw ED perpendicular on AB. Join AE. Then the normal and tangential stresses on the oblique plane are given by AD and ED respectively. The resultant stress on the oblique plane is given by AE.

From Fig. 3.22, we have

Length AD = Normal stress on oblique plane  
 Length ED = Tangential stress on oblique plane  
 Length AE = Resultant stress on oblique plane.

Radius of Mohr's circle =  $\frac{\sigma_1 - \sigma_2}{2}$

Angle  $\phi$  = obliquity.

**Proof.** (See Fig. 3.22)

$$CO = OB = OE = \text{Radius of Mohr's circle} = \frac{\sigma_1 - \sigma_2}{2}$$

$$\begin{aligned} \therefore AO &= AC + CO \\ &= \sigma_2 + \frac{\sigma_1 - \sigma_2}{2} = \frac{2\sigma_2 + \sigma_1 - \sigma_2}{2} = \frac{\sigma_1 + \sigma_2}{2} \\ OD &= OE \cos 2\theta \\ &= \frac{\sigma_1 - \sigma_2}{2} \cos 2\theta \end{aligned} \quad \left( \because OE = \frac{\sigma_1 - \sigma_2}{2} \right)$$

$$\begin{aligned} \therefore AD &= AO + OD \\ &= \frac{\sigma_1 + \sigma_2}{2} + \frac{\sigma_1 - \sigma_2}{2} \cos 2\theta \\ &= \sigma_n \text{ or Normal stress} \end{aligned}$$

and  $ED = OE \sin 2\theta$

$$\begin{aligned} &= \frac{\sigma_1 - \sigma_2}{2} \sin 2\theta \\ &= \sigma_t \text{ or Tangential stress.} \end{aligned}$$

**Important points.** (See Fig. 3.22)

(i) Normal stress is along the line ACB. Hence maximum normal stress will be when point E is at B. And minimum normal stress will be when point E is at C. Hence maximum normal stress =  $AB = \sigma_1$  and minimum normal stress =  $AB = \sigma_2$ .

(ii) Tangential stress (or shear stress) is along a line which is perpendicular to line CB. Hence maximum shear stress will be when perpendicular to line CB is drawn from point O. Then maximum shear stress will be equal to the radius of the Mohr's circle.

$$\therefore (\sigma_t)_{\max} = \frac{\sigma_1 - \sigma_2}{2}$$

(iii) When the point E is at B or at C, the shear stress will be zero.

(iv) The angle  $\phi$  (which is known as angle of obliquity) will be maximum, when the line AE is tangent to the Mohr's circle.

**Problem 3.23.** Solve problem 3.5 by using Mohr's circle method.

**Sol.** The data is given in problem 3.5, is

$$\sigma_1 = 120 \text{ N/mm}^2 \text{ (tensile)}$$

$$\sigma_2 = 60 \text{ N/mm}^2 \text{ (tensile)}$$

$$\theta = 30^\circ$$

**Scale.** Let 1 cm = 10 N/mm<sup>2</sup>

Then  $\sigma_1 = \frac{120}{10} = 12 \text{ cm}$

and  $\sigma_2 = \frac{60}{10} = 6 \text{ cm}$

Mohr's circle is drawn as : (See Fig. 3.23).

Take any point A and draw a horizontal line through A. Take  $AB = \sigma_1 = 12 \text{ cm}$  and  $AC = \sigma_2 = 6 \text{ cm}$ . With BC as diameter (i.e.,  $BC = 12 - 6 = 6 \text{ cm}$ ) describe a circle. Let O is the centre of the circle. Through O, draw a line OE making an

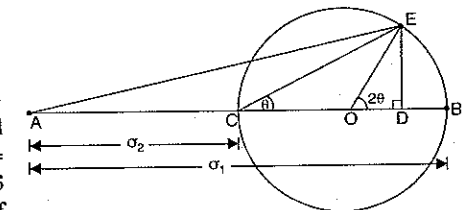

Fig. 3.23



angle  $2\theta$  (i.e.,  $2 \times 30 = 60^\circ$ ) with  $OB$ . From  $E$ , draw  $ED$  perpendicular to  $CB$ . Join  $AE$ . Measure lengths  $AD$ ,  $ED$  and  $AE$ .

By measurements :

$$\text{Length } AD = 10.50 \text{ cm}$$

$$\text{Length } ED = 2.60 \text{ cm}$$

$$\text{Length } AE = 10.82 \text{ cm}$$

$$\begin{aligned} \text{Then normal stress} &= \text{Length } AD \times \text{Scale} \\ &= 10.50 \times 10 = 105 \text{ N/mm}^2. \text{ Ans.} \end{aligned}$$

$$\begin{aligned} \text{Tangential or shear stress} &= \text{Length } ED \times \text{Scale} \\ &= 2.60 \times 10 = 26 \text{ N/mm}^2. \text{ Ans.} \end{aligned}$$

$$\begin{aligned} \text{Resultant stress} &= \text{Length } AE \times \text{Scale} \\ &= 10.82 \times 10 = 108.2 \text{ N/mm}^2. \text{ Ans.} \end{aligned}$$

**3.6.2. Mohr's Circle when a Body is Subjected to two Mutually Perpendicular Principal Stresses which are Unequal and Unlike (i.e., one is Tensile and other is Compressive).** Consider a rectangular body subjected to two mutually perpendicular principal stresses which are unequal and one of them is tensile and the other is compressive. It is required to find the resultant stress on an oblique plane.

Let  $\sigma_1$  = Major principal tensile stress,  
 $\sigma_2$  = Minor principal compressive stress, and  
 $\theta$  = Angle made by the oblique plane with the axis  
of minor principal stress.

Mohr's circle is drawn as : (See Fig. 3.24)

Take any point  $A$  and draw a horizontal line through  $A$  on both sides of  $A$  as shown in Fig. 3.24. Take  $AB = \sigma_1$  (+) towards right of  $A$  and  $AC = \sigma_2$  (-) towards left of  $A$  to some suitable scale. Bisect  $BC$  at  $O$ . With  $O$  as centre and radius equal to  $CO$  or  $OB$ , draw a circle. Through  $O$  draw a line  $OE$  making an angle  $2\theta$  with  $OB$ .

From  $E$ , draw  $ED$  perpendicular to  $AB$ . Join  $AE$  and  $CE$ . Then normal and shear stress (i.e., tangential stress) on the oblique plane are given by  $AD$  and  $ED$ . Length  $AE$  represents the resultant stress on the oblique plane.

$\therefore$  From Fig. 3.24, we have

Length  $AD$  = Normal stress on oblique plane,

Length  $ED$  = Shear stress on oblique plane,

Length  $AE$  = Resultant stress on oblique plane, and

Angle  $\phi$  = Obliquity.

$$\text{Radius of Mohr's circle} = CO \text{ or } OB = \frac{\sigma_1 + \sigma_2}{2}$$

**Proof.** (See Fig. 3.24).

$$CO = OB = OE = \text{Radius of Mohr's circle}$$

$$= \frac{\sigma_1 + \sigma_2}{2}$$

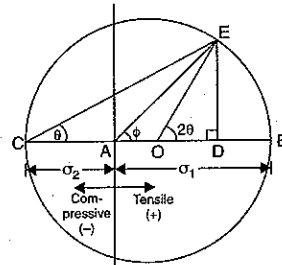

Fig. 3.24

$$AO = OC - AC$$

$$= \frac{\sigma_1 + \sigma_2}{2} - \sigma_2 = \frac{\sigma_1 + \sigma_2 - 2\sigma_2}{2} = \frac{\sigma_1 - \sigma_2}{2}$$

$\therefore$

$$AD = AO + OD$$

$$= AO + OB \cos 2\theta$$

$$(\because OD = OE \cos 2\theta)$$

$$= \frac{\sigma_1 - \sigma_2}{2} + \frac{\sigma_1 + \sigma_2}{2} \cos 2\theta$$

$$(\because OE = \text{Radius} = \frac{\sigma_1 + \sigma_2}{2})$$

$$= \sigma_n \text{ or Normal stress}$$

and

$$ED = OE \sin 2\theta$$

$$= \frac{\sigma_1 + \sigma_2}{2} \sin 2\theta$$

$$(\because OE = \frac{\sigma_1 + \sigma_2}{2})$$

$$= \sigma_t \text{ or Tangential (or shear) stress.}$$

**Problem 3.24.** Solve problem 3.6 by using Mohr's circle method.

**Sol.** Given : The data given in problem 3.6, is

$$\sigma_1 = 200 \text{ N/mm}^2$$

$$\sigma_2 = -100 \text{ N/mm}^2 \text{ (compressive)}$$

$$\theta = 30^\circ$$

It is required to determine the resultant stress and the maximum shear stress by Mohr's circle method. First choose a suitable scale.

Let 1 cm represents 20 N/mm<sup>2</sup>.

$$\text{Then } \sigma_1 = \frac{200}{20} = 10 \text{ cm}$$

and

$$\sigma_2 = \frac{-100}{20} = -5 \text{ cm}$$

Mohr's circle is drawn as given in Fig. 3.25.

Take any point  $A$  and draw a horizontal line through  $A$  on both sides of  $A$ . Take  $AB = \sigma_1 = 10 \text{ cm}$  towards right of  $A$  and  $AC = \sigma_2 = -5 \text{ cm}$  towards left of  $A$ . Bisect  $BC$  at  $O$ . With  $O$  as centre and radius equal to  $CO$  or  $OB$ , draw a circle. Through  $O$  draw a line  $OE$  making an angle  $2\theta$  (i.e.,  $2 \times 30^\circ = 60^\circ$ ) with  $OB$ . From  $E$ , draw  $ED$  perpendicular to  $AB$ . Join  $AE$  and  $CE$ . Then  $AE$  represents the resultant stress and angle  $\phi$  represents the obliquity.

By measurement from Fig. 3.25, we have

$$\text{Length } AE = 9.0 \text{ cm}$$

$$\text{Length } AD = 6.25 \text{ cm and length } ED = 6.5 \text{ cm}$$

$$\text{Angle } \phi = 46^\circ$$

$$\begin{aligned} \therefore \text{Resultant stress} &= \text{Length } AE \times \text{Scale} \\ &= 9.0 \times 20 = 180 \text{ N/mm}^2. \text{ Ans.} \end{aligned}$$

Angle made by the resultant stress with the normal of the inclined plane =  $\phi = 46^\circ$ . Ans.

$$\text{Normal stress} = \text{Length } AD \times 20$$

$$= 6.25 \times 20 = 125 \text{ N/mm}^2$$

$$\text{Shear stress} = \text{Length } ED \times 20$$

$$= 6.5 \times 20 = 130 \text{ N/mm}^2.$$

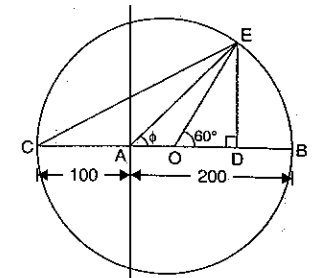

Fig. 3.25

**Maximum shear stress.** Shear stress is along a line which is perpendicular to the line  $AB$ . Hence maximum shear stress will be when perpendicular to line  $AB$  is drawn from point  $O$ . Then maximum shear stress will be equal to the radius of Mohr's circle.

∴ Maximum shear stress = Radius of Mohr's circle

$$= \frac{\sigma_1 + \sigma_2}{2} = \frac{200 + 100}{2} = 150 \text{ N/mm}^2. \text{ Ans.}$$

**3.6.3. Mohr's Circle when a Body is Subjected to two Mutually Perpendicular Principal Tensile Stresses Accompanied by a Simple Shear Stress.** Consider a rectangular body subjected to two mutually perpendicular principal tensile stresses of unequal intensities accompanied by a simple shear stress. It is required to find the resultant stress on an oblique plane as shown in Fig. 3.26.

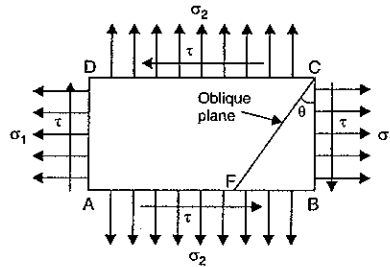

Fig. 3.26

- Let  $\sigma_1$  = Major tensile stress
- $\sigma_2$  = Minor tensile stress
- $\tau$  = Shear stress across face  $BC$  and  $AD$
- $\theta$  = Angle made by the oblique plane with the plane of major tensile stress.

According to the principal of shear stress, the faces  $AB$  and  $CD$  will also be subjected to a shear stress of  $\tau$ .

**Mohr's circle** is drawn as given in Fig. 3.27.

Take any point  $A$  and draw a horizontal line through  $A$ .

Take  $AB = \sigma_1$  and  $AC = \sigma_2$  towards right of  $A$  to some suitable scale. Draw perpendiculars at  $B$  and  $C$  and cut off  $BF$  and  $CG$  equal to shear stress  $\tau$  to the same scale. Bisect  $BC$  at  $O$ . Now with  $O$  as centre and radius equal to  $OG$  or  $OF$  draw a circle. Through  $O$ , draw a line  $OE$  making an angle of  $2\theta$  with  $OF$  as shown in Fig. 3.27. From  $E$ , draw  $ED$  perpendicular to  $CB$ . Join  $AE$ . Then length  $AE$  represents the resultant stress on the given oblique plane. And lengths  $AD$  and  $ED$  represents the normal stress and tangential stress respectively.

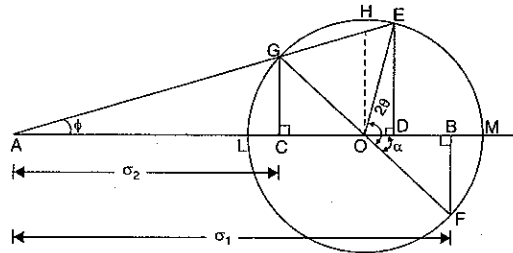

Fig. 3.27

Hence from Fig. 3.27, we have

Length  $AE$  = Resultant stress on the oblique plane

Length  $AD$  = Normal stress on the oblique plane

Length  $ED$  = Shear stress on the oblique plane.

**Proof.** (See Fig. 3.27).

$$CO = \frac{1}{2} CB = \frac{1}{2} [\sigma_1 - \sigma_2] \quad (\because CB = \sigma_1 - \sigma_2)$$

$$AO = AC + CO = \sigma_2 + \frac{1}{2} [\sigma_1 - \sigma_2]$$

$$= \frac{2\sigma_2 + \sigma_1 - \sigma_2}{2} = \frac{\sigma_1 + \sigma_2}{2}$$

$$AD = AO + OD$$

$$= \frac{\sigma_1 + \sigma_2}{2} + OE \cos (2\theta - \alpha) \quad [\because OD = OE \cos (2\theta - \alpha)]$$

$$= \frac{\sigma_1 + \sigma_2}{2} + OE [\cos 2\theta \cos \alpha + \sin 2\theta \sin \alpha]$$

$$= \frac{\sigma_1 + \sigma_2}{2} + OE \cos 2\theta \cos \alpha + OE \sin 2\theta \sin \alpha$$

$$= \frac{\sigma_1 + \sigma_2}{2} + OE \cos \alpha \cdot \cos 2\theta + OE \sin \alpha \cdot \sin 2\theta$$

$$= \frac{\sigma_1 + \sigma_2}{2} + OF \cos \alpha \cdot \cos 2\theta + OF \sin \alpha \cdot \sin 2\theta$$

$$(\because OE = OF = \text{Radius})$$

$$= \frac{\sigma_1 + \sigma_2}{2} + OB \cos 2\theta + BF \sin 2\theta$$

$$(\because OF \cos \alpha = OB, OF \sin \alpha = BF)$$

$$= \frac{\sigma_1 + \sigma_2}{2} + CO \cos 2\theta + \tau \sin 2\theta \quad (\because OB = CO, BF = \tau)$$

$$= \frac{\sigma_1 + \sigma_2}{2} + \frac{\sigma_1 - \sigma_2}{2} \cos 2\theta + \tau \sin 2\theta \quad (\because CO = \frac{\sigma_1 - \sigma_2}{2})$$

$$= \sigma_n \text{ or Normal stress}$$

Now

$$ED = OE \sin (2\theta - \alpha) = OE (\sin 2\theta \cos \alpha - \cos 2\theta \sin \alpha)$$

$$= OE \sin 2\theta \cos \alpha - OE \cos 2\theta \sin \alpha$$

$$= OE \cos \alpha \cdot \sin 2\theta - OE \sin \alpha \cdot \cos 2\theta$$

$$(\because OE = OF = \text{Radius})$$

$$= OB \cdot \sin 2\theta - BF \cos 2\theta \quad (\because OF \cos \alpha = OB, OF \sin \alpha = BF)$$

$$= CO \cdot \sin 2\theta - \tau \cos 2\theta \quad (\because OB = CO, BF = \tau)$$

$$= \frac{\sigma_1 - \sigma_2}{2} \sin 2\theta - \tau \cos 2\theta \quad (\because CO = \frac{\sigma_1 - \sigma_2}{2})$$

$$= \sigma_t \text{ or Tangential stress.}$$

**Maximum and minimum value of normal stress.** In Fig. 3.27, the normal stress is given by  $AD$ . Hence the maximum value of  $AD$  will be when  $D$  coincides with  $M$  and minimum value of  $AD$  will be when  $D$  coincides with  $L$ .

∴ Maximum value of normal stress,

$$(\sigma_n)_{\max} = AM = AO + OM$$

$$= \frac{\sigma_1 + \sigma_2}{2} + OF \quad (\because AO = \frac{\sigma_1 + \sigma_2}{2}, OM = OF = \text{Radius})$$

$$= \frac{\sigma_1 + \sigma_2}{2} + \sqrt{OB^2 + BF^2} \quad (\because \text{In triangle } OBF, OF = \sqrt{OB^2 + BF^2})$$

$$= \frac{\sigma_1 + \sigma_2}{2} + \sqrt{\left(\frac{\sigma_1 - \sigma_2}{2}\right)^2 + \tau^2} \quad (\because OB = \frac{\sigma_1 - \sigma_2}{2}, BF = \tau)$$

Minimum value of normal stress,

$$\begin{aligned} (\sigma_n)_{\min} &= AL = AO - LO \\ &= \frac{\sigma_1 + \sigma_2}{2} - OF \quad (\because LO = OF = \text{Radius}) \\ &= \frac{\sigma_1 + \sigma_2}{2} - \sqrt{\left(\frac{\sigma_1 - \sigma_2}{2}\right)^2 + \tau^2} \end{aligned}$$

(i) For maximum normal stress, the point  $D$  coincides with  $M$ . But when the point  $D$  coincides with  $M$ , the point  $E$  also coincides with  $M$ . Hence for maximum value of normal stress,

$$\text{Angle } 2\theta = \alpha \quad (\because \text{Line } OE \text{ coincides with line } OM)$$

$$\therefore \theta = \frac{\alpha}{2} \quad \dots(i)$$

$$\begin{aligned} \text{Also } \tan 2\theta &= \tan \alpha = \frac{BF}{OB} = \frac{\tau}{\frac{\sigma_1 - \sigma_2}{2}} \\ &= \frac{2\tau}{\sigma_1 - \sigma_2} \end{aligned} \quad \left( \because BF = \tau, OB = \frac{\sigma_1 - \sigma_2}{2} \right)$$

(ii) For maximum and minimum normal stresses, the shear stress is zero and hence the planes, on which maximum and minimum normal stresses act, are known as *principal planes* and the stresses are known as *principal stresses*.

(iii) For minimum normal stress, the point  $D$  coincides with point  $L$ . But when the point  $D$  coincides with  $L$ , the point  $E$  also coincides with  $L$ . Then

$$\text{Angle } 2\theta = \pi + \alpha \quad (\because \text{Line } OE \text{ coincides with line } OL)$$

$$\therefore \theta = \frac{\pi + \alpha}{2} \quad \dots(ii)$$

From equations (i) and (ii), it is clear that the plane of minimum normal stress is inclined at an angle  $90^\circ$  to the plane of maximum normal stress.

**Maximum value of shear stress.** Shear stress is given by  $ED$ . Hence maximum value of  $ED$  will be when  $E$  coincides with  $G$ , and  $D$  coincides with  $O$ .

$\therefore$  Maximum shear stress,

$$\begin{aligned} (\sigma_v)_{\max} &= OH = OF \quad (\because OH = OF = \text{radius}) \\ &= \sqrt{OB^2 + BF^2} \quad (\because \text{In triangle } OBF, OF = \sqrt{OB^2 + BF^2}) \\ &= \sqrt{\left(\frac{\sigma_1 - \sigma_2}{2}\right)^2 + \tau^2} \quad \left( \because OB = \frac{\sigma_1 - \sigma_2}{2}, BF = \tau \right) \end{aligned}$$

**Problem 3.25.** A point in a strained material is subjected to stresses shown in Fig. 3.28. Using Mohr's circle method, determine the normal and tangential stresses across the oblique plane. Check the answer analytically.

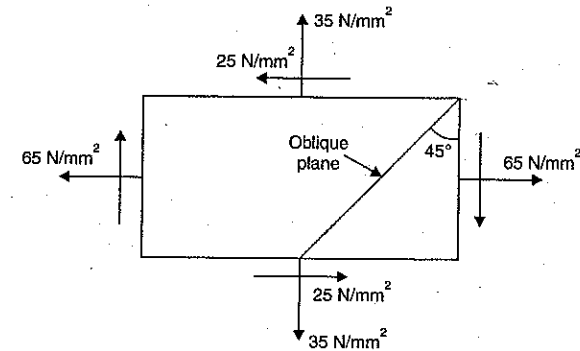

Fig. 3.28

**Sol. Given :**

Major principal stress,  $\sigma_1 = 65 \text{ N/mm}^2$

Minor principal stress,  $\sigma_2 = 35 \text{ N/mm}^2$

Shear stress,  $\tau = 25 \text{ N/mm}^2$

Angle of oblique plane,  $\theta = 45^\circ$ .

**Mohr's circle method**

Let  $1 \text{ cm} = 10 \text{ N/mm}^2$

Then  $\sigma_1 = \frac{65}{10} = 6.5 \text{ cm}$ ,

$\sigma_2 = \frac{35}{10} = 3.5 \text{ cm}$  and  $\tau = \frac{25}{10} = 2.5 \text{ cm}$

Mohr's circle is drawn as given in Fig. 3.29.

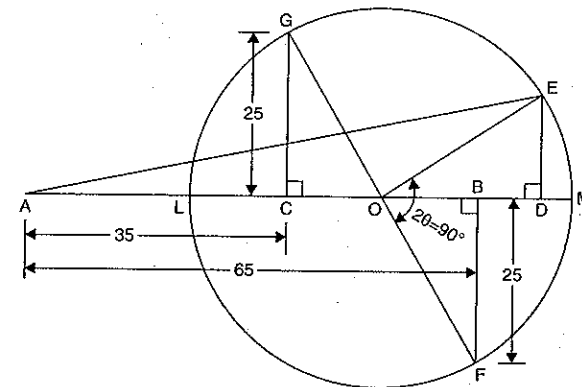

Fig. 3.29

Take any point  $A$  and draw a horizontal line through  $A$ . Take  $AB = \sigma_1 = 6.5 \text{ cm}$  and  $AC = \sigma_2 = 3.5 \text{ cm}$  towards right of  $A$ . Draw perpendicular at  $B$  and  $C$  and cut off  $BF$  and  $CG$

equal to shear stress  $\tau = 2.5$  cm. Bisect  $BC$  at  $O$ . Now with  $O$  as centre and radius equal to  $OF$  (or  $OG$ ) draw a circle. Through  $O$ , draw a line  $OE$  making an angle of  $2\theta$  (i.e.,  $2 \times 45^\circ = 90^\circ$ ) with  $OF$  as shown in Fig. 3.29. From  $E$ , draw  $ED$  perpendicular to  $AB$  produced. Join  $AE$ . Then length  $AD$  represents the normal stress and length  $ED$  represents the shear stress.

By measurements, length  $AD = 7.5$  cm and length  $ED = 1.5$  cm.

$\therefore$  Normal stress ( $\sigma_n$ ) = Length  $AD \times$  Scale =  $7.5 \times 10 = 75 \text{ N/mm}^2$ . Ans.  
 ( $\because 1 \text{ cm} = 10 \text{ N/mm}^2$ )

And tangential stress ( $\sigma_t$ ) = Length  $ED \times$  Scale =  $1.5 \times 10 = 15 \text{ N/mm}^2$ . Ans.

**Analytical Answers**

Normal stress ( $\sigma_n$ ) is given by equation (3.12).

$\therefore$  Using equation (3.12),

$$\begin{aligned} \sigma_n &= \frac{\sigma_1 + \sigma_2}{2} + \frac{\sigma_1 - \sigma_2}{2} \cos 2\theta + \tau \sin 2\theta \\ &= \frac{65 + 35}{2} + \frac{65 - 35}{2} \cos (2 \times 45^\circ) + 25 \sin (2 \times 45^\circ) \\ &= 50 + 15 \cos 90^\circ + 25 \sin 90^\circ \\ &= 50 + 15 \times 0 + 25 \times 1 \quad (\because \cos 90^\circ = 0, \sin 90^\circ = 1) \\ &= 50 + 0 + 25 = 75 \text{ N/mm}^2. \text{ Ans.} \end{aligned}$$

Tangential stress is given by equation (3.13)

$\therefore$  Using equation (3.13),

$$\begin{aligned} \sigma_t &= \frac{\sigma_1 - \sigma_2}{2} \sin 2\theta - \tau \cos 2\theta \\ &= \frac{65 - 35}{2} \sin (2 \times 45^\circ) - 25 \cos (2 \times 45^\circ) \\ &= 15 \sin 90^\circ - 25 \cos 90^\circ = 15 \times 1 - 25 \times 0 = 15 - 0 \\ &= 15 \text{ N/mm}^2. \text{ Ans.} \end{aligned}$$

**Problem 3.26.** At a certain point in a strained material, the intensities of stresses on two planes at right angles to each other are  $20 \text{ N/mm}^2$  and  $10 \text{ N/mm}^2$  both tensile. They are accompanied by a shear stress of magnitude  $10 \text{ N/mm}^2$ . Find graphically or otherwise, the location of principal planes and evaluate the principal stresses.

**Sol.** Given :

Major tensile stress,  $\sigma_1 = 20 \text{ N/mm}^2$

Minor tensile stress,  $\sigma_2 = 10 \text{ N/mm}^2$

Shear stress,  $\tau = 10 \text{ N/mm}^2$

This problem may be solved analytically or graphically. Here we shall solve it graphically (i.e., by Mohr's circle method).

**Scale.** Take  $1 \text{ cm} = 2 \text{ N/mm}^2$

Then  $\sigma_1 = \frac{20}{2} = 10 \text{ cm}$ ,  $\sigma_2 = \frac{10}{2} = 5 \text{ cm}$

and  $\tau = \frac{10}{2} = 5 \text{ cm}$ .

Mohr's circle is drawn as given in Fig. 3.30.

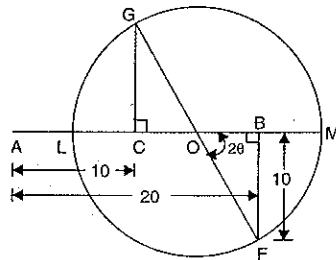

Fig. 3.30

Take any point  $A$  and draw a horizontal line through  $A$ . Take  $AB = \sigma_1 = 10 \text{ cm}$  and  $AC = \sigma_2 = 5 \text{ cm}$  towards right side of  $A$ . Draw perpendiculars at  $B$  and  $C$  and cut off  $BF = CG = \tau = 5 \text{ cm}$ . Bisect  $BC$  at  $O$ . Now with  $O$  as centre and radius equal to  $OG$  (or  $OF$ ), draw a circle cutting the horizontal line through  $A$ , at  $L$  and  $M$  as shown in Fig. 3.30. Then  $AM$  and  $AL$  represent the major principal and minor principal stresses.

By measurements, we have

Length  $AM = 13.1 \text{ cm}$  and Length  $AL = 1.91 \text{ cm}$

$\angle FOB$  (or  $2\theta$ ) =  $63.7^\circ$ .

$\therefore$  Major principal stress = Length  $AM \times$  Scale  
 =  $13.1 \times 2 \text{ N/mm}^2$  ( $\because 1 \text{ cm} = 2 \text{ N/mm}^2$ )  
 =  $26.2 \text{ N/mm}^2$ . Ans.

Minor principal stress = Length  $AL \times$  Scale  
 =  $1.91 \times 2 = 3.82 \text{ N/mm}^2$ . Ans.

**Location of principal planes**

$2\theta = 63.7^\circ$

$\therefore \theta = \frac{63.7^\circ}{2} = 31.85^\circ$ . Ans.

The second principal plane is given by

$\theta + 90^\circ$  or  $31.85^\circ + 90^\circ$  or  $121.85^\circ$ . Ans.

**Problem 3.27.** An elemental cube is subjected to tensile stresses of  $30 \text{ N/mm}^2$  and  $10 \text{ N/mm}^2$  acting on two mutually perpendicular planes and a shear stress of  $10 \text{ N/mm}^2$  on these planes. Draw the Mohr's circle of stresses and hence or otherwise determine the magnitudes and directions of principal stresses and also the greatest shear stress.

**Sol.** Given :

Major tensile stress,  $\sigma_1 = 30 \text{ N/mm}^2$

Minor tensile stress,  $\sigma_2 = 10 \text{ N/mm}^2$

Shear stress,  $\tau = 10 \text{ N/mm}^2$

**Scale.** Take  $1 \text{ cm} = 2 \text{ N/mm}^2$

Then  $\sigma_1 = \frac{30}{2} = 15 \text{ cm}$

$\sigma_2 = \frac{10}{2} = 5 \text{ cm}$  and  $\tau = \frac{10}{2} = 5 \text{ cm}$

Mohr's circle of stresses is drawn as given in Fig. 3.31.

Take any point  $A$  and draw a horizontal line through  $A$ .

Take  $AB = \sigma_1 = 15 \text{ cm}$  and  $AC = \sigma_2 = 5 \text{ cm}$  towards right side of  $A$ . Draw perpendiculars at  $B$  and  $C$  and cut off  $BF = CG = \tau = 5 \text{ cm}$ . Bisect  $BC$  at  $O$ . Now with  $O$  as centre and radius equal to  $OG$  (or  $OF$ ), draw a circle cutting the horizontal line through  $A$  at  $L$  and  $M$  as shown in Fig. 3.31. Then  $AM$  and  $AL$  represents the major and minor principal stresses respectively. And  $OH$  represents the maximum shear stress.

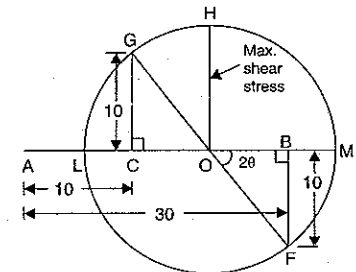

Fig. 3.31

By measurements, we have

$$\text{Length } AM = 17.1 \text{ cm}$$

$$\text{Length } AL = 2.93 \text{ cm}$$

$$\begin{aligned} \text{Length } OH &= \text{Radius of Mohr's circle} \\ &= 7.05 \text{ cm} \end{aligned}$$

$$\angle FOB \text{ (or } 2\theta) = 45^\circ.$$

$\therefore$  Major principal stress

$$= \text{Length } AM \times \text{Scale}$$

$$= 17.1 \times 2$$

$$= 34.2 \text{ N/mm}^2. \text{ Ans.}$$

Minor principal stress = Length  $AL \times$  Scale

$$= 2.93 \times 2$$

$$= 5.86 \text{ N/mm}^2. \text{ Ans.}$$

$$\angle FOB \text{ or } 2\theta = 45^\circ$$

$$\therefore \theta = \frac{45}{2} = 22.5^\circ. \text{ Ans.}$$

The second principal plane is given by  $\theta + 90^\circ$ .

$$\therefore \text{Second principal plane} = 22.5 + 90 = 112.5^\circ. \text{ Ans.}$$

The greatest shear stress = Length  $OH \times$  Scale

$$= 7.05 \times 20 = 14.1 \text{ N/mm}^2. \text{ Ans.}$$

### HIGHLIGHTS

1. The planes, which have no shear stress, are known as principal planes.
2. The stresses, acting on principal planes, are known as principal stresses.
3. Analytical and graphical methods are used for finding the stresses on an oblique section.
4. When a member is subjected to a direct stress ( $\sigma$ ) in one plane, then the stresses on an oblique plane (which is inclined at an angle  $\theta$  with the normal cross-section) are given by :

$$\text{Normal stress, } \sigma_n = \sigma \cos^2 \theta$$

$$\text{Tangential stress, } \sigma_t = \frac{\sigma}{2} \sin 2\theta$$

$$\text{Max. normal stress} = \sigma$$

$$\text{Max. shear stress} = \frac{\sigma}{2}$$

5. When a member is subjected to two like direct stresses in two mutually perpendicular directions, then the stresses on an oblique plane inclined at an angle  $\theta$  with the axis of the minor stress (or with the plane of major stress) are given by :

$$\text{Normal stress, } \sigma_n = \frac{\sigma_1 + \sigma_2}{2} + \frac{\sigma_1 - \sigma_2}{2} \cos 2\theta.$$

$$\text{Tangential stress, } \sigma_t = \frac{\sigma_1 - \sigma_2}{2} \sin 2\theta$$

$$\text{Resultant stress, } \sigma_R = \sqrt{\sigma_n^2 + \sigma_t^2}.$$

6. The angle made by the resultant stress with the normal of the oblique plane, is known as obliquity.

It is denoted by  $\phi$ . Mathematically,  $\tan \phi = \frac{\sigma_t}{\sigma_n}$ .

7. When a member is subjected to a simple shear stress ( $\tau$ ), then the stresses on an oblique plane are given as :

$$\text{Normal stress, } \sigma_n = \tau \sin 2\theta$$

$$\text{Tangential stress, } \sigma_t = -\tau \cos 2\theta.$$

8. When a member is subjected to two direct stresses ( $\sigma_1, \sigma_2$ ) in two mutually perpendicular directions accompanied by a simple shear stress ( $\tau$ ), then the stresses, on an oblique plane inclined at an angle  $\theta$  with the axis of minor stress, are given by :

$$\text{Normal stress, } \sigma_n = \frac{\sigma_1 + \sigma_2}{2} + \frac{\sigma_1 - \sigma_2}{2} \cos 2\theta + \tau \sin 2\theta.$$

$$\text{Tangential stress, } \sigma_t = \frac{\sigma_1 - \sigma_2}{2} \sin 2\theta - \tau \cos 2\theta$$

$$(a) \text{ Position of principal planes is given by } \tan 2\theta = \frac{2\tau}{\sigma_1 - \sigma_2}$$

$$(b) \text{ Major principal stress} = \frac{\sigma_1 + \sigma_2}{2} + \sqrt{\left(\frac{\sigma_1 - \sigma_2}{2}\right)^2 + \tau^2}$$

$$(c) \text{ Minor principal stress} = \frac{\sigma_1 + \sigma_2}{2} - \sqrt{\left(\frac{\sigma_1 - \sigma_2}{2}\right)^2 + \tau^2}$$

$$(d) \text{ Maximum shear stress} = \frac{1}{2} \sqrt{(\sigma_1 - \sigma_2)^2 + 4\tau^2}$$

$$(e) \text{ Condition for maximum shear stress, } \tan 2\theta = \frac{\sigma_2 - \sigma_1}{2\tau}$$

9. Mohr's circle of stresses is a graphical method of finding normal, tangential and resultant stresses on an oblique plane.
10. Maximum shear stress by Mohr's circle method, is equal to the radius of the Mohr's circle.
11. The planes of maximum and minimum normal stresses are at an angle of  $90^\circ$  to each other.

### EXERCISE 3

#### (A) Theoretical Questions

1. Define the terms : Principal planes and principal stresses.
2. A rectangular bar is subjected to a direct stress ( $\sigma$ ) in one plane only. Prove that the normal and shear stresses on an oblique plane are given by

$$\sigma_n = \sigma \cos^2 \theta \text{ and } \sigma_t = \frac{\sigma}{2} \sin 2\theta$$

where  $\theta$  = Angle made by oblique plane with the normal cross-section of the bar,

$\sigma_n$  = Normal stress, and

$\sigma_t$  = Tangential or shear stress.

3. A rectangular bar is subjected to two direct stresses ( $\sigma_1$  and  $\sigma_2$ ) in two mutually perpendicular directions. Prove that the normal stress ( $\sigma_n$ ) and shear stress ( $\sigma_t$ ) on an oblique plane which is inclined at an angle  $\theta$  with the axis of minor stress are given by

$$\sigma_n = \frac{\sigma_1 + \sigma_2}{2} + \frac{\sigma_1 - \sigma_2}{2} \cos 2\theta$$

$$\text{and } \sigma_t = \frac{\sigma_1 - \sigma_2}{2} \sin 2\theta.$$

4. Define the term 'obliquity' and how it is determined.

- Derive an expression for the stresses on an oblique plane of a rectangular body, when the body is subjected to a simple shear stress.
- A rectangular body is subjected to direct stresses in two mutually perpendicular directions accompanied by a shear stress. Prove that the normal stress and shear stress on an oblique plane inclined at an angle  $\theta$  with the plane of major direct stress, are given by

$$\sigma_n = \frac{\sigma_1 + \sigma_2}{2} + \frac{\sigma_1 - \sigma_2}{2} \cos 2\theta + \tau \sin 2\theta$$

and

$$\sigma_t = \frac{\sigma_1 - \sigma_2}{2} \sin 2\theta - \tau \cos 2\theta.$$

- Derive an expression for the major and minor principal stresses on an oblique plane, when the body is subjected to direct stresses in two mutually perpendicular directions accompanied by a shear stress.
- Write a note on Mohr's circle of stresses.
- A body is subjected to direct stresses in two mutually perpendicular directions accompanied by a simple shear stress. Draw the Mohr's circle of stresses and explain how will you obtain the principal stresses and principal planes.
- A body is subjected to direct stresses in two mutually perpendicular directions. How will you determine graphically the resultant stress on an oblique plane when :  
(i) the stresses are unequal and unlike, and  
(ii) the stresses are unequal and like.

**(B) Numerical Problems**

- A rectangular bar of cross-sectional area  $12000 \text{ mm}^2$  is subjected to an axial load of  $360 \text{ N/mm}^2$ . Determine the normal and shear stresses on a section which is inclined at an angle of  $30^\circ$  with the normal cross-section of the bar. [Ans.  $9.25 \text{ N/mm}^2$ ,  $1.3 \text{ N/mm}^2$ ]
- Find the diameter of a circular bar which is subjected to an axial pull of  $150 \text{ kN}$ , if the maximum allowable shear stress on any section is  $60 \text{ N/mm}^2$ . [Ans.  $3.989 \text{ cm}$ ]
- A rectangular bar of cross-sectional area  $10000 \text{ mm}^2$  is subjected to a tensile load  $P$  as shown in Fig. 3.32. The permissible normal and shear stresses on the oblique plane  $BC$  are given as  $8 \text{ N/mm}^2$  and  $4 \text{ N/mm}^2$  respectively. Determine the safe value of  $P$ . [Ans.  $92.378 \text{ kN}$ ]

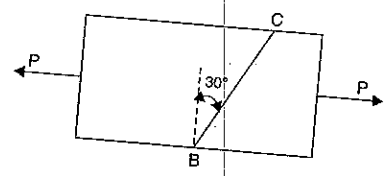

Fig. 3.32

- The principal tensile stress at a point across two mutually perpendicular planes are  $100 \text{ N/mm}^2$  and  $50 \text{ N/mm}^2$ . Determine the normal, tangential and resultant stresses on a plane inclined at  $30^\circ$  to the axis of the minor principal stress. [Ans.  $0.875 \text{ N/mm}^2$ ,  $21.65 \text{ N/mm}^2$ ,  $90.138$ ]
- The principal stresses at a point in a bar are  $160 \text{ N/mm}^2$  (tensile) and  $80 \text{ N/mm}^2$  (compressive). Determine the resultant stress in magnitude and direction on a plane inclined at  $60^\circ$  to the axis of the major principal stress. Also determine the maximum intensity of shear stress in the material [Ans.  $144.22 \text{ N/mm}^2$ ,  $\phi = 46^\circ 5.7$ ,  $120 \text{ N/mm}^2$ ]
- At a point in a strained material, the principal stresses are  $140 \text{ N/mm}^2$  (tensile) and  $60 \text{ N/mm}^2$  (compressive). Determine the resultant stress in magnitude and direction on a plane inclined at  $45^\circ$  to the axis of the major principal stress. What is the maximum intensity of shear stress in the material at the point? [Ans.  $107.7 \text{ N/mm}^2$ ,  $\phi = 61^\circ 11.9$ ,  $100 \text{ N/mm}^2$ ]

- At a point within a body subjected to two mutually perpendicular directions, the stresses are  $100 \text{ N/mm}^2$  (tensile) and  $75 \text{ N/mm}^2$  (tensile). Each of the above stresses, is accompanied by a shear stress of  $75 \text{ N/mm}^2$ . Determine the normal, shear and resultant stresses on an oblique plane inclined at an angle of  $45^\circ$  with the axis of minor tensile stress. [Ans.  $150, 25, 152.07 \text{ N/mm}^2$ ]
- For the problem 7, determine : (i) the direction and magnitude of each of the principal stress and (ii) magnitude of the greatest shear stress. [Ans.  $154.057, -4.057 \text{ N/mm}^2$ ,  $\theta = 35^\circ, 468'$  and  $125^\circ 46.8' \text{ N/mm}^2$ ]
- Direct stresses of  $160 \text{ N/mm}^2$  tensile and  $120 \text{ N/mm}^2$  compressive exist on two perpendicular planes at a certain point in a body. They are also accompanied by shear stresses on the planes. The greatest principal stress at the point due to these is  $200 \text{ N/mm}^2$ .  
(i) What must be the magnitude of the shearing stresses on the two planes?  
(ii) What will be the maximum shearing stress at the point? [Ans. (i)  $113.137 \text{ N/mm}^2$  (ii)  $180 \text{ N/mm}^2$ ]
- At a certain point in a strained material, the stresses on the two planes at right angles to each other are  $40 \text{ N/mm}^2$  and  $20 \text{ N/mm}^2$  both tensile. They are accompanied by a shear stress of magnitude  $20 \text{ N/mm}^2$ . Find graphically or otherwise, the location of principal planes and evaluate the principal stresses. [Ans.  $\theta = 31^\circ 43', 121^\circ 43'$  and  $52.36, 7.64 \text{ N/mm}^2$ ]
- Solve problem 4, by graphical method.
- Solve problem 5, by graphical method.
- Solve problem 4, using Mohr's circle of stresses.
- Solve problem 5, using Mohr's circle of stresses.
- A point in a strained material is subjected to stresses shown in Fig. 3.33. Using Mohr's circle method, determine the normal and tangential stresses across the oblique plane. Check the answer analytically. [Ans.  $105 \text{ N/mm}^2, 15 \text{ N/mm}^2$ ]

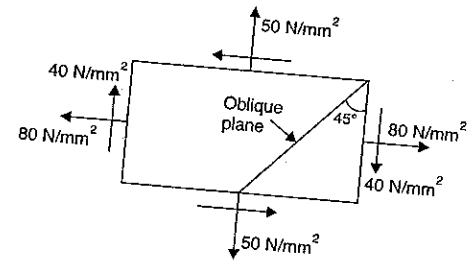

Fig. 3.33

- An elemental cube is subjected to tensile stresses of  $60 \text{ N/mm}^2$  and  $20 \text{ N/mm}^2$  acting on two mutually perpendicular planes and a shear stress of  $20 \text{ N/mm}^2$  on these planes. Draw the Mohr's circle of stresses and hence or otherwise determine the magnitudes and directions of principal stresses and also the greatest shear stress. [Ans.  $68.214, 11.72 \text{ N/mm}^2$ ,  $\theta = 25.5^\circ$  and  $112.5^\circ, 28.28 \text{ N/mm}^2$ ]
- A strained material is subjected to two dimensional stresses. Prove that the sum of the normal components of stresses on any two mutually perpendicular planes is constant. [Hint. Normal stresses on a plane inclined at  $\theta$  with major principal plane is given by

$$\sigma_n = \frac{\sigma_1 + \sigma_2}{2} + \frac{\sigma_1 - \sigma_2}{2} \cos 2\theta$$

...(i)

Normal stress on a plane inclined at  $(\theta + 90^\circ)$  is given by

$$\begin{aligned}\sigma_n^* &= \frac{\sigma_1 + \sigma_2}{2} + \frac{\sigma_1 - \sigma_2}{2} \cos [2(\theta + 90^\circ)] \\ &= \frac{\sigma_1 + \sigma_2}{2} + \frac{\sigma_1 - \sigma_2}{2} \cos (180 + 2\theta) \\ &= \frac{\sigma_1 + \sigma_2}{2} - \frac{\sigma_1 - \sigma_2}{2} \cos 2\theta\end{aligned}\quad \dots(ii)$$

Adding (i) and (ii),  $\sigma_n + \sigma_n^* = \sigma_1 + \sigma_2 = \text{constant}$ .

18. At a point in a two dimensional system, the normal stress on two mutually perpendicular planes are  $\sigma_1$  and  $\sigma_2$  (both alike) and shear stress is  $\tau$ . Show that one of the principal stresses is zero if

$$\tau = \sqrt{\sigma_1 \times \sigma_2}.$$

[Hint. Principal stresses =  $\frac{\sigma_1 + \sigma_2}{2} \pm \sqrt{\left(\frac{\sigma_1 - \sigma_2}{2}\right)^2 + \tau^2}$

$$\begin{aligned}&= \frac{\sigma_1 + \sigma_2}{2} \pm \sqrt{\left(\frac{\sigma_1 - \sigma_2}{2}\right)^2 + \sigma_1 \sigma_2} \\ &= \frac{\sigma_1 + \sigma_2}{2} \pm \sqrt{\left(\frac{\sigma_1 - \sigma_2}{2}\right)^2} = \frac{\sigma_1 + \sigma_2}{2} \pm \frac{\sigma_1 + \sigma_2}{2} \\ &= \sigma_1 + \sigma_2 \text{ and zero.}\end{aligned}$$

19. A rectangular block of material is subjected to a tensile stress of  $100 \text{ N/mm}^2$  on one plane and a tensile stress of  $50 \text{ N/mm}^2$  on a plane at right angles, together with shear stresses of  $60 \text{ N/mm}^2$  on the faces. Find :
- (i) the direction of principal planes, (ii) the magnitude of principal stresses and (iii) magnitude of the greatest shear stress.
- [Ans. (i)  $33^\circ 41'$  or  $123^\circ 41'$  (ii)  $140 \text{ N/mm}^2$  and  $10 \text{ N/mm}^2$  tensiles (iii)  $65 \text{ N/mm}^2$ ]

# 4

## Strain Energy and Impact Loading

### 4.1. INTRODUCTION

Whenever a body is strained, the energy is absorbed in the body. The energy, which is absorbed in the body due to straining effect is known as *strain energy*. The straining effect may be due to gradually applied load or suddenly applied load or load with impact. Hence the strain energy will be stored in the body when the load is applied gradually or suddenly or with an impact. The strain energy stored in the body is equal to the work done by the applied load in stretching the body.

### 4.2. SOME DEFINITIONS

Before deriving the expressions for the strain energy stored in a body due to gradually applied load or suddenly applied load or load with an impact, the following terms will be defined :

1. Resilience
2. Proof resilience, and
3. Modulus of resilience.

**4.2.1. Resilience.** The total strain energy stored in a body is commonly known as resilience. Whenever the straining force is removed from the strained body, the body is capable of doing work. Hence the resilience is also defined as the capacity of a strained body for doing work on the removal of the straining force.

**4.2.2. Proof Resilience.** The maximum strain energy, stored in a body, is known as proof resilience. The strain energy stored in the body will be maximum when the body is stressed upto elastic limit. Hence the proof resilience is the quantity of strain energy stored in a body when strained upto elastic limit.

**4.2.3. Modulus of Resilience.** It is defined as the proof resilience of a material per unit volume. It is an important property of a material. Mathematically,

$$\text{Modulus of resilience} = \frac{\text{Proof resilience}}{\text{Volume of the body}}$$

### 4.3. EXPRESSION FOR STRAIN ENERGY STORED IN A BODY WHEN THE LOAD IS APPLIED GRADUALLY

In Art. 4.1, we have mentioned that the strain energy stored in a body is equal to the work done by the applied load in stretching the body.

Fig. 4.1 shows load extension diagram of a body under tensile test upto elastic limit. The tensile load  $P$  increases gradually from zero to the value of  $P$  and the extension of the body increases from zero to the value of  $x$ .

The load  $P$  performs work in stretching the body. This work will be stored in the body as *strain energy* which is recoverable after the load  $P$  is removed.

Let  $P$  = Gradually applied load,  
 $x$  = Extension of the body,  
 $A$  = Cross-sectional area,  
 $L$  = Length of the body,  
 $V$  = Volume of the body,  
 $E$  = Young's modulus,  
 $U$  = Strain energy stored in the body, and  
 $\sigma$  = Stress induced in the body.

Now work done by the load = Area of load extension curve (Shaded area in Fig. 4.1)

$$\begin{aligned} &= \text{Area of triangle } ONM \\ &= \frac{1}{2} \times P \times x. \end{aligned} \quad \dots(i)$$

But load,  $P = \text{Stress} \times \text{Area} = \sigma \times A$

$$\begin{aligned} \text{and extension, } x &= \text{Strain} \times \text{Length} \quad \left( \because \text{Strain} = \frac{\text{Extension}}{\text{Length}} \therefore \text{Extension} = \text{Strain} \times L \right) \\ &= \frac{\text{Stress}}{E} \times L \quad \left( \because \text{Strain} = \frac{\text{Stress}}{E} \right) \\ &= \frac{\sigma}{E} \times L. \end{aligned} \quad \dots(4.1)$$

Substituting the values of  $P$  and  $x$  in equation (i), we get

$$\begin{aligned} \text{Work done by the load} &= \frac{1}{2} \times \sigma \times A \times \frac{\sigma}{E} \times L = \frac{1}{2} \frac{\sigma^2}{E} \times A \times L \\ &= \frac{\sigma^2}{2E} \times V \quad (\because \text{Volume } V = A \times L) \end{aligned}$$

But the work done by the load in stretching the body is equal to the strain energy stored in the body.

$\therefore$  Energy stored in the body,

$$U = \frac{\sigma^2}{2E} \times V. \quad \dots(4.2)$$

**Proof resilience.** The maximum energy stored in the body without permanent deformation (*i.e.*, upto elastic limit) is known as proof resilience. Hence in equation (4.2), the stress  $\sigma$  is taken at the elastic limit, we will get proof resilience:

$$\therefore \text{Proof resilience} = \frac{\sigma^{*2}}{2E} \times \text{Volume} \quad \dots(4.3)$$

where  $\sigma^*$  = Stress at the elastic limit.

Modulus of resilience = Strain energy per unit volume

$$= \frac{\text{Total strain energy}}{\text{Volume}} = \frac{\frac{\sigma^2}{2E} \times V}{V} = \frac{\sigma^2}{2E} \quad \dots(4.4)$$

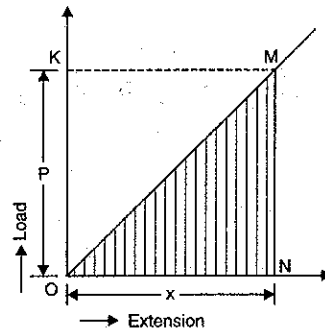

Fig. 4.1

#### 4.4. EXPRESSION FOR STRAIN ENERGY STORED IN A BODY WHEN THE LOAD IS APPLIED SUDDENLY

When the load is applied suddenly to a body, the load is constant throughout the process of the deformation of the body.

Consider a bar subjected to a sudden load.

Let  $P$  = Load applied suddenly,  
 $L$  = Length of the bar,  
 $A$  = Area of the cross-section,  
 $V = \text{Volume of the bar} = A \times L$ ,  
 $E$  = Young's modulus,  
 $x$  = Extension of the bar,  
 $\sigma$  = Stress induced by the suddenly applied load, and  
 $U$  = Strain energy stored.

As the load is applied suddenly, the load  $P$  is constant when the extension of the bar takes place.

$\therefore$  Work done by the load = Load  $\times$  Extension =  $P \times x$ .

The maximum strain energy stored (*i.e.*, energy stored upto elastic limit) in a body is given by

$$\begin{aligned} U &= \frac{\sigma^2}{2E} \times \text{Volume of the body} \\ &= \frac{\sigma^2}{2E} \times A \times L. \quad (\because \text{Volume} = A \times L) \end{aligned}$$

Equating the strain energy stored in the body to the work done, we get

$$\frac{\sigma^2}{2E} \times A \times L = P \times x = P \times \frac{\sigma}{E} \times L. \quad \left[ \because \text{From equation (4.1), } x = \frac{\sigma}{E} \times L \right]$$

Cancelling  $\frac{\sigma \times L}{E}$  to both sides, we get

$$\frac{\sigma \times A}{2} = P \quad \text{or} \quad \sigma = 2 \times \frac{P}{A}. \quad \dots(4.5)$$

From the above equation it is clear that the maximum stress induced due to suddenly applied load is twice the stress induced when the same load is applied gradually.

After obtaining the value of stress ( $\sigma$ ), the values of extension ( $x$ ) and the strain energy stored in the body may be calculated easily.

**Problem 4.1.** A tensile load of 60 kN is gradually applied to a circular bar of 4 cm diameter and 5 m long. If the value of  $E = 2.0 \times 10^5 \text{ N/mm}^2$ , determine :

- stretch in the rod,
- stress in the rod,
- strain energy absorbed by the rod.

**Sol.** Given :

Gradually applied load,

$$P = 60 \text{ kN} = 60 \times 1000 \text{ N}$$

$$\text{Dia. of rod, } d = 4 \text{ cm} = 40 \text{ mm}$$

$$\therefore \text{Area, } A = \frac{\pi}{4} \times 40^2 = 400\pi \text{ mm}^2$$

$$\text{Length of rod, } L = 5 \text{ m} = 500 \text{ cm} = 5000 \text{ mm}$$



$$\therefore \text{Volume of rod, } V = A \times L = 400 \pi \times 5000 = 2 \times 10^6 \pi \text{ mm}^3$$

$$\text{Young's modulus, } E = 2 \times 10^5 \text{ N/mm}^2.$$

Let  $x$  = stretch or extension in the rod,

$\sigma$  = stress in the rod, and

$U$  = strain energy absorbed by the rod.

$$\text{Now stress, } \sigma = \frac{\text{Load}}{\text{Area}} = \frac{P}{A} = \frac{60000}{400\pi} = 47.746 \text{ N/mm}^2. \text{ Ans.}$$

The stretch or extension is given by equation (4.1),

$$x = \frac{\sigma}{E} \times L = \frac{47.746}{2 \times 10^5} \times 5000 = 1.19 \text{ mm. Ans.}$$

The strain energy absorbed by the rod is given by equation (4.2),

$$U = \frac{\sigma^2}{2E} \times V = \frac{47.746^2}{2 \times 2 \times 10^5} \times 2 \times 10^6 \pi = 35810 \text{ N-mm} = 35.81 \text{ N-m. Ans.}$$

**Problem 4.2.** If in problem 4.1, the tensile load of 60 kN is applied suddenly determine:

(i) maximum instantaneous stress induced;

(ii) instantaneous elongation in the rod, and

(iii) strain energy absorbed in the rod.

**Sol. Given :**

The data given in problem 4.1 is  $d = 40$  mm, Area =  $400 \pi \text{ mm}^2$ ,  $L = 5000$  mm, Volume =  $2 \times 10^6 \pi \text{ mm}^3$ ,  $E = 2 \times 10^5 \text{ N/mm}^2$  and suddenly applied load,  $P = 60000$  N.

(i) Maximum instantaneous stress induced

Using equation (4.5),

$$\sigma = 2 \times \frac{P}{A} = 2 \times \frac{60000}{400\pi} = 95.493 \text{ N/mm}^2. \text{ Ans.}$$

(ii) Instantaneous elongation in the rod

Let  $x$  = Instantaneous elongation

$$\text{Then } x = \frac{\sigma}{E} \times L = \frac{95.493}{2 \times 10^5} \times 5000 \quad [\text{see equation (4.1)}]$$

$$= 2.38 \text{ mm. Ans.}$$

(iii) Strain energy is given by,

$$U = \frac{\sigma^2}{2E} \times V = \frac{95.493^2}{2 \times 2 \times 10^5} \times 2 \times 10^6 \pi = 143238 \text{ N-mm}$$

$$= 143.238 \text{ N-m. Ans.}$$

**Problem 4.3.** Calculate instantaneous stress produced in a bar  $10 \text{ cm}^2$  in area and  $3 \text{ m}$  long by the sudden application of a tensile load of unknown magnitude, if the extension of the bar due to suddenly applied load is  $1.5 \text{ mm}$ . Also determine the suddenly applied load. Take  $E = 2 \times 10^5 \text{ N/mm}^2$ .

**Sol. Given :**

$$\text{Area of bar, } A = 10 \text{ cm}^2 = 1000 \text{ mm}^2$$

$$\text{Length of bar, } L = 3 \text{ m} = 3000 \text{ mm}$$

Extension due to suddenly applied load,

$$x = 1.5 \text{ mm}$$

$$\text{Young's modulus, } E = 2 \times 10^5 \text{ N/mm}^2.$$

Let  $\sigma$  = Instantaneous stress due to sudden load, and

$P$  = Suddenly applied load.

The extension  $x$  is given by equation (4.1),

$$x = \frac{\sigma}{E} \times L \text{ or } 1.5 = \frac{\sigma}{2 \times 10^5} \times 3000$$

$$\therefore \sigma = \frac{1.5 \times 2 \times 10^5}{3000} = 100 \text{ N/mm}^2. \text{ Ans.}$$

**Suddenly applied load**

The instantaneous stress produced by a sudden load is given by equation (4.5) as

$$\sigma = 2 \times \frac{P}{A} \text{ or } 100 = 2 \times \frac{P}{1000}$$

$$\therefore P = \frac{1000 \times 100}{2} = 50000 \text{ N} = 50 \text{ kN. Ans.}$$

**Problem 4.4.** A steel rod is  $2 \text{ m}$  long and  $50 \text{ mm}$  in diameter. An axial pull of  $100 \text{ kN}$  is suddenly applied to the rod. Calculate the instantaneous stress induced and also the instantaneous elongation produced in the rod. Take  $E = 200 \text{ GN/m}^2$ .

**Sol. Given :**

$$\text{Length, } L = 2 \text{ m} = 2 \times 1000 = 2000 \text{ mm}$$

$$\text{Diameter, } d = 50 \text{ mm}$$

$$\therefore \text{Area, } A = \frac{\pi}{4} \times 50^2 = 625 \pi \text{ mm}^2$$

Suddenly applied load,

$$P = 100 \text{ kN} = 100 \times 1000 \text{ N}$$

$$\text{Value of } E = 200 \text{ GN/m}^2 = 200 \times 10^9 \text{ N/m}^2 \quad (\because G = \text{Giga} = 10^9)$$

$$= \frac{200 \times 10^9}{10^6} \text{ N/mm}^2 \quad (\because 1 \text{ m} = 1000 \text{ mm} \therefore \text{m}^2 = 10^6 \text{ mm}^2)$$

$$= 200 \times 10^3 \text{ N/mm}^2$$

Using equation (4.5) for suddenly applied load,

$$\sigma = 2 \times \frac{P}{A} = 2 \times \frac{100 \times 1000}{625 \pi} \text{ N/mm}^2 = 101.86 \text{ N/mm}^2. \text{ Ans.}$$

Let  $dL$  = Elongation

$$\text{Then } dL = \frac{P}{E} \times L = \frac{101.86}{200 \times 10^3} \times 2000 = 1.0186 \text{ mm. Ans.}$$

**Problem 4.5.** A uniform metal bar has a cross-sectional area of  $700 \text{ mm}^2$  and a length of  $1.5 \text{ m}$ . If the stress at the elastic limit is  $160 \text{ N/mm}^2$ , what will be its proof resilience? Determine also the maximum value of an applied load, which may be suddenly applied without exceeding the elastic limit. Calculate the value of the gradually applied load which will produce the same extension as that produced by the suddenly applied load above.

Take  $E = 2 \times 10^5 \text{ N/mm}^2$ .

**Sol. Given :**

$$\text{Area, } A = 700 \text{ mm}^2$$

$$\text{Length, } L = 1.5 \text{ m} = 1500 \text{ mm}$$

$$\therefore \text{Volume of bar, } V = A \times L = 700 \times 1500 = 1050000 \text{ mm}^3$$

Stress at elastic limit,  $\sigma^* = 160 \text{ N/mm}^2$

Young's modulus,  $E = 2 \times 10^5 \text{ N/mm}^2$

(i) Proof resilience is given by equation (4.3), as

$$\begin{aligned} \text{Proof resilience} &= \frac{\sigma^{*2}}{2E} \times \text{Volume} = \frac{160^2}{2 \times 2 \times 10^5} \times 1050000 \\ &= 67200 \text{ N-mm} = \mathbf{67.2 \text{ N-m. Ans.}} \end{aligned}$$

(ii) Let  $P$  = Maximum value of suddenly applied load, and  
 $P_1$  = Gradually applied load.

Using equation (4.5) for suddenly applied load,

$$\sigma^* = 2 \times \frac{P}{A} \quad (\text{change } p \text{ to } p^*)$$

$$\therefore P = \frac{\sigma^* \times A}{2} = \frac{160 \times 700}{2} = 56000 \text{ N} = \mathbf{56 \text{ kN. Ans.}}$$

For gradually applied load,

$$\sigma^* = \frac{P_1}{A}$$

$$\text{or } P_1 = \sigma^* \times A = 160 \times 700 = 112000 \text{ N} = \mathbf{112 \text{ kN. Ans.}}$$

**Problem 4.6.** A tension bar 5 m long is made up of two parts, 3 metre of its length has a cross-sectional area of  $10 \text{ cm}^2$  while the remaining 2 metre has a cross-sectional area of  $20 \text{ cm}^2$ . An axial load of 80 kN is gradually applied. Find the total strain energy produced in the bar and compare this value with that obtained in a uniform bar of the same length and having the same volume when under the same load. Take  $E = 2 \times 10^5 \text{ N/mm}^2$ .

**Sol.** Given :

Total length of bar,  $L = 5 \text{ m} = 5000 \text{ mm}$

Length of 1st part,  $L_1 = 3 \text{ m} = 3000 \text{ mm}$

Area of 1st part,  $A_1 = 10 \text{ cm}^2 = 10 \times 100 \text{ mm}^2 = 1000 \text{ mm}^2$

$\therefore$  Volume of 1st part,

$$V_1 = A_1 \times L_1 = 1000 \times 3000 = 3 \times 10^6 \text{ mm}^3$$

Length of 2nd part,  $L_2 = 2 \text{ m} = 2000 \text{ mm}$

Area of 2nd part,  $A_2 = 20 \text{ cm}^2 = 20 \times 100 \text{ mm}^2 = 2000 \text{ mm}^2$

$\therefore$  Volume of 2nd part,  $V_2 = 2000 \times 2000 = 4 \times 10^6 \text{ mm}^3$

Axial gradual load,  $P = 80 \text{ kN} = 80 \times 1000 = 80000 \text{ N}$

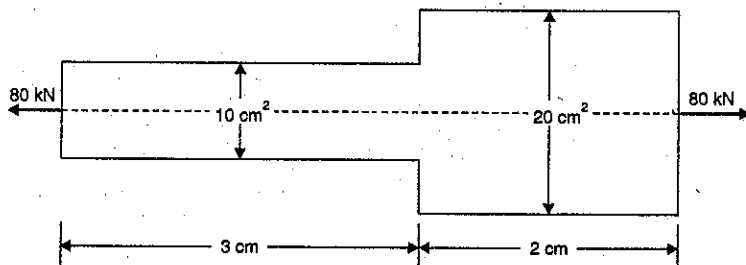

Fig. 4.2

Young's modulus  $E = 2 \times 10^5 \text{ N/mm}^2$

Stress in 1st part  $\sigma_1 = \frac{\text{Load}}{A_1} = \frac{80000}{1000} = 80 \text{ N/mm}^2$

Stress in 2nd part  $\sigma_2 = \frac{P}{A_2} = \frac{80000}{2000} = 40 \text{ N/mm}^2$

Strain energy in 1st part,

$$U_1 = \frac{\sigma_1^2}{2E} \times V_1 = \frac{80^2}{2 \times 2 \times 10^5} \times 3 \times 10^6 = 48000 \text{ N-mm} = 48 \text{ N-m}$$

Strain energy in 2nd part,

$$U_2 = \frac{\sigma_2^2}{2E} \times V_2 = \frac{40^2}{2 \times 2 \times 10^5} \times 4000000 = 16000 \text{ N-mm} = 16 \text{ N-m}$$

$\therefore$  Total strain energy produced in the bar,

$$U = U_1 + U_2 = 48 + 16 = \mathbf{64 \text{ N-m. Ans.}}$$

**Strain energy stored in a uniform bar**

Volume of uniform bar,  $V = V_1 + V_2 = 3000000 + 4000000 = 7000000 \text{ mm}^3$

Length of uniform bar,  $L = 5 \text{ m} = 5000 \text{ mm}$

Let  $A$  = Area of uniform bar

Then  $V = A \times L$  or  $7000000 = A \times 5000$

$$\therefore A = \frac{7000000}{5000} = 1400 \text{ mm}^2$$

Stress in uniform bar,  $\sigma = \frac{P}{A} = \frac{80000}{1400} = 57.143 \text{ N/mm}^2$

$\therefore$  Strain energy stored in the uniform bar,

$$\begin{aligned} U &= \frac{\sigma^2}{2E} \times V = \frac{57.143^2}{2 \times 2 \times 10^5} \times 7000000 \\ &= 57143 \text{ N-mm} = 57.143 \text{ N-m} \end{aligned}$$

$$\therefore \frac{\text{Strain energy in the given bar}}{\text{Strain energy in the uniform bar}} = \frac{64}{57.143} = \mathbf{1.12. Ans.}$$

**Problem 4.7.** A bar of uniform cross-section 'A' and length 'L' hangs vertically, subjected to its own weight. Prove that the strain energy stored within the bar is given by

$$U = \frac{A \times \rho^2 \times L^3}{6E}$$

where  $E$  = Modulus of Elasticity,

$\rho$  = Weight per unit volume of the bar.

(AMIE, Summer 1989)

**Sol.** Given :

$A$  = Cross-sectional area,

$L$  = Length of bar,

$E$  = Modulus of Elasticity,

$\rho$  = Weight per unit volume.

Consider an element at a distance 'x' from the lower end of the bar as shown in Fig. 4.2 (a). Let 'dx' be the thickness of the element.

The section  $x-x$  will be acted upon by the weight of the bar of length  $x$ .

$$\begin{aligned} \text{Let } W_x &= \text{Weight of the bar of length } x \\ &= (\text{Volume of the bar of length } x) \\ &\quad \times \text{Weight of unit Volume} \\ &= (A \times x) \times \rho = \rho Ax \end{aligned}$$

As a result of this weight, the portion  $dx$  will experience a small elongation  $d\delta$ . Then

$$\begin{aligned} \text{Strain in portion } dx &= \frac{\text{Elongation in } dx}{\text{Length of } dx} \\ &= \frac{d\delta}{dx} \end{aligned}$$

$$\begin{aligned} \text{Stress in portion } dx &= \frac{\text{Weight acting on section } x-x}{\text{Area of section}} \\ &= \frac{\rho \times A \times x}{A} = \rho \times x \end{aligned}$$

$$\begin{aligned} \text{Also } E &= \frac{\text{Stress}}{\text{Strain}} \\ &= \frac{\rho \times x}{\left(\frac{d\delta}{dx}\right)} = \frac{\rho \times x \times dx}{d\delta} \end{aligned}$$

$$\therefore d\delta = \frac{\rho \times x \times dx}{E}$$

Now the strain energy stored in portion  $dx$  is given by,  
 $dU = \text{Average Weight} \times \text{Elongation of } dx$

$$\begin{aligned} &= \left(\frac{1}{2} \times Wx\right) \times d\delta \\ &= \left(\frac{1}{2} \times \rho Ax\right) \times \frac{\rho \times x \times dx}{E} \quad (\because Wx = \rho Ax) \\ &= \frac{1}{2} \times \rho^2 Ax^2 \times \frac{dx}{E} \end{aligned}$$

Total strain energy stored within the bar due to its own weight  $W$  is obtained by integrating the above equation from 0 to  $L$ .

$$\begin{aligned} \therefore U &= \int_0^L dU \\ &= \int_0^L \frac{1}{2} \times \rho^2 Ax^2 \times \frac{dx}{E} \\ &= \frac{1}{2} \times \frac{\rho^2 \times A}{E} \int_0^L x^2 dx \end{aligned}$$

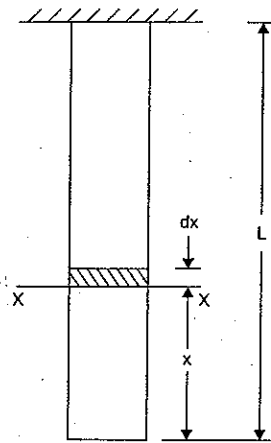

Fig. 4.2 (a)

$$\begin{aligned} &= \frac{1}{2} \times \frac{\rho^2 \times A}{E} \times \left[ \frac{x^3}{3} \right]_0^L \\ &= \frac{1}{2} \times \frac{\rho^2 \times A}{E} \times \frac{L^3}{3} \\ &= \frac{A \times \rho^2 \times L^3}{6E} \quad \text{Ans.} \end{aligned}$$

**Problem 4.8.** The maximum stress produced by a pull in a bar of length 1 m is  $150 \text{ N/mm}^2$ . The area of cross-sections and length are shown in Fig. 4.3. Calculate the strain energy stored in the bar if  $E = 2 \times 10^5 \text{ N/mm}^2$ .

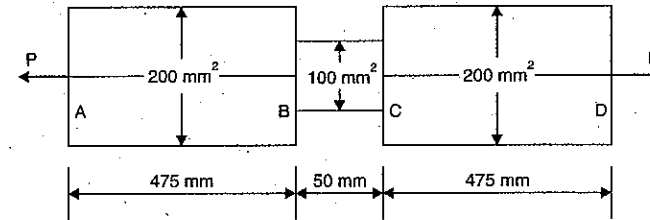

Fig. 4.3

**Sol. Given :**

Length of bar,	$L = 1 \text{ m} = 1000 \text{ mm}$
Max. stress,	$\sigma = 150 \text{ N/mm}^2$
Part AB : Length,	$L_1 = 475 \text{ mm}$
Area,	$A_1 = 200 \text{ mm}^2$
Part BC : Length,	$L_2 = 50 \text{ mm}$
Area,	$A_2 = 100 \text{ mm}^2$
Part CD : Length,	$L_3 = 475 \text{ mm}$
Area,	$A_3 = 200 \text{ mm}^2$
Value of	$E = 2 \times 10^5 \text{ N/mm}^2$

In this problem, maximum stress is given. Axial pull  $P$  is not known. But stress in equal to load/area. As load (or axial pull) for the bar is same, hence stress will be maximum, when area will be minimum. Part BC is having less area and hence stress in part BC will be maximum. As parts AB and CD are having same areas, hence stresses in them will be equal.

$$\begin{aligned} \text{Let } \sigma_2 &= \text{Stress in part BC} = 150 \text{ N/mm}^2 \\ \sigma_1 &= \text{Stress in part AB or in part CD} \end{aligned}$$

$$\text{Now load} = \text{Stress} \times \text{Area}$$

$$\text{or load} = \sigma_1 \times A_1 = \sigma_2 A_2$$

$$\therefore \sigma_1 = \frac{\sigma_2 A_2}{A_1} = \frac{150 \times 100}{200} = 75 \text{ N/mm}^2$$

Now strain energy stored in part AB,

$$U_1 = \frac{\sigma_1^2}{2E} \times V_1 \quad \dots(i)$$

where

$$\begin{aligned} V_1 &= \text{Volume of part AB} \\ &= A_1 \times L_1 = 200 \times 475 \\ &= 95000 \text{ mm}^3 \end{aligned}$$

Substituting this value in equation (i), we get

$$\begin{aligned} U_1 &= \frac{\sigma_1^2}{2E} \times 95000 \\ &= \frac{75^2}{2 \times 2 \times 10^5} \times 95000 \\ &= 1335.938 \text{ N-mm} \end{aligned}$$

Strain energy stored in part BC,

$$\begin{aligned} U_2 &= \frac{\sigma_2^2}{2E} \times V_2 \\ &= \frac{150^2}{2 \times 2 \times 10^5} \times A_2 \times L_2 \quad (\because V_2 = A_2 \times L_2) \\ &= \frac{150^2}{2 \times 2 \times 10^5} \times 100 \times 50 = 281.25 \text{ N-mm} \end{aligned}$$

Energy stored in part CD,

$$U_3 = \frac{\sigma_3^2}{2E} \times V_3 = 1335.938 \text{ N-mm} \quad (\because V_3 = V_1, \sigma_3 = \sigma_1 \therefore U_3 = U_1)$$

\(\therefore\) Total strain energy stored,

$$\begin{aligned} U &= U_1 + U_2 + U_3 = 1335.938 + 281.25 + 1335.938 \text{ N-mm} \\ &= 2953.126 \text{ N-mm. Ans.} \end{aligned}$$

#### 4.5. EXPRESSION FOR STRAIN ENERGY STORED IN A BODY WHEN THE LOAD IS APPLIED WITH IMPACT

The load dropped from a certain height before the load commences to stretch the bar is a case of a load applied with impact. Consider a vertical rod fixed at the upper end and having a collar at the lower end as shown in Fig. 4.4. Let the load be dropped from a height on the collar. Due to this impact load, there will be some extension in the rod.

Let  $P$  = Load dropped (i.e., load applied with impact)

$L$  = Length of the rod,

$A$  = Cross-sectional area of the rod,

$V$  = Volume of rod =  $A \times L$ ,

$h$  = Height through which load is dropped,

$\delta L$  = Extension of the rod due to load  $P$ ,

$E$  = Modulus of elasticity of the material of rod,

$\sigma$  = Stress induced in the rod due to impact load.

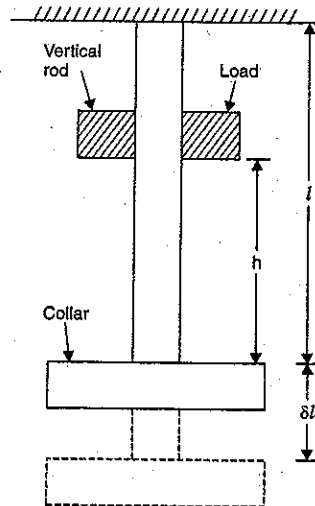

Fig. 4.4

The strain in the bar is given by,

$$\text{Strain} = \frac{\text{Stress}}{E}$$

i.e.,

$$\frac{\delta L}{L} = \frac{\sigma}{E}$$

$$\delta L = \frac{\sigma}{E} \times L \quad \dots(4.6)$$

Work done by the load = Load  $\times$  Distance moved

$$= P(h + \delta L) \quad \dots(i)$$

The strain energy stored by the rod,

$$U = \frac{\sigma^2}{2E} \times V = \frac{\sigma^2}{2E} \times AL \quad \dots(ii)$$

Equating the work done by the load to the strain energy stored, we get

$$P(h + \delta L) = \frac{\sigma^2}{2E} \cdot AL$$

or

$$P \left( h + \frac{\sigma}{E} \cdot L \right) = \frac{\sigma^2}{2E} \cdot AL \quad \left( \because \delta L = \frac{\sigma}{E} \cdot L \right)$$

or

$$Ph + P \cdot \frac{\sigma}{E} \cdot L = \frac{\sigma^2}{2E} \cdot AL$$

or

$$\frac{\sigma^2}{2E} \cdot AL - P \cdot \frac{\sigma}{E} \cdot L - Ph = 0$$

Multiplying by  $\frac{2E}{AL}$  to both sides, we get

$$\sigma^2 - P \cdot \frac{\sigma}{E} \cdot L \times \frac{2E}{A \cdot L} - Ph \cdot \frac{2E}{AL} = 0$$

or

$$\sigma^2 - \frac{2P}{A} \cdot \sigma - \frac{2PEh}{A \cdot L} = 0.$$

The above equation is a quadratic equation in ' $\sigma$ ',

$$\therefore \sigma = \frac{\frac{2P}{A} \pm \sqrt{\left(\frac{2P}{A}\right)^2 + 4 \cdot \frac{2PEh}{A \cdot L}}}{2 \times 1} \quad \left( \because \text{roots} = \frac{b^2 \pm \sqrt{4ac}}{2a} \right)$$

$$= \frac{P}{A} \pm \sqrt{\frac{4P^2}{4A^2} + \frac{8 \cdot PEh}{4 \cdot A \cdot L}} = \frac{P}{A} \pm \sqrt{\left(\frac{P}{A}\right)^2 + \frac{2PEh}{A \cdot L}}$$

$$= \frac{P}{A} + \sqrt{\left(\frac{P}{A}\right)^2 + \frac{2PEh}{A \cdot L}} \quad (\text{Neglecting - ve root})$$

$$= \frac{P}{A} + \frac{P}{A} \sqrt{1 + \frac{2PEh}{A \cdot L} \times \frac{A^2}{P^2}} = \frac{P}{A} + \frac{P}{A} \sqrt{1 + \frac{2AEh}{P \cdot L}}$$

$$= \frac{P}{A} \left( 1 + \sqrt{1 + \frac{2AEh}{P \cdot L}} \right) \quad \dots(4.7)$$

After knowing the value of ' $\sigma$ ', the strain energy can be obtained.

**Important Conclusions**

(i) If  $\delta L$  is very small in comparison with  $h$ .

The work done by load =  $P \cdot h$

Equating the work done by the load to the strain energy stored in the rod, we get

$$P \cdot h = \frac{\sigma^2}{2E} \cdot AL$$

$$\therefore \sigma^2 = \frac{2E \cdot P \cdot h}{A \cdot L} \quad \text{and} \quad \sigma = \sqrt{\frac{2EPh}{A \cdot L}} \quad \dots(4.8)$$

(ii) In equation (4.7), if  $h = 0$ , we get

$$\sigma = \frac{P}{A} (1 + \sqrt{1+0}) = \frac{P}{A} (1+1) = \frac{2P}{A}$$

which is the case of suddenly applied load.

Once the stress  $p$  is known, the corresponding instantaneous extension ( $\delta L$ ) and the strain energy ( $U$ ) can be obtained.

**Problem 4.9.** A weight of 10 kN falls by 30 mm on a collar rigidly attached to a vertical bar 4 m long and 1000 mm<sup>2</sup> in section. Find the instantaneous expansion of the bar. Take  $E = 210$  GPa. Derive the formula you use. (Bhavnagar University, Feb. 1992)

**Sol. Given :**

Falling weight,  $P = 10 \text{ kN} = 10,000 \text{ N}$

Falling height,  $h = 30 \text{ mm}$

Length of bar,  $L = 4 \text{ m} = 4000 \text{ mm}$

Area of bar,  $A = 1000 \text{ mm}^2$

Value of  $E = 210 \text{ GPa} = 210 \times 10^9 \text{ N/m}^2$

( $\because$  G = Giga =  $10^9$  and Pa = Pascal =  $1 \text{ N/m}^2$ )

$$= \frac{210 \times 10^9 \text{ N}}{10^6 \text{ mm}^2} \quad (\because 1 \text{ m} = 1000 \text{ mm} \text{ and } \text{m}^2 = 10^6 \text{ mm}^2)$$

$$= 210 \times 10^3 \text{ N/mm}^2 = 2.1 \times 10^5 \text{ N/mm}^2$$

Let  $dL =$  Instantaneous elongation due to falling weight

$\sigma =$  Instantaneous stress produced due to falling weight

Using equation (4.7), we get

$$\sigma = \frac{P}{A} \left( 1 + \sqrt{1 + \frac{2EAh}{P \times L}} \right)$$

$$= \frac{10000}{1000} \left( 1 + \sqrt{1 + \frac{2 \times 2.1 \times 10^5 \times 1000 \times 30}{10000 \times 4000}} \right)$$

$$= 10 (1 + \sqrt{1 + 315}) = 10 (1 + \sqrt{316})$$

$$= 10 \times 18.77 = 187.7 \text{ N/mm}^2$$

Now

$$E = \frac{\text{Stress}}{\text{Strain}} = \frac{\sigma}{\left(\frac{\delta L}{L}\right)} \quad \text{or} \quad \frac{\delta L}{L} = \frac{\sigma}{E}$$

$$\therefore \delta L = \frac{\sigma}{E} \times L = \frac{187.7 \times 4000}{2.1 \times 10^5} = 3.575 \text{ mm. Ans.}$$

**Problem 4.10.** A load of 100 N falls through a height of 2 cm on to a collar rigidly attached to the lower end of a vertical bar 1.5 m long and of 1.5 cm<sup>2</sup> cross-sectional area. The upper end of the vertical bar is fixed.

Determine :

(i) maximum instantaneous stress induced in the vertical bar,

(ii) maximum instantaneous elongation, and

(iii) strain energy stored in the vertical rod.

Take  $E = 2 \times 10^5 \text{ N/mm}^2$ .

**Sol. Given :**

Impact load,  $P = 100 \text{ N}$

Height through which load falls,

$$h = 2 \text{ cm} = 20 \text{ mm}$$

Length of bar,  $L = 1.5 \text{ m} = 1500 \text{ mm}$

Area of bar,  $A = 1.5 \text{ cm}^2 = 1.5 \times 100 \text{ mm}^2 = 150 \text{ mm}^2$

$\therefore$  Volume,  $V = A \times L = 150 \times 1500 = 225000 \text{ mm}^3$

Modulus of elasticity,  $E = 2 \times 10^5 \text{ N/mm}^2$

Let  $\sigma =$  Maximum instantaneous stress induced in the vertical bar,

$\delta L =$  Maximum elongation, and

$U =$  Strain energy stored.

(i) Using equation (4.7),

$$\sigma = \frac{P}{A} \left( 1 + \sqrt{1 + \frac{2AEh}{P \cdot L}} \right) = \frac{100}{150} \left( 1 + \sqrt{1 + \frac{2 \times 150 \times 2 \times 10^5 \times 20}{100 \times 1500}} \right)$$

$$= \frac{100}{150} (1 + \sqrt{1 + 8000}) = 60.23 \text{ N/mm}^2. \text{ Ans.}$$

(ii) Using equation (4.6),

$$\delta L = \frac{\sigma}{E} \times L = \frac{60.23 \times 1500}{2 \times 10^5} = 0.452 \text{ mm. Ans.}$$

(iii) Strain energy is given by,

$$U = \frac{\sigma^2}{2E} \times V = \frac{60.23^2}{2 \times 2 \times 10^5} \times 225000 = 2045 \text{ N-mm}$$

$$= 2.045 \text{ N-m. Ans.}$$

**Problem 4.11.** The maximum instantaneous extension, produced by an unknown falling weight through a height of 4 cm in a vertical bar of length 3 m and of cross-sectional area 5 cm<sup>2</sup>, is 2.1 mm.

Determine :

(i) the instantaneous stress induced in the vertical bar, and

(ii) the value of unknown weight. Take  $E = 2 \times 10^5 \text{ N/mm}^2$ .

**Sol. Given :**

Instantaneous extension,  $\delta L = 2.1 \text{ mm}$

Length of bar,  $L = 3 \text{ m} = 3000 \text{ mm}$

Area of bar,  $A = 5 \text{ cm}^2 = 500 \text{ mm}^2$

$\therefore$  Volume of bar,  $V = 500 \times 3000 = 1500000 \text{ mm}^3$

Height through which weight falls,  $h = 4 \text{ cm} = 40 \text{ mm}$

Modulus of elasticity,  $E = 2 \times 10^5 \text{ N/mm}^2$

Let  $\sigma =$  Instantaneous stress produced, and  
 $P =$  Unknown weight.

We know  $E = \frac{\text{Stress}}{\text{Strain}}$  or  $\text{Stress} = E \times \text{Strain}$

$\therefore$  Instantaneous stress  $= E \times$  Instantaneous strain  $= E \times \frac{\delta L}{L}$

$$= 2 \times 10^5 \times \frac{2.1}{3000} \text{ N/mm}^2 = 140 \text{ N/mm}^2. \text{ Ans.}$$

Equating the work done by the falling weight to the strain energy stored, we get

$$P(h + \delta L) = \frac{\sigma^2}{2E} \times V$$

$$P(40 + 2.1) = \frac{140^2}{2 \times 2 \times 10^5} \times 1500000 = 73500$$

$$P = \frac{73500}{42.1} = 1745.8 \text{ N. Ans.}$$

**Note.** The value of  $P$  can also be obtained by using equation (4.7).

**Problem 4.12.** An unknown weight falls through a height of 10 mm on a collar rigidly attached to the lower end of a vertical bar 500 cm long and 600 mm<sup>2</sup> in section. If the maximum extension of the rod is to be 2 mm, what is the corresponding stress and magnitude of the unknown weight? Take  $E = 2.0 \times 10^5 \text{ N/mm}^2$ . (AMIE, Winter 1984)

**Sol. Given :**

Height through which the weight falls,  $h = 10 \text{ mm}$

Length of the bar,  $L = 500 \text{ cm} = 5000 \text{ mm}$

Area of the bar,  $A = 600 \text{ mm}^2$

Maximum extension,  $\delta L = 2 \text{ mm}$

Young's modulus,  $E = 2.0 \times 10^5 \text{ N/mm}^2$

Let  $\sigma =$  Instantaneous stress produced in the bar, and  
 $P =$  Weight falling on the collar.

We know  $E = \frac{\text{Stress}}{\text{Strain}}$

$\therefore$   $\text{Stress} = E \times \text{Strain} = E \times \frac{\delta L}{L}$  ( $\therefore \text{Strain} = \frac{\delta L}{L}$ )

Substituting the known values, we get

$$\sigma = 2.0 \times 10^5 \times \frac{2}{5000} = 80 \text{ N/mm}^2. \text{ Ans.}$$

**Value of weight falling on the collar**

Using equation (4.7),

$$\sigma = \frac{P}{A} \left( 1 + \sqrt{1 + \frac{2A \cdot E \cdot h}{P \cdot L}} \right)$$

$$\text{or } 80 = \frac{P}{600} \left( 1 + \sqrt{1 + \frac{2 \times 600 \times 2.0 \times 10^5 \times 10}{P \times 5000}} \right)$$

$$\text{or } \frac{48000}{P} = 1 + \sqrt{1 + \frac{480000}{P}}$$

$$\text{or } \frac{48000}{P} - 1 = \sqrt{1 + \frac{480000}{P}}$$

Squaring both sides,

$$\left( \frac{48000}{P} \right)^2 + 1 - \frac{2 \times 48000}{P} = 1 + \frac{480000}{P}$$

$$\text{or } \frac{2304000000}{P^2} - \frac{96000}{P} = \frac{480000}{P} \text{ (cancelling 1 to both sides)}$$

$$\text{or } \frac{2304000000}{P^2} = \frac{480000}{P} + \frac{96000}{P} = \frac{576000}{P}$$

$$\text{or } \frac{2304000000}{P} = 576000 \text{ (cancelling } \frac{1}{P} \text{ to both sides)}$$

$$\text{or } P = \frac{2304000000}{576000} = 4000 \text{ N} = 4 \text{ kN. Ans.}$$

**Problem 4.13.** A bar 12 mm diameter gets stretched by 3 mm under a steady load of 8000 N. What stress would be produced in the same bar by a weight of 800 N, which falls vertically through a distance of 8 cm on to a rigid collar attached at its end? The bar is initially unstressed. Take  $E = 2.0 \times 10^5 \text{ N/mm}^2$ . (AMIE, Winter 1986)

**Sol. Given :**

Dia. of bar,  $d = 12 \text{ mm}$

$\therefore$  Area of bar,  $A = \frac{\pi}{4} (12)^2 = 113.1 \text{ mm}^2$

Increase in length,  $\delta L = 3 \text{ mm}$

Steady load,  $W = 8000 \text{ N}$

Falling weight,  $P = 800 \text{ N}$

Vertical distance,  $h = 8 \text{ cm} = 80 \text{ mm}$

Young's modulus,  $E = 2.0 \times 10^5 \text{ N/mm}^2$

Let  $L =$  Length of the bar, and

$\sigma =$  Stress produced by the falling weight.

**With steady load**

We know  $E = \frac{\text{Stress}}{\text{Strain}} = \frac{\text{(Steady load)}}{\frac{\text{Area}}{\frac{\delta L}{L}}}$

$$\text{or } 2.0 \times 10^5 = \frac{\left( \frac{8000}{113.1} \right)}{\left( \frac{3}{L} \right)} = \frac{8000}{113.1} \times \frac{L}{3}$$

$$L = \frac{2.0 \times 10^5 \times 1131 \times 3}{8000} = 8482.5 \text{ mm}$$

Now using equation (4.7), we get

$$\begin{aligned} \sigma &= \frac{P}{A} \left( 1 + \sqrt{1 + \frac{2AEh}{PL}} \right) \\ &= \frac{800}{1131} \left( 1 + \sqrt{1 + \frac{2 \times 1131 \times 2.0 \times 10^5 \times 80}{8.0 \times 8482.5}} \right) \text{ N/mm}^2 \\ &= 7.0734(1 + \sqrt{1 + 533.33}) = 7.0734 \times 24.1155 \\ &= 170.578 \text{ N/mm}^2. \text{ Ans.} \end{aligned}$$

**Problem 4.14.** A rod 12.5 mm in diameter is stretched 3.2 mm under a steady load of 10 kN. What stress would be produced in the bar by a weight of 700 N, falling through 75 mm before commencing to stretch, the rod being initially unstressed? The value of  $E$  may be taken as  $2.1 \times 10^5 \text{ N/mm}^2$ . (AMIE, Winter 1988)

**Sol. Given :**

Dia. of rod,  $d = 12.5 \text{ mm}$

$\therefore$  Area of rod,  $A = \frac{\pi}{4} \times 12.5^2 = 122.72 \text{ mm}^2$

Increase in length,  $\delta L = 3.2 \text{ mm}$

Steady load,  $W = 10 \text{ kN} = 10,000 \text{ N}$

Falling load,  $P = 700 \text{ N}$

Falling height,  $h = 75 \text{ mm}$

Young's modulus,  $E = 2.1 \times 10^5 \text{ N/mm}^2$

Let  $L =$  Length of the rod,

$\sigma =$  Stress produced by the falling weight.

We know  $E = \frac{\text{Stress}}{\text{Strain}}$

$$= \frac{\left( \frac{\text{Steady load}}{\text{Area}} \right)}{\left( \frac{\delta L}{L} \right)}$$

$$2.1 \times 10^5 = \frac{\left( \frac{10,000}{122.72} \right)}{\left( \frac{3.2}{L} \right)}$$

$$= \left( \frac{10,000}{122.72} \right) \times \left( \frac{L}{3.2} \right)$$

or

$$L = \frac{2.1 \times 10^5 \times 122.72 \times 3.2}{10,000} = 8246.7 \text{ mm}$$

Now using equation (4.7), we get

$$\begin{aligned} \sigma &= \frac{P}{A} \left( 1 + \sqrt{1 + \frac{2AEh}{P \times L}} \right) \\ &= \frac{700}{122.72} \left( 1 + \sqrt{1 + \frac{2 \times 122.72 \times 2.1 \times 10^5 \times 75}{700 \times 8246.7}} \right) \\ &= 153.74 \text{ N/mm}^2. \text{ Ans.} \end{aligned}$$

**Problem 4.15.** A vertical round steel rod 1.82 metre long is securely held at its upper end. A weight can slide freely on the rod and its fall is arrested by a stop provided at the lower end of the rod. When the weight falls from a height of 30 mm above the stop the maximum stress reached in the rod is estimated to be  $157 \text{ N/mm}^2$ . Determine the stress in the rod if the load had been applied gradually and also the minimum stress if the load had fallen from a height of 47.5 mm.

Take  $E = 2.1 \times 10^5 \text{ N/mm}^2$ .

**Sol. Given :**

Length of rod,  $L = 1.82 \text{ m} = 1.82 \times 1000 = 1820 \text{ mm}$

Height through which load falls,  $h = 30 \text{ mm}$

Maximum stress induced in the rod,  $\sigma = 157 \text{ N/mm}^2$

Modulus of elasticity,  $E = 2.1 \times 10^5 \text{ N/mm}^2$

Let  $\sigma_1 =$  Stress induced in the rod if the load is applied gradually and  
 $\sigma_2 =$  Maximum stress if the load had fallen from a height of 47.5 mm.

Strain energy stored in the rod when load falls through a height of 30 mm,

$$\begin{aligned} U &= \frac{\sigma^2}{2E} \times \text{Volume} = \frac{157}{2 \times 2.1 \times 10^5} \times V \\ &= 0.05868 \times V \text{ N-m} \end{aligned}$$

The extension of the rod is given by equation (4.6),

$$\begin{aligned} \delta L &= \frac{\sigma}{E} \times L \\ &= \frac{157}{2.1 \times 10^5} \times 1820 = 1.36 \text{ mm} \end{aligned}$$

$\therefore$  Total distance through which load falls

$$= h + \delta L = 30 + 1.36 = 31.36 \text{ mm}$$

$\therefore$  Work done by the falling load = Load  $\times$  Total distance

$$= P \times 31.36$$

Equating the work done by the falling load to the strain energy stored, we get

$$P \times 31.36 = 0.05868 \times V$$

$$\text{or } \frac{P}{V} = \frac{0.05868}{31.36} = 0.001871$$

$$\text{or } \frac{P}{A.L} = 0.001871 \quad (\because V = A.L)$$

$$\text{or } \frac{P}{A} = 0.001871 \times L = 0.001871 \times 1820 = 3.4$$

**1st Case.** If the load had been applied gradually, the stress induced is given by,

$$\sigma_1 = \frac{\text{Load}}{\text{Area}} = \frac{P}{A} = 3.4 \text{ N/mm}^2. \text{ Ans.}$$

**2nd Case.** If the load had fallen from a height of 47.5 mm.

Let  $\sigma_2$  = Maximum stress induced.

Using equation (4.7), we get

$$\begin{aligned} \sigma_2 &= \frac{P}{A} \left[ 1 + \sqrt{1 + \frac{2AEh}{P \times L}} \right] \quad [\text{Here } \sigma = \sigma_2] \\ &= 3.4 \left[ 1 + \sqrt{1 + \frac{2 \times 2.1 \times 10^5 \times 47.5}{3.4 \times 1820}} \right] \quad \left( \because \frac{P}{A} = 3.4, h = 47.5 \right) \\ &= 3.4 (1 + \sqrt{1 + 3219.24}) \\ &= 196.64 \text{ N/mm}^2. \text{ Ans.} \end{aligned}$$

**Problem 4.16.** A vertical compound tie member fixed rigidly at its upper end, consists of a steel rod 2.5 m long and 200 mm in diameter, placed within an equally long brass tube 21 mm in internal diameter and 30 mm external diameter. The rod and the tube are fixed together at the ends. The compound member is then suddenly loaded in tension by a weight of 10 kN falling through a height of 3 mm on to a flange fixed to its lower end. Calculate the maximum stresses in steel and brass. Assume  $E_s = 2 \times 10^5 \text{ N/mm}^2$  and  $E_b = 1.0 \times 10^5 \text{ N/mm}^2$ .

**Sol.** Given :

Length of steel rod,  $L = 2.5 \text{ m} = 2500 \text{ mm}$

Dia. of steel rod,  $d_s = 20 \text{ mm}$

$$\begin{aligned} \therefore \text{Area of steel rod, } A_s &= \frac{\pi}{4} \times 20^2 \\ &= 100 \pi \text{ mm}^2 \end{aligned}$$

Internal dia. of brass tube = 21 mm

External dia. of brass tube = 30 mm

$$\begin{aligned} \therefore \text{Area of brass tube, } A_b &= \frac{\pi}{4} (30^2 - 21^2) \\ &= 114.75 \pi \text{ mm}^2 \end{aligned}$$

Length of brass tube, = 250 cm  
= 2500 mm

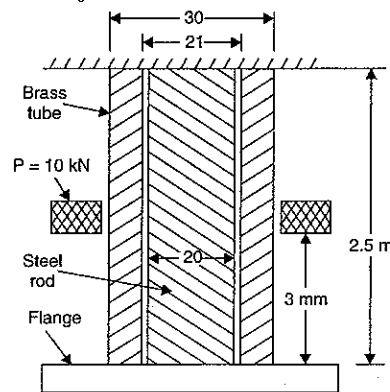

Fig. 4.5

Weight,  $P = 10 \text{ kN} = 10,000 \text{ N}$

Height through which weight falls,

$$h = 3 \text{ mm}$$

Young's modulus for steel,  $E_s = 2 \times 10^5 \text{ N/mm}^2$

Young's modulus for brass,  $E_b = 1.0 \times 10^5 \text{ N/mm}^2$

Let  $\sigma_s$  = Stress in steel tube, and

$\sigma_b$  = Stress in brass tube.

As both the ends are fixed together,

Strain in steel rod = Strain in brass tube

$$\text{i.e., } \frac{\sigma_s}{E_s} = \frac{\sigma_b}{E_b} \quad \left[ \because \text{Strain} = \frac{\text{Stress}}{E} \right]$$

$$\text{or } \sigma_s = \frac{\sigma_b}{E_b} \times E_s = \sigma_b \times \frac{2 \times 10^5}{1 \times 10^5} = 2 \times \sigma_b \quad \dots(i)$$

Now volume of steel rod,  $V_s = \text{Area} \times \text{Length}$

$$= A_s \times L = 100 \pi \times 2500$$

$$= 250000 \pi \text{ mm}^3$$

Volume of brass tube,  $V_b = A_b \times L = 114.75 \pi \times 2500 = 286875 \pi \text{ mm}^3$

$\therefore$  Strain energy stored in steel rod,

$$\begin{aligned} U_s &= \frac{\sigma_s^2}{2E_s} \times V_s = \frac{(2 \times \sigma_b)^2}{2 \times 2 \times 10^5} \times 250000 \pi \quad (\because \sigma_s = 2\sigma_b) \\ &= 7.854 \sigma_b^2. \end{aligned}$$

and strain energy stored in brass tube,

$$\begin{aligned} U_b &= \frac{\sigma_b^2}{2E_b} \times V_b = \frac{\sigma_b^2}{2 \times 1 \times 10^5} \times 286875 \pi \\ &= 4.506 \sigma_b^2. \end{aligned}$$

Total strain energy stored in the compound bar;

$$\begin{aligned} U &= U_s + U_b \\ &= 7.854 \sigma_b^2 + 4.506 \sigma_b^2 \\ &= 12.36 \sigma_b^2. \end{aligned} \quad \dots(ii)$$

Work done by the falling weight = Weight ( $h + \delta L$ )

$$= 10000 (3 + \delta L) \quad \dots(iii)$$

As both the ends are fixed,

The strain in steel rod = Strain in brass rod

$$\text{But strain in brass rod} = \frac{\sigma_b}{E_b} \quad \left( \because \text{Strain} = \frac{\text{Stress}}{E} \right)$$

or

$$\frac{\delta L}{L} = \frac{\sigma_b}{1 \times 10^6}$$

$$\begin{aligned} \therefore \delta L &= \frac{\sigma_b}{1 \times 10^6} \times 2500 \quad (\because L = 2500 \text{ mm}) \\ &= 0.025 \sigma_b. \end{aligned}$$



Substituting this value of  $\delta L$  in equation (iii), we get

$$\text{Work done by falling weight} = 10000 (3.0 + 0.025 \sigma_b) \quad \dots(iv)$$

Now equating the work done by the falling weight to the total strain energy stored [i.e., equating equations (iv) and (ii)], we get

$$10000 [3 + 0.025 \sigma_b] = 12.36 \sigma_b^2$$

$$\text{or} \quad 30000 + 250 \sigma_b = 12.36 \sigma_b^2$$

$$\text{or} \quad 12.36 \sigma_b^2 - 250 \sigma_b - 30000 = 0$$

$$\text{or} \quad \sigma_b^2 - \frac{250}{12.36} \sigma_b - \frac{30000}{12.36} = 0$$

$$\text{or} \quad \sigma_b^2 - 20.226 \sigma_b - 2427.18 = 0$$

The above equation is a quadratic equation.

$$\begin{aligned} \therefore \sigma_b &= \frac{20.226 \pm \sqrt{20.226^2 + 4 \times 2427.18}}{2} \\ &= \frac{20.226 \pm \sqrt{409.09 + 9708.72}}{2} \\ &= \frac{20.226 \pm 100.587}{2} \\ &= \frac{20.226 + 100.587}{2} \quad (\text{Neglecting -ve root}) \\ &= 60.4 \text{ N/mm}^2. \quad \text{Ans.} \end{aligned}$$

$$\begin{aligned} \text{From equation (i), we get } \sigma_s &= 2 \times \sigma_b = 2 \times 60.4 \\ &= 120.8 \text{ N/mm}^2. \quad \text{Ans.} \end{aligned}$$

**Problem 4.17.** A vertical bar 4 metre long and of 2000 mm<sup>2</sup> cross-sectional area is fixed at the upper end and has a collar at the lower end. Determine the maximum stress induced when a weight of :

(i) 3000 N falls through a height of 20 cm on the collar,

(ii) 30 kN falls through a height of 2 cm on the collar.

Take  $E = 2.0 \times 10^5 \text{ N/mm}^2$ .

**Sol. Given :**

$$\text{Length of bar, } L = 4 \text{ m} = 4000 \text{ mm}$$

$$\text{Area of bar, } A = 2000 \text{ mm}^2$$

$$\therefore \text{Volume of bar, } V = A \times L = 2000 \times 4000 = 8000,000 \text{ mm}^3$$

**1st Case.** Falling weight,  $P_1 = 3000 \text{ N}$

$$\text{Height, } h_1 = 20 \text{ cm} = 200 \text{ mm}$$

Let  $\sigma_1 =$  Maximum stress induced.

In this case the falling weight is small as compared to second case. The small weight will produce a small extension of the bar. Hence the extension in the bar will be negligible as compared to the height of 20 cm through which the weight falls.

$\therefore$  Using equation (4.8), we get

$$\sigma = \sqrt{\frac{2EP_h}{A.L}}$$

$$\text{or} \quad \sigma_1 = \sqrt{\frac{2EP_1 h_1}{A.L}}$$

$$\text{or} \quad \sigma_1 = \sqrt{\frac{2 \times 2 \times 10^5 \times 3000 \times 200}{2000 \times 4000}}$$

$$(\because A = 2000 \text{ mm}^2, L = 4000 \text{ mm})$$

$$= 173.2 \text{ N/mm}^2. \quad \text{Ans.}$$

**2nd Case.** Falling weight,  $P_2 = 30 \text{ kN} = 30000 \text{ N}$

$$\text{Height, } h_2 = 2 \text{ cm} = 20 \text{ mm}$$

Let  $\sigma_2 =$  Maximum stress induced.

In this case falling weight is having a large value. Hence the extension produced by a large weight will be large. Moreover the height through which this weight falls is 2 cm only. Hence the extension in the bar, in comparison to the height through which weight falls, is not negligible.

$\therefore$  Using equation (4.7), we get

$$\sigma = \frac{P}{A} \left[ 1 + \sqrt{1 + \frac{2AEh}{P.L}} \right]$$

$$\text{or} \quad \sigma_2 = \frac{P_2}{A} \left[ 1 + \sqrt{1 + \frac{2AEh_2}{P_2.L}} \right]$$

$$= \frac{30000}{2000} \left[ 1 + \sqrt{1 + \frac{2 \times 2000 \times 2 \times 10^5 \times 20}{30000 \times 4000}} \right]$$

$$= 15 (1 + 11.590) = 188.85 \text{ N/mm}^2. \quad \text{Ans.}$$

**Problem 4.18.** A crane-chain whose sectional area is 6.25 cm<sup>2</sup> carries a load of 10 kN. As it is being lowered at a uniform rate of 40 m per minute, the chain gets jammed suddenly, at which time the length of the chain unwound is 10 m. Estimate the stress induced in the chain due to the sudden stoppage. Neglect the weight of the chain. Take  $E = 2.1 \times 10^5 \text{ N/mm}^2$ .

(AMIE, Summer 1989)

**Sol. Given :**

$$\text{Area, } A = 6.25 \text{ cm}^2 = 625 \text{ mm}^2$$

$$\text{Load, } W = 10 \text{ kN} = 10,000 \text{ N}$$

$$\text{Velocity, } V = 40 \text{ m/min} = \frac{40}{60} \text{ m/s} = \frac{2}{3} \text{ m/s}$$

$$\text{Length of chain unwound} = 10 \text{ m} = 10 \times 1000 \text{ mm}$$

$$\therefore L = 10,000 \text{ mm}$$

$$\text{Value of } E = 2.1 \times 10^5 \text{ N/mm}^2$$

Let  $\sigma =$  Stress induced in the chain due sudden stoppage.

$$\text{K.E. of the crane} = \frac{1}{2} m V^2 = \frac{1}{2} \left( \frac{W}{g} \right) \times V^2$$

$$= \frac{1}{2} \left( \frac{10000}{9.81} \right) \times \left( \frac{2}{3} \right)^2 \text{ N m} = 226.5 \text{ N m}$$

$$= 226.5 \times 1000 \text{ N mm} = 226500 \text{ N mm} \quad \dots(i)$$

When the chain gets jammed suddenly, the whole of the K.E. of the crane is absorbed in the chain. But the energy stored or absorbed in the chain

$$= \frac{\sigma^2}{2E} \times A \times L$$

$$= \frac{\sigma^2}{2 \times 2.1 \times 10^5} \times 625 \times 10,000 \text{ N mm} \quad \dots(ii)$$

Now K.E. of crane = Energy stored in the chain

$$\text{or} \quad 226500 = \frac{\sigma^2}{2 \times 2.1 \times 10^5} \times 625 \times 10,000$$

$$\therefore \sigma^2 = \frac{226500 \times 2 \times 2.1 \times 10^5}{625 \times 10,000}$$

$$\therefore \sigma = \sqrt{\frac{226500 \times 2 \times 2.1 \times 10^5}{625 \times 10,000}}$$

$$= 123.37 \text{ N/mm}^2. \text{ Ans.}$$

**Problem 4.19.** A cage weighing 60 kN is attached to the end of a steel wire rope. It is lowered down a mine shaft with a constant velocity of 1 m/s. What is the maximum stress produced in the rope when its supporting drum is suddenly jammed? The free length of the rope at the moment of jamming is 15 m, its net cross-sectional area is 25 cm<sup>2</sup> and  $E = 2 \times 10^5 \text{ N/mm}^2$ . The self-weight of the wire rope may be neglected. (AMIE, Winter 1990)

**Sol.** Given :

Weight,	$W = 60 \text{ kN} = 60,000 \text{ N}$
Velocity,	$V = 1 \text{ m/s}$
Free length,	$L = 15 \text{ m} = 15,000 \text{ mm}$
Area,	$A = 25 \text{ cm}^2 = 25 \times 100 \text{ mm}^2$
Value of	$E = 2 \times 10^5 \text{ N/mm}^2$

$$\text{K.E. of the cage} = \frac{1}{2} mV^2 = \frac{1}{2} \left( \frac{W}{g} \right) \times V^2$$

$$= \frac{1}{2} \times \left( \frac{60,000}{9.81} \right) \times 1^2 \text{ N m} = \frac{30000}{9.81} \text{ N m}$$

$$= \frac{30000 \times 1000}{9.81} \text{ N mm} \quad \dots(i)$$

This energy is to be absorbed (or stored) by the rope.

Let  $\sigma$  = Maximum stress produced in the rope when its supporting drum is suddenly jammed.

But the maximum energy stored

$$= \frac{\sigma^2}{2E} \times A \times L = \frac{\sigma^2}{2 \times 2 \times 10^5} \times 2500 \times 15000 \text{ N mm} \quad \dots(ii)$$

But K.E. of the cage = Energy stored in the rope

$$\frac{30000 \times 1000}{9.81} = \frac{\sigma^2}{2 \times 2 \times 10^5} \times 2500 \times 15000$$

or

$$\sigma^2 = \frac{30000 \times 1000 \times 2 \times 2 \times 10^5}{9.81 \times 2500 \times 15000}$$

or

$$\sigma = \sqrt{\frac{30000 \times 1000 \times 2 \times 2 \times 10^5}{9.81 \times 2500 \times 15000}} = 180.61 \text{ N/mm}^2. \text{ Ans.}$$

#### 4.6. EXPRESSION FOR STRAIN ENERGY STORED IN A BODY DUE TO SHEAR STRESS

Fig 4.6 shows a rectangular block of length  $l$ , height  $h$  and breadth  $b$ , fixed at the bottom face  $AB$ . Let a shear force  $P$  is applied on the top face  $CD$  and hence the top face moves a distance equal to  $CC_1$ .

Let  $\tau$  = Shear stress produced,  
 $\phi$  = Shear strain, and  
 $C$  = Modulus of rigidity.

Now shear stress,

$$\tau = \frac{\text{Shear force}}{\text{Area}}$$

( $\because$  Area of top face =  $l \times b$ )

$$= \frac{P}{l \times b}$$

$$\therefore P = \tau \times l \times b$$

$$\text{and shear strain, } \phi = \frac{CC_1}{CB}$$

$$\therefore CC_1 = CB \cdot \phi$$

If the shear force  $P$  is applied gradually, then average load will be equal to  $\frac{P}{2}$ .

$\therefore$  Work done by gradually applied shear force

$$= \text{Average load} \times \text{Distance}$$

$$= \frac{P}{2} \times CC_1 = \frac{1}{2} (\tau \times l \times b) \cdot (CB \cdot \phi)$$

$$(\because p = \tau \times l \times b \text{ and } CC_1 = CB \cdot \phi)$$

$$= \frac{1}{2} \cdot \tau \cdot l \times b \times h \cdot \phi \quad (\because CB = h)$$

$$= \frac{1}{2} \cdot \tau \times \phi \times l \times b \times h = \frac{1}{2} \cdot \tau \times \frac{\tau}{C} \times \text{Volume of block}$$

$$\left( \because \phi = \text{Shear strain} = \frac{\text{Shear strain}}{C} \right)$$

$$= \frac{1}{2} \times \frac{\tau^2}{C} \times V$$

$$(\because V = l \times b \times h)$$

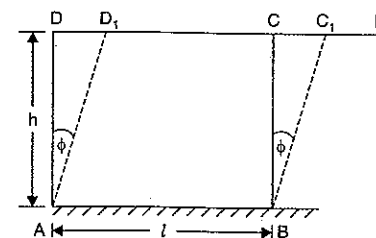

Fig. 4.6

But the work done is equal to the strain energy stored.

$$\therefore \text{Strain energy stored} = \frac{\tau^2}{2C} \times V \quad \dots(4.9)$$

**Problem 4.20.** The shear stress in a material at a point is given as 50 N/mm<sup>2</sup>. Determine the local strain energy per unit volume stored in the material due to shear stress. Take  $C = 8 \times 10^4$  N/mm<sup>2</sup>.

**Sol.** Given :

Shear stress,  $\tau = 50$  N/mm<sup>2</sup>

Modulus of rigidity,  $C = 8 \times 10^4$  N/mm<sup>2</sup>

Using equation (4.9),

$$\begin{aligned} \text{Strain energy} &= \frac{\tau^2}{2C} \times \text{Volume} = \frac{50^2}{2 \times 8 \times 10^4} \times \text{Volume} \\ &= 0.015625 \times \text{Volume} \end{aligned}$$

$\therefore$  Strain energy per unit volume

$$= \frac{0.015625 \times \text{Volume}}{\text{Volume}} = 0.015625 \text{ N/mm}^2. \quad \text{Ans.}$$

### HIGHLIGHTS

1. The energy stored in a body due to straining effect is known as strain energy.
2. Resilience is the total strain energy stored in a body. Resilience is also defined as the capacity of a strained body for doing work on the removal of the straining force.
3. The maximum strain energy stored in a body is known as proof resilience. The proof resilience is given by,

$$\text{Proof resilience} = \frac{\sigma^2}{2E} \times \text{Volume}$$

where  $\sigma$  = Stress at the elastic limit.

4. The proof resilience of a body per unit volume is known as modulus of resilience.
5. The maximum stress induced in a body is given by

$$\begin{aligned} \sigma &= \frac{P}{A} \dots \text{if the load } P \text{ is applied gradually} \\ &= 2 \frac{P}{A} \dots \text{if the load } P \text{ is applied suddenly} \\ &= \frac{P}{A} \left( 1 + \sqrt{1 + \frac{2AEh}{P.L}} \right) \dots \text{if the load } P \text{ is applied with impact} \end{aligned}$$

where  $A$  = Cross-sectional area of the body,  
 $h$  = Height through which load falls,  
 $E$  = Modulus of rigidity,  
 $L$  = Length of the body.

6. The maximum stress induced in a body due to suddenly applied load is twice the stress induced when the same load is applied gradually.
7. If the extension produced in a rod due to impact load is very small in comparison with the height through which the load falls, then the maximum stress induced in body is given by

$$\sigma = \sqrt{\frac{2E.P.h}{A.L}}$$

where  $P$  = Impact load,

$h$  = Height through which load falls.

8. To find the expression for the stress induced in a body either by suddenly applied load or by an impact load, the strain energy stored in a body is equated to the work done by the load.
9. The energy stored in a body due to shear stress ( $\tau$ ) is given by

$$U = \frac{\tau^2}{2C} \times V$$

where  $V$  = Volume of the body, and

$C$  = Modulus of rigidity.

### EXERCISE 4

#### (A) Theoretical Questions

1. Define the following terms :  
 (i) Resilience (ii) Strain energy  
 (iii) Impact loading, and (iv) Spring.
2. Define resilience, proof resilience and modulus of resilience.
3. Find an expression for the strain energy stored in a body when  
 (i) the load is applied gradually (ii) the load is applied suddenly and  
 (iii) the load is applied with an impact.
4. Prove that the maximum stress induced in a body due to suddenly applied load is twice the stress induced when the same load is applied gradually.
5. Derive an expression for the stress induced in a body due to suddenly applied load and hence find the value of extension produced in the body.
6. Prove that the maximum strain energy stored in a body is given by,

$$U = \frac{\sigma^2}{2E} \times \text{Volume}$$

where  $\sigma$  = Stress at the elastic limit.

7. Explain the terms : Gradually applied load, suddenly applied load, and load applied with an impact.
8. Prove that the stress induced in a body when the load is applied with impact is given by,

$$\sigma = \frac{P}{A} \left( 1 + \sqrt{1 + \frac{2AEh}{P.L}} \right)$$

where  $P$  = Load applied with impact,  $A$  = Cross-sectional area of the body,  
 $h$  = height through which load falls,  $L$  = Length of the body, and  
 $E$  = Modulus of elasticity.

9. If the extension produced in a rod due to impact load is very small in comparison with the height through which the load falls, prove that stress induced in the body will be given by

$$\sigma = \sqrt{\frac{2EPh}{A.L}}$$

10. Prove that the strain energy stored in a body due to shear stress is given by,

$$U = \frac{\tau^2}{2C} \times V$$

where  $\tau$  = Shear stress,

$C$  = Modulus of rigidity, and

$V$  = Volume of the body.

11. Explain the following terms : (i) Proof stress, (ii) Proof resilience, and (iii) Modulus of resilience.  
(Bhavnagar University, Feb. 1992)

**(B) Numerical Problems**

1. A tensile load of 50 kN is gradually applied to a circular bar of 5 cm diameter and 4 m long. If the value of  $E = 2.0 \times 10^5 \text{ N/mm}^2$ , determine : (i) stretch in the rod, (ii) stress in the rod, and (iii) strain energy absorbed by the rod. [Ans. (i) 0.0509 cm, (ii) 25.465 N/mm<sup>2</sup> (iii) 12.73 Nm]
2. If in question 1, the tensile load of 50 kN is applied suddenly, determine : (i) maximum instantaneous stress induced, (ii) instantaneous elongation in the rod, and (iii) strain energy absorbed in the rod. [Ans. (i) 50.93 N/mm<sup>2</sup>, (ii) 0.1018 cm (iii) 50.93 Nm]
3. Calculate instantaneous stress produced in a bar 10 cm<sup>2</sup> in area and 4 m long by the sudden application of a tensile load of unknown magnitude, if the extension of the bar due to suddenly applied load is 1.35 mm. Also determine the suddenly applied load. Take  $E = 2 \times 10^5 \text{ N/mm}^2$ .  
[Ans. 67.5 N/mm<sup>2</sup>, 33.75 kN]
4. A uniform metal bar has a cross-sectional area of 6 cm<sup>2</sup> and a length of 1.4 m. If the stress at the elastic limit is 1.5 tonne/cm<sup>2</sup>, find the proof resilience of the bar. Determine also the maximum value of an applied load, which may be suddenly applied without exceeding the elastic limit. Calculate the value of the gradually applied load which will produced the same extension as that produced by the suddenly applied load above. Take  $E = 2000 \text{ tonnes/cm}^2$ .
5. A tension bar 6 m long is made up of two parts, 4 metre of its length has a cross-sectional area 12.5 cm<sup>2</sup> while the remaining 2 m length has a cross-sectional area of 25 cm<sup>2</sup>. An axial load of 5 tonnes is gradually applied. Find the total strain energy produced in the bar and compare this value with that obtained in a uniform bar of the same length and having the same volume when under the same load. Take  $E = 2 \times 10^6 \text{ kgf/cm}^2$ .  
[Ans. 242 kgf/cm, 1.054]
6. A load of 200 N falls through a height of 2.5 cm on to a collar rigidly attached to the lower end of a vertical bar 2 m long and of 3 cm<sup>2</sup> cross-sectional area. The upper end of the vertical bar is fixed. Determine : (i) maximum instantaneous stress induced in the vertical bar, (ii) maximum instantaneous elongation, and (iii) strain energy stored in the vertical rod. Take  $E = 2 \times 10^6 \text{ kgf/cm}^2$ .  
[Ans. (i) 58.4 N/mm<sup>2</sup> (ii) 0.0584 cm (iii) 511.5 Nm]
7. The maximum instantaneous, produced by an unknown falling weight through a height of 4 cm in a vertical bar of length 5 m and of cross-sectional area 5 cm<sup>2</sup>, is 1.80 mm. Determine : (i) the instantaneous stress induced in the vertical bar and (ii) the values of unknown weight.  
Take  $E = 2 \times 10^6 \text{ kgf/cm}^2$ .  
[Ans. (i) 72 N/mm<sup>2</sup> and (ii) 775.1 N]
8. An unknown weight falls through a height of 20 mm on a collar rigidly attached to the lower end of a vertical bar 5 m long and 800 mm<sup>2</sup> in section. If the maximum extension of the rod is to be 2.5 mm, what is the corresponding stress and magnitude of the unknown weight ? Take  $E = 2.0 \times 10^6 \text{ kgf/cm}^2$ .  
[Ans. 1000 kgf/cm<sup>2</sup>, 444.44 kgf]
9. A bar 1.5 cm diameter gets stretched by 2.5 mm under a steady load of 100 kgf. What stress would be produced in the same bar by a weight of 120 kgf, which falls vertically through a distance 5 cm on to a rigid collar attached at its end ? The bar is initially unstressed. Take  $E = 2.0 \times 10^6 \text{ kgf/cm}^2$ .  
[Ans. 1309.44 kgf/cm<sup>2</sup>]
10. A vertical round steel rod 2 m long is securely held at its upper end. A weight can slide freely on the rod and its fall is arrested by a stop provided at the lower end of the rod. When the weight falls from a height of 2.5 cm above the stop, the maximum stress reached in the rod is estimated to be 1450 kgf/cm<sup>2</sup>. Determine the stress in the rod if the load had been applied gradually and also the maximum stress if the load had fallen from a height of 4.5. Take  $E = 2.0 \times 10^6 \text{ kgf/cm}^2$ .  
[Ans. 39.743 kgf/cm<sup>2</sup>, 193.42 kgf/cm<sup>2</sup>]
11. A vertical compound tie member fixed rigidly at its upper end, consists of a steel rod 3 m long and 20 mm diameter, placed within an equally long brass tube 20 mm internal diameter and 20 mm external diameter. The rod and the tube are fixed together at the ends. The compound member is then suddenly loaded in tension by a weight of 1200 kgf falling through a height of

- 5 mm on to a flange fixed to its lower end. Calculate the maximum stresses in steel and brass. Assume  $E_s = 2 \times 10^6 \text{ kgf/cm}^2$  and  $E_b = 1.0 \times 10^6 \text{ kgf/cm}^2$ . [Ans. 1173.5 kgf/cm<sup>2</sup>, 586.76 kgf/cm<sup>2</sup>]
12. A circular rod 5 cm in diameter and 3 metre long hangs vertically and has a collar securely attached to the lower end. Find the maximum stress induced : (i) when a weight of 250 kgf falls through 15 cm on the collar, (ii) when a weight of 2500 kgf falls 1.5 cm on the collar. Take  $E = 2.1 \times 10^6 \text{ kgf/cm}^2$ .  
[Ans. (i) 1635 kgf/cm<sup>2</sup>, (ii) 1767 kgf/cm<sup>2</sup>]
  13. The shear stress in a material at a point is given as 45 N/mm<sup>2</sup>. Determine the local strain energy per unit volume stored in the material due to shear stress. Take  $C = 8 \times 10^4 \text{ N/mm}^2$ .  
[Ans. 0.01265 N/mm<sup>2</sup>]

# Centre of Gravity and Moment of Inertia

## 5.1. CENTRE OF GRAVITY

Centre of gravity of a body is the point through which the whole weight of the body acts. A body is having only one centre of gravity for all positions of the body. It is represented by C.G. or simply G.

## 5.2. CENTROID

The point at which the total area of a plane figure (like rectangle, square, triangle, quadrilateral, circle etc.) is assumed to be concentrated, is known as the centroid of that area. The centroid is also represented by C.G. or simply G. The centroid and centre of gravity are at the same point.

## 5.3. CENTROID OR CENTRE OF GRAVITY OF SIMPLE PLANE FIGURES

- (i) The centre of gravity (C.G.) of a uniform rod lies at its middle point.
- (ii) The centre of gravity of a triangle lies at the point where the three medians\* of the triangle meet.
- (iii) The centre of gravity of a rectangle or of a parallelogram is at the point, where its diagonal meet each other. It is also the point of intersection of the lines joining the middle points of the opposite sides.
- (iv) The centre of gravity of a circle is at its centre.

## 5.4. CENTROID (OR CENTRE OF GRAVITY) OF AREAS OF PLANE FIGURES BY THE METHOD OF MOMENTS

Fig. 5.1 shows a plane figure of total area  $A$  whose centre of gravity is to be determined. Let this area  $A$  is composed of a number of small areas  $a_1, a_2, a_3, a_4, \dots$  etc.

$$A = a_1 + a_2 + a_3 + a_4 + \dots$$

Let  $x_1$  = The distance of the C.G. of the area  $a_1$  from axis  $OY$

$x_2$  = The distance of the C.G. of the area  $a_2$  from axis  $OY$

$x_3$  = The distance of the C.G. of the area  $a_3$  from axis  $OY$

$x_4$  = The distance of the C.G. of the area  $a_4$  from axis  $OY$

and so on.

The moments of all small areas about the axis  $OY$

$$= a_1x_1 + a_2x_2 + a_3x_3 + a_4x_4 + \dots \quad \dots(i)$$

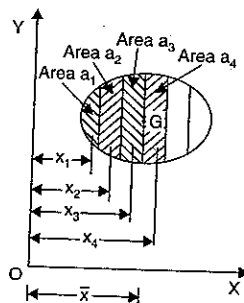

Fig. 5.1

\*The line connecting the vertex and the middle point of the opposite side of a triangle is known as median of the triangle.

Let  $G$  is the centre of gravity of the total area  $A$  whose distance from the axis  $OY$  is  $\bar{x}$ .

Then moment of total area about  $OY = A\bar{x}$  ...(ii)

The moments of all small areas about the axis  $OY$  must be equal to the moment of total area about the same axis. Hence equating equations (i) and (ii), we get

$$a_1x_1 + a_2x_2 + a_3x_3 + a_4x_4 + \dots = A\bar{x}$$

or 
$$\bar{x} = \frac{a_1x_1 + a_2x_2 + a_3x_3 + a_4x_4 + \dots}{A} \quad \dots(5.1)$$

where  $A = a_1 + a_2 + a_3 + a_4 \dots$

If we take the moments of the small areas about the axis  $OX$  and also the moment of total area about the axis  $OX$ , we will get

$$\bar{y} = \frac{a_1y_1 + a_2y_2 + a_3y_3 + a_4y_4 + \dots}{A} \quad \dots(5.2)$$

where  $\bar{y}$  = The distance of  $G$  from axis  $OX$

$y_1$  = The distance of C.G. of the area  $a_1$  from axis  $OX$

$y_2, y_3, y_4$  = The distance of C.G. of area  $a_2, a_3, a_4$  from axis  $OX$  respectively.

**5.4.1. Centre of Gravity of Areas of Plane Figures by Integration Method.** The equations (5.1) and (5.2) can be written as

$$\bar{x} = \frac{\sum a_i x_i}{\sum a_i} \quad \text{and} \quad \bar{y} = \frac{\sum a_i y_i}{\sum a_i}$$

where  $i = 1, 2, 3, 4, \dots$

$x_i$  = Distance of C.G. of area  $a_i$  from axis  $OY$  and

$y_i$  = Distance of C.G. of area  $a_i$  from axis  $OX$ .

The value of  $i$  depends upon the number of small areas. If the small areas are large in number (mathematically speaking infinite in number), then the summations in the above equations can be replaced by integration. Let the small areas are represented by  $dA$  instead of 'a', then the above equations are written as :

$$\bar{x} = \frac{\int x^* dA}{\int dA} \quad \dots(5.2 A)$$

and 
$$\bar{y} = \frac{\int y^* dA}{\int dA} \quad \dots(5.2 B)$$

where  $\int x^* dA = \sum x_i a_i$

$$\int dA = \sum a_i$$

$$\int y^* dA = \sum y_i a_i$$

Also  $x^*$  = Distance of C.G. of area  $dA$  from axis  $OY$

$y^*$  = Distance of C.G. of area  $dA$  from axis  $OX$ .

**5.4.2. Centroid (or Centre of Gravity) of a Line.** The centre of gravity of a line which may be straight or curve, is obtained by dividing the given line, into a large number of small lengths as shown in Fig. 5.1 (a).

The centre of gravity is obtained by replacing  $dA$  by  $dL$  in equations (5.2 A) and (5.2 B).

Then these equations become 
$$\bar{x} = \frac{\int x^* dL}{\int dL} \quad \dots(5.2 C)$$

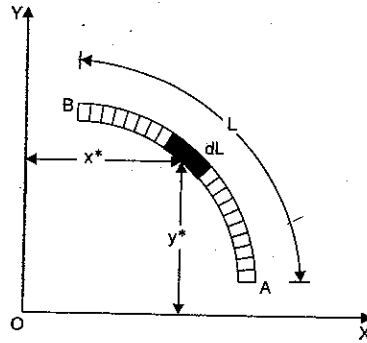

Fig. 5.1 (a)

and 
$$\bar{y} = \frac{\int y^* dL}{\int dL} \quad \dots(5.2 D)$$

where  $x^*$  = Distance of C.G. of length  $dL$  from  $y$ -axis, and  
 $y^*$  = Distance of C.G. of length  $dL$  from  $x$ -axis.

If the lines are straight, then the above equations are written as :

$$\bar{x} = \frac{L_1 x_1 + L_2 x_2 + L_3 x_3 + \dots}{L_1 + L_2 + L_3 + \dots} \quad \dots(5.2 E)$$

and 
$$\bar{y} = \frac{L_1 y_1 + L_2 y_2 + L_3 y_3 + \dots}{L_1 + L_2 + L_3 + \dots} \quad \dots(5.2 F)$$

**5.5. IMPORTANT POINTS**

- (i) The axis, about which moments of areas are taken, is known as axis of reference. In the above article, axis  $OX$  and  $OY$  are called axis of reference.
- (ii) The axis of reference, of plane figures, is generally taken as the lowest line of the figure for determining  $\bar{y}$ , and left line of the figure for calculating  $\bar{x}$ .
- (iii) If the given section is symmetrical about  $X-X$  axis or  $Y-Y$  axis, then the C.G. of the section will lie on the axis is symmetry.

**5.5.1. Centre of Gravity of Composite Bodies.** The centre of gravity of composite bodies or sections like  $T$ -section,  $I$ -section,  $L$ -sections etc. are obtained by splitting them into rectangular components. Then equations (5.1) and (5.2) are used.

**Problem 5.1.** Find the centre of gravity of the  $T$ -section shown in Fig. 5.2 (a).

**Sol.** The given  $T$ -section is split up into two rectangles  $ABCD$  and  $EFGH$  as shown in Fig. 5.2 (b). The given  $T$ -section is symmetrical about  $Y-Y$  axis. Hence the C.G. of the section will lie on this axis. The lowest line of the figure is line  $GF$ . Hence the moments of the areas are taken about this line  $GF$ , which is the axis of reference in this case.

Let  $\bar{y}$  = The distance of the C.G. of the  $T$ -section from the bottom line  $GF$   
 (which is axis of reference)

$a_1$  = Area of rectangle  $ABCD = 12 \times 3 = 36 \text{ cm}^2$

$y_1$  = Distance of C.G. of area  $a_1$  from bottom line  $GF = 10 + \frac{3}{2} = 11.5 \text{ cm}$

$a_2$  = Area of rectangle  $EFGH = 10 \times 3 = 30 \text{ cm}^2$

$y_2$  = Distance of C.G. of area  $a_2$  from bottom line  $GF = \frac{10}{2} = 5 \text{ cm}$ .

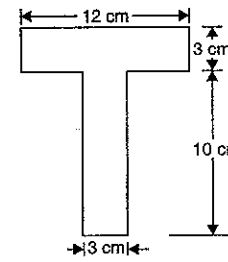

Fig. 5.2 (a)

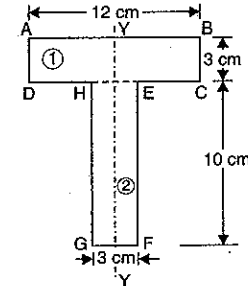

Fig. 5.2 (b)

Using equation (5.2), we have

$$\bar{y} = \frac{a_1 y_1 + a_2 y_2}{A} = \frac{a_1 y_1 + a_2 y_2}{a_1 + a_2} \quad (\because A = a_1 + a_2)$$

$$= \frac{36 \times 11.5 + 30 \times 5}{36 + 30} = \frac{414 + 150}{66} = 8.545 \text{ cm. Ans.}$$

**Problem 5.2.** Find the centre of gravity of the  $I$ -section shown in Fig. 5.3 (a).

**Sol.** The  $I$ -section is split up into three rectangles  $ABCD$ ,  $EFGH$  and  $JKLM$  as shown in Fig. 5.3 (b). The given  $I$ -section is symmetrical about  $Y-Y$  axis. Hence the C.G. of the section will lie on this axis. The lowest line of the figure line is  $ML$ . Hence the moments of areas are taken about this line, which is the axis of reference.

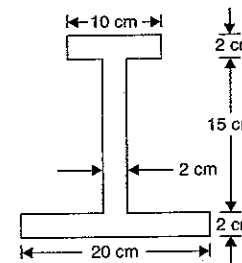

(a)

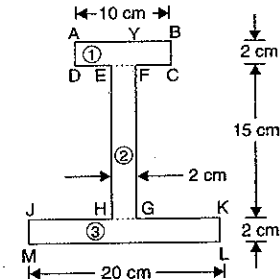

(b)

Fig. 5.3

Let  $\bar{y}$  = Distance of the C.G. of the  $I$ -section from the bottom line  $ML$

$a_1$  = Area of rectangle  $ABCD = 10 \times 2 = 20 \text{ cm}^2$

$y_1$  = Distance of C.G. of rectangle  $ABCD$  from bottom line  $ML = 2 + 15 + \frac{2}{2} = 18 \text{ cm}$

$a_2 = \text{Area of rectangle } EFGH = 15 \times 2 = 30 \text{ cm}^2$

$y_2 = \text{Distance of C.G. of rectangle } EFGH \text{ from bottom line } ML = 2 + \frac{15}{2} = 2 + 7.5 = 9.5 \text{ cm}$

$a_3 = \text{Area of rectangle } JKLM = 20 \times 2 = 40 \text{ cm}^2$

$y_3 = \text{Distance of C.G. of rectangle } JKLM \text{ from bottom line } ML = \frac{2}{2} = 1.0 \text{ cm}$

Now using equation (5.2), we have  $\bar{y} = \frac{a_1y_1 + a_2y_2 + a_3y_3}{A}$

$$\begin{aligned} &= \frac{a_1y_1 + a_2y_2 + a_3y_3}{a_1 + a_2 + a_3} \quad (\because A = a_1 + a_2 + a_3) \\ &= \frac{20 \times 18 + 30 \times 9.5 + 40 \times 1}{20 + 30 + 40} \\ &= \frac{360 + 285 + 40}{90} = \frac{685}{90} \\ &= 7.611 \text{ cm. Ans.} \end{aligned}$$

**Problem 5.3.** Find the centre of gravity of the L-section shown in Fig. 5.4.

**Sol.** The given L-section is not symmetrical about any section. Hence in this case, there will be two axis of references. The lowest line of the figure (i.e., line GF) will be taken as axis of reference for calculating  $\bar{y}$ . And the left line of the L-section (i.e., line AG) will be taken as axis of reference for calculating  $\bar{x}$ .

The given L-section is split up into two rectangles ABCD and DEFG, as shown in Fig. 5.4.

To Find  $\bar{y}$

Let  $\bar{y}$  = Distance of the C.G. of the L-section from bottom line GF

$a_1 = \text{Area of rectangle } ABCD = 10 \times 2 = 20 \text{ cm}^2$

$y_1 = \text{Distance of C.G. of rectangle } ABCD \text{ from bottom line } GF = 2 + \frac{10}{2} = 2 + 5 = 7 \text{ cm}$

$a_2 = \text{Area of rectangle } DEFG = 8 \times 2 = 16 \text{ cm}^2$

$y_2 = \text{Distance of C.G. of rectangle } DEFG \text{ from bottom line } GF = \frac{2}{2} = 1.0 \text{ cm.}$

Using equation (5.2), we have

$$\begin{aligned} \bar{y} &= \frac{a_1y_1 + a_2y_2}{A} \quad \text{where } A = a_1 + a_2 \\ &= \frac{a_1y_1 + a_2y_2}{a_1 + a_2} = \frac{20 \times 7 + 16 \times 1}{20 + 16} = \frac{140 + 16}{36} \\ &= \frac{156}{36} = \frac{13}{3} = 4.33 \text{ cm.} \end{aligned}$$

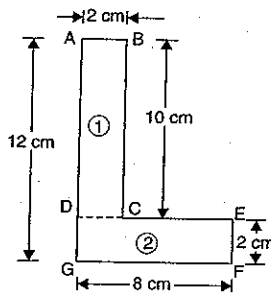

Fig. 5.4

To Find  $\bar{x}$

Let  $\bar{x}$  = Distance of the C.G. of the L-section from left line AG

$x_1 = \text{Distance of the rectangle } ABCD \text{ from left line } AG$

$= \frac{2}{2} = 1.0 \text{ cm}$

$x_2 = \text{Distance of the rectangle } DEFG \text{ from left line } AG$

$= \frac{8}{2} = 4.0 \text{ cm.}$

Using equation (5.1), we get

$$\begin{aligned} \bar{x} &= \frac{a_1x_1 + a_2x_2}{A} \quad \text{where } A = a_1 + a_2 \\ &= \frac{a_1x_1 + a_2x_2}{a_1 + a_2} = \frac{20 \times 1 + 16 \times 4}{20 + 16} \quad (\because a_1 = 20 \text{ and } a_2 = 16) \\ &= \frac{20 + 64}{36} = \frac{84}{36} = \frac{7}{3} = 2.33 \text{ cm.} \end{aligned}$$

Hence the C.G. of the L-section is at a distance of 4.33 cm from the bottom line GF and 2.33 cm from the left line AG. **Ans.**

**Problem 5.4.** Using the analytical method, determine the centre of gravity of the plane uniform lamina shown in Fig. 5.5. (U.P. Tech. University, 2001-2002 ; AMIE, Summer 1975)

**Sol.** Let  $\bar{y}$  be the distance between c.g. of the lamina and the bottom line AB.

Area 1

$a_1 = 10 \times 5 = 50 \text{ cm}^2$

$y_1 = \frac{5}{2} = 2.5 \text{ cm}$

Area 2

$a_2 = \frac{\pi}{2} \times r^2 = \frac{\pi}{2} \times 2.5^2 = 9.82 \text{ cm}^2$

$y_2 = \frac{5}{2} = 2.5 \text{ cm}$

Area 3

$a_3 = \frac{5 \times 5}{2} = 12.5 \text{ cm}^2$

$y_3 = 5 + \frac{5}{3} = 6.67 \text{ cm.}$

Using the relation,

$$\begin{aligned} \bar{y} &= \frac{a_1y_1 + a_2y_2 + a_3y_3}{a_1 + a_2 + a_3} \\ &= \frac{50 \times 2.5 + 9.82 \times 2.5 + 12.5 \times 6.67}{50 + 9.82 + 12.5} \text{ cm} = \frac{232.9}{72.32} = 3.22 \text{ cm.} \end{aligned}$$

Similarly, let  $\bar{x}$  be the distance between c.g. of the lamina and the left line CD.

Area 1

$a_1 = 50 \text{ cm}^2$

$x_1 = 2.5 + \frac{10}{2} = 7.5 \text{ cm}$

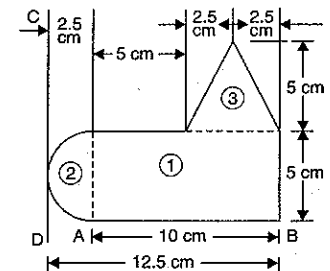

Fig. 5.5

Area 2

$$a_2 = 9.82 \text{ cm}^2$$

$$x_2 = 2.5 - \frac{4r}{3\pi} = 2.5 - \frac{4.25}{3\pi} \text{ cm} = 1.44 \text{ cm}$$

Area 3

$$a_3 = 12.5 \text{ cm}^2$$

$$x_3 = 2.5 + 5 + 2.5 = 10 \text{ cm.}$$

Now using the relation,

$$\bar{x} = \frac{a_1x_1 + a_2x_2 + a_3x_3}{a_1 + a_2 + a_3} = \frac{50 \times 7.5 + 9.82 \times 1.44 + 12.5 \times 10}{50 + 9.82 + 12.5} \text{ cm}$$

$$= \frac{514.14}{72.32} = 7.11 \text{ cm.}$$

Hence the C.G. of the uniform lamina is at a distance of 3.22 cm from the bottom line  $AB$  and 7.11 cm from the left line  $CD$ . **Ans.**

**Problem 5.5.** From a rectangular lamina  $ABCD$   $10 \text{ cm} \times 12 \text{ cm}$  a rectangular hole of  $3 \text{ cm} \times 4 \text{ cm}$  is cut as shown in Fig. 5.6.

Find the c.g. of the remainder lamina.

**Sol.** The section shown in Fig. 5.6, is having a cut hole. The centre of gravity of a section with a cut hole is determined by considering the main section first as a complete one, and then subtracting the area of the cut-out hole, i.e., by taking the area of the cut-out hole as negative.

Let  $\bar{y}$  is the distance between the C.G. of the section with a cut hole from the bottom line  $DC$ .

$$a_1 = \text{Area of rectangle } ABCD = 10 \times 12 = 120 \text{ cm}^2$$

$y_1 =$  Distance of C.G. of the rectangle  $ABCD$  from bottom line  $DC$

$$= \frac{12}{2} = 6 \text{ cm}$$

$$a_2 = \text{Area of cut-out hole, i.e., rectangle } EFGH,$$

$$= 4 \times 3 = 12 \text{ cm}^2$$

$$y_2 = \text{Distance of C.G. of cut-out hole from bottom line } DC$$

$$= 2 + \frac{4}{2} = 2 + 2 = 4 \text{ cm.}$$

Now using equation (5.2) and taking the area ( $a_2$ ) of the cut-out hole as negative, we get

$$\bar{y} = \left( \frac{a_1y_1 - a_2y_2}{A} \right)^* \quad \text{where } A = a_1 - a_2$$

$$*\bar{y} = \frac{a_1y_1 + a_2y_2}{a_1 + a_2} \text{ but for cut-hole area } a_2 \text{ is taken - ve. Hence}$$

$$\bar{y} = \frac{a_1y_1 - a_2y_2}{a_1 - a_2}$$

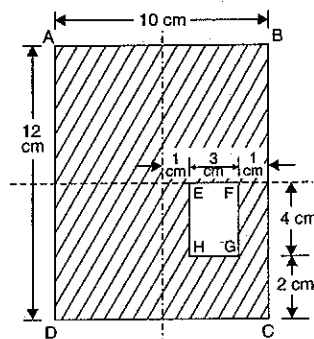

Fig. 5.6

$$= \frac{a_1y_1 - a_2y_2}{a_1 - a_2} \quad (- \text{ve sign is taken due to cut-out hole})$$

$$= \frac{120 \times 6 - 12 \times 4}{120 - 12} = \frac{720 - 48}{108} = 6.22 \text{ cm.}$$

To Find  $\bar{x}$ 

Let  $\bar{x} =$  Distance between the C.G. of the section with a cut hole from the left line  $AD$

$x_1 =$  Distance of the C.G. of the rectangle  $ABCD$  from the left line  $AD$

$$= \frac{10}{2} = 5 \text{ cm}$$

$x_2 =$  Distance of the C.G. of the cut-out hole from the left line  $AD$

$$= 5 + 1 + \frac{3}{2} = 7.5 \text{ cm.}$$

Using equation (5.1) and taking area ( $a_2$ ) of the cut hole as negative, we get

$$\bar{x} = \frac{a_1x_1 - a_2x_2}{a_1 - a_2} \quad (\because A = a_1 - a_2)$$

$$= \frac{120 \times 5 - 12 \times 7.5}{120 - 12} = \frac{600 - 90}{108} = \frac{510}{108} = 4.72 \text{ cm.}$$

Hence the C.G. of the section with a cut hole will be at a distance of 6.22 cm from bottom line  $DC$  and 4.72 cm from the line  $AD$ . **Ans.**

**Problem 5.5 (A).** Determine the co-ordinates  $X_C$  and  $Y_C$  of the centre of a  $100 \text{ mm}$  diameter circular hole cut in a thin plate so that this point will be the centroid of the remaining shaded area shown in Fig. 5.6 (a). (U.P. Tech. University, 2001-2002)

**Sol.** The given shaded area is equal to area of a thin rectangular plate of size  $200 \text{ mm} \times 150 \text{ mm}$  minus the area of a triangle of length  $100 \text{ mm}$  and height  $75 \text{ mm}$  minus the area of circular hole of dia.  $100 \text{ mm}$  as shown in Fig. 5.6 (b).

$$\text{Let } A_1 = \text{Area of rectangular plate}$$

$$= 200 \times 150 = 30000 \text{ mm}^2$$

$$A_2 = \text{Area of triangle}$$

$$= \frac{100 \times 75}{2} = 3750 \text{ mm}^2$$

$$A_3 = \text{Area of hole}$$

$$= \frac{\pi}{4} (100)^2 = 2500\pi \text{ mm}^2$$

The centre of hole is the centroid of the shaded area. Hence  $X_C$  and  $Y_C$  is the co-ordinates of the centre of the hole and also the co-ordinates of the centroid of the shaded area.

For area  $A_1$ ,

$$x_1 = \frac{200}{2} = 100 \text{ mm}, y_1 = \frac{150}{2} = 75 \text{ mm}$$

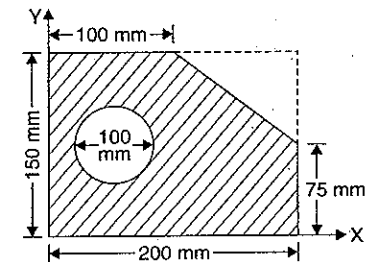

Fig. 5.6 (a)

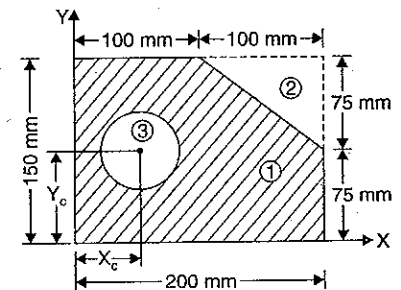

Fig. 5.6 (b)



For area  $A_2$ ,

$$x_2 = 100 + \frac{2}{3} \times 100 = 166.67,$$

$$y_2 = 75 + \frac{2}{3} \times 75 = 125 \text{ mm}$$

For area  $A_3$ ,  $x_3 = X_C$  and  $y_3 = Y_C$

Now using equation (5.1) and taking areas  $A_2$  and  $A_3$  as negative, we get

$$\bar{x} = X_C = \frac{A_1 x_1 - A_2 x_2 - A_3 x_3}{A_1 - A_2 - A_3} = \frac{30000 \times 100 - 3750 \times 166.67 - 2500\pi \times X_C}{(30000 - 3750 - 2500\pi)}$$

$$\text{or } X_C (30000 - 3750 - 2500\pi) = 30000 \times 100 - 3750 \times 166.67 - 2500\pi \times X_C$$

$$\text{or } X_C (30000 - 3750) - 2500\pi \times X_C = 30000 \times 100 - 3750 \times 166.67 - 2500\pi \times X_C$$

$$X_C (30000 - 3750) = 30000 \times 100 - 3750 \times 166.67$$

(Cancelling  $2500 \times \pi \times X_C$  on both sides)

$$\therefore 26250 X_C = 300000 - 625012.5 = 2374987.5$$

$$\therefore X_C = \frac{2374987.5}{26250} = 90.47 \text{ mm. Ans.}$$

Similarly,

$$\bar{y} = Y_C = \frac{A_1 y_1 - A_2 y_2 - A_3 y_3}{A_1 - A_2 - A_3}$$

$$= \frac{30000 \times 75 - 3750 \times 125 - 2500\pi \times Y_C}{(30000 - 3750 - 2500\pi)}$$

$$\text{or } Y_C (30000 - 3750 - 2500\pi) = 30000 \times 75 - 3750 \times 125 - 2500\pi \times Y_C$$

$$\text{or } Y_C (30000 - 3750) = 30000 \times 75 - 3750 \times 125$$

(Cancelling  $2500\pi \times Y_C$  on both sides)

$$\text{or } 26250 Y_C = 30000 \times 75 - 3750 \times 125$$

$$= 225000 - 468750 = 1781250$$

$$\therefore Y_C = \frac{1781250}{26250} = 67.85 \text{ mm. Ans.}$$

**Problem 5.5 (B).** A semi-circular area is removed from the trapezoid as shown in Fig. 5.6 (c). Determine the centroid of the remaining area.

(U.P. Tech. University, 2000-2001)

**Sol.** The given shaded area is equal to the area of a thin rectangular plate of size  $100 \text{ mm} \times (150 + 100) \text{ mm}$  plus the area of the triangle of length  $250 \text{ mm}$  and of height  $(150 - 100) = 50 \text{ mm}$  minus the area of semi-circular area of diameter  $100 \text{ mm}$  as shown in Fig. 5.6 (c).

$$\text{Let } A_1 = \text{Area of rectangular plate} \\ = 100 \times 250 = 25000 \text{ mm}^2$$

$$A_2 = \text{Area of semi-circle} = \frac{\pi r^2}{2} = \frac{\pi \times 50^2}{2} = 1250\pi \text{ mm}^2$$

$$A_3 = \text{Area of the triangle} = \frac{250 \times 50}{2} = 6250 \text{ mm}^2$$

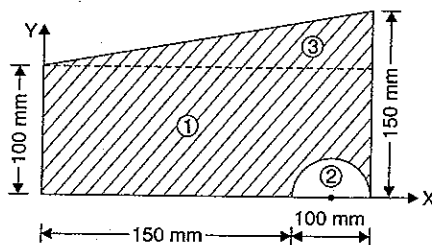

Fig. 5.6 (c)

$$x_1 = \text{Distance of C.G. of area } A_1 \text{ from } y\text{-axis} = \frac{250}{2} = 125 \text{ mm}$$

$$y_1 = \text{Distance of C.G. of area } A_1 \text{ from } x\text{-axis} = \frac{100}{2} = 50 \text{ mm}$$

$$x_2 = \text{Distance of C.G. of area } A_2 \text{ from } y\text{-axis} = 150 + \frac{100}{2} = 200 \text{ mm}$$

$$y_2 = \text{Distance of C.G. of area } A_2 \text{ from } x\text{-axis} = \frac{4r}{3\pi} = \frac{4 \times 50}{3\pi} = \frac{200}{3\pi}$$

$$x_3 = \text{Distance of C.G. of area } A_3 \text{ from } y\text{-axis} = 250 \times \frac{2}{3} = \frac{500}{3}$$

$$y_3 = \text{Distance of C.G. of area } A_3 \text{ from } x\text{-axis} = 100 + \frac{50}{3} = \frac{350}{3} \text{ mm}$$

$\bar{x}$ ,  $\bar{y}$  = Distance of C.G. of the shaded area from  $y$  and  $x$ -axis.

Now using equation (5.1) and taking area  $A_2$  as negative, we get

$$\bar{x} = \frac{A_1 x_1 - A_2 x_2 + A_3 x_3}{A_1 - A_2 + A_3}$$

$$= \frac{25000 \times 125 - 1250\pi \times 200 + 6250 \times \frac{500}{3}}{25000 - 1250\pi + 6250}$$

$$= \frac{3125000 - 785398 + 1041666}{27323} = 123.75 \text{ mm. Ans.}$$

Similarly,

$$\bar{y} = \frac{A_1 y_1 - A_2 y_2 + A_3 y_3}{A_1 - A_2 + A_3} = \frac{25000 \times 50 - 1250\pi \times \frac{200}{3\pi} + 6250 \times \frac{350}{3}}{27323}$$

$$= \frac{1250000 - 83333 + 729166}{27323} = 69.38 \text{ mm. Ans.}$$

$\therefore$  Centroid of the given section =  $(\bar{x}, \bar{y}) = (123.75 \text{ mm}, 69.38 \text{ mm})$ .

### 5.5.2. Problems of Finding Centroid or Centre of Gravity of Areas by Integration

**Method.**

**Problem 5.6.** Determine the co-ordinates of the C.G. of the area OAB shown in Fig. 5.7, if the curve OB represents the equation of a parabola, given by

$$y = kx^2$$

in which

$$OA = 6 \text{ units}$$

and

$$AB = 4 \text{ units.} \quad \dots(i)$$

**Sol.** The equation of parabola is  $y = kx^2$

First determine the value of constant  $k$ . The point B is lying on the curve and having co-ordinates

$$x = 6 \text{ and } y = 4$$

Substituting these values of equation (i), we get

$$4 = k \times 6^2 = 36k$$

$$\therefore k = \frac{4}{36} = \frac{1}{9}$$

Substituting the value of  $h$  in equation (i), we get

$$y = \frac{1}{9} x^2 \quad \dots(ii)$$

or  $x^2 = 9y$

or  $x = 3\sqrt{y} \quad \dots(iii)$

Consider a strip of height  $y$  and width  $dx$  as shown in Fig. 5.7. The area  $dA$  of the strip is given by

$$dA = y \times dx$$

The co-ordinates of the C.G. of this area  $dA$  are  $x$  and  $\frac{y}{2}$

$\therefore$  Distance of C.G. of area  $dA$  from  $y$ -axis =  $x$

and distance of C.G. of area  $dA$  from  $x$ -axis =  $\frac{y}{2}$

$\therefore x^* = x$  and  $y^* = \frac{y}{2}$

Let  $\bar{x}$  = Distance of C.G. of total area  $OAB$  from axis  $OY$

$\bar{y}$  = Distance of C.G. of total area  $OAB$  from axis  $OX$ .

Using equation (5.2 A), we get

$$\bar{x} = \frac{\int x^* dA}{\int dA} = \frac{\int_0^6 x \times y dx}{\int_0^6 y dx}$$

But  $y = \frac{x^2}{9}$  from equation (ii).

$$\bar{x} = \frac{\int_0^6 x \times \frac{x^2}{9} \times dx}{\int_0^6 \frac{x^2}{9} dx} = \frac{\frac{1}{9} \int_0^6 x^3 dx}{\frac{1}{9} \int_0^6 x^2 dx}$$

$$= \frac{\int_0^6 x^3 dx}{\int_0^6 x^2 dx} = \frac{\left[ \frac{x^4}{4} \right]_0^6}{\left[ \frac{x^3}{3} \right]_0^6} = \frac{\frac{1}{4} \times 6^4}{\frac{1}{3} \times 6^3}$$

$$= \frac{1}{4} \times \frac{3}{1} \times 6 = 4.5. \quad \text{Ans.}$$

Using equation (5.2 B), we get

$$\bar{y} = \frac{\int y^* dA}{\int dA}$$

where  $y^*$  = Distance of C.G. of area  $dA$  from  $x$ -axis

$$= \frac{y}{2} \quad (\text{here})$$

$$dA = y dx$$

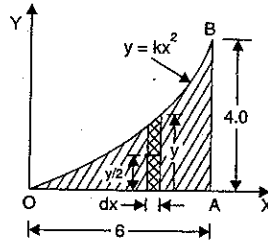

Fig. 5.7

$$(\because dA = y dx, x^* = x)$$

$$\begin{aligned} \therefore \int y^* dA &= \int \frac{y}{2} \times dA = \int_0^6 \frac{y}{2} \times y dx = \int_0^6 \frac{y^2}{2} dx \\ &= \frac{1}{2} \int_0^6 y^2 dx = \frac{1}{2} \int_0^6 \left( \frac{x^2}{9} \right)^2 dx \quad \left( \because y = \frac{x^2}{9} \right) \\ &= \frac{1}{2} \int_0^6 \frac{x^4}{81} dx = \frac{1}{2} \times \frac{1}{81} \int_0^6 x^4 dx = \frac{1}{2} \times \frac{1}{81} \left[ \frac{x^5}{5} \right]_0^6 \\ &= \frac{1}{2} \times \frac{1}{81} \times \frac{6^5}{5} = \frac{6^5}{810} \end{aligned}$$

$$\text{Also } \int dA = \int_0^6 y dx = \int_0^6 \frac{x^2}{9} dx = \frac{1}{9} \left[ \frac{x^3}{3} \right]_0^6 = \frac{1}{9} \times \frac{6^3}{3} = \frac{6^3}{27}$$

$$\begin{aligned} \therefore \bar{y} &= \frac{\int y^* dA}{\int dA} = \frac{\frac{6^5}{810}}{\frac{6^3}{27}} = \frac{27}{810} \times \frac{6^5}{6^3} \\ &= \frac{1}{30} \times 6^2 = \frac{36}{30} = \frac{6}{5}. \quad \text{Ans.} \end{aligned}$$

**Problem 5.7.** Determine the co-ordinates of the C.G.

of the shaded area between the parabola  $y = \frac{x^2}{4}$  and the straight line  $y = x$  as shown in Fig. 5.8.

**Sol.** The equations of parabola and straight line are

$$y = \frac{x^2}{4} \quad \dots(i)$$

$$y = x \quad \dots(ii)$$

The point A is lying on the straight line as well as on the given parabola. Hence both the above equations hold good for point A. Let the co-ordinates of point A are  $x, y$ .

Substituting the value of  $y$  from equation (ii) in equation (i), we get

$$x = \frac{x^2}{4} \quad \text{or} \quad 4 = \frac{x^2}{x} = x$$

Substituting the value of  $x = 4$ , in equation (ii),

$$y = 4$$

Hence the co-ordinates of point A are 4, 4.

Now divide the shaded area into large small areas each of height  $y$  and width  $dx$  as shown in Fig. 5.8. Then area  $dA$  of the strip is given by

$$dA = y dx = (y_1 - y_2) dx \quad \dots(iii)$$

where  $y_1$  = Co-ordinate of point D which lies on the straight line OA

$y_2$  = Co-ordinate of the point E which lies on the parabola OA.

The horizontal co-ordinates of the points D and E are same.

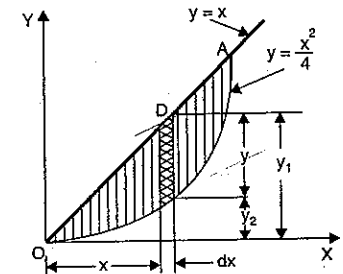

Fig. 5.8

The values of  $y_1$  and  $y_2$  can be obtained in terms of  $x$  from equations (ii) and (i),

$$y_1 = x \quad \text{and} \quad y_2 = \frac{x^2}{4}$$

Substituting these values in equation (iii),

$$dA = \left( x - \frac{x^2}{4} \right) dx \quad \dots(iv)$$

The distance of the C.G. for the area  $dA$  from  $y$ -axis is given by,

$$x^* = x$$

And the distance of the C.G. of the area  $dA$  from  $x$ -axis is given by,

$$y^* = y_2 + \frac{y}{2} = y_2 + \frac{y_1 - y_2}{2} \quad (\because y = y_1 - y_2)$$

$$= \frac{2y_2 + y_1 - y_2}{2} = \frac{y_1 + y_2}{2}$$

$$= \frac{x + \frac{x^2}{4}}{2} \quad \left( \because y_1 = x \text{ and } y_2 = \frac{x^2}{4} \right)$$

$$= \frac{1}{2} \left( x + \frac{x^2}{4} \right) \quad \dots(v)$$

Now let  $\bar{x}$  = Distance of C.G. of shaded area of Fig. 5.8 from  $y$ -axis

$\bar{y}$  = Distance of C.G. of shaded area of Fig. 5.8 from  $x$ -axis.

Now using equation (5.2 A),

$$\bar{x} = \frac{\int x^* dA}{\int dA} \quad \text{where } x^* = x$$

$$dA = \left( x - \frac{x^2}{4} \right) dx \quad [\text{See equation (iv)}]$$

$$\int x^* dA = \int_0^4 x \left( x - \frac{x^2}{4} \right) dx \quad (\because x \text{ varies from } 0 \text{ to } 4)$$

$$= \int_0^4 \left( x^2 - \frac{x^3}{4} \right) dx = \left[ \frac{x^3}{3} - \frac{x^4}{4 \times 4} \right]_0^4$$

$$= \frac{4^3}{3} - \frac{4^4}{4 \times 4} = \frac{64}{3} - 16$$

$$= \frac{64 - 48}{3} = \frac{16}{3}$$

$$\int dA = \int_0^4 \left( x - \frac{x^2}{4} \right) dx$$

$$= \left[ \frac{x^2}{2} - \frac{x^3}{3 \times 4} \right]_0^4 = \frac{4^2}{2} - \frac{4^3}{3 \times 4}$$

$$= \frac{16}{2} - \frac{16}{3} = \frac{48 - 32}{6} = \frac{16}{6} \quad \dots(vi)$$

and

$$\bar{x} = \frac{\int x^* dA}{\int dA} = \frac{\frac{16}{3}}{\frac{16}{6}} = \frac{16}{3} \times \frac{6}{16} = 2. \quad \text{Ans.}$$

Now using equation (5.2 B),  $\bar{y} = \frac{\int y^* dA}{\int dA}$

where

$$y^* = \frac{1}{2} \left[ x + \frac{x^2}{4} \right] \quad [\text{From equation (v)}]$$

$$dA = \left( x - \frac{x^2}{4} \right) dx$$

$$\int y^* dA = \int_0^4 \frac{1}{2} \left( x + \frac{x^2}{4} \right) \left( x - \frac{x^2}{4} \right) dx$$

$$= \frac{1}{2} \int_0^4 \left( x^2 - \frac{x^4}{16} \right) dx = \frac{1}{2} \left[ \frac{x^3}{3} - \frac{x^5}{5 \times 16} \right]_0^4$$

$$= \frac{1}{2} \left[ \frac{4^3}{3} - \frac{4^5}{5 \times 16} \right] = \frac{1}{2} \left[ \frac{64}{3} - \frac{64}{5} \right]$$

$$= \frac{64}{2} \left[ \frac{1}{3} - \frac{1}{5} \right] = 32 \left( \frac{5-3}{15} \right)$$

$$= 32 \times \frac{2}{15} = \frac{64}{15}$$

and

$$\int dA = \frac{16}{6} \quad [\text{From equation (vi)}]$$

$$\bar{y} = \frac{\int y^* dA}{\int dA} = \frac{\frac{64}{15}}{\frac{16}{6}} = \frac{64}{15} \times \frac{6}{16} = \frac{8}{5}. \quad \text{Ans.}$$

### 5.5.3. Problems of Finding Centroid or Centre of Gravity of Line-Segment by Integration Method

**Problem 5.8.** Determine the centre of gravity of a quadrant  $AB$  of the arc of a circle of radius  $R$  as shown in Fig. 5.9 (a).

**Sol.** The centre of gravity of the line  $AB$ , which is an arc of a circle radius  $R$ , is obtained by dividing the curved line  $AB$  into a large number of elements of length  $dL$  as shown in Fig. 5.9 (a).

The equation of curve  $AB$  is the equation of circle of radius  $R$ .

$\therefore$  The equation of curve  $AB$  is given by

$$x^2 + y^2 = R^2$$

Differentiating the above equation,

$$2x dx + 2y dy = 0 \quad [\because R \text{ is constant}]$$

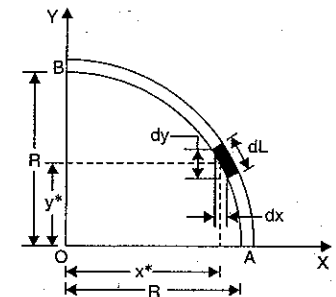

Fig. 5.9 (a)

or  $2y \, dy = -2x \, dx$   
 or  $dy = \frac{-2x \, dx}{2y} = \frac{-x \, dx}{y}$  ... (i)

Consider an element of length  $dL$  as shown in Fig. 5.9 (a). The C.G. of the length  $dL$  is at a distance  $x^*$  from  $y$ -axis and  $y^*$  from  $x$ -axis.

Now using equation (5.2 D) for  $\bar{y}$ , we get

$$\bar{y} = \frac{\int y^* \, dL}{\int dL} \quad \dots (ii)$$

Let us express  $dL$  in terms of  $dx$  and  $dy$ .

But  $dL = \sqrt{dx^2 + dy^2}$

$$= \sqrt{dx^2 + \left(\frac{-x \, dx}{y}\right)^2} \quad \left(\because \text{From (i), } dy = \frac{-x \, dx}{y}\right)$$

$$= \sqrt{dx^2 + \frac{x^2}{y^2} dx^2}$$

$$= dx \sqrt{1 + \frac{x^2}{y^2}} = dx \sqrt{\frac{y^2 + x^2}{y^2}}$$

$$= dx \sqrt{\frac{R^2}{y^2}} \quad (\because x^2 + y^2 = R^2)$$

$$= \frac{R}{y} \cdot dx.$$

Substituting the value of  $dL$  in equation (ii),

$$\bar{y} = \frac{\int y^* \times \frac{R}{y} \cdot dx}{\int \frac{R}{y} \cdot dx} = \frac{\int y \times \frac{R}{y} \, dx}{\int dL} \quad (\because y^* = y)$$

$$= \frac{\int R \, dx}{\int dL} = \frac{R \int_0^R dx}{\int dL} = \frac{R \left[ x \right]_0^R}{\left( \frac{2\pi R}{4} \right)}$$

( $\because \int dL$  is total length of arc of one quadrant of a circle)

$$= \frac{R \times R}{\frac{2\pi R}{4}} = \frac{2R}{\pi} \quad \text{Ans.}$$

Similarly, the value of  $\bar{x}$  can be calculated. Due to symmetry this value will also be equal to  $\frac{2R}{\pi}$ .

$$\bar{x} = \bar{y} = \frac{2R}{\pi} \quad \text{Ans.}$$

### 2nd Method

Here  $dL = R \, d\theta$   
 $y^* = R \sin \theta$   
 $x^* = R \cos \theta$

Now  $\bar{y} = \frac{\int y^* \, dL}{\int dL} = \frac{\int_0^{\pi/2} (R \sin \theta) \times (R \, d\theta)}{\int_0^{\pi/2} R \, d\theta}$

$$= \frac{\int_0^{\pi/2} R^2 \sin \theta \, d\theta}{\int_0^{\pi/2} R \, d\theta} = \frac{R^2 \int_0^{\pi/2} \sin \theta \, d\theta}{R \int_0^{\pi/2} d\theta}$$

$$= \frac{R^2 \left[ -\cos \theta \right]_0^{\pi/2} - R \left[ \cos \left( \frac{\pi}{2} \right) - \cos 0 \right]}{R \left[ \theta \right]_0^{\pi/2} - \left[ \frac{\pi}{2} - 0 \right]}$$

$$= \frac{-R[0 - 1]}{\frac{\pi}{2}} = \frac{2R}{\pi} \quad \text{Ans.}$$

Similarly,

$$\bar{x} = \frac{\int x^* \, dL}{\int dL} = \frac{\int_0^{\pi/2} (R \cos \theta) \times (R \, d\theta)}{\int_0^{\pi/2} R \, d\theta} = \frac{R^2 \int_0^{\pi/2} \cos \theta \, d\theta}{R \int_0^{\pi/2} d\theta}$$

$$= \frac{R \left[ \sin \theta \right]_0^{\pi/2}}{R \left[ \theta \right]_0^{\pi/2}} = \frac{R[\sin 90^\circ - \sin 0^\circ]}{\left( \frac{\pi}{2} - 0 \right)} = \frac{R}{\left( \frac{\pi}{2} \right)} = \frac{2R}{\pi} \quad \text{Ans.}$$

**Problem 5.9.** Determine the centre of gravity of the area of the circular sector  $OAB$  of radius  $R$  and central angle  $\alpha$  as shown in Fig. 5.10.

**Sol.** The given area is symmetrical about  $x$ -axis. Hence the C.G. of the area will lie on  $x$ -axis. This means  $\bar{y} = 0$ . To find  $\bar{x}$ , the moment of small areas are to be taken along  $y$ -axis. Divide the area  $OAB$  into a large number of triangular elements each of altitude  $R$  and base  $R \, d\theta$  as shown in Fig. 5.10. Such triangular element is shown by  $OCD$  in which altitude  $OC = R$  and base  $CD = R \, d\theta$ . The area  $dA$  of this triangular element is given by,

$$dA = \frac{OC \times CD}{2} = \frac{R \times R \, d\theta}{2}$$

$$= \frac{R^2 \, d\theta}{2}$$

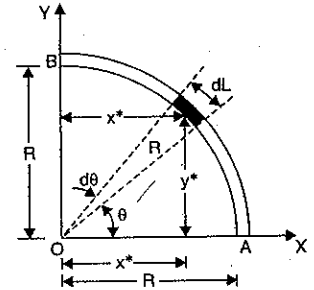

Fig. 5.9 (b)

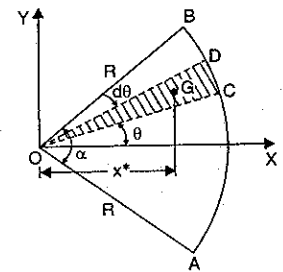

Fig. 5.10

The C.G. of this triangular element is at  $G$

where  $OG = \frac{2}{3} \times OC = \frac{2}{3} \times R$

The distance of C.G. of area  $dA$  from  $y$ -axis is given by,

$$x^* = OG \times \cos \theta = \frac{2}{3} R \times \cos \theta$$

Now using equation (5.2 A),

$$\begin{aligned} \bar{x} &= \frac{\int x^* dA}{\int dA} = \frac{2 \int_0^{\alpha/2} \left( \frac{2}{3} R \cos \theta \right) \left( \frac{R^2 d\theta}{2} \right)}{2 \int_0^{\alpha/2} \frac{R^2}{2} d\theta} \\ &= \frac{\frac{R^3}{3} \int_0^{\alpha/2} \cos \theta d\theta}{\frac{R^2}{2} \int_0^{\alpha/2} d\theta} = \frac{2R \left[ \sin \theta \right]_0^{\alpha/2}}{\left[ \theta \right]_0^{\alpha/2}} \\ &= \frac{2R \sin \left( \frac{\alpha}{2} \right)}{\left( \frac{\alpha}{2} \right)} = \frac{4R}{3\alpha} \sin \left( \frac{\alpha}{2} \right). \text{ Ans.} \end{aligned}$$

The area  $OAB$  is symmetrical about the  $x$ -axis, hence

$$\bar{y} = 0. \text{ Ans.}$$

For a semi-circle,  $\alpha = \pi = 180^\circ$ , hence

$$\begin{aligned} \bar{x} &= \frac{4R}{3\pi} \sin \left( \frac{\pi}{2} \right) \\ &= \frac{4R}{3 \times \pi} \sin \left( \frac{180}{2} \right) = \frac{4R}{3\pi}. \text{ Ans.} \end{aligned}$$

**Problem 5.10.** Determine the centre of gravity of a semi-circle of radius  $R$  as shown in Fig. 5.10 (a).

**Sol.** This problem can also be solved by the method given in problem 5.9. The following other methods can also be used. Due to symmetry,  $\bar{x} = 0$ . The area  $AOB$  is symmetrical about the  $Y$ -axis, hence  $\bar{x} = 0$ . The value of  $\bar{y}$  is obtained by taking the moments of small areas and total area about  $x$ -axis.

**1. Considering the strip parallel to  $Y$ -axis**

Area of strip,  $dA = y \cdot dx$

The distance of the C.G. of the area  $dA$  from

$x$ -axis is equal to  $\frac{y}{2}$

Moment of area  $dA$  about  $x$ -axis

$$= dA \cdot \frac{y}{2}$$

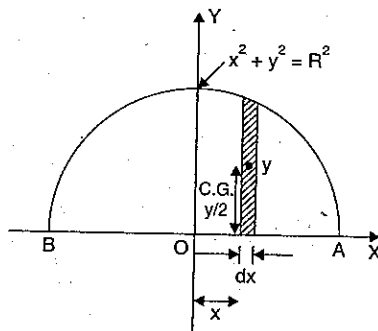

Fig. 5.10 (a)

$$= \frac{y}{2} \cdot dA$$

$$= \frac{y}{2} \cdot y dx$$

$$(\because dA = y \cdot dx)$$

$$= \frac{y^2}{2} \cdot dx$$

Moment of total area  $A$  about  $x$ -axis is obtained by integrating the above equation.

$\therefore$  Moment of total area  $A$  about  $x$ -axis

$$= \int \frac{y^2}{2} \cdot dx$$

$$= \int_{-R}^R \frac{y^2}{2} dx$$

$$(\because x \text{ varies from } -R \text{ to } R)$$

But equation of semi-circle is

$$x^2 + y^2 = R^2 \quad \text{or} \quad y^2 = R^2 - x^2$$

Substituting this value of  $y^2$  in the above equation, we get

Moment of total area  $A$  about  $x$ -axis

$$= \int_{-R}^R \frac{(R^2 - x^2)}{2} dx$$

$$= \frac{1}{2} \left[ R^2 \cdot x - \frac{x^3}{3} \right]_{-R}^R$$

$$= \frac{1}{2} \left[ \left( R^2 \cdot R - \frac{R^3}{3} \right) - \left( R^2 \cdot (-R) - \frac{(-R)^3}{3} \right) \right]$$

$$= \frac{1}{2} \left[ \left( R^3 - \frac{R^3}{3} \right) - \left( -R^3 - \frac{(-R^3)}{3} \right) \right]$$

$$= \frac{1}{2} \left[ \frac{2R^3}{3} - \left( -R^3 + \frac{R^3}{3} \right) \right] = \frac{1}{2} \left[ \frac{2R^3}{3} - \left( -\frac{2R^3}{3} \right) \right]$$

$$= \frac{1}{2} \left[ \frac{2R^3}{3} + \frac{2R^3}{3} \right] = \frac{1}{2} \times \frac{4R^3}{3} = \frac{2R^3}{3} \quad \dots(i)$$

Let  $\bar{y}$  = Distance of C.G. of the total area of semi-circle from  $x$ -axis.

The total area of semi-circle is also equal to  $\frac{\pi R^2}{2}$

$\therefore$  Moment of this total area about  $x$ -axis

$$= \bar{y} \times \frac{\pi R^2}{2} \quad \dots(ii)$$

Equating the two values given by equations (i) and (ii), we get

$$\bar{y} \times \frac{\pi R^2}{2} = \frac{2R^3}{3}$$

$$\bar{y} = \frac{2R^3}{3} \times \frac{2}{\pi R^2} = \frac{4R}{3\pi} \quad \text{Ans.}$$

Hence the location of C.G. of semi-circle is  $(0, \frac{4R}{3\pi})$ . Ans.

### 2. Considering the strip parallel to x-axis

Area of strip,  $dA = 2x \cdot dy$

The distance of the C.G. of this area from x-axis is  $y$

$\therefore$  Moment of this area about x-axis

$$= y \cdot dA$$

$$= y \cdot 2x dy$$

$$= 2xy dy \quad \dots(i)$$

But, we know  $x^2 + y^2 = R^2$

$$\therefore x^2 = R^2 - y^2$$

$$x = \sqrt{R^2 - y^2}$$

Substituting the above value of  $x$  in equation (i), we get

Moment of area  $dA$  about x-axis,

$$= 2\sqrt{R^2 - y^2} \cdot y \cdot dy$$

Moment of total area  $A$  about x-axis will be obtained by integrating the above equation from  $O$  to  $R$ .

$\therefore$  Moment of area  $A$  about x-axis

$$= \int_0^R 2\sqrt{R^2 - y^2} \cdot y \cdot dy \quad (\because y \text{ varies from } O \text{ to } R)$$

$$= - \int_0^R \sqrt{R^2 - y^2} \cdot (-2y) dy = - \left[ \frac{(R^2 - y^2)^{3/2}}{3/2} \right]_0^R$$

$$= - \frac{2}{3} [0 - R^2] = \frac{2R^3}{3} \quad \dots(ii)$$

Also the moment of total area  $A$  about x-axis =  $A \times \bar{y}$

where  $A = \text{Total area of semi-circle} = \frac{\pi R^2}{2}$

$\bar{y} = \text{Distance of C.G. of area } A \text{ from x-axis}$

$$\therefore \text{Moment of total area } A \text{ about x-axis} = \frac{\pi R^2}{2} \times \bar{y} \quad \dots(iii)$$

Equating the two values given by equations (ii) and (iii),

$$\frac{\pi R^2}{2} \times \bar{y} = \frac{2R^3}{3}$$

$$\bar{y} = \frac{2R^3}{3} \times \frac{2}{\pi R^2} = \frac{4R}{3\pi} \quad \text{Ans.}$$

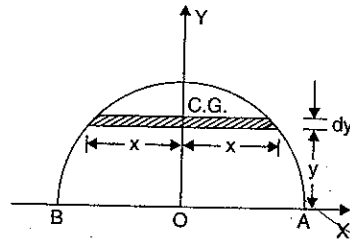

Fig. 5.10 (b)

**Problem 5.11.** To determine the centre of gravity of the area shown in Fig. 5.10 (c) given by

$$\frac{x^2}{a^2} + \frac{y^2}{b^2} = 1.$$

**Sol.** Consider a small strip of thickness  $dx$  parallel to y-axis at a distance of  $x$  from the y-axis.

Area of the strip,  $dA = y \cdot dx$

The C.G. of area  $dA$  is at a distance  $\frac{y}{2}$  from x-axis.

Moment of the area  $dA$  about x-axis

$$= \frac{y}{2} \cdot dA$$

$$= \frac{y}{2} \cdot y dx \quad (\because dA = y \cdot dx)$$

$$= \frac{y^2}{2} \cdot dx$$

$\therefore$  Moment of the total area about x-axis

$$= \int_0^a \frac{y^2}{2} \cdot dx \quad (\because x \text{ varies from } O \text{ to } a) \quad \dots(i)$$

Let us substitute the value of  $y^2$  in terms of  $x$ .

The given equation is  $\frac{x^2}{a^2} + \frac{y^2}{b^2} = 1$

$$\text{or} \quad \frac{y^2}{b^2} = 1 - \frac{x^2}{a^2} = \frac{a^2 - x^2}{a^2}$$

$$\text{or} \quad y^2 = \frac{b^2}{a^2} (a^2 - x^2) \quad \dots(ii)$$

Substituting the value of  $y^2$  in equation (i), we get

Moment of total area about x-axis

$$\begin{aligned} &= \frac{1}{2} \int_0^a \frac{b^2}{a^2} (a^2 - x^2) dx = \frac{b^2}{2a^2} \left[ a^2 x - \frac{x^3}{3} \right]_0^a \\ &= \frac{b^2}{2a^2} \left[ a^3 - \frac{a^3}{3} \right] = \frac{b^2}{2a^2} \times \frac{2a^3}{3} = \frac{ab^2}{3} \quad \dots(iii) \end{aligned}$$

The total area  $A$  of the given figure is given by

$$A = \int dA = \int y \cdot dx \quad \dots(iv)$$

$$\text{From equation (ii),} \quad y = \left[ \frac{b^2}{a^2} (a^2 - x^2) \right]^{1/2} = \frac{b}{a} (a^2 - x^2)^{1/2} \quad \dots(v)$$

Now equation (iv) is,  $A = \int_0^a \frac{b}{a} (a^2 - x^2)^{1/2} \cdot dx$

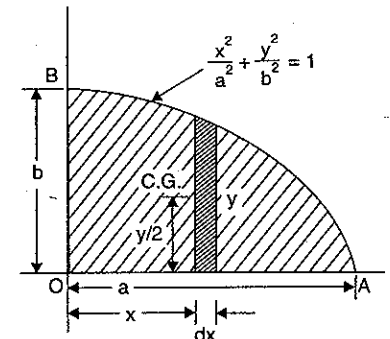

Fig. 5.10 (c)

$$= \frac{b}{a} \left[ \int_0^a (a^2 - x^2)^{1/2} \cdot dx \right]^* = \frac{b}{a} \left[ \frac{\pi a^2}{4} \right]^*$$

$$= \frac{\pi \cdot ab}{4} \quad \left( \because \int_0^a \sqrt{a^2 - x^2} dx = \frac{\pi a^2}{4} \right) \dots (vi)$$

Let  $\bar{y}$  = the distance of C.G. of the total area  $A$  from  $x$ -axis.

Then moment of total area  $A$  about  $x$ -axis

$$= A \times \bar{y}$$

$$= \frac{\pi ab}{4} \cdot \bar{y} \quad \dots (vii)$$

The equations (iii) and (vii) give the moment of total area about  $x$ -axis. Hence equating these equations, we get

$$\frac{\pi ab}{4} \cdot \bar{y} = \frac{ab^2}{3}$$

$$\therefore \bar{y} = \frac{ab^2}{3} \cdot \frac{4}{\pi ab} = \frac{4b}{3\pi} \quad \text{Ans.}$$

To find  $\bar{x}$ , take the moment of small area  $dA$  about  $y$ -axis.

The C.G. of area  $dA$  is at a distance of  $x$  from  $y$ -axis.

$\therefore$  Moment of area  $dA$  about  $y$ -axis =  $x \cdot dA$

$$= x \cdot y \cdot dx \quad (\because dA = y dx)$$

Moment of total area  $A$  about  $y$ -axis is obtained by integration

Now moment of total area  $A$  about  $y$ -axis

$$= \int_0^a x \cdot y \cdot dx \quad (\because x \text{ varies from } O \text{ to } a)$$

$$= \int_0^a x \cdot \frac{b}{a} (a^2 - x^2)^{1/2} \cdot dx \quad \left[ \because y = \frac{b}{a} (a^2 - x^2)^{1/2} \text{ from equation (v)} \right]$$

$$= \frac{b}{a} \int_0^a x \cdot (a^2 - x^2)^{1/2} dx = \frac{b}{a} \int_0^a \frac{(-2)}{(-2)} \cdot x (a^2 - x^2)^{1/2} \cdot dx$$

$$= \frac{b}{-2a} \left[ \frac{(a^2 - x^2)^{3/2}}{3/2} \right]_0^a = \frac{-b}{3a} [0 - a^3] = \frac{ba^2}{3} \quad \dots (viii)$$

Also the moment of total area  $A$  about  $y$ -axis

$$= A \times \bar{x} \quad \dots (ix)$$

where  $\bar{x}$  = Distance of C.G. of total area  $A$  from  $y$ -axis.

Equating the two values given by equations (viii) and (ix),

$$A \times \bar{x} = \frac{ba^2}{3}$$

\*Please refer some standard TextBook of Mathematics.

$$\int_0^a \sqrt{a^2 - x^2} dx = \left[ \frac{1}{2} x \sqrt{a^2 - x^2} + \frac{1}{2} a^2 \sin^{-1} \frac{x}{a} \right]_0^a = \left[ 0 + \frac{1}{2} a^2 \sin^{-1} (1) \right]$$

$$= \frac{1}{2} a^2 \left( \frac{\pi}{2} \right) = \frac{\pi a^2}{4}$$

$$\therefore \bar{x} = \frac{ba^2}{3A} = \frac{ba^2}{3 \times \frac{\pi ab}{4}}$$

$$= \frac{4a}{3\pi} \quad \text{Ans.}$$

The co-ordinates of the C.G. of given area are

$$\bar{x} = \frac{4a}{3\pi} \quad \text{and} \quad \bar{y} = \frac{4b}{3\pi}$$

$$\left[ \because A = \frac{\pi ab}{4} \text{ see equation (vi)} \right]$$

**5.5.4. Centroid of Volume.** Centroid of volume is the point at which the total volume of a body is assumed to be concentrated. The volume is having three dimensions i.e., length, width and thickness. Hence volume is measured in  $[\text{length}]^3$ . The centroid [i.e., or centre of gravity] of a volume is obtained by dividing the given volume into a large number of small volumes as shown in Fig. 5.10 (d). Similar method was used for finding the centroid of an area in which case the given area was divided into large number of small areas. The centroid of the volume is hence obtained by replacing  $dA$  by  $dv$  in equations (5.2A) and (5.2B).

Then these equations becomes as

$$\bar{x} = \frac{\int x^* dv}{\int dv} \quad \dots (5.3 A)$$

and

$$\bar{y} = \frac{\int y^* dv}{\int dv} \quad \dots (5.3 B)$$

As volume is having three dimensions, hence third equation is written as

$$\bar{z} = \frac{\int z^* dv}{\int dv} \quad \dots (5.3 C)$$

where  $x^*$  = Distance of C.G. of small volume  $dv$  from  $y$ - $z$  plane (i.e., from axis  $oy$ )

$y^*$  = Distance of C.G. of small volume  $dv$  from  $x$ - $z$  plane (i.e., from axis  $ox$ )

$z^*$  = Distance of C.G. of small volume  $dv$  from  $x$ - $y$  plane

and  $\bar{x}$ ,  $\bar{y}$ ,  $\bar{z}$  = Location of centroid of total volume.

**Note.** If a body has a plane of symmetry, the centre of gravity lies in that plane. If it has two planes of symmetry, the line of intersection of the two planes gives the position of centre of gravity. If it has three planes of symmetry, the point of intersection of the three planes gives the position of centre of gravity.

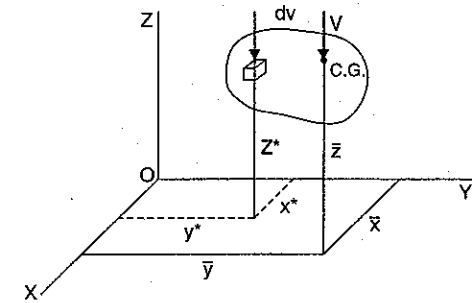

Fig. 5.10 (d)

**Problem 5.12.** A right circular cone of radius  $R$  at the base and of height  $h$  is placed as shown in Fig. 5.10 (e). Find the location of the centroid of the volume of the cone.

**Sol. Given :**

Radius of cone =  $R$

Height of cone =  $h$

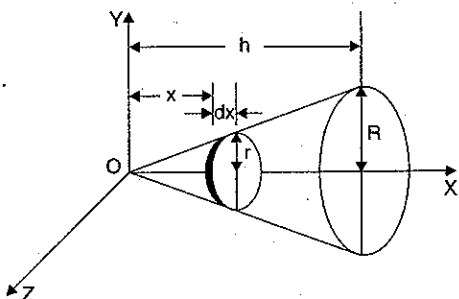

Fig. 5.10 (e)

In the Fig. 5.10 (e), the axis of the cone is along  $x$ -axis. The centroid will be at the  $x$ -axis. Hence,  $\bar{y} = 0$  and  $\bar{z} = 0$ .

To find  $\bar{x}$ , consider a small volume  $dv$ . For this, take a thin circular plate at a distance  $x$  from  $O$ . Let the thickness of the plate is  $dx$  as shown in figure and radius of the plate is  $r$ . The centroid of the plate is at a distance ' $x$ ' from  $O$ . Hence  $x^* = x$ .

Now volume of the thin plate,

$$dv = \pi r^2 \times dx \quad \dots(i)$$

Let us find the value of  $r$  in terms of  $x$ .

From similar triangles, we get

$$\frac{R}{r} = \frac{h}{x}$$

or

$$r = \frac{R \times x}{h}$$

Substituting the value of  $r$  in equation (i), we get

$$dv = \pi \left( \frac{R \times x}{h} \right)^2 dx \quad \dots(ii)$$

Now  $\bar{x}$  is given by equation (5.3A) as

$$\begin{aligned} \bar{x} &= \frac{\int x^* dv}{\int dv} = \frac{\int x dv}{\int dv} \quad [\because \text{Here } x^* = x] \\ &= \frac{\int x \cdot \pi \left( \frac{R \times x}{h} \right)^2 \cdot dx}{\int \pi \left( \frac{R \times x}{h} \right)^2 dx} \quad \left[ \because dv = \pi \left( \frac{R \times x}{h} \right)^2 dx \text{ from equation (ii)} \right] \end{aligned}$$

$$\begin{aligned} &= \frac{\pi \times R^2}{h^2} \int_0^h x^3 dx \\ &= \frac{\pi \times R^2}{h^2} \int_0^h x^2 dx \end{aligned}$$

[ $\because$  Limits of integration are w.r.t.  $x$ . And  $x$  varies from 0 to  $h$ ]

$$= \left[ \frac{\left( \frac{x^4}{4} \right)}{\frac{x^3}{3}} \right]_0^h = \frac{3h}{4} \quad \text{Ans.}$$

**Problem 5.13.** A hemisphere of radius  $R$  is placed as shown in Fig. 5.10 (f). The axis of symmetry is along  $z$ -axis. Find the centroid of the hemisphere.

**Sol.** The hemisphere is placed as shown in Fig. 5.10 (f). The axis of symmetry is taken as  $Z$ -axis. The centroid will be at the  $Z$ -axis. Hence  $\bar{x} = 0$  and  $\bar{y} = 0$ .

Radius of hemisphere =  $R$ .

To find  $\bar{z}$ , consider a small volume  $dv$  of the hemisphere. For this, take a thin circular plate at a height  $z$  and thickness  $dz$ . Let ' $y$ ' is the radius of this plate.

Then  $dv = \text{Area of section} \times \text{thickness}$   
 $= \pi y^2 \times dz \quad \dots(i)$

[ $\because$  Area of any section for sphere or hemisphere =  $\pi r^2$ , Here  $r = y$ ]

The centre of gravity of the small volume is at a distance  $z$  from  $O$ .

Let us now, find the value of  $y$  in terms of  $z$ .

From Fig. 5.10 (f), we have

$$R^2 = z^2 + y^2$$

or

$$y^2 = R^2 - z^2$$

Substituting the value of  $y^2$  in equation (i), we get

$$dv = \pi [R^2 - z^2] \times dz \quad \dots(ii)$$

As in this case, the axis of symmetry is  $Z$ -axis. Hence  $\bar{x}$  and  $\bar{y}$  are zero. The distance of the centroid from  $x$ - $y$  plane is given by equation (5.3C) as

$$\bar{z} = \frac{\int z^* dv}{\int dv}$$

where  $z^* =$  Distance of centroid of the small volume  $dv$  from  $x$ - $y$  plane.  
 $= z$  [In the present case]

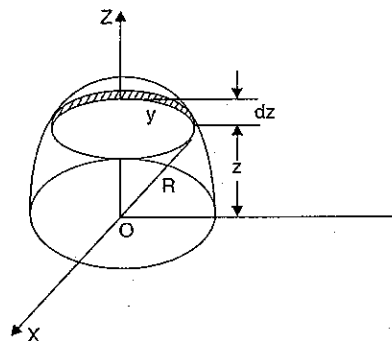

Fig. 5.10 (f)



$$\bar{z} = \frac{\int z \, dv}{\int dv}$$

$$= \frac{\int z \times \pi(R^2 - z^2) \, dz}{\int \pi(R^2 - z^2) \, dz} \quad [\because \text{From equation (ii), } dv = \pi(R^2 - z^2) \times dz]$$

$$= \frac{\int_0^R \pi(R^2 z - z^3) \, dz}{\int_0^R \pi(R^2 - z^2) \, dz}$$

[The limits of integration are according to  $dz$ . Here  $z$  varies from  $O$  to  $R$ ]

$$= \frac{\pi \left[ \frac{R^2 z^2}{2} - \frac{z^4}{4} \right]_0^R}{\pi \left[ R^2 z - \frac{z^3}{3} \right]_0^R} = \frac{\left[ \frac{R^2 \times R^2}{2} - \frac{R^4}{4} \right]}{\left[ R^2 \times R - \frac{R^3}{3} \right]} = \frac{\left( \frac{R^4}{4} \right)}{\frac{2}{3} R^3} = \frac{3}{8} R. \text{ Ans.}$$

**5.6. AREA MOMENT OF INERTIA**

Consider a thin lamina of area  $A$  as shown in Fig. 5.11.

Let  $x$  = Distance of the C.G. of area  $A$  from the axis  $OY$ .

$y$  = Distance of the C.G. of area  $A$  from the axis  $OX$ .

Then moment of area about the axis  $OY$

= Area  $\times$  perpendicular distance of C.G. of area from axis  $OY$

$$= Ax \quad \dots(5.3D)$$

Equation (5.3D) is known as *first moment of area* about the axis  $OY$ . This first moment of area is used to determine the centre of gravity of the area.

If the moment of area given by equation (5.3D) is again multiplied by the perpendicular distance between the C.G. of the area and axis  $OY$  (i.e., distance  $x$ ), then the quantity  $(Ax) \cdot x = Ax^2$  is known as moment of the moment of area or *second moment of area* or area moment of inertia about the axis  $OY$ . This second moment of area is used in the study of mechanics of fluids and mechanics of solids.

Similarly, the moment of area (or first moment of area) about the axis  $OX = Ay$ .

And second moment of area (or area moment of inertia) about the axis  $OX = (Ay) \cdot y = Ay^2$ .

If, instead of area, the mass ( $m$ ) of the body is taken into consideration then the second moment is known as second moment of mass. This second moment of mass is also known as mass moment of inertia.

Hence moment of inertia when mass is taken into consideration about the axis  $OY = mx^2$  and about the axis  $OX = my^2$ .

Hence the product of the area (or mass) and the square of the distance of the centre of gravity of the area (or mass) from an axis is known as *moment of inertia of the area (or mass) about that axis*. Moment of inertia is represented by  $I$ . Hence moment of inertia about the axis  $OX$  is represented by  $I_{xx}$  whereas about the axis  $OY$  by  $I_{yy}$ .

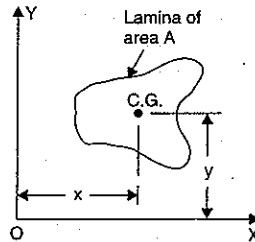

Fig. 5.11

The product of the area (or mass) and the square of the distance of the centre of gravity of the area (or mass) from an axis perpendicular to the plane of the area is known as polar moment of inertia and is represented by  $J$ .

Consider a plane area which is split up into small areas  $a_1, a_2, a_3, \dots$  etc. Let the C.G. of the small areas from a given axis be at a distance of  $r_1, r_2, r_3, \dots$  etc. as shown in Fig. 5.12.

Then the moment of inertia of the plane area about the given axis is given by

$$I = a_1 r_1^2 + a_2 r_2^2 + a_3 r_3^2 + \dots \quad \dots(5.4)$$

or

$$I = \Sigma ar^2. \quad \dots(5.5)$$

**5.7. RADIUS OF GYRATION**

Radius of gyration of a body (or a given lamina) about an axis is a distance such that its square multiplied by the area gives moment of inertia of the area about the given axis.

For the Fig. 5.12, the moment of inertia about the given axis is given by equation (5.4) as

$$I = a_1 r_1^2 + a_2 r_2^2 + a_3 r_3^2 + \dots \quad \dots(i)$$

Let the whole mass (or area) of the body is concentrated at a distance  $k$  from the axis of reference, then the moment of inertia of the whole area about the given axis will be equal to  $Ak^2$ .

If  $Ak^2 = I$ , then  $k$  is known as radius of gyration about the given axis.

$$k = \sqrt{\frac{I}{A}} \quad \dots(5.6)$$

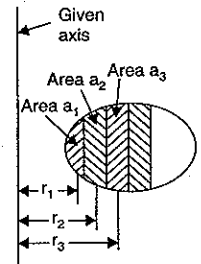

Fig. 5.12

**5.8. THEOREM OF THE PERPENDICULAR AXIS**

Theorem of the perpendicular axis states that if  $I_{xx}$  and  $I_{yy}$  be the moment of inertia of a plane section about two mutually perpendicular axis  $X-X$  and  $Y-Y$  in the plane of the section, then the moment of inertia of the section  $I_{zz}$  about the axis  $Z-Z$ , perpendicular to the plane and passing through the intersection of  $X-X$  and  $Y-Y$  is given by

$$I_{zz} = I_{xx} + I_{yy}$$

The moment of inertia  $I_{zz}$  is also known as **polar moment of inertia**.

**Proof.** A plane section of area  $A$  and lying in plane  $x-y$  is shown in Fig. 5.13. Let  $OX$  and  $OY$  be the two mutually perpendicular axes, and  $OZ$  be the perpendicular axis. Consider a small area  $dA$ .

Let  $x$  = Distance of  $dA$  from the axis  $OY$

$y$  = Distance of  $dA$  from axis  $OX$

$r$  = Distance of  $dA$  from axis  $OZ$

$$\text{Then } r^2 = x^2 + y^2.$$

Now moment of inertia of  $dA$  about  $x$ -axis

$$= dA \times (\text{Distance of } dA \text{ from } x\text{-axis})^2$$

$$= dA \times y^2.$$

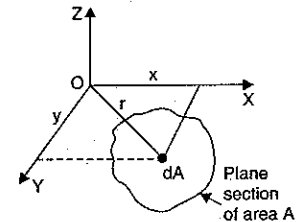

Fig. 5.13

∴ Moment of inertia of total area A about x-axis,  $I_{XX} = \Sigma dAy^2$ .  
 Similarly, moment of inertia of total area A about y-axis,  $I_{YY} = \Sigma dAx^2$   
 and moment of inertia of total area A about z-axis,  $I_{ZZ} = \Sigma dAr^2$   
 $= \Sigma dA [x^2 + y^2]$  ( $\because r^2 = x^2 + y^2$ )  
 $= \Sigma dA x^2 + \Sigma dA y^2$   
 $= I_{YY} + I_{XX}$   
 or  $I_{ZZ} = I_{XX} + I_{YY}$  ... (5.7)

The above equation shows that the moment of inertia of an area about an axis at origin normal to x, y plane is the sum of moments of inertia about the corresponding x and y-axis.  
 In equation (5.7),  $I_{ZZ}$  is known as **Polar Moment of Inertia**.

**5.9. THEOREM OF PARALLEL AXIS**

It states that if the moment of inertia of a plane area about an axis in the plane of area through the C.G. of the plane area be represented by  $I_G$ , then the moment of the inertia of the given plane area about a parallel axis AB in the plane of area at a distance h from the C.G. of the area is given by

$$I_{AB} = I_G + Ah^2.$$

where  $I_{AB}$  = Moment of inertia of the given area about AB  
 $I_G$  = Moment of inertia of the given area about C.G.  
 A = Area of the section  
 h = Distance between the C.G. of the section and the axis AB.

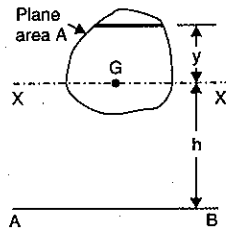

Fig. 5.14

**Proof.** A lamina of plane area A is shown in Fig. 5.14.  
 Let X-X = The axis in the plane of area A and passing through the C.G. of the area.  
 AB = The axis in the plane of area A and parallel to axis X-X.  
 h = Distance between AB and X-X.

Consider a strip parallel to X-X axis at a distance y from the X-X axis.  
 Let the area of the strip = dA

Moment of inertia of area dA about X-X axis =  $dAy^2$ .  
 ∴ Moment of inertia of the total area about X-X axis,  
 $I_{XX}$  or  $I_G = \Sigma dAy^2$  ... (i)

Moment of inertia of the area dA about AB  
 $= dA(h + y)^2$   
 $= dA[h^2 + y^2 + 2hy]$ .

∴ Moment of inertia of the total area A about AB,  
 $I_{AB} = \Sigma dA[h^2 + y^2 + 2hy]$   
 $= \Sigma dAh^2 + \Sigma dAy^2 + \Sigma dA 2hy$ .

As h or  $h^2$  is constant and hence they can be taken outside the summation sign. Hence the above equation becomes

$$I_{AB} = h^2 \Sigma dA + \Sigma dAy^2 + 2h \Sigma dAy.$$

But  $\Sigma dA = A$ . Also from equation (i),  $\Sigma dAy^2 = I_G$ . Substituting these values in the above equation, we get

$$I_{AB} = h^2 . A + I_G + 2h \Sigma dAy. \quad \dots(ii)$$

But  $dA . y$  represents the moment of area of strip about X-X axis. And  $\Sigma dAy$  represents the moments of the total area about X-X axis. But the moments of the total area about X-X axis is equal to the product of total area (A) and the distance of the C.G. of the total area from X-X axis. As the distance of the C.G. of the total area from X-X axis is zero, hence  $\Sigma dAy$  will be equal to zero.

Substituting this value in equation (ii), we get

$$I_{AB} = h^2 . A + I_G + 0$$

or  $I_{AB} = I_G + Ah^2$  ... (5.8)

Thus if the moment of inertia of an area with respect to an axis in the plane of area (and passing through the C.G. of the area) is known, the moment of inertia with respect to any parallel axis in the plane may be determined by using the above equation.

**5.10. DETERMINATION OF AREA MOMENT OF INERTIA**

The area moment of inertia of the following sections will be determined by the method of integration :

1. Moment of inertia of a rectangular section,
2. Moment of inertia of a circular section,
3. Moment of inertia of a triangular section,
4. Moment of inertia of a uniform thin rod.

**5.10.1. Moment of Inertia of a Rectangular Section**

**1st Case. Moment of inertia of the rectangular section about the X-X axis passing through the C.G. of the section.**

Fig. 5.15 shows a rectangular section ABCD having width = b and depth = d. Let X-X be the horizontal axis passing through the C.G. of the rectangular section. We want to determine the moment of inertia of the rectangular section about X-X axis. The moment of inertia of the given section about X-X axis is represent by  $I_{XX}$ .

Consider a rectangular elementary strip of thickness dy at a distance y from the X-X axis as shown in Fig. 5.15.

Area of the strip =  $b . dy$ .

Moment of inertia of the area of the strip about X-X axis =  
 Area of strip  $\times y^2$   
 $= (b . dy) \times y^2 = by^2 dy$ .

Moment of inertia of the whole section will be obtained by integrating the above equation between the limits  $-\frac{d}{2}$  to  $\frac{d}{2}$ .

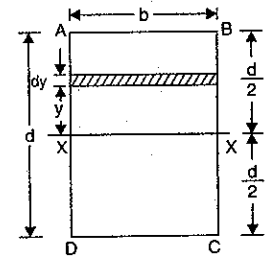

Fig. 5.15

$$\begin{aligned} \therefore I_{XX} &= \int_{-d/2}^{d/2} by^2 dy = b \int_{-d/2}^{d/2} y^2 dy \\ & (\because b \text{ is constant and can be taken outside the integral sign}) \\ &= b \left[ \frac{y^3}{3} \right]_{-d/2}^{d/2} = \frac{b}{3} \left[ \left( \frac{d}{2} \right)^3 - \left( -\frac{d}{2} \right)^3 \right] \\ &= \frac{b}{3} \left[ \frac{d^3}{8} - \left( -\frac{d^3}{8} \right) \right] = \frac{b}{3} \left[ \frac{d^3}{8} + \frac{d^3}{8} \right] \end{aligned}$$

$$= \frac{b}{3} \cdot \frac{2d^3}{8} = \frac{bd^3}{12} \quad \dots(5.9)$$

Similarly, the moment of inertia of the rectangular section about Y-Y axis passing through the C.G. of the section is given by

$$I_{YY} = \frac{db^3}{12} \quad \dots(5.10)$$

Refer to Fig. 5.15 (a)

Area of strip,  $dA = d \times dx$

M.O.I. of strip above Y-Y axis  $= dA \times x^2$

$$= (d \times dx) \times x^2 \quad (\because dA = d \cdot dx)$$

$$= d \times x^2 \times dx$$

$$I_{YY} = \int_{-b/2}^{b/2} d \times x^2 \times dx = d \left[ \frac{x^3}{3} \right]_{-b/2}^{b/2}$$

$$= \frac{d}{3} \left[ \left( \frac{b}{2} \right)^3 - \left( -\frac{b}{2} \right)^3 \right]$$

$$= \frac{d}{3} \left[ \frac{b^3}{8} + \frac{b^3}{8} \right] = \frac{d}{3} \cdot \frac{b^3}{4} = \frac{db^3}{12}$$

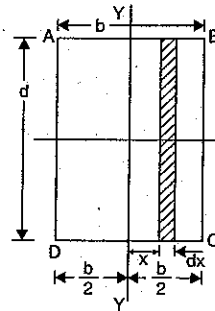

Fig. 5.15 (a)

**2nd Case. Moment of inertia of the rectangular section about a line passing through the base.**

Fig. 5.16 shows a rectangular section ABCD having width =  $b$  and depth =  $d$ . We want to find the moment of inertia of the rectangular section about the line CD, which is the base of the rectangular section.

Consider a rectangular elementary strip of thickness  $dy$  at a distance  $y$  from the line CD as shown in Fig. 5.16.

Area of strip =  $b \cdot dy$ .

Moment of inertia of the area of strip about the line CD

$$= \text{Area of strip} \cdot y^2$$

$$= b \cdot dy \cdot y^2 = by^2 dy.$$

Moment of inertia of the whole section about the line CD is obtained by integrating the above equation between the limits 0 to  $d$ .

$\therefore$  Moment of inertia of the whole section about the line CD.

$$= \int_0^d by^2 dy = b \int_0^d y^2 dy$$

$$= b \left[ \frac{y^3}{3} \right]_0^d = \frac{bd^3}{3} \quad \dots(5.11)$$

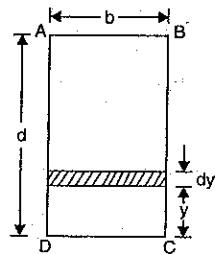

Fig. 5.16

**3rd Case. Moment of inertia of a hollow rectangular section.**

Fig. 5.17 shows a hollow rectangular section in which ABCD is the main section and EFGH is the cut-out section.

The moment of inertia of the main section ABCD about X-X axis is given by equation (5.7),

$$= \frac{bd^3}{12}$$

where  $b$  = Width of main section

$d$  = Depth.

The moment of inertia of the cut-out section EFGH about X-X axis

$$= \frac{b_1 d_1^3}{12}$$

where  $b_1$  = Width of the cut-out section, and

$d_1$  = Depth of the cut-out section.

Then moment of inertia of hollow rectangular section about X-X axis,

$I_{XX}$  = Moment of inertia of rectangle ABCD about X-X axis – moment of inertia of rectangle EFGH about X-X axis

$$= \frac{bd^3}{12} - \frac{b_1 d_1^3}{12}$$

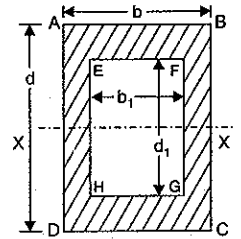

Fig. 5.17

**5.10.2. Moment of Inertia of a Circular Section.** Fig. 5.18 shows a circular section of radius  $R$  with  $O$  as centre. Consider an elementary circular ring of radius ' $r$ ' and thickness ' $dr$ '. Area of circular ring

$$= 2\pi r \cdot dr.$$

In this case first find the moment of inertia of the circular section about an axis passing through  $O$  and perpendicular to the plane of the paper. This moment of inertia is also known as **polar moment of inertia**. Let this axis be Z-Z. (Axis Z-Z is not shown in Fig. 5.18). Then from the theorem of perpendicular axis, the moment of inertia about X-X axis or Y-Y axis is obtained.

Moment of inertia of the circular ring about an axis passing through  $O$  and perpendicular to the plane of the paper

$$= (\text{Area of ring}) \times (\text{radius of ring from } O)^2$$

$$= (2\pi r \cdot dr) \cdot r^2$$

$$= 2\pi r^3 dr \quad \dots(i)$$

Moment of inertia of the whole circular section is obtained by integrating equation (i) between the limit 0 to  $R$ .

$\therefore$  Moment of inertia of the whole section about an axis passing through  $O$  and perpendicular to the plane of paper is given as

$$I_{ZZ} = \int_0^R 2\pi r^3 dr = 2\pi \int_0^R r^3 dr$$

$$= 2\pi \left[ \frac{r^4}{4} \right]_0^R = 2\pi \frac{R^4}{4} = \frac{\pi R^4}{2}$$

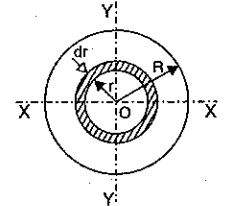

Fig. 5.18

But  $R = \frac{D}{2}$

where  $D =$  Diameter of the circular section

$$\therefore I_{ZZ} = \frac{\pi}{2} \times \left(\frac{D}{2}\right)^4 = \frac{\pi D^4}{32} \quad \dots(5.12)$$

or Polar moment of inertia  $= \frac{\pi D^4}{32}$

But from the theorem of perpendicular axis given by equation (5.7), we have  $I_{ZZ} = I_{XX} + I_{YY}$ .  
But due to symmetry,  $I_{XX} = I_{YY}$

$$\therefore I_{XX} = I_{YY} = \frac{I_{ZZ}}{2} = \frac{\pi D^4}{32} \times \frac{1}{2} = \frac{\pi D^4}{64} \quad \dots(5.13)$$

**Moment of Inertia of a hollow circular section**

Fig. 5.19 shows a hollow circular section.

Let  $D =$  Diameter of outer circle, and

$d =$  Diameter of cut-out circle.

Then from equation (5.13), the moment of inertia of the outer

circle about  $X-X$  axis  $= \frac{\pi}{64} D^4$ .

And moment of inertia of the cut-out circle about  $X-X$  axis

$$= \frac{\pi}{64} d^4.$$

$\therefore$  Moment of inertia of the hollow circular section, about  $X-X$  axis,

$I_{XX} =$  Moment of inertia of outer circle—moment of inertia of cut-out circle

$$= \frac{\pi}{64} D^4 - \frac{\pi}{64} d^4 = \frac{\pi}{64} [D^4 - d^4]$$

Similarly,  $I_{YY} = \frac{\pi}{64} [D^4 - d^4]$ .

**5.10.3. Moment of Inertia of a Triangular Section**

**1st Case. Moment of inertia of a triangular section about its base.**

Fig. 5.20 shows a triangular section  $ABC$  of base width  $= b$  and height  $= h$ . Consider a small strip of thickness  $dy$  at a distance  $y$  from the vertex  $A$ .

Area of the strip,  $= DE \cdot dy \quad \dots(i)$

The distance  $DE$  in terms of  $y, b$  and  $h$  is obtained from two similar triangles  $ADE$  and  $ABC$  as

$$\frac{DE}{BC} = \frac{y}{h}$$

$$\therefore DE = BC \cdot \frac{y}{h}$$

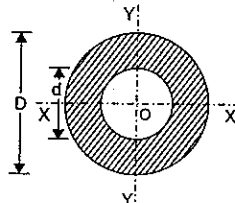

Fig. 5.19

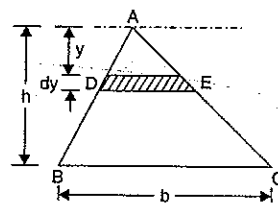

Fig. 5.20

$$= \frac{b \cdot y}{h} \quad (\because BC = b)$$

Substituting this value of  $DE$  in equation (i), we get

Area of strip  $= \frac{by}{h} \cdot dy$ .

Distance of the strip from the base  $= (h - y)$

$\therefore$  Moment of inertia of the strip about the base  $=$  Area of strip  $\times$  (Distance of strip from base)<sup>2</sup>

$$= \frac{by}{h} \cdot dy \cdot (h - y)^2 = \frac{by}{h} (h - y)^2 \cdot dy.$$

The moment of inertia of the whole triangular section about the base ( $I_{BC}$ ) is obtained by integrating the above equation between the limits  $O$  to  $h$ .

$$\begin{aligned} \therefore I_{BC} &= \int_0^h \frac{by}{h} [h - y]^2 dy \\ &= \frac{b}{h} \int_0^h y(h - y)^2 dy \\ (\because b \text{ and } h \text{ are constants and can be taken outside the integral sign}) \\ &= \frac{b}{h} \int_0^h y(h^2 + y^2 - 2hy) dy = \frac{b}{h} \int_0^h (yh^2 + y^3 - 2hy^2) dy \\ &= \frac{b}{h} \left[ \frac{y^2 h^2}{2} + \frac{y^4}{4} - \frac{2hy^3}{3} \right]_0^h \\ &= \frac{b}{h} \left[ \frac{h^2 \cdot h^2}{2} + \frac{h^4}{4} - \frac{2h \cdot h^3}{3} \right] = \frac{b}{h} \left[ \frac{h^4}{2} + \frac{h^4}{4} - \frac{2h^4}{3} \right] \\ &= \frac{b}{h} \cdot h^4 \left[ \frac{6 + 3 - 8}{12} \right] = bh^3 \cdot \frac{1}{12} \\ &= \frac{bh^3}{12} \quad \dots(5.14) \end{aligned}$$

**2nd Case. Moment of inertia of the triangular section about an axis passing through the C.G. and parallel to the base.**

Consider a triangular section of base  $= b$  and height  $= h$  as shown in Fig. 5.21. Let  $X-X$  is the axis passing through the C.G. of the triangular section and parallel to the base.

The distance between the C.G. of the triangular section and base  $AB = \frac{h}{3}$ .

Now from the theorem of parallel axis, given by equation (5.8), we have

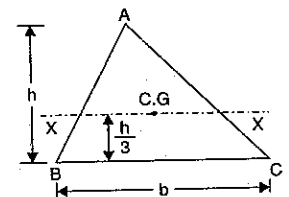

Fig. 5.21

Moment of inertia about

$$I_{BC} = \text{Moment of inertia about C.G.} + \text{Area} \times (\text{Distance between X-X and BC})^2$$

or 
$$I_{BC} = I_G + A \times \left(\frac{h}{3}\right)^2$$

$$\begin{aligned} \therefore I_G &= I_{BC} - A \times \left(\frac{h}{3}\right)^2 \\ &= \frac{bh^3}{12} - \left(\frac{b \times h}{2}\right) \cdot \left(\frac{h}{3}\right)^2 \quad \left[ \because I_{BC} = \frac{bh^3}{12} \text{ and Area} = \frac{b \times h}{2} \right] \\ &= \frac{bh^3}{12} - \frac{bh^3}{18} = \frac{bh^3(3-2)}{36} \\ &= \frac{bh^3}{36} \end{aligned} \quad \dots(5.15)$$

**Problem 5.13 (A).** Determine the moment of inertia of the section about an axis passing through the base BC of a triangular section shown in Fig. 5.21 (a).

(U.P. Tech. University, 2002-2003)

**Sol. Given :**

Base,  $b = 100 \text{ mm}$  ; height,  $h = 90 \text{ mm}$ .

Moment of inertia of a triangular section about an axis passing through the base is given by equation (5.14) as

$$\begin{aligned} I_{BC} &= \frac{bh^3}{12} \\ &= \frac{100 \times 90^3}{12} = 6.075 \times 10^6 \text{ mm}^4. \text{ Ans.} \end{aligned}$$

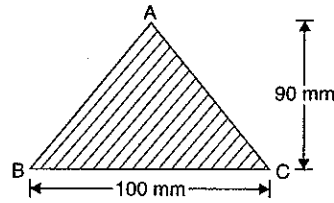

Fig. 5.21 (a)

**5.10.4. Moment of Inertia of a Uniform Thin Rod.**

Consider a uniform thin rod AB of length  $L$  as shown in Fig. 5.22.

Let  $m =$  Mass per unit length of rod, and

$M =$  Total mass of the rod

$$= m \times L \quad \dots(i)$$

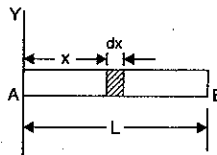

Fig. 5.22

Suppose it is required to find the moment of inertia of the rod about the axis Y-Y. Consider a strip of length  $dx$  at a distance  $x$  from the axis Y-Y.

$$\begin{aligned} \text{Mass of the strip} &= \text{Length of strip} \times \text{Mass per unit length} \\ &= dx \cdot m \text{ or } m \cdot dx. \end{aligned}$$

Moment of inertia of the strip about Y-Y axis

$$\begin{aligned} &= \text{Mass of strip} \times x^2 \\ &= (m \cdot dx) \cdot x^2 \\ &= mx^2 dx. \end{aligned}$$

Moment of inertia of the whole rod ( $I_{YY}$ ) will be obtained by integrating the above equation between the limits  $O$  to  $L$ .

$$\begin{aligned} \therefore I_{YY} &= \int_0^L mx^2 dx = m \int_0^L x^2 dx \quad (\because m \text{ is constant}) \\ &= m \left[ \frac{x^3}{3} \right]_0^L = \frac{mL^3}{3} \\ &= \frac{mL \cdot L^2}{3} = \frac{ML^2}{3} \quad [\because m \cdot L = M \text{ from equation (i)}] \end{aligned}$$

**5.10.5. Moment of Inertia of Area Under a Curve of given Equation.** Fig. 5.22 (a) shows an area under a curve whose equation is parabolic and is given by

$$\begin{aligned} x &= ky^2 \\ y &= b \text{ when } x = a \end{aligned}$$

in which

Suppose it is required to find the moment of inertia of this area about y-axis. Consider a strip of thickness  $dx$  at a distance  $x$  from y-axis.

$$\text{The area of strip, } dA = y dx \quad \dots(i)$$

Let us substitute the value of  $y$  in terms of  $x$  in the above equation. The equation of curve is

$$x = ky^2 \quad \dots(ii)$$

First find the value of  $k$ .

When  $y = b$ ,  $x = a$ . Hence above equation becomes

$$a = kb^2$$

or 
$$k = \frac{a}{b^2}$$

Substituting the value of ' $k$ ' in equation (ii), we get

$$x = \frac{a}{b^2} \cdot y^2 \text{ or } y^2 = \frac{b^2 x}{a}$$

or 
$$y = \left(\frac{b^2 x}{a}\right)^{1/2} = \frac{b}{\sqrt{a}} \sqrt{x} \quad \dots(iii)$$

Substituting this value of  $y$  in equation (i), we get

$$dA = \frac{b}{\sqrt{a}} \cdot \sqrt{x} \cdot dx$$

The moment of inertia of elemental area ( $dA$ ) about y-axis

$$= x^2 \cdot dA = x^2 \cdot \frac{b}{\sqrt{a}} \cdot \sqrt{x} dx$$

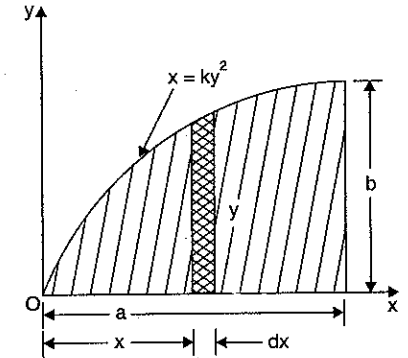

5.22 (a)

∴ Moment of inertia of the total area about  $y$ -axis is obtained by integrating the above equation between the limits  $O$  to  $a$ .  
 (∵  $x$  varies from  $O$  to  $a$ )

$$I_{yy} = \int_0^a x^2 \cdot \frac{b}{\sqrt{a}} \cdot \sqrt{x} \cdot dx = \frac{b}{\sqrt{a}} \int_0^a x^{5/2} \cdot dx$$

$$= \frac{b}{\sqrt{a}} \left[ \frac{x^{7/2}}{7/2} \right]_0^a = \frac{2}{7} \cdot \frac{b}{\sqrt{a}} \cdot a^{7/2} = \frac{2}{7} ba^2. \text{ Ans.}$$

To find the moment of inertia of the given area about  $x$ -axis, the element shown in Fig. 5.22 (a) can be considered to be a rectangle of thickness  $dx$ . The moment of inertia of this element about  $x$ -axis is equal to the moment of inertia of the rectangle about its base.

∴ Moment of inertia of the element about  $x$ -axis

$$= \frac{dx \cdot y^3}{3} \quad \left[ \because \text{it is } \frac{bd^3}{3} \text{ where } b = dx \text{ and } d = y \right]$$

The moment of inertia of the given area about  $x$ -axis is obtained by integrating the above equation between the limits  $O$  to  $a$ .

$$I_{xx} = \int_0^a \frac{dx \cdot y^3}{3} = \int_0^a \frac{y^3}{3} \cdot dx$$

$$= \int_0^a \frac{\left[ \frac{b}{\sqrt{a}} \cdot \sqrt{x} \right]^3 dx}{3} \quad \left[ \because y = \frac{b}{\sqrt{a}} \sqrt{x} \text{ from equation (iii)} \right]$$

$$= \frac{b^3}{3a^{3/2}} \int_0^a x^{3/2} dx = \frac{b^3}{3a^{3/2}} \left[ \frac{x^{5/2}}{5/2} \right]_0^a$$

$$= \frac{b^3}{3 \cdot a^{3/2}} \cdot \frac{2}{5} \cdot a^{5/2} = \frac{2}{15} b^3 \cdot a = \frac{2}{15} ab^3. \text{ Ans.}$$

**Problem 5.14.** Fig. 5.23 shows a T-section of dimensions  $10 \times 10 \times 2$  cm. Determine the moment of inertia of the section about the horizontal and vertical axes, passing through the centre of gravity of the section. Also find the polar moment of inertia of the given T-section.

**Sol.** First of all, find the location of centre of gravity of the given T-section. The given section is symmetrical about the axis  $Y-Y$  and hence the C.G. of the section will lie on  $Y-Y$  axis. The given section is split up into two rectangles  $ABCD$  and  $EFGH$  for calculating the C.G. of the section.

Let  $\bar{y}$  = Distance of the C.G. of the section from the bottom line  $GF$

$$a_1 = \text{Area of rectangle } ABCD = 10 \times 2 = 20 \text{ cm}^2$$

$$y_2 = \text{Distance of C.G. of the area } a_1 \text{ from the bottom line } GF = 8 + 1 = 9 \text{ cm}$$

$$a_2 = \text{Area of rectangle } EFGH = 8 \times 2 = 16 \text{ cm}^2$$

$$y_2 = \text{Distance of C.G. of rectangle } EFGH \text{ from the bottom line } GF = \frac{8}{2} = 4 \text{ cm}$$

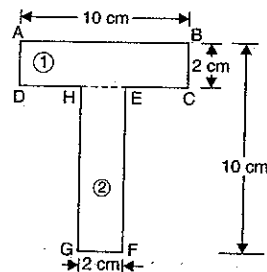

Fig. 5.23

$$\bar{y} = \frac{a_1 y_1 + a_2 y_2}{a_1 + a_2} = \frac{20 \times 9 + 16 \times 4}{20 + 16} = \frac{180 + 64}{36} = \frac{244}{36} = 6.777 \text{ cm.}$$

Hence the C.G. of the given section lies at a distance of 6.777 cm from  $GF$ . Now find the moment of inertia of the T-section.

Now, Let  $I_{G_1}$  = Moment of inertia of rectangle (1) about the horizontal axis and passing through its C.G.

$I_{G_2}$  = Moment of inertia of rectangle (2) about the horizontal axis and passing through the C.G. of the rectangle (2)

$h_1$  = The distance between the C.G. of the given section and the C.G. of the rectangle (1)

$$= y_1 - \bar{y} = 9.0 - 6.777 = 2.223 \text{ cm}$$

$h_2$  = The distance between the C.G. of the given section and the C.G. of the rectangle (2)

$$= \bar{y} - y_2 = 6.777 - 4.0 = 2.777 \text{ cm.}$$

$$\text{Now } I_{G_1} = \frac{10 \times 2^3}{2} = 6.667 \text{ cm}^4$$

$$I_{G_2} = \frac{2 \times 8^3}{12} = 85.333 \text{ cm}^4.$$

From the theorem of parallel axes, the moment of inertia of the rectangle (1) about the horizontal axis passing through the C.G. of the given section

$$= I_{G_1} + a_1 h_1^2 = 6.667 + 20 \times (2.223)^2$$

$$= 6.667 + 98.834 = 105.501 \text{ cm}^4.$$

Similarly, the moment of inertia of the rectangle (2) about the horizontal axis passing through the C.G. of the given section

$$= I_{G_2} + a_2 h_2^2 = 85.333 + 16 \times (2.777)^2$$

$$= 85.333 + 123.387 = 208.72 \text{ cm}^4.$$

∴ The moment of inertia of the given section about the horizontal axis passing through the C.G. of the given section is,

$$I_{xx} = 105.501 + 208.72 = 314.221 \text{ cm}^4. \text{ Ans.}$$

The moment of inertia of the given section about the vertical axis passing through the C.G. of the given section is,

$$I_{yy} = \frac{2 \times 10^3}{12} + \frac{8 \times 2^3}{12}$$

$$= 166.67 + 5.33 = 172 \text{ cm}^4. \text{ Ans.}$$

Now the polar moment of inertia ( $I_{zz}$ ) is obtained from equation (5.7) as

$$I_{zz} = I_{xx} + I_{yy}$$

$$= 314.221 + 172 = 486.221 \text{ cm}^4. \text{ Ans.}$$

**Problem 5.15.** Find the moment of inertia of the section shown in Fig. 5.24 about the centroidal axis  $X-X$  perpendicular to the web.

(AMIE, Summer 1977)

**Sol.** First of all find the location of centre of gravity of the given figure. The given section is symmetrical about the axis

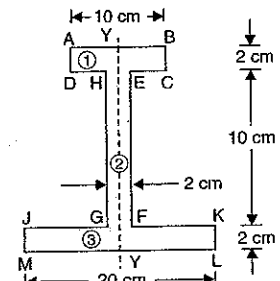

Fig. 5.24

$Y-Y$  and hence the C.G. of the section will lie on  $Y-Y$  axis. The given section is split up into three rectangles  $ABCD$ ,  $EFGH$  and  $JKLM$ . The centre of gravity of the section is obtained by using

$$\bar{y} = \frac{a_1 y_1 + a_2 y_2 + a_3 y_3}{a_1 + a_2 + a_3} \quad \dots(i)$$

where  $\bar{y}$  = Distance of the C.G. of the section from the bottom line  $ML$

$$a_1 = \text{Area of rectangle } ABCD = 10 \times 2 = 20 \text{ cm}^2$$

$$y_1 = \text{Distance of the C.G. of the rectangle } ABCD \text{ from the bottom line } ML$$

$$= 2 + 10 + \frac{2}{2} = 12 + 1 = 13 \text{ cm}$$

$$a_2 = \text{Area of rectangle } EFGH = 10 \times 2 = 20 \text{ cm}^2$$

$$y_2 = \text{Distance of the C.G. of rectangle } EFGH \text{ from the bottom line } ML$$

$$= 2 + \frac{10}{2} = 2 + 5 = 7 \text{ cm}$$

$$a_3 = \text{Area of rectangle } JKLM = 20 \times 2 = 40 \text{ cm}^2$$

$$y_3 = \text{Distance of the C.G. of rectangle } JKLM \text{ from the bottom line } ML$$

$$= \frac{2}{2} = 1.0 \text{ cm.}$$

Substituting the above values in equation (i), we get

$$\begin{aligned} \bar{y} &= \frac{20 \times 13 + 20 \times 7 + 40 \times 1}{20 + 20 + 40} \\ &= \frac{260 + 140 + 40}{80} = \frac{440}{80} = 5.50 \text{ cm.} \end{aligned}$$

The C.G. of the given section lies at a distance of 5.50 cm from the bottom line  $ML$ . We want to find the moment of inertia of the given section about a horizontal axis passing through the C.G. of the given section.

Let  $I_{G_1}$  = Moment of inertia of rectangle (1) about the horizontal axis passing through its C.G.

$I_{G_2}$  = Moment of inertia of rectangle (2) about the horizontal axis passing through the C.G. of rectangle (2)

$I_{G_3}$  = Moment of inertia of rectangle (3) about the horizontal axis passing through the C.G. of rectangle (3)

$h_1$  = The distance between the C.G. of the rectangle (1) and the C.G. of the given section

$$= y_1 - \bar{y} = 13.0 - 5.50 = 7.50 \text{ cm}$$

$h_2$  = The distance between the C.G. of rectangle (2) and the C.G. of the given section

$$= y_2 - \bar{y} = 7.0 - 5.50 = 1.50 \text{ cm}$$

$h_3$  = The distance between the C.G. of the rectangle (3) and the C.G. of the given section

$$= \bar{y} - y_3 = 5.50 - 1.0 = 4.5 \text{ cm}$$

$$\text{Now } I_{G_1} = \frac{10 \times 2^3}{12} = 6.667 \text{ cm}^4$$

$$I_{G_2} = \frac{2 \times 10^3}{12} = 166.667 \text{ cm}^4$$

$$I_{G_3} = \frac{20 \times 2^3}{12} = 13.333 \text{ cm}^4.$$

From the theorem of parallel axes, the moment of inertia of the rectangle (1) about the horizontal axis passing through the C.G. of the given section

$$= I_{G_1} + a_1 h_1^2 = 6.667 + 20 \times (7.5)^2$$

$$= 6.667 + 1125 = 1131.667 \text{ cm}^4.$$

Similarly, the moment of inertia of the rectangle (2) about the horizontal axis passing through the C.G. of the given section

$$= I_{G_2} + a_2 h_2^2 = 166.667 + 20 \times 1.5^2$$

$$= 166.667 + 45 = 211.667 \text{ cm}^4.$$

And moment of inertia of the rectangle (3) about the horizontal axis, passing through the C.G. of the given section

$$= I_{G_3} + a_3 h_3^2 = 13.333 + 40 \times 4.5^2$$

$$= 13.333 + 810 = 823.333 \text{ cm}^4$$

Now moment of inertia of the given section about the horizontal axis, passing through the C.G. of the given section

= Sum of the moment of inertia of the rectangles (1), (2) and (3) about the horizontal axis, passing through the C.G. of the given section

$$= 1131.667 + 211.667 + 823.333 = \mathbf{2166.667 \text{ cm}^4. \text{ Ans.}}$$

**Problem 5.15(A).** Determine the polar moment of inertia of I-section shown in Fig. 5.24 (a). (All dimensions are in mm). (U.P. Tech. University, 2001-2002)

**Sol.** Let us first find the location of C.G. of the given section. It is symmetrical about the vertical axis, hence C.G. lies on this section.

Now,  $A_1$  = Area of first rectangle  
 $= 80 \times 12 = 960 \text{ mm}^2$

$A_2$  = Area of second rectangle

$$[(150 - 12 - 10) \times 12]$$

$$= 128 \times 12 = 1536 \text{ mm}^2$$

$A_3$  = Area of third rectangle

$$= 120 \times 10 = 1200 \text{ mm}^2$$

$y_1$  = Distance of C.G. of area  $A_1$  from bottom line

$$= 150 - \frac{12}{2} = 144 \text{ mm}$$

$y_2$  = Distance of C.G. of area  $A_2$  from bottom line

$$= 10 + \frac{128}{2} = 74 \text{ mm}$$

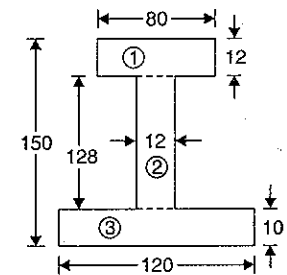

Fig. 5.24 (a)

$$y_3 = \text{Distance of C.G. of area } A_3 \text{ from bottom line} = \frac{10}{2} = 5 \text{ cm.}$$

$\bar{y}$  = Distance of C.G. of the given section from bottom line.

The C.G. of the section is obtained by using,

$$\begin{aligned} \bar{y} &= \frac{A_1 y_1 + A_2 y_2 + A_3 y_3}{A_1 + A_2 + A_3} \\ &= \frac{960 \times 144 + 1536 \times 74 + 1200 \times 5}{960 + 1536 + 1200} \\ &= \frac{138240 + 113664 + 6000}{3696} = \frac{257904}{3696} \\ &= 69.779 \approx 69.78 \text{ cm} \end{aligned}$$

Location of centroidal axis is shown in Fig. 5.24 (b).

(i) **Moment of inertia of the given section about X-X**

M.O.I. of the rectangle ① about centroidal axis X-X is given by,

$$\begin{aligned} I_{XX1} &= (I_{G_1})_X + A_1 \times h_1^2 \quad \text{where } h_1 = (y_1 - \bar{y}) \\ &= \frac{80 \times 12^3}{12} + 960(144 - 69.78)^2 = 5.3 \times 10^6 \text{ mm}^4 \end{aligned}$$

M.O.I. of rectangle ② about centroidal axis X-X is given by,

$$\begin{aligned} I_{XX2} &= (I_{G_2})_X + A_2 \times h_2^2 \quad \text{where } h_2 = (y_2 - \bar{y}) \\ &= \frac{12 \times 128^3}{12} + 1536 \times (74 - 69.78)^2 \\ &= 2.12 \times 10^6 \text{ mm}^4 \end{aligned}$$

and  $I_{XX3} = (I_{G_3})_X + A_3 \times h_3^2$  where  $h_3 = (y_3 - \bar{y})$

$$= \frac{120 \times 10^3}{12} + 1200 \times (5 - 69.78)^2 = 5.04 \times 10^6 \text{ mm}^4$$

$$\begin{aligned} \therefore I_{XX} &= I_{XX1} + I_{XX2} + I_{XX3} \\ &= 5.3 \times 10^6 + 2.12 \times 10^6 + 5.04 \times 10^6 \text{ mm}^4 \\ &= 12.46 \times 10^6 \text{ mm}^4 \end{aligned}$$

(ii) **M.O.I. of the given section about Y-Y**

$$I_{YY1} = (I_{G_1})_Y = \frac{12 \times 80^3}{12} = 521 \times 10^3 \text{ mm}^4 = 0.521 \times 10^6 \text{ mm}^4$$

$$I_{YY2} = (I_{G_2})_Y = \frac{128 \times 12^3}{12} = 18.432 \times 10^3 \text{ mm}^4 = 0.018432 \times 10^6 \text{ mm}^4$$

$$I_{YY3} = (I_{G_3})_Y = \frac{10 \times 120^3}{12} = 1.44 \times 10^6 \text{ mm}^4$$

$$\begin{aligned} I_{YY} &= I_{YY1} + I_{YY2} + I_{YY3} \\ &= 0.521 \times 10^6 + 0.018432 \times 10^6 + 1.44 \times 10^6 \text{ mm}^4 = 1.979 \times 10^6 \text{ mm}^4 \end{aligned}$$

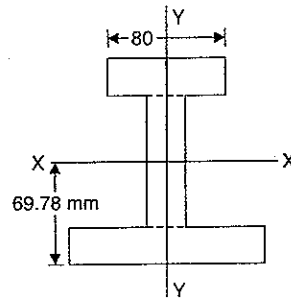

Fig. 5.24 (b)

$\therefore$  Polar moment of inertia ( $I_{ZZ}$ ) is given by,

$$\begin{aligned} I_{ZZ} &= I_{XX} + I_{YY} \\ &= 12.46 \times 10^6 + 1.979 \times 10^6 \text{ mm}^4 \\ &= 14.439 \times 10^6 \text{ mm}^4. \quad \text{Ans.} \end{aligned}$$

**Problem 5.16.** Find the moment of inertia of the area shown shaded in Fig 5.25, about edge AB.

**Sol. Given :**

Radius of semi-circle,  $R = 10 \text{ cm}$

Width of rectangle,  $b = 20 \text{ cm}$

Depth of rectangle,  $d = 25 \text{ cm}$

Moment of inertia of the shaded portion about AB

$$= \text{M.O.I. of rectangle } ABCD \text{ about } AB$$

$$- \text{M.O.I. of semi-circle on } DC \text{ about } AB$$

M.O.I. of rectangle ABCD about AB

$$= \frac{bd^3}{3}$$

[see equation (5.11)]

$$= \frac{20 \times 25^3}{12} = 104.167 \text{ cm}^4$$

M.O.I. of semi-circle about DC

$$= \frac{1}{2} \times [\text{M.O.I. of a circle of radius 10 cm about a diameter}]$$

$$= \frac{1}{2} \times \left[ \frac{\pi}{64} d^4 \right] = \frac{1}{2} \times \frac{\pi}{64} \times 20^4 = 3.925 \text{ cm}^4$$

Distance of C.G. of semi-circle from DC

$$= \frac{4r}{3\pi} = \frac{4 \times 10}{3\pi} = 4.24 \text{ cm}$$

$$\text{Area of semi-circle, } A = \frac{\pi r^2}{2} = \frac{\pi \times 10^2}{2} = 157.1 \text{ cm}^2$$

M.O.I. of semi-circle about a line through its C.G. parallel to CD

$$= \text{M.O.I. of semi-circle about } CD - \text{Area} \times [\text{Distance of C.G. of semi-circle from } DC]^2$$

$$= 3925 - 157.1 \times 4.24^2$$

$$= 3925 - 2824.28 = 1100.72 \text{ cm}^4$$

Distance of C.G. of semi-circle from AB

$$= 25 - 4.24 = 20.76 \text{ cm}$$

M.O.I. of semi-circle about AB = 1100.72 + 157.1 × 20.76<sup>2</sup>

$$= 1100.72 + 67706.58 = 68807.30 \text{ cm}^4$$

$\therefore$  M.O.I. of shaded portion about AB

$$= 104.167 - 68807.30 = 35359.7 \text{ cm}^4. \quad \text{Ans.}$$

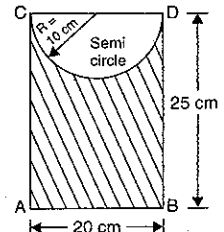

Fig. 5.25



**Problem 5.16 (A).** Find the moments of inertia about the centroidal  $XX$  and  $YY$  axes of the section shown in Fig. 5.25 (a). (U.P. Tech. University, 2002-2003)

**Sol.** First find the location of the C.G. of the given figure:

Let  $a_1 =$  Area of complete rectangle  
 $= B \times D$

$a_2 =$  Area of removed rectangle portion

$$= \frac{B}{2} \times \frac{D}{2} = \frac{BD}{4}$$

$$x_1 = \frac{B}{2}, y_1 = \frac{D}{2} \text{ and}$$

$$x_2 = \frac{B}{2} + \frac{1}{2} \left( \frac{B}{2} \right) = \frac{3B}{4},$$

$$y_2 = \frac{D}{2} + \frac{1}{2} \left( \frac{D}{2} \right) = \frac{3D}{4}$$

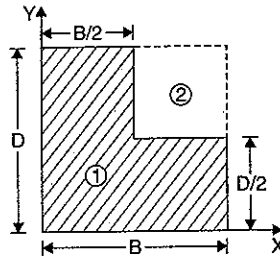

Fig. 5.25 (a)

where  $(x_1, y_1)$  and  $(x_2, y_2)$  are the co-ordinates of the C.G. of the complete rectangle and cut out rectangle respectively. Area  $a_2$  is negative.

$$\text{Now } \bar{x} = \frac{a_1 x_1 - a_2 x_2}{a_1 - a_2} = \frac{BD \times \frac{B}{2} - \frac{B \times D}{4} \times \frac{3B}{4}}{\frac{3}{4} BD}$$

$$= \frac{\frac{B^2 \times D}{2} - \frac{3}{16} B^2 D}{\frac{3}{4} BD} = \frac{\frac{5}{16} BD^2}{\frac{3}{4} BD} = \frac{5}{12} \times D$$

$$\text{Similarly, } \bar{y} = \frac{a_1 y_1 - a_2 y_2}{a_1 - a_2} = \frac{BD \times \frac{D}{2} - \frac{BD}{4} \times \frac{3D}{4}}{\frac{3}{4} BD}$$

$$= \frac{\frac{BD^2}{2} - \frac{3}{16} BD^2}{\frac{3}{4} BD} = \frac{\frac{5}{16} BD^2}{\frac{3}{4} BD} = \frac{5}{12} \times D$$

Now draw the centroidal axes  $XX$  and  $YY$  as shown in Fig. 5.25 (b).

Let  $I_{XX1} =$  M.O.I. of complete rectangle  $\textcircled{1}$  about centroidal axis  $X-X$

$=$  M.O.I. of complete rectangle  $\textcircled{1}$  about horizontal axis passing through its C.G.

+ Area of complete rectangle  $\textcircled{1}$

$\times$  Distance between  $X-X$  axis and horizontal axis passing through the C.G. of rectangle  $\textcircled{1}$  (By theorem of parallel axis)  $[\because I_{XX1} = I_{G1xx} + A_1 h_1^2]$

$$= \frac{BD^3}{12} + (B \times D) [y_1 - \bar{y}]^2$$

$$= \frac{BD^3}{12} + BD \left[ \frac{D}{2} - \frac{5D}{12} \right]^2$$

$$= \frac{BD^3}{12} + BD \left[ \frac{D}{12} \right]^2$$

$$[\because y_1 = \frac{D}{2}, \bar{y} = \frac{5D}{12}]$$

$$= \frac{BD^3}{12} + \frac{BD^3}{144} = \frac{13}{144} BD^3$$

$$\text{Similarly, } I_{XX2} = (I_{G2x}) + A_2 \times h_2^2$$

$$= \frac{B}{2} \times \left( \frac{D}{2} \right)^3 + \frac{BD}{4} \times [y_2 - \bar{y}]^2$$

$$[\because A_2 = \frac{BD}{4}, h_2 = (y_2 - \bar{y})]$$

$$= \frac{BD^3}{192} + \frac{BD}{4} \left[ \frac{3D}{4} - \frac{5D}{12} \right]^2$$

$$[\because y_2 = \frac{3D}{2}, \bar{y} = \frac{5D}{12}]$$

$$= \frac{BD^3}{192} + \frac{BD}{4} \times \left( \frac{4D}{12} \right)^2 = \frac{BD^3}{192} + \frac{16BD^3}{4 \times 144}$$

$$= \frac{BD^3}{192} + \frac{BD^3}{36} = \frac{3BD^3 + 16BD^3}{576} = \frac{19BD^3}{576}$$

Now  $I_{XX} =$  M.O.I. of given section about centroidal axis  $X-X$

$$= I_{XX1} - I_{XX2}$$

$$= \frac{13BD^3}{144} - \frac{19BD^3}{576} = \frac{52BD^3 - 19BD^3}{576} = \frac{33BD^3}{576} = 0.0573 BD^3. \text{ Ans.}$$

Similarly, the M.O.I. of the given section about centroidal axis  $Y-Y$  is given by

$$I_{YY} = I_{YY1} - I_{YY2}$$

where

$I_{YY1} =$  M.O.I. of rectangle  $\textcircled{1}$  about centroidal axis  $Y-Y$

$$= I_{G1y} + A_1 \times [x_1 - \bar{x}]^2$$

$$= \frac{DB^3}{12} + BD \times \left[ \frac{B}{2} - \frac{5B}{12} \right]^2 = \frac{DB^3}{12} + \frac{BD \times B^2}{144} = \frac{13}{144} DB^3$$

and

$$I_{YY2} = I_{G2y} + A_2 [x_2 - \bar{x}]^2$$

$$= \frac{D}{2} \times \left( \frac{B}{2} \right)^3 + \frac{BD}{4} \left[ \frac{3B}{4} - \frac{5B}{12} \right]^2 = \frac{DB^3}{192} + \frac{DB^3}{36} = \frac{19DB^3}{576}$$

$$\therefore I_{YY} = \frac{13}{144} DB^3 - \frac{19DB^3}{576} = \frac{33}{576} DB^3 = 0.0573 DB^3. \text{ Ans.}$$

### 5.11. MASS MOMENT OF INERTIA

Consider a body of mass  $M$  as shown in Fig. 5.26.

Let  $x =$  Distance of the centre of gravity of mass  $M$  from axis  $OY$

$y =$  Distances of the C.G. of mass  $M$  from axis  $OX$

Then moment of the mass about the axis  $OY = M \cdot x$

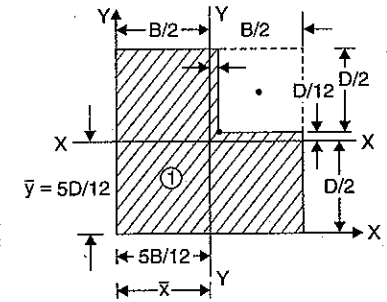

Fig. 5.25 (b)

The above equation is known as *first moment of mass about the axis OY*.

If the moment of mass given by the above equation is again multiplied by the perpendicular distance between the C.G. of the mass and axis OY, then the quantity  $(M \cdot x) \cdot x = M \cdot x^2$  is known as *second moment of mass about the axis OY*. This second moment of the mass (i.e., quantity  $M \cdot x^2$ ) is known as mass moment of inertia about the axis OY.

Similarly, the second moment of mass or mass moment of inertia about the axis OX

$$= (M \cdot y) \cdot y = M \cdot y^2$$

Hence the product of the mass and the square of the distance of the centre of gravity of the mass from an axis is known as the mass moment of inertia about that axis. Mass moment of inertia is represented by  $I_m$ . Hence mass moment of inertia about the axis OX is represented by  $(I_m)_{xx}$  whereas about the axis OY by  $(I_m)_{yy}$ .

Consider a body which is split up into small masses  $m_1, m_2, m_3, \dots$  etc. Let the C.G. of the small areas from a given axis be at a distance of  $r_1, r_2, r_3, \dots$  etc. as shown in Fig. 5.27. Then mass moment of inertia of the body about the given axis is given by

$$I_m = m_1 r_1^2 + m_2 r_2^2 + m_3 r_3^2 + \dots = \Sigma m r^2$$

If small masses are large in number then the summation in the above equation can be replaced by integration. Let the small masses are replaced by  $dm$  instead of 'm', then the above equation can be written as

$$I_m = \int r^2 dm \quad \dots(5.16)$$

### 5.12. DETERMINATION OF MASS MOMENT OF INERTIA

The mass moment of inertia of the following bodies will be determined by the method of integration :

1. Mass moment of inertia of a rectangular plate,
2. Mass moment of inertia of a circular plate,
3. Mass moment of inertia of a hollow circular cylinder.

#### 5.12.1. Mass Moment of Inertia of a Rectangular Plate

(a) Mass moment of inertia of a rectangular plate about X-X axis passing through the C.G. of the plate.

Fig. 5.28 shows a rectangular plate of width  $b$ , depth  $d$  and uniform thickness  $t$ . Consider a small element of width  $b$  at a distance  $y$  from X-X axis as shown in Fig. 5.29.

Here X-X axis is the horizontal line passing through the C.G. of the plate.

Area of the element =  $b \times dy$

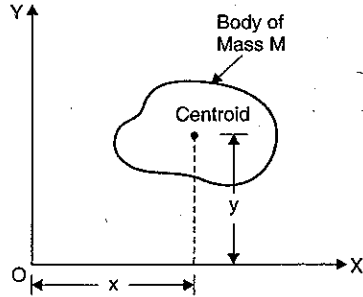

Fig. 5.26

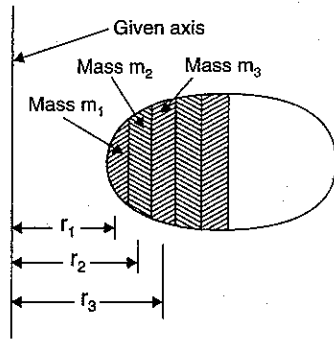

Fig. 5.27

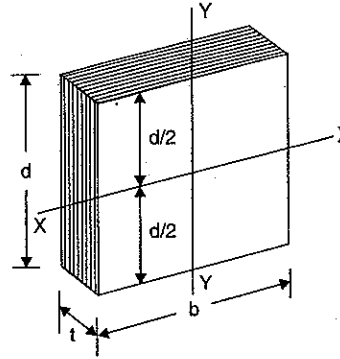

Fig. 5.28

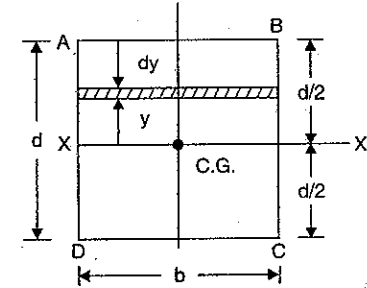

Fig. 5.29

$\therefore$  Mass of the element = Density  $\times$  Volume of element

$$= \rho \times [\text{Area} \times \text{thickness of element}]$$

$$= \rho \times [b \times dy \times t] \quad [\because \rho = \text{Density and } t = \text{thickness}]$$

$$= \rho b t \, dy$$

Mass moment of inertia of the element about X-X axis

$$= \text{Mass of element} \times y^2$$

$$= (\rho b t \, dy) \times y^2 = \rho b t \, y^2 \, dy$$

Mass moment of inertia of the plate will be obtained by integrating the above equation

between the limits  $-\frac{d}{2}$  to  $\frac{d}{2}$ .

$$\therefore (I_m)_{xx} = \int_{-d/2}^{d/2} \rho b t \, y^2 \, dy = \rho b t \int_{-d/2}^{d/2} y^2 \, dy$$

$[\because \rho, b, t$  are constant and can be taken outside the integral sign]

$$= \rho b t \left[ \frac{y^3}{3} \right]_{-d/2}^{d/2} = \frac{\rho b t}{3} \left[ \left( \frac{d}{2} \right)^3 - \left( -\frac{d}{2} \right)^3 \right]$$

$$= \frac{\rho b t}{3} \left[ \frac{d^3}{8} - \left( -\frac{d^3}{8} \right) \right] = \frac{\rho b t}{3} \left[ \frac{d^3}{8} + \frac{d^3}{8} \right] = \frac{\rho b t}{3} \times \frac{2d^3}{8}$$

$$= \frac{\rho b t}{12} d^3 = \rho \times t \frac{b d^3}{12} \quad \dots(5.17)$$

But  $\frac{b d^3}{12}$  is the moment of inertia of the area of the rectangular section about X-X axis.

This moment of inertia of the area is represented by  $I_{xx}$ .

$$\therefore (I_m)_{xx} = \rho \times t \times I_{xx} \quad \dots(5.18)$$

where  $(I_m)_{xx}$  = Mass moment of inertia of the plate about X-X axis passing through C.G. of the plate.

$I_{xx}$  = Moment of inertia of the area of the plate about X-X axis.

Again from equation (5.5), we have

$$\begin{aligned}(I_m)_{xx} &= \rho \frac{bd^3}{12} \\ &= \rho b \times d \times t \times \frac{d^2}{12} \\ &= M \times \frac{d^2}{12} \\ (\because M &= \text{Mass of the plate} = \rho \times \text{Volume of the plate} = \rho \times [b \times d \times t]) \\ &= \frac{1}{12} Md^2 \quad \dots(5.19)\end{aligned}$$

Similarly, the mass moment of inertia of the rectangular plate about Y-Y axis passing through the C.G. of the plate is given by

$$(I_m)_{yy} = \frac{1}{12} Mb^2 \quad \dots(5.20)$$

**(b) Mass moment of inertia of the rectangular plate about a line passing through the base.**

Fig. 5.30 shows a rectangular plate ABCD, having width =  $b$ , depth =  $d$  and uniform thickness =  $t$ . We want to find the mass moment of inertia of the rectangular plate about the line CD, which is the base of the plate. Consider a rectangular elementary strip of width  $b$ , thickness  $t$  and depth ' $dy$ ' at a distance  $y$  from the line CD as shown in Fig. 5.30.

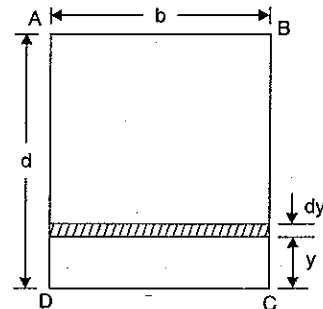

Fig. 5.30

$$\begin{aligned}\text{Area of strip, } dA &= b \cdot dy \\ \text{Volume of strip} &= dA \times t = b \cdot dy \cdot t = b \cdot t \cdot dy \\ \text{Mass of the strip, } dm &= \text{Density} \times \text{Volume of strip} \\ &= \rho(b \cdot t \cdot dy) = \rho \cdot b \cdot t \cdot dy \\ \text{Mass moment of inertia of the strip about the line CD} \\ &= \text{Mass of strip} \cdot y^2 \\ &= dm \cdot y^2 = y^2 \cdot dm\end{aligned}$$

Mass moment of inertia of the whole rectangular plate about the line CD is obtained by integrating the above equation between the limits 0 to  $d$ .

$\therefore$  Mass moment of inertia of the rectangular plate about the line CD

$$\begin{aligned}&= \int_0^d y^2 \cdot dm = \int_0^d y^2 \cdot (\rho \cdot b \cdot t \cdot dy) \quad [\because dm = \rho \cdot b \cdot t \cdot dy] \\ &= \rho \cdot b \cdot t \int_0^d y^2 dy \quad [\because \rho, b \text{ and } t \text{ are constant}] \\ &= \rho \cdot b \cdot t \cdot \left[ \frac{y^3}{3} \right]_0^d = \rho \cdot b \cdot t \cdot \frac{d^3}{3} = \rho \cdot b \cdot t \cdot d \cdot \frac{d^2}{3} \\ &= \frac{M \cdot d^2}{3} \quad \dots(5.21)\end{aligned}$$

$$[\because \rho \cdot b \cdot t \cdot d = \text{Mass of rectangular plate} = M]$$

**(c) Mass moment of inertia of a hollow rectangular plate.**

Fig. 5.31 shows a hollow rectangular plate in which ABCD is the main plate and EFGH is the cut-out section.

The mass moment of inertia of the main plate ABCD about X-X is given by equation

$$= \frac{1}{12} Md^2$$

The mass moment of inertia of the cut-out section EFGH about X-X axis

$$= \frac{1}{12} md_1^2$$

where  $M$  = Mass of main plate ABCD

$$= \rho \cdot b \cdot d \cdot t$$

$m$  = Mass of the cut-out section EFGH

$$= \rho \cdot b_1 \cdot d_1 \cdot t$$

Then mass moment of inertia of hollow rectangular plate about X-X axis is given by

$$(I_m)_{xx} = \frac{1}{12} Md^2 - \frac{1}{12} md_1^2 \quad \dots(5.22)$$

**5.12.2. Mass Moment of Inertia of a Circular Plate**

Fig. 5.32 shows a circular plate of radius  $R$  and thickness  $t$  with  $O$  as centre. Consider an elementary circular ring of radius ' $r$ ' and width  $dr$  as shown in Fig. 5.32 (a).

Area of ring,  $dA = 2\pi r \cdot dr$

Volume of ring = Area of ring  $\times t = dA \cdot t$   
 $= 2\pi r \cdot dr \cdot t$

Mass of ring,  $dm = \text{Density} \times \text{Volume of ring}$   
 $= \rho(2\pi r \cdot dr \cdot t)$

In this case first find the mass moment of inertia about an axis passing through  $O$  and perpendicular to the plane of the paper i.e., about axis Z-Z.

$\therefore$  Mass moment of inertia of the circular ring about axis Z-Z

$$\begin{aligned}&= (\text{Mass of ring}) \times (\text{radius of ring})^2 \\ &= dm \times r^2 = (\rho \cdot 2\pi r \cdot dr \cdot t) \times r^2 = \rho \cdot t \cdot 2\pi r^3 dr\end{aligned}$$

The mass moment of inertia of the whole circular plate will be obtained by integrating the above equation between the limits 0 to  $R$ .

$\therefore$  Mass moment of inertia of circular plate about Z-Z axis is given by

$$\begin{aligned}(I_m)_{zz} &= \int_0^R \rho \cdot t \cdot 2\pi r^3 dr = 2\pi \cdot \rho \cdot t \int_0^R r^3 dr \\ &= 2\pi \rho \cdot t \left[ \frac{r^4}{4} \right]_0^R\end{aligned}$$

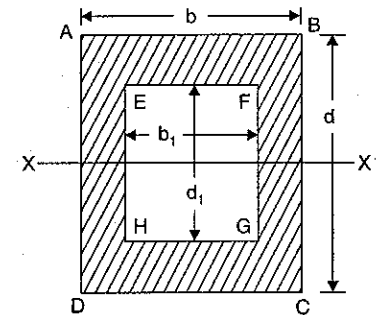

Fig. 5.31

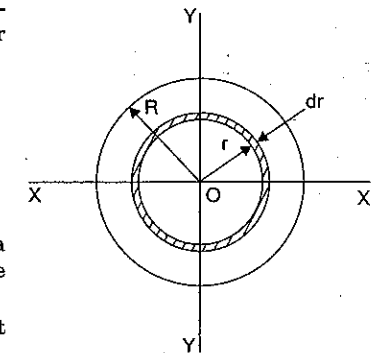

Fig. 5.32

$$= 2\pi \cdot \rho \cdot t \cdot \frac{R^4}{4} = \pi \cdot \rho \cdot t \cdot \frac{R^4}{2}$$

Now mass of circular plate,

$$M = \rho \times \text{Volume of plate}$$

$$= \rho \times \pi R^2 \times t$$

$$[\text{Volume of plate} = \text{Area} \times t = \pi R^2 \times t]$$

Substituting this value in above equation, we get

$$\therefore (I_m)_{zz} = \rho \times \pi R^2 \times t \times \frac{R^2}{2} = \frac{MR^2}{2} \quad \dots(5.23)$$

But from the theorem of perpendicular axis given by equation (5.7), we have

$$I_{zz} = I_{xx} + I_{yy}$$

$$(I_m)_{zz} = (I_m)_{xx} + (I_m)_{yy}$$

or

And due to symmetry, we have  $(I_m)_{xx} = (I_m)_{yy}$

$$\therefore (I_m)_{xx} = (I_m)_{yy} = (I_m)_{zz}/2$$

$$= \left( \frac{MR^2}{2} \right) / 2 = \frac{MR^2}{4} \quad \dots(5.24)$$

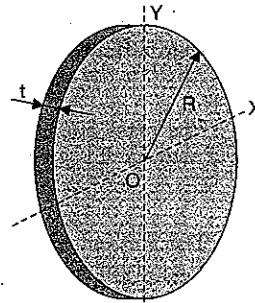

Fig. 5.32 (a)

### 5.12.3. Mass Moment of Inertia of a Hollow Circular Cylinder

Let  $R_0$  = Outer radius of the cylinder

$R_i$  = Inner radius of the cylinder

$L$  = Length of the cylinder

$M$  = Mass of cylinder

$$= \text{Density} \times \text{Volume of cylinder}$$

$$= \rho \times \pi [R_0^2 - R_i^2] \times L \quad \dots(i)$$

$dm$  = Mass of a circular ring of radius ' $r$ ' width ' $dr$ ' and length  $L$  [Refer to Fig. 5.32]

$$= \text{Density} \times \text{Volume of ring} = \rho \times \text{Area of ring} \times L$$

$$= \rho \times 2\pi r \, dr \times L$$

Now mass moment of inertia of the circular ring about Z-Z axis

$$= \text{Mass of ring} \times (\text{radius})^2$$

$$= (\rho \times 2\pi r \, dr \times L) \times r^2$$

The mass moment of inertia of the hollow circular cylinder will be obtained by integrating the above equation between the limits  $R_i$  to  $R_0$ .

$\therefore$  Mass moment of inertia of the hollow circular cylinder about Z-Z axis is given by,

$$\begin{aligned} (I_m)_{zz} &= \int_{R_i}^{R_0} (\rho \times 2\pi r \, dr \cdot L) r^2 \\ &= \rho \times 2\pi \times L \int_{R_i}^{R_0} r^3 \, dr = \rho \times 2\pi \times L \left[ \frac{r^4}{4} \right]_{R_i}^{R_0} \\ &= \rho \times 2\pi \times L \times \left[ \frac{R_0^4 - R_i^4}{4} \right] \end{aligned}$$

$$\begin{aligned} &= \rho \times 2\pi \times L \times \left[ \frac{R_0^2 - R_i^2}{4} \right] [R_0^2 + R_i^2] \\ &\quad [\because R_0^4 - R_i^4 = (R_0^2 - R_i^2)(R_0^2 + R_i^2)] \\ &= \rho \times \pi [R_0^2 - R_i^2] \times L \times \frac{(R_0^2 + R_i^2)}{2} \\ &= \frac{M(R_0^2 + R_i^2)}{2} \quad [\because \rho \times \pi \times (R_0^2 - R_i^2) = M] \end{aligned}$$

$$\text{Now} \quad (I_m)_{xx} = (I_m)_{yy} = \frac{(I_m)_{zz}}{2} = \frac{M(R_0^2 + R_i^2)}{4}$$

### 5.12.4. Mass Moment of Inertia of a Right Circular Cone of base Radius $R$ , Height $H$ and Mass $M$ about its Axis

Let  $R$  = Radius of the base of the cone,

$H$  = Height of the cone,

$M$  = Mass of the cone

$$= \text{Density} \times \text{Volume of cone} = \rho \times \frac{1}{3} \pi R^2 \times H$$

Consider an elemental plate of thickness  $dy$  and of radius  $x$  at a distance  $y$  from the vertex (as shown in Fig. 5.32 (b)).

$$\text{We have, } \tan \alpha = \frac{x}{y} = \frac{R}{H} \quad \therefore x = \frac{R}{H} \times y$$

Mass of the elemental plate,

$$dm = \rho \times \text{Volume}$$

$$= \rho \times (\pi x^2 \times dy)$$

$$= \rho \times \left[ \pi \frac{R^2 \times y^2}{H^2} \times dy \right] \quad \left[ \because n = \frac{R \times y}{H} \right]$$

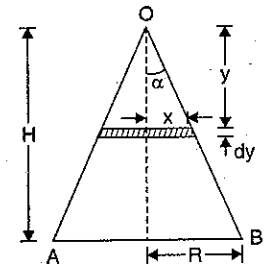

Fig. 5.32 (b)

The mass moment of inertia of the circular elemental plate about the axis of the cone (here axis of the cone is Z-Z axis of the circular elemental plate) is given by equation (5.23) as

$$\begin{aligned} (I_m)_{zz} &= \frac{\text{Mass of plate} \times \text{radius}^2}{2} \\ &= \frac{(dm) \times r^2}{2} = \frac{dm \times x^2}{2} \quad (\because r = x) \\ &= \left[ \rho \times \frac{\pi R^2 y^2}{H^2} \times dy \right] \times \frac{x^2}{2} \quad \left[ \because dm = \rho \times \frac{\pi R y}{H^2} dy \right] \\ &= \frac{\rho \times \pi R^2 y^2}{H^2} \times dy \times \left[ \frac{R^2 y^2}{H^2} \right] \times \frac{1}{2} \quad \left[ \because x = \frac{Ry}{H} \right] \\ &= \frac{\rho \times \pi R^4 \times y^4}{2H^4} dy \end{aligned}$$

Now the total mass moment of inertia of the circular cone will be obtained by integrating the above equation between the limits  $O$  to  $H$ .

$$\begin{aligned} \therefore (I_m)_{zz} &= \int_0^H \frac{\rho \pi R^4 \times y^4}{2H^4} dy = \frac{\rho \pi R^4}{2H^4} \times \left[ \frac{y^5}{5} \right]_0^H \\ &= \frac{\rho \pi R^4}{2H^4} \times \frac{H^5}{5} = \frac{\rho \pi R^4 \times H}{2 \times 5} \end{aligned}$$

But mass of cone,  $M = \frac{\rho \pi R^2 \times H}{3}$

$$\begin{aligned} \therefore (I_m)_{zz} &= \frac{\rho \pi R^2 \times H}{3} \times \frac{R^2 \times 3}{10} \\ &= M \times \frac{3}{10} R^2 = \frac{3}{10} MR^2 \end{aligned} \quad \dots(5.25)$$

### 5.13. PRODUCT OF INERTIA

The Fig. 5.33 shows a body of area  $A$ . Consider a small area  $dA$ . The moment of this area about  $x$ -axis is  $y \cdot dA$ . Now the moment of  $y \cdot dA$  about  $y$ -axis is  $xy \cdot dA$ . Then  $xy \cdot dA$  is known as the product of inertia of area  $dA$

with respect to  $x$ -axis and  $y$ -axis. The integral  $\int xy \cdot dA$  is known as the product of inertia of area  $A$  with respect to  $x$  and  $y$  axes. This product of inertia is represented by  $I_{xy}$ .

$$\therefore I_{xy} = \int xy \cdot dA \quad \dots(5.26)$$

Hence the product of inertia of the plane area is obtained if an elemental area is multiplied by the product of its co-ordinates and is integrated for entire area.

The product of inertia ( $I_{xy}$ ) can also be written mathematically as

$$I_{xy} = \sum x_i y_i A_i = x_1 y_1 A_1 + x_2 y_2 A_2 + \dots \quad \dots(5.26A)$$

where  $x_i, y_i$  = co-ordinates of the C.G. of area  $A_i$ .

**Note.** (i) The product of inertia may be positive, negative or zero depending upon distance  $x$  and  $y$  which could be positive, negative or zero.

(ii) If area is symmetrical with respect to one or both of the axes, the product of inertia will be zero as shown in Fig. 5.34. The total area  $A$  is symmetrical about  $y$ -axis. The small area  $dA$  which is symmetrical about  $y$ -axis has co-ordinates  $(x, y)$  and  $(-x, y)$ . The corresponding product of inertia for small area are  $xy \cdot dA$  and  $-xy \cdot dA$  respectively. Hence product of inertia for total area becomes zero.

(iii) The product of inertia with respect to centroidal axis will also be zero.

**Problem 5.17.** Fig. 5.35 (a) shows a plane area. Determine the product moment of inertia of the given area. All dimensions are in mm.

**Sol.** Divide the given area into two parts. The first part is a rectangle and second part is a right angled triangle. Take  $x$ -axis and  $y$ -axis as shown in the Fig. 5.35 (b). The areas and location of their C.G. are given below :

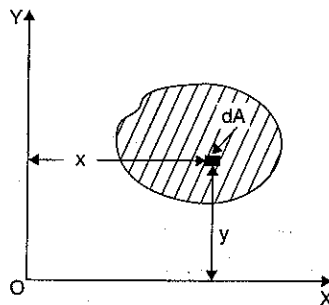

Fig. 5.33

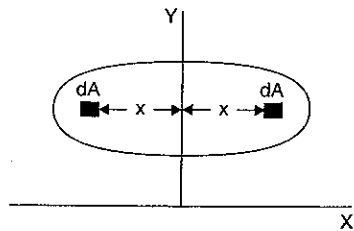

Fig. 5.34

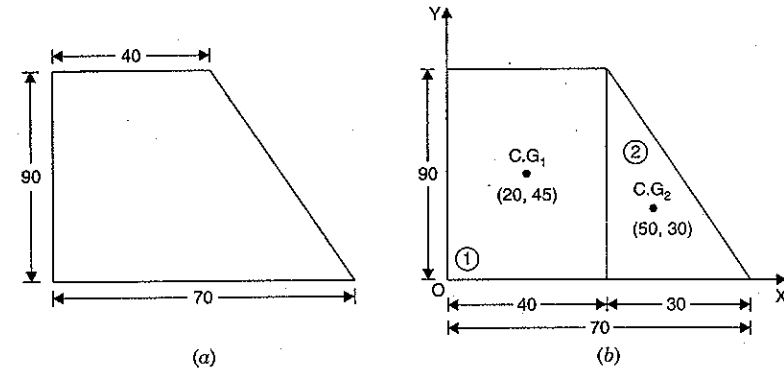

Fig. 5.35

Area of rectangle,  $A_1 = 90 \times 40 = 3600 \text{ mm}^2$ .

The co-ordinates of C.G. of rectangle ① are :  $x_1 = 20 \text{ mm}$ ,  $y_1 = 45 \text{ mm}$ .

Area of triangle,  $A_2 = \frac{90 \times 30}{2} = 1350 \text{ mm}^2$ .

The co-ordinates of C.G. of triangle ② are :

$$x_2 = 40 + \frac{1}{3} \times 30 = 40 + 10 = 50 \text{ mm}; y_2 = \frac{1}{3} \times 90 = 30 \text{ mm}.$$

The product of inertia of given area is given by equation (5.26A) as

$$\begin{aligned} I_{xy} &= x_1 y_1 A_1 + x_2 y_2 A_2 \\ &= A_1 x_1 y_1 + A_2 x_2 y_2 \\ &= 3600 \times 20 \times 45 + 1350 \times 50 \times 30 \\ &= 3240000 + 2025000 = 5265000 \text{ mm}^4. \text{ Ans.} \end{aligned}$$

### 5.14. PRINCIPAL AXES

The principal axes are the axes about which the product of inertia is zero.

The product of inertia ( $I_{xy}$ ) of plane area  $A$  with respect to  $x$  and  $y$  axes is given by equation (5.26) as

$$I_{xy} = \int xy \cdot dA$$

But the moment of inertia of plane area  $A$  about  $x$ -axis [ $I_{xx}$ ] or about  $y$ -axis [ $I_{yy}$ ] is given by

$$I_{xx} = \int y^2 \cdot dA \quad \text{and} \quad I_{yy} = \int x^2 \cdot dA$$

The moment of inertia is always positive but product of inertia may be positive (if both  $x$  and  $y$  are positive), may be negative (if one co-ordinate is positive and other is negative) or may be zero (if any co-ordinate is zero).

Fig. 5.36 (a) shows a body of area  $A$ . Consider a small area  $dA$ . The product of inertia of the total area  $A$  with respect to  $x$  and  $y$ -axes is given as

$$I_{xy} = \int xy \cdot dA \quad \dots(i)$$

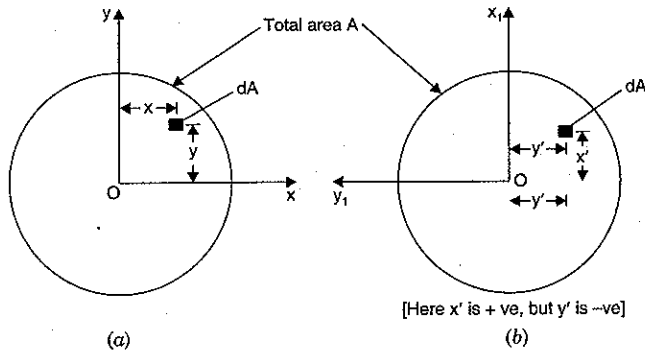

Fig. 5.36

Let now the axes are rotated anticlockwise by  $90^\circ$  as shown in Fig. 5.36 (b) keeping the total area  $A$  in the same position. Let  $x_1$  and  $y_1$  are the new axes. The co-ordinates of the same small area  $dA$  with respect to new axes are  $x'$  and  $y'$ .

Hence the product of inertia of the total area  $A$  with respect to new axes  $x_1$  and  $y_1$  becomes as

$$I_{x_1 y_1} = \int x' y' dA \quad \dots(ii)$$

Now let us find the relation between old and new co-ordinates. From Figs. 5.36 (a) and 5.36 (b), we get

$$x = -y' \text{ and } y = x'$$

$$\text{or } y' = -x \text{ and } x' = y$$

Substituting the values of  $x'$  and  $y'$  in equation (ii), we get

$$I_{x_1 y_1} = \int (y)(-x) dA = - \int xy dA = -I_{xy} \quad (\because \int xy dA = I_{xy})$$

The above result shows that by rotating the axes through  $90^\circ$ , the product of inertia has become negative. This means that the product of inertia which was positive previously has now become negative by rotating the axes through  $90^\circ$ . Hence product of inertia has changed its sign. It is also possible that by rotating the axes through certain angle, the product of inertia will become zero. The new axes about which product of inertia is zero, are known as **principal axes**.

**Note.** (i) The product of inertia is zero about principal axes.

(ii) As the product of inertia is zero about symmetrical axis, hence symmetrical axis is the principal axis of inertia for the area.

(iii) The product of inertia depends upon the orientation of the axes.

### 5.15. PRINCIPAL MOMENTS OF INERTIA

Fig. 5.37 (a) shows a body of area  $A$  with respect to old axes  $(x, y)$  and new axes  $(x_1, y_1)$ . The new axes  $x_1$  and  $y_1$  have been rotated through an angle  $\theta$  in anticlockwise direction. Consider a small area  $dA$ . The co-ordinates of the small area with respect to old axes is  $(x, y)$  whereas with respect to new axes, the co-ordinates are  $x'$  and  $y'$ . The new co-ordinates  $(x', y')$  are expressed in terms of old co-ordinates  $(x, y)$  and angle  $\theta$  as [Refer to Figs. 5.37 (b) and 5.37 (c)]

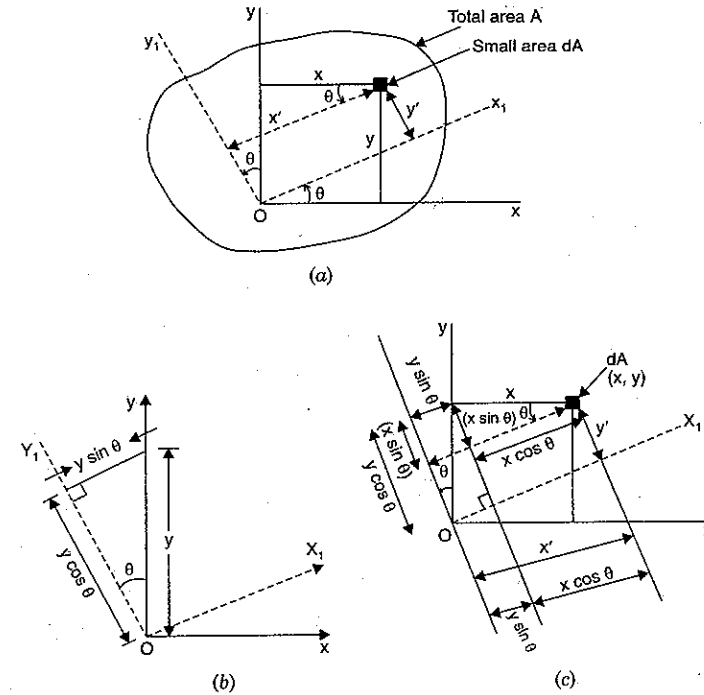

Fig. 5.37

$$x' = y \sin \theta + x \cos \theta \quad \dots(i)$$

and

$$y' = y \cos \theta - x \sin \theta \quad \dots(ii)$$

The moment of inertia and product of inertia of area  $A$  with respect to old axes are

$$I_{xx} = \int y^2 dA, \quad I_{yy} = \int x^2 dA \quad \text{and} \quad I_{xy} = \int xy dA. \quad \dots(5.27)$$

Also the moment of inertia and product of inertia of area  $A$  with respect to new axes will be

$$I_{x_1 x_1} = \int (y')^2 dA, \quad I_{y_1 y_1} = \int (x')^2 dA \quad \text{and} \quad I_{x_1 y_1} = \int x' y' dA$$

Let us substitute the values of  $x'$ ,  $y'$  from equation (i) and (ii) in the above equations, we get

$$I_{x_1 x_1} = \int (y')^2 dA$$

$$= \int (y \cos \theta - x \sin \theta)^2 dA \quad [\because y' = y \cos \theta - x \sin \theta]$$

$$= \int (y^2 \cos^2 \theta + x^2 \sin^2 \theta - 2xy \cos \theta \sin \theta) dA$$

$$= \int y^2 \cos^2 \theta dA + \int x^2 \sin^2 \theta dA - \int 2xy \cos \theta \sin \theta dA$$

$$\begin{aligned}
 &= \cos^2 \theta \int y^2 dA + \sin^2 \theta \int x^2 dA - 2 \cos \theta \sin \theta \int xy dA \\
 &\quad (\because \text{After rotation, the angle } \theta \text{ is constant and hence} \\
 &\quad \cos^2 \theta, \sin^2 \theta \text{ and } 2 \cos \theta \sin \theta \text{ are constant}) \\
 &= (\cos^2 \theta) I_{xx} + (\sin^2 \theta) I_{yy} - (2 \cos \theta \sin \theta) I_{xy} \quad \dots(5.27A) \\
 &\quad (\because \int y^2 dA = I_{xx}, \int x^2 dA = I_{yy} \text{ and } \int xy dA = I_{xy})
 \end{aligned}$$

Similarly,  $I_{y_1 y_1} = \int (x')^2 dA$

$$\begin{aligned}
 &= \int (y \sin \theta + x \cos \theta)^2 dA \quad [\because x' = y \sin \theta + x \cos \theta] \\
 &= \int (y^2 \sin^2 \theta + x^2 \cos^2 \theta + 2xy \sin \theta \cos \theta) dA \\
 &= \int y^2 \sin^2 \theta dA + \int x^2 \cos^2 \theta dA + \int 2xy \sin \theta \cos \theta dA \\
 &= \sin^2 \theta \int y^2 dA + \cos^2 \theta \int x^2 dA + 2 \sin \theta \cos \theta \int xy dA \\
 &\quad (\because \theta \text{ is constant and hence } \sin \theta \text{ and } \cos \theta \text{ are constants}) \\
 &= \sin^2 \theta \cdot I_{xx} + \cos^2 \theta I_{yy} + 2 \sin \theta \cos \theta I_{xy} \quad \dots(5.27B) \\
 &\quad (\because \int y^2 dA = I_{xx}, \int x^2 dA = I_{yy} \text{ and } \int xy dA = I_{xy})
 \end{aligned}$$

Adding equations (5.27A) and (5.27B), we get

$$\begin{aligned}
 I_{x_1 x_1} + I_{y_1 y_1} &= I_{xx} [\sin^2 \theta + \cos^2 \theta] + I_{yy} [\sin^2 \theta + \cos^2 \theta] \\
 &\quad + 2 \sin \theta \cos \theta I_{xy} - 2 \sin \theta \cos \theta I_{xy} \\
 &= I_{xx} + I_{yy} \quad [\because \sin^2 \theta + \cos^2 \theta = 1] \quad \dots(5.27C)
 \end{aligned}$$

The equation (5.27C) shows that sum of moments of inertia about old axes ( $x, y$ ) and new axes ( $x_1, y_1$ ) are same. Hence the sum of moments of inertia of area  $A$  is independent of orientation of axes. Now let us find the value of  $I_{x_1 x_1} - I_{y_1 y_1}$ .

Subtracting equation (5.27B) from equation (5.27A), we get

$$\begin{aligned}
 I_{x_1 x_1} - I_{y_1 y_1} &= \cos^2 \theta I_{xx} + \sin^2 \theta I_{yy} - 2 \cos \theta \sin \theta I_{xy} \\
 &\quad - [\sin^2 \theta I_{xx} + \cos^2 \theta I_{yy} + 2 \cos \theta \sin \theta I_{xy}] \\
 &= I_{xx} (\cos^2 \theta - \sin^2 \theta) + I_{yy} (\sin^2 \theta - \cos^2 \theta) - 4 \cos \theta \sin \theta \cdot I_{xy} \\
 &= I_{xx} (\cos^2 \theta - \sin^2 \theta) - I_{yy} (\cos^2 \theta - \sin^2 \theta) - 4 \cos \theta \sin \theta I_{xy} \\
 &= (I_{xx} - I_{yy}) (\cos^2 \theta - \sin^2 \theta) - 2 \times 2 \cos \theta \sin \theta \times I_{xy} \\
 &= (I_{xx} - I_{yy}) \cos 2\theta - 2 I_{xy} \sin^2 \theta \quad \dots(5.27D) \\
 &\quad (\because \cos^2 \theta = \frac{1 + \cos 2\theta}{2}, \sin^2 \theta = \frac{1 - \cos 2\theta}{2})
 \end{aligned}$$

$$\therefore \cos^2 \theta - \sin^2 \theta = \cos 2\theta \text{ and } 2 \sin \theta \cos \theta = \sin 2\theta$$

Now let us find the values of  $I_{x_1 x_1}$  and  $I_{y_1 y_1}$  in terms of  $I_{xx}, I_{yy}$  and  $\theta$ .

Adding equations (5.27C) and (5.27D), we get

$$2I_{x_1 x_1} = [I_{xx} + I_{yy}] + [(I_{xx} - I_{yy}) \cos 2\theta - 2I_{xy} \sin 2\theta]$$

or 
$$I_{x_1 x_1} = \frac{(I_{xx} + I_{yy})}{2} + \frac{(I_{xx} - I_{yy})}{2} \cos 2\theta - I_{xy} \sin 2\theta \quad \dots(5.27E)$$

To find the values of  $I_{y_1 y_1}$ , subtract equation (5.27D) from (5.27C). Now subtracting equation (5.27D) from equation (5.27C), we get

$$\begin{aligned}
 2I_{y_1 y_1} &= (I_{xx} + I_{yy}) - [(I_{xx} - I_{yy}) \cos 2\theta - 2I_{xy} \sin 2\theta] \\
 \therefore I_{y_1 y_1} &= \frac{(I_{xx} + I_{yy})}{2} - \frac{(I_{xx} - I_{yy})}{2} \cos 2\theta + I_{xy} \sin 2\theta \quad \dots(5.27F)
 \end{aligned}$$

### Product of Inertia about New Axes

Let us now find the value of  $I_{x_1 y_1}$  in terms of  $I_{xy}$  and angle  $\theta$ .

We know that 
$$I_{x_1 y_1} = \int (x')(y') dA$$

Substituting the values of  $x'$  and  $y'$ , we get

$$\begin{aligned}
 I_{x_1 y_1} &= \int (y \sin \theta + x \cos \theta)(y \cos \theta - x \sin \theta) dA \\
 &\quad (\because x' = y \sin \theta + x \cos \theta \text{ and } y' = y \cos \theta - x \sin \theta)
 \end{aligned}$$

or 
$$\begin{aligned}
 I_{x_1 y_1} &= \int (y^2 \sin \theta \cos \theta - xy \sin^2 \theta + xy \cos^2 \theta - x^2 \cos \theta \sin \theta) dA \\
 &= \int y^2 \sin \theta \cos \theta dA - \int xy \sin^2 \theta dA + \int xy \cos^2 \theta dA - \int x^2 \cos \theta \sin \theta dA \\
 &= \sin \theta \cos \theta \int y^2 dA - \sin^2 \theta \int xy dA + \cos^2 \theta \int xy dA - \cos \theta \sin \theta \int x^2 dA \\
 &\quad (\because \theta \text{ is constant and hence } \sin \theta, \cos \theta \text{ are constants})
 \end{aligned}$$

$$\begin{aligned}
 I_{x_1 y_1} &= \frac{2 \sin \theta \cos \theta}{2} \int y^2 dA - \sin^2 \theta I_{xy} + \cos^2 \theta I_{xy} - \frac{2 \cos \theta \sin \theta}{2} \int x^2 dA \\
 &\quad (\because \int xy dA = I_{xy}) \\
 &= \frac{\sin 2\theta}{2} \cdot I_{xx} + I_{xy} (\cos^2 \theta - \sin^2 \theta) - \frac{\sin 2\theta}{2} I_{yy} \\
 &\quad (\because \int y^2 dA = I_{xx}, \int x^2 dA = I_{yy})
 \end{aligned}$$

$$\begin{aligned}
 &= \frac{I_{xx}}{2} \sin 2\theta + I_{xy} (\cos^2 \theta - \sin^2 \theta) - \frac{I_{yy}}{2} \sin 2\theta \\
 &= \frac{(I_{xx} - I_{yy})}{2} \sin 2\theta + I_{xy} (\cos^2 \theta - \sin^2 \theta) \\
 &= \frac{(I_{xx} - I_{yy})}{2} \sin 2\theta + I_{xy} \cos 2\theta \quad \dots(5.27G)
 \end{aligned}$$

$$(\because \cos^2 \theta - \sin^2 \theta = \cos 2\theta)$$

### Direction of Principal Axes

We have already defined the principal axes. Principal axes are the axes about which the product of inertia is zero. Now the new axes ( $x_1, y_1$ ) will become principal axes if the product of inertia given by equation (5.27G) is zero (i.e.,  $I_{x_1 y_1} = 0$ ).

∴ For principal axes,  $I_{x_1y_1} = 0$

$$\text{or } \frac{(I_{xx} - I_{yy})}{2} \sin 2\theta + I_{xy} \cos 2\theta = 0$$

$$\text{or } \frac{(I_{xx} - I_{yy})}{2} \sin 2\theta = -I_{xy} \cos 2\theta$$

$$\text{or } \frac{\sin 2\theta}{\cos 2\theta} = \frac{-2I_{xy}}{I_{xx} - I_{yy}} = \frac{2I_{xy}}{I_{yy} - I_{xx}}$$

$$\text{or } \tan 2\theta = \frac{2I_{xy}}{I_{yy} - I_{xx}} \quad \dots(5.27H)$$

The above equation will give the two values of  $2\theta$  or  $\theta$ . These two values of  $\theta$  will differ by  $90^\circ$ . By substituting the values of  $\theta$  in equations (5.27E) and (5.27F), the values of **principal moments of inertia** ( $I_{x_1x_1}$  and  $I_{y_1y_1}$ ) can be obtained. If from equation (5.27H), the values of  $\sin 2\theta$  and  $\cos 2\theta$  in terms of  $I_{xy}$ ,  $I_{xx}$  and  $I_{yy}$  are substituted in equation (5.27E), we get

$$I_{x_1x_1} = \frac{I_{xx} + I_{yy}}{2} \pm \sqrt{\frac{(I_{xx} - I_{yy})^2}{4} + I_{xy}^2}$$

These are the values of principal moment of inertia.

**Problem 5.18.** For the section shown in Fig. 5.38 (a) determine :

- Moment of inertia about its centroid along (x, y) axis.
- Moment of inertia about new axes which is turned through an angle of  $30^\circ$  anticlockwise to the old axis.
- Principal moments of inertia about its centroid.

All dimensions are in cm.

**Sol. Given :**

The Fig. 5.38 (a) shows the given section. It is symmetrical about x-axis. The C.G. of the section lies at O (origin of the axes). To find moment of inertia of the given section, it is divided into three rectangles as shown in Fig. 5.38 (b). First the moment of inertia of each rectangle about its centroid is calculated. Then by using parallel axis theorem, the moment of inertia of the given section about its centroid is obtained.

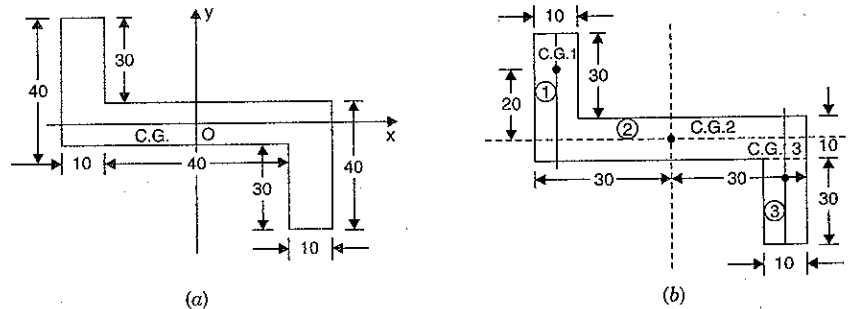

Fig. 5.38

(a) Consider rectangle (1)

The C.G. of rectangle (1) is at a distance of 20 cm from x-axis and at a distance of 25 cm from y-axis.

$$(I_{xx})_1 = (I_G)_{1x} + A_1(k_{1x})^2$$

where  $(I_{xx})_1$  = M.O.I. of rectangle (1) about x-axis passing through the centroid of the given figure of the given section.

$(I_G)_{1x}$  = M.O.I. of rectangle (1) about an axis passing through C.G. of rectangle (1) and parallel to

$$\begin{aligned} x\text{-axis} &= \frac{bd^3}{12} \\ &= \frac{30 \times 10^3}{12} \quad (\text{Here } b = 10 \text{ and } d = 30) \\ &= 2.25 \times 10^4 \text{ cm}^4 \end{aligned}$$

$$A_1 = \text{Area of rectangle (1)} = 10 \times 30 = 300$$

$$\begin{aligned} (k_{1x}) &= \text{Distance of C.G. of rectangle (1) from } x\text{-axis} \\ &= 20 \end{aligned}$$

Substituting the above values in equation (1), we get

$$\begin{aligned} (I_{xx})_1 &= 2.25 \times 10^4 + 300 \times 20^2 \\ &= 2.25 \times 10^4 + 12 \times 10^4 \\ &= 14.25 \times 10^4 \text{ cm}^4 \quad \dots(A) \end{aligned}$$

Similarly, the M.O.I. of rectangle (1) about y-axis passing through the centroid of the given figure is given by,

$$(I_{yy})_1 = (I_G)_{1y} + A_1(k_{1y})^2$$

$$\text{where } (I_G)_{1y} = \frac{bd^3}{12} = \frac{30 \times 10^3}{12} = 0.25 \times 10^4 \text{ cm}^4$$

$$(k_{1y}) = \text{Distance of C.G. of rectangle (1) from } y\text{-axis} = 25$$

$$\begin{aligned} (I_{yy})_1 &= 0.25 \times 10^4 + 300 \times 25^2 \\ &= 0.25 \times 10^4 + 18.75 \times 10^4 \\ &= 19 \times 10^4 \text{ cm}^4 \quad \dots(B) \end{aligned} \quad (\because A_1 = 300)$$

(b) Consider rectangle (2)

The C.G. of this rectangle coincides with the C.G. of the given section. Hence

$$(I_{xx})_2 = \frac{bd^3}{12} = \frac{60 \times 10^3}{12} = 0.5 \times 10^4 \text{ cm}^4 \quad \dots(C)$$

$$\text{and } (I_{yy})_2 = \frac{10 \times 60^3}{12} = 18 \times 10^4 \text{ cm}^4 \quad \dots(D)$$

(c) Consider rectangle (3)

The C.G. of rectangle (3) is at a distance of 20 cm from x-axis and at a distance of 25 cm from y-axis. Hence  $k_{3x} = 20$  cm and  $k_{3y} = 25$  cm.

$$\text{Now } (I_{xx})_3 = (I_G)_{3x} + A_3(k_{3x})^2$$

$$= \frac{10 \times 30^3}{12} + (10 \times 30)(20)^2 = 2.25 \times 10^4 + 12 \times 10^4 = 14.25 \times 10^4 \text{ cm}^4$$



and 
$$(I_{yy})_3 = (I_G)_{3y} + A_3(k_3y)^2$$

$$= \frac{30 \times 10^3}{12} + 300 \times 25^2 = 0.25 \times 10^4 + 18.75 \times 10^4 = 19 \times 10^4 \text{ cm}^4.$$

(i) **Moment of inertia of complete section about its centroid**

$$I_{xx} = (I_{xx})_1 + (I_{xx})_2 + (I_{xx})_3$$

$$= 14.25 \times 10^4 + 0.5 \times 10^4 + 14.25 \times 10^4 \text{ cm}^4$$

$$= 29 \times 10^4 \text{ cm}^4. \text{ Ans.}$$

and 
$$I_{yy} = (I_{yy})_1 + (I_{yy})_2 + (I_{yy})_3$$

$$= 19 \times 10^4 + 18 \times 10^4 + 19 \times 10^4$$

$$= 56 \times 10^4 \text{ cm}^4. \text{ Ans.}$$

(ii) **Moment of inertia of complete section about new axes which is turned through an angle of 30° anticlockwise.**

Here  $\theta = 30^\circ$ .

Let us first calculate the product of inertia of whole area about old axes  $x, y$ .

(a) **Consider rectangle (1)**

$$A_1 = 10 \times 30 = 300.$$

The C.G. of rectangle (1) is at a distance of 20 cm above  $x$ -axis and at a distance of 25 cm from  $y$ -axis. Hence co-ordinates of this C.G. are

$$x_1 = -25 \text{ cm and } y_1 = 20 \text{ cm.}$$

(b) **For rectangle (2)**

$A_2 = 10 \times 60 = 600 \text{ cm}^2$ . The C.G. of rectangle (2) lies on the origin ( $O$ ). Hence  $x_2 = 0$  and  $y_2 = 0$ .

(c) **For rectangle (3)**

$$A_3 = 10 \times 30 = 300 \text{ cm}^2$$

The C.G. of rectangle (3) is at a distance of 20 cm below  $x$ -axis and at a distance of 25 cm from  $y$ -axis.

Hence co-ordinate of this C.G. are :  $x_3 = 25 \text{ cm}$  and  $y_3 = (-20 \text{ cm})$ .

The product of inertia ( $I_{xy}$ ) of the whole figure is given by equation (5.26A) as

$$I_{xy} = A_1x_1y_1 + A_2x_2y_2 + A_3x_3y_3$$

$$= 300 \times (-25) \times 20 + 600 \times 0 \times 0 + 300 \times 25 \times (-20)$$

$$= -15 \times 10^4 + 0 + (-15 \times 10^4)$$

$$= -30 \times 10^4 \text{ cm}^4$$

Now the moment of inertia of the complete section about the new axes ( $x_1, y_1$ ) can be obtained from equations (5.27E) and (5.27F) as

$$I_{x_1x_1} = \frac{(I_{xx} + I_{yy})}{2} + \frac{(I_{xx} - I_{yy})}{2} \cos 2\theta - I_{xy} \sin 2\theta$$

where  $I_{xx} = 29 \times 10^4 \text{ cm}^4$ ,  $I_{yy} = 56 \times 10^4 \text{ cm}^4$ ,  
 $I_{xy} = -30 \times 10^4 \text{ cm}^4$  and  $\theta = 30^\circ$

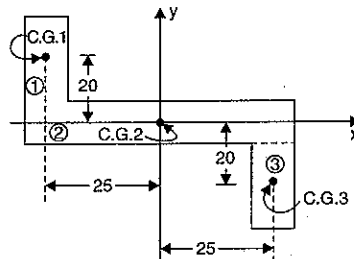

Fig. 5.38 (c)

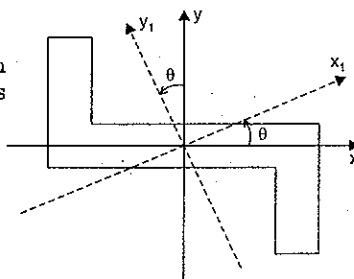

Fig. 5.38 (d)

$$\therefore I_{x_1x_1} = \frac{29 \times 10^4 + 56 \times 10^4}{2} + \frac{29 \times 10^4 - 56 \times 10^4}{2} \cos 60^\circ - (-30 \times 10^4) \sin 60^\circ$$

$$= 42.5 \times 10^4 - 13.5 \times 10^4 \times \frac{1}{2} + 30 \times 10^4 \times 0.866$$

$$= 35.75 \times 10^4 + 26 \times 10^4 = 61.75 \times 10^4 \text{ cm}^4. \text{ Ans.}$$

and 
$$I_{y_1y_1} = \frac{I_{xx} + I_{yy}}{2} - \frac{I_{xx} - I_{yy}}{2} \cos \theta + I_{xy} \sin 2\theta$$

$$= \frac{29 \times 10^4 + 56 \times 10^4}{2} - \frac{29 \times 10^4 - 56 \times 10^4}{2} \cos 60^\circ + (-30 \times 10^4) \sin 60^\circ$$

$$= 42.5 \times 10^4 + 6.75 \times 10^4 - 26 \times 10^4 = 23.25 \times 10^4 \text{ cm}^4. \text{ Ans.}$$

(iii) **Principal moments of inertia about the centroid**

The principal moments of inertia are the moments of inertia about the principal axes.

The direction of principal axes is given by equation (5.27H) as

$$\tan 2\theta = \frac{2I_{xy}}{I_{yy} - I_{xx}}$$

$$= \frac{2 \times (-30 \times 10^4)}{56 \times 10^4 - 29 \times 10^4}$$

$$= \frac{-60 \times 10^4}{27 \times 10^4} = -2.222$$

As  $2\theta$  is negative, hence it lies in 2nd and 4th quadrant.

$$\therefore 2\theta = \tan^{-1}(-2.222)$$

$$= -65.77^\circ \text{ and } 114.23^\circ$$

or 
$$\theta = -32.88^\circ \text{ and } 57.12^\circ$$

The +ve angle is taken anti-clock and -ve angle is taken clockwise to the existing axes  $x$  and  $y$ . The principal axes are shown as  $x_1$  and  $y_1$  in Fig. 7.38 (e). The moment of inertia along these axes is the principal moment of inertia. Hence by substituting  $\theta = -32.88^\circ$  and  $57.12^\circ$ , in equations (5.27E) and (5.27F), we get principal moment of inertia.

$$\therefore \left( I_{x_1x_1} \right)_{\max} = \frac{I_{xx} + I_{yy}}{2} + \frac{I_{xx} - I_{yy}}{2} \cos 2\theta - I_{xy} \sin 2\theta$$

$$= \frac{29 \times 10^4 + 56 \times 10^4}{2} + \frac{29 \times 10^4 - 56 \times 10^4}{2} \times \cos (-2 \times 32.88) - (-30 \times 10^4) \sin (-2 \times 32.88)$$

[  $\because \theta = -32.88^\circ$  ]

$$= 42.5 \times 10^4 - 13.5 \times 10^4 \times 0.41 + 30 \times 10^4 \times (-0.912)$$

$$= 42.5 \times 10^4 - 5.535 \times 10^4 - 27.36 \times 10^4$$

$$= 9.605 \times 10^4 \text{ cm}^4$$

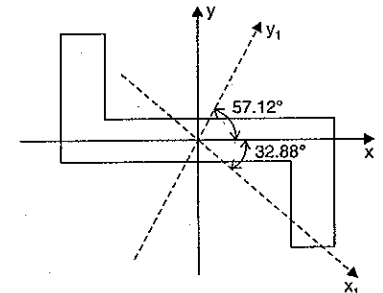

Fig. 5.38 (e)

$$\text{and } \left( I_{y_1 y_1} \right)_{\min.} = \frac{I_{xx} + I_{yy}}{2} - \frac{I_{xx} - I_{yy}}{2} \cos 2\theta + I_{yy} \sin 2\theta$$

$$= 42.5 \times 10^4 + 5.535 \times 10^4 + 27.36 \times 10^4 = 75.395 \times 10^4 \text{ cm}^4$$

Hence principal moment of inertia are

$$I_{\max.} = 75.395 \times 10^4 \text{ cm}^4. \text{ Ans.}$$

$$I_{\min.} = 9.605 \times 10^4 \text{ cm}^4. \text{ Ans.}$$

#### Alternate Method

The principal moments of inertia can also be obtained by

$$I_{\max.} = \frac{I_{xx} + I_{yy}}{2} \pm \sqrt{\frac{(I_{xx} - I_{yy})^2}{4} + I_{xy}^2}$$

$$= \frac{29 \times 10^4 + 56 \times 10^4}{2} \pm \sqrt{\frac{(29 \times 10^4 - 56 \times 10^4)^2}{4} + (-30 \times 10^4)^2}$$

$$= 42.5 \times 10^4 \pm \sqrt{(-13.5 \times 10^4)^2 + (-30 \times 10^4)^2}$$

$$= 42.5 \times 10^4 \pm 10^4 \times 32.89$$

$$= (42.5 + 32.89) \times 10^4 \text{ and } (42.5 - 32.89) \times 10^4$$

$$= 75.39 \times 10^4 \text{ and } 9.61 \times 10^4 \text{ cm}^4$$

$\therefore I_{\max.} = 75.39 \times 10^4 \text{ cm}^4$  and  $I_{\min.} = 9.61 \times 10^4 \text{ cm}^4$   
Now  $I_{\max.}$  and  $I_{\min.}$  are the required principal moment of inertia. **Ans.**

#### HIGHLIGHTS

1. The point, through which the whole weight of the body acts, is known as centre of gravity.
2. The point, at which the total area of a plane figure is assumed to be concentrated, is known as centroid of that area. The centroid and centre of gravity are at the same point.
3. The centre of gravity of a uniform rod lies at its middle point.
4. The C.G. of a triangle lies at a point where the three medians of a triangle meet.
5. The C.G. of a parallelogram or a rectangle is at a point where its diagonal meet each other.
6. The C.G. of a circle lies at its centre.
7. The C.G. of a body consisting of different areas is given by

$$\bar{x} = \frac{a_1 x_1 + a_2 x_2 + a_3 x_3 + \dots}{a_1 + a_2 + a_3 + \dots} \quad \text{and} \quad \bar{y} = \frac{a_1 y_1 + a_2 y_2 + a_3 y_3 + \dots}{a_1 + a_2 + a_3 + \dots}$$

where  $\bar{x}$  and  $\bar{y}$  = Co-ordinates of the C.G. of the body from axis of reference

$a_1, a_2, a_3, \dots$  = Different areas of the sections of the body

$x_1, x_2, x_3, \dots$  = Distances of the C.G. of the areas  $a_1, a_2, a_3, \dots$  from Y-axis

$y_1, y_2, y_3, \dots$  = Distances of the C.G. of the areas  $a_1, a_2, a_3, \dots$  from X-axis.

8. If a given section is symmetrical about X-X axis or Y-Y axis, the C.G. of the section will lie on the axis symmetry.
9. The moment of inertia of an area (or mass) about an axis is the product of area (or mass) and square of the distance of the C.G. of the area (or mass) from that axis. It is represented by  $I$ .

10. Radius of gyration of a body (or a given lamina) is the distance from an axis of reference where the whole mass (or area) of the given body is assumed to be concentrated so as not to alter the moment of inertia about the given axis. It is represented by  $k$ . Mathematically,  $k = \sqrt{\frac{I}{A}}$ .

11. According to theorem of perpendicular axis  $I_{ZZ} = I_{XX} + I_{YY}$  where  $I_{XX}$  and  $I_{YY}$  = Moment of inertia of a plane section about two mutually perpendicular axes X-X and Y-Y in the plane of the section,  $I_{ZZ}$  = Moment of inertia of the section perpendicular to the plane and passing through the intersection of X-X and Y-Y axes.

12. According to the theorem of parallel axis  $I_{AB} = I_G + Ah^2$ , where

$I_G$  = Moment of inertia of a given area about an axis passing through C.G. of the area

$I_{AB}$  = Moment of inertia of the given area about an axis AB, which is parallel to the axis passing through G

$h$  = Distance between the axis passing through G and axis AB

$A$  = Area of the section.

13. Moment of inertia of a rectangular section :

(i) about an horizontal axis passing through C.G. =  $\frac{bd^3}{12}$

(ii) about an horizontal axis passing through base =  $\frac{bd^3}{3}$

14. Moment of inertia of a circular section =  $\frac{\pi D^4}{64}$

15. Moment of inertia of a triangular section :

(i) about the base =  $\frac{bh^3}{12}$

(ii) about an axis passing through C.G. and parallel to the base =  $\frac{bh^3}{36}$

where  $b$  = Base width, and  $h$  = Height of the triangle.

16. The C.G. of an area by integration method is given by

$$\bar{x} = \frac{\int x^* dA}{\int dA} \quad \text{and} \quad \bar{y} = \frac{\int y^* dA}{\int dA}$$

where  $x^*$  = Distance of C.G. of area  $dA$  from y-axis

$y^*$  = Distance of C.G. of area  $dA$  from x-axis.

17. The C.G. of a straight or curved line is given by

$$\bar{x} = \frac{\int x^* dL}{\int dL} \quad \text{and} \quad \bar{y} = \frac{\int y^* dL}{\int dL}$$

#### EXERCISE 5

##### (A) Theoretical Questions

1. Define centre of gravity and centroid.
2. Derive an expression for the centre of gravity of a plane area using method of moments.

3. What do you understand by axes of reference ?
4. Define the terms : moment of inertia and radius of gyration.
5. State the theorem of perpendicular axis. How will you prove this theorem ?
6. State and prove the theorem of parallel axis.
7. Find an expression for the moment of inertia of a rectangular section :
  - (i) about an horizontal axis passing through the C.G. of the rectangular section, and
  - (ii) about an horizontal axis passing through the base of the rectangular section.

(AMIE Summer, 1985)

8. Prove that the moment of inertia of a circular section about an horizontal axis (in the plane of the circular section) and passing through the C.G. of the section is given by  $\frac{\pi D^4}{64}$ .

9. Prove that moment of inertia of a triangular section about the base of the section

$$= \frac{bh^3}{12}$$

where  $b$  = Base of triangular section, and $h$  = Height of triangular section.

10. Derive an expression for the moment of inertia of a triangular section about an axis passing through the C.G. of the section and parallel to the base.
11. Show that  $I_O = I_G + Ah^2$ , where  $I_G$  is the moment of inertia of a lamina about an axis through its centroid and lying in its plane and  $h$  is the distance from the centroid to a parallel axis in the same plane about which its moment of inertia is  $I_O$ ,  $A$  being the area of the lamina.
12. State and prove the parallel axes theorem on moment of inertia for a plane area.
13. Prove that the moment of area of any plane figure about a line passing through its centroid is zero.
14. Show that the product of inertia of an area about two mutually perpendicular axis is zero, if the area is symmetrical about one of these axis. (U.P. Tech. University, 2002-2003)
15. Determine an expression for mass moment of inertia of hollow steel cylinder of mass  $M$ , outer radius  $R_o$ , inner radius  $R_i$  and length  $L$  about its axis. The hole in the cylinder is concentric. (U.P. Tech. University, 2002-2003)
16. Derive an expression for mass moment of inertia of a right circular cone of base radius  $R$ , height  $H$  and mass  $M$  about its axis. (U.P. Tech. University, 2001-2002)

**(B) Numerical Problems**

1. Find the centre of gravity of the T-section shown in Fig. 5.39.

[Ans. 8.272 cm]

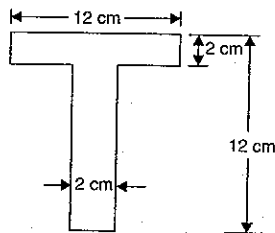

Fig. 5.39

2. Find the centre of gravity of the I-section shown in Fig. 5.40.

[Ans. 6.44 cm]

[Hint.  $a_1 = 8 \times 2 = 16 \text{ cm}^2$ ,  $a_2 = 12 \times 2 = 24 \text{ cm}^2$ , $a_3 = 16 \times 2 = 32$ ;  $y_1 = 2 + 12 + 1 = 15$ , $y_2 = 2 + 6 = 8$ ,  $y_3 = 1$ 

$$\begin{aligned} \bar{y} &= \frac{a_1 y_1 + a_2 y_2 + a_3 y_3}{a_1 + a_2 + a_3} \\ &= \frac{16 \times 15 + 24 \times 8 + 32 \times 1}{16 + 24 + 32} \\ &= \frac{240 + 192 + 32}{72} = \frac{464}{72} = 6.44 \text{ cm.} \end{aligned}$$

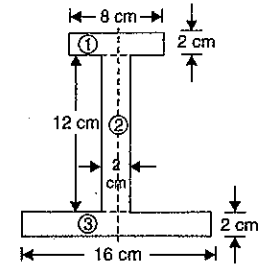

Fig. 5.40

3. (a) Find the centre of gravity of the L-section shown in Fig. 5.41. [Ans.  $\bar{x} = 1.857$ ,  $\bar{y} = 3.857$ ]

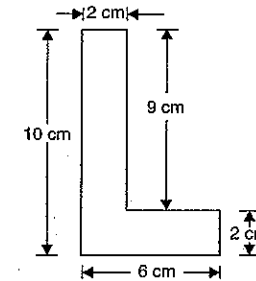

Fig. 5.41

- (b) Find the moment of inertia of ISA 100 × 75 × 6 about the centroidal  $XX$  and  $YY$  axis, shown in Fig. 5.41 (a). (U.P. Tech. University, 2001-2002)

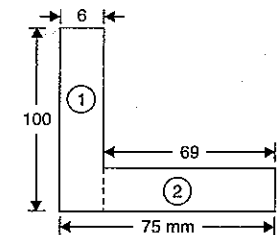

Fig. 5.41 (a)

[Hint. Locate first  $\bar{x}$  and first  $\bar{y}$ 

$$a_1 = 100 \times 6 = 600 \text{ mm}^2, x_1 = 3 \text{ mm}, y_1 = 50$$

$$a_2 = 69 \times 6 = 414 \text{ mm}^2, x_2 = 6 + \frac{69}{2} = 40.5$$

$$y_2 = 3 \text{ mm}$$

$$\bar{x} = \frac{a_1 x_1 + a_2 x_2}{a_1 + a_2} = \frac{600 \times 3 + 414 \times 40.5}{600 + 414} = 18.31 \text{ mm}$$

$$\bar{y} = \frac{a_1 y_1 + a_2 y_2}{a_1 + a_2} = \frac{600 \times 50 + 414 \times 3}{600 + 414} = 30.81 \text{ mm}$$

Now find the moment of inertia about centroidal X-X axis :

$$I_{XX1} = (I_{G_1})_x + a_1 h_1^2$$

$$= \frac{6 \times 100^3}{12} + 600 \times (y_1 - \bar{y})^2 = \frac{6 \times 100^3}{12} + 600(50 - 30.81)^2$$

$$= 720.95 \times 10^3 \text{ mm}^4.$$

$$I_{XX2} = (I_{G_2})_x + a_2 h_2^2 = \frac{69 \times 6^3}{12} + 414(y_2 - \bar{y})^2$$

$$= \frac{69 \times 6^3}{12} + 414(3 - 30.81)^2 = 321.428 \times 10^3$$

$$\therefore I_{XX} = I_{XX1} + I_{XX2} = 720.95 \times 10^3 + 321.428 \times 10^3 = 1042.378 \times 10^3 \text{ mm}^4. \text{ Ans.}$$

To find M.O.I. about centroidal axis Y-Y

$$I_{YY1} = (I_{G_1})_y + a_1(x_1 - \bar{x})^2 = \frac{100 \times 6^3}{12} + 600(3 - 18.31)^2 = 142.437 \times 10^3 \text{ mm}^4$$

$$I_{YY2} = (I_{G_2})_y + a_2(x_2 - \bar{x})^2 = \frac{6 \times 69^3}{12} + 414(40.5 - 18.31)^2 = 368.1 \times 10^3 \text{ mm}^4$$

$$\therefore I_{YY} = I_{YY1} + I_{YY2} = (142.437 + 368.1) \times 10^3 \text{ mm}^4 = 510.537 \times 10^3 \text{ mm}^4. \text{ Ans.}]$$

4. From a rectangular lamina ABCD 10 cm × 14 cm a rectangular hole of 3 cm × 5 cm is cut as shown in Fig. 5.42. Find the centre of gravity of the remainder lamina.

[Ans.  $\bar{x} = 4.7 \text{ cm}$ ,  $\bar{y} = 6.444 \text{ cm}$ ]

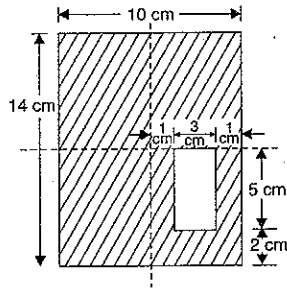

Fig. 5.42

5. For the T-section shown in Fig. 5.39, determine the moment of inertia of the section about the horizontal and vertical axes, passing through the centre of gravity of the section.

[Ans.  $567.38 \text{ cm}^4$ ,  $294.67 \text{ cm}^4$ ]

6. For the I-section shown in Fig. 5.40, find the moment of inertia about the centroidal axis X-X perpendicular to the web.

[Ans.  $2481.76 \text{ cm}^4$ ]

7. Locate the C.G. of the area shown in Fig. 5.43 with respect to co-ordinate axes. All dimensions are in mm.

[Hint.  $a_1 = 10 \times 30 = 300 \text{ mm}^2$ ,  $x_1 = 5 \text{ mm}$ ,  $y_1 = 15$ .

$a_2 = 40 \times 10 = 400 \text{ mm}^2$ ,  $x_2 = 10 + 20 = 30 \text{ mm}$ ,

$y_2 = 5 \text{ mm}$

$a_3 = 10 \times 20 = 200 \text{ mm}^2$ ,  $x_3 = 5 \text{ mm}$ ,

$y_3 = -10 \text{ mm}$

$$a_4 = 10 \times 10 = 100 \text{ mm}^2, x_4 = 45 \text{ mm},$$

$$y_4 = 10 + 5 = 15 \text{ mm}$$

$$\bar{x} = \frac{a_1 x_1 + a_2 x_2 + a_3 x_3 + a_4 x_4}{a_1 + a_2 + a_3 + a_4}$$

$$= \frac{1500 + 12000 + 1000 + 4500}{1000}$$

$$= 1.5 + 12 + 1 + 4.5 = 19 \text{ mm. Ans.}$$

$$\bar{y} = \frac{a_1 y_1 + a_2 y_2 + a_3 y_3 + a_4 y_4}{a_1 + a_2 + a_3 + a_4}$$

$$= \frac{4500 + 2000 - 2000 + 1500}{1000}$$

$$= 4.5 + 2 - 2 + 1.5 = 6 \text{ mm. Ans.}]$$

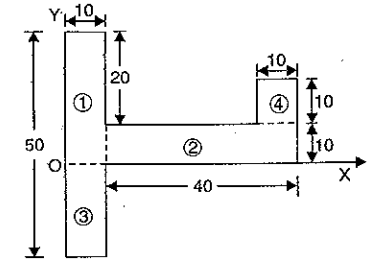

Fig. 5.43

8. A thin homogeneous wire is bent into a triangular shape ABC such that AB = 240 mm, BC = 260 mm and AC = 100 mm. Locate the C.G. of the wire with respect to co-ordinate axes. Angle at A is right angle.

[Hint. First determine angles  $\alpha$  and  $\beta$ . Use sine rule

$$\frac{BC}{\sin 90^\circ} = \frac{AC}{\sin \alpha} = \frac{AB}{\sin \beta}$$

$$\therefore \sin \alpha = \frac{AC \sin 90^\circ}{BC} = \frac{100}{260}$$

$$\therefore \alpha = 22.62^\circ. \text{ Also } \sin \beta = \frac{AB}{BC} \times \sin 90^\circ = \frac{240}{260}$$

$$\therefore \beta = 67.38^\circ$$

Using equation 5.2 (c) and 5.2 (d)

$$\bar{x} = \frac{L_1 x_1 + L_2 x_2 + L_3 x_3}{L_1 + L_2 + L_3}, \text{ where } L_1 = AB = 240,$$

$x_1 =$  distance of C.G. of AB from y-axis

$$= \frac{240}{2} \times \cos \alpha = 120 \times \cos 22.62^\circ = 110.77 \text{ mm}$$

$L_2 = BC = 260 \text{ mm}$ ,  $x_2 =$  Distance of C.G. of BC from y-axis = 130

$L_3 = AC = 100 \text{ mm}$ ,  $x_3 =$  Distance of C.G. of AC from y-axis

$$= BD + \frac{100}{2} \cos \beta = 240 \cos \alpha + 50 \cos \beta$$

$$= 240 \times \cos 22.62^\circ + 50 \cos 67.38^\circ = 240.77$$

$$\bar{x} = \frac{240 \times 110.77 + 260 \times 130 + 100 \times 240.77}{240 + 260 + 100} = 140.77 \text{ mm. Ans.}$$

$$\bar{y} = \frac{L_1 y_1 + L_2 y_2 + L_3 y_3}{L_1 + L_2 + L_3}, \text{ where } y_1 = \frac{240}{2} \sin \alpha = 120 \times \sin 22.62^\circ = 46.154$$

$$y_2 = 0, y_3 = \frac{100}{2} \sin \beta = 50 \sin 67.38^\circ = 48.154$$

$$\bar{y} = \frac{240 \times 46.154 + 260 \times 0 + 100 \times 48.154}{600}$$

$$= 26.154 \text{ mm. Ans.}]$$

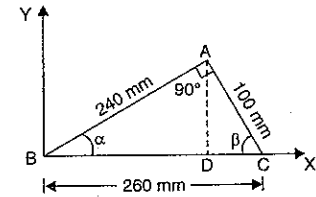

Fig. 5.44

9. Determine the C.G. of the uniform plane lamina shown in Fig. 5.45. All dimensions are in cm. [Hint. The Fig is symmetrical about y-y axis.]

$$\bar{y} = \frac{a_1 y_1 + a_2 y_2 + a_3 y_3 + a_4 y_4}{a_1 + a_2 + a_3 + a_4}$$

$$\text{where } a_1 = 40 \times 30 = 1200 \text{ cm}^2, y_1 = \frac{30}{2} = 15 \text{ cm}$$

$$a_2 = 30 \times 20 = 600 \text{ cm}^2, y_2 = 30 + \frac{30}{2} = 45 \text{ cm}$$

$$a_3 = -\frac{\pi \times 10^2}{2} = -50\pi, y_3 = \frac{4r}{3\pi} = \frac{4 \times 10}{3\pi} = \frac{40}{3\pi}$$

$$a_4 = -\frac{20 \times 10}{2} = -100, y_4 = 60 - \frac{10}{3} = \frac{170}{3}$$

$$\bar{y} = \frac{1200 \times 15 + 600 \times 45 - 50\pi \times \frac{40}{3\pi} - 100 \times \frac{170}{3}}{1200 + 600 - 50\pi - 100}$$

$$= \frac{18000 + 27000 - 666.7 - 5666.7}{1700 - 50\pi}$$

$$= \frac{38666.6}{1542.92} = 25.06 \text{ cm from Origin O. Ans.}]$$

10. From a circular plate of diameter 100 mm a circular part of diameter 50 mm is cut as shown in Fig. 5.46. Find the centroid of the remainder. (U.P. Tech. University, 2002-2003)

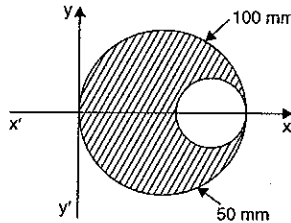

Fig. 5.46

[Hint. Fig. 5.46 is symmetrical about x-axis. Hence centroid lies on x-axis.]

$$\bar{x} = 0.6. \text{ The value of } \bar{x} \text{ is given by } \bar{x} = \frac{a_1 x_1 + a_2 x_2}{a_1 - a_2}$$

$$\text{But } a_1 = \frac{\pi}{4} \times 100^2 = 7853.98 \text{ mm}^2, x_1 = \frac{100}{2} = 50 \text{ mm}$$

$$a_2 = -\left(\frac{\pi}{4} \times 50^2\right) = -1963.5 \text{ mm}^2, x_2 = 100 - 25 = 75 \text{ mm}$$

$$\bar{x} = \frac{7853.98 \times 50 - 1963.5 \times 75}{7853.98 - 1963.5} = 41.67 \text{ mm}$$

Hence centroid is at (41.67 mm, 0). Ans.]

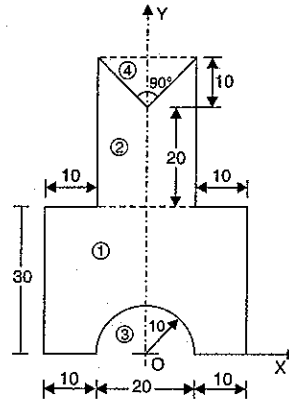

Fig. 5.45

# 6

## Shear Force and Bending Moment

### 6.1. INTRODUCTION

The algebraic sum of the vertical forces at any section of a beam to the right or left of the section is known as shear force. It is briefly written as S.F. The algebraic sum of the moments of all the forces acting to the right or left of the section is known as bending moment. It is written as B.M. In this chapter, the shear force and bending moment diagrams for different types of beams (i.e., cantilevers, simply supported, fixed, overhanging etc.) for different types of loads (i.e., point load, uniformly distributed loads, varying loads etc.) acting on the beams, will be considered.

### 6.2. SHEAR FORCE AND BENDING MOMENT DIAGRAMS

A shear force diagram is one which shows the variation of the shear force along the length of the beam. And a bending moment diagram is one which shows the variation of the bending moment along the length of the beam.

Before drawing the shear force and bending moment diagrams, we must know the different types of beams and different types of load acting on the beams.

### 6.3. TYPES OF BEAMS

The following are the important types of beams :

1. Cantilever beam,
2. Simply supported beam,
3. Overhanging beam,
4. Fixed beams, and
5. Continuous beam.

**6.3.1. Cantilever Beam.** A beam which is fixed at one end and free at the other end, is known as cantilever beam. Such beam is shown in Fig. 6.1.

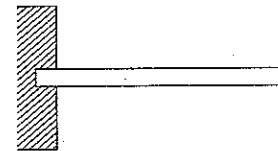

Fig. 6.1

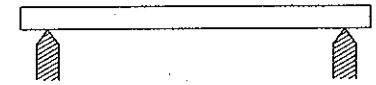

Fig. 6.2

**6.3.2. Simply Supported Beam.** A beam supported or resting freely on the supports at its both ends, is known as simply supported beam. Such beam is shown in Fig. 6.2.

**6.3.3. Overhanging Beam.** If the end portion of a beam is extended beyond the support, such beam is known as overhanging beam. Overhanging beam is shown in Fig. 6.3.

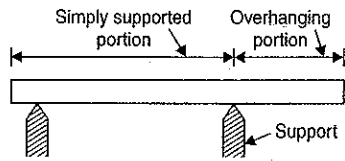

Fig. 6.3

**6.3.4. Fixed Beams.** A beam whose both ends are fixed or built-in walls, is known as fixed beam. Such beam is shown in Fig. 6.4. A fixed beam is also known as a *built-in* or *encastred* beam.

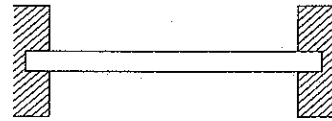

Fig. 6.4

**6.3.5. Continuous Beam.** A beam which is provided more than two supports as shown in Fig. 6.5, is known as continuous beam.



Fig. 6.5

## 6.4. TYPES OF LOAD

A beam is normally horizontal and the loads acting on the beams are generally vertical. The following are the important types of load acting on a beam :

1. Concentrated or point load,
2. Uniformly distributed load, and
3. Uniformly varying load.

**6.4.1. Concentrated or Point Load.** A concentrated load is one which is considered to act at a point, although in practice it must really be distributed over a small area. In Fig. 6.6,  $W$  shows the point load.

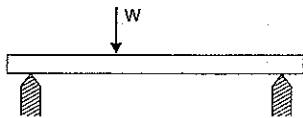

Fig. 6.6

**6.4.2. Uniformly Distributed Load.** A uniformly distributed load is one which is spread over a beam in such a manner that rate of loading  $w$  is uniform along the length (*i.e.*, each unit length is loaded to the same rate) as shown in Fig. 6.7. The rate of loading is expressed as  $w$  N/m run. Uniformly distributed load is, represented by u.d.l.

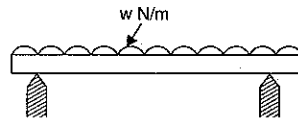

Fig. 6.7

For solving the numerical problems, the total uniformly distributed load is converted into a point load, acting at the centre of uniformly distributed load.

**6.4.3. Uniformly Varying Load.** A uniformly varying load is one which is spread over a beam in such a manner that rate of loading varies from point to point along the beam as shown in Fig. 6.8 in which load is zero at one end and increases uniformly to the other end. Such load is known as triangular load.

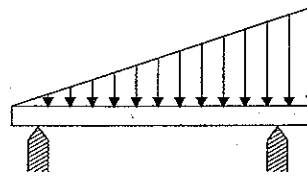

Fig. 6.8

For solving numerical problems the total load is equal to the area of the triangle and this total load is assumed to be acting at the C.G. of the triangle *i.e.*, at a distance of  $\frac{2}{3}$ rd of total length of beam from left end.

## 6.5. SIGN CONVENTIONS FOR SHEAR FORCE AND BENDING MOMENT

(i) *Shear force.* Fig. 6.9 shows a simply supported beam  $AB$ , carrying a load of 1000 N at its middle point. The reactions at the supports will be equal to 500 N. Hence  $R_A = R_B = 500$  N.

Now imagine the beam to be divided into two portions by the section  $X-X$ . The resultant of the load and reaction to the left of  $X-X$  is 500 N vertically upwards. (Note in this case, there is no load to the left of  $X-X$ ). And the resultant of the load and reaction to the right of  $X-X$  is  $(1000 \downarrow - 500 \uparrow = 500 \downarrow \text{N})$  500 N downwards. The resultant force acting on any one of the parts normal to the axis of the beam is called the *shear force* at the section  $X-X$ . Here the shear force at the section  $X-X$  is 500 N.

The shear force at a section will be considered positive when the resultant of the forces to the left to the section is upwards, or to the right of the section is downwards. Similarly the shear force at a section will be considered negative if the resultant of the forces to the left of the section is downwards, or to the right of the section is upwards. Here the resultant force to the left of the section is upwards and hence the shear force will be positive.

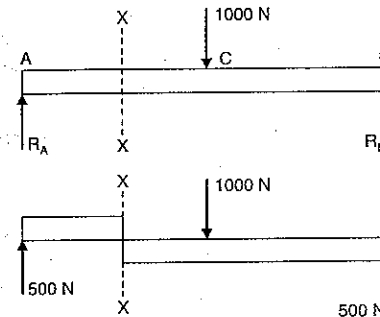

Fig. 6.9

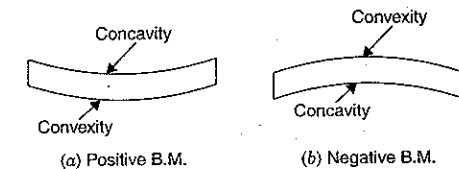

Fig. 6.10

(ii) *Bending moment.* The bending moment at a section is considered positive if the bending moment at that section is such that it tends to bend the beam to a curvature having concavity at the top as shown in Fig. 6.10 (a). Similarly the bending moment (B.M.) at a section is considered negative if the bending moment at that section is such that it tends to bend the beam to a curvature having convexity at the top as shown in Fig. 6.10 (b). The positive B.M. is often called sagging moment and negative B.M. as hogging moment.

Consider the simply supported beam  $AB$ , carrying a load of 1000 N at its middle point. Reactions  $R_A$  and  $R_B$  are equal and are having magnitude 500 N as shown in Fig. 6.11. Imagine the beam to be divided into two portions by the section  $X-X$ . Let the section  $X-X$  is at a distance of 1 m from  $A$ .

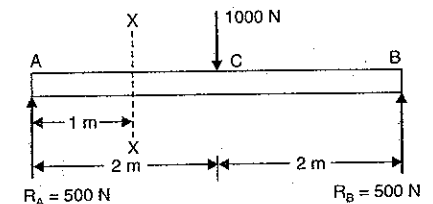

Fig. 6.11

The moments of all the forces (*i.e.*, load and reaction) to the left of  $X-X$  at the section  $X-X$  is  $R_A \times 1 = 500 \times 1 = 500$  Nm (clockwise). Also the moments of all the forces (*i.e.*, load and reaction) to the right of  $X-X$  at the section  $X-X$  is  $R_B \times 3$  (anti-clockwise)  $- 1000 \times 1$  (clockwise)  $= 500 \times 3$  Nm  $- 1000 \times 1$  Nm  $= 1500 - 1000 = 500$  Nm (anti-clockwise).

Hence the tendency of the bending moment at  $X-X$  is to bend the beam so as to produce concavity at the top as shown in Fig. 6.12.

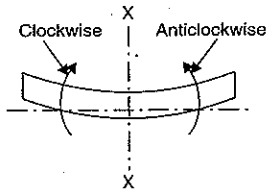

Fig. 6.12

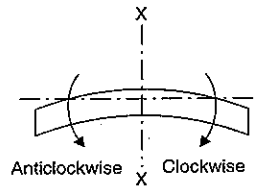

Fig. 6.13

The bending moment at a section is the algebraic sum of the moments of forces and reactions acting on one side of the section. Hence bending moment at the section  $X-X$  is 500 Nm.

The bending moment will be considered positive when the moment of the forces and reaction on the left portion is clockwise, and on the right portion anti-clockwise. In Fig. 6.12, the bending moment at the section  $X-X$  is positive.

Similarly the bending moment will be considered negative when the moment of the forces and reactions on the left portion is anti-clockwise, and on the right portion clockwise as shown in Fig. 6.13. In Fig. 6.13, the bending moment at the section  $X-X$  is negative.

#### 6.6. IMPORTANT POINTS FOR DRAWING SHEAR FORCE AND BENDING MOMENT DIAGRAMS

In Art. 6.2, it is mentioned that the shear force diagram is one which shows the variation of the shear force along the length of the beam. And a bending moment diagram is one which shows the variation of the bending moment along the length of beam. In these diagrams, the shear force or bending moment are represented by ordinates whereas the length of the beam represents abscissa.

The following are the important points for drawing shear force and bending moment diagrams :

1. Consider the left or the right portion of the section.
2. Add the forces (including reaction) normal to the beam on one of the portion. If right portion of the section is chosen, a force on the right portion acting downwards is positive while a force acting upwards is negative.
3. The positive values of shear force and bending moments are plotted above the base line, and negative values below the base line.
4. The shear force diagram will increase or decrease suddenly *i.e.*, by a vertical straight line at a section where there is a vertical point load.
5. The shear force between any two vertical loads will be constant and hence the shear force diagram between two vertical loads will be horizontal.

6. The bending moment at the two supports of a simply supported beam and at the free end of a cantilever will be zero.

#### 6.7. SHEAR FORCE AND BENDING MOMENT DIAGRAMS FOR A CANTILEVER WITH A POINT LOAD AT THE FREE END

Fig. 6.14 shows a cantilever  $AB$  of length  $L$  fixed at  $A$  and free at  $B$  and carrying a point load  $W$  at the free end  $B$ .

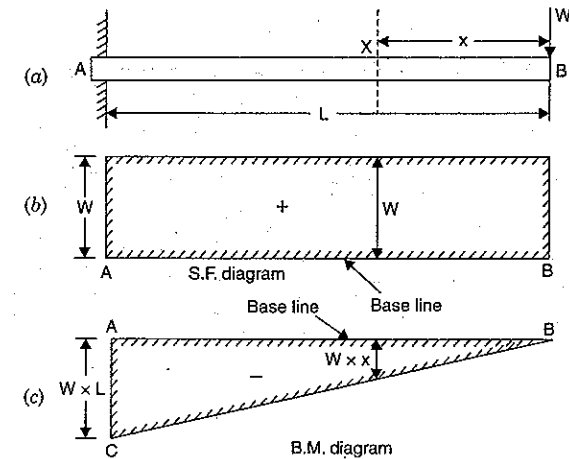

Fig. 6.14

Let  $F_x$  = Shear force at  $X$ , and  
 $M_x$  = Bending moment at  $X$ .

Take a section  $X$  at a distance  $x$  from the free end. Consider the right portion of the section.

The shear force at this section is equal to the resultant force acting on the right portion at the given section. But the resultant force acting on the right portion at the section  $X$  is  $W$  and acting in the downward direction. But a force on the right portion acting downwards is considered positive. Hence shear force at  $X$  is positive.

$$F_x = + W$$

The shear force will be constant at all sections of the cantilever between  $A$  and  $B$  as there is no other load between  $A$  and  $B$ . The shear force diagram is shown in Fig. 6.14 (b).

#### Bending Moment Diagram

The bending moment at the section  $X$  is given by

$$M_x = - W \times x \quad \dots(i)$$

(Bending moment will be negative as for the right portion of the section, the moment of  $W$  at  $X$  is clockwise. Also the bending of cantilever will take place in such a manner that convexity will be at the top of the beam).

From equation (i), it is clear that B.M. at any section is proportional to the distance of the section from the free end.

At  $x = 0$  i.e., at B, B.M. = 0

At  $x = L$  i.e., at A, B.M. =  $W \times L$

Hence B.M. follows the straight line law. The B.M. diagram is shown in Fig. 6.14 (c). At point A, take  $AC = W \times L$  in the downward direction. Join point B to C.

The shear force and bending moment diagrams for several concentrated loads acting on a cantilever, will be drawn in the similar manner.

**Problem 6.1.** A cantilever beam of length 2 m carries the point loads as shown in Fig. 6.15. Draw the shear force and B.M. diagrams for the cantilever beam.

**Sol.** Given :

Refer to Fig. 6.15.

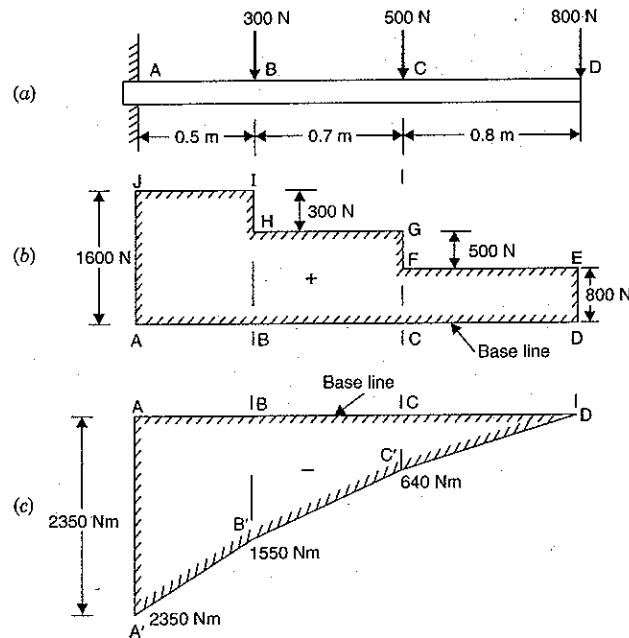

Fig. 6.15

#### Shear Force Diagram

The shear force at D is + 800 N. This shear force remains constant between D and C. At C, due to point load, the shear force becomes  $(800 + 500) = 1300$  N. Between C and B, the shear force remains 1300 N. At B again, the shear force becomes  $(1300 + 300) = 1600$  N. The shear force between B and A remains constant and equal to 1600 N. Hence the shear force at different points will be as given below :

S.F. at D,  $F_D = + 800$  N

S.F. at C,  $F_C = + 800 + 500 = + 1300$  N

S.F. at B,  $F_B = + 800 + 500 + 300 = 1600$  N

S.F. at A,  $F_A = + 1600$  N.

The shear force, diagram is shown in Fig. 6.15 (b) which is drawn as :

Draw a horizontal line AD as base line. On the base line mark the points B and C below the point loads. Take the ordinate DE = 800 N in the upward direction. Draw a line EF parallel to AD. The point F is vertically above C. Take vertical line FG = 500 N. Through G, draw a horizontal line GH in which point H is vertically above B. Draw vertical line HI = 300 N. From I, draw a horizontal line IJ. The point J is vertically above A. This completes the shear force diagram.

#### Bending Moment Diagram

The bending moment at D is zero :

(i) The bending moment at any section between C and D at a distance  $x$  and D is given by,

$$M_x = - 800 \times x \text{ which follows a straight line law.}$$

At C, the value of  $x = 0.8$  m.

$$\therefore \text{ B.M. at C, } M_C = - 800 \times 0.8 = - 640 \text{ Nm.}$$

(ii) The B.M. at any section between B and C at a distance  $x$  from D is given by (At C,  $x = 0.8$  and at B,  $x = 0.8 + 0.7 = 1.5$  m. Hence here  $x$  varies from 0.8 to 1.5).

$$M_x = - 800x - 500(x - 0.8) \quad \dots(i)$$

Bending moment between B and C also varies by a straight line law.

B.M. at B is obtained by substituting  $x = 1.5$  m in equation (i),

$$\therefore M_B = - 800 \times 1.5 - 500(1.5 - 0.8) \\ = - 1200 - 350 = - 1550 \text{ Nm.}$$

(iii) The B.M. at any section between A and B at a distance  $x$  from D is given by (At B,  $x = 1.5$  and at A,  $x = 2.0$  m. Hence here  $x$  varies from 1.5 m to 2.0 m)

$$M_x = - 800x - 500(x - 0.8) - 300(x - 1.5) \quad \dots(ii)$$

Bending moment between A and B varies by a straight line law.

B.M. at A is obtained by substituting  $x = 2.0$  m in equation (ii),

$$\therefore M_A = - 800 \times 2 - 500(2 - 0.8) - 300(2 - 1.5) \\ = - 800 \times 2 - 500 \times 1.2 - 300 \times 0.5 \\ = - 1600 - 600 - 150 = - 2350 \text{ Nm.}$$

Hence the bending moments at different points will be as given below :

$$M_D = 0$$

$$M_C = - 640 \text{ Nm}$$

$$M_B = - 1550 \text{ Nm}$$

$$M_A = - 2350 \text{ Nm.}$$

and

The bending moment diagram is shown in Fig. 6.15 (c) which is drawn as.

Draw a horizontal line AD as a base line and mark the points B and C on this line. Take vertical lines  $CC' = 640$  Nm,  $BB' = 1550$  Nm and  $AA' = 2350$  Nm in the downward direction. Join points D, C', B' and A' by straight lines. This completes the bending moment diagram.



### 6.8. SHEAR FORCE AND BENDING MOMENT DIAGRAMS FOR A CANTILEVER WITH A UNIFORMLY DISTRIBUTED LOAD

Fig. 6.16 shows a cantilever of length  $L$  fixed at  $A$  and carrying a uniformly distributed load of  $w$  per unit length over the entire length of the cantilever.

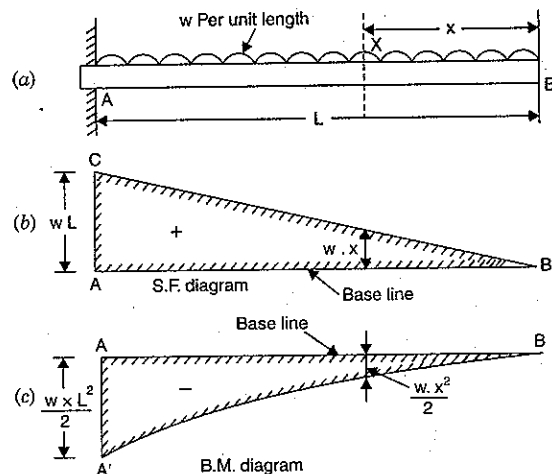

Fig. 6.16

Take a section  $X$  at a distance of  $x$  from the free end  $B$ .

Let  $F_x$  = Shear force at  $X$ , and  
 $M_x$  = Bending moment at  $X$ .

Here we have considered the right portion of the section. The shear force at the section  $X$  will be equal to the resultant force acting on the right portion of the section. But the resultant force on the right portion =  $w \times$  Length of right portion =  $w \cdot x$ .

This resultant force is acting downwards. But the resultant force on the right portion acting downwards is considered positive. Hence shear force at  $X$  is positive.

$$\therefore F_x = + w \cdot x$$

The above equation shows that the shear force follows a straight line law.

$$\text{At } B, x = 0 \text{ and hence } F_x = 0$$

$$\text{At } A, x = L \text{ and hence } F_x = w \cdot L$$

The shear force diagram is shown in Fig. 6.16 (b).

#### Bending Moment Diagram

It is mentioned in Art. 6.4.3 that the uniformly distributed load over a section is converted into point load acting at the C.G. of the section.

The bending moment at the section  $X$  is given by

$$M_x = - (\text{Total load on right portion}) \times \text{Distance of C.G. of right portion from } X$$

$$= - (w \cdot x) \cdot \frac{x}{2} = - w \cdot x \cdot \frac{x}{2} = - w \cdot \frac{x^2}{2} \quad \dots(i)$$

(The bending moment will be negative as for the right portion of the section, the moment of the load at  $x$  is clockwise. Also the bending of cantilever will take place in such a manner that convexity will be at the top of the cantilever).

From equation (i), it is clear that B.M. at any section is proportional to the square of the distance of the section from the free end. This follows a parabolic law.

$$\text{At } B, x = 0 \text{ hence } M_x = 0$$

$$\text{At } A, x = L \text{ hence } M_x = - w \cdot \frac{L^2}{2}$$

The bending moment diagram is shown in Fig. 6.16 (c).

**Problem 6.2.** A cantilever of length 2.0 m carries a uniformly distributed load of 1 kN/m run over a length of 1.5 m from the free end. Draw the shear force and bending moment diagrams for the cantilever.

**Sol. Given :**

U.D.L.,  $w = 1 \text{ kN/m run}$

Refer to Fig. 6.17.

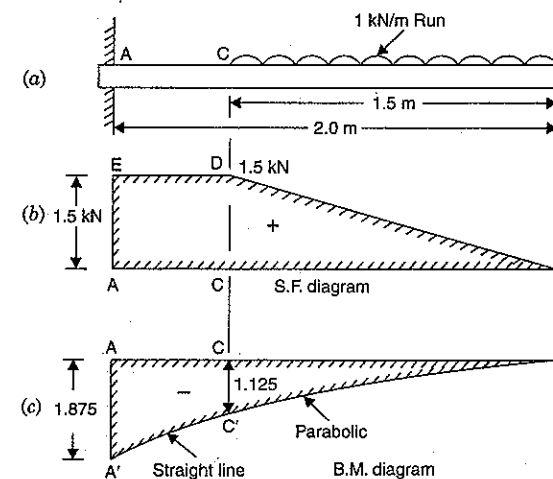

Fig. 6.17

#### Shear Force Diagram

Consider any section between  $C$  and  $B$  a distance of  $x$  from the free end  $B$ . The shear force at the section is given by

$$F_x = w \cdot x \quad (\text{+ve sign is due to downward force on right portion of the section}) \\ = 1.0 \times x \quad (\because w = 1.0 \text{ kN/m run})$$

$$\text{At } B, x = 0 \text{ hence } F_x = 0$$

$$\text{At } C, x = 1.5 \text{ hence } F_x = 1.0 \times 1.5 = 1.5 \text{ kN.}$$

The shear force follows a straight line law between  $C$  and  $B$ . As between  $A$  and  $C$  there is no load, the shear force will remain constant. Hence shear force between  $A$  and  $C$  will be represented by a horizontal line.

The shear force diagram is shown in Fig. 6.17 (b) in which

$$F_B = 0, F_C = 1.5 \text{ kN and } F_A = F_C = 1.5 \text{ kN.}$$

#### Bending Moment Diagram

(i) The bending moment at any section between C and B at a distance  $x$  from the free end B is given by

$$M_x = -(w \cdot x) \cdot \frac{x}{2} = -\left(1 \cdot \frac{x^2}{2}\right) = -\frac{x^2}{2} \quad \dots(i)$$

(The bending moment will be negative as for the right portion of the section the moment of load at  $x$  is clockwise).

$$\text{At B, } x = 0 \text{ hence } M_B = -\frac{0^2}{2} = 0$$

$$\text{At C, } x = 1.5 \text{ hence } M_C = -\frac{1.5^2}{2} = -1.125 \text{ Nm}$$

From equation (i) it is clear that the bending moment varies according to parabolic law between C and B.

(ii) The bending moment at any section between A and C at a distance  $x$  from the free end B is obtained as : (here  $x$  varies from 1.5 m to 2.0 m)

$$\text{Total load due to U.D.L.} = w \times 1.5 = 1.5 \text{ kN.}$$

This load is acting at a distance of  $\frac{1.5}{2} = 0.75$  m from the free end B or at a distance of  $(x - 0.75)$  from any section between A and C.

$$\therefore \text{Moment of this load at any section between A and C at a distance } x \text{ from free end} \\ = (\text{Load due to U.D.L.}) \times (x - 0.75)$$

$$\therefore M_x = -1.5 \times (x - 0.75) \quad \dots(ii) \\ (\text{-ve sign is due to clockwise moment for right portion})$$

From equation (ii) it is clear that the bending moment follows straight line law between A and C.

$$\text{At C, } x = 1.5 \text{ m hence } M_C = -1.5 (1.5 - 0.75) = -1.125 \text{ Nm}$$

$$\text{At A, } x = 2.0 \text{ m hence } M_A = -1.5 (2 - 0.75) = -1.875 \text{ Nm.}$$

Now the bending moment diagram is drawn as shown in Fig. 6.17 (c). In this diagram line  $CC' = 1.125$  Nm and  $AA' = 1.875$  Nm. The points B and C' are on a parabolic curve whereas the points A' and C' are joined by a straight line.

**Problem 6.3.** A cantilever of length 2.0 m carries a uniformly distributed load of 2 kN/m length over the whole length and a point load of 3 kN at the free end. Draw the S.F. and B.M. diagrams for the cantilever.

**Sol.** Given :

$$\text{Length, } L = 2.0 \text{ m}$$

$$\text{U.D.L., } w = 2 \text{ kN/m length}$$

$$\text{Point load at free end} = 3 \text{ kN}$$

Refer to Fig. 6.18.

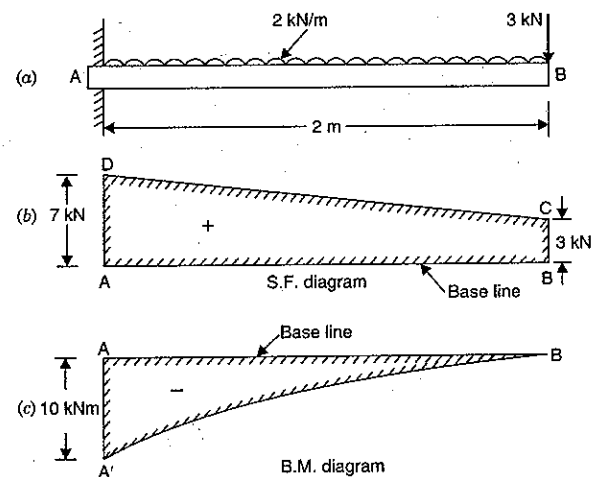

Fig. 6.18

#### Shear Force Diagram

The shear force at B = 3 kN

Consider any section at a distance  $x$  from the free end B. The shear force at the section is given by,

$$F_x = 3.0 + wx \quad (\text{+ve sign is due to downward force on right portion of the section}) \\ = 3.0 + 2 \times x \quad (\because w = 2 \text{ kN/m})$$

The above equation shows that shear force follows a straight line law.

$$\text{At B, } x = 0 \text{ hence } F_B = 3.0 \text{ kN}$$

$$\text{At A, } x = 2 \text{ m hence } F_A = 3 + 2 \times 2 = 7 \text{ kN.}$$

The shear force diagram is shown in Fig. 6.18 (b) in which  $F_B = BC = 3$  kN and  $F_A = AD = 7$  kN. The points C and D are joined by a straight line.

#### Bending Moment Diagram

The bending moment at any section at a distance  $x$  from the free end B is given by,

$$M_x = -\left(3x + wx \cdot \frac{x}{2}\right) \\ = -\left(3x + \frac{2x^2}{2}\right) \quad (\because w = 2 \text{ kN/m}) \\ = -(3x + x^2) \quad \dots(i)$$

(The bending moment will be negative as for the right portion of the section, the moment of loads at  $x$  is clockwise).

The equation (i) shows that the B.M. varies according to the parabolic law. From equation (i), we have

$$\text{At } B, x = 0 \text{ hence } M_B = -(3 \times 0 + 0^2) = 0$$

$$\text{At } A, x = 2 \text{ m hence } M_A = -(3 \times 2 + 2^2) = -10 \text{ kNm}$$

Now the bending moment diagram is drawn as shown in Fig. 6.18 (c). In this diagram,  $AA' = 10 \text{ kNm}$  and points  $A'$  and  $B$  are joined by a parabolic curve.

**Problem 6.4.** A cantilever of length 2 m carries a uniformly distributed load of 1.5 kN/m run over the whole length and a point load of 2 kN at a distance of 0.5 m from the free end. Draw the S.F. and B.M. diagrams for the cantilever.

**Sol. Given :**

Length,  $L = 2 \text{ m}$

U.D.L.,  $w = 1.5 \text{ kN/m run}$

Point load,  $W = 2 \text{ kN}$

Distance of point load from free end = 0.5 m

Refer to Fig. 6.19.

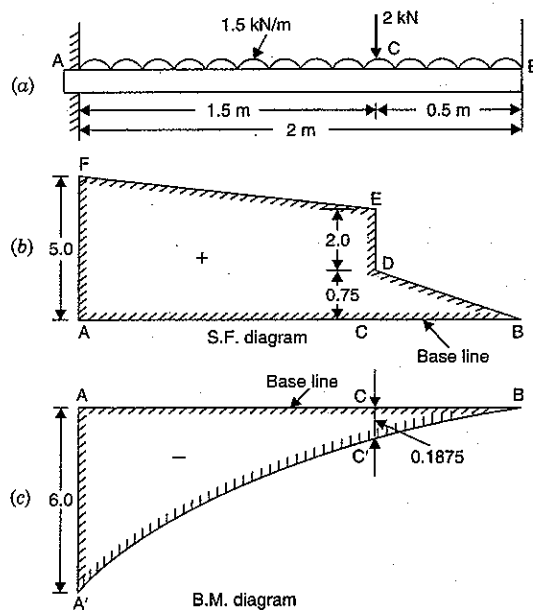

Fig. 6.19

#### Shear Force Diagram

(i) Consider any section between  $C$  and  $B$  at a distance  $x$  from the free end. The shear force at the section is given by,

$$F_x = +wx \quad \text{(+ve sign is due to downward force on right portion)}$$

$$= 1.5 \times x \quad \dots(i)$$

In equation (i),  $x$  varies from 0 to 0.5. The equation (i) shows that shear force varies by a straight line law between  $B$  and  $C$ .

$$\text{At } B, x = 0 \text{ hence } F_B = 1.5 \times 0 = 0$$

$$\text{At } C, x = 0.5 \text{ hence } F_C = 1.5 \times 0.5 = 0.75 \text{ kN}$$

(ii) Now consider any section between  $A$  and  $C$  at a distance  $x$  from free end  $B$ . The shear force at the section is given by

$$F_x = +wx + 2 \text{ kN} \quad \text{(+ve sign is due to downward force on right portion of the section)}$$

$$= 1.5x + 2 \quad \dots(ii)$$

In equation (ii),  $x$  varies from 0.5 to 2.0. The equation (ii) also shows that shear force varies by a straight line law between  $A$  and  $C$ .

$$\text{At } C, x = 0.5 \text{ hence } F_C = 1.5 \times 0.5 + 2 = 2.75 \text{ kN}$$

$$\text{At } A, x = 2.0 \text{ hence } F_A = 1.5 \times 2.0 + 2 = 5.0 \text{ kN}$$

Now draw the shear force diagram as shown in Fig. 6.19 (b) in which  $CD = 0.75 \text{ kN}$ ,  $DE = 2.0 \text{ kN}$  or  $CE = 2.75 \text{ kN}$  and  $AF = 5.0 \text{ kN}$ . The point  $B$  is joined to point  $D$  by a straight line whereas the point  $E$  is also joined to point  $F$  by a straight line.

#### Bending Moment Diagram

(i) The bending moment at any section between  $C$  and  $B$  at a distance  $x$  from the free end  $B$  is given by

$$M_x = -(wx) \cdot \frac{x}{2}$$

$$= -(1.5 \times x) \cdot \frac{x}{2} \quad (\because w = 1.5 \text{ kN/m})$$

$$= -0.75x^2 \quad \dots(iii)$$

(The bending moment will be negative as for the right portion of the section the moment at the section is clockwise).

In equation (iii),  $x$  varies from 0 to 0.5. Equation (iii) shows that B.M. varies between  $C$  and  $B$  by a parabolic law.

$$\text{At } B, x = 0 \text{ hence } M_B = -0.75 \times 0 = 0$$

$$\text{At } C, x = 0.5 \text{ hence } M_C = -0.75 \times 0.5^2 = -0.1875 \text{ kNm}$$

(ii) The bending moment at any section between  $A$  and  $C$  at a distance  $x$  from the free end  $B$  is given by

$$M_x = -(wx) \cdot \frac{x}{2} - 2(x - 0.5) = -(1.5 \times x) \cdot \frac{x}{2} - 2(x - 0.5)$$

$$= -0.75x^2 - 2(x - 0.5) \quad \dots(iv)$$

In equation (iv),  $x$  varies from 0.5 to 2.0. Equation (iv) shows that B.M. varies by a parabolic law between  $A$  and  $C$ .

$$\text{At } C, x = 0.5 \text{ hence } M_C = -0.75 \times 0.5^2 - 2(0.5 - 0.5) = -0.1875 \text{ kNm}$$

$$\text{At } A, x = 2.0 \text{ hence } M_A = -0.75 \times 2^2 - 2(2.0 - 0.5) = -3.0 - 3.0 = -6.0 \text{ kNm}$$

Now the bending moment diagram is drawn as shown in Fig. 6.19 (c). In this diagram line  $CC' = 0.1875$  and  $AA' = 6.0$ . The points  $A'$ ,  $C'$  and  $B$  are on parabolic curves.

**Problem 6.5.** A cantilever 1.5 m long is loaded with a uniformly distributed load of 2 kN/m run over a length of 1.25 m from the free end. It also carries a point load of 3 kN at a distance of 0.25 m from the free end. Draw the shear force and bending moment diagrams of the cantilever.

**Sol. Given :**

Length,  $L = 1.5$  m  
 U.D.L.,  $w = 2$  kN/m  
 Point load,  $W = 3$  kN  
 Refer to Fig. 6.20.

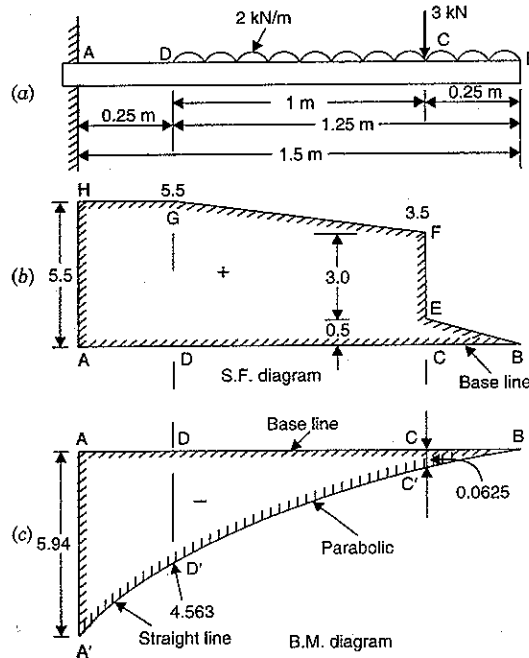

Fig. 6.20

#### Shear Force Diagram

The shear force at B is zero.

The shear force increases to  $2 \times 0.25 = 0.5$  kN by a straight line at C. Due to point load of 3 kN, the shear force suddenly increases to  $0.5 + 3 = 3.5$  kN at C.

The shear force further increases to  $3.5 + 2 \times 1 = 5.5$  kN by a straight line at D. The shear force remains constant between A and D as there is no load between A and D.

Now the shear force diagram is drawn as shown in Fig. 6.20 (b). In this diagram line CE = 0.5 kN, CF = 3.5 kN, DG = 5.5 kN and AH = 5.5 kN. The point B is joined to E by a straight line. The point F is also joined to G by a straight line. Line GH is horizontal.

#### Bending Moment Diagram

B.M. at B = 0

$$\text{B.M. at D} = -2 \times 0.25 \times \frac{0.25}{2} = -0.0625 \text{ kNm}$$

$$\text{B.M. at D} = -2 \times 1.25 \times \frac{1.25}{2} - (3 \times 1) = -4.563 \text{ kNm}$$

$$\text{B.M. at A} = -2 \times 1.25 \times \left( \frac{1.25}{2} + 0.25 \right) - 3 \times (1 + 0.25) = -5.94 \text{ kNm.}$$

The bending moment between B and C and between C and D varies by a parabolic law. But B.M. between A and D varies by a straight line law.

Now the bending moment diagram is drawn as shown in Fig. 6.20 (c). In this diagram line CC' = 0.0625, DD' = 4.563 and AA' = 5.94. The points B, C' and D' are on parabolic curve whereas points A' and D' are joined by a straight line.

**Problem 6.6.** A cantilever of length 5.0 m is loaded as shown in Fig. 6.21. Draw the S.F. and B.M. diagrams for the cantilever.

**Sol.** The shear force at B is 2.5 kN and remains constant between B and C.

The shear force increases by a straight line law to  $2.5 + 2 \times 1 = 4.5$  kN at D. The shear force remains constant between D and E. At point E, the shear force suddenly increases to  $4.5 + 3 = 7.5$  kN due to point load at E. Again the shear force remains constant between A and E. Now the shear force diagram is drawn as shown in Fig. 6.21 (b).

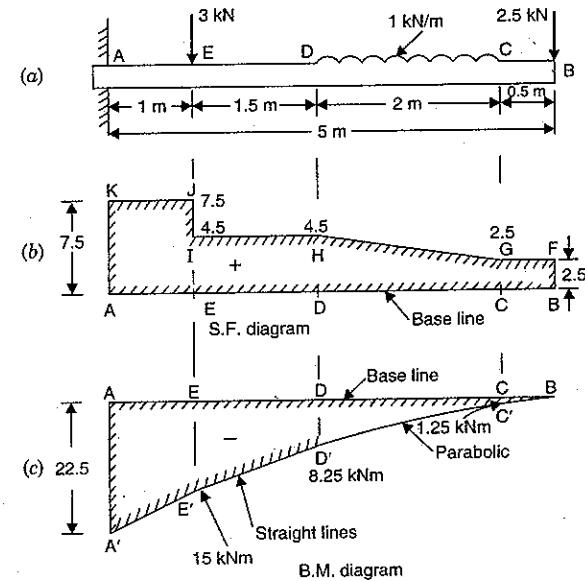

Fig. 6.21

**Bending Moment Diagram**

B.M. at B = 0

B.M. at C =  $-2.5 \times 0.5 = -1.25$  kNmB.M. at D =  $-2.5 \times 2.5 - 2 \times 1 \times 1 = -8.25$  kNmB.M. at E =  $-2.5 \times 4 - 2 \times 1 \times (1.5 + 1.0) = -10 - 5 = -15$  kNmB.M. at A =  $-2.5 \times 5 - 2 \times 1 \times (1 + 1.5 + 1.0) - 3 \times 1$   
=  $-12.5 - 7.0 - 3 = -22.5$  kNm.

Now the bending moment diagram is drawn as shown in Fig. 6.21 (c). In this diagram, the B.M. varies according to parabolic law between points C and D only. Between other points B.M. varies according to straight line law.

**6.9. SHEAR FORCE AND BENDING MOMENT DIAGRAMS FOR A CANTILEVER CARRYING A GRADUALLY VARYING LOAD**

Fig. 6.22 shows a cantilever of length  $L$  fixed at A and carrying a gradually varying load from zero at the free end to  $w$  per unit length at the fixed end.

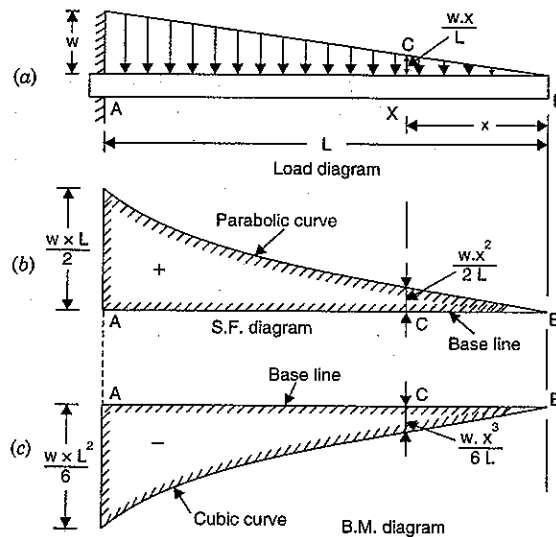

Fig. 6.22

Take a section  $X$  at a distance  $x$  from the free end  $B$ .

Let  $F_x$  = Shear force at the section  $X$ , and  
 $M_x$  = Bending moment at the section  $X$ .

Let us first find the rate of loading at the section  $X$ . The rate of loading is zero at  $B$  and is  $w$  per metre run at  $A$ . This means that rate of loading for a length  $L$  is  $w$  per unit length.

Hence rate of loading for a length of  $x$  will be  $\frac{w}{L} \times x$  per unit length. This is shown in Fig. 6.22 (a)

by  $CX$ , which is also known as load diagram. Hence  $CX = \frac{w \cdot x}{L}$ .

The shear force and the section  $X$  at a distance  $x$  from free end is given by,

$$F_x = \text{Total load on the cantilever for a length } x \text{ from the free end } B \\ = \text{Area of triangle } BCX \\ = \frac{XB \cdot XC}{2} = \frac{x \left( \frac{w \cdot x}{L} \right)}{2} \quad \left( \because XB = x, XC = \frac{w \cdot x}{L} \right) \\ = \frac{w \cdot x^2}{2L} \quad \dots(i)$$

The equation (i) shows that the S.F. varies according to the parabolic law.

$$\text{At } B, x = 0 \text{ hence } F_B = \frac{w \times 0^2}{2L} = 0$$

$$\text{At } A, x = L \text{ hence } F_A = \frac{w \cdot L^2}{2L} = \frac{w \cdot L}{2}$$

The bending moment at the section  $X$  at a distance  $x$  from the free end  $B$  is given by,

$$M_x = -(\text{Total load for a length } x) \times \text{Distance of the load from } X \\ = -(\text{Area of triangle } BCX) \times \text{Distance of C.G. of the triangle from } X \\ = -\left( \frac{wx^2}{2L} \right) \times \frac{x}{3} = -\frac{wx^3}{6L} \quad \dots(ii)$$

The equation (ii) shows that the B.M. varies according to the cubic law.

$$\text{At } B, x = 0 \text{ hence } M_B = -\frac{w \times 0}{6L} = 0$$

$$\text{At } A, x = L \text{ hence } M_A = -\frac{w \cdot L^3}{6L} = -\frac{w \cdot L^2}{6}$$

**Problem 6.7.** A cantilever of length 4 m carries a gradually varying load, zero at the free end to 2 kN/m at the fixed end. Draw the S.F. and B.M. diagrams for the cantilever.

**Sol.** Given :

Length,  $L = 4$  m

Load at fixed end,  $w = 2$  kN/m

**Shear Force Diagram**

The shear force is zero at  $B$ . The shear force at  $C$  will be equal to the area of load diagram  $ABC$ .

$$\therefore \text{Shear force at } C = \frac{4 \times 2}{2} = 4 \text{ kN}$$

The shear force between  $A$  and  $B$  varies according to parabolic law.

**Bending Moment Diagram**

The B.M. at  $B$  is zero. The bending moment at  $A$  is equal to  $-\frac{w \cdot L^2}{6}$ .

$$\therefore M_A = -\frac{w \cdot L^2}{6} = -\frac{2 \times 4^2}{6} = -5.33 \text{ kNm.}$$

The B.M. between  $A$  and  $B$  varies according to cubic law.

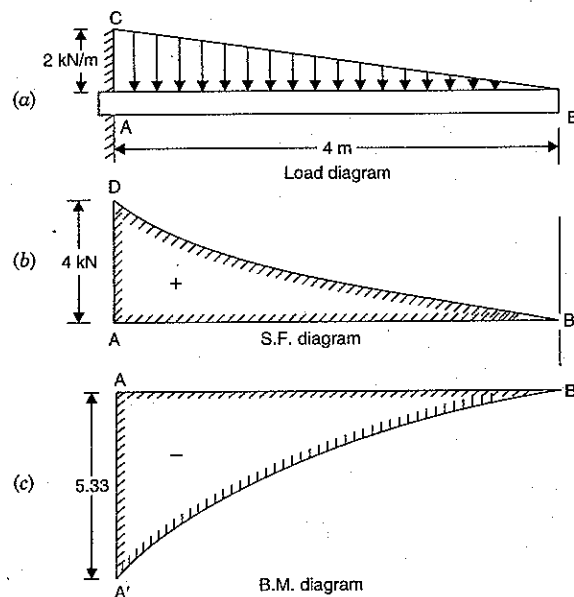

Fig. 6.23

**6.10. SHEAR FORCE AND BENDING MOMENT DIAGRAMS FOR A SIMPLY SUPPORTED BEAM WITH A POINT LOAD AT MID-POINT**

Fig. 6.24 shows a beam *AB* of length *L* simply supported at the ends *A* and *B* and carrying a point load *W* at its middle point *C*.

The reactions at the support will be equal to  $\frac{W}{2}$  as the load is acting at the middle point of the beam. Hence  $R_A = R_B = \frac{W}{2}$ .

Take a section *X* at a distance *x* from the end *A* between *A* and *C*.

Let  $F_x$  = Shear force at *X*,  
and  $M_x$  = Bending moment at *X*.

Here we have considered the *left portion* of the section. The shear force at *X* will be equal to the resultant force acting on the left portion of the section. But the resultant force on the left portion is  $\frac{W}{2}$  acting upwards. But according to the sign convention, the resultant force on the *left portion* acting upwards is considered positive. Hence shear force at *X* is positive and its magnitude is  $\frac{W}{2}$ .

$$F_x = + \frac{W}{2}$$

Hence the shear force between *A* and *C* is constant and equal to  $+\frac{W}{2}$ .

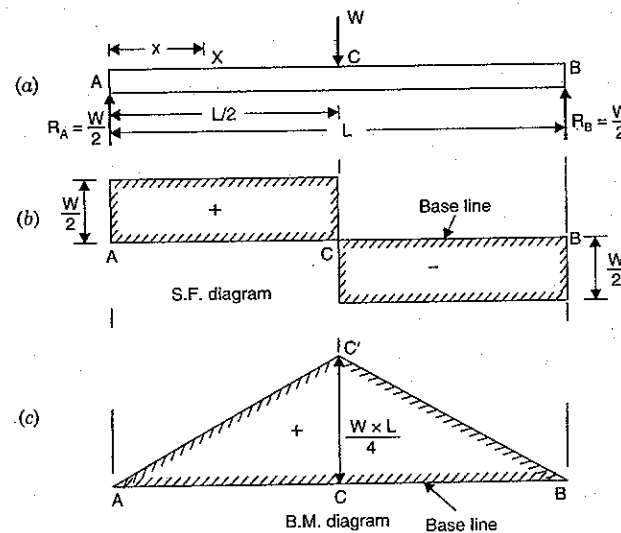

Fig. 6.24

Now consider any section between *C* and *B* at distance *x* from end *A*. The resultant force on the left portion will be

$$\left(\frac{W}{2} - W\right) = -\frac{W}{2}$$

This force will also remain constant between *C* and *B*. Hence shear force between *C* and *B* is equal to  $-\frac{W}{2}$ .

At the section *C* the shear force changes from  $+\frac{W}{2}$  to  $-\frac{W}{2}$ .

The shear force diagram is shown in Fig. 6.24 (b).

**Bending Moment Diagram**

(i) The bending moment at any section between *A* and *C* at a distance of *x* from the end *A*, is given by

$$M_x = R_A \cdot x \quad \text{or} \quad M_x = + \frac{W}{2} \cdot x \quad \dots(i)$$

(B.M. will be positive as for the *left portion* of the section, the moment of all forces at *X* is clockwise. Moreover, the bending of beam takes place in such a manner that concavity is at the top of the beam).

At *A*,  $x = 0$  hence  $M_A = \frac{W}{2} \times 0 = 0$

At *C*,  $x = \frac{L}{2}$  hence  $M_C = \frac{W}{2} \times \frac{L}{2} = \frac{W \times L}{4}$

From equation (i), it is clear that B.M. varies according to straight line law between A and C. B.M. is zero at A and it increases to  $\frac{W \times L}{4}$  at C.

(ii) The bending moment at any section between C and B at a distance  $x$  from the end A, is given by

$$M_x = R_A \cdot x - W \times \left(x - \frac{L}{2}\right) = \frac{W}{2} \cdot x - Wx + W \times \frac{L}{2} = \frac{WL}{2} - \frac{2x}{2}$$

$$\text{At } C, x = \frac{L}{2} \text{ hence } M_C = \frac{WL}{2} - \frac{W}{2} \times \frac{L}{2} = \frac{W \times L}{4}$$

$$\text{At } B, x = L \text{ hence } M_B = \frac{WL}{2} - \frac{W}{2} \times L = 0.$$

Hence bending moment at C is  $\frac{WL}{4}$  and it decreases to zero at B. Now the B.M. diagram can be completed as shown in Fig. 6.24 (c).

**Note.** The bending moment is maximum at the middle point C, where the shear force changes its sign.

### 6.11. SHEAR FORCE AND BENDING MOMENT DIAGRAMS FOR A SIMPLY SUPPORTED BEAM WITH AN ECCENTRIC POINT LOAD

Fig. 6.25 shows a beam AB of length  $L$ , simply supported at the ends A and B and carrying a point load  $W$  at C at a distance of ' $a$ ' from the end A.

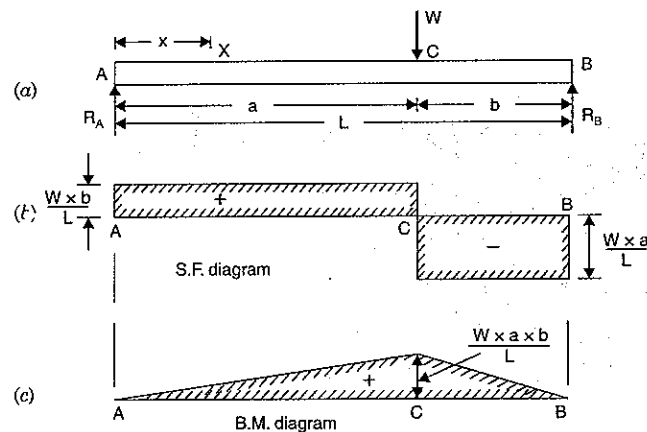

Fig. 6.25

Let  $R_A$  = Reaction at the support A, and  
 $R_B$  = Reaction at the support B.

First calculate the reactions, by taking moments about A or about B.

Taking moments of the forces on the beam about A, we get

$$R_B \times L = W \times a$$

$$\therefore R_B = \frac{W \cdot a}{L}$$

$$\begin{aligned} \text{and } R_A &= W - R_B = W - \frac{W \cdot a}{L} \\ &= W \left(1 - \frac{a}{L}\right) = W \left(\frac{L-a}{L}\right) = \frac{W \times b}{L} \quad (\because L-a=b) \end{aligned}$$

Consider a section X at a distance  $x$  from the end A between A and C.

The shear force  $F_x$  at the section is given by,

$$F_x = +R_A = +\frac{W \cdot b}{L} \quad \dots(i)$$

(The shear force will be positive as the resultant force on the left portion of the section is acting upwards).

The shear force between A and C is constant and equal to  $\frac{W \cdot b}{L}$ .

Now consider any section between C and B at a distance  $x$  from the end A. The resultant force on the left portion will be  $R_A - W$

$$\text{or } \frac{W \cdot b}{L} - W = W \cdot \left(\frac{b-L}{L}\right) = -W \left(\frac{L-b}{L}\right) = -\frac{W \cdot a}{L} \quad (\because L-b=a)$$

The shear force between C and B is constant and equal to  $-\frac{W \cdot a}{L}$ . At the section C, the shear force changes from  $\frac{W \cdot b}{L}$  to  $-\frac{W \cdot a}{L}$ . The shear force diagram is shown in Fig. 6.25 (b).

**Bending Moment Diagram**

(i) The bending moment at any section between A and C at a distance  $x$  from the end A, is given by

$$M_x = R_A \times x = +\frac{W \cdot b}{L} \cdot x \quad (\text{Plus sign due to sagging})$$

$$\text{At } A, x = 0 \text{ hence } M_A = \frac{W \cdot b}{L} \times 0 = 0$$

$$\text{At } C, x = a \text{ hence } M_C = \frac{W \cdot b}{L} \cdot a = \frac{W \cdot a \cdot b}{L}$$

Hence the B.M. increases from zero at A to  $\frac{W \cdot a \cdot b}{L}$  at C by a straight line law. The B.M. is zero at B. Hence B.M. will decrease from  $\frac{W \cdot a \cdot b}{L}$  at C to zero at B following a straight line law. The B.M. diagram is drawn in Fig. 6.25 (c).

From the shear force and bending moment diagrams, it is clear that the B.M. is maximum at C where the S.F. changes its sign.

**Problem 6.8.** A simply supported beam of length 6 m, carries point load of 3 kN and 6 kN at distances of 2 m and 4 m from the left end. Draw the shear force and bending moment diagrams for the beam.

**Sol.** First calculate the reactions  $R_A$  and  $R_B$ .

Taking moments of the force about A, we get

$$R_B \times 6 = 3 \times 2 + 6 \times 4 = 30$$

$$\therefore R_B = \frac{30}{6} = 5 \text{ kN}$$

$$\therefore R_A = \text{Total load on beam} - R_B = (3 + 6) - 5 = 4 \text{ kN}$$

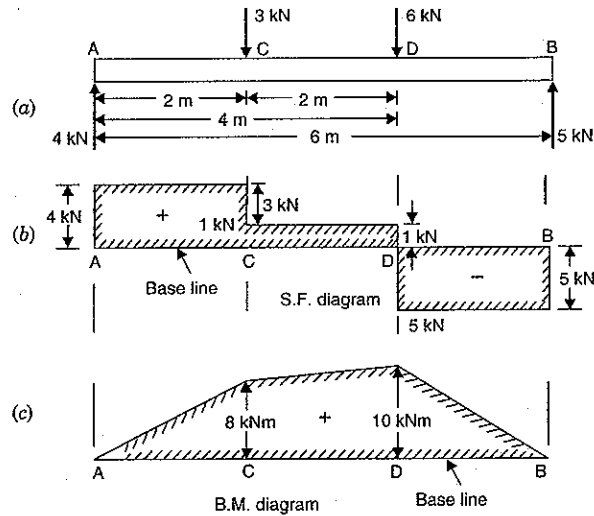

Fig. 6.26

**Shear Force Diagram**

Shear force at A,  $F_A = +R_A = +4 \text{ kN}$

Shear force between A and C is constant and equal to  $+4 \text{ kN}$

Shear force at C,  $F_C = +4 - 3.0 = +1 \text{ kN}$

Shear force between C and D is constant and equal to  $+1 \text{ kN}$ .

Shear force at D,  $F_D = +1 - 6 = -5 \text{ kN}$

The shear force between D and B is constant and equal to  $-5 \text{ kN}$ .

Shear force at B,  $F_B = -5 \text{ kN}$

The shear force diagram is drawn as shown in Fig. 6.26 (b).

**Bending Moment Diagram**

B.M. at A,  $M_A = 0$

B.M. at C,  $M_C = R_A \times 2 = 4 \times 2 = +8 \text{ kNm}$

B.M. at D,  $M_D = R_A \times 4 - 3 \times 2 = 4 \times 4 - 3 \times 2 = +10 \text{ kNm}$

B.M. at B,  $M_B = 0$

The bending moment diagram is drawn as shown in Fig. 6.26 (c).

**6.12. SHEAR FORCE AND BENDING MOMENT DIAGRAMS FOR A SIMPLY SUPPORTED BEAM CARRYING A UNIFORMLY DISTRIBUTED LOAD**

Fig. 6.27 shows a beam  $AB$  of length  $L$  simply supported at the ends  $A$  and  $B$  and carrying a uniformly distributed load of  $w$  per unit length over the entire length. The reactions at the supports will be equal and their magnitude will be half the total load on the entire length.

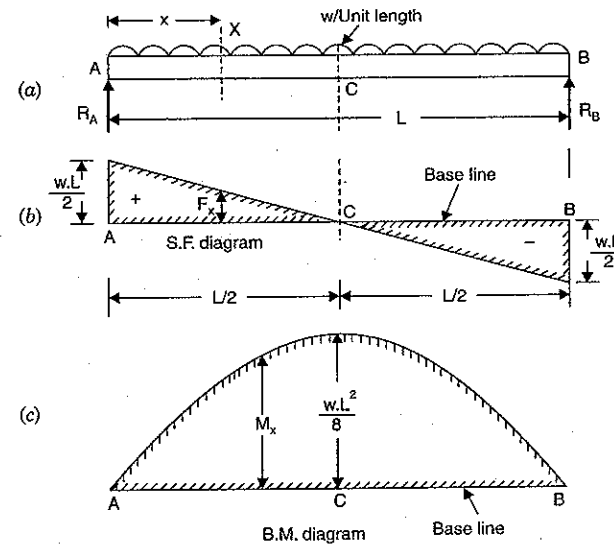

Fig. 6.27

Let  $R_A =$  Reaction at A, and

$R_B =$  Reaction at B

$$\therefore R_A = R_B = \frac{w.L}{2}$$

Consider any section  $X$  at a distance  $x$  from the left end  $A$ . The shear force at the section (i.e.,  $F_x$ ) is given by,

$$F_x = +R_A - w \cdot x = +\frac{w.L}{2} - w \cdot x \quad \dots(i)$$

From equation (i), it is clear that the shear force varies according to straight line law.

The values of shear force at different points are :

$$\text{At A, } x = 0 \text{ hence } F_A = +\frac{w.L}{2} - \frac{w \cdot 0}{2} = +\frac{w.L}{2}$$

$$\text{At B, } x = L \text{ hence } F_B = +\frac{w.L}{2} - w.L = -\frac{w.L}{2}$$

$$\text{At C, } x = \frac{L}{2} \text{ hence } F_C = +\frac{w.L}{2} - w \cdot \frac{L}{2} = 0$$

The shear force diagram is drawn as shown in Fig. 6.27 (b).

The bending moment at the section  $X$  at a distance  $x$  from left end  $A$  is given by,

$$\begin{aligned} M_x &= +R_A \cdot x - w \cdot x \cdot \frac{x}{2} \\ &= \frac{w.L}{2} \cdot x - \frac{w \cdot x^2}{2} \quad \left( \because R_A = \frac{w.L}{2} \right) \dots(ii) \end{aligned}$$

From equation (ii), it is clear that B.M. varies according to parabolic law.



The values of B.M. at different points are :

$$\text{At } A, x = 0 \text{ hence } M_A = \frac{w \cdot L}{2} \cdot 0 - \frac{w \cdot 0}{2} = 0$$

$$\text{At } B, x = L \text{ hence } M_B = \frac{w \cdot L}{2} \cdot L - \frac{w}{2} \cdot L^2 = 0$$

$$\text{At } C, x = \frac{L}{2} \text{ hence } M_C = \frac{w \cdot L}{2} \cdot \frac{L}{2} - \frac{w}{2} \cdot \left(\frac{L}{2}\right)^2 = \frac{w \cdot L^2}{4} - \frac{w \cdot L^2}{8} = + \frac{w \cdot L^2}{8}$$

Thus the B.M. increases according to parabolic law from zero at A to  $+\frac{w \cdot L^2}{8}$  at the middle point of the beam and from this value the B.M. decreases to zero at B according to the parabolic law.

Now the B.M. diagram is drawn as shown in Fig. 6.27 (c).

**Problem 6.9.** Draw the shear force and bending moment diagram for a simply supported beam of length 9 m and carrying a uniformly distributed load of 10 kN/m for a distance of 6 m from the left end. Also calculate the maximum B.M. on the section.

**Sol.** First calculate reactions  $R_A$  and  $R_B$ .

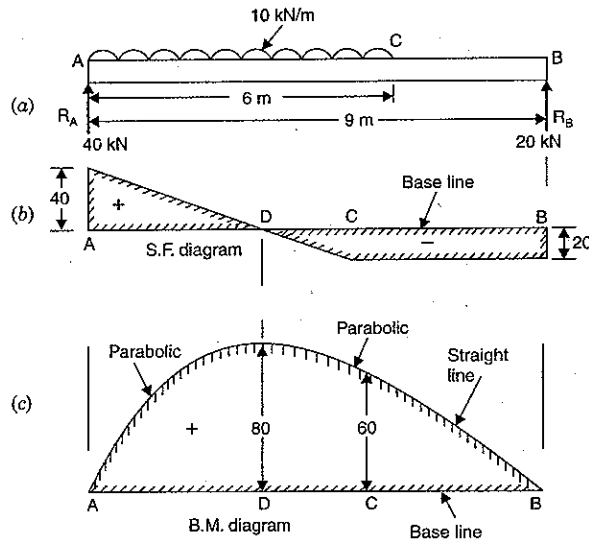

Fig. 6.28

Taking moments of the forces about A, we get

$$R_B \times 9 = 10 \times 6 \times \frac{6}{2} = 180$$

$$\therefore R_B = \frac{180}{9} = 20 \text{ kN}$$

$$\therefore R_A = \text{Total load on beam} - R_B = 10 \times 6 - 20 = 40 \text{ kN.}$$

### Shear Force Diagram

Consider any section at a distance  $x$  from A between A and C. The shear force at the section is given by,

$$F_x = +R_A - 10x = +40 - 10x \quad \dots(i)$$

Equation (i) shows that shear force varies by a straight line law between A and C.

$$\text{At } A, x = 0 \text{ hence } F_A = +40 - 0 = 40 \text{ kN}$$

$$\text{At } C, x = 6 \text{ m hence } F_C = +40 - 10 \times 6 = -20 \text{ kN}$$

The shear force at A is +40 kN and at C is -20 kN. Also shear force between A and C varies by a straight line. This means that somewhere between A and C, the shear force is zero. Let the S.F. is zero at  $x$  metre from A. Then substituting the value of S.F. (i.e.,  $F_x$ ) equal to zero in equation (i), we get

$$0 = 40 - 10x$$

$$\therefore x = \frac{40}{10} = 4 \text{ m}$$

Hence shear force is zero at a distance 4 m from A.

The shear force is constant between C and B. This equal to -20 kN.

Now the shear force diagram is drawn as shown in Fig. 6.28 (b). In the shear force diagram, distance AD = 4 m. The point D is at a distance 4 m from A.

### B.M. Diagram

The B.M. at any section between A and C at a distance  $x$  from A is given by,

$$M_x = R_A \times x - 10 \cdot x \cdot \frac{x}{2} = 40x - 5x^2 \quad \dots(ii)$$

Equation (ii) shows that B.M. varies according to parabolic law between A and C.

$$\text{At } A, x = 0 \text{ hence } M_A = 40 \times 0 - 5 \times 0 = 0$$

$$\text{At } C, x = 6 \text{ m hence } M_C = 40 \times 6 - 5 \times 6^2 = 240 - 180 = +60 \text{ kNm}$$

$$\text{At } D, x = 4 \text{ m hence } M_D = 40 \times 4 - 5 \times 4^2 = 160 - 80 = +80 \text{ kNm}$$

The bending moment between C and B varies according to linear law.

B.M. at B is zero whereas at C is 60 kNm.

The bending moment diagram is drawn as shown in Fig. 6.28 (c).

### Maximum Bending Moment

The B.M. is maximum at a point where shear force changes sign. This means that the point where shear force becomes zero from positive value to the negative or *vice-versa*, the B.M. at that point will be maximum. From the shear force diagram, we know that at point D, the shear force is zero after changing its sign. Hence B.M. is maximum at point D. But the B.M. at D is +80 kNm.

$$\therefore \text{Max. B.M.} = +80 \text{ kN. Ans.}$$

**Problem 6.10.** Draw the shear force and B.M. diagrams for a simply supported beam of length 8 m and carrying a uniformly distributed load of 10 kN/m for a distance of 4 m as shown in Fig. 6.29.

**Sol.** First calculate the reactions  $R_A$  and  $R_B$ .

Taking moments of the forces about A, we get

$$R_B \times 8 = 10 \times 4 \times \left(1 + \frac{4}{2}\right) = 120$$

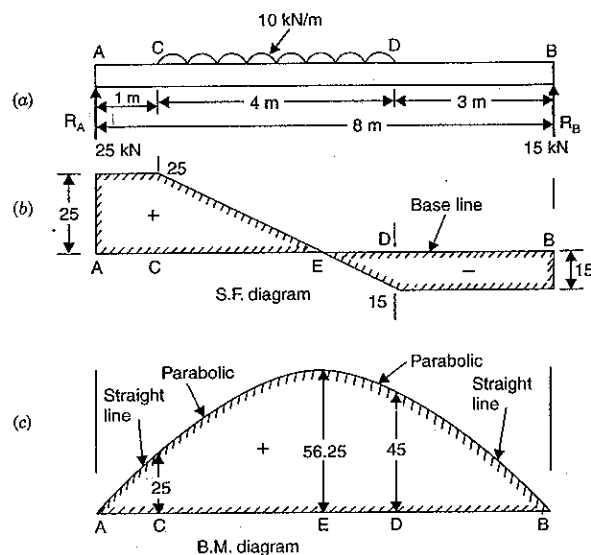

Fig. 6.29

$$\therefore R_B = \frac{120}{8} = 15 \text{ kN}$$

$$\therefore R_A = \text{Total load on beam} - R_B \\ = 10 \times 4 - 15 = 25 \text{ kN}$$

#### Shear Force Diagram

The shear force at A is +25 kN. The shear force remains constant between A and C and equal to +25 kN. The shear force at B is -15 kN. The shear force remains constant between B and D and equal to -15 kN. The shear force at any section between C and D at a distance  $x$  from A is given by,

$$F_x = +25 - 10(x - 1) \quad \dots(i)$$

$$\text{At } C, x = 1 \text{ hence } F_C = +25 - 10(1 - 1) = +25 \text{ kN}$$

$$\text{At } D, x = 5 \text{ hence } F_D = +25 - 10(5 - 1) = -15 \text{ kN}$$

The shear force at C is +25 kN and at D is -15 kN. Also shear force between C and D varies by a straight line law. This means that somewhere between C and D, the shear force is zero. Let the S.F. be zero at  $x$  metre from A. Then substituting the value of S.F. (i.e.,  $F_x$ ) equal to zero in equation (i), we get

$$0 = 25 - 10(x - 1)$$

$$0 = 25 - 10x + 10 \quad \text{or} \quad 10x = 35$$

or

$$\therefore x = \frac{35}{10} = 3.5 \text{ m}$$

Hence the shear force is zero at a distance 3.5 m from A.

Hence the distance  $AE = 3.5$  m in the shear force diagram shown in Fig. 6.29 (b).

#### B.M. Diagram

B.M. at A is zero

B.M. at B is also zero

B.M. at C =  $R_A \times 1 = 25 \times 1 = 25 \text{ kNm}$

The B.M. at any section between C and D at a distance  $x$  from A is given by,

$$M_x = R_A \cdot x - 10(x - 1) \cdot \frac{(x - 1)}{2} = 25 \times x - 5(x - 1)^2 \quad \dots(ii)$$

At C,  $x = 1$  hence  $M_C = 25 \times 1 - 5(1 - 1)^2 = 25 \text{ kNm}$

At D,  $x = 5$  hence  $M_D = 25 \times 5 - 5(5 - 1)^2 = 125 - 80 = 45 \text{ kNm}$

At E,  $x = 3.5$  hence  $M_E = 25 \times 3.5 - 5(3.5 - 1)^2 = 87.5 - 31.25 = 56.25 \text{ kNm}$

B.M. will increase from 0 at A to 25 kNm at C by a straight line law. Between C and D the B.M. varies according to parabolic law as is clear from equation (ii). Between C and D, the B.M. will be maximum at E. From D to B the B.M. will decrease from 45 kNm at D to zero at B according to straight line law.

**Problem 6.11.** Draw the S.F. and B.M. diagrams of a simply supported beam of length 7 m carrying uniformly distributed loads as shown in Fig. 6.30.

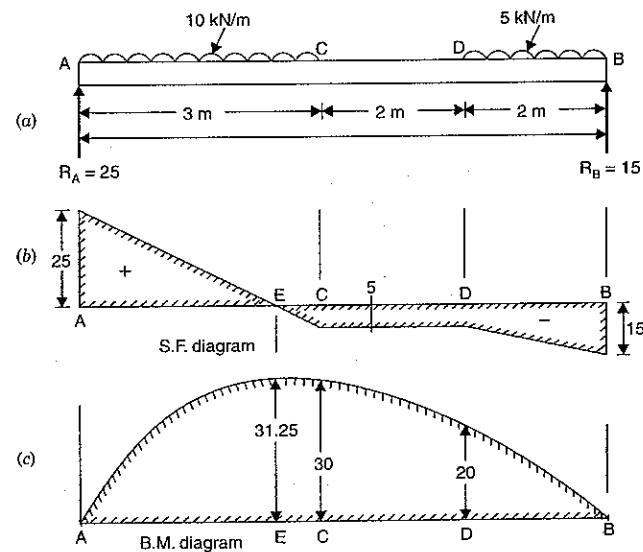

Fig. 6.30

**Sol.** First calculate the reactions  $R_A$  and  $R_B$ .

Taking moments of all forces about A, we get

$$R_B \times 7 = 10 \times 3 \times \frac{3}{2} + 5 \times 2 \times \left(3 + 2 + \frac{2}{2}\right) = 45 + 60 = 105$$

$\therefore$

$$R_B = \frac{105}{7} = 15 \text{ kN}$$

and

$$R_A = \text{Total load on beam} - R_B \\ = (10 \times 3 + 5 \times 2) - 15 = 40 - 15 = 25 \text{ kN}$$

**S.F. Diagram**

The shear force at A is + 25 kN

The shear force at C =  $R_A - 3 \times 10 = +25 - 30 = -5$  kN

The shear force varies between A and C by a straight line law.

The shear force between C and D is constant and equal to - 5 kN

The shear force at B is - 15 kN

The shear force between D and B varies by a straight line law.

The shear force diagram is drawn as shown in Fig. 6.30 (b).

The shear force is zero at point E between A and C. Let us find the location of E from A.

Let the point E be at a distance x from A.

The shear force at E =  $R_A - 10 \times x = 25 - 10x$ 

But shear force at E = 0

$$\therefore 25 - 10x = 0 \quad \text{or} \quad 10x = 25$$

$$\text{or} \quad x = \frac{25}{10} = 2.5 \text{ m}$$

**B.M. Diagram**

B.M. at A is zero

B.M. at B is zero

$$\text{B.M. at C,} \quad M_C = R_A \times 3 - 10 \times 3 \times \frac{3}{2} = 25 \times 3 - 45 = 75 - 45 = 30 \text{ kNm}$$

At E,  $x = 2.5$  and hence

$$\text{B.M. at E,} \quad M_E = R_A \times 2.5 - 10 \times 2.5 \times \frac{2.5}{2} = 25 \times 2.5 - 5 \times 6.25 \\ = 62.5 - 31.25 = 31.25 \text{ kNm}$$

$$\text{B.M. at D,} \quad M_D = 25(3 + 2) - 10 \times 3 \times \left(\frac{3}{2} + 2\right) = 125 - 105 = 20 \text{ kNm}$$

The B.M. between AC and between BD varies according to parabolic law. But B.M. between C and D varies according to straight line law. Now the bending moment diagram is drawn as shown in Fig. 6.30 (c).

**Problem 6.12.** A simply supported beam of length 10 m, carries the uniformly distributed load and two point loads as shown in Fig. 6.31. Draw the S.F. and B.M. diagram for the beam. Also calculate the maximum bending moment.

**Sol.** First calculate the reactions  $R_A$  and  $R_B$ .

Taking moments of all forces about A, we get

$$R_B \times 10 = 50 \times 2 + 10 \times 4 \times \left(2 + \frac{4}{2}\right) + 40(2 + 4) \\ = 100 + 160 + 240 = 500$$

$$\therefore R_B = \frac{500}{10} = 50 \text{ kN}$$

and

$$R_A = \text{Total load on beam} - R_B \\ = (50 + 10 \times 4 + 40) - 50 = 130 - 50 = 80 \text{ kN}$$

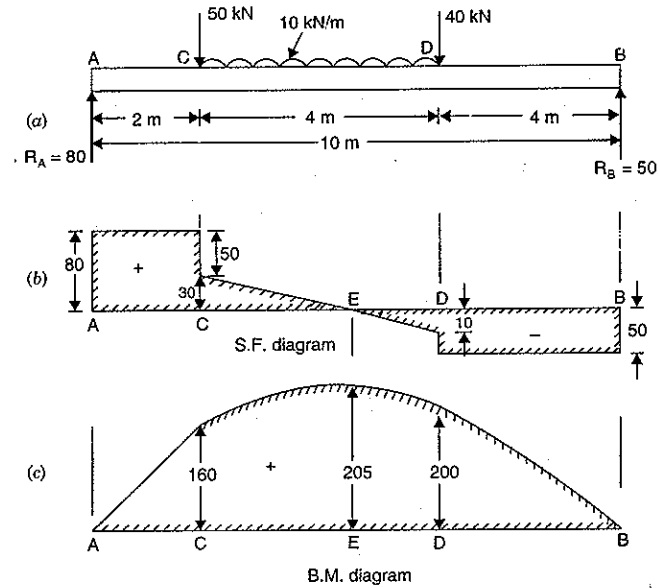

Fig. 6.31

**S.F. Diagram**The S.F. at A,  $F_A = R_A = +80$  kN

The S.F. will remain constant between A and C and equal to + 80 kN

The S.F. just on R.H.S. of C =  $R_A - 50 = 80 - 50 = 30$  kNThe S.F. just on L.H.S. of D =  $R_A - 50 - 10 \times 4 = 80 - 50 - 40 = -10$  kN

The S.F. between C and D varies according to straight line law.

The S.F. just on R.H.S. of D =  $R_A - 50 - 10 \times 4 - 40 = 80 - 50 - 40 - 40 = -50$  kN

The S.F. at B = - 50 kN

The S.F. remains constant between D and B and equal to - 50 kN

The shear force diagram is drawn as shown in Fig. 6.31 (b).

The shear force is zero at point E between C and D.

Let the distance of E from point A is x.

$$\text{Now shear force at E} = R_A - 50 - 10 \times (x - 2) \\ = 80 - 50 - 10x + 20 = 50 - 10x$$

$$\text{But shear force at E} = 0$$

$$\therefore 50 - 10x = 0 \quad \text{or} \quad x = \frac{50}{10} = 5 \text{ m}$$

**B.M. Diagram**

B.M. at A is zero

B.M. at B is zero

$$\text{B.M. at } C, \quad M_C = R_A \times 2 = 80 \times 2 = 160 \text{ kNm}$$

$$\begin{aligned} \text{B.M. at } D, \quad M_D &= R_A \times 6 - 50 \times 4 - 10 \times 4 \times \frac{4}{2} \\ &= 80 \times 6 - 200 - 80 = 480 - 200 - 80 = 200 \text{ kNm} \end{aligned}$$

At  $E$ ,  $x = 5$  m and hence B.M. at  $E$ ,

$$\begin{aligned} M_E &= F_A \times 5 - 50(5-2) - 10 \times (5-2) \times \left(\frac{5-2}{2}\right) \\ &= 80 \times 5 - 50 \times 3 - 10 \times 3 \times \frac{3}{2} = 400 - 150 - 45 = 205 \text{ kNm} \end{aligned}$$

The B.M. between  $C$  and  $D$  varies according to parabolic law reaching a maximum value at  $E$ . The B.M. between  $A$  and  $C$  and also between  $B$  and  $D$  varies according to linear law. The B.M. diagram is shown in Fig. 6.31 (c).

**Maximum B.M.**

The maximum B.M. is at  $E$ , where S.F. becomes zero after changing its sign.

$$\therefore \text{Max. B.M.} = M_E = 205 \text{ kNm. Ans.}$$

### 6.13. SHEAR FORCE AND BENDING MOMENT DIAGRAMS FOR A SIMPLY SUPPORTED BEAM CARRYING A UNIFORMLY VARYING LOAD FROM ZERO AT EACH END TO $w$ PER UNIT LENGTH AT THE CENTRE

Fig. 6.32 shows a beam of length  $L$  simply supported at the ends  $A$  and  $B$  and carrying a uniformly varying load from zero at each end to  $w$  per unit length at the centre. The reactions at the supports will be equal and their magnitude will be half the total load on the entire length, as the load is symmetrical on the beam.

But total load on the beam = Area of load diagram  $ABO$

$$= \frac{AB \times CO}{2} = \frac{L \times w}{2} \text{ or } \frac{w \cdot L}{2}$$

$\therefore R_A = R_B =$  Half the total load

$$= \frac{1}{2} \left( \frac{w \cdot L}{2} \right) = \frac{w \cdot L}{4}$$

Consider any section  $X$  between  $A$  and  $C$  at a distance  $x$  from end  $A$ .

The rate of loading at  $X$

= Vertical distance  $XD$  in load diagram

$$= \frac{x}{\left(\frac{L}{2}\right)} \cdot w \left[ \because \frac{CO}{\left(\frac{L}{2}\right)} = \frac{XD}{x} \therefore XD = \frac{x \times CO}{\left(\frac{L}{2}\right)} = \frac{2x \cdot w}{L} \right]$$

$$= \frac{2w}{L} \cdot x$$

Now load on the length  $AX$  of the beam = Area of load diagram  $AXD$

$$\begin{aligned} &= \frac{x \cdot XD}{2} = \frac{x \cdot \frac{2w}{L} \cdot x}{2} \quad \left( \because XD = \frac{2w}{L} \cdot x \right) \\ &= \frac{w}{L} \cdot x^2 \end{aligned}$$

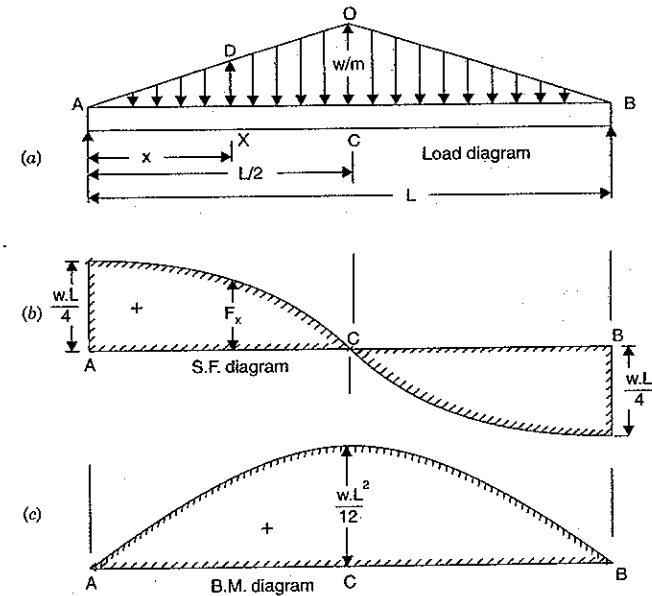

Fig. 6.32

This load is acting at a distance of  $\frac{x}{3}$  from  $X$

Now S.F. at  $X$  is given by,

$$\begin{aligned} F_x &= R_A - \text{load on the length } AX \\ &= \frac{w \cdot L}{4} - \frac{w}{L} x^2 \quad \left( \because R_A = \frac{w \cdot L}{4} \right) \dots (i) \end{aligned}$$

Equation (i) shows that shear force varies according to parabolic law between  $A$  and  $C$ .

$$\text{At } A, x = 0 \text{ hence } F_x = \frac{w \cdot L}{4} - \frac{w}{L} \cdot 0 = \frac{w \cdot L}{4}$$

$$\text{At } C, x = \frac{L}{2} \text{ hence } F_C = \frac{w \cdot L}{4} - \frac{w}{L} \left(\frac{L}{2}\right)^2 = \frac{w \cdot L}{4} - \frac{wL}{4} = 0$$

$$\text{The shear force at } B = -R_B = -\frac{w \cdot L}{4}$$

The shear force is shown in Fig. 6.32 (b). The shear force between  $A$  and  $C$  and also between  $C$  and  $B$  is parabolic.

**B.M. Diagram**

The bending moment is zero at A and B.

The B.M. at X is given by,

$$M_x = R_A \cdot x - \text{Load of length } AX \cdot \frac{x}{3}$$

$$= \frac{w \cdot L}{4} \cdot x - \frac{w}{L} x^2 \cdot \frac{x}{3} = \frac{w \cdot L}{4} \cdot x - \frac{w}{12L} \cdot x^3 \quad \dots(ii)$$

Equation (ii) shows that B.M. between A and C varies according to cubic law.

At A,  $x = 0$  hence  $M_x = 0$

At C,  $x = \frac{L}{2}$  hence  $M_C = \frac{w \cdot L}{4} \cdot \frac{L}{2} - \frac{w}{12L} \cdot \left(\frac{L}{2}\right)^3$

$$= \frac{w \cdot L^2}{8} - \frac{wL^2}{24} = \frac{3w \cdot L^2 - wL^2}{24} = \frac{wL^2}{12}$$

The maximum B.M. occurs at the centre of the beam, where S.F. becomes zero after changing its sign.

∴ Max. B.M. is at C,  $M_C = \frac{wL^2}{12}$

But total load on the beam,  $W = \frac{wL}{2}$

∴ Max. B.M. =  $\frac{wL}{2} \cdot \frac{L}{6} = \frac{w \cdot L}{6}$

**6.14. SHEAR FORCE AND B.M. DIAGRAMS FOR A SIMPLY SUPPORTED BEAM CARRYING A UNIFORMLY VARYING LOAD FROM ZERO AT ONE END TO W PER UNIT LENGTH AT THE OTHER END**

Fig. 6.33 shows a beam AB of length L simply supported at the ends A and B and carrying a uniformly varying load from zero at end A to w per unit length at B. First calculate the reactions  $R_A$  and  $R_B$ .

Taking moments about A, we get

$$R_B \times L = \left(\frac{w \cdot L}{2}\right) \cdot \frac{2}{3} L \quad \left[ \text{Total load} \left( = \frac{w \cdot L}{2} \right) \text{ is acting } \frac{2}{3} L \text{ from } A \right]$$

∴  $R_B = \frac{w \cdot L}{3}$

and

$$R_A = \text{Total load on beam} - R_B = \frac{w \cdot L}{2} - \frac{w \cdot L}{3} = \frac{w \cdot L}{6}$$

Consider any section X at a distance x from end A. The shear force at X is given by,

$$F_x = R_A - \text{load on length } AX = \frac{w \cdot L}{6} - \frac{w \cdot x}{L} \cdot \frac{x}{2}$$

$$\left( \text{Load on } AX = \frac{AX \cdot CX}{2} = \frac{x \cdot w \cdot x}{2 \cdot L} \right)$$

$$= \frac{wL}{6} - \frac{wx^2}{2L} \quad \dots(i)$$

Equation (i) shows that S.F. varies according to parabolic law.

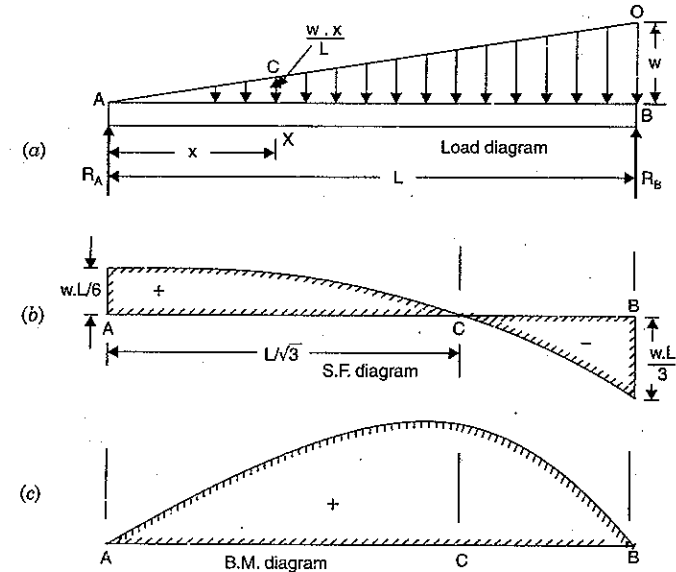

Fig. 6.33

At A,  $x = 0$  hence,  $F_A = \frac{w \cdot L}{6} - \frac{w}{2L} \times 0 = \frac{w \cdot L}{6}$

At B,  $x = L$ , hence,  $F_B = \frac{w \cdot L}{6} - \frac{w \cdot L^2}{2L} = \frac{w \cdot L}{6} - \frac{w \cdot L}{2} = \frac{w \cdot L - 3w \cdot L}{6} = -\frac{2w \cdot L}{6} = -\frac{w \cdot L}{3}$

The shear force is  $+\frac{w \cdot L}{6}$  at A and it decreases to  $-\frac{w \cdot L}{3}$  at B according to parabolic law.

Somewhere between A and B, the S.F. must be zero. Let the S.F. be zero to a distance x from A. Equating the S.F. to zero in equation (i), we get

$$0 = \frac{wL}{6} - \frac{wx^2}{2L} \quad \text{or} \quad \frac{wx^2}{2L} = \frac{w \cdot L}{6}$$

or

$$x^2 = \frac{w \cdot L}{6} \times \frac{2L}{w} = \frac{L^2}{3}$$

∴  $x = \frac{L}{\sqrt{3}} = 0.577 L$

**B.M. Diagram**

The B.M. is zero at A and B.

The B.M. at the section X at a distance x from the end A is given by,

$$M_x = R_A \cdot x - \text{Load on length } AX \cdot \frac{x}{3} \quad \left( \because \text{Load on } AX \text{ is acting at } \frac{x}{3} \text{ from } X \right)$$

$$= \frac{w \cdot L}{6} \cdot x - \frac{wx^2}{2L} \cdot \frac{x}{3} = \frac{wL}{6} \cdot x - \frac{wx^3}{6L}$$

Equation (ii) shows the B.M. varies between A and B according to cubic law.

Max. B.M. occurs at a point where S.F. becomes zero after changing its sign.

That point is at a distance of  $\frac{L}{\sqrt{3}}$  from A. Hence substituting  $x = \frac{L}{\sqrt{3}}$  in equation (ii), we get maximum B.M.

$$\begin{aligned} \therefore \text{Max. B.M.} &= \frac{w \cdot L}{6} \cdot \frac{L}{\sqrt{3}} - \frac{w}{6L} \cdot \left(\frac{L}{\sqrt{3}}\right)^3 \\ &= \frac{wL^2}{6\sqrt{3}} - \frac{wL^2}{18\sqrt{3}} = \frac{3w \cdot L^2 - wL^2}{18\sqrt{3}} = \frac{wL^2}{9\sqrt{3}} \end{aligned}$$

**Problem 6.13.** A simply supported beam of length 5 m carries a uniformly increasing load of 800 N/m run at one end to 1600 N/m run at the other end. Draw the S.F. and B.M. diagrams for the beam. Also calculate the position and magnitude of maximum bending moment.

**Sol.** The loading on the beam is shown in Fig. 6.34. The load may be assumed to be consisting of a uniformly distributed load of 800 N/m over the entire span and a gradually varying load of zero at A to 800 N/m at B.

Then load on beam due to uniformly distributed load of 800 N/m =  $800 \times 5 = 4000$  N

Load on beam due to triangular loading =  $\frac{1}{2} \times 800 \times 5 = 2000$  N

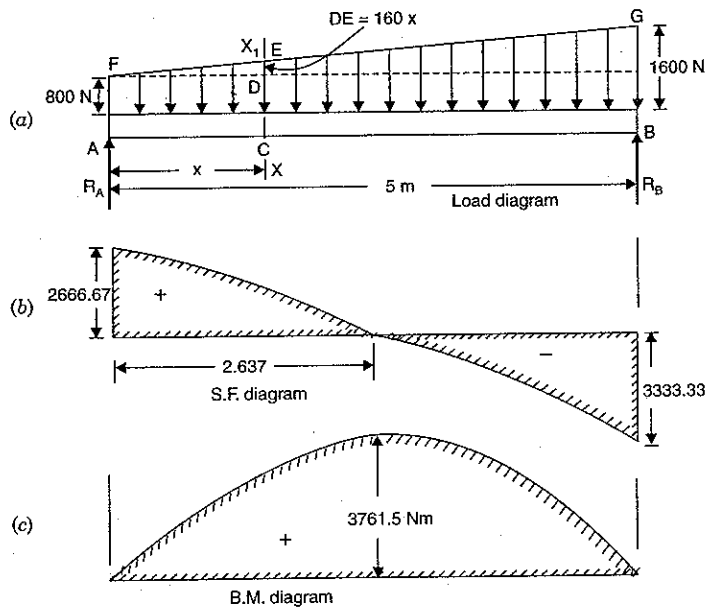

Fig. 6.34

Now calculate the reactions  $R_A$  and  $R_B$ .

Taking the moments about A, we get

$$R_B \times 5 = 4000 \times \frac{5}{2} + 2000 \times \left(\frac{2}{5} \text{ of } 5\right)$$

$$\therefore R_B = 2000 + 1333.33 = 3333.33 \text{ N}$$

and

$$\begin{aligned} R_A &= \text{Total load on beam} - R_B \\ &= (4000 + 2000) - 3333.33 = 2666.67 \text{ N} \end{aligned}$$

Consider any section  $X-X$  at a distance  $x$  from A.

Rate of loading at the section  $X-X$

$$= \text{Length } CE = CD + DE$$

$$= 800 + \frac{x}{5} \times 800 = 800 + 160x$$

Total load on length  $AX$

$$= \text{Area of load diagram } ACDEF$$

$$= \text{Area of rectangle} + \text{Area of } \triangle DEF$$

$$= 800 \times x + \frac{160x \times x}{2} = 800x + 80x^2$$

Now the S.F. at the section  $X-X$  is given by,

$$\begin{aligned} F_x &= R_A - \text{load on length } AX \\ &= 2666.67 - (800x + 80x^2) = 2666.67 - 800x - 80x^2 \end{aligned} \quad \dots(i)$$

Equation (i) shows that shear force varies between A and B according to parabolic law.

$$\text{At A, } x = 0 \text{ hence } F_x = 2666.67 - 800 \times 0 - 80 \times 0 = +2666.67 \text{ N}$$

$$\begin{aligned} \text{At B, } x = 5 \text{ hence } F_x &= 2666.67 - 800 \times 5 - 80 \times 5^2 \\ &= 2666.67 - 4000 - 2000 = -3333.33 \text{ N} \end{aligned}$$

Let us find the position of zero shear. Equating the S.F. equal to zero in equation (i), we get

$$0 = 2666.67 - 800x - 80x^2$$

$$\text{or } x^2 + 10x - \frac{2666.67}{80} = 0 \quad \text{or } x^2 + 10x - 33.33 = 0$$

The above equation is a quadratic equation. Its solution is given by,

$$\begin{aligned} x &= \frac{-10 \pm \sqrt{10^2 + 4 \times 33.33}}{2} = \frac{-10 \pm \sqrt{233.33}}{2} \\ &= \frac{-10 + 15.274}{2} \quad \text{(Neglecting -ve root)} \\ &= 2.637 \text{ m} \end{aligned}$$

**B.M. Diagram**

The B.M. at the section  $X-X$  is given by

$$\begin{aligned} M_x &= R_A \times x - 800 \times x \times \frac{x}{2} - \frac{1}{2} \cdot x \cdot 160x \cdot \frac{x}{3} \\ &= 2666.67x - 400x^2 - \frac{80}{3}x^3 \end{aligned} \quad \dots(ii)$$

Equation (ii) shows that B.M. between A and B varies according to cubic law.

$$\text{At } A, x = 0, \quad M_x = 0$$

$$\text{At } B, x = 5, \quad M_B = 0$$

Maximum B.M. occurs where S.F. is zero. But S.F. is zero at a distance of 2.637 m from A. Hence maximum B.M. is obtained by substituting  $x = 2.637$  m in equation (ii).

$$\therefore \text{Max. B.M.} = 2666.67 \times 2.637 - 400 \times 2.637^2 - \frac{80}{3} \times 2.637^3 = 3761.5 \text{ Nm. Ans.}$$

### 6.15. SHEAR FORCE AND BENDING MOMENT DIAGRAMS FOR OVER-HANGING BEAMS

If the end portion of a beam is extended beyond the support, such beam is known as overhanging beam. In case of overhanging beams, the B.M. is positive between the two supports, whereas the B.M. is negative for the over-hanging portion. Hence at some point, the B.M. is zero after changing its sign from positive to negative or *vice-versa*. That point is known as the *point of contraflexure* or *point of inflexion*.

**6.15.1. Point of Contraflexure.** It is the point where the B.M. is zero after changing its sign from positive to negative or *vice-versa*.

**Problem 6.14.** Draw the shear force and bending moment diagrams for the over-hanging beam carrying uniformly distributed load of 2 kN/m over the entire length as shown in Fig. 6.35. Also locate the point of contraflexure.

**Sol.** First calculate the reactions  $R_A$  and  $R_B$   
Taking moments of all forces about A, we get

$$R_B \times 4 = 2 \times 6 \times \frac{6}{2} = 36 \quad (\because \text{Total load on beam} = 2 \times 6 = 12 \text{ kN. This load is acting at a distance 3 m from A})$$

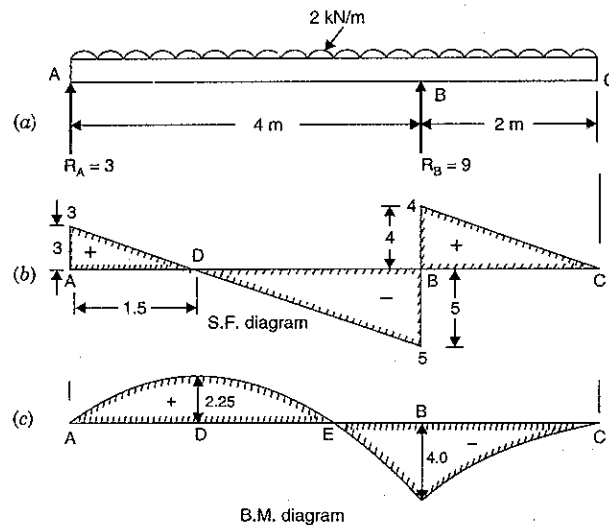

Fig. 6.35

$$R_B = \frac{36}{4} = 9 \text{ kN}$$

and

$$R_A = \text{Total load} - R_B = 2 \times 6 - 9 = 3 \text{ kN}$$

**Shear Force Diagram**

$$\text{Shear force at } A = +R_A = +3 \text{ kN}$$

(i) The shear force at any section between A and B at a distance  $x$  from A is given by,

$$F_A = R_A - 2x \quad (\because R_A = 3) \\ = 3 - 2x \quad \dots(i)$$

$$\text{At } A, x = 0 \text{ hence } F_A = 3 \text{ kN}$$

$$\text{At } B, x = 4 \text{ hence } F_B = 3 - 2 \times 4 = -5 \text{ kN}$$

The shear force varies according to straight line law between A and B. At A, the shear force is positive whereas at B, the shear force is negative. Between A and B somewhere S.F. is zero. The point, where S.F. is zero, is obtained by substituting  $F_x = 0$  in equation (i).

$$0 = 3 - 2x \quad \text{or } x = \frac{3}{2} = 1.5 \text{ m}$$

Hence S.F. is zero at a distance of 1.5 m from A (or S.F. is zero at point D).

(ii) The S.F. at any section between B and C at a distance  $x$  from A is given by,

$$F_x = +R_A - 4 \times 2 + R_B - (x - 4) \times 2 = 3 - 8 + 9 - 2(x - 4) \\ = 4 - 2(x - 4) \quad \dots(ii)$$

$$\text{At } B, x = 4 \text{ m hence } F_B = 4 - 2(4 - 4) = +4 \text{ kN}$$

$$\text{At } C, x = 6 \text{ m hence } F_C = 4 - 2(6 - 4) = 0$$

Between B and C also S.F. varies by a straight line law. At B, S.F. is +4 kN and at C, S.F. is zero.

The S.F. diagram is shown in Fig. 6.35 (b).

**B.M. Diagram**

The B.M. at A is zero.

(i) The B.M. at any section between A and B at a distance  $x$  is given by,

$$M_x = R_A \times x - 2 \times x \times \frac{x}{2} \\ = 3x - x^2 \quad \dots(iii)$$

$$\text{At } A, x = 0 \text{ hence } M_A = 0$$

$$\text{At } B, x = 4 \text{ hence } M_B = 3 \times 4 - 4^2 = -4 \text{ kNm}$$

Max. B.M. occurs at D, where S.F. is zero after changing its sign.

$$\text{At } D, x = 1.5 \text{ hence } M_D = 3 \times 1.5 - 1.5^2 = 4.5 - 2.25 = 2.25 \text{ kNm}$$

The B.M. between A and B varies according to parabolic law.

(ii) The B.M. at any section between B and C at a distance  $x$  is given by,

$$M_x = R_A \times x - 2 \times x \times \frac{x}{2} + R_B \times (x - 4) \\ = 3x - x^2 + 9(x - 4) \quad \dots(iv)$$

$$\text{At } B, x = 4 \text{ hence } M_B = 3 \times 4 - 4^2 + 9(4 - 4) = 4 \text{ kNm}$$

$$\text{At } C, x = 6 \text{ hence } M_C = 3 \times 6 - 6^2 + 9(6 - 4) = 18 - 36 + 18 = 0$$

The B.M. diagram is shown in Fig. 6.35 (c).

**Point of Contraflexure**

This point will be between A and B where B.M. is zero after changing its sign. But B.M. at any section at a distance  $x$  from A between A and B is given by equation (iii) as

$$M_x = 3x - x^2$$

Equation  $M_x$  to zero for point of contraflexure, we get

$$0 = 3x - x^2 = x(3 - x)$$

or  $3 - x = 0$  ( $\because x$  cannot be zero as B.M. is not changing sign at this point)

$$x = 3$$

Hence point of contraflexure will be at a distance of 3 m from A.

**Problem 6.15.** Draw the S.F. and B.M. diagrams for the overhanging beam carrying uniformly distributed load of 2 kN/m over the entire length and a point load of 2 kN as shown in Fig. 6.36. Locate the point of contraflexure.

**Sol.** First calculate the reactions  $R_A$  and  $R_B$ .

Taking moments of all forces about A, we get

$$R_B \times 4 = 2 \times 6 \times 3 + 2 \times 6 = 36 + 12 = 48$$

$$R_B = \frac{48}{4} = 12 \text{ kN}$$

and

$$R_A = \text{Total load} - R_B = (2 \times 6 + 2) - 12 = 2 \text{ kN}$$

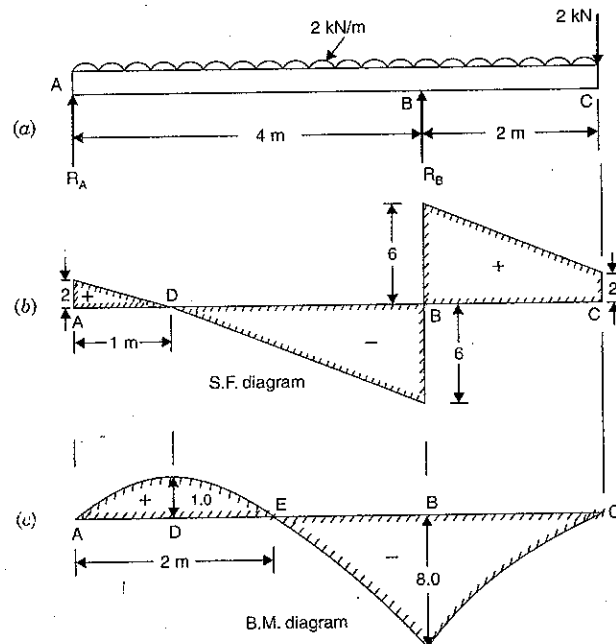

Fig. 6.36

**S.F. Diagram**

$$\text{S.F. at A} = +R_A = +2 \text{ kN}$$

(i) The S.F. at any section between A and B at a distance  $x$  from A is given by,

$$F_x = +R_A - 2 \times x = 2 - 2x \quad \dots(i)$$

$$\text{At A, } x = 0 \text{ hence } F_A = 2 - 2 \times 0 = 2 \text{ kN}$$

$$\text{At B, } x = 4 \text{ hence } F_B = 2 - 2 \times 4 = -6 \text{ kN}$$

The S.F. between A and B varies according to straight line law. At A, S.F. is positive and at B, S.F. is negative. Hence between A and B, S.F. is zero. The point of zero S.F. is obtained by substituting  $F_x = 0$  in equation (i).

$$\therefore 0 = 2 - 2x \text{ or } x = \frac{2}{2} = 1 \text{ m}$$

The S.F. is zero at point D. Hence distance of D from A is 1 m.

(ii) The S.F. at any section between B and C at a distance  $x$  from A is given by,

$$F_x = +R_A - 2 \times 4 + R_B - 2(x - 4) = 2 - 8 + 12 - 2(x - 4) = 6 - 2(x - 4) \quad \dots(ii)$$

$$\text{At B, } x = 4 \text{ hence } F_B = 6 - 2(4 - 4) = +6 \text{ kN}$$

$$\text{At C, } x = 6 \text{ hence } F_C = 6 - 2(6 - 4) = 6 - 4 = 2 \text{ kN}$$

The S.F. diagram is drawn as shown in Fig. 6.36 (b).

**B.M. Diagram**

B.M. at A is zero

(i) B.M. at any section between A and B at a distance  $x$  from A is given by,

$$M_x = R_A \times x - 2 \times x \times \frac{x}{2} = 2x - x^2 \quad \dots(iii)$$

The above equation shows that the B.M. between A and B varies according to parabolic law.

$$\text{At A, } x = 0 \text{ hence } M_A = 0$$

$$\text{At B, } x = 4 \text{ hence } M_B = 2 \times 4 - 4^2 = -8 \text{ kNm}$$

Max. B.M. is at D where S.F. is zero after changing sign

$$\text{At D, } x = 1 \text{ hence } M_D = 2 \times 1 - 1^2 = 1 \text{ kNm}$$

The B.M. at C is zero. The B.M. also varies between B and C according to parabolic law. Now the B.M. diagram is drawn as shown in Fig. 6.36 (c).

**Point of Contraflexure**

This point is at E between A and B, where B.M. is zero after changing its sign. The distance of E from A is obtained by putting  $M_x = 0$  in equation (iii).

$$0 = 2x - x^2 = x(2 - x)$$

$$2 - x = 0$$

and

$$x = 2 \text{ m. Ans.}$$

**Problem 6.16.** A beam of length 12 m is simply supported at two supports which are 8 m apart, with an overhang of 2 m on each side as shown in Fig. 6.37. The beam carries a concentrated load of 1000 N at each end. Draw S.F. and B.M. diagrams.



**Sol.** As the loading on the beam is symmetrical. Hence reactions  $R_A$  and  $R_B$  will be equal and their magnitude will be half of the total load.

$$\therefore R_A = R_B = \frac{(1000 + 1000)}{2} = 1000 \text{ N}$$

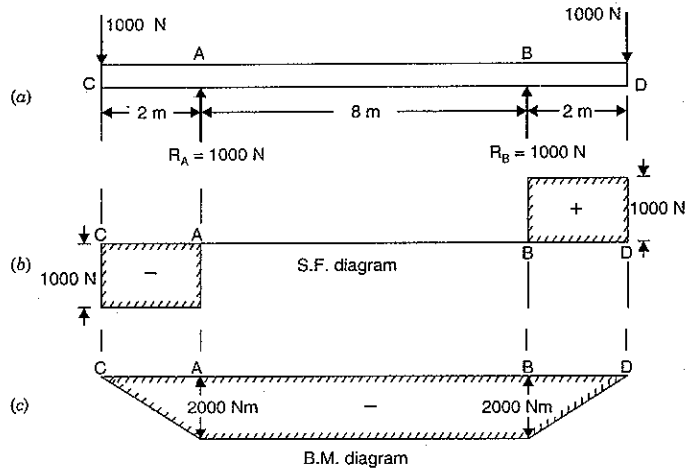

Fig. 6.37

S.F. at C = - 1000 N  
 S.F. remains constant (i.e., = - 1000 N) between C and A  
 S.F. at A = - 1000 +  $R_A$  = - 1000 + 1000 = 0  
 S.F. remains constant (i.e., = 0) between A and B  
 S.F. at B = 0 + 1000 = + 1000 N  
 S.F. remains constant (i.e., = 1000 N) between B and D  
 S.F. diagrams is drawn as shown in Fig. 6.37 (b).

#### B.M. Diagram

B.M. at C = 0  
 B.M. at A = - 1000 × 2 = - 2000 Nm (- ve sign is due to hogging moment)  
 B.M. between C and A varies according to straight line law.  
 The B.M. at any section in AB at a distance of  $x$  from C is given by,  

$$M_x = - 1000 \times x + R_A(x - 2)$$

$$= - 1000 \times x + 1000(x - 2) = - 2000 \text{ Nm}$$

Hence B.M. between A and B is constant and equal to - 2000 Nm.

B.M. at D = 0.

$\therefore$  B.M. diagram is shown in Fig. 6.37 (c).

**Note.** In this particular case, the S.F. is zero between AB and B.M. is constant. Hence length AB is subjected to only constant B.M. The length between A and B is absolutely free from shear force.

**Problem 6.17.** Draw the S.F. and B.M. diagrams for the beam which is loaded as shown in Fig. 6.38. Determine the points of contraflexure within the span AB.

**Sol.** First calculate the reactions  $R_A$  and  $R_B$ .

Taking moments about A, we have

$$R_B \times 8 + 800 \times 3 = 2000 \times 5 + 1000(8 + 2)$$

$$\text{or } 8R_B + 2400 = 10000 + 10000$$

$$\therefore R_B = \frac{20000 - 2400}{8} = \frac{17600}{8} = 2200 \text{ N}$$

$$\text{and } R_A = \text{Total load} - R_B = 3800 - 2200 = 1600$$

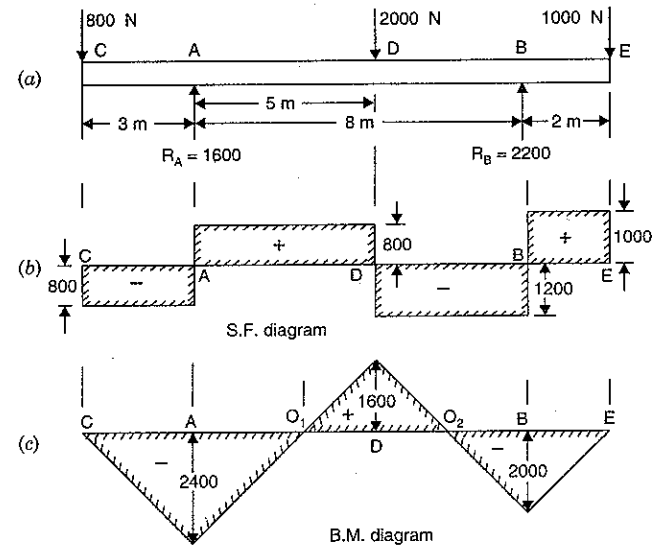

Fig. 6.38

#### S.F. Diagram

S.F. at C = - 800 N  
 S.F. between C and A remains - 800 N  
 S.F. at A = - 800 +  $R_A$  = - 800 + 1600 = + 800 N  
 S.F. between A and D remains + 800 N  
 S.F. at D = + 800 - 2000 = - 1200 N  
 S.F. between D and B remains - 1200 N  
 S.F. at B = - 1200 +  $R_B$  = - 1200 + 2200 = + 1000 N  
 S.F. between B and E remains + 1000 N  
 S.F. diagram is shown in Fig. 6.38.

**B.M. Diagram**

$$\begin{aligned} \text{B.M. at C} &= 0 \\ \text{B.M. at A} &= -800 \times 3 = -2400 \text{ Nm} \\ \text{B.M. at D} &= -800 \times (3+5) + R_A \times 5 \\ &= -800 \times 8 + 1600 \times 5 \\ &= -6400 + 8000 = +1600 \text{ Nm} \\ \text{B.M. at B} &= -1000 \times 2 = -2000 \text{ Nm} \\ \text{B.M. at E} &= 0 \end{aligned}$$

The B.M. diagram is drawn as shown in Fig. 6.38 (c).

**Points of Contraflexure**

There will be two points of contraflexure  $O_1$  and  $O_2$ , where B.M. becomes zero after changing its sign. Point  $O_1$  lies between A and D, whereas the point  $O_2$  lies between D and B.

(i) Let the point  $O_1$  is  $x$  metre from A.

$$\begin{aligned} \text{Then B.M. at } O_1 &= -800(3+x) + R_A \times x = -800(3+x) + 1600x \\ &= -2400 - 800x + 1600x = -2400 + 800x \end{aligned}$$

But B.M. at  $O_1$  is zero

$$\therefore \quad 0 = -2400 + 800x \quad \text{or} \quad x = \frac{2400}{800} = 3 \text{ m. Ans.}$$

(ii) Let the point  $O$  be  $x$  metre from B.

$$\text{Then B.M. at } O_2 = 1000(x+2) - R_B \times x = 1000x + 2000 - 2200 \times x = 2000 - 1200x$$

But B.M. at  $O_2 = 0$

$$\therefore \quad 0 = 2000 - 1200x$$

$$\therefore \quad x = \frac{2000}{1200} = \frac{5}{3} = 1.67 \text{ m from B. Ans.}$$

**Problem 6.18.** A horizontal beam 10 m long is carrying a uniformly distributed load of 1 kN/m. The beam is supported on two supports 6 m apart. Find the position of the supports, so that B.M. on the beam is as small as possible. Also draw the S.F. and B.M. diagrams.

**Sol.** The beam CD is 10 m long. Let the two supports 6 m apart are at A and B.

Let  $x$  = Distance of support A from C in metre

Then distance of support B from end D

$$= 10 - (6+x) = (4-x) \text{ m}$$

First calculate the reactions  $R_A$  and  $R_B$ .

Taking moments about A, we get

$$1 \times x \times \frac{x}{2} + R_B \times 6 = (10-x) \times 1 \times \frac{(10-x)}{2}$$

$$\text{or} \quad \frac{x^2}{2} + 6R_B = \frac{(10-x)^2}{2} \quad \text{or} \quad x^2 + 12R_B = (10-x)^2 = 100 + x^2 - 20x$$

$$\text{or} \quad 12R_B = 100 + x^2 - 20x - x^2 = 100 - 20x$$

$$\therefore \quad R_B = \frac{100 - 20x}{12} = \frac{4(25 - 5x)}{12} = \frac{1}{3} (25 - 5x) = \frac{5}{3} (5 - x)$$

and

$$\begin{aligned} R_A &= \text{Total load} - R_B \\ &= 10 \times 1 - \frac{5}{3} (5-x) = \frac{30 - 25 + 5x}{3} \\ &= \frac{5 + 5x}{3} = \frac{5}{3} (1+x) \end{aligned}$$

In the present case of overhanging beam, the maximum negative B.M. will be at either of the two supports and the maximum positive B.M. will be in the span AB. If the B.M. on the beam is as small as possible, then the length of the overhanging portion should be so adjusted that the maximum negative B.M. at the support is equal to the maximum positive B.M. in the span AB.

The B.M. will be maximum in the span AB at a point where S.F. is zero.

Let B.M. is maximum (or S.F. is zero) at a section in AB at a distance of  $y$  m from C.

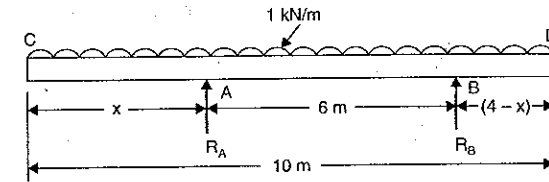

Fig. 6.39

But S.F. at this section =  $y \times 1 - R_A$

$$\therefore \quad y \times 1 - R_A = 0$$

$$\text{or} \quad y \times 1 - \frac{5}{3} (1+x) = 0$$

$$\therefore \quad y = \frac{5}{3} (1+x) \quad \dots(i)$$

Now B.M. at the support A

$$= -1 \times x \times \frac{x}{2} = -\frac{x^2}{2} \quad \dots(ii)$$

and B.M. at a distance  $y$  from C

$$= -1 \times y \times \frac{y}{2} + R_A \times (y-x)$$

$$= -\frac{y^2}{2} + \frac{5}{3} (1+x)(y-x) \quad \left[ \because R_A = \frac{5}{3} (1+x) \right]$$

$$= -\frac{1}{2} \left[ \frac{5}{3} (1+x) \right]^2 + \frac{5}{3} (1+x) \left[ \frac{5}{3} (1+x) - x \right] \quad \left[ \because y = \frac{5}{3} (1+x) \right]$$

$$= \frac{5}{3} (1+x) \left[ -\frac{5(1+x)}{3 \times 2} + \frac{5}{3} (1+x) - x \right]$$

$$= \frac{5}{3} (1+x) \left[ \frac{-5 - 5x + 10 + 10x - 6x}{6} \right]$$

$$= \frac{5}{3} (1+x) \left[ \frac{5-x}{6} \right] = \frac{5}{18} (-x^2 + 4x + 5) \quad \dots(iii)$$

For the condition that the B.M. shall be as small as possible, the hogging moment at the support A and the maximum sagging moment in the span AB should be numerically equal.

∴ Equating equations (ii) and (iii) and ignoring the -ve sign of B.M. at A, we get

$$\therefore \frac{5}{18}(-x^2 + 4x + 5) = \frac{x^2}{2}$$

or  $-5x^2 + 20x + 25 = 9x^2$  or  $14x^2 - 20x - 25 = 0$

The above equation is a quadratic equation. Hence its solution is given by

$$x = \frac{20 \pm \sqrt{20^2 + 4 \times 14 \times 25}}{2 \times 14} = \frac{20 \pm \sqrt{400 + 1400}}{28} = \frac{20 \pm 42.42}{28}$$

$$= \frac{20 \pm 42.42}{28} \quad (\text{Neglecting } -ve \text{ value})$$

$$= 2.23 \text{ m}$$

Substituting this value of  $x$  in equation (i), we get

$$y = \frac{5}{3}(1 + 2.23) = \frac{5 \times 3.23}{3} = 5.38 \text{ m}$$

Now the values of reactions  $R_A$  and  $R_B$  are obtained as :

$$R_A = \frac{5}{3}(1 + x) = \frac{5}{3}(1 + 2.23) = 5.38 \text{ kN}$$

and

$$R_B = \frac{5}{3}(5 - x) = \frac{5}{3}(5 - 2.23) = 4.62 \text{ kN}$$

Now the S.F. and B.M. diagrams can be drawn as shown in Fig. 6.40.

#### S.F. Diagram

S.F. at C = 0

S.F. just on L.H.S. of A =  $-1 \times 2.23 = -2.23 \text{ kN}$

Shear force varies between C and A by a straight line law.

S.F. just on L.H.S. of A =  $-2.23 + R_A$   
 $= -2.23 + 5.38 = +3.15 \text{ kN}$

S.F. just on L.H.S. of B =  $+3.15 - 1 \times 6 = -2.85 \text{ kN}$

Shear force between A and B varies by a straight line law.

S.F. just on R.H.S. of B =  $-2.85 + R_B$   
 $= -2.85 + 4.62 = +1.17 \text{ kN}$

S.F. at D =  $1.17 - 1 \times 1.77 = 0$

S.F. between B and D varies by a straight line law.

S.F. diagram is drawn as shown in Fig. 6.40 (c).

#### B.M. Diagram

B.M. at C = 0

B.M. at A =  $-1 \times 2.23 \times \frac{2.23}{2} = -2.49 \text{ kNm}$

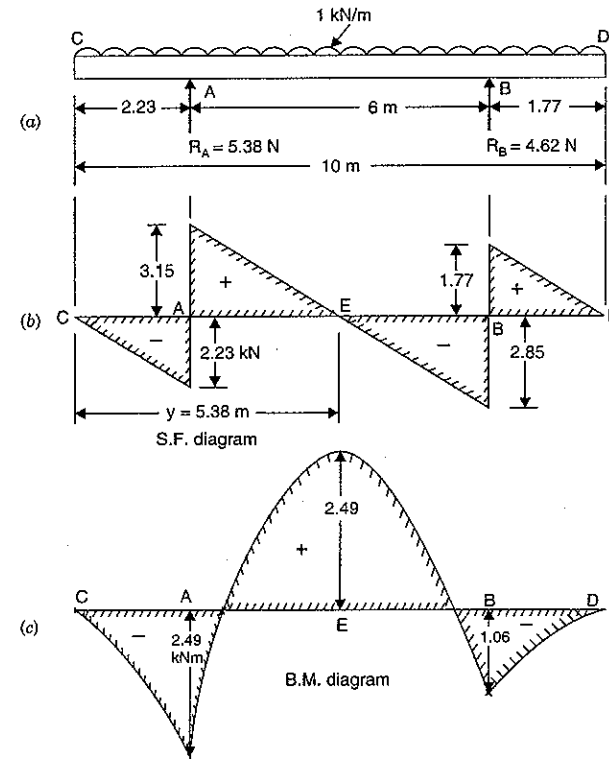

Fig. 6.40

B.M. at E (i.e., at a distance  $y = 5.38 \text{ m}$  from point C)

$$= -1 \times 5.38 \times \frac{5.38}{2} + R_A \times (5.38 - 2.23)$$

$$= -\frac{5.38^2}{2} + 5.38 \times 3.15 = 2.49 \text{ kNm}$$

B.M. at B =  $-1 \times 1.77 \times \frac{1.77}{2} = -1.06 \text{ kNm}$

The B.M. between C and A; between A and B; and between B and D varies according to parabolic law. B.M. diagram is shown in Fig. 6.40 (c).

#### 6.16. S.F. AND B.M. DIAGRAMS FOR BEAMS CARRYING INCLINED LOAD

The shear force is defined as the algebraic sum of the vertical forces at any section of a beam to the right or left of the section. But when a beam carries inclined loads, then these inclined loads are resolved into their vertical and horizontal components. The vertical components only will cause shear force and bending moments.

The horizontal components of the inclined loads will introduce axial force or thrust in the beam. The variation of axial force for all sections of the beam can be shown by a diagram known as *thrust diagram* or *axial force diagram*.

In most of the cases, one end of the beam is hinged and the other end is supported on rollers. The roller support cannot provide any horizontal reaction. Hence only the hinged end will provide the horizontal reaction.

**Problem 6.19.** A horizontal beam AB of length 4 m is hinged at A and supported on rollers at B. The beam carries inclined loads of 100 N, 200 N and 300 N inclined at 60°, 45° and 30° to the horizontal as shown in Fig. 6.41. Draw the S.F., B.M. and thrust diagrams for the beam.

**Sol.** First of all, resolve the inclined loads into their vertical and horizontal components.

The inclined load at C is having horizontal component

$$= 100 \times \cos 60^\circ = 100 \times 0.5 = 50 \text{ N,}$$

whereas the vertical component  $= 100 \times \sin 60^\circ = 100 \times 0.866 = 86.6 \text{ N}$

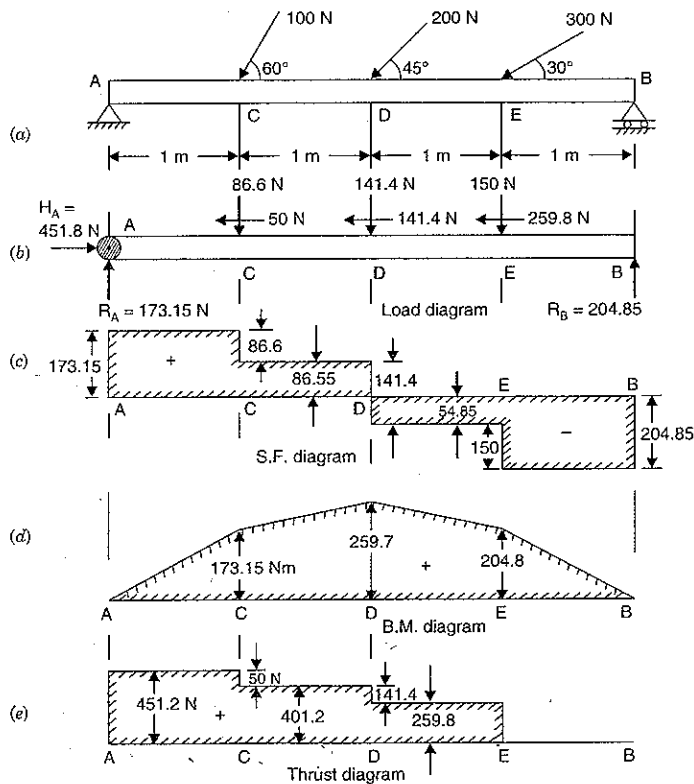

Fig. 6.41

Similarly the inclined load at D is having horizontal component

$$= 200 \times \cos 45^\circ = 141.4 \text{ N,}$$

whereas the vertical component  $= 200 \times \sin 45^\circ = 141.4 \text{ N}$

The inclined load at E is having horizontal component

$$= 300 \times \cos 30^\circ = 300 \times 0.866 = 259.8 \text{ N,}$$

whereas the vertical component  $= 300 \times \sin 30^\circ = 150 \text{ N}$

The horizontal and vertical components of all inclined loads are shown in Fig. 6.41 (b).

As beam is supported on rollers at B, hence roller support at B will not provide any horizontal reaction. The horizontal reaction will be only provided by hinged end A.

Let  $H_A$  = Horizontal reaction at A  
 $=$  Sum of all horizontal components of inclined loads  
 $= 50 + 141.4 + 259.8$   
 (All horizontal components are acting in the same direction)  
 $= 451.20 \text{ N}$

To find the reactions  $R_A$  and  $R_B$ , take the moments of all forces about A,

$$\therefore R_B \times 4 = 86.6 \times 1 + 141.4 \times 2 + 150 \times 3 = 819.4$$

$$\text{or } R_B = \frac{819.4}{4} = 204.85 \text{ N}$$

$$\therefore R_A = \text{Total vertical load} - R_B$$

$$= (86.6 + 141.4 + 150) - 204.85 = 173.15 \text{ N}$$

#### S.F. Diagram

The S.F. is due to vertical loads (including vertical reactions) only.

S.F. at A  $= +R_A = +173.15 \text{ N}$

S.F. remains constant between A and C and equal to 173.15 N

S.F. suddenly changes at C due to point load and S.F. at C

$$= 173.15 - 86.6 = 86.55 \text{ N}$$

S.F. remains constant between C and D and is equal to 86.55 N

S.F. at D  $= 86.55 - 141.40 = -54.85 \text{ N}$

The S.F. remains constant between E and D and is equal to  $-54.85 \text{ N}$

The S.F. at B  $= -54.85 - 150.00 = -204.85 \text{ N}$

The S.F. diagram is shown in Fig. 6.41 (c).

#### B.M. Diagram

The B.M. is only due to vertical loads (including vertical reactions) only.

The B.M. at A  $= 0$

B.M. at C  $= R_A \times 1 = 173.15 \times 1 = 173.15 \text{ Nm}$

B.M. at D  $= R_A \times 2 - 86.6 \times 1$

$$= 173.15 \times 2 - 86.6 = 259.7 \text{ Nm}$$

B.M. at E  $= R_A \times 3 - 86.6 \times 2 - 141.4 \times 1$

$$= 173.15 \times 3 - 86.6 \times 2 - 141.4 = +204.85 \text{ Nm}$$

B.M. at B  $= 0$

The B.M. diagram is shown in Fig. 6.41 (d).

**Thrust Diagram or Axial Force Diagram**

The thrust diagram is due to horizontal components including horizontal reaction.

Axial force at A = +  $H_A$  = 451.20 N

The axial force remains constant between A and C and is equal to 451.20 N

Axial force at C =  $H_A - 50$  = 451.20 - 50 = 401.2 N

Axial force remains constant between C and D and is equal to 401.2 N

Axial force at D = 401.2 - 141.40 = 259.8 N

Axial force remains constant between D and E and is equal to 259.8 N

Axial force at E = 259.8 - 259.8 = 0

Axial force between E and B is zero.

Thrust diagram or axial force diagram is shown in Fig. 6.41 (e).

**Problem 6.20.** A horizontal beam AB of length 8 m is hinged at A and placed on rollers at B. The beam carries three inclined point loads as shown in Fig. 6.42. Draw the S.F., B.M. and axial force diagrams of the beam.

**Sol.** First resolve the inclined loads into their vertical and horizontal components.

Vertical component of force at C  
 =  $4 \sin 30^\circ = 4 \times 0.5 = 2 \text{ kN}$

Horizontal component of force at C  
 =  $4 \times \cos 30^\circ = 4 \times 0.866 = 3.464 \text{ kN} \rightarrow$

Vertical component of force at D  
 =  $8 \times \sin 60^\circ = 8 \times 0.866 = 6.928 \text{ kN}$

Horizontal component of force at D  
 =  $8 \times \cos 60^\circ = 8 \times 0.5 = 4 \text{ kN} \leftarrow$

Vertical component of force at E  
 =  $6 \times \sin 45^\circ = 6 \times 0.707 = 4.242 \text{ kN}$

Horizontal component of force at E  
 =  $6 \times \cos 45^\circ = 6 \times 0.707 = 4.242 \text{ kN} \leftarrow$

The horizontal and vertical components of all inclined loads are shown in Fig. 6.42 (b).

The horizontal reaction will be provided by the hinged end A.

$\therefore$  Horizontal reaction at A,

$$H_A = -3.464 + 4 + 4.242 = 4.778 \text{ kN}$$

To find vertical reactions  $R_A$  and  $R_B$ , take the moments of all forces about A.

$$\therefore R_B \times 8 = 2 \times 2 + 6.928 \times 4 + 4.242 \times 6 = 57.164$$

$$\therefore R_B = \frac{57.164}{8} = 7.1455 \text{ kN}$$

Now  $R_A = \text{Total vertical loads} - R_B$   
 =  $(2 + 6.928 + 4.242) - 7.1455 = 6.0245 \text{ kN}$

**S.F. Diagram**

S.F. is due to vertical loads

S.F. at A = +  $R_A$  = + 6.0245 kN

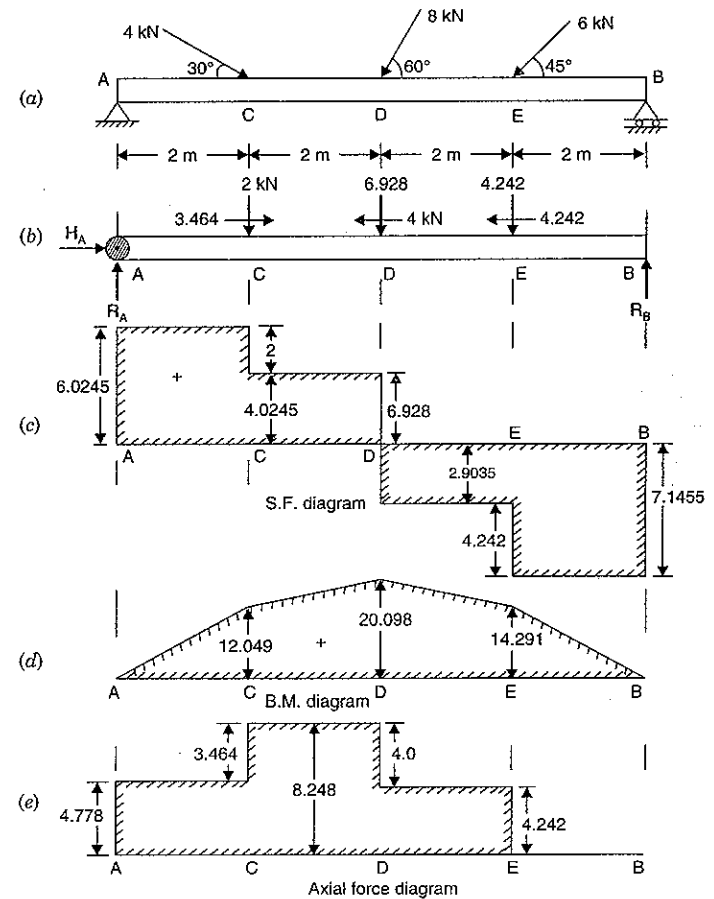

Fig. 6.42

S.F. remains 6.0245 kN between A and C

S.F. at C = + 6.0245 - 2 = + 4.0245 kN

S.F. remains 4.0245 kN between C and D

S.F. at D = + 4.0245 - 6.928 = - 2.9035 kN

S.F. remains - 2.9035 kN between D and E

S.F. at E = - 2.9035 - 4.242 = - 7.1455 kN

S.F. remains constant between E and B and equal to - 7.1455

S.F. diagram is shown in Fig. 6.42 (c).

**B.M. Diagram**

B.M. is only due to vertical loads

$$\text{B.M. at } A = 0$$

$$\text{B.M. at } C = R_A \times 2 = 6.0245 \times 2 = 12.049 \text{ kNm}$$

$$\text{B.M. at } D = 6.0245 \times 4 - 2 \times 2 = 20.098 \text{ kNm}$$

$$\text{B.M. at } E = 6.0245 \times 6 - 2 \times 4 - 6.928 \times 2 = 14.291 \text{ kNm}$$

$$\text{B.M. at } B = 0$$

B.M. diagram is shown in Fig. 6.42 (d).

**Axial Force Diagram**

Axial force is due to horizontal components including horizontal reaction.

$$\text{Axial force at } A = + H_A = + 4.778 \text{ kN}$$

Axial force remains 4.778 kN between A and C

$$\text{Axial force at } C = + 4.778 + 3.464 = + 8.242$$

Axial force remains 8.242 kN between C and D

$$\text{Axial force at } D = 8.242 - 4.0 = + 4.242$$

Axial force remains 4.242 kN between D and E

$$\text{Axial force at } E = + 4.242 - 4.242 = 0$$

Axial force remains zero between E and B

Axial force diagram is shown in Fig. 6.42 (e).

### 6.17. SHEAR FORCE AND BENDING MOMENT DIAGRAMS FOR BEAMS SUBJECTED TO COUPLES

When a beam is subjected to a couple at a section, only the bending moment at the section of the couple changes suddenly in magnitude equal to that of the couple. But the S.F. does not change at the section of the couple as there is no change in load due to couple at the section. But while calculating the reactions, the magnitude of the couple is taken into account.

The sudden change in B.M. at the section of the couple can also be obtained by calculating B.M. separately with the help of both the reactions.

**Problem 6.21.** A simply supported beam AB of length 6 m is hinged at A and B. It is subjected to a clockwise couple of 24 kNm at a distance of 2 m from the left end A. Draw the S.F. and B.M. diagrams.

**Sol.** Fig. 6.43 (a) shows the simply supported beam AB, hinged at A and B. The clockwise couple at C will try to lift the beam up at the support A, and to depress the beam down at the support B. Hence the reaction at A will be downwards and at B the reaction will be upwards as shown in Fig. 6.43 (b).

To find reactions of  $R_A$  and  $R_B$ , take the moments about A.

$$\therefore R_B \times 6 - 24 = 0 \quad (\because \text{Moment due to } R_B \text{ is anti-clockwise and moment at } C \text{ is clockwise})$$

$$\therefore R_B = \frac{24}{6} = 4 \text{ kN } \uparrow$$

Since there is no external vertical load on the beam, therefore the reaction at A will be the same, as that of B, but in opposite direction.

$$\therefore R_A = \text{Load on beam} - R_B \quad (\because \text{Load on beam} = 0)$$

$$= - R_B = - 4 \text{ kN.}$$

**S.F. Diagram**

$$\text{S.F. at } A = R_A = - 4 \text{ kN}$$

The S.F. remains constant (i.e., equal to - 4 kN) between A and B.

The S.F. diagram is shown in Fig. 6.43 (c).

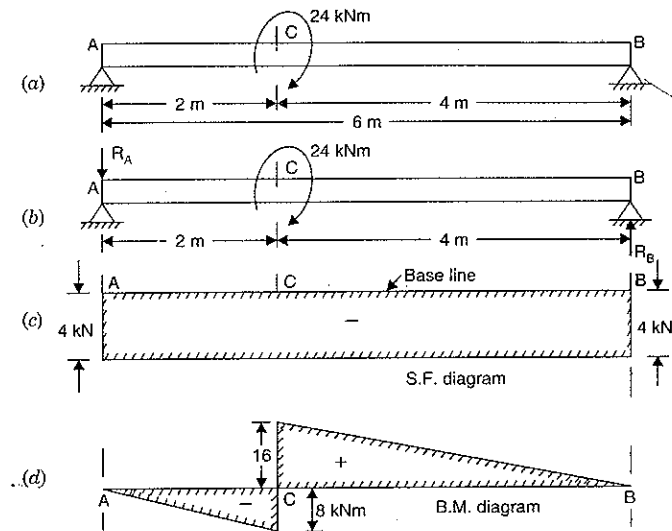

Fig. 6.43

**B.M. Diagram**

$$\text{B.M. at } A = 0$$

$$\text{B.M. just on the L.H.S. of } C = R_A \times 2 = - 4 \times 2 = - 8 \text{ kNm}$$

$$\text{B.M. just on the R.H.S. of } C = R_B \times 4 = 4 \times 4 = + 16 \text{ kNm}$$

(B.M. just on the R.H.S. of C can also be calculated as the sum of moments due to  $R_A$  and moment due to couple. But moment due to  $R_A$  is anti-clockwise whereas due to couple is clockwise. Hence net B.M. on R.H.S. of C = - 8 + 24 = + 16 kNm).

There is a sudden change in B.M. at C due to couple.

$$\text{B.M. at } B = 0$$

B.M. diagram is shown in Fig. 6.43 (d).

**Problem 6.22.** A beam 10 m long and simply supported at each end, has a uniformly distributed load of 1000 N/m extending from the left end upto the centre of the beam. There is also an anti-clockwise couple of 15 kNm at a distance of 2.5 m from the right end. Draw the S.F. and B.M. diagrams.

**Sol.** The reaction at A will be upwards. To find whether the reaction at B is upwards or downwards, take the moments about A.

The following are the moments at A :

$$(i) \text{ Moment due to U.D.L.} = 1000 \times 5 \times \frac{5}{2} = 12500 \text{ Nm (clockwise)}$$

- (ii) Moment of couple = 15000 Nm (Anti-clockwise)  
 $\therefore$  Net moment = 15000 - 12500  
 = 2500 Nm (Anti-clockwise)

This moment must be balanced by the moments due to reaction at  $B$ . Hence the moment about  $A$  due to reaction at  $B$  should be equal to 2500 Nm (clockwise). This is only possible when  $R_B$  is acting downwards. This is shown in Fig. 6.44 (b).

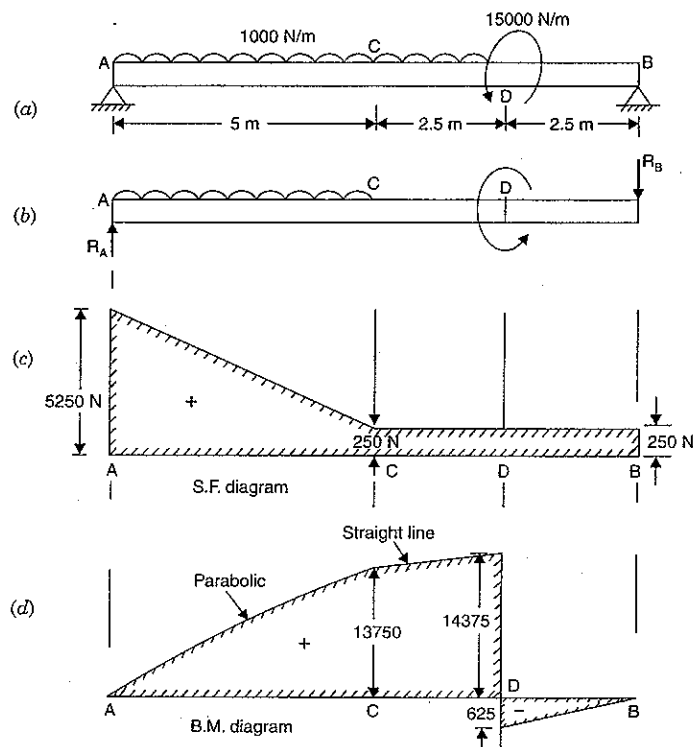

Fig. 6.44

$$\therefore R_B \times 10 = 2500$$

$$\therefore R_B = \frac{2500}{10} = 250 \text{ N}$$

and

$$R_A = \text{Total load on beam} + R_B$$

(Here  $R_B$  is +ve as acting downwards)

$$= 1000 \times 5 + 250 = 5250 \text{ N.}$$

**S.F. Diagram**

- S.F. at  $A$  = +  $R_A$  = 5250 N  
 S.F. at  $C$  = 5250 - 5 × 1000 = + 250 N  
 S.F. between  $A$  and  $C$  varies according to straight line law.  
 S.F. between  $C$  and  $B$  remains constant and equal to + 250 N  
 S.F. diagram is shown in Fig. 6.44 (c).

**B.M. Diagram**

- B.M. at  $A$  = 0  
 B.M. at  $C$  =  $R_A \times 5 - 1000 \times 5 \times \frac{5}{2}$   
 = 5250 × 5 - 12500 = 13750 Nm  
 B.M. just on the left hand side of  $D$   
 = 5250 × 7.5 - 1000 × 5 ×  $\left(\frac{5}{2} + 2.5\right)$   
 = 39375 - 25000 = 14375 Nm  
 B.M. just on the right hand side of  $D$   
 = -  $R_B \times 2.5$  = - 250 × 2.5 = - 625 Nm  
 B.M. at  $B$  = 0  
 The B.M. diagram is shown in Fig. 6.44 (d).

**6.18. RELATIONS BETWEEN LOAD, SHEAR FORCE AND BENDING MOMENT**

Fig. 6.45 shows a beam carrying a uniformly distributed load of  $w$  per unit length. Consider the equilibrium of the portion of the beam between sections 1-1 and 2-2. This portion is at a distance of  $x$  from left support and is of length  $dx$ .

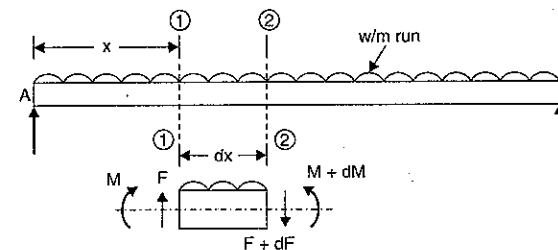

Fig. 6.45

Let

- $F$  = Shear force at the section 1-1,  
 $F + dF$  = Shear force at the section 2-2,  
 $M$  = Bending moment at the section 1-1,  
 $M + dM$  = Bending moment at the section 2-2.

The forces and moments acting on the length ' $dx$ ' of the beam are :

- (i) The force  $F$  acting vertically up at the section 1-1.
- (ii) The force  $F + dF$  acting vertically downwards at the section 2-2.
- (iii) The load  $w \times dx$  acting downwards.
- (iv) The moments  $M$  and  $(M + dM)$  acting at section 1-1 and section 2-2 respectively.

The portion of the beam of length  $dx$  is in equilibrium. Hence resolving the forces acting on this part vertically, we get

$$F - w \cdot dx - (F + dF) = 0$$

$$\text{or} \quad -dF = w \cdot dx \quad \text{or} \quad \frac{dF}{dx} = -w.$$

The above equation shows that the rate of change of shear force is equal to the rate of loading.

Taking the moments of the forces and couples about the section 2-2, we get

$$M - w \cdot dx \cdot \frac{dx}{2} + F \cdot dx = M + dM$$

$$\text{or} \quad -\frac{w(dx)^2}{2} + F \cdot dx = dM$$

Neglecting the higher powers of small quantities, we get

$$F \cdot dx = dM$$

$$\text{or} \quad F = \frac{dM}{dx} \quad \text{or} \quad \frac{dM}{dx} = F.$$

The above equation shows that the rate of change of bending moment is equal to the shear force at the section.

### HIGHLIGHTS

1. Shear force at a section is the resultant vertical force to the right or left of the section.
2. The diagram which shows the variation of the shear force along the length of a beam, is known as shear force diagram.
3. Bending moment at a section is algebraic sum of the moments of all the forces acting to the left or right of the section.
4. The diagram which shows the variation of the bending moment along the length of a beam, is known as bending moment diagram.
5. A beam which is fixed at one end and free at the other is known as cantilever beam. But a beam supported or resting freely on the supports at its both ends, is known as simply supported beam.
6. If the end portion of a beam is extended beyond the support, such beam is known as overhanging beam.
7. A load acting at a point, is known as concentrated load or a point load.
8. If a left portion of a section is considered, then S.F. will be positive at the section if the resultant of the vertical forces (including reactions) to the left of the section is upwards. But if the resultant is acting downwards then S.F. at the section will be negative.
9. If a right portion of a section is considered, the S.F. will be positive at the section if the resultant of the vertical forces to the right of the section is downwards. But if the resultant is acting upwards then S.F. at the section will be negative.
10. If a left portion of a section is considered, the B.M. will be positive at the section if the moment of all vertical forces and of reaction, at the section is clockwise. But if the resultant moment at the section is anti-clockwise, then B.M. will be negative.
11. If a right portion of a section is considered, the B.M. will be positive at the section if the resultant moment at the section is anti-clockwise. But if the resultant moment at the section is clockwise, then B.M. will be positive.
12. The shear force changes suddenly at a section where there is a vertical point load.

13. The shear force between any two vertical loads remains constant.
14. Shear force for a uniformly distributed load varies according to a straight line law whereas B.M. varies according to a parabolic curve.
15. B.M. is maximum at a section where S.F. is zero after changing its sign.
16. The point where B.M. is zero after changing its sign, is known as point of contraflexure or point of inflexion.
17. When an inclined load is acting on a beam, then inclined load is resolved into two components. Vertical component will cause S.F. and B.M. whereas horizontal component will cause axial thrust in the beam.
18. When a beam is subjected to a couple at a section, then B.M. changes suddenly at the section but S.F. remains unaltered at the section.

### EXERCISE 6

#### (A) Theoretical Questions

1. Define and explain the following terms :  
Shear force, bending moment, shear force diagram and bending moment diagram.
2. What are the different types of beams ? Differentiate between a cantilever and a simply supported beam.
3. What are the different types of loads acting on a beam ? Differentiate between a point load and a uniformly distributed load.
4. What are the sign conventions for shear force and bending moment in general ?
5. Draw the S.F. and B.M. diagrams for a cantilever of length  $L$  carrying a point load  $W$  at the free end.
6. Draw the S.F. and B.M. diagrams for a cantilever of length  $L$  carrying a uniformly distributed load of  $w$  per m length over its entire length.
7. Draw the S.F. and B.M. diagrams for a cantilever of length  $L$  carrying a gradually varying load from zero at the free end to  $w$  per unit length at the fixed end.
8. Draw the S.F. and B.M. diagrams for a simply supported beam of length  $L$  carrying a point load  $W$  at its middle point.
9. Draw the S.F. and B.M. diagrams for a simply supported beam carrying a uniformly distributed load of  $w$  per unit length over the entire span. Also calculate the maximum B.M.
10. Draw the S.F. and B.M. diagrams for a simply supported beam carrying a uniformly varying load from zero at each end to  $w$  per unit length at the centre.
11. What do you mean by point of contraflexure ? Is the point of contraflexure and point of inflexion different ?
12. How many points of contraflexure you will have for simply supported beam overhanging at one end only ?
13. How will you draw the S.F. and B.M. diagrams for a beam which is subjected to inclined loads ?
14. What do you mean by thrust diagram ?
15. Draw the S.F. and B.M. diagrams for a simply supported beam of length  $L$  which is subjected to a clockwise couple  $\mu$  at the centre of the beam.

#### (B) Numerical Problems

1. A cantilever beam of length 2 m carries a point load of 1 kN at its free end, and another load of 2 kN at a distance of 1 m from the free end. Draw the S.F. and B.M. diagrams for the cantilever.

$$[\text{Ans. } F_{\max} = +3 \text{ kN} ; M_{\max} = -4 \text{ kNm}]$$



2. A cantilever beam of length 4 m carries point loads of 1 kN, 2 kN and 3 kN at 1, 2 and 4 m from the fixed end. Draw the shear force and B.M. diagrams for the cantilever.  
[Ans.  $F_{max} = +6$  kN;  $M_{max} = -17$  kNm]
3. A cantilever of length 2 m carries a uniformly distributed load of 3 kN/m run over a length of 1 m from the fixed end. Draw the S.F. and B.M. diagrams. [Ans.  $F_{max} = +3$  kN;  $M_{max} = -1.5$  kNm]
4. A cantilever of length 5 m carries a uniformly distributed load of 2 kN/m length over the whole length and a point load of 4 kN at the free end. Draw the S.F. and B.M. diagrams for the cantilever.  
[Ans.  $F_{max} = +14$  kN;  $M_{max} = -45$  kNm]
5. A cantilever of length 4 m carries a uniformly distributed load of 1 kN/m run over the whole length and a point load of 2 kN at a distance of 1 m from the free end. Draw the S.F. and B.M. diagrams for the cantilever.  
[Ans.  $F_{max} = +14$  kN;  $M_{max} = -14$  kNm]
6. A cantilever 2 m long is loaded with a uniformly distributed load of 2 kN/m run over a length of 1 m from the free end. It also carries a point load of 4 kN at a distance of 0.5 m from the free end. Draw the shear force and B.M. diagrams.  
[Ans.  $F_{max} = +6$  kN;  $M_{max} = -9$  kNm]
7. A cantilever of length 6 m carries two point loads of 2 kN and 3 kN at a distance of 1 m and 6 m from the fixed end respectively. In addition to this the beam also carries a uniformly distributed load of 1 kN/m over a length of 2 m at a distance of 3 m from the fixed end. Draw the S.F. and B.M. diagrams.  
[Ans.  $F_{max} = +7$  kN;  $M_{max} = -28$  kNm]
8. A cantilever of length 6 m carries a gradually varying load, zero at the free end to 2 kN/m at the fixed end. Draw the S.F. and B.M. diagrams for the cantilever.  
[Ans.  $F_{max} = +6$  kN;  $M_{max} = -12$  kNm]
9. A simply supported beam of length 8 m carries point loads of 4 kN and 6 kN at a distance of 2 m and 4 m from the left end. Draw the S.F. and B.M. diagrams for the beam.  
[Ans.  $M_{max} = +20$  kNm]
10. A simply supported beam of length 10 m carries point loads of 30 kN and 50 kN at a distance of 3 m and 7 m from the left end. Draw the S.F. and B.M. diagrams for the beam.  
[Ans.  $M_{max} = +132$  kNm]
11. A simply supported beam of length 8 m carries point loads of 4 kN, 10 kN and 7 kN at a distance of 1.5 m, 2.5 m and 2 m respectively from left end A. Draw the S.F. and B.M. diagrams for the simply supported beam.  
[Ans.  $M_{max} = +90$  kNm]
12. A simply supported beam is carrying a uniformly distributed load of 2 kN/m over a length of 3 m from the right end. The length of the beam is 6 m. Draw the S.F. and B.M. diagrams for the beam and also calculate the maximum B.M. on the section.  
[Ans.  $M_{max} = +5.06$  kNm]
13. A beam of length 6 m is simply supported at the ends and carries a uniformly distributed load of 1.5 kN/m run and three concentrated loads of 1 kN, 2 kN and 3 kN acting at a distance of 1.5 m, 3 m and 4.5 m respectively from left end. Draw the S.F. and B.M. diagrams and determine the maximum bending moment.  
[Ans. 12.75 kNm]
14. A beam of length 10 m is simply supported and carries point loads of 5 kN each at a distance of 3 m and 7 m from left support and also a uniformly distributed load of 1 kN/m between the point loads. Draw S.F. and B.M. diagrams for the beam.  
[Ans.  $M_{max} = +23$  kNm]
15. A beam of length 6 m is simply supported at its ends. It is loaded with a gradually varying load of 750 N/m from left hand support to 1500 N/m to the right hand support. Construct the S.F. and B.M. diagrams and find the amount and position of the maximum B.M. over the beam.  
[Ans.  $M_{max} = 5077.5$  Nm at 3.165 m from left hand support]
16. A simply supported beam of length 8 m rests on supports 6 m apart, the right hand end is overhanging by 2 m. The beam carries a uniformly distributed load of 1500 N/m over the entire length. Draw S.F. and B.M. diagrams and find the point of contraflexure, if any.  
[Ans.  $M_{max} = 5.33$  kNm; 5.33 from left hand support]

17. A simply supported beam of length 8 m rests on supports 5 m apart, the right hand end is overhanging by 2 m and the left hand end is overhanging by 1 m. The beam carries a uniformly distributed load of 5 kN/m over the entire length. It also carries two point loads of 4 kN and 6 kN at each end of the beam. The load of 4 kN is at the extreme left of the beams, whereas the load of 6 kN is at the extreme right of the beam. Draw S.F. and B.M. diagrams for the beam and find the points of contraflexure.  
[Ans. 1.405 m and 4.955 from the extreme left of the beam]
18. A beam is loaded as shown in Fig. 6.46. Draw the S.F. and B.M. diagrams and find :  
(i) maximum S.F.  
(ii) maximum B.M.  
(iii) point of inflexion.

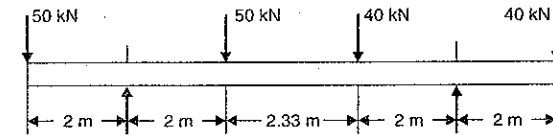

Fig. 6.46

- [Ans. 50 kN; 100 kN; none]
19. A beam is loaded as shown in Fig. 6.47. Find the reactions at A and B. Also draw the S.F., B.M. and thrust diagrams.

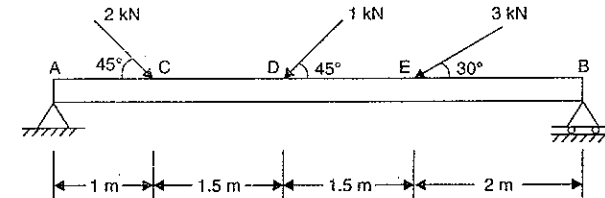

Fig. 6.47

- [Ans.  $R_A = 2.09$  kN;  $R_B = 1.53$  kN;  $H_A = -1.893$  kN]
20. A simply supported beam of length 5 m, carries a uniformly distributed load of 100 N/m extending from the left end to a point 2 m away. There is also a clockwise couple of 1500 Nm applied at the centre of the beam. Draw the S.F. and B.M. diagrams for the beam and find the maximum bending moment.  
[Ans. 845 Nm at a distance of 1.3 m from left end]

# 7

## Bending Stresses in Beams

### 7.1. INTRODUCTION

When some external load acts on a beam, the shear force and bending moments are set up at all sections of the beam. Due to the shear force and bending moment, the beam undergoes certain deformation. The material of the beam will offer resistance or stresses against these deformations. These stresses with certain assumptions can be calculated. The stresses introduced by bending moment are known as *bending stresses*. In this chapter, the theory of pure bending, expression for bending stresses, bending stress in symmetrical and unsymmetrical sections, strength of a beam and composite beams will be discussed.

### 7.2. PURE BENDING OR SIMPLE BENDING

If a length of a beam is subjected to a constant bending moment and no shear force (*i.e.*, zero shear force), then the stresses will be set up in that length of the beam due to B.M. only and that length of the beam is said to be in *pure bending* or simple bending. The stresses set up in that length of beam are known as bending stresses.

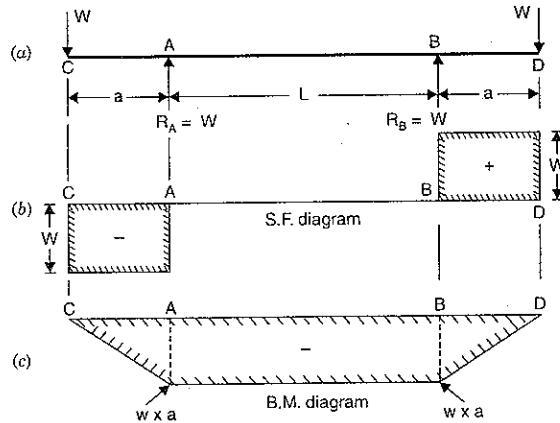

Fig. 7.1

A beam simply supported at A and B and overhanging by same length at each support is shown in Fig. 7.1. A point load W is applied at each end of the overhanging portion. The

S.F. and B.M. for the beam are drawn as shown in Fig. 7.1 (b) and Fig. 7.1 (c) respectively. From these diagrams, it is clear that there is no shear force between A and B but the B.M. between A and B is constant.

This means that between A and B, the beam is subjected to a constant bending moment only. This condition of the beam between A and B is known as pure bending or simple bending.

### 7.3. THEORY OF SIMPLE BENDING WITH ASSUMPTIONS MADE

Before discussing the theory of simple bending, let us see the assumptions made in the theory of simple bending. The following are the important assumptions :

1. The material of the beam is homogeneous\* and isotropic\*\*.
2. The value of Young's modulus of elasticity is the same in tension and compression.
3. The transverse sections which were plane before bending, remain plane after bending also.
4. The beam is initially straight and all longitudinal filaments bend into circular arcs with a common centre of curvature.
5. The radius of curvature is large compared with the dimensions of the cross-section.
6. Each layer of the beam is free to expand or contract, independently of the layer, above or below it.

#### Theory of Simple Bending

Fig. 7.2 (a) shows a part of a beam subjected to simple bending. Consider a small length  $\delta x$  of this part of beam. Consider two sections AB and CD which are normal to the axis of the beam N-N. Due to the action of the bending moment, the part of length  $\delta x$  will be deformed as shown in Fig. 7.2 (b). From this figure, it is clear that all the layers of the beam, which were originally of the same length, do not remain of the same length any more.

The top layer such as AC has deformed to the shape A'C'. This layer has been shortened in its length. The bottom layer BD has deformed to the shape B'D'. This layer has been elongated. From the Fig. 7.2 (b), it is clear that some of the layers have been shortened while some of them are elongated. At a level between the top and bottom of the beam, there will be a layer which is neither shortened nor elongated. This layer is known as *neutral layer* or *neutral*

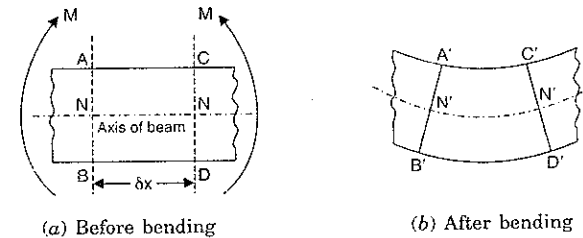

Fig. 7.2

\*Homogeneous means the material is of the same kind throughout.

\*\* Isotropic means that the elastic properties in all directions are equal.

surface. This layer in Fig. 7.2 (b) is shown by  $N' - N'$  and in Fig. 7.2 (a) by  $N - N$ . The line of intersection of the neutral layer on a cross-section of a beam is known as *neutral axis* (written as N.A.).

The layers above  $N - N$  (or  $N' - N'$ ) have been shortened and those below, have been elongated. Due to the decrease in lengths of the layers above  $N - N$ , these layers will be subjected to compressive stresses. Due to the increase in the lengths of layers below  $N - N$ , these layers will be subjected to tensile stresses.

We also see that the top layer has been shortened maximum. As we proceed towards the layer  $N - N$ , the decrease in length of the layers decreases. At the layer  $N - N$ , there is no change in length. This means the compressive stress will be maximum at the top layer. Similarly the increase in length will be maximum at the bottom layer. As we proceed from bottom layer towards the layer  $N - N$ , the increase in length of layers decreases. Hence the amount by which a layer increases or decreases in length, depends upon the position of the layer with respect to  $N - N$ . This theory of bending is known as theory of simple bending.

**7.4. EXPRESSION FOR BENDING STRESS**

Fig. 7.3 (a) shows a small length  $\delta x$  of a beam subjected to a simple bending. Due to the action of bending, the part of length  $\delta x$  will be deformed as shown in Fig. 7.3 (b). Let  $A'B'$  and  $C'D'$  meet at  $O$ .

Let  $R$  = Radius of neutral layer  $N'N'$

$\theta$  = Angle subtended at  $O$  by  $A'B'$  and  $C'D'$  produced.

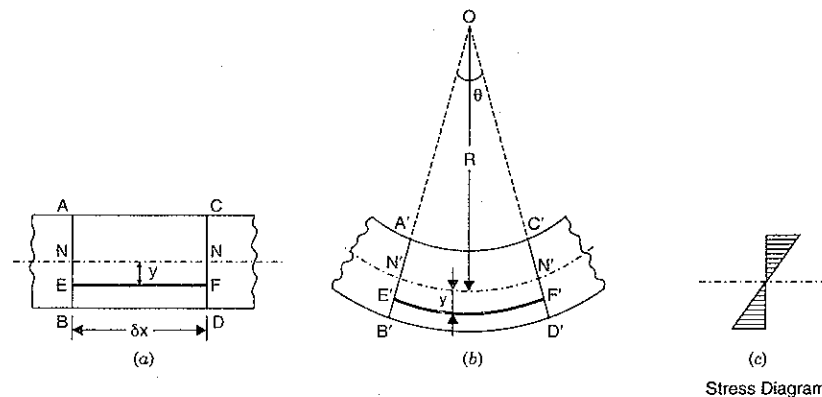

Fig. 7.3

**7.4.1. Strain Variation Along the Depth of Beam.** Consider a layer  $EF$  at a distance  $y$  below the neutral layer  $NN$ . After bending this layer will be elongated to  $E'F'$ .

Original length of layer  $EF = \delta x$ .

Also length of neutral layer  $NN = \delta x$ .

After bending, the length of neutral layer  $N'N'$  will remain unchanged. But length of layer  $E'F'$  will increase. Hence

$$N'N' = NN = \delta x.$$

Now from Fig. 7.3 (b),

$$N'N' = R \times \theta$$

and

$$E'F' = (R + y) \times \theta \quad (\because \text{Radius of } E'F' = R + y)$$

But

$$N'N' = NN = \delta x.$$

Hence

$$\delta x = R \times \theta$$

$\therefore$  Increase in the length of the layer  $EF$

$$= E'F' - EF = (R + y) \theta - R \times \theta \quad (\because EF = \delta x = R \times \theta)$$

$$= y \times \theta$$

$\therefore$  Strain in the layer  $EF$

$$= \frac{\text{Increase in length}}{\text{Original length}}$$

$$= \frac{y \times \theta}{EF} = \frac{y \times \theta}{R \times \theta} \quad (\because EF = \delta x = R \times \theta)$$

$$= \frac{y}{R}$$

As  $R$  is constant, hence the strain in a layer is proportional to its distance from the neutral axis. The above equation shows the variation of strain along the depth of the beam. The variation of strain is linear.

**7.4.2. Stress Variation**

Let

$\sigma$  = Stress in the layer  $EF$   
 $E$  = Young's modulus of the beam

Then

$$E = \frac{\text{Stress in the layer } EF}{\text{Strain in the layer } EF}$$

$$= \frac{\sigma}{\left(\frac{y}{R}\right)} \quad (\because \text{Strain in } EF = \frac{y}{R})$$

$$\therefore \sigma = E \times \frac{y}{R} = \frac{E}{R} \times y \quad \dots(7.1)$$

Since  $E$  and  $R$  are constant, therefore stress in any layer is directly proportional to the distance of the layer from the neutral layer. The equation (7.1) shows the variation of stress along the depth of the beam. The variation of stress is linear.

In the above case, all layers below the neutral layer are subjected to tensile stresses whereas the layers above neutral layer are subjected to compressive stresses. The Fig. 7.3 (c) shows the stress distribution.

The equation (7.1) can also be written as

$$\frac{\sigma}{y} = \frac{E}{R} \quad \dots(7.2)$$

**7.5. NEUTRAL AXIS AND MOMENT OF RESISTANCE**

The neutral axis of any transverse section of a beam is defined as the line of intersection of the neutral layer with the transverse section. It is written as N.A.

In Art. 7.4, we have seen that if a section of a beam is subjected to pure sagging moment, then the stresses will be compressive at any point above the neutral axis and tensile below the

neutral axis. There is no stress at the neutral axis. The stress at a distance  $y$  from the neutral axis is given by equation (7.1) as

$$\sigma = \frac{E}{R} \times y.$$

Fig. 7.4 shows the cross-section of a beam. Let N.A. be the neutral axis of the section. Consider a small layer at a distance  $y$  from the neutral axis. Let  $dA$  = Area of the layer.

Now the force on the layer

$$= \text{Stress on layer} \times \text{Area of layer}$$

$$= \sigma \times dA$$

$$= \frac{E}{R} \times y \times dA$$

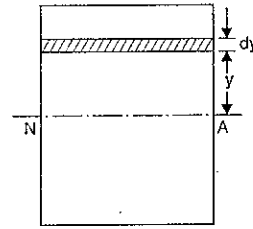

Fig. 7.4

$$\therefore (i) \left( \because \sigma = \frac{E}{R} \times y \right)$$

Total force on the beam section is obtained by integrating the above equation.

$\therefore$  Total force on the beam section

$$= \int \frac{E}{R} \times y \times dA$$

$$= \frac{E}{R} \int y \times dA$$

( $\because E$  and  $R$  is constant)

But for pure bending, there is no force on the section of the beam (or force is zero).

$$\therefore \frac{E}{R} \int y \times dA = 0$$

$$\text{or} \quad \int y \times dA = 0 \quad \left( \text{as } \frac{E}{R} \text{ cannot be zero} \right)$$

Now  $y \times dA$  represents the moment of area  $dA$  about neutral axis. Hence  $\int y \times dA$  represents the moment of entire area of the section about neutral axis. But we know that moment of any area about an axis passing through its centroid, is also equal to zero. Hence neutral axis coincides with the centroidal axis. Thus the centroidal axis of a section gives the position of neutral axis.

**7.5.1. Moment of Resistance.** Due to pure bending, the layers above the N.A. are subjected to compressive stresses whereas the layers below the N.A. are subjected to tensile stresses. Due to these stresses, the forces will be acting on the layers. These forces will have moment about the N.A. The total moment of these forces about the N.A. for a section is known as moment of resistance of that section.

The force on the layer at a distance  $y$  from neutral axis in Fig. 7.4 is given by equation (i), as

$$\text{Force on layer} = \frac{E}{R} \times y \times dA$$

Moment of this force about N.A.

$$= \text{Force on layer} \times y$$

$$= \frac{E}{R} \times y \times dA \times y$$

$$= \frac{E}{R} \times y^2 \times dA$$

Total moment of the forces on the section of the beam (or moment of resistance)

$$= \int \frac{E}{R} \times y^2 \times dA = \frac{E}{R} \int y^2 \times dA$$

Let  $M$  = External moment applied on the beam section. For equilibrium the moment of resistance offered by the section should be equal to the external bending moment.

$$\therefore M = \frac{E}{R} \int y^2 \times dA.$$

But the expression  $\int y^2 \times dA$  represents the moment of inertia of the area of the section about the neutral axis. Let this moment of inertia be  $I$ .

$$\therefore M = \frac{E}{R} \times I \quad \text{or} \quad \frac{M}{I} = \frac{E}{R} \quad \dots(7.3)$$

But from equation (7.2), we have

$$\frac{\sigma}{y} = \frac{E}{R}$$

$$\therefore \frac{M}{I} = \frac{\sigma}{y} = \frac{E}{R} \quad \dots(7.4)$$

The equation (7.4) is known as bending equation.

In equation (7.4), the different quantities are expressed in consistent units as given below :

$M$  is expressed in N mm ;  $I$  in  $\text{mm}^4$

$\sigma$  is expressed in  $\text{N/mm}^2$  ;  $y$  in mm

and  $E$  is expressed in  $\text{N/mm}^2$  ;  $R$  in mm.

**7.5.2. Condition of Simple Bending.** The equation (7.4) is applicable to a member which is subjected to a constant bending moment and the member is absolutely free from shear force. But in actual practice, a member is subjected to such loading that the B.M. varies from section to section and also the shear force is not zero. But shear force is zero at a section where bending moment is maximum. Hence the condition of simple bending may be assumed to be satisfied at such a section. Hence the stresses produced due to maximum bending moment, are obtained from equation (7.4) as the shear forces at these sections are generally zero. Hence the theory and equations discussed in the above articles are quite sufficient and give results which enables the engineers to design beams and structures and calculate their stresses and strains with a reasonable degree of approximation where B.M. is maximum.

## 7.6. BENDING STRESSES IN SYMMETRICAL SECTIONS

The neutral axis (N.A.) of a symmetrical section (such as circular, rectangular or square) lies at a distance of  $d/2$  from the outermost layer of the section where  $d$  is the diameter (for a circular section) or depth (for a rectangular or a square section). There is no stress at the neutral axis. But the stress at a point is directly proportional to its distance from the neutral axis. The maximum stress takes place at the outermost layer. For a simply supported beam, there is a compressive stress above the neutral axis and a tensile stress below it. If we plot these stresses, we will get a figure as shown in Fig. 7.5.

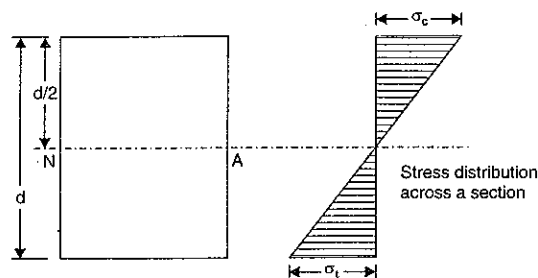

Fig. 7.5

**Problem 7.1.** A steel plate of width 120 mm and of thickness 20 mm is bent into a circular arc of radius 10 m. Determine the maximum stress induced and the bending moment which will produce the maximum stress. Take  $E = 2 \times 10^5 \text{ N/mm}^2$ .

**Sol. Given :**

Width of plate,  $b = 120 \text{ mm}$

Thickness of plate,  $t = 20 \text{ mm}$

$\therefore$  Moment of inertia,  $I = \frac{bt^3}{12} = \frac{120 \times 20^3}{12} = 8 \times 10^4 \text{ mm}^4$

Radius of curvature,  $R = 10 \text{ m} = 10 \times 10^3 \text{ mm}$

Young's modulus,  $E = 2 \times 10^5 \text{ N/mm}^2$

Let  $\sigma_{max}$  = Maximum stress induced, and  
 $M$  = Bending moment.

Using equation (7.2),  $\frac{\sigma}{y} = \frac{E}{R}$

$\therefore \sigma = \frac{E}{R} \times y \quad \dots(i)$

Equation (i) gives the stress at a distance  $y$  from N.A.

Stress will be maximum, when  $y$  is maximum. But  $y$  will be maximum at the top layer or bottom layer.

$\therefore y_{max} = \frac{t}{2} = \frac{20}{2} = 10 \text{ mm.}$

Now equation (i) can be written as

$$\begin{aligned} \sigma_{max} &= \frac{E}{R} \times y_{max} \\ &= \frac{2 \times 10^5}{10 \times 10^3} \times 10 = 200 \text{ N/mm}^2. \text{ Ans.} \end{aligned}$$

From equation (7.4), we have

$$\frac{M}{I} = \frac{E}{R}$$

$$\begin{aligned} \therefore M &= \frac{E}{R} \times I = \frac{2 \times 10^5}{10 \times 10^3} \times 8 \times 10^4 \\ &= 16 \times 10^5 \text{ N mm} = 1.6 \text{ kNm. Ans.} \end{aligned}$$

**Problem 7.2.** Calculate the maximum stress\* induced in a cast iron pipe of external diameter 40 mm, of internal diameter 20 mm and of length 4 metre when the pipe is supported at its ends and carries a point load of 80 N at its centre.

**Sol. Given :**

External dia.,  $D = 40 \text{ mm}$

Internal dia.,  $d = 20 \text{ mm}$

Length,  $L = 4 \text{ m} = 4 \times 1000 = 4000 \text{ mm}$

Point load,  $W = 80 \text{ N}$

In case of simply supported beam carrying a point load at the centre, the maximum bending moment is at the centre of the beam.

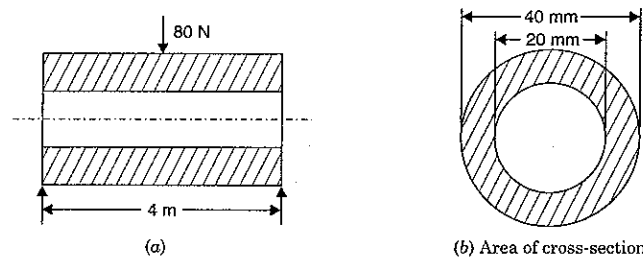

Fig. 7.6

And maximum B.M.  $= \frac{W \times L}{4}$

$\therefore$  Maximum B.M.  $= \frac{80 \times 4000}{4} = 8 \times 10^4 \text{ Nmm}$

$\therefore M = 8 \times 10^4 \text{ Nmm}$

Fig. 7.6 (b) shows the cross-section of the pipe.

Moment of inertia of hollow pipe,

$$\begin{aligned} I &= \frac{\pi}{64} [D^4 - d^4] \\ &= \frac{\pi}{64} [40^4 - 20^4] = \frac{\pi}{64} [2560000 - 160000] \\ &= 117809.7 \text{ mm}^4 \end{aligned}$$

Now using equation (7.4),

$$\frac{M}{I} = \frac{\sigma}{y} \quad \dots(i)$$

when  $y$  is maximum, stress will be maximum. But  $y$  is maximum at the top layer from the N.A.

$$\therefore y_{max} = \frac{D}{2} = \frac{40}{2} = 20 \text{ mm}$$

\*The bending stress will be maximum at the section where B.M. is maximum. This is because

$$\frac{M}{I} = \frac{\sigma}{y} \text{ or } \sigma = \frac{M}{I} \times y.$$

The above equation (i) can be written as

$$\frac{M}{I} = \frac{\sigma_{max}}{y_{max}}$$

$$\begin{aligned} \therefore \sigma_{max} &= \frac{M}{I} \times y_{max} \\ &= \frac{8 \times 10^4 \times 20}{117809.7} = 13.58 \text{ N/mm}^2. \text{ Ans.} \end{aligned}$$

### 7.7. SECTION MODULUS

Section modulus is defined as the ratio of moment of inertia of a section about the neutral axis to the distance of the outermost layer from the neutral axis. It is denoted by the symbol  $Z$ . Hence mathematically section modulus is given by,

$$Z = \frac{I}{y_{max}} \quad \dots(7.5)$$

where  $I$  = M.O.I. about neutral axis

and  $y_{max}$  = Distance of the outermost layer from the neutral axis.

From equation (7.4), we have

$$\frac{M}{I} = \frac{\sigma}{y}$$

The stress  $\sigma$  will be maximum, when  $y$  is maximum. Hence above equation can be written as

$$\frac{M}{I} = \frac{\sigma_{max}}{y_{max}}$$

$$\therefore M = \sigma_{max} \cdot \frac{I}{y_{max}}$$

$$\text{But } \frac{I}{y_{max}} = Z$$

$$\therefore M = \sigma_{max} \cdot Z \quad \dots(7.6)$$

In the above equation,  $M$  is the maximum bending moment (or moment of resistance offered by the section). Hence moment of resistance offered the section is maximum when section modulus  $Z$  is maximum. Hence section modulus represent the strength of the section.

### 7.8. SECTION MODULUS FOR VARIOUS SHAPES OR BEAM SECTIONS

#### 1. Rectangular Section

Moment of inertia of a rectangular section about an axis through its C.G. (or through N.A.) is given by,

$$I = \frac{bd^3}{12}$$

Distance of outermost layer from N.A. is given by,

$$y_{max} = \frac{d}{2}$$

$\therefore$  Section modulus is given by,

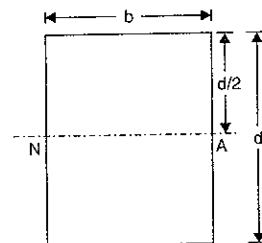

Fig. 7.7

$$Z = \frac{I}{y_{max}} = \frac{bd^3}{12 \times \left(\frac{d}{2}\right)} = \frac{bd^3}{12} \times \frac{2}{d} = \frac{bd^2}{6} \quad \dots(7.7)$$

#### 2. Hollow Rectangular Section

$$\begin{aligned} \text{Here } I &= \frac{BD^3}{12} - \frac{bd^3}{12} \\ &= \frac{1}{12} [BD^3 - bd^3] \\ y_{max} &= \frac{D}{2} \\ \therefore Z &= \frac{I}{y_{max}} \\ &= \frac{\frac{1}{12} [BD^3 - bd^3]}{\left(\frac{D}{2}\right)} \end{aligned}$$

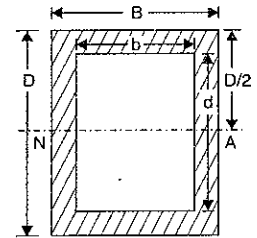

Fig. 7.8

$$= \frac{1}{6D} [BD^3 - bd^3] \quad \dots(7.8)$$

#### 3. Circular Section

For a circular section,

$$I = \frac{\pi}{64} d^4 \quad \text{and} \quad y_{max} = \frac{d}{2}$$

$$\therefore Z = \frac{I}{y_{max}} = \frac{\frac{\pi}{64} d^4}{\left(\frac{d}{2}\right)} = \frac{\pi}{32} d^3 \quad \dots(7.9)$$

#### 4. Hollow Circular Section

$$\text{Here } I = \frac{\pi}{64} [D^4 - d^4]$$

and

$$y_{max} = \frac{D}{2}$$

$$\begin{aligned} \therefore Z &= \frac{I}{y_{max}} = \frac{\frac{\pi}{64} [D^4 - d^4]}{\left(\frac{D}{2}\right)} \\ &= \frac{\pi}{32D} [D^4 - d^4] \quad \dots(7.10) \end{aligned}$$

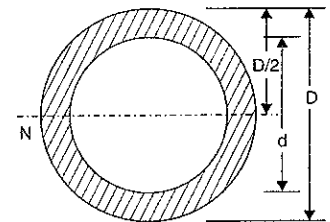

Fig. 7.9

**Problem 7.3.** A cantilever of length 2 metre fails when a load of 2 kN is applied at the free end. If the section of the beam is 40 mm  $\times$  60 mm, find the stress at the failure.

**Sol.** Given :

Length,  $L = 2 \text{ m} = 2 \times 10^3 \text{ mm}$

Load,  $W = 2 \text{ kN} = 2000 \text{ N}$

Section of beam is 40 mm × 60 mm.

∴ Width of beam,  $b = 40$  mm

Depth of beam,  $d = 60$  mm

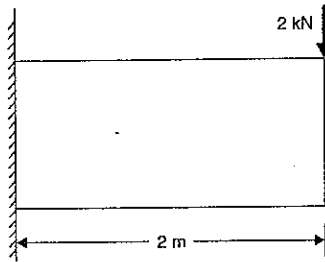

Fig. 7.10

Fig. 7.10 (a) shows the section of the beam.

Section modulus of a rectangular section is given by equation (7.7).

$$\therefore Z = \frac{bd^2}{6} = \frac{40 \times 60^2}{6} = 24000 \text{ mm}^3$$

Maximum bending moment for a cantilever shown in Fig. 7.10 is at the fixed end.

$$\therefore M = W \times L = 2000 \times 2 \times 10^3 = 4 \times 10^6 \text{ Nmm}$$

Let  $\sigma_{max}$  = Stress at the failure

Using equation (7.6), we get

$$M = \sigma_{max} \cdot Z$$

$$\therefore \sigma_{max} = \frac{M}{Z} = \frac{4 \times 10^6}{24000} = 166.67 \text{ N/mm}^2. \text{ Ans.}$$

**Problem 7.4.** A rectangular beam 200 mm deep and 300 mm wide is simply supported over a span of 8 m. What uniformly distributed load per metre the beam may carry, if the bending stress is not to exceed 120 N/mm<sup>2</sup>.

**Sol.** Given :

Depth of beam,  $d = 200$  mm

Width of beam,  $b = 300$  mm

Length of beam,  $L = 8$  m

Max. bending stress,

$$\sigma_{max} = 120 \text{ N/mm}^2$$

Let  $w$  = Uniformly distributed load per m length over the beam

(Fig. 7.11 (a) shows the section of the beam).

Section modulus for a rectangular section is given by equation (7.7).

$$\therefore Z = \frac{bd^2}{6} = \frac{300 \times 200^2}{6} = 2000000 \text{ mm}^3$$

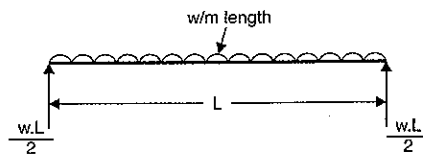

Fig. 7.11

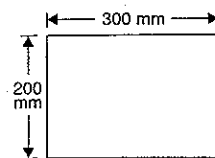

Fig. 7.11 (a)

Max. B.M. for a simply supported beam carrying uniformly distributed load as shown in Fig. 7.11 is at the centre of the beam. It is given by

$$M = \frac{w \times L^2}{8} = \frac{w \times 8^2}{8} \quad (\because L = 8 \text{ m})$$

$$= 8w \text{ Nm} = 8w \times 1000 \text{ Nmm}$$

$$= 8000w \text{ Nmm} \quad (\because 1 \text{ m} = 1000 \text{ mm})$$

Now using equation (7.6), we get

$$M = \sigma_{max} \cdot Z$$

$$\text{or } 8000w = 120 \times 2000000$$

$$\therefore w = \frac{120 \times 2000000}{8000} = 30 \times 1000 \text{ N/m} = 30 \text{ kN/m. Ans.}$$

**Problem 7.5.** A rectangular beam 300 mm deep is simply supported over a span of 4 metres. Determine the uniformly distributed load per metre which the beam may carry, if the bending stress should not exceed 120 N/mm<sup>2</sup>. Take  $I = 8 \times 10^6 \text{ mm}^4$ .

(Annamalai University, 1991)

**Sol.** Given :

Depth,  $d = 300$  mm

Span,  $L = 4$  m

Max. bending stress,  $\sigma_{max} = 120 \text{ N/mm}^2$

Moment of inertia,  $I = 8 \times 10^6 \text{ mm}^4$

Let,  $w$  = U.D.L. per metre length over the beam in N/m.

The bending stress will be maximum, where bending moment is maximum. For a simply supported beam carrying U.D.L., the bending moment is maximum at the centre of the beam [i.e., at point C of Fig. 7.11 (b)]

$$\therefore \text{Max. B.M.} = 2w \times 2 - 2w \times 1$$

$$= 4w - 2w$$

$$= 2w \text{ Nm}$$

$$= 2w \times 1000 \text{ Nmm}$$

$$\text{or } M = 2000w \text{ Nmm}$$

Now using equation (7.6), we get

$$M = \sigma_{max} \times Z$$

... (i)

$$\text{where } Z = \frac{I}{y_{max}} = \frac{8 \times 10^6}{150}$$

$$\left( \because y_{max} = \frac{d}{2} = \frac{300}{2} = 150 \text{ mm} \right)$$

Hence above equation (i) becomes as

$$2000w = 120 \times \frac{8 \times 10^6}{150}$$

$$\text{or } w = \frac{120 \times 8 \times 10^6}{2000 \times 150} = 3200 \text{ N/m. Ans.}$$

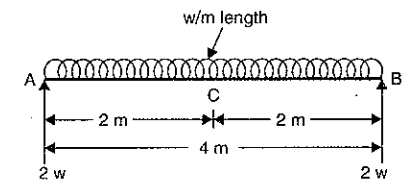

Fig. 7.11 (b)

**Problem 7.6.** A square beam 20 mm × 20 mm in section and 2 m long is supported at the ends. The beam fails when a point load of 400 N is applied at the centre of the beam. What uniformly distributed load per metre length will break a cantilever of the same material 40 mm wide, 60 mm deep and 3 m long?

**Sol.** Given :

Depth of beam,  $d = 20$  mm  
 Width of beam,  $b = 20$  mm  
 Length of beam,  $L = 2$  m  
 Point load,  $W = 400$  N

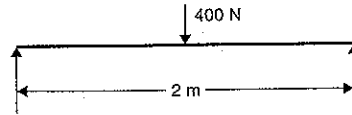

Fig. 7.12

In this problem, the maximum stress for the simply supported beam is to be calculated first. As the material of the cantilever is same as that of simply supported beam, hence maximum stress for the cantilever will also be same as that of simply supported beam.

Fig. 7.12 (a) shows the section of beam.

The section modulus for the rectangular section of simply supported beam is given by equation (7.7).

$$\therefore Z = \frac{bd^2}{6} = \frac{20 \times 20^2}{6} = \frac{4000}{3} \text{ mm}^3$$

Max. B.M. for a simply supported beam carrying a point load at the centre (as shown in Fig. 7.12) is given by,

$$M = \frac{w \times L}{4} = \frac{400 \times 2}{4} = 200 \text{ Nm}$$

$$= 200 \times 1000 = 200000 \text{ Nmm}$$

Let  $\sigma_{max}$  = Max. stress induced

Now using equation (7.6), we get

$$M = \sigma_{max} \cdot Z$$

$$\text{or } 200000 = \sigma_{max} \times \frac{4000}{3}$$

$$\therefore \sigma_{max} = \frac{200000 \times 3}{4000} = 150 \text{ N/mm}^2$$

Now let us consider the cantilever as shown in Fig. 7.13.

Let  $w$  = Uniformly distributed load per m run.

Maximum stress will be same as in case of simply supported beam.

$$\therefore \sigma_{max} = 150 \text{ N/mm}^2$$

Width of cantilever,  $b = 40$  mm

Depth of cantilever,  $d = 60$  mm

Length of cantilever,  $L = 3$  m

Fig. 7.13 (a) shows the section of cantilever beam.

Section modulus of rectangular section of cantilever =  $\frac{bd^2}{6}$

$$\therefore Z = \frac{40 \times 60^2}{6} = 24000 \text{ mm}^3$$

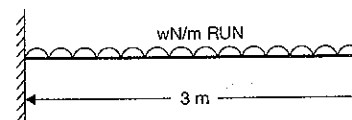

Fig. 7.13

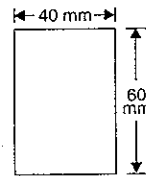

Fig. 7.13 (a)

Maximum B.M. for a cantilever

$$= \frac{wL^2}{2} = \frac{w \times 3^2}{2} = 4.5w \text{ Nm} = 4.5 \times 1000w \text{ Nmm}$$

$$\therefore M = 4.5 \times 1000w \text{ Nmm}$$

Now using equation (7.6), we get

$$M = \sigma_{max} \cdot Z$$

$$\text{or } 4.5 \times 1000w = 150 \times 24000$$

$$\therefore w = \frac{150 \times 24000}{4.5 \times 1000} = 800 \text{ N/m. Ans.}$$

**Problem 7.7.** A beam is simply supported and carries a uniformly distributed load of 40 kN/m run over the whole span. The section of the beam is rectangular having depth as 500 mm. If the maximum stress in the material of the beam is 120 N/mm<sup>2</sup> and moment of inertia of the section is  $7 \times 10^8$  mm<sup>4</sup>, find the span of the beam.

**Sol.** Given :

U.D.L.,  $w = 40$  kN/m =  $40 \times 1000$  N/m

Depth,  $d = 500$  mm

Max. stress,  $\sigma_{max} = 120$  N/mm<sup>2</sup>

M.O.I. of section,  $I = 7 \times 10^8$  mm<sup>4</sup>

Let  $L$  = Span of simply supported beam.

Section modulus of the section is given by equation (7.5), as

$$Z = \frac{I}{y_{max}}$$

$$\text{where } y_{max} = \frac{d}{2} = \frac{500}{2} = 250 \text{ mm}$$

$$\therefore Z = \frac{7 \times 10^8}{250} = 28 \times 10^5 \text{ mm}^3$$

The maximum B.M. for a simply supported beam, carrying a U.D.L. over the whole span is at the centre of the beam and is equal to  $\frac{w \cdot L^2}{8}$ .

$$\therefore M = \frac{w \cdot L^2}{8} = \frac{40000 \times L^2}{8}$$

$$= 5000L^2 \text{ Nm} = 5000L^2 \times 1000 \text{ Nmm}$$

Now using equation (7.6), we get

$$M = \sigma_{max} \cdot Z$$

$$\text{or } 5000 \times 1000 \times L^2 = 120 \times 28 \times 10^5$$

$$\text{or } L^2 = \frac{120 \times 28 \times 10^5}{5000 \times 1000} = 2.4 \times 28$$

$$\therefore L = \sqrt{2.4 \times 28} = 8.197 \text{ m say } 8.20 \text{ m. Ans.}$$

**Problem 7.8.** A timber beam of rectangular section is to support a load of 20 kN uniformly distributed over a span of 3.6 m when beam is simply supported. If the depth of section is to be twice the breadth, and the stress in the timber is not to exceed 7 N/mm<sup>2</sup>, find the dimensions of the cross-section.



How would you modify the cross-section of the beam, if it carries a concentrated load of 20 kN placed at the centre with the same ratio of breadth to depth?

**Sol. Given :**

Total load,  $W = 20 \text{ kN} = 20 \times 1000 \text{ N}$

Span,  $L = 3.6 \text{ m}$

Max. stress,  $\sigma_{\max} = 7 \text{ N/mm}^2$

Let  $b =$  Breadth of beam in mm

Then depth,  $d = 2b \text{ mm}$

Section modulus of rectangular beam  $= \frac{bd^2}{6}$

$$\therefore L = \frac{b \times (2b)^2}{6} = \frac{2b^3}{6} \text{ mm}^3$$

Maximum B.M., when the simply supported beam carries a U.D.L. over the entire span,

is at the centre of the beam and is equal to  $\frac{wL^2}{8}$  or  $\frac{WL}{8}$ .

$$\therefore M = \frac{WL}{8} = \frac{20000 \times 3.6}{8} = 9000 \text{ Nm}$$

$$= 9000 \times 1000 \text{ Nmm}$$

Now using equation (7.6), we get

$$M = \sigma_{\max} \cdot Z$$

$$\text{or } 9000 \times 1000 = 7 \times \frac{2b^3}{3}$$

$$\text{or } b^3 = \frac{3 \times 9000 \times 1000}{7 \times 2} = 1.92857 \times 10^6$$

$$\therefore b = (1.92857 \times 10^6)^{1/3}$$

$$= 124.47 \text{ mm say } 124.5 \text{ mm. Ans.}$$

$$\text{and } d = 2b = 2 \times 124.5 = 249 \text{ mm. Ans.}$$

Dimension of the section when the beam carries a point load at the centre.

B.M. is maximum at the centre and it is equal to  $\frac{W \times L}{4}$  when the beam carries a point load at the centre.

$$\therefore M = \frac{W \times L}{4} = \frac{20000 \times 3.6}{4} = 18000 \text{ Nm}$$

$$= 18000 \times 1000 \text{ Nmm}$$

$$\sigma_{\max} = 7 \text{ N/mm}^2$$

$$\text{and } Z = \frac{2b^3}{3} \quad (\because \text{In this case also } d = 2b)$$

Using equation (7.6), we get

$$M = \sigma_{\max} \cdot Z$$

$$\text{or } 18000 \times 1000 = 7 \times \frac{2b^3}{3}$$

$$\therefore b^3 = \frac{3 \times 18000 \times 1000}{7 \times 2} = 3.85714 \times 10^6$$

$$\therefore b = (3.85714 \times 10^6)^{1/3} = 156.82 \text{ mm. Ans.}$$

$$\text{and } d = 2 \times 156.82 = 313.64 \text{ mm. Ans.}$$

**Problem 7.9.** A timber beam of rectangular section of length 8 m is simply supported. The beam carries a U.D.L. of 12 kN/m run over the entire length and a point load of 10 kN at 3 metre from the left support. If the depth is two times the width and the stress in the timber is not to exceed 8 N/mm<sup>2</sup>, find the suitable dimensions of the section.

**Sol. Given :**

Length,  $L = 8 \text{ m}$

U.D.L.,  $w = 12 \text{ kN/m} = 12000 \text{ N/m}$

Point load,  $W = 10 \text{ kN} = 10000 \text{ N}$

Depth of beam  $= 2 \times$  Width of beam

$\therefore d = 2b$

Stress,  $\sigma_{\max} = 8 \text{ N/mm}^2$

First calculate the section where B.M. is maximum. Where B.M. is maximum, the shear force will be zero. Now the equations of pure bending can be used. For doing this, calculate the reactions  $R_A$  and  $R_B$  as shown in Fig. 7.14.

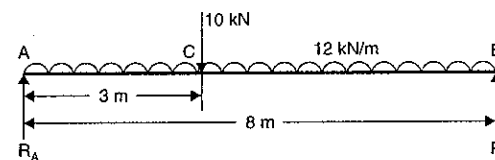

Fig. 7.14

Taking moments about A, we get

$$R_B \times 8 = 12000 \times 8 \times 4 + 10000 \times 3$$

$$\therefore R_B = \frac{12000 \times 32 + 30000}{8} = 51750 \text{ N}$$

$$\therefore R_A = \text{Total load} - R_B$$

$$= (12000 \times 8 + 10000) - 51750 = 54250 \text{ N}$$

Now S.F. at A  $= +R_A = +54250 \text{ N}$

S.F. just L.H.S. at C  $= 54250 - 12000 \times 3 = +18250 \text{ N}$

S.F. just R.H.S. of C  $= 18250 - 10000 = 8250 \text{ N}$

S.F. at B  $= -R_B = -51750 \text{ N}$

The S.F. is changing sign between section CB and hence at some section in C and B the S.F. will be zero.

Let S.F. is zero at  $x$  metre from B.

Equating the S.F. at this section to zero, we have

$$12000 \times x - R_B = 0$$

$$\text{or } 12000 \times x - 51750 = 0$$

$$\therefore x = \frac{51750}{12000} = 4.3125 \text{ m}$$

∴ Maximum B.M. will occur at 4.3125 m from B.

$$\begin{aligned} \therefore \text{Maximum B.M.} &= M = R_B \times 4.3125 - 12000 \times 4.3125 \times \frac{4.3125}{2} \\ &= 51750 \times 4.3125 - 111585.9375 \\ &= 111585.9375 \text{ Nm} = 111585.9375 \times 1000 \text{ Nmm} \end{aligned}$$

Section modulus for rectangular beam is given by,

$$Z = \frac{bd^2}{6} = \frac{b \times (2b)^2}{6} = \frac{2b^3}{3}$$

Now using equation (7.6), we get

$$M = \sigma_{max} \cdot Z$$

$$111585.9375 \times 1000 = 8 \times \frac{2b^3}{3}$$

$$\therefore b^3 = \frac{3 \times 111585.9375 \times 1000}{16} = 20.9223 \times 10^6$$

$$\therefore b = (20.9223 \times 10^6)^{1/3} = 275.5 \text{ mm. Ans.}$$

$$d = 2 \times 275.5 = 551 \text{ mm. Ans.}$$

**Problem 7.10.** A rolled steel joist of I section has the dimensions : as shown in Fig. 7.15.

This beam of I section carries a u.d.l. of 40 kN/m run on a span of 10 m, calculate the maximum stress produced due to bending.

Sol. Given :

u.d.l.,  $w = 40 \text{ kN/m} = 40000 \text{ N/m}$

Span,  $L = 10 \text{ m}$

Moment of inertia about the neutral axis

$$\begin{aligned} &= \frac{200 \times 400^3}{12} - \frac{(200 - 10) \times 360^3}{12} \\ &= 1066666666 - 738720000 \\ &= 327946666 \text{ mm}^4 \end{aligned}$$

Maximum B.M. is given by,

$$\begin{aligned} M &= \frac{w \times L^2}{8} = \frac{40000 \times 10^2}{8} \\ &= 500000 \text{ Nm} \\ &= 500000 \times 1000 \text{ Nmm} \\ &= 5 \times 10^8 \text{ Nmm} \end{aligned}$$

Now using the relation,

$$\frac{M}{I} = \frac{\sigma}{y}$$

$$\therefore \sigma = \frac{M}{I} \times y$$

$$\begin{aligned} \sigma_{max} &= \frac{M}{I} \times y_{max} = \frac{5 \times 10^8}{327946666} \times 200 \\ &= 304.92 \text{ N/mm}^2. \text{ Ans.} \end{aligned}$$

$$(\because y_{max} = 200 \text{ mm})$$

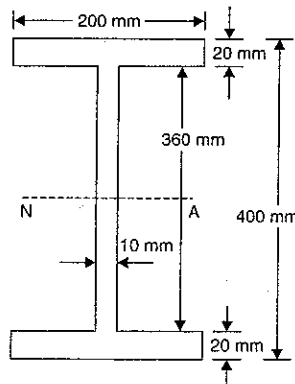

Fig. 7.15

**Problem 7.11.** An I-section shown in Fig. 7.16, is simply supported over a span of 12 m. If the maximum permissible bending stress is 80 N/mm<sup>2</sup>, what concentrated load can be carried at a distance of 4 m from one support?

Sol. Given :

Bending stress,  $\sigma_{max} = 80 \text{ N/mm}^2$

Let  $W =$  Concentrated load carried at a distance of 4 m from support B in Newton

To find the maximum bending moment (which will be at point C where concentrated load is acting), first calculate the reactions  $R_A$  and  $R_B$ .

Taking moments about point A, we get

$$R_B \times 12 = W \times 8$$

$$\therefore R_B = \frac{8W}{12} = \frac{2}{3}W$$

and

$$R_A = W - R_B = W - \frac{2}{3}W = \frac{W}{3}$$

B.M. at point C  $= R_A \times 8 = \frac{W}{3} \times 8 = \frac{8}{3}W \text{ Nm}$

But B.M. at C is maximum

∴ Maximum B.M.,

$$\begin{aligned} M_{max} &= \frac{8}{3}W \text{ Nm} = \frac{8}{3}W \times 1000 \text{ Nmm} \\ &= \frac{8000}{3}W \text{ Nmm} \end{aligned}$$

Now find the moment of inertia of the given I-section about the N.A.

$$\begin{aligned} \therefore I &= \frac{100 \times 225^3}{12} - \frac{(100 - 7.5) \times (225 - 2 \times 11.5)^3}{12} \\ &= 94921875 - \frac{92.5 \times (202)^3}{12} \\ &= 94921875 - 63535227.55 = 31386647.45 \text{ mm}^4 \end{aligned}$$

Now using the relation,

$$\frac{M}{I} = \frac{\sigma}{y}$$

or

$$\frac{M}{I} = \frac{\sigma_{max}}{y_{max}}$$

where  $y_{max} = \frac{225}{2} = 112.5 \text{ mm}$ .

Now substituting the known values, we get

$$\frac{\left(\frac{8000}{3}W\right)}{31386647.45} = \frac{80}{112.5}$$

or

$$W = \frac{80}{112.5} \times 31386647.45 \times \frac{3}{8000} = 8369.77 \text{ N. Ans.}$$

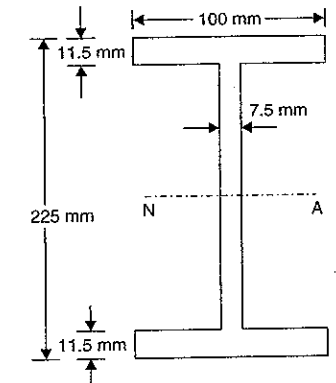

(a)

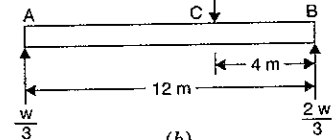

Fig. 7.16

**Problem 7.12.** Two circular beams where one is solid of diameter  $D$  and other is a hollow of outer dia.  $D_o$  and inner dia.  $D_i$ , are of the same length, same material and of same weight. Find the ratio of section modulus of these circular beams.

**Sol. Given :**

Dia. of solid beam =  $D$

Dias. of hollow beam =  $D_o$  and  $D_i$

Let  $L$  = Length of each beam (same length)

$W$  = Weight of each beam (same weight)

$\rho$  = Density of the material of each shaft (same material)

Now weight of solid beam =  $\rho \times g \times \text{Area of section} \times L$

$$= \rho \times g \times \frac{\pi}{4} D^2 \times L$$

Weight of hollow beam =  $\rho \times g \times \text{Area of section} \times L$

$$= \rho \times g \times \frac{\pi}{4} [D_o^2 - D_i^2] \times L$$

But the weights are same

$$\therefore \rho \times g \times \frac{\pi}{4} D^2 \times L = \rho \times g \times \frac{\pi}{4} [D_o^2 - D_i^2] \times L$$

$$D^2 = D_o^2 - D_i^2 \quad \dots(i)$$

Now section modulus of solid section,

$$Z = \frac{\pi}{32} D^3 \quad [\text{See equation (7.9)}]$$

And section modulus of hollow section,

$$Z_1 = \frac{\pi}{32 D_o} [D_o^4 - D_i^4] \quad [\text{See equation (7.10)}]$$

$$= \frac{\pi}{32 D_o} [D_o^2 + D_i^2] [D_o^2 - D_i^2]$$

Section modulus of solid section

Section modulus of hollow section

$$= \frac{\frac{\pi}{32} D^3}{\frac{\pi}{32 D_o} [D_o^2 + D_i^2] [D_o^2 - D_i^2]}$$

$$= \frac{D^3 \times D_o}{[D_o^2 + D_i^2] [D_o^2 - D_i^2]} = \frac{D \times D_o \times D^2}{[D_o^2 + D_i^2] [D_o^2 - D_i^2]}$$

$$= \frac{D \times D_o \times [D_o^2 - D_i^2]}{[D_o^2 + D_i^2] (D_o^2 - D_i^2)} \quad [\because D^2 = D_o^2 - D_i^2 \text{ from equation (i)}]$$

$$= \frac{D \times D_o}{(D_o^2 + D_i^2)} \quad \dots(ii)$$

Also from equation (i),

$$D^2 = D_o^2 - D_i^2 \quad \text{or} \quad D_i^2 = D_o^2 - D^2$$

Substituting the value of  $D_i^2$  in equation (ii), we get

$$\frac{\text{Section modulus of solid shaft}}{\text{Section modulus of hollow shaft}} = \frac{D \times D_o}{D_o^2 + D_o^2 - D^2} = \frac{D \times D_o}{(2D_o^2 - D^2)}$$

$$\text{or} \quad \frac{\text{Section modulus of hollow shaft}}{\text{Section modulus of solid shaft}} = \frac{2D_o^2 - D^2}{D \times D_o} = \frac{2D_o^2}{D \times D_o} - \frac{D^2}{D \times D_o}$$

$$= 2 \frac{D_o}{D} - \frac{D}{D_o} \quad \text{Ans.}$$

**Problem 7.13.** A water main of 500 mm internal diameter and 20 mm thick is running full. The water main is of cast iron and is supported at two points 10 m apart. Find the maximum stress in the metal. The cast iron and water weigh 72000 N/m<sup>3</sup> and 10000 N/m<sup>3</sup> respectively.

(Annamalai University, 1990)

**Sol. Given :**

Internal dia.,  $D_i = 500 \text{ mm} = 0.5 \text{ m}$

Thickness of pipe,  $t = 20 \text{ mm}$

$\therefore$  Outer dia.,  $D_o = D_i + 2 \times t = 500 + 2 \times 20 = 540 \text{ mm} = 0.54 \text{ m}$

Weight density of cast iron = 72000 N/m<sup>3</sup>

Weight density of water = 10000 N/m<sup>3</sup>

Internal area of pipe =  $\frac{\pi}{4} D_i^2 = \frac{\pi}{4} \times 0.5^2 = 0.1960 \text{ m}^2$

This is also equal to the area of water section.

$\therefore$  Area of water section = 0.196 m<sup>2</sup>

Outer area of pipe =  $\frac{\pi}{4} D_o^2 = \frac{\pi}{4} \times 0.54^2 \text{ m}^2$

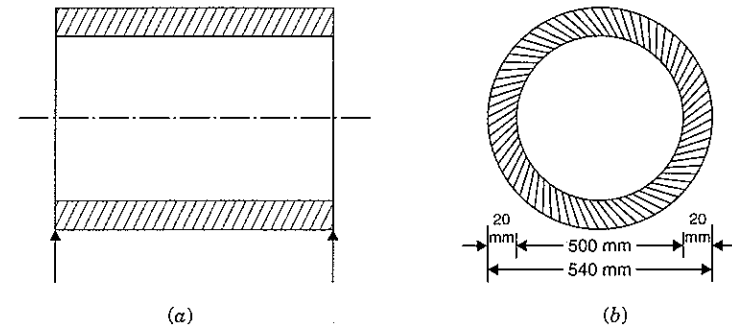

Fig. 7.17

$\therefore$  Area of pipe section =  $\frac{\pi}{4} D_o^2 - \frac{\pi}{4} D_i^2$

$$= \frac{\pi}{4} [D_o^2 - D_i^2] = \frac{\pi}{4} [0.54^2 - 0.5^2] = 0.0327 \text{ m}^2$$

Moment of inertia of the pipe section about neutral axis,

$$I = \frac{\pi}{64} [D_o^4 - D_i^4] = \frac{\pi}{64} [540^4 - 500^4] = 1.105 \times 10^9 \text{ mm}^4$$

Let us now find the weight of pipe and weight of water for one metre length.

Weight of the pipe for one metre run

$$\begin{aligned} &= \text{Weight density of cast iron} \times \text{Volume of pipe} \\ &= 72000 \times [\text{Area of pipe section} \times \text{Length}] \\ &= 72000 \times 0.0327 \times 1 \quad (\because \text{Length} = 1 \text{ m}) \\ &= 2354 \text{ N} \end{aligned}$$

Weight of the water for one metre run

$$\begin{aligned} &= \text{Weight density of water} \times \text{Volume of water} \\ &= 10000 \times (\text{Area of water section} \times \text{Length}) \\ &= 10000 \times 0.196 \times 1 = 1960 \text{ N} \end{aligned}$$

$$\begin{aligned} \therefore \text{Total weight on the pipe for one metre run} \\ &= 2354 + 1960 = 4314 \text{ N} \end{aligned}$$

Hence the above weight is the U.D.L. (uniformly distributed load) on the pipe. The maximum bending moment due to U.D.L. is  $w \times L^2/8$ , where  $w$  = Rate of U.D.L. = 4314 N per metre run.

$\therefore$  Maximum bending moment due to U.D.L.,

$$\begin{aligned} M &= \frac{w \times L^2}{8} = \frac{4314 \times 10^2}{8} \quad (\because L = 10 \text{ m}) \\ &= 53925 \text{ Nm} = 53925 \times 10^3 \text{ N mm} \end{aligned}$$

Now using

$$\frac{M}{I} = \frac{\sigma}{y}$$

$$\therefore \sigma = \frac{M}{I} \times y$$

The stress will be maximum, when  $y$  is maximum. But maximum value of

$$y = \frac{D_0}{2} = \frac{540}{2} = 270 \text{ mm.}$$

$$\therefore y_{\max} = 270 \text{ mm}$$

$$\begin{aligned} \therefore \text{Maximum stress, } \sigma_{\max} &= \frac{M}{I} \times y_{\max} = \frac{53925 \times 10^3}{1.105 \times 10^9} \times 270 \\ &= 13.18 \text{ N/mm}^2. \text{ Ans.} \end{aligned}$$

## 9. BENDING STRESS IN UNSYMMETRICAL SECTIONS

In case of symmetrical sections, the neutral axis passes through the geometrical centre of the section. But in case of unsymmetrical sections such as  $L$ ,  $T$  sections, the neutral axis does not pass through the geometrical centre of the section. Hence the value of  $y$  for the topmost layer or bottom layer of the section from neutral axis will not be same. For finding the bending stress in the beam, the bigger value of  $y$  is used. As the neutral axis passes through the centre of gravity of the section, hence in unsymmetrical sections, first the centre of gravity is calculated in the manner as explained in chapter 5.

**Problem 7.14.** A cast iron bracket subject to bending has the cross-section of  $I$ -form with unequal flanges. The dimensions of the section are shown in Fig. 7.18. Find the position of the neutral axis and moment of inertia of the section about the neutral axis. If the maximum bending moment on the section is 40 MN mm, determine the maximum bending stress. What is the nature of the stress?

**Sol. Given :**

$$\text{Max. B.M., } M = 40 \text{ MN mm} = 40 \times 10^6 \text{ Nmm}$$

Let us first calculate the C.G. of the section. Let  $\bar{y}$  is the distance of the C.G. from the bottom face. The section is symmetrical about  $y$ -axis and hence  $\bar{y}$  is only to be calculated. Then,

$$\bar{y} = \frac{A_1 y_1 + A_2 y_2 + A_3 y_3}{(A_1 + A_2 + A_3)}$$

where

$$A_1 = \text{Area of bottom flange} = 130 \times 50 = 6500 \text{ mm}^2$$

$$y_1 = \text{Distance of C.G. of } A_1 \text{ from bottom face}$$

$$= \frac{50}{2} = 25 \text{ mm}$$

$$A_2 = \text{Area of web} = 200 \times 50 = 10000 \text{ mm}^2$$

$$y_2 = \text{Distance of C.G. of } A_2 \text{ from bottom face}$$

$$= 50 + \frac{200}{2} = 150 \text{ mm}$$

$$A_3 = \text{Area of top flange} = 200 \times 50 = 10000 \text{ mm}^2$$

$$y_3 = \text{Distance of C.G. of } A_3 \text{ from bottom face}$$

$$= 50 + 200 + \frac{50}{2} = 275 \text{ mm.}$$

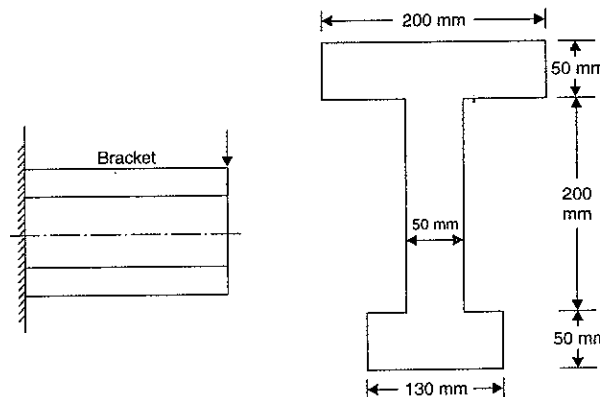

Fig. 7.18

$$\begin{aligned} \bar{y} &= \frac{6500 \times 25 + 10000 \times 150 + 10000 \times 275}{6500 + 10000 + 10000} \\ &= \frac{162500 + 1500000 + 2750000}{26500} \\ &= \frac{4412500}{26500} = 166.51 \text{ mm} \end{aligned}$$

Hence neutral axis is at a distance of 166.51 mm from the bottom face. **Ans.**

Moment of inertia of the section about the N.A.

$$I = I_1 + I_2 + I_3$$

where  $I_1$  = M.O.I. of bottom flange about N.A.

= M.O.I. of bottom flange about an axis passing through its C.G.

+  $A_1 \times (\text{Distance of its C.G. from N.A.})^2$

$$= \frac{130 \times 50^3}{12} + 6500 \times (166.51 - 25)^2$$

$$= 1354166.67 + 130163020 = 131517186.6 \text{ mm}^4$$

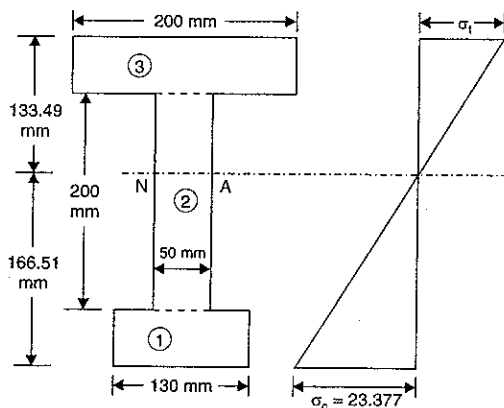

Fig. 7.19

Similarly

$I_2$  = M.O.I. of web about N.A.

$$= \frac{50 \times 200^3}{12} + A_2 \cdot (166.51 - y_2)^2$$

$$= \frac{50 \times 200^3}{12} + 10000 (166.51 - 150)^2$$

$$= 3333333.33 + 272580.1$$

$$= 33605913.43 \text{ mm}^4$$

and

$I_3$  = M.O.I. of top flange about N.A.

$$= \frac{200 \times 50^3}{12} + A_3 \cdot (y_3 - 166.51)^2$$

$$= \frac{200 \times 50^3}{12} + 10000 \times (275 - 166.51)^2$$

$$= 2083333.33 + 117700801 = 119784134.3 \text{ mm}^4$$

$$I = I_1 + I_2 + I_3 = 131517186.6 + 33605913.43 + 119784134.3$$

$$= 284907234.9 \text{ mm}^4. \text{ Ans.}$$

Now distance of C.G. from the upper top fibre

$$= 300 - \bar{y} = 300 - 166.51 = 133.49 \text{ mm}$$

and the distance of C.G. from the bottom fibre

$$= \bar{y} = 166.51 \text{ mm}$$

Hence we shall take the value of  $y = 166.51 \text{ mm}$  for maximum bending stress.

Now using the equation

$$\frac{M}{I} = \frac{\sigma}{y}$$

$$\therefore \sigma = \frac{M}{I} \times y = \frac{40 \times 10^6}{284907234.9} \times 166.51 = 23.377 \text{ N/mm}^2$$

$\therefore$  Maximum bending stress

$$= 23.377 \text{ N/mm}^2. \text{ Ans.}$$

This stress will be compressive. In case of cantilevers, upper layer is subjected to tensile stress, whereas the lower layer is subjected to compressive stress.

**Problem 7.15.** A cast iron beam is of I-section as shown in Fig. 7.20. The beam is simply supported on a span of 5 metres. If the tensile stress is not to exceed  $20 \text{ N/mm}^2$ , find the safe uniformly load which the beam can carry. Find also the maximum compressive stress.

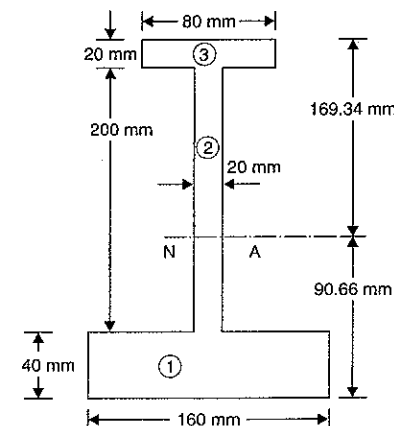

Fig. 7.20

**Sol. Given :**

Length of beam,  $L = 5 \text{ m}$

Maximum tensile stress,  $\sigma_t = 20 \text{ N/mm}^2$

First calculate the C.G. of the section. Let  $\bar{y}$  is the distance of the C.G. from the bottom face. As the section is symmetrical about  $y$ -axis, hence  $\bar{y}$  is only to be calculated.

$$\text{Now } \bar{y} = \frac{A_1 y_1 + A_2 y_2 + A_3 y_3}{(A_1 + A_2 + A_3)}$$

$$= \frac{(160 \times 40) \cdot \frac{40}{2} + (200 \times 20) \left(40 + \frac{200}{2}\right) + (80 \times 20) \cdot \left(40 + 200 + \frac{20}{2}\right)}{160 \times 40 + 200 \times 20 + 80 \times 20}$$

$$= \frac{128000 + 560000 + 400000}{6400 + 4000 + 1600} = \frac{1088000}{12000} = 90.66 \text{ mm}$$

N.A. lies at a distance of 90.66 mm from the bottom face or  $260 - 90.66 = 169.34$  mm from the top face.

Now moment of inertia of the section about N-axis is given by,

$$I = I_1 + I_2 + I_3$$

where  $I_1$  = M.O.I. of bottom flange about N.A.

$$= \text{M.O.I. of bottom flange about its C.G.} + A_1 \times (\text{Distance of its C.G. from N.A.})^2$$

$$= \frac{160 \times 40^3}{12} + 160 \times 40 \times (90.66 - 20)^2$$

$$= 853333.33 + 31954147.84 = 32807481.17 \text{ mm}^4$$

$I_2$  = M.O.I. of web about N.A.

$$= \text{M.O.I. of web about its C.G.} + A_2 \times (\text{Distance of its C.G. from N.A.})^2$$

$$= \frac{20 \times 200^3}{12} + 200 \times 20 \times (140 - 90.66)^2$$

$$= 13333333.33 + 9737742.4 = 23071075.73 \text{ mm}^4$$

$I_3$  = M.O.I. of top flange about N.A.

$$= \text{M.O.I. of top flange about its C.G.} + A_3 \times (\text{Distance of its C.G. from N.A.})^2$$

$$= \frac{80 \times 20^3}{12} + 80 \times 20 \times (250 - 90.66)^2$$

$$= 53333.33 + 40622776.96 = 40676110.29 \text{ mm}^4$$

$$\therefore I = 32807481.17 + 23071075.75 + 40676110.29 = 96554667.21 \text{ mm}^4$$

For a simply supported beam, the tensile stress will be at the extreme bottom fibre and compressive stress will be at the extreme top fibre.

Here maximum tensile stress =  $20 \text{ N/mm}^2$

Hence for the maximum tensile stress,

$$y = 90.66 \text{ mm}$$

[i.e.,  $y$  is the distance of the extreme bottom fibre (where the tensile stress is maximum) from the N.A.]

$$\text{Using the relation, } \frac{M}{I} = \frac{\sigma}{y}$$

$$\therefore M = \frac{\sigma}{y} \times I$$

$$= \frac{20}{90.66} \times 96554667.21 \quad (\because \sigma = \sigma_t = 20 \text{ N/mm}^2)$$

$$= 21300389.85 \text{ Nmm} \quad \dots(i)$$

Let  $w$  = Uniformly distributed load in N/m on the simply supported beam.

The maximum B.M. is at the centre and equal to  $\frac{wL^2}{8}$

$$\therefore M = \frac{w \times 5^2}{8} \text{ Nm} = \frac{w \times 25 \times 1000}{8} \text{ Nmm} = 3125 w \text{ Nmm} \quad \dots(ii)$$

Equating the two values of  $M$ , given by equation (i) and (ii), we get

$$3125w = 21300389.85$$

$$\therefore w = \frac{21300389.85}{3125} = 6816.125 \text{ N/m. Ans.}$$

Maximum Compressive Stress

Distance of extreme top fibre from N.A.,

$$y_c = 169.34 \text{ mm}$$

$$M = 21300389.85$$

$$I = 96554667.21$$

Let  $\sigma_c$  = Max. compressive stress

$$\text{Using the relation, } \frac{M}{I} = \frac{\sigma}{y}$$

$$\therefore \sigma = \frac{M}{I} \times y$$

$$\text{or } \sigma_c = \frac{M}{I} \times y_c = \frac{21300389.85}{96554667.21} \times 169.34 = 37.357 \text{ N/mm}^2. \text{ Ans.}$$

**Problem 7.16.** A cast iron beam is of T-section as shown in Fig. 7.21. The beam is simply supported on a span of 8 m. The beam carries a uniformly distributed load of 1.5 kN/m length on the entire span. Determine the maximum tensile and maximum compressive stresses.

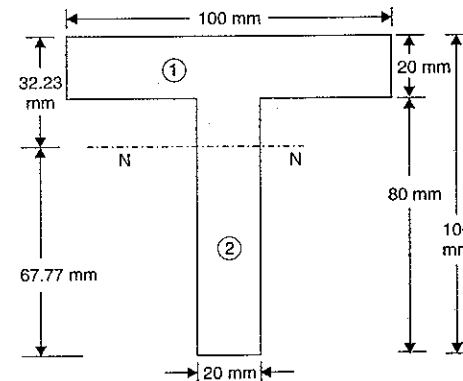

Fig. 7.21

Sol. Given :

Length,  $L = 8 \text{ m}$

U.D.L.,  $w = 1.5 \text{ kN/m} = 1500 \text{ N/m}$

To find the position of the N.A., the C.G. of the section is to be calculated first. The C.G. will be lying on the  $y$ - $y$  axis.

Let  $\bar{y}$  = Distance of the C.G. of the section from the bottom

$$\bar{y} = \frac{A_1 y_1 + A_2 y_2}{A_1 + A_2} = \frac{(100 \times 20) \times \left(80 + \frac{20}{2}\right) + 80 \times 20 \times \frac{80}{2}}{(100 \times 2) + (80 \times 20)}$$

$$= \frac{180000 + 64000}{2000 + 1600} = \frac{244000}{3600} = 67.77 \text{ mm}$$

∴ N.A. lies at a distance of 67.77 mm from the bottom face or  $100 - 67.77 = 32.23$  mm from the top face.

Now moment of inertia of the section about N.A. is given by,

$$I = I_1 + I_2$$

where  $I_1 = \text{M.O.I. of top flange about N.A.}$

$$= \text{M.O.I. of top flange about its C.G.} + A_1 \times (\text{Distance of its C.G. from N.A.})^2$$

$$= \frac{100 \times 20^3}{12} + (100 \times 20) \times (32.23 - 10)^2$$

$$= 66666.7 + 988345.8 = 1055012.5 \text{ mm}^4$$

$I_2 = \text{M.O.I. of web about N.A.}$

$$= \text{M.O.I. of web about its C.G.} + A_2 \times (\text{Distance of its C.G. from N.A.})^2$$

$$= \frac{20 \times 80^3}{12} + (80 \times 20) \times (67.77 - 40)^2$$

$$= 853333.3 + 1233876.6 = 2087209.9 \text{ mm}^4$$

$$I = I_1 + I_2 = 1055012.5 + 2087209.9 = 3142222.4 \text{ mm}^4$$

For a simply supported beam, the maximum tensile stress will be at the extreme bottom fibre and maximum compressive stress will be at the extreme top fibre.

Maximum B.M. is given by,

$$M = \frac{w \times L^2}{8} = \frac{1500 \times 8^2}{8} = 12000 \text{ Nm}$$

$$= 12000 \times 1000 = 12000000 \text{ Nmm}$$

Now using the relation

$$\frac{M}{I} = \frac{\sigma}{y} \quad \text{or} \quad \sigma = \frac{M}{I} \times y$$

(i) For maximum tensile stress,

$$y = \text{Distance of extreme bottom fibre from N.A.} = 67.77 \text{ mm}$$

$$\therefore \sigma = \frac{12000000}{3142222.4} \times 67.77 = 258.81 \text{ N/mm}^2. \quad \text{Ans.}$$

(ii) For maximum compressive stress,

$$y = \text{Distance of extreme top fibre from N.A.} = 32.23 \text{ mm}$$

$$\therefore \sigma = \frac{M}{I} \times y = \frac{12000000}{3142222.4} \times 32.23 = 123.08 \text{ N/mm}^2. \quad \text{Ans.}$$

**Problem 7.17.** A simply supported beam of length 3 m carries a point load of 12 kN at a distance of 2 m from left support. The cross-section of the beam is shown in Fig. 7.22 (b). Determine the maximum tensile and compressive stress at X-X.

**Sol.** Given :

Point load,  $W = 12 \text{ kN} = 12000 \text{ N}$

First find the B.M. at X-X. And to do this first calculate reactions  $R_A$  and  $R_B$ .

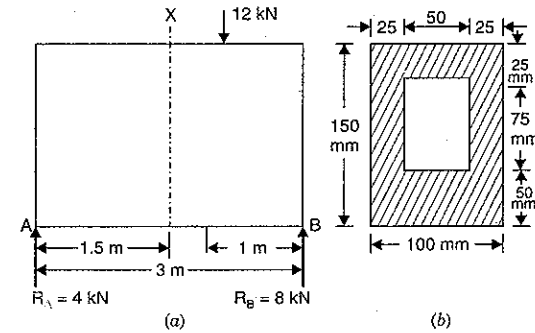

Fig. 7.22

Taking moments about A, we get

$$R_B \times 3 = 12 \times 2$$

$$\therefore R_B = \frac{12 \times 2}{3} = 8 \text{ kN} \quad \text{and} \quad R_A = W - R_B = 12 - 8 = 4 \text{ kN}$$

B.M. at X-X

$$= R_A \times 1.5 = 4 \times 1.5 = 6 \text{ kNm}$$

$$= 6 \times 1000 \text{ Nm} = 6000 \times 1000 \text{ Nmm}$$

$$= 6000000 \text{ Nmm}$$

∴

$$M = 6000000 \text{ Nmm}$$

Now find the position of N.A. of the section of the beam. This can be obtained if we know the position of C.G. of the section.

Let

$\bar{y}$  = Distance of the C.G. of the section from the bottom edge

$$= \frac{A_1 y_1 - A_2 y_2}{A_1 - A_2} \quad (\text{Negative sign is due to cut out part})$$

$$= \frac{(150 \times 100) \times 75 - (75 \times 50) \times \left(50 + \frac{75}{2}\right)}{150 \times 100 - 75 \times 50}$$

$$= \frac{1125000 - 328125}{15000 - 3750} = \frac{796875}{11250} = 70.83 \text{ mm}$$

Hence N.A. will lie at a distance of 70.83 mm from the bottom edge or  $150 - 70.83 = 79.17$  mm from the top edge as shown in Fig. 7.23.

Now the moment of inertia of the section about N.A. is given by,

$$I = I_1 - I_2$$

where  $I_1 = \text{M.O.I. of outer rectangle about N.A.}$

$$= \text{M.O.I. of rectangle } 100 \times 150 \text{ about its C.G.} + A_1$$

$$\times (\text{Distance of its C.G. from N.A.})^2$$

$$= \frac{100 \times 150^3}{12} + 100 \times 150 \times (75 - 70.83)^2$$

$$= 28125000 + 260833.5 = 28385833.5 \text{ mm}^4$$

$$\begin{aligned}
 I_2 &= \text{M.O.I. of cut out rectangular part about N.A.} \\
 &= \text{M.O.I. of cut out part about its C.G.} + A_2 \\
 &\quad \times (\text{Distance of its C.G. from N.A.})^2 \\
 &= \frac{50 \times 75^3}{12} + 50 \times 75 \\
 &\quad \times \left(50 + \frac{75}{2} - 70.83\right)^2 \\
 &= 1757812.5 + 1042083.375 \\
 &= 2799895.875 \text{ mm}^4 \\
 \therefore I &= I_1 - I_2 = 28385833.5 - 2799895.875 \\
 &= 25585937.63 \text{ mm}^4
 \end{aligned}$$

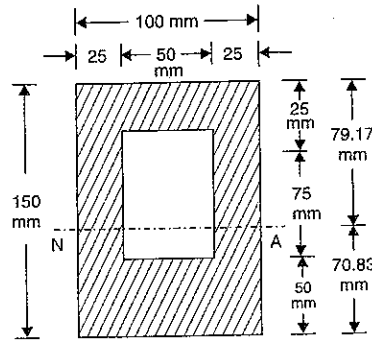

Fig. 7.23

The bottom edge of the section will be subjected to tensile stress whereas the top edge will be subjected to compressive stress. The top edge is at 79.17 mm from N.A. whereas bottom edge is 70.83 mm from N.A.

Now using the relation,

$$\frac{M}{I} = \frac{\sigma}{y}$$

$$\sigma = \frac{M}{I} \times y$$

(i) For maximum tensile stress,  $y = 70.83 \text{ mm}$

$\therefore$  Maximum tensile stress,

$$\sigma = \frac{6000000}{25585937.63} \times 70.83 = 16.60 \text{ N/mm}^2 \text{ Ans.}$$

(ii) For maximum compressive stress,

$$y = 79.17 \text{ mm.}$$

$\therefore$  Maximum compressive stress,

$$\sigma = \frac{M}{I} \times y = \frac{6000000}{25585937.63} \times 79.17 = 18.56 \text{ N/mm}^2 \text{ Ans.}$$

### 7.10. STRENGTH OF A SECTION

The strength of a section means the moment of resistance offered by the section and moment of resistance is given by,

$$M = \sigma \times Z \quad \left( \because \frac{M}{I} = \frac{\sigma}{y} \text{ or } M = \frac{\sigma}{y} \times I = \sigma \times Z \text{ where } Z = \frac{I}{y} \right)$$

where  $M$  = Moment of resistance

$\sigma$  = Bending stress, and

$Z$  = Section modulus.

For a given value of allowable stress, the moment of resistance depends upon the section modulus. The section modulus, therefore, represents the strength of the section. Greater the value of section modulus, stronger will be the section.

The bending stress at any point in any beam section is proportional to its distance from the neutral axis. Hence the maximum tensile and compressive stresses in a beam section are

proportional to the distances of the most distant tensile and compressive fibres from the neutral axis. Hence for the purposes of economy and weight reduction the material should be concentrated as much as possible at the greatest distance from the neutral axis. This idea is put into practice, by providing beams of I-section, where the flanges alone with-stand almost all the bending stress.

We know the relation :

$$\frac{M}{I} = \frac{\sigma}{y} \text{ or } \sigma = \frac{M}{I} \times y = \frac{M}{\left(\frac{I}{y}\right)} = \frac{M}{Z}$$

where  $Z$  = Section modulus.

For a given cross-section, the maximum stress to which the section is subjected due to a given bending moment depends upon the section modulus of the section. If the section modulus is small, then the stress will be more. There are some cases where an increase in the sectional area does not result in a decrease in stress. It may so happen that in some cases a slight increase in the area may result in a decrease in section modulus which result in an increase of stress to resist the same bending moment.

**Problem 7.18.** Three beams have the same length, same allowable bending stress and the same bending moment. The cross-section of the beams are a square, rectangle with depth twice the width and a circle. Find the ratios of weights of the circular and the rectangular beams with respect to square beams.

Sol. Given :

Fig. 7.24 shows a square, a rectangular and a circular section.

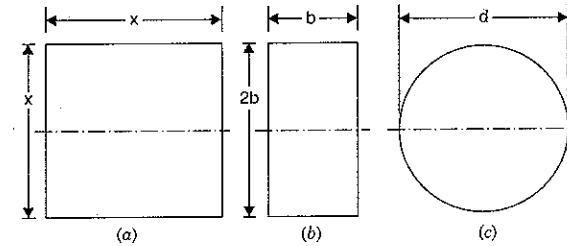

Fig. 7.24

Let  $x$  = Side of a square beam

$b$  = Width of rectangular beam

$\therefore 2b$  = Depth of the rectangular beam

$d$  = Diameter of a circular section.

The moment of resistance of a beam is given by,

$$M = \sigma \times Z$$

where  $Z$  = Section modulus.

As all the three beams have the same allowable bending stress ( $\sigma$ ), and same bending moment ( $M$ ), therefore the section modulus ( $Z$ ) of the three beams must be equal.



Section modulus of a square beam

$$\begin{aligned} &= \frac{I}{y} = \frac{bd^3}{\left(\frac{d}{2}\right)} = \frac{x \cdot x^3}{12} \times \frac{2}{x} \quad (\because b = d = x) \\ &= \frac{x^2}{6} \end{aligned}$$

Section modulus of a rectangular beam

$$\begin{aligned} &= \frac{bd^3}{\frac{d}{2}} = \frac{b \times (2b)^3}{\left(\frac{2b}{2}\right)} \quad (\because d = 2b) \\ &= \frac{b \times 8b^3}{12} \times \frac{2}{2b} = \frac{2}{3} b^3 \end{aligned}$$

Section modulus of a circular beam

$$\begin{aligned} &= \frac{\pi d^4}{\frac{d}{2}} = \frac{\pi d^4}{64} \times \frac{2}{d} = \frac{\pi d^3}{32} \end{aligned}$$

Equating the section modulus of a square beam with that of a rectangular beam, we get

$$\begin{aligned} \frac{x^3}{6} &= \frac{2}{3} b^3 \\ \therefore b^3 &= \frac{3x^3}{6 \times 2} = \frac{x^3}{4} = 0.25x^3 \\ b &= (0.25)^{1/3} x = 0.63x \quad \dots(i) \end{aligned}$$

Equating the section modulus of a square beam with that of a circular beam, we get

$$\begin{aligned} \frac{x^3}{6} &= \frac{\pi d^3}{32} \\ \therefore d^3 &= \frac{32x^3}{6\pi} \quad \text{or} \quad d = \left(\frac{32}{6\pi}\right)^{1/3} \cdot x = 1.1927x \end{aligned}$$

The weights of the beams are proportional to their cross-sectional areas. Hence

$$\begin{aligned} \frac{\text{Weight of rectangular beam}}{\text{Weight of square beam}} &= \frac{\text{Area of rectangular beam}}{\text{Area of square beam}} \\ &= \frac{b \times 2b}{x \times x} = \frac{0.63x \times 2 \times 0.63x}{x \times x} \\ &= \mathbf{0.7938. \quad \text{Ans.}} \end{aligned}$$

and

$$\begin{aligned} \frac{\text{Weight of circular beam}}{\text{Weight of square beam}} &= \frac{\text{Area of circular beam}}{\text{Area of square beam}} \\ &= \frac{\frac{\pi d^2}{4}}{x^2} = \frac{\pi d^2}{4x^2} = \frac{x \times (1.1927x)^2}{4x^2} \quad (\because d = 1.1927x) \\ &= \mathbf{1.1172. \quad \text{Ans.}} \end{aligned}$$

**Problem 7.19.** A beam is of square section of the side 'a'. If the permissible bending stress is ' $\sigma$ ', find the moment of resistance when the beam section is placed such that (i) two sides are horizontal, (ii) one diagonal is vertical. Find also the ratio of the moments of the resistance of the section in the two positions. (Bangalore University, July 1988)

**Sol. Given :**

Bending stress =  $\sigma$

**1st Case**

Fig. 7.25 (a) shows the square beam section when two sides are horizontal.

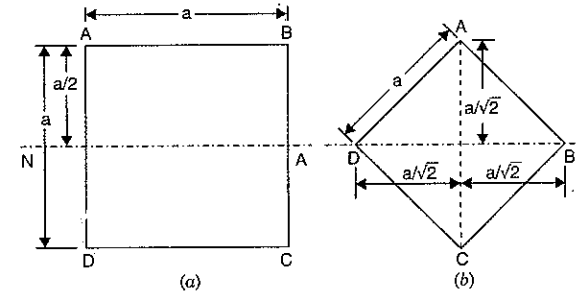

Fig. 7.25

Let  $M_1$  = Moment of resistance of the square beam when two sides are horizontal.

Moment of resistance is given by,

$$M = \sigma \times Z$$

$$\therefore M_1 = \sigma \times Z_1 \quad \dots(i)$$

where  $Z_1$  = Section modulus

$$= \frac{I}{y_{max}} = \frac{\frac{a \times a^3}{12}}{a/2} = \frac{a^4}{12} \times \frac{2}{a} = \frac{a^3}{6}$$

$$\therefore M_1 = \sigma \times \frac{a^3}{6} \quad \text{Ans.} \quad \dots(ii)$$

**2nd Case**

Fig. 7.25 (b) shows the square beam section when one diagonal is vertical.

Let  $M_2$  = Moment of resistance of the beam in this position

$$\therefore M_2 = \sigma \times Z_2$$

where  $Z_2$  = Section modulus for the section shown in Fig. 7.25 (b).

$$= \frac{I_2}{y_{max}} = \frac{2 \times \frac{bh^3}{12}}{\left(\frac{a}{\sqrt{2}}\right)}$$

$$\left( \because \text{M.O.I. of a triangle about its base} = \frac{bh^3}{12}. \text{ There are two triangles} \right)$$

$$= \frac{\frac{2}{12} \times \sqrt{2}a \left(\frac{a}{\sqrt{2}}\right)^3}{\left(\frac{a}{\sqrt{2}}\right)} \quad \left(\because \text{Here base} = b = \sqrt{2}a \text{ and } h = \frac{a}{\sqrt{2}}\right)$$

$$= \frac{a^3}{6 \times \sqrt{2}}$$

$$\therefore M_2 = \sigma \times \frac{a^3}{6 \times \sqrt{2}} \quad \text{Ans.}$$

Ratio of moment of resistance of the section in two positions

$$= \frac{M_1}{M_2} = \frac{\left(\frac{\sigma \times a^3}{6}\right)}{\left(\sigma \times \frac{a^3}{6 \times \sqrt{2}}\right)} = \sqrt{2} = 1.414 \quad \text{Ans.}$$

**Problem 7.20.** Prove that the moment of a resistance of a beam of square section, with its diagonal in the plane of bending is increased by flattening top and bottom corners as shown in Fig. 7.26 and that the moment of resistance is a maximum when  $y = \frac{8a}{9}$ . Find the percentage increase in moment of resistance also.

**Sol.** Given :

Fig. 7.26 (a) shows a square section with diagonal AC vertical. Let the portions AEF and CGH be cut off.

Let  $I_1$  = M.O.I. of the square ABCD about diagonal B.D.

$Z_1$  = Section modulus of square ABCD

$M_1$  = Moment of resistance of the square ABCD

$I_2$  = M.O.I. of the new section with cut off portion (i.e., M.O.I. of DEFBHG about diagonal BD)

$Z_2$  = Section modulus of new section

$M_2$  = Moment of resistance of the new section.

In Fig. 7.26 (a), diagonal AC = 2a

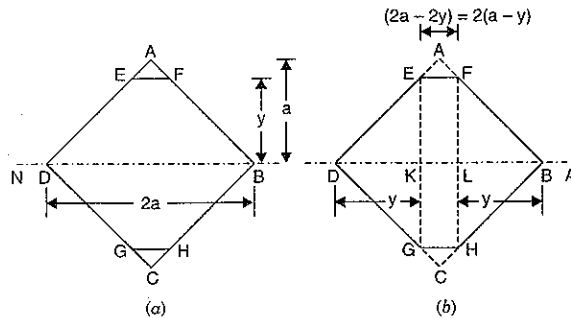

Fig. 7.26

$\therefore$  Diagonal  $DB = AC = 2a$ .

Now moment of inertia of the square ABCD about N.A. (i.e., diagonal BD) is given by

$$\therefore I_1 = \text{M.O.I. of two triangles ABD and BCD about their base BD}$$

$$= 2 \times \frac{bh^3}{12} = 2 \times \frac{2a \times a^3}{12} \quad (\text{Here } b = 2a \text{ and } h = a)$$

$$= \frac{a^4}{3}$$

$$\text{Section modulus, } Z_1 = \frac{I_1}{y_{max}} = \frac{\left(\frac{a^4}{3}\right)}{a} \quad (\text{Here } y_{max} = a)$$

$$= \frac{a^4}{3} \times \frac{1}{a} = \frac{1}{3} a^3$$

Moment of resistance is given by,

$$M = \sigma \times Z$$

$$\therefore M_1 = \sigma \times Z_1 = \sigma \times \frac{1}{3} a^3 = \sigma \times 0.3333a^3 \quad \dots(i)$$

Now the M.O.I. of the new section with cut off portion (i.e., M.O.I. of DEFBHG) about the diagonal BD is given by [Refer to Fig. 7.26 (b)].

$I_2$  = M.O.I. of four triangles (i.e., triangles DEK, FLB, DGH and HLB) plus M.O.I. of rectangle EFHG about N.A. (i.e., diagonal BD)

$$= \frac{4 \times bh^3}{12} + \frac{EF \times EG^3}{12} = \frac{4 \times y \times y^3}{12} + \frac{2(a-y) \times (2y)^3}{12}$$

$$\quad (\because \text{Here } b = y, h = y, EF = 2(a-y) \text{ and } EG = 2y)$$

$$= \frac{y^4}{3} + \frac{4}{3} (a-y) \times y^3 = \frac{y^4}{3} + \frac{4ay^3}{3} - \frac{4y^4}{3} = \frac{4}{3} ay^3 - y^4$$

and section modulus of new section is given by,

$$Z_2 = \frac{I_2}{y_{max}} = \frac{\frac{4}{3} ay^3 - y^4}{y} \quad (\because \text{Here } y_{max} = y)$$

$$= \frac{4}{3} ay^2 - y^3$$

Now moment of resistance of the new section is given by,

$$M_2 = \sigma \times Z_2 = \sigma \times \left[ \frac{4}{3} ay^2 - y^3 \right] \quad \dots(ii)$$

The moment of the resistance of the new section will be maximum, if  $\frac{dM_2}{dy} = 0$ .

Hence differentiating equation (ii) w.r.t. y and equating it to zero, we get

$$\frac{d}{dy} \left[ \sigma \left( \frac{4}{3} ay^2 - y^3 \right) \right] = 0$$

$$\text{or } \sigma \left( \frac{4}{3} a \times 2y - 3y^2 \right) = 0 \quad (\because \sigma \text{ and } a \text{ are constants})$$

$$\text{or } \frac{4}{3} a \times 2y - 3y^2 = 0 \quad (\because \sigma \text{ cannot be zero})$$

$$\therefore 3y^2 = \frac{8}{3} a \times y$$

$$\text{or } y = \frac{8}{3} \frac{a \times y}{3 \times y} = \frac{8a}{9} \quad \dots(iii)$$

Substituting this value of  $y$  in equation (ii), we get

$$(M_2)_{max} = \sigma \times \left[ \frac{4}{3} \times a \times \left( \frac{8a}{9} \right)^2 - \left( \frac{8a}{9} \right)^3 \right] = \sigma \times \left[ \frac{4 \times 64}{3 \times 81} a^3 - \frac{512}{729} a^3 \right]$$

$$= \sigma \times [1.0535a^3 - 0.7023a^3] = \sigma \times 0.3512 a^3 \quad \dots(iv)$$

But from equation (i),  $M_1 = \sigma \times 0.3333 a^3$

$\therefore M_2$  is more than  $M_1$ . And from equation (iii), it is clear that  $M_2$  is maximum when

$$y = \frac{8a}{9}. \quad \text{Ans.}$$

Now increase in moment of resistance

$$= (M_2)_{max} - M_1 = \sigma \times 0.3512 a^3 - \sigma \times 0.3333 a^3$$

$$= \sigma \times 0.0179 a^3$$

Percentage increase in moment of resistance

$$= \frac{\text{Increase in moment of resistance}}{\text{Original moment of resistance}} \times 100$$

$$= \frac{\sigma \times 0.0179 \times a^3}{\sigma \times 0.3333 \times a^3} \times 100 = 5.37\%. \quad \text{Ans.}$$

**Problem 7.21.** Prove that the ratio of depth to width of the strongest beam that can be cut from a circular log of diameter  $d$  is 1.414. Hence calculate the depth and width of the strongest beam that can be cut of a cylindrical log of wood whose diameter is 300 mm.

**Sol.** Given :

Dia. of log =  $d$

Let  $ABCD$  be the strongest rectangular section which can be cut out of the cylindrical log.

Let  $b$  = Width of strongest section.

$d$  = Depth of strongest section.

Now section modulus of the rectangular section

$$Z = \frac{I}{y} = \frac{\left( \frac{bh^3}{12} \right)}{\left( \frac{h}{2} \right)} = \frac{bh^2}{6} \quad \dots(i)$$

In the above equation,  $b$  and  $h$  are variable.

From  $\triangle BCD$ ,  $b^2 + h^2 = d^2$

$$h^2 = d^2 - b^2$$

or

Substituting the value of  $h^2$  in equation (i), we get

$$Z = \frac{b}{6} [d^2 - b^2] = \frac{1}{6} [bd^2 - b^3] \quad \dots(ii)$$

In the above equation,  $d$  is constant and hence only variable is  $b$ .

Now for the beam to be strongest, the section modulus should be maximum (or  $Z$  should be maximum).

For maximum value of  $Z$ ,

$$\frac{dZ}{db} = 0$$

$$\text{or } \frac{d}{db} \left[ \frac{bd^2 - b^3}{6} \right] = 0 \quad \text{or } \frac{d^2 - 3b^2}{6} = 0$$

$$\text{or } d^2 - 3b^2 = 0 \quad \text{or } d^2 = 3b^2 \quad \dots(iii)$$

But from triangle  $BCD$ ,

$$d^2 = b^2 + h^2$$

Substituting the value of  $d^2$  in equation (iii), we get

$$b^2 + h^2 = 3b^2 \quad \text{or } h^2 = 2b^2$$

$$\text{or } h = \sqrt{2} \times b \quad \dots(iv)$$

$$\text{or } \frac{h}{b} = \sqrt{2} = 1.414. \quad \text{Ans.}$$

**Numerical Part**

Given,  $d = 300$  mm

But for equation (iii),  $d^2 = 3b^2$  or  $3b^2 = d^2 = 300^2 = 90000$

$$\text{or } b^2 = \frac{90000}{3} = 30000$$

$$\therefore b = (30000)^{1/2} = 173.2 \text{ mm. Ans.}$$

From equation (iv),

$$h = \sqrt{2} \times b = 1.414 \times 173.2 = 249.95 \text{ mm. Ans.}$$

### 7.11. COMPOSITE BEAMS (FLITCHED BEAMS)

A beam made up of two or more different materials assumed to be rigidly connected together and behaving like a single piece is known as a composite beam or a wooden flitched beam. Fig. 7.27 (a) shows a wooden beam (or timber beam) reinforced by steel plates. This arrangement is known as composite beam or a flitched beam. The strain at the common surfaces will be same for both materials. Also the total moment of resistance will be equal to the sum of the moments of individual sections.

When such a beam is subjected to bending, the bending stresses and hence strains due to bending stresses at a point are proportional to the distance of the point from the common neutral axis. Consider the composite beam as shown in Fig. 7.27 (a) and let at a distance  $y$  from the N.A., the stresses in steel and wood are  $f_1$  and  $f_2$  respectively.

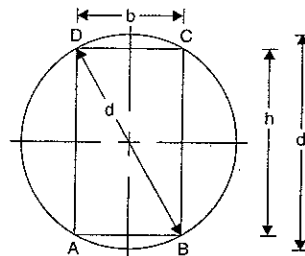

Fig. 7.27

Let  $E_1$  = Young's modulus of steel plate  
 $I_1$  = Moment of inertia of steel about N.A.  
 $M_1$  = Moment of resistance of steel  
 $E_2$  = Young's modulus of wood  
 $I_2$  = M.O.I. of wood about N.A.  
 $M_2$  = Moment of resistance of wood.  
 Strain in steel at a distance  $y$  from N.A.

$$= \frac{\text{Stress}}{E} = \frac{\sigma_1}{E_1}$$

( $\therefore$  Stress in steel =  $\sigma_1$ )

Strain in wood at a distance  $y$  from N.A.

$$= \frac{\sigma_2}{E_2}$$

But strain at the common surface is same

$$\therefore \frac{\sigma_1}{E_1} = \frac{\sigma_2}{E_2} \quad \dots(7.11)$$

$$\sigma_1 = \frac{E_1}{E_2} \times \sigma_2 = m \times \sigma_2 \quad \dots(i)$$

where  $m = \frac{E_1}{E_2}$  and is known as modular ratio between steel and wood.

Using the relation  $\frac{M}{I} = \frac{\sigma}{y}$ , we get

$$M = \frac{\sigma}{y} \times I$$

Hence moment of resistance of steel and wood are given by,

$$M_1 = \frac{\sigma_1}{y} \times I_1 \quad \text{and} \quad M_2 = \frac{\sigma_2}{y} \times I_2$$

$\therefore$  Total moment of resistance of the composite section,

$$\begin{aligned} M &= M_1 + M_2 \\ &= \frac{\sigma_1}{y} \times I_1 + \frac{\sigma_2}{y} \times I_2 \\ &= \frac{m\sigma_2 \times I_1}{y} + \frac{\sigma_2}{y} \times I_2 \quad (\because \sigma_1 = m\sigma_2 \text{ from equation } i) \\ &= \frac{\sigma_2}{y} [mI_1 + I_2] \quad \dots(7.12) \end{aligned}$$

In equation (7.12)  $I_2 + mI_1$  can be treated as equivalent moment of inertia of the cross-section, as if all made of material 2 (i.e., wood) which will give the same amount of resistance as the composite beam. Let this be denoted by  $I$ .

$$\therefore I = mI_1 + I_2 \quad \dots(7.13)$$

$$\text{Then } M = \frac{\sigma_2}{y} \times I \quad \dots(7.14)$$

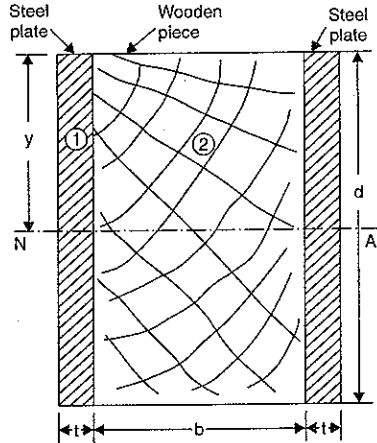

Fig. 7.27 (a)

The equivalent section is produced by using  $I = I_2 + mI_1$ . This can be done by multiplying the dimensions of the material 1 in the direction parallel to the N.A. by  $m$ . The equivalent figure can be used for finding the position of N.A. and equivalent moment of inertia.

**Problem 7.22.** A flitched beam consists of a wooden joist 10 cm wide and 20 cm deep strengthened by two steel plates 10 mm thick and 20 cm deep as shown in Fig. 7.28. If the maximum stress in the wooden joist is 7 N/mm<sup>2</sup>, find the corresponding maximum stress attained in steel. Find also the moment of resistance of the composite section. Take Young's modulus for steel =  $2 \times 10^5$  N/mm<sup>2</sup> and for wood =  $1 \times 10^4$  N/mm<sup>2</sup>.

**Sol.** Given :

Let suffix 1 represent steel and suffix 2 represent wooden joist.

Width of wooden joist,  $b_2 = 10$  cm

Depth of wooden joist,  $d_2 = 20$  cm

Width of one steel plate,  $b_1 = 1$  cm

Depth of one steel plate,  $d_1 = 20$  cm

Number of steel plates = 2

Max. stress in wood,  $\sigma_2 = 7$  N/mm<sup>2</sup>

$E$  for steel,  $E_1 = 2 \times 10^5$  N/mm<sup>2</sup>

$E$  for wood,  $E_2 = 1 \times 10^4$  N/mm<sup>2</sup>

Now M.O.I. of wooden joist about N.A.,

$$\begin{aligned} I_2 &= \frac{b_2 d_2^3}{12} = \frac{10 \times 20^3}{12} \\ &= 6666.66 \text{ cm}^4 \\ &= 6666.66 \times 10^4 \text{ mm}^4 \end{aligned}$$

M.O.I. of two steel plates about N.A.,

$$\begin{aligned} I_1 &= \frac{2 \times b_1 d_1^3}{12} = \frac{2 \times 1 \times 20^3}{12} \\ &= 1333.33 \text{ cm}^4 = 1333.33 \times 10^4 \text{ mm}^4. \end{aligned}$$

Now modular ratio between steel and wood is given by,

$$m = \frac{E_1}{E_2} = \frac{2 \times 10^5}{1 \times 10^4} = 20$$

The equivalent moment of inertia ( $I$ ) is given by equation (7.13).

$$\begin{aligned} \therefore I &= mI_1 + I_2 \\ &= 20 \times 1333.33 \times 10^4 + 6666.66 \times 10^4 \\ &= 10^4(26666.6 + 6666.66) = 10^4 \times 33333.2 \end{aligned}$$

Moment of resistance of the composite section is given by equation (7.14).

$$\begin{aligned} \therefore M &= \frac{\sigma_2}{y} \times I \\ &= \frac{7 \times 10^4 \times 33333.2}{10 \times 10} \quad (\because y = 10 \text{ cm} = 10 \times 10 \text{ mm}) \\ &= 233332.4 \times 10^2 \text{ N mm} = \mathbf{23333.24 \text{ Nm. Ans.}} \end{aligned}$$

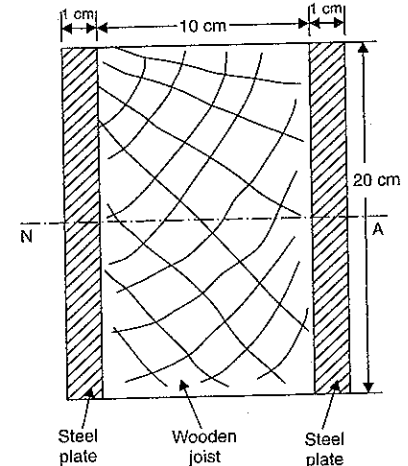

Fig. 7.28

**Maximum Stress in Steel**

Let  $\sigma_1 = \text{Max. stress in steel.}$

Now using equation, we get

$$\frac{\sigma_1}{E_1} = \frac{\sigma_2}{E_2}$$

$$\therefore \sigma_1 = \frac{E_1}{E_2} \times \sigma_2$$

$$= 20 \times 7$$

$$= 140 \text{ N/mm}^2. \text{ Ans.}$$

$$\left( \because \frac{E_1}{E_2} = m = 20 \text{ and } \sigma_2 = 7 \text{ N/mm}^2 \right)$$

**2nd Method**

Total moment of resistance is equal to the sum of moment of resistance of individual member.

$$\therefore M = M_1 + M_2 \quad \dots(i)$$

$$\text{where } M_1 = \frac{\sigma_1}{y} \times I_1 \quad \left( \because \frac{M}{I} = \frac{\sigma}{y} \right)$$

$$= \frac{140}{100} \times 1333.33 \times 10^4 \quad (\because y = 10 \times 10 = 100 \text{ mm})$$

$$= 18666620 \text{ Nmm} = 18666.620 \text{ Nm}$$

$$\text{and } M_2 = \frac{\sigma_2}{y} \times I_2$$

$$= \frac{7}{100} \times 6666.66 \times 10^4 \text{ Nmm}$$

$$= 46666.62 \text{ Nmm} = 4666.662 \text{ Nm}$$

$$\therefore M = M_1 + M_2 = 18666.620 + 4666.662$$

$$= 23333.282 \text{ Nm. Ans.}$$

**3rd Method**

The equivalent moment of inertia ( $I$ ) is obtained by producing equivalent section.

(a) The equivalent wooden section is obtained by multiplying the dimension of steel plate in the direction parallel to the N.A. by the modular ratio between steel and wood (i.e., by

multiplying by  $\frac{E_s}{E_w} = \frac{2 \times 10^5}{1 \times 10^4} = 20$ ). But the

width of one steel plate parallel to N.A. is 1 cm. Hence equivalent wooden width for this steel plate will be  $20 \times 1 = 20$  cm. This is shown in Fig. 7.29.

$\therefore$  Equivalent M.O.I. is given by,

$$I = \frac{bd^3}{12}$$

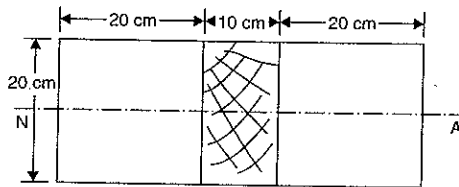

Fig. 7.29. Equivalent wooden section

$$= \frac{(20 + 10 + 20) \times 20^3}{12}$$

$$= 33333.33 \text{ cm}^4 = 33333.33 \times 10^4 \text{ mm}^4$$

$\therefore$  Total moment of resistance

= Moment of resistance of the equivalent wooden section

$$= \frac{\sigma}{y} \times I$$

$$= \frac{\text{Stress in wood}}{y} \times I$$

$$= \frac{7}{100} \times 33333.33 \times 10^4 = 23333333.33 \text{ Nmm}$$

$$= 23333.333 \text{ Nm. Ans.}$$

(b) The equivalent steel section is obtained by multiplying the dimensions of wooden joist in the direction parallel to N.A. by the modular ratio between wood and steel (i.e., by

multiplying by  $\frac{E_w}{E_s} = \frac{1 \times 10^4}{2 \times 10^5} = \frac{1}{20}$ ).

But the width of wooden joist parallel to N.A. is 10 cm. Hence equivalent steel width will be  $10 \times \frac{1}{20} = 0.5$  cm. This is shown in

Fig. 7.30.

Hence equivalent M.O.I. is given by

$$I = \frac{bd^3}{12}$$

$$= \frac{(1 + 0.5 + 1) \times 20^3}{12}$$

$$= 1666.66 \text{ cm}^4$$

$$= 1666.66 \times 10^4 \text{ mm}^4$$

$$\therefore M = \frac{\sigma}{y} \times I$$

$$= \frac{140}{100} \times 1666.66 \times 10^4$$

(Here  $\sigma$  is the stress in steel and  $= 140 \text{ N/mm}^2$ )

$$= 23333240 \text{ Nmm}$$

$$= 23333.240 \text{ Nm. Ans.}$$

**Note.** The width of the single wooden beam for the total moment of resistance of 23333.33 Nm should be  $20 + 10 + 20 = 50$  cm as shown in Fig. 7.29. But the width of flitched beam for the same moment of resistance is only  $1 + 10 + 1 = 12$  cm as shown in Fig. 7.28. Hence flitched beams require less space.

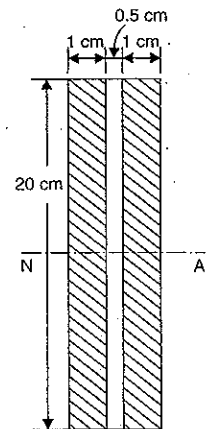

Fig. 7.30. Equivalent steel section

**Problem 7.23.** A timber beam 100 mm wide and 200 mm deep is to be reinforced by bolting on two steel flitches each 150 mm by 12.5 mm in section. Calculate the moment of resistance in the following cases : (i) flitches attached symmetrically at the top and bottom ; (ii) flitches attached symmetrically at the sides. Allowable stress in timber is 6 N/mm<sup>2</sup>. What is the maximum stress in the steel in each case ? Take  $E_s = 2 \times 10^5 \text{ N/mm}^2$  and  $E_t = 1 \times 10^4 \text{ N/mm}^2$ .

**Sol. Given :**

**1st Case.** Flitches attached symmetrically at the top and bottom.

(See Fig. 7.31).

Let suffix 1 represents steel and suffix 2 represents timber.

Width of steel,  $b_1 = 150 \text{ mm}$

Depth of steel,  $d_1 = 12.5 \text{ mm}$

Width of timber,  $b_2 = 100 \text{ mm}$

Depth of timber,  $d_2 = 200 \text{ mm}$

Number of steel plates = 2

Max. stress in timber,  $\sigma_2 = 6 \text{ N/mm}^2$

$E$  for steel,  $E_1 = E_s = 2 \times 10^5 \text{ N/mm}^2$

$E$  for timber,  $E_2 = E_t = 1 \times 10^4 \text{ N/mm}^2$

Distance of extreme fibre of timber from N.A.,

$$y_2 = 100 \text{ mm}$$

Distance of extreme fibre of steel from N.A.,

$$y_1 = 100 + 12.5 = 112.5 \text{ mm.}$$

Let  $\sigma_1^*$  = Max. stress in steel

$\sigma_1$  = Stress in steel at a distance of 100 mm from N.A.

Now we know that strain at the common surface is same. The strain at a common distance of 100 mm from N.A. is steel and wood would be same. Hence using equation (7.11), we get

$$\frac{\sigma_1}{E_1} = \frac{\sigma_2}{E_2}$$

$$\sigma_1 = \frac{E_1}{E_2} \times \sigma_2 = \frac{2 \times 10^5}{1 \times 10^4} \times 6 = 120 \text{ N/mm}^2.$$

But  $\sigma_1$  is the stress in steel at a distance of 100 mm from N.A. Maximum stress in steel would be at a distance of 112.5 mm from N.A. As bending stresses are proportional to the distance from N.A.

Hence 
$$\frac{\sigma_1}{100} = \frac{\sigma_1^*}{112.5}$$

$$\sigma_1^* = \frac{112.5}{100} \times \sigma_1 = \frac{112.5}{100} \times 120 = 135 \text{ N/mm}^2. \text{ Ans.}$$

Now moment of resistance of steel is given by

$$\begin{aligned} M_1 &= \frac{\sigma_1^*}{y_1} \times I_1 \text{ (where } \sigma_1^* \text{ is the maximum stress in steel)} \\ &= \frac{135}{112.5} \times I_1 \end{aligned}$$

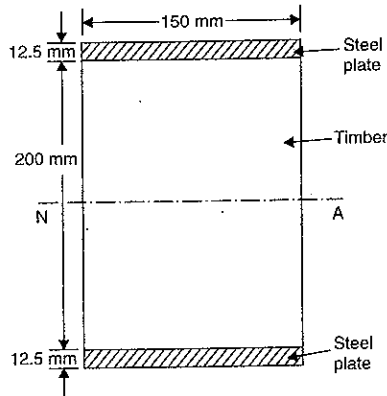

Fig. 7.31

where

$I_1 = \text{M.O.I. of two steel plates about N.A.}$

$$= 2 \times [\text{M.O.I. one steel plate about its C.G.} + \text{Area of one steel plate} \times (\text{Distance between its C.G. and N.A.})^2]$$

$$= 2 \times \left[ \frac{b_1 d_1^3}{12} + b_1 d_1 \times \left( 100 + \frac{d_1}{2} \right)^2 \right]$$

$$= 2 \times \left[ \frac{150 \times 12.5^3}{12} + 150 \times 12.5 \times \left( 100 + \frac{12.5}{2} \right)^2 \right]$$

$$= 2 \times [24414.06 + 21166992.18]$$

$$= 42382812.48 \text{ mm}^4$$

$$\therefore M_1 = \frac{135}{112.5} \times 42382812.48 = 50859374.96 \text{ Nmm} = 50859.375 \text{ Nm}$$

Similarly,  $M_2 = \frac{\sigma_2}{y_2} \times I_2$

$$= \frac{6}{100} \times \frac{150 \times 200^3}{12}$$

$$= 6000000 \text{ Nmm} = 6000 \text{ Nm}$$

$\therefore$  Total moment of resistance is given by,

$$\begin{aligned} M &= M_1 + M_2 \\ &= 50859.375 + 6000 = 56859.375 \text{ Nm. Ans.} \end{aligned}$$

**2nd Case.** Flitches attached symmetrically at the sides (See Fig. 7.32)

Here distance of the extreme fibre of steel from N.A.

$$= \frac{150}{2} = 75 \text{ mm.}$$

In the first case we have seen that stress in steel at a distance of 100 mm from N.A. is 120 N/mm<sup>2</sup>.

Hence the stress in steel at a distance of 75 mm from N.A. is given by,

$$\sigma_1^{**} = \frac{120}{100} \times 75$$

( $\because$  Stress are proportional to the distance from N.A.)

$$= 90 \text{ N/mm}^2$$

$\therefore$  Maximum stress in steel

$$= \sigma_1^{**} = 90 \text{ N/mm}^2. \text{ Ans.}$$

Total moment of resistance is given by,

$$M = M_1 + M_2$$

where  $M_1 = \text{Moment of resistance of two steel plates}$

$$= \frac{\sigma_1^{**}}{y_{max}} \times I_1$$

(Here  $\sigma_1^{**} = \text{Maximum stress in steel} = 90 \text{ N/mm}^2$ )

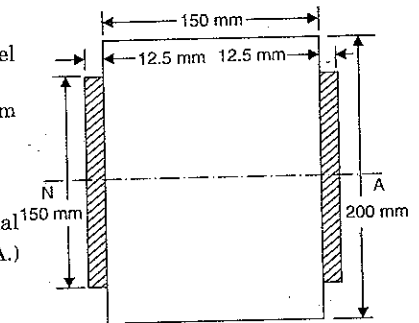

Fig. 7.32

$$= \frac{90}{75} \times I_1$$

$I_1 = \text{M.O.I. of two steel plates about N.A.}$

$$= 2 \times \frac{12.5 \times 150^3}{12} = 7031250 \text{ mm}^4$$

$$\therefore M_1 = \frac{90}{75} \times 7031250 \text{ Nmm} = 8437500 \text{ Nmm} = 8437.5 \text{ Nm.}$$

Similarly,  $M_2 = \text{Moment of resistance of timber section}$

$$= \frac{\sigma_2}{y_2} \times I_2$$

$$= \frac{6}{100} \times \frac{150 \times 200^3}{12}$$

$$= 6000000 \text{ Nmm} = 6000 \text{ Nm}$$

$\therefore$  Total moment of resistance,

$$M = M_1 + M_2$$

$$= 8437.5 + 6000 = 14437.5 \text{ Nm. Ans.}$$

**Problem 7.24.** Two rectangular plates, one of steel and the other of brass each 40 mm wide and 10 mm deep are placed together to form a beam 40 mm wide and 20 mm deep, on two supports 1 m apart, the brass plate being on the top of the steel plate. Determine the maximum load, which can be applied at the centre of the beam, if the plates are :

(i) separate and can bend independently,

(ii) firmly secured throughout their length.

Maximum allowable stress in steel = 112.5 N/mm<sup>2</sup> and in brass = 75 N/mm<sup>2</sup>. Take  $E_s = 2 \times 10^5 \text{ N/mm}^2$  and  $E_b = 8 \times 10^4 \text{ N/mm}^2$ .

**Sol.** Given :

Width of plates,  $b = 40 \text{ mm}$

Depth of plates,  $d = 10 \text{ mm}$

Span,  $L = 1 \text{ m}$

Stress in steel,  $\sigma_s = 112.5 \text{ N/mm}^2$

Stress in brass,  $\sigma_b = 75 \text{ N/mm}^2$

Value of  $E$  for steel,  $E_s = 2 \times 10^5 \text{ N/mm}^2$

Value of  $E$  for brass,  $E_b = 8 \times 10^4 \text{ N/mm}^2$ .

**1st Case.** The plates are separate and can bend independently.

Since the two materials bend independently, each will have its own neutral axis. It will be assumed that the radius of curvature  $R$  is the same for both the plates.

Using the relation  $\frac{\sigma}{y} = \frac{E}{R}$

$$R = \frac{E \times y}{\sigma}$$

$$R = \frac{E_s \times y_s}{\sigma_s} = \frac{E_b \times y_b}{\sigma_b}$$

$$\frac{\sigma_s}{\sigma_b} = \frac{E_s \times y_s}{E_b \times y_b}$$

$$(y_{max} = 75 \text{ mm})$$

$$\left( \therefore I_2 = \frac{150 \times 200^3}{12} \right)$$

But  $y_s = y_b$  as the two plates are having their own N.A. The distance of the extreme fibre of brass from its own N.A. is 5 mm. Also the distance of extreme fibre of steel from its N.A. = 5 mm.

$$\therefore \frac{\sigma_s}{\sigma_b} = \frac{E_s}{E_b} = \frac{2 \times 10^5}{8 \times 10^4} = 2.5$$

Now the allowable stress in steel is 112.5 N/mm<sup>2</sup>

$$\text{i.e., } \sigma_s = 112.5 \text{ N/mm}^2.$$

Then maximum stress in brass will be,

$$\sigma_b = \frac{\sigma_s}{2.5} = \frac{112.5}{2.5} = 45 \text{ N/mm}^2$$

This is less than the allowable stress of 75 N/mm<sup>2</sup>.

**Note.** If maximum stress in brass is taken as 75 N/mm<sup>2</sup>. Then the stress in steel will be  $\sigma_s = 2.5 \times \sigma_b = 2.5 \times 75 = 187.5 \text{ N/mm}^2$ . This stress is more than the allowable stress in steel.

The total moment of resistance is given by,

$$M = M_s + M_b$$

where  $M_s = \text{Moment of resistance of steel plate.}$

$$= \frac{\sigma_s}{y_s} \times I_s$$

$$= \frac{112.5}{5.0} \times \frac{40 \times 10^3}{12}$$

$$= 75000 \text{ Nmm} = 75 \text{ Nm}$$

and

$M_b = \text{Moment of resistance of brass plate}$

$$= \frac{\sigma_b}{y_b} \times I_b$$

$$= \frac{45}{5.0} \times \frac{40 \times 10^3}{12} = 30000 \text{ Nmm} = 30 \text{ Nm}$$

$$\therefore M = M_s + M_b = 75 + 30$$

$$= 105 \text{ Nm}$$

...(i)

Let  $W = \text{Maximum load applied at the centre in N to a simply supported beam.}$

Then maximum bending moment will be at the centre of the beam. And it is equal to,

$$M = \frac{W \times L}{4} = \frac{W \times 1.0}{4} \text{ Nm}$$

...(ii)

Equation (i) and (ii), we get

$$\frac{W}{4} = 105 \text{ or } W = 4 \times 105 = 420 \text{ N. Ans.}$$

**2nd Case.** The plates are firmly secured throughout their length.

In this case, the two plates act as a single unit and thus will have a single N.A. Let us convert the composite section into an equivalent brass section as shown in Fig. 7.34 (b).

The equivalent brass section is obtained by multiplying the dimensions of steel plate in the direction parallel to the N.A. by the modular ratio between steel and brass (i.e., by

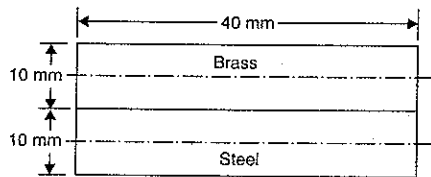

Fig. 7.33

multiplying by  $\frac{E_s}{E_b} = 2.5$ . But the width of steel plate parallel to N.A. is 40 mm. Hence equivalent brass width for the steel plate will be  $40 \times 2.5 = 100$  mm. This is shown in Fig. 7.34.

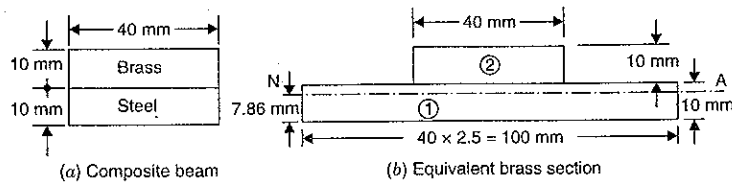

Fig. 7.34

Let  $\bar{y}$  = Distance between C.G. of the equivalent brass section and bottom face.

$$\begin{aligned} &= \frac{A_1 y_1 + A_2 y_2}{A_1 + A_2} \\ &= \frac{100 \times 10 \times 5 + 40 \times 10 \times (10 + 5)}{100 \times 10 + 40 \times 10} \\ &= \frac{5000 + 6000}{1000 + 400} = \frac{11000}{1400} = 7.86 \text{ mm.} \end{aligned}$$

Hence N.A. of the equivalent brass section is at a distance of 7.86 mm from the bottom face.

Now the moment of inertia of the equivalent brass section about N.A. is given as

$$\begin{aligned} I &= [\text{M.O.I. of rectangle } 100 \times 10 \text{ about its C.G.} \\ &\quad + \text{Area of rectangle } 100 \times 10 \times (\text{Distance between its C.G. and N.A.})^2] \\ &\quad + [\text{M.O.I. of rectangle } 40 \times 10 \text{ about its C.G.} + \text{Area of rectangle } 40 \times 10 \\ &\quad \times (\text{Distance between its C.G. and N.A.})^2] \\ &= \left[ \frac{100 \times 10^3}{12} + 100 \times 10 \times (7.86 - 5)^2 \right] + \frac{40 \times 10^3}{12} + 40 \times 10 \times [5 + (10 - 7.86)]^2 \\ &= 8333.33 + 8179.6 + 3333.33 + 20391.84 \\ &= 40238.1 \text{ mm}^4. \end{aligned}$$

Distance of upper extreme fibre from N.A.

$$= 20 - 7.86 = 12.14 \text{ mm}$$

Distance of lower extreme fibre from N.A.

$$= 7.86 \text{ mm}$$

Now allowable stress in brass is given  $75 \text{ N/mm}^2$ . As the upper plate is of brass.

Hence the upper extreme fibre will have a stress of  $75 \text{ N/mm}^2$ . Then the lowermost fibre

will have the stress  $= \frac{75}{12.14} \times 7.86 = 48.56 \text{ N/mm}^2$ . In Fig. 7.34 (b), the lowermost fibre is also of brass. Hence the actual stress in the lowermost fibre of steel will be

$$= 48.56 \times 2.5 = 121.4 \text{ N/mm}^2.$$

But the safe stress in steel is given as  $112.5 \text{ N/mm}^2$ . Hence the brass cannot be fully stressed.

If we take maximum stress in steel at the bottom to be  $112.5 \text{ N/mm}^2$ , then the corresponding stress in brass at the bottom fibre will be

$$\frac{112.5}{2.5} = 45 \text{ N/mm}^2.$$

$$\therefore \sigma_s = 112.5 \text{ N/mm}^2 \text{ and } \sigma_b = 45 \text{ N/mm}^2.$$

Now using the relation,

$$\frac{M}{I} = \frac{\sigma}{y}$$

or

$$M = \frac{\sigma}{y} \times I$$

$$\begin{aligned} &= \frac{45}{7.86} \times 40238.1 = 230370.8 \text{ Nmm} \\ &= 230.3708 \text{ Nm} \end{aligned} \quad \dots(iii)$$

The maximum bending moment at the centre of a simply supported beam, carrying a point load  $W$  at the centre is given by,

$$M = \frac{W \times L}{4} = \frac{W \times 1.0}{4} \quad \dots(iv)$$

Equating (iii) and (iv), we get

$$\frac{W}{4} = 230.3708$$

$$\therefore W = 4 \times 230.3708 = 921.48 \text{ N. Ans.}$$

### HIGHLIGHTS

1. The stresses produced due to constant bending moment (with zero shear force) are known as bending stresses.
2. The bending equation is given by,

$$\frac{M}{I} = \frac{\sigma}{y} = \frac{E}{R}$$

where  $M$  = Bending moment

$\sigma$  = Bending stress

$I$  = Moment of inertia about N.A.

$y$  = Distance of the fibre from N.A.

$R$  = Radius of curvature

$E$  = Young's modulus of beam.

3. The bending stress in any layer is directly proportional to the distance of the layer from the neutral axis (N.A.).
4. The bending stress on the neutral axis is zero.
5. The neutral axis of a symmetrical section (such as circular, rectangular or square) lies at a distance of  $\frac{d}{2}$  from the outermost layer of the section where  $d$  is the depth of the section.



- If the top layer of the section is subjected to compressive stress then the bottom layer of the section will be subjected to tensile stress.
- The ratio of moment of inertia of a section about the neutral axis to the distance of the outermost layer from the neutral axis is known as section modulus. It is denoted by  $Z$ .

$$Z = \frac{I}{y_{max}}$$

- Section modulus for various sections are given as :

$$Z = \frac{bd^2}{6} \quad \dots \text{For rectangular section}$$

$$= \frac{1}{6D} (BD^3 - bd^3) \quad \dots \text{For a hollow rectangular section}$$

$$= \frac{\pi d^3}{32} \quad \dots \text{For a circular section}$$

$$= \frac{\pi}{32D} [D^4 - d^4] \quad \dots \text{For a hollow circular section.}$$

- For finding bending stresses in unsymmetrical section, first their C.G. is to be obtained. This gives the position of N.A. The bigger value of  $y$  is to be used in bending equation.
- The moment of resistance offered by the section is known as the strength of the section.
- A beam made up of two or more different materials assumed to be rigidly connected together and behaving like a single unit, is known as a composite beam or flitched beam.
- The strain at the common surface of a composite beam is same.

$$\frac{\sigma_1}{E_1} = \frac{\sigma_2}{E_2}$$

- The ratio of  $\frac{E_1}{E_2}$  is known as modular ratio of first material to the second material.
- Total moment of resistance of a composite beam is the sum of the moment of resistance of individual section.

### EXERCISE 7

#### (A) Theoretical Questions

- Define the terms : bending stress in a beam, neutral axis and section modulus.
- What do you mean by 'simple bending' or 'pure bending' ? What are the assumptions made in the theory of simple bending ?
- Derive an expression for bending stress at a layer in a beam.
- What do you understand by neutral axis and moment of resistance ?
- Prove that relation,

$$\frac{M}{I} = \frac{\sigma}{y} = \frac{E}{R}$$

where  $M$  = Bending moment,  $I$  = M.O.I.  
 $\sigma$  = Bending stress,  $y$  = Distance from N.A.  
 $E$  = Young's modulus, and  $R$  = Radius of curvature.

(Bangalore University, Jan. 1990)

- What do you mean by section modulus ? Find an expression for section modulus for a rectangular, circular and hollow circular sections.
- How would you find the bending stress in unsymmetrical section ?
- What is the meaning of 'Strength of a section' ?
- Define and explain the terms : modular ratio, flitched beams and equivalent section.
- What is the procedure of finding bending stresses in case of flitched beams when it is of (i) a symmetrical section and (ii) an unsymmetrical section ?
- Explain the terms : Neutral axis, section modulus, and moment of resistance.  
(Bangalore University, July 1988)
- Show that for a beam subjected to pure bending, neutral axis coincides with the centroid of the cross-section.  
(Bangalore University, March 1989)
- Prove that the bending stress in any fibre is proportional to the distance of that fibre from neutral layer in a beam.  
(Bhavnagar University, 1992)

#### (B) Numerical Problems

- A steel plate of width 60 mm and of thickness 10 mm is bent into a circular arc of radius 10 m. Determine the maximum stress induced and the bending moment which will produce the maximum stress. Take  $E = 2 \times 10^5 \text{ N/mm}^2$ .  
[Ans.  $100 \text{ N/mm}^2$  ;  $100 \text{ Nm}$ ]
- A cast iron pipe of external diameter 60 mm, internal diameter of 40 mm, and of length 5 m is supported at its ends. Calculate the maximum bending stress induced in the pipe if it carries a point load of 100 N at its centre.  
[Ans.  $7.34 \text{ N/mm}^2$ ]
- A rectangular beam 300 mm deep is simply supported over a span of 4 m. What uniformly distributed load per metre, the beam may carry if the bending stress is not to exceed  $120 \text{ N/mm}^2$  ? Take  $I = 8 \times 10^6 \text{ mm}^4$ .  
[Ans.  $3.2 \text{ kN/m}$ ]
- A cast iron cantilever of length 1.5 metre fails when a point load  $W$  is applied at the free end. If the section of the beam is  $40 \text{ mm} \times 60 \text{ mm}$  and the stress at the failure is  $120 \text{ N/mm}^2$ , find the point load applied.  
[Ans.  $1.92 \text{ kN}$ ]
- A cast iron beam  $20 \text{ mm} \times 20 \text{ mm}$  in section and 100 cm long is simply supported at the ends. It carries a point load  $W$  at the centre. The maximum stress induced is  $120 \text{ N/mm}^2$ . What uniformly distributed load will break a cantilever of the same material 50 mm wide, 100 mm deep and 2 m long ?  
[Ans.  $5 \text{ kN per m run}$ ]
- A timber beam is 120 mm wide and 200 mm deep and is used on a span of 4 metres. The beam carries a uniformly distributed load of  $2.8 \text{ kN/m}$  run over the entire length. Find the maximum bending stress induced.  
[Ans.  $7 \text{ N/mm}^2$ ]
- A timber cantilever 200 mm wide and 300 mm deep is 3 m long. It is loaded with a U.D.L. of  $3 \text{ kN/m}$  over the entire length. A point load of  $2.7 \text{ kN}$  is placed at the free end of the cantilever. Find the maximum bending stress produced.  
[Ans.  $7.2 \text{ N/mm}^2$ ]
- A timber beam is freely supported on supports 6 m apart. It carries a uniformly distributed load of  $12 \text{ kN/m}$  run and a point load of  $9 \text{ kN}$  at 3.5 m from the right support. Design a suitable section of the beam making depth twice the width, if the stress in timber is not to exceed  $8 \text{ N/mm}^2$ .  
[Ans.  $230 \text{ mm} \times 460 \text{ mm}$ ]
- A beam of an I-section shown in Fig. 7.35 is simply supported over a span of 4 metres. Determine the load that the beam can carry per metre length, if the allowable stress in the beam is  $30.82 \text{ N/mm}^2$ .  
[Ans.  $2.5 \text{ kN/m run}$ ]

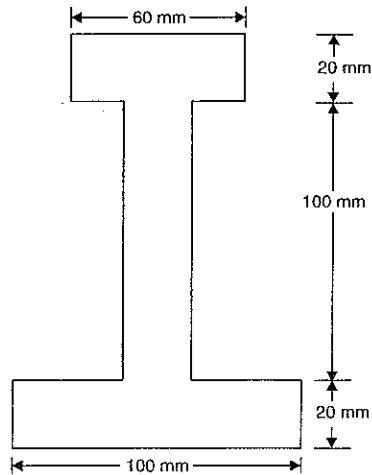

Fig. 7.35

10. A beam is of T-section as shown in Fig. 7.35. The beam is simply supported over a span of 4 m and carries a uniformly distributed load of 1.7 kN/m run over the entire span. Determine the maximum tensile and maximum compressive stress. [Ans. 8 N/mm<sup>2</sup> and 4.8 N/mm<sup>2</sup>]

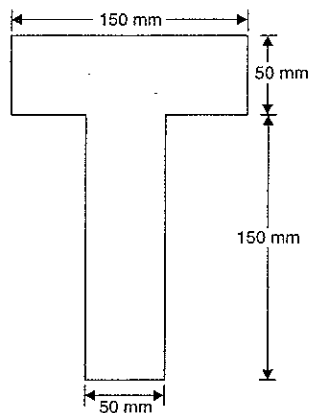

Fig. 7.36

11. A simply supported beam of length 4 m carries a point load of 16 kN at a distance of 3 m from left support. The cross-section of the beam is shown in Fig. 7.37. Determine the maximum tensile and compressive stress at a section which is at a distance of 2.25 m from the left support. [Ans. 24.9 N/mm<sup>2</sup> ; 27.84 N/mm<sup>2</sup>]

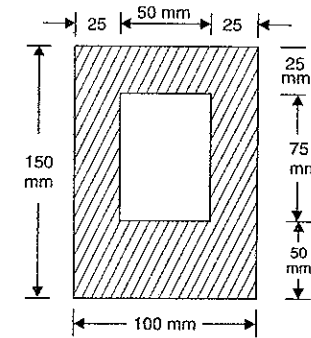

Fig. 7.37

12. Prove that the moment of resistance of a beam of square section is equal to  $\sigma \times \frac{x^3}{6}$  where ' $\sigma$ ' is the permissible stress in bending,  $x$  is the side of the square beam and beam is placed such that its two sides are horizontal.
13. Find the moment of resistance of the above beam, if it is placed such that its one diagonal is vertical, the permissible bending stress is same (i.e., equal to ' $\sigma$ '). [Ans.  $x^3 \times \sigma / 6 \times \sqrt{2}$ ]
14. A flitched beam consists of a wooden joist 150 mm wide and 300 mm deep strengthened by a steel plate 12 mm thick and 300 mm deep on either side of the joist. If the maximum stress in the wooden joist is 7 N/mm<sup>2</sup>, find the corresponding maximum stress attained in steel. Find also the moment of resistance of the composite section. Take  $E$  for steel =  $2 \times 10^5$  N/mm<sup>2</sup> and for wood =  $1 \times 10^4$  N/mm<sup>2</sup>. [Ans. 140 N/mm<sup>2</sup>, 66150 Nm]
15. A timber beam 60 mm wide by 80 mm deep is to be reinforced by bolting on two steel flitches, each 60 mm by 5 mm in section. Find the moment of resistance in the following cases : (i) flitches attached symmetrically at top and bottom ; (ii) flitches attached symmetrically at the sides. Allowable timber stress is 8 N/mm<sup>2</sup>. What is the maximum stress in the steel in each case ? Take  $E$  for steel =  $2.1 \times 10^5$  N/mm<sup>2</sup> and for timber =  $1.4 \times 10^4$  N/mm<sup>2</sup>. [Ans. (i) 3768 Nm,  $\sigma_s = 135$  N/mm<sup>2</sup> (ii) 1052 Nm,  $\sigma_s = 90$  N/mm<sup>2</sup>]
16. Two rectangular plates, one of steel and the other of brass each 37.5 mm by 10 mm are placed to form a beam 37.5 mm wide by 20 mm deep, on two supports 75 cm apart, the brass component being on top of the steel component. Determine the maximum central load if the plates are (i) separate and can bend independently, (ii) firmly secured throughout their length. Permissible stresses for brass and steel are 70 N/mm<sup>2</sup> and 100 N/mm<sup>2</sup>. Take  $E_b = 0.875 \times 10^5$  N/mm<sup>2</sup> and  $E_s = 2.1 \times 10^5$  N/mm<sup>2</sup>. [Ans. (i) 472.2 N (ii) 1043.5 N]
17. A timber beam 150 mm wide and 100 mm deep is to be reinforced by two steel flitches each 150 mm  $\times$  10 mm in section. Calculate the ratio of the moments of the resistance in the two-mentioned cases : (i) Flitches attached symmetrically on the sides (ii) Flitches attached at top and bottom. [Ans. 0.31]

## 8

## Shear Stresses in Beams

## 8.1. INTRODUCTION

In the last chapter, we have seen that when a part of a beam is subjected to a constant bending moment and zero shear force, then there will be only bending stresses in the beam. The shear stress will be zero as shear stress is equal to shear force divided by the area. As shear force is zero, the shear stress will also be zero.

But in actual practice, a beam is subjected to a bending moment which varies from section to section. Also the shear force acting on the beam is not zero. It also varies from section to section. Due to these shear forces, the beam will be subjected to shear stresses. These shear stresses will be acting across transverse sections of the beam. These transverse shear stresses will produce a complimentary horizontal shear stresses, which will be acting on longitudinal layers of the beam. Hence beam will also be subjected to shear stresses. In this chapter, the distribution of the shear stress across the various sections (such as Rectangular section, Circular section, I-section, T-sections etc.) will be determined.

## 8.2. SHEAR STRESS AT A SECTION

Fig 8.1 (a) shows a simply supported beam carrying a uniformly distributed load. For a uniformly distributed load, the shear force and bending moment will vary along the length of the beam. Consider two sections  $AB$  and  $CD$  of this beam at a distance  $dx$  apart.

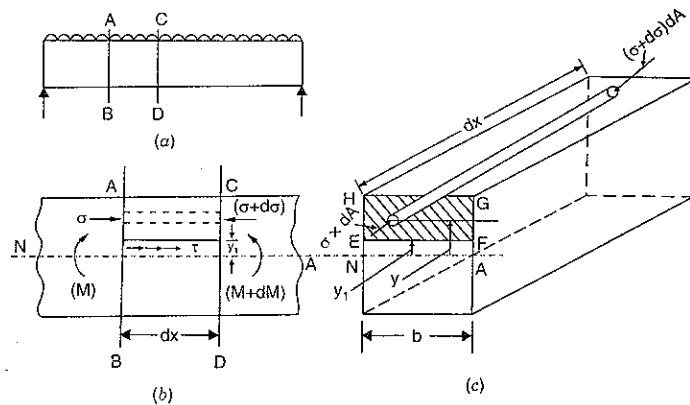

Area,  $A = \text{Area of } EFGH$

Fig. 8.1

Let at the section  $AB$ ,

$$F = \text{Shear force}$$

$$M = \text{Bending moment}$$

and at section  $CD$ ,  $F + dF = \text{Shear force}$

$$M + dM = \text{Bending moment}$$

$$I = \text{Moment of inertia of the section about the neutral axis.}$$

Let it is required to find the shear stress on the section  $AB$  at a distance  $y_1$  from the neutral axis. Fig. 8.1 (c) shows the cross-section of the beam. On the cross-section of the beam, let  $EF$  be a line at a distance  $y_1$  from the neutral axis. Now consider the part of the beam above the level  $EF$  and between the sections  $AB$  and  $CD$ . This part of the beam may be taken to consist of an infinite number of elemental cylinders each of area  $dA$  and length  $dx$ . Consider one such elemental cylinder at a distance  $y$  from the neutral axis.

$$\therefore dA = \text{Area of elemental cylinder}$$

$$dx = \text{Length of elemental cylinder}$$

$$y = \text{Distance of elemental cylinder from neutral axis}$$

Let  $\sigma = \text{Intensity of bending stress* on the end of the elemental cylinder on the section } AB$

$\sigma + d\sigma = \text{Intensity of bending stress on the end of the elemental cylinder on the section } CD.$

The bending stress at distance  $y$  from the neutral axis is given by equation (7.6) as

$$\frac{M}{I} = \frac{\sigma}{y}$$

$$\therefore \sigma = \frac{M}{I} \times y$$

For a given beam, the bending stress is a function of bending moment and the distance  $y$  from neutral axis. Let us find the bending stress on the end of the elemental cylinder at the section  $AB$  and also at the section  $CD$ .

$\therefore$  Bending stress on the end of elemental cylinder on the section  $AB$ , (where bending moment is  $M$ ) will be

$$\sigma = \frac{M}{I} \times y$$

Similarly, bending stress on the end of elemental cylinder on the section  $CD$ , (where bending moment is  $M + dM$ ) will be

$$\sigma + d\sigma = \frac{(M + dM)}{I} \times y$$

$$(\because \text{ On section } CD, \text{ B.M.} = M + dM \text{ and bending stress} = \sigma + d\sigma)$$

Now let us find the forces on the two ends of the elemental cylinder.

Force on the end of the elemental cylinder on the section  $AB$

$$= \text{Stress} \times \text{Area of elemental cylinder}$$

$$= \sigma \times dA$$

\*Bending stresses are acting normal to the cross-section.

$$= \frac{M}{I} \times y \times dA \quad \left( \because \sigma = \frac{M}{I} \times y \right)$$

Similarly, force on the end of the elemental cylinder on the section  $CD$

$$= (\sigma + d\sigma) dA$$

$$= \frac{(M + dM)}{I} \times y \times dA \quad \left[ \because \sigma + d\sigma = \frac{(M + dM)}{I} \times y \right]$$

At the two ends of the elemental cylinder, the forces are different. They are acting along the same line but are in opposite direction. Hence there will be unbalanced force on the elemental cylinder.

$\therefore$  Net unbalanced force on the elemental cylinder

$$= \frac{(M + dM)}{I} \times y \times dA - \frac{M}{I} \times y \times dA$$

$$= \frac{dM}{I} \times y \times dA \quad \dots(i)$$

The total unbalanced force above the level  $EF$  and between the two sections  $AB$  and  $CD$  may be found out by considering all the elemental cylinders between the sections  $AB$  and  $CD$  and above the level  $EF$  (i.e., by integrating the above equation (i)).

$\therefore$  Total unbalanced force

$$= \int \frac{dM}{I} \times y \times dA = \frac{dM}{I} \int y \times dA$$

$$= \frac{dM}{I} \times A \times \bar{y} \quad \left( \because \int y \times dA = A \times \bar{y} \right)$$

where  $A$  = Area of the section above the level  $EF$  (or above  $y_1$ )  
= Area of  $EFGH$  as shown in Fig. 8.1 (c)

$\bar{y}$  = Distance of the C.G. of the area  $A$  from the neutral axis.

Due to the total unbalanced force acting on the part of the beam above the level  $EF$  and between the sections  $AB$  and  $CD$  as shown in Fig. 8.2 (a), the beam may fail due to shear. Hence in order the above part may not fail by shear, the horizontal section of the beam at the level  $EF$  must offer a shear resistance. This shear resistance at least must be equal to total unbalanced force to avoid failure due to shear.

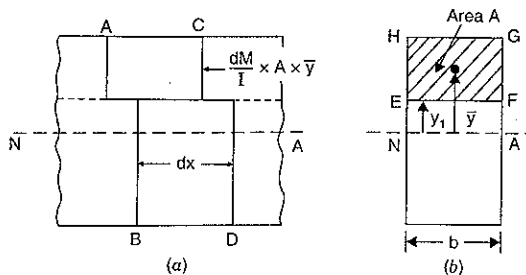

Fig. 8.2

$$\therefore \text{Shear resistance (or shear force) at the level } EF$$

$$= \text{Total unbalanced force}$$

$$= \frac{dM}{I} \times A \times \bar{y} \quad \dots(ii)$$

Let  $\tau$  = Intensity of horizontal shear at the level  $EF$   
 $b$  = Width of beam at the level  $EF$

$$\therefore \text{Area on which } \tau \text{ is acting}$$

$$= b \times dx$$

$$\therefore \text{Shear force due to } \tau$$

$$= \text{Shear stress} \times \text{Shear area}$$

$$= \tau \times b \times dx \quad \dots(iii)$$

Equating the two values of shear force given by equation (ii) and (iii), we get

$$\tau \times b \times dx = \frac{dM}{I} \times A \times \bar{y}$$

$$\therefore \tau = \frac{dM}{I} \times \frac{A \times \bar{y}}{b \times dx}$$

$$= \frac{dM}{dx} \cdot \frac{A\bar{y}}{I \times b}$$

$$= F \times \frac{A\bar{y}}{I \times b} \quad \left( \because \frac{dM}{dx} = F = \text{Shear force} \right) \quad \dots(8.1)$$

The shear stress given by equation (8.1) is the horizontal shear stress at the distance  $y_1$  from the neutral axis. But by the *principle of complementary shear*, the horizontal shear stress is accompanied by a vertical shear stress  $\tau$  of the same quantity.

Sometimes  $A \times \bar{y}$  is also expressed as the moment of area  $A$  about the neutral axis.

**Note.** In equation (8.1),  $b$  is the actual width at the level  $EF$  (Though here  $b$  is same at all levels, in many cases  $b$  may not be same at all levels) and  $I$  is the total moment of inertia of the section about N.A.

**Problem 8.1.** A wooden beam 100 mm wide and 150 mm deep is simply supported over a span of 4 metres. If shear force at a section of the beam is 4500 N, find the shear stress at a distance of 25 mm above the N.A.

**Sol.** Given :

Width,  $b = 100$  mm

Depth,  $d = 150$  mm

Shear force,  $F = 4500$  N

Let  $\tau$  = Shear stress at a distance of 25 mm above the neutral axis.

Using equation (8.1), we get

$$\tau = F \cdot \frac{A\bar{y}}{I \cdot b} \quad \dots(i)$$

where  $A$  = Area of the beam above  $y_1$

$$= 100 \times 50 = 5000 \text{ mm}^2$$

(Shaded area of Fig. 8.2)

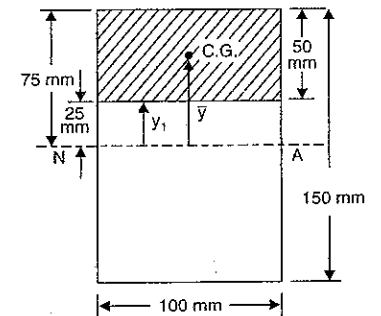

Fig. 8.3

$\bar{y}$  = Distance of the C.G. of the area  $A$  from neutral axis

$$= 25 + \frac{50}{2} = 50 \text{ mm}$$

$I$  = M.O.I. of the total section

$$= \frac{bd^3}{12}$$

$$= \frac{100 \times 150^3}{12} = 28125000 \text{ mm}^4$$

$b$  = Actual width of section at a distance  $y_1$  from N.A. = 100 mm

Substituting these values in the above equation (i), we get

$$\tau = \frac{4500 \times 5000 \times 50}{28125000 \times 100} = 0.4 \text{ N/mm}^2. \text{ Ans.}$$

**Problem 8.2.** A beam of cross-section of an isosceles triangle is subjected to a shear force of 30 kN at a section where base width = 150 mm and height = 450 mm. Determine :

- horizontal shear stress at the neutral axis,
- the distance from the top of the beam where shear stress is maximum, and
- value of maximum shear stress.

**Sol.** Given :

Shear force at the section,  $F = 30 \text{ kN} = 30,000 \text{ N}$

Base width,  $CD = 150 \text{ mm}$

Height,  $h = 450 \text{ mm}$ .

(i) Horizontal shear stress at the neutral axis

The neutral axis of the triangle is at a distance of  $\frac{h}{3}$  from

base or  $\frac{2h}{3}$  from the apex  $B$ . Hence distance of neutral axis from

$B$  will be  $\frac{2 \times 450}{3} = 300 \text{ mm}$  as shown in Fig. 8.3 (a). The width of

the section at neutral axis is obtained from similar triangles  $BCD$  and  $BNA$  as

$$\frac{NA}{CD} = \frac{300}{450}$$

$$\text{or } NA = \frac{300}{450} \times CD = \frac{300}{450} \times 150 = 100 \text{ mm.}$$

The shear stress at any section is given by equation (8.1) as

$$\tau = F \times \frac{A \times \bar{y}}{I \times b} \quad \dots(i)$$

where  $\tau$  = Shear stress at the section

$F$  = Shear force = 30,000 N

$A$  = Area above the axis at which shear stress is to be obtained  
[i.e., shaded area of Fig. 8.3 (a)]

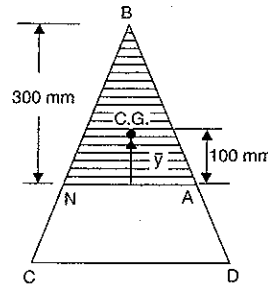

Fig. 8.3 (a)

$$= \frac{NA \times 300}{2} = \frac{100 \times 300}{2} = 15000 \text{ mm}^2$$

$\bar{y}$  = Distance of the C.G. of the area  $A$  from neutral axis

$$= \frac{1}{3} \times 300 = 100 \text{ mm}$$

$I$  = M.O.I. of the total section about neutral axis

$$= \frac{\text{Base width} \times \text{Height}^3}{36} \quad \left( \because \frac{B \times h^3}{36} \text{ where } B = \text{Base Width of Triangle} \right)$$

$$= \frac{150 \times 450^3}{36} \text{ mm}^4$$

$b$  = Actual width of the section at which shear stress is to be obtained  
=  $NA = 100 \text{ mm}$ .

Substituting these values in equation (i), we get

$$\tau = 30,000 \times \frac{15000 \times 100}{\left( \frac{150 \times 450}{36} \right)^3 \times 100} \text{ N/mm}^2$$

$$= 1.185 \text{ N/mm}^2. \text{ Ans.}$$

(ii) The distance from the top of the beam where shear stress is maximum

Let the shear stress is maximum at the section  $EF$  at a distance  $x$  from the top of the beam as shown in Fig. 8.3 (b). The distance  $EF$  is obtained from similar triangles  $BEF$  and  $BCD$  as

$$\frac{EF}{CD} = \frac{x}{450}$$

$$\therefore EF = \frac{x}{450} \times CD = \frac{x}{450} \times 150 = \frac{x}{3}$$

The shear stress at the section  $EF$  is given by equation (8.1) as

$$\tau = F \times \frac{A \times \bar{y}}{I \times b} \quad \dots(ii)$$

where  $F = 30,000 \text{ N}$

$A$  = Area of section above  $EF$  i.e., Area of shaded triangle  $BEF$

$$= \frac{EF \times x}{2} = \frac{x}{3} \times \frac{x}{2}$$

$$= \frac{x^2}{6}$$

$\bar{y}$  = Distance of C.G. of the Area  $A$  from neutral axis

$$= \frac{2h}{3} - \frac{2x}{3} = \frac{2 \times 450}{3} - \frac{2x}{3} = \left( 300 - \frac{2x}{3} \right)$$

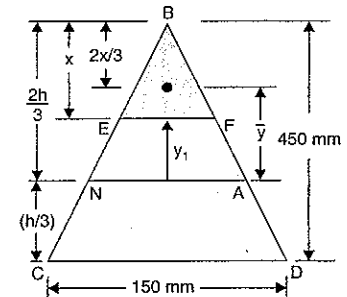

Fig. 8.3 (b)

$$\left( \because EF = \frac{x}{3} \right)$$

$I = \text{M.O.I. of } \triangle BCD \text{ about neutral axis}$

$$= \frac{150 \times 450^3}{36} \text{ mm}^4$$

$b = \text{Width of section } EF = \frac{x}{3}$

Substituting these values in equation (ii), we get

$$\tau = \frac{30,000 \times \left(\frac{x^2}{6}\right) \times \left(300 - \frac{2x}{3}\right)}{\left(\frac{150 \times 450^3}{36}\right) \times \frac{x}{3}} = 0.0000395x \left(300 - \frac{2x}{3}\right)$$

$$= 0.0000395 \left(300x - \frac{2x^2}{3}\right) \quad \dots(iii)$$

For maximum shear stress  $\frac{d\tau}{dx} = 0$

$$300 - \frac{2}{3} \times 2x = 0 \quad \text{or} \quad 300 = \frac{4x}{3}$$

$$x = \frac{300 \times 3}{4} = 225 \text{ mm. Ans.}$$

Hence, shear stress is maximum at a distance of 225 mm from the top of the beam.

(iii) Value of Maximum Shear Stress

The value of maximum shear stress will be obtained by substituting  $x = 225$  mm in equation (iii).

$$\begin{aligned} \therefore \text{Maximum shear stress} &= 0.0000395 \left(300 \times 225 - \frac{2}{3} \times 225^2\right) \\ &= 1.333 \text{ N/mm}^2. \text{ Ans.} \end{aligned}$$

### 8.3. SHEAR STRESS DISTRIBUTION FOR DIFFERENT SECTIONS

The following are the important sections over which the shear stress distribution is to be obtained :

1. Rectangular Section,
2. Circular Section,
3. I-Section,
4. T-Sections, and
5. Miscellaneous Sections.

**8.3.1. Rectangular Section.** Fig. 8.4 shows a rectangular section of a beam of width  $b$  and depth  $d$ . Let  $F$  is the shear force acting at the section. Consider a level  $EF$  at a distance  $y$  from the neutral axis.

The shear stress at this level is given by equation (8.1) as

$$\tau = F \cdot \frac{A\bar{y}}{b \times I}$$

where  $A = \text{Area of the section above } y \text{ (i.e., shaded area } ABFE)$

$$= \left(\frac{d}{2} - y\right) \times b$$

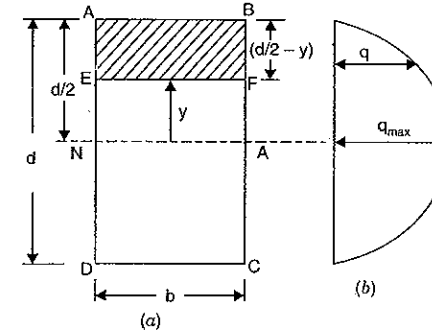

Fig. 8.4

$\bar{y} = \text{Distance of the C.G. of area } A \text{ from neutral axis}$

$$= y + \frac{1}{2} \left(\frac{d}{2} - y\right) = y + \frac{d}{4} - \frac{y}{2} = \frac{y}{2} + \frac{d}{4} = \frac{1}{2} \left(y + \frac{d}{2}\right)$$

$b = \text{Actual width of the section at the level } EF$

$I = \text{M.O.I. of the whole section about N.A.}$

Substituting these values in the above equation, we get

$$\begin{aligned} \tau &= \frac{F \cdot \left(\frac{d}{2} - y\right) \times b \times \frac{1}{2} \left(y + \frac{d}{2}\right)}{b \times I} \\ &= \frac{F}{2I} \left(\frac{d^2}{4} - y^2\right) \quad \dots(8.2) \end{aligned}$$

From equation (8.2), we see that  $\tau$  increases as  $y$  decreases. Also the variation of  $\tau$  with respect to  $y$  is a parabola. Fig. 8.4 (b) shows the variation of shear stress across the section.

At the top edge,  $y = \frac{d}{2}$  and hence

$$\tau = \frac{F}{2I} \left[\frac{d^2}{4} - \left(\frac{d}{2}\right)^2\right] = \frac{F}{2I} \times 0 = 0$$

At the neutral axis,  $y = 0$  and hence

$$\begin{aligned} \tau &= \frac{F}{2I} \left(\frac{d^2}{4} - 0\right) = \frac{F}{2I} \times \frac{d^2}{4} \\ &= \frac{Fd^2}{8I} = \frac{Fd}{8 \times \frac{bd^3}{12}} \quad \left(\because I = \frac{bd^3}{12}\right) \\ &= \frac{12}{8} \cdot \frac{F}{bd} = 1.5 \frac{F}{bd} \quad \dots(i) \end{aligned}$$

$$\text{Now average shear stress, } \tau_{avg} = \frac{\text{Shear force}}{\text{Area of section}} = \frac{F}{b \times d}$$

Substituting the above value in equation (i), we get

$$\tau = 1.5 \times \tau_{avg} \quad \dots(8.3)$$

Equation (8.3) gives the shear stress at the neutral axis where  $y = 0$ . This stress is also the maximum shear stress.

$$\therefore \tau_{max} = 1.5 \tau_{avg} \quad \dots(8.4)$$

From equation (8.1),  $\tau = \frac{A\bar{y}}{Ib}$ . In this equation the value of  $A\bar{y}$  can also be calculated as given below :

$$A\bar{y} = \text{Moment of shaded area of Fig. 8.4 (a) about N.A.}$$

Consider a strip of thickness  $dy$  at a distance  $y$  from N.A. Let  $dA$  is the area of this strip.

Then  $dA = \text{Area of strip} = b \times dy$

Moment of the area  $dA$  about N.A.

$$= dA \cdot y \text{ or } y \times dA$$

$$= y \times bdy \quad (\because dA = b \times dy)$$

The moment of the shaded area about N.A. is obtained by integrating the above equation between the limits  $y$  to  $\frac{d}{2}$ .

$\therefore$  Moment of shaded area about N.A.

$$= \int_y^{d/2} y \times b \times dy$$

$$= b \int_y^{d/2} y \times dy \quad (\text{as } b \text{ is constant})$$

$$= b \left[ \frac{y^2}{2} \right]_y^{d/2} = \frac{b}{2} \left[ \left( \frac{d}{2} \right)^2 - y^2 \right] = \frac{b}{2} \left[ \frac{d^2}{4} - y^2 \right]$$

But moment of shaded area about N.A. is also equal to  $A\bar{y}$

$$\therefore A\bar{y} = \frac{b}{2} \left[ \frac{d^2}{4} - y^2 \right]$$

Substituting the value of  $A\bar{y}$  in equation (8.1), we get

$$\tau = \frac{F \times \frac{b}{2} \left( \frac{d^2}{4} - y^2 \right)}{I \times b} = \frac{F}{2I} \left( \frac{d^2}{4} - y^2 \right)$$

This equation is same as equation (8.2).

**Problem 8.3.** A rectangular beam 100 mm wide and 250 mm deep is subjected to a maximum shear force of 50 kN. Determine :

(i) Average shear stress, (ii) Maximum shear stress, and

(iii) Shear stress at a distance of 25 mm above the neutral axis.

**Sol. Given :**

Width,  $b = 100 \text{ mm}$

Depth,  $d = 250 \text{ mm}$

Maximum shear force,  $F = 50 \text{ kN} = 50,000 \text{ N}$ .

(i) Average shear stress is given by,

$$\begin{aligned} \tau_{avg} &= \frac{F}{\text{Area}} = \frac{50,000}{b \times d} \\ &= \frac{50,000}{100 \times 250} = 2 \text{ N/mm}^2. \text{ Ans.} \end{aligned}$$

(ii) Maximum shear stress is given by equation (8.4)

$$\begin{aligned} \therefore \tau_{max} &= 1.5 \times \tau_{avg} \\ &= 1.5 \times 2 = 3 \text{ N/mm}^2. \text{ Ans.} \end{aligned}$$

(iii) The shear stress at a distance  $y$  from N.A. is given by equation (8.2).

$$\begin{aligned} \therefore \tau &= \frac{F}{2I} \left( \frac{d^2}{4} - y^2 \right) \\ &= \frac{50000}{2I} \left( \frac{250^2}{4} - 25^2 \right) \quad (\because y = 25 \text{ mm}) \\ &= \frac{50000}{2 \times \frac{bd^3}{12}} \left( \frac{62500}{4} - 625 \right) = \frac{50000 \times 12}{2 \times 100 \times 250^3} \times 15000 \text{ N/mm}^2 \\ &= 2.88 \text{ N/mm}^2. \text{ Ans.} \end{aligned}$$

**Alternate Method** [See Fig. 8.4 (d)]

The shear stress at a distance 25 mm from neutral axis is given by equation (8.1) as

$$\tau = F \times \frac{A \times \bar{y}}{I \times b}$$

where  $F = 50,000 \text{ N}$

$A = \text{Area of beam above 25 mm (i.e., shaded area in Fig. 8.4 (d))}$

$$= 100 \times 100 = 10000 \text{ mm}^2$$

$\bar{y} = \text{Distance of the C.G. of the area } A \text{ from neutral axis}$

$$= 25 + \frac{100}{2} = 75 \text{ mm}$$

$I = \text{M.O.I. of total section about neutral axis}$

$$= \frac{bd^3}{12} = \frac{100 \times 250^3}{12}$$

$b = \text{Actual width of the section at a distance 25 mm from neutral axis} = 100.$

Substituting these values in equation (8.1), we get

$$\tau = 50,000 \times \frac{10000 \times 75}{\left( \frac{100 \times 250^3}{12} \right) \times 100}$$

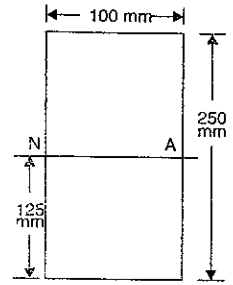

Fig. 8.4 (c)

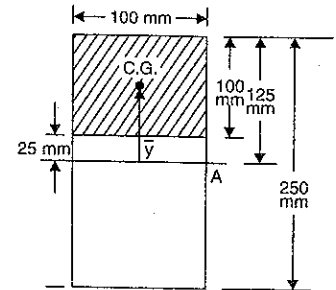

Fig. 8.4 (d)

$$= \frac{50000 \times 10000 \times 75 \times 12}{100 \times 250^3 \times 100} = 2.88 \text{ N/mm}^2. \text{ Ans.}$$

**Problem 8.4.** A timber beam of rectangular section is simply supported at the ends and carries a point load at the centre of the beam. The maximum bending stress is  $12 \text{ N/mm}^2$  and maximum shearing stress is  $1 \text{ N/mm}^2$ , find the ratio of the span to the depth.

**Sol. Given :**

Maximum bending stress,  $\sigma_{max} = 12 \text{ N/mm}^2$

Maximum shear stress,  $\tau_{max} = 1 \text{ N/mm}^2$ .

Let  $b$  = Width of the beam,

$d$  = Depth of the beam,

$L$  = Span of the beam,

$W$  = Point load at the centre.

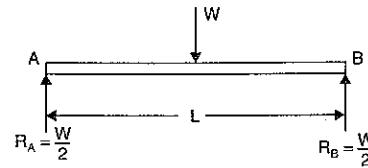

Fig. 8.5

Maximum shear force,  $F = \frac{W}{2}$

and maximum B.M.,  $M = \frac{W \times L}{4}$

Now average shear stress,  $\tau_{avg} = \frac{\text{Shear force}}{\text{Area}} = \frac{\left(\frac{W}{2}\right)}{b \times d} = \frac{W}{2bd}$

Maximum shear stress is given by equation (8.4)

$$\therefore \tau_{max} = 1.5 \times \tau_{avg}$$

$$1 = 1.5 \times \frac{W}{2bd} \quad \left( \because \tau_{max} = 1, \tau_{avg} = \frac{W}{2bd} \right)$$

$$\frac{W}{bd} = \frac{2}{1.5} = \frac{4}{3} \quad \dots(i)$$

Now using bending equation

$$\frac{M}{I} = \frac{\sigma}{y} \quad \text{or} \quad \sigma = \frac{M}{I} \times y$$

$\therefore$  Maximum bending stress,

$$\sigma_{max} = \frac{M}{I} \times y_{max}$$

$$= \frac{\frac{W \times L}{4} \times \frac{d}{2}}{\frac{bd^3}{12}} \quad \left( \because y_{max} = \frac{d}{2} \right)$$

$$= \frac{12}{8} \times \frac{W \cdot L \cdot d}{bd^3} = 1.5 \frac{W \cdot L}{bd^2}$$

$$12 = 1.5 \frac{W \cdot L}{bd^2} \quad \left( \because \sigma_{max} = 12 \right)$$

$$= 1.5 \frac{W}{bd} \cdot \frac{L}{d}$$

$$= 1.5 \times \frac{4}{3} \times \frac{L}{d} \quad \left[ \because \frac{W}{bd} = \frac{4}{3} \text{ from equation (i)} \right]$$

$$= 2 \times \frac{L}{d}$$

$$\frac{L}{d} = \frac{12}{2} = 6. \text{ Ans.}$$

**Problem 8.5.** A simply supported wooden beam of span  $1.3 \text{ m}$  having a cross-section  $150 \text{ mm}$  wide by  $250 \text{ mm}$  deep carries a point load  $W$  at the centre. The permissible stress are  $7 \text{ N/mm}^2$  in bending and  $1 \text{ N/mm}^2$  in shearing. Calculate the safe load  $W$ .

**Sol. Given :**

Span,  $L = 1.30 \text{ m}$

Width,  $b = 150 \text{ mm}$

Depth,  $d = 250 \text{ mm}$

Bending stress,  $\sigma = 7 \text{ N/mm}^2$

Shearing stress,  $\tau = 1 \text{ N/mm}^2$

Maximum B.M.,  $M = \frac{W \times L}{4} = \frac{W}{2} \times 1.3$

Nm

$$= \frac{W}{4} \times 1.3 \times 1000 \text{ Nmm} = 325 W \text{ Nmm}$$

Maximum S.F.  $= \frac{W}{2} \text{ N.}$

(i) Value of  $W$  for bending stress consideration

Using bending equation

$$\frac{M}{I} = \frac{\sigma}{y} \quad \dots(ii)$$

where  $M = 325 W \text{ Nmm}$

$$I = \frac{bd^3}{12} = \frac{150 \times 250^3}{12} = 195312500 \text{ mm}^4$$

$$\sigma = 7 \text{ N/mm}^2$$

and  $y = \frac{d}{2} = \frac{205}{2} = 125.$

Substituting these values in the above equation (i), we get

$$\frac{325W}{195312500} = \frac{7}{125}$$

$$W = \frac{7 \times 195312500}{325 \times 125} = 33653.8 \text{ N.}$$

(ii) Value of  $W$  for shear stress consideration

Average shear stress,

$$\tau_{avg} = \frac{\text{Shear force}}{\text{Area}} = \frac{\left(\frac{W}{2}\right)}{b \times d} = \frac{W}{2 \times 150 \times 250}$$

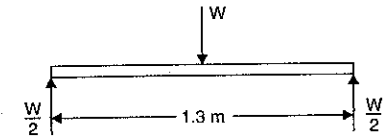

Fig. 8.6



Maximum shear stress is given by equation (8.4)

$$\therefore \tau_{max} = \frac{3}{2} \times \tau_{avg}$$

But  $\tau_{max} = 1 \text{ N/mm}^2$

$$\therefore 1 = \frac{3}{2} \times \frac{W}{2 \times 150 \times 250}$$

or  $W = \frac{2 \times 2 \times 150 \times 250}{3} = 50000 \text{ N.}$

Hence, the safe load is minimum of the two values (i.e., 33653.8 and 50000 N) of  $W$ . Hence safe load is 33653.8 N. **Ans.**

**8.3.2. Circular Section.** Fig. 8.7 shows a circular section of a beam. Let  $R$  is the radius of the circular section of  $F$  is the shear force acting on the section. Consider a level  $EF$  at a distance  $y$  from the neutral axis.

The shear stress at this level is given by equation (8.1) as

$$\tau = \frac{F \times A \times \bar{y}}{I \times b} \quad \dots(i)$$

where  $A\bar{y}$  = Moment of the shaded area about the neutral axis (N.A.)

$I$  = Moment of inertia of the whole circular section

$b$  = Width of the beam at the level  $EF$ .

Consider a strip of thickness  $dy$  at a distance  $y$  from N.A. Let  $dA$  is the area of strip.

Then  $dA = b \times dy = EF \times dy$  ( $\because b = EF$ )

$= 2 \times EB \times dy$  ( $\because EF = 2 \times EB$ )

$= 2 \times \sqrt{R^2 - y^2} \times dy$

( $\because$  In rt. angled triangle  $OEB$ , side  $EB = \sqrt{R^2 - y^2}$ )

Moment of this area  $dA$  about N.A.

$= y \times dA$

$= y \times 2 \sqrt{R^2 - y^2} \times dy$  ( $\because dA = 2 \sqrt{R^2 - y^2} dy$ )

$= 2y \sqrt{R^2 - y^2} dy.$

Moment of the whole shaded area about the N.A. is obtained by integrating the above equation between the limits  $y$  and  $R$

$$\therefore A\bar{y} = \int_y^R 2y \sqrt{R^2 - y^2} dy$$

$$= - \int_y^R (-2y) \sqrt{R^2 - y^2} dy.$$

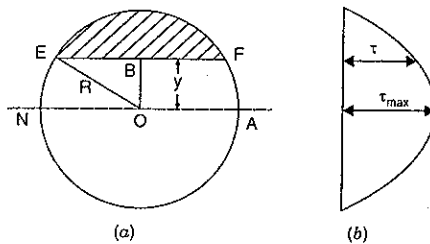

Fig. 8.7

Now  $(-2y)$  is the differential of  $(R^2 - y^2)$ . Hence, the integration of the above equation becomes as

$$A\bar{y} = - \left[ \frac{(R^2 - y^2)^{3/2}}{3/2} \right]_y^R$$

$$= - \frac{2}{3} [(R^2 - R^2)^{3/2} - (R^2 - y^2)^{3/2}]$$

$$= - \frac{2}{3} [0 - (R^2 - y^2)^{3/2}] = \frac{2}{3} (R^2 - y^2)^{3/2}$$

Substituting the value of  $A\bar{y}$  in equation (i), we get

$$\tau = \frac{F \times \frac{2}{3} (R^2 - y^2)^{3/2}}{I \times b}$$

But  $b = EF = 2 \times EB = 2 \times \sqrt{R^2 - y^2}$

Substituting this value of  $b$  in the above equation, we get

$$\tau = \frac{\frac{2}{3} F (R^2 - y^2)^{3/2}}{I \times 2 \sqrt{R^2 - y^2}} = \frac{F}{EI} (R^2 - y^2) \quad \dots(8.5)$$

Equation (8.5) shows that shear stress distribution across a circular section is parabolic. Also it is clear from this equation that with the increase of  $y$ , the shear stress decreases. At  $y = R$ , the shear stress,  $\tau = 0$ . Hence, shear stress will be maximum when  $y = 0$  i.e., at the neutral axis.

$\therefore$  At  $y = 0$  i.e., at the neutral axis, the shear stress is maximum and is given by

$$\tau_{max} = \frac{F}{3I} R^2$$

But  $I = \frac{\pi}{64} D^4 = \frac{\pi}{64} \times (2R)^4$  ( $\because D = 2R$ )

$$= \frac{\pi}{4} R^4$$

$$\therefore \tau_{max} = \frac{F \times R^2}{3 \times \frac{\pi}{4} R^4} = \frac{4}{3} \times \frac{F}{\pi R^2} \quad \dots(8.6)$$

But average shear stress,

$$\tau_{avg} = \frac{\text{Shear force}}{\text{Area of circular section}} = \frac{F}{\pi R^2}$$

Hence equation (8.6) becomes as,

$$\tau_{max} = \frac{4}{3} \times \tau_{avg} \quad \dots(8.7)$$

**Problem 8.6.** A circular beam of 100 mm diameter is subjected to a shear force of 5 kN. Calculate :

- (i) Average shear stress, (ii) Maximum shear stress, and  
(iii) Shear stress at a distance of 40 mm from N.A.

Sol. Given :

Diameter,  $D = 100 \text{ mm}$

∴ Radius,  $R = \frac{100}{2} = 50 \text{ mm}$

Shear force,  $F = 5 \text{ kN} = 5000 \text{ N}$ .

(i) Average shear stress is given by,

$$\begin{aligned}\tau_{avg} &= \frac{\text{Shear force}}{\text{Area of circular section}} \\ &= \frac{5000}{\pi(50)^2} = \mathbf{0.6366 \text{ N/mm}^2}. \text{ Ans.}\end{aligned}$$

(ii) Maximum shear stress for a circular section is given by equation (8.7).

$$\begin{aligned}\tau_{max} &= \frac{4}{3} \times \tau_{avg} \\ &= \frac{4}{3} \times 0.6366 = \mathbf{0.8488 \text{ N/mm}^2}. \text{ Ans.}\end{aligned}$$

(iii) The shear stress at a distance 40 mm from N.A. is given by equation (8.5).

$$\begin{aligned}\tau &= \frac{F}{3I} (R^2 - y^2) \\ &= \frac{5000}{3 \times \frac{\pi}{64} \times 100^4} (50^2 - 40^2) \quad \left( \because y = 40 \text{ and } I = \frac{\pi}{64} 100^4 \right) \\ &= \frac{5000 \times 64}{3 \times \pi \times 100000000} (2500 - 1600) \\ &= \mathbf{0.3055 \text{ N/mm}^2}. \text{ Ans.}\end{aligned}$$

### 8.3.3. I-Section

Fig. 8.8 shows the I-section of a beam.

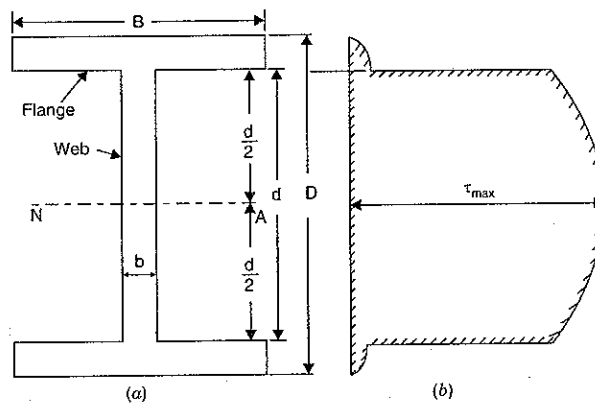

Fig. 8.8

Let

$B$  = Overall width of the section,

$D$  = Overall depth of the section,

$b$  = Thickness of the web, and

$d$  = Depth of web.

The shear stress at a distance  $y$  from the N.A., is given by equation (8.1) as

$$\tau = F \times \frac{A\bar{y}}{I \times b}$$

In this case the shear stress distribution in the web and shear stress distribution in the flange are to be calculated separately. Let us first calculate the shear stress distribution in the flange.

(i) Shear stress distribution in the flange

Consider a section at a distance  $y$  from N.A. in the flange as shown in Fig. 8.8 (c).

Width of the section =  $B$

Shaded area of flange,  $A = B \left( \frac{D}{2} - y \right)$

Distance of the C.G. of the shaded area from neutral axis is given as

$$\begin{aligned}\bar{y} &= y + \frac{1}{2} \left( \frac{D}{2} - y \right) \\ &= y + \frac{D}{4} - \frac{y}{2} \\ &= \frac{D}{4} + \frac{y}{2} = \frac{1}{2} \left( \frac{D}{2} + y \right)\end{aligned}$$

Hence shear stress in the flange becomes,

$$\tau = \frac{F \times A\bar{y}}{I \times B} \quad (\because \text{Here width} = B)$$

$$\begin{aligned}\tau &= \frac{F \times B \left( \frac{D}{2} - y \right) \times \frac{1}{2} \left( \frac{D}{2} + y \right)}{I \times B} \\ &= \frac{F}{2I} \left[ \left( \frac{D}{2} \right)^2 - y^2 \right] \\ &= \frac{F}{2I} \left( \frac{D^2}{2} - y^2 \right) \quad \dots(8.8)\end{aligned}$$

Hence, the variation of shear stress ( $\tau$ ) with respect to  $y$  in the flange is parabolic. It is also clear from equation (8.8) that with the increase of  $y$ , shear stress decreases.

(a) For the upper edge of the flange,

$$y = \frac{D}{2}$$

$$\text{Hence shear stress, } \tau = \frac{F}{2I} \left[ \frac{D^2}{4} - \left( \frac{D}{2} \right)^2 \right] = 0.$$

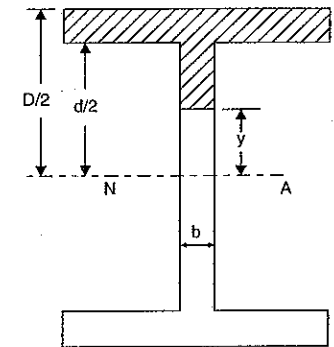

Fig. 8.8 (c)

(b) For the lower edge of the flange,

$$y = \frac{d}{2}$$

Hence

$$\begin{aligned} \tau &= \frac{F}{2I} \left[ \frac{D^2}{4} - \left( \frac{d}{2} \right)^2 \right] = \frac{F}{2I} \left( \frac{D^2}{4} - \frac{d^2}{4} \right) \\ &= \frac{F}{8I} (D^2 - d^2) \end{aligned} \quad \dots(8.9)$$

(ii) Shear stress distribution in the web

Consider a section at a distance  $y$  in the web from the N.A. as shown in Fig. 8.9.

Width of the section =  $b$ .

Here  $A\bar{y}$  is made up of two parts i.e., moment of the flange area about N.A. plus moment of the shaded area of the web about the N.A.

$$\begin{aligned} \therefore A\bar{y} &= \text{Moment of the flange area about N.A.} \\ &\quad + \text{moment of the shaded area of} \\ &\quad \text{web about N.A.} \\ &= B \left( \frac{D}{2} - \frac{d}{2} \right) \times \frac{1}{2} \left( \frac{D}{2} + \frac{d}{2} \right) + b \left( \frac{d}{2} - y \right) \times \frac{1}{2} \left( \frac{d}{2} + y \right) \\ &= \frac{B}{8} (D^2 - d^2) + \frac{b}{2} \left( \frac{d^2}{4} - y^2 \right) \end{aligned}$$

Hence the shear stress in the web becomes as

$$\tau = \frac{F \times A\bar{y}}{I \times b} = \frac{F}{I \times b} \times \left[ \frac{B}{8} (D^2 - d^2) + \frac{b}{2} \left( \frac{d^2}{4} - y^2 \right) \right] \quad \dots(8.10)$$

From equation (8.10), it is clear that variation of  $\tau$  with respect to  $y$  is parabolic. Also with the increase of  $y$ ,  $\tau$  decreases.

At the neutral axis,  $y = 0$  and hence shear stress is maximum.

$$\begin{aligned} \therefore \tau_{max} &= \frac{F}{I \times b} \left[ \frac{B}{8} (D^2 - d^2) + \frac{b}{2} \times \frac{d^2}{4} \right] \\ &= \frac{F}{I \times b} \left[ \frac{B(D^2 - d^2)}{8} + \frac{bd^2}{8} \right] \end{aligned} \quad \dots(8.11)$$

At the junction of top of the web and bottom of flange,

$$y = \frac{d}{2}$$

Hence shear stress is given by,

$$\begin{aligned} \tau &= \frac{F}{I \times b} \left[ \frac{B}{8} (D^2 - d^2) + \frac{b}{2} \left( \frac{d^2}{4} - \left( \frac{d}{2} \right)^2 \right) \right] \\ &= \frac{F \times B \times (D^2 - d^2)}{8I \times b} \end{aligned} \quad \dots(8.12)$$

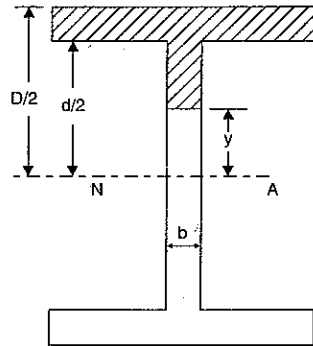

Fig. 8.9

The shear stress distribution for the web and flange is shown in Fig. 8.8 (b). The shear stress at the junction of the flange and the web changes abruptly. The equation (8.9) gives the stress at the junction of the flange and the web when stress distribution is considered in the flange. But equation (8.12) gives the stress at the junction when stress distribution is considered in the web. From these two equations it is clear that the stress at the junction changes abruptly from  $\frac{F}{8I} (D^2 - d^2)$  to  $\frac{B}{b} \times \frac{F}{8I} (D^2 - d^2)$ .

**Problem 8.7.** An I-section beam 350 mm × 150 mm has a web thickness of 10 mm and a flange thickness of 20 mm. If the shear force acting on the section is 40 kN, find the maximum shear stress developed in the I-section.

**Sol.** Given :

Overall depth,  $D = 350$  mm

Overall width,  $B = 150$  mm

Web thickness,  $b = 10$  mm

Flange thickness,  $= 20$  mm

$\therefore$  Depth of web,  $d = 350 - (2 \times 20) = 310$  mm

Shear force on the section,  $F = 40$  kN = 40,000 N.

Moment of inertia of the section about neutral axis,

$$\begin{aligned} I &= \frac{150 \times 350^3}{12} - \frac{140 \times 310^3}{12} \text{ mm}^4 \\ &= 535937500 - 347561666.6 \\ &= 188375833.4 \text{ mm}^4. \end{aligned}$$

Maximum shear stress is given by equation (8.11)

$$\begin{aligned} \therefore \tau_{max} &= \frac{F}{I \times b} \left[ \frac{B(D^2 - d^2)}{8} + \frac{bd^2}{8} \right] \\ &= \frac{40000}{188375833.4 \times 10} \left[ \frac{150(350^2 - 310^2)}{8} + \frac{10 \times 310^2}{8} \right] \\ &= 0.000021234 \left[ \frac{150}{8} (122500 - 96100) + 120125 \right] \\ &= 13.06 \text{ N/mm}^2. \text{ Ans.} \end{aligned}$$

**Alternate Method**

The maximum shear stress developed in the I-section will be at the neutral axis. This shear stress is given by,

$$\tau_{max} = \frac{F \times A \times \bar{y}}{I \times b}$$

where  $F = 40,000$  N

$A \times \bar{y}$  = Moment of the area above the neutral axis about the neutral axis

= Area of flange × Distance of C.G. of the area of flange from neutral axis + Area of web above neutral axis × Distance of the C.G. of this area from neutral axis

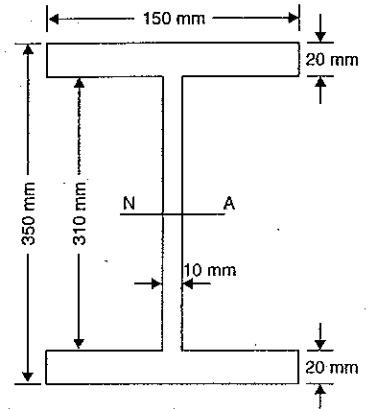

Fig. 8.10

$$\begin{aligned}
 &= (150 \times 20) \times \left( \frac{310}{2} + \frac{20}{2} \right) + \left( \frac{310}{2} \times 10 \right) \times \left( \frac{310}{2} \times \frac{1}{2} \right) \\
 &= 3000 \times 165 + 1550 \times 77.5 \\
 &= 495000 + 120125 = 615125 \text{ mm}^3
 \end{aligned}$$

$I$  = Moment of inertia of the whole section about neutral axis

$$= 188375833.4 \text{ mm}^4 \text{ (Already Calculated)}$$

$b$  = Width of the web at neutral axis

$$= 10 \text{ mm}$$

$$\therefore \tau_{\max} = \frac{40,000 \times 615125}{188375833.4 \times 10} = 13.06 \text{ N/mm}^2. \text{ Ans.}$$

**Problem 8.8.** For the problem 8.7, sketch the shear stress distribution across the section. Also calculate the total shear force carried by the web.

**Sol.** Given :

From problem 8.7, we have

$$B = 150 \text{ mm}; \quad D = 350 \text{ mm}$$

$$d = 310 \text{ mm}; \quad b = 10 \text{ mm}$$

$$F = 40000 \text{ N}; \quad I = 188.375 \times 10^6 \text{ mm}^4$$

$$\tau_{\max} = 13.06 \text{ N/mm}^2.$$

*Shear stress distribution in the flange*

The shear stress at the upper edge of the flange is zero.

Actually shear stress distribution in the flange is given by equation (8.8) as

$$\tau = \frac{F}{2I} \left( \frac{D^2}{4} - y^2 \right) \quad \dots(i)$$

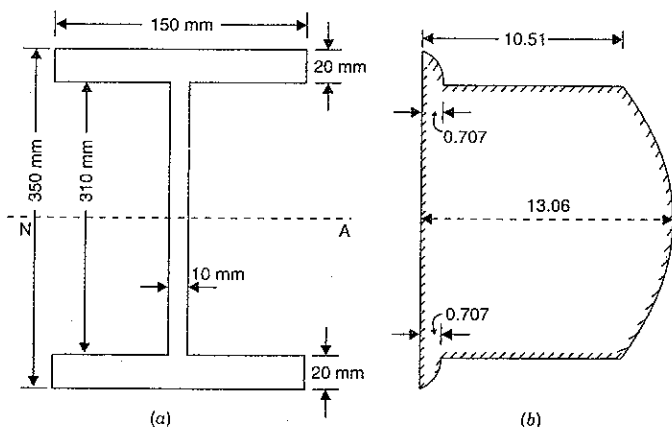

Fig. 8.11

For the upper edge of the flange,

$$y = \frac{D}{2}$$

$$\therefore \tau = \frac{F}{2I} \left( \frac{D^2}{4} - \left( \frac{D}{2} \right)^2 \right) = \frac{F}{2I} \left( \frac{D^2}{4} - \frac{D^2}{4} \right) = 0$$

For the lower edge of the upper flange (i.e.,) at the joint of web and flange,

$$y = \frac{d}{2}$$

$\therefore$  Substituting this value in equation (i), we get

$$\begin{aligned}
 \tau &= \frac{F}{2I} \left[ \frac{D^2}{4} - \left( \frac{d}{2} \right)^2 \right] = \frac{F}{2I} \left( \frac{D^2}{4} - \frac{d^2}{4} \right) \\
 &= \frac{F}{8I} (D^2 - d^2) = \frac{40000}{8 \times 188.375 \times 10^6} (350^2 - 310^2) \\
 &= 0.7007 \text{ N/mm}^2.
 \end{aligned}$$

*Shear stress distribution in the web*

The shear stress is maximum at N.A. and it is given by,

$$\tau_{\max} = 13.06 \text{ N/mm}^2 \quad \text{(calculate in problem 8.7)}$$

The shear stress at the junction of web and flange is given by equation (8.12) as

$$\begin{aligned}
 \tau &= \frac{F \times B}{8I \times b} (D^2 - d^2) \\
 &= \frac{40000 \times 150}{8 \times 188.375 \times 10^6 \times 10} (350^2 - 310^2) = 10.51 \text{ N/mm}^2
 \end{aligned}$$

(The shear stress at the junction can also be obtained as equal to

$$\frac{B}{b} \times 0.7007 = \frac{150}{10} \times 0.7007 = 10.51 \text{ N/mm}^2)$$

Now shear stress distribution which is symmetrical about N.A., can be plotted as shown in Fig. 8.11 (b). The shear stress for web and flange are parabolic. The shear stress at the junction suddenly changes from 0.707 to 10.51 N/mm<sup>2</sup>.

*Total Shear force carried by the web*

Total shear force carried by the web will be equal to the total shear force carried by the I-section minus the total shear force carried by the two flanges.

$\therefore$  Total shear force carried by the web

$$= \text{Total shear force carried by I-section} - 2 \times \text{shear force carried by one flange} \quad \dots(ii)$$

$$= 40,000 - 2 \times \text{Shear force carried by one flange}$$

To find the shear force carried by one flange, first calculate the shear stress in the flange at a distance 'y' from neutral axis. Now consider an elemental strip of flange of thickness 'dy'. Then area of strip will be width of the flange  $\times$  thickness of strip i.e.,  $dA = 150 \times dy$ . Now the shear force carried by the elemental strip

$$= \text{Shear stress at a distance } y \text{ in the flange} \times \text{Area of the strip}$$

$$= \tau \times 150 \times dy$$

Total shear force carried by the flange will be obtained by integrating the above equation from  $\frac{310}{2}$  to  $\frac{350}{2}$  (i.e., from 155 to 175).

∴ Total shear force carried by one flange

$$= \int_{155}^{175} \tau \times 150 \times dy \quad \dots(iii)$$

The value of ' $\tau$ ' (i.e., shear stress) in the flange at a distance  $y$  from neutral axis is given by

$$\tau = \frac{F \times A \times \bar{y}}{I \times b}$$

where  $F = 40,000$

$A\bar{y}$  = Moment of area of the flange above  $y$ , about neutral axis

[i.e., shaded area of Fig. 8.8 (c) on page 357]

$$= B \left( \frac{D}{2} - y \right) \times \frac{1}{2} \left( \frac{D}{2} + y \right)$$

$$= 150 \left( \frac{350}{2} - y \right) \times \frac{1}{2} \left( \frac{350}{2} + y \right)$$

(∵ Here  $B = 150, D = 350$ )

$$= 150 (175 - y) \times \frac{1}{2} (175 + y)$$

$$= 75 (175^2 - y^2) = 75 (30625 - y^2)$$

$I$  = Moment of inertia of the whole section about neutral axis

$$= 188.375 \times 10^6 \text{ mm}^4$$

(Already calculated)

$b$  = Width of flange

$$= 150 \text{ mm.}$$

Substituting the above values, we get

$$\tau = \frac{40,000 \times 75 (30625 - y^2)}{188.375 \times 10^6 \times 150} = 0.000106 (30625 - y^2)$$

Substituting this value of  $\tau$  in equation (iii), we get

Total shear force carried by one flange

$$= \int_{155}^{175} 0.000106 (30625 - y^2) \times 150 \times dy$$

$$= 0.000106 \times 150 \int_{155}^{175} (30625 - y^2) dy$$

$$= 0.0159 \left[ 30625y - \frac{y^3}{3} \right]_{155}^{175}$$

$$= 0.0159 \left[ 30625 (175 - 155) - \frac{1}{3} (175^3 - 155^3) \right]$$

$$= 0.0159 \left[ 612500 - \frac{1}{3} (5359375 - 3723875) \right]$$

$$= 0.0159 [612500 - 545166.66]$$

$$= 1070.61 \text{ N}$$

Substituting this value in equation (ii), we get

Total shear force carried by web

$$= 40,000 - 2 \times 1070.61$$

$$= 37858.78 \text{ N} = 37.858 \text{ kN. Ans.}$$

**8.3.4. T-Section.** The shear stress distribution over a T-section is obtained in the same manner as over an I-section. But in this case the position of neutral axis (i.e., position of C.G.) is to be obtained first, as the section is not symmetrical about  $x-x$  axis. The shear stress distribution diagram will also not be symmetrical.

**Problem 8.9.** The shear force acting on a section of a beam is 50 kN. The section of the beam is of T-shaped of dimensions 100 mm × 100 mm × 20 mm as shown in Fig. 8.12. The moment of inertia about the horizontal neutral axis is  $314.221 \times 10^4 \text{ mm}^4$ . Calculate the shear stress at the neutral axis and at the junction of the web and the flange.

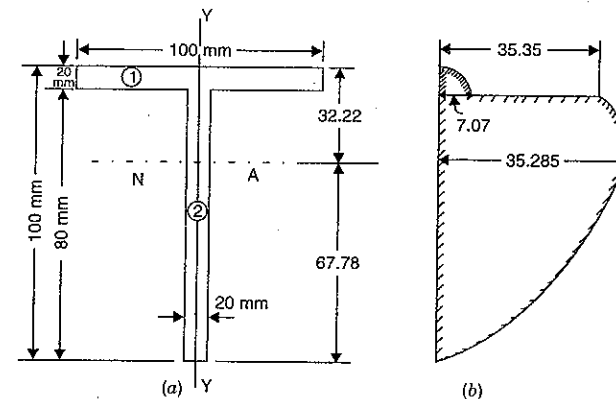

Fig. 8.12

**Sol. Given :**

Shear force,  $F = 50 \text{ kN} = 50000 \text{ N}$

Moment of inertia about N.A.,

$$I = 314.221 \times 10^4 \text{ mm}^4.$$

First calculate the position of neutral axis. This can be obtained if we know the position of C.G. of given T-section. The given section is symmetrical about the axis  $Y-Y$  and hence the C.G. of the section will lie on  $Y-Y$  axis.

Let  $y^*$  = Distance of the C.G. of the section from the top of the flange.

$$\text{Then } y^* = \frac{A_1 y_1 + A_2 y_2}{(A_1 + A_2)}$$

$$\begin{aligned}
 &= \frac{(100 \times 20) \times 10 + (20 \times 80) \times \left(20 + \frac{80}{2}\right)}{(100 \times 10) + (10 \times 90)} \\
 &= \frac{20000 + 96000}{2000 + 1600} = 32.22.
 \end{aligned}$$

Hence, neutral axis will be at a distance of 32.22 mm from the top of the flange as shown in Fig. 8.12 (a).

#### Shear stress distribution in the flange

Now the shear stress at the top edge of the flange, and bottom of the web is zero.

Shear stress in the flange just at the junction of the flange and web is given by,

$$\tau = \frac{F \times A\bar{y}}{I \times b}$$

where  $A = 100 \times 20 = 2000 \text{ mm}^2$   
 $\bar{y}$  = Distance of C.G. of the area of flange from N.A.

$$= 32.22 - \frac{20}{2} = 22.22 \text{ mm}$$

$b$  = Width of flange = 100 mm

$$\tau = \frac{50000 \times 2000 \times 22.22}{314.221 \times 10^4 \times 100} = 7.07 \text{ N/mm}^2.$$

#### Shear stress distribution in the web

The shear stress in the web just at the junction of the web and flange will suddenly increase from  $7.07 \text{ N/mm}^2$  to  $7.07 \times \frac{100}{20} = 35.35 \text{ N/mm}^2$ . The shear stress will be maximum at N.A. Hence shear stress at the N.A. is given by

$$\tau = \frac{F \times A\bar{y}}{I \times b}$$

where  $A\bar{y}$  = Moment of the above N.A. about N.A.  
 = Moment of area of flange about N.A. + Moment of area of web about N.A.

$$= 20 \times 100 \times (32.22 - 10) + 20 \times (32.22 - 10) \times \frac{22.22}{2}$$

$$= 44440 + 4937.28 = 49377.284 \text{ mm}^2$$

$b = 20 \text{ mm}$

$$\tau = \frac{50000 \times 49377.284}{314.221 \times 10^4 \times 20} = 39.285 \text{ N/mm}^2$$

Now the shear stress distribution diagram can be drawn as shown in Fig. 8.12 (b).

**8.3.5. Miscellaneous Sections.** The shear stress distribution over miscellaneous sections is obtained in the same manner as over a T-section. Here also the position of neutral axis is obtained first.

**Problem 8.10.** The shear force acting on a beam at an I-section with unequal flanges is 50 kN. The section is shown in Fig. 8.13. The moment of inertia of the section about N.A. is  $2.849 \times 10^4$ . Calculate the shear stress at the N.A. and also draw the shear stress distribution over the depth of the section.

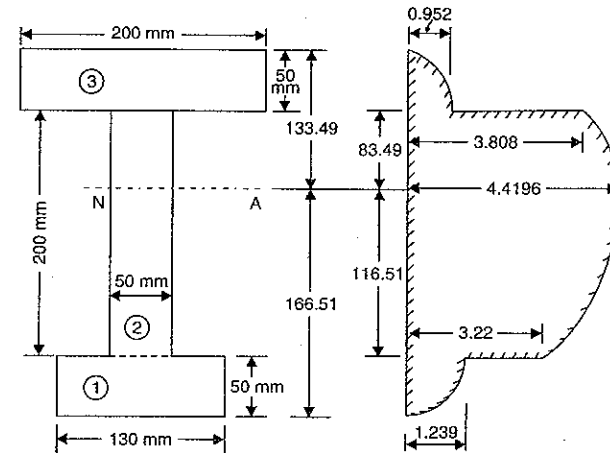

Fig. 8.13

Sol. Given :

Shear force,  $F = 50 \text{ kN} = 50,000 \text{ N}$

Moment of inertia about N.A.,

$$I = 2.849 \times 10^8 \text{ mm}^4.$$

Let us first calculate the position of N.A. This is obtained if we know the position of the C.G. of the given I-section. Let  $y^*$  is the distance of the C.G. from the bottom face. Then

$$y^* = \frac{A_1 y_1 + A_2 y_2 + A_3 y_3}{(A_1 + A_2 + A_3)}$$

where  $A_1$  = Area of bottom flange

$$= 130 \times 50 = 6500 \text{ mm}^2$$

$A_2$  = Area of web =  $200 \times 50 = 10000 \text{ mm}^2$

$A_3$  = Area of top flange =  $200 \times 50 = 10000 \text{ mm}^2$

$y_1$  = Distance of C.G. of  $A_1$  from bottom face

$$= \frac{50}{2} = 25 \text{ mm}$$

$y_2$  = Distance of C.G. of  $A_2$  from bottom face

$$= 50 + \frac{200}{2} = 150 \text{ mm}$$

$y_3$  = Distance of C.G. of  $A_3$  from bottom face

$$= 50 + 200 + \frac{50}{2} = 275 \text{ mm}$$

$$\therefore y^* = \frac{6500 \times 25 \times 10000 \times 150 + 10000 \times 275}{6500 + 10000 + 10000} = 166.51 \text{ mm}$$

Hence N.A. is at a distance of 166.51 mm from the bottom face (or  $300 - 166.51 = 133.49$  mm from upper top fibre).

#### Shear stress distribution

(i) Shear stress at the extreme edges of the flanges is zero.

(ii) The shear stress in the upper flange just at the junction of upper flange and web is given by,

$$\tau = \frac{F \times A\bar{y}}{I \times b}$$

where  $A\bar{y}$  = Moment of the area of the upper flange about N.A.  
 = Area of upper flange  $\times$  Distance of the C.G. of upper flange from N.A.  
 =  $(200 \times 50) \times (133.49 - 25) = 1084900$   
 $b$  = Width of upper flange = 200 mm

$$\therefore \tau = \frac{50000 \times 1084900}{2.849 \times 10^8 \times 200} = 0.9520 \text{ N/mm}^2.$$

(iii) The shear stress in the web just at the junction of the web and upper flange will suddenly increase from 0.952 to  $0.952 \times \frac{200}{50} = 3.808 \text{ N/mm}^2$ .

(iv) The shear stress will be maximum at the N.A. This is given by

$$\tau_{max} = \frac{F \times A\bar{y}}{I \times b}$$

where  $A\bar{y}$  = Moment of total area (about N.A.) about N.A.  
 = Moment of area of upper flange about N.A. + Moment of area of web about N.A.  
 =  $200 \times 50 \times (133.49 - 25) + (133.49 - 50) \times 50 \times \frac{(133.49 - 50)}{2}$   
 =  $1084900 + 174264.5 = 1259164.5$

and  $b = 50 \text{ mm}$

$$\therefore \tau_{max} = \frac{50000 \times 1259164.5}{2.849 \times 10^8 \times 50} = 4.4196 \text{ N/mm}^2.$$

(v) The shear stress in the lower flange just at the junction of the lower flange and the web is given by

$$\tau = \frac{F \times A\bar{y}}{I \times b}$$

where  $A\bar{y}$  = Moment of the area of the lower flange about N.A.  
 =  $130 \times 50 \times (166.51 - 25) = 918125$   
 $b$  = Width of lower flange = 130 mm

$$\therefore \tau = \frac{50000 \times 918125}{2.849 \times 10^8 \times 130} = 1.239 \text{ N/mm}^2.$$

(vi) The shear stress in the web just at the junction of the web and lower flange will suddenly increase from 1.239 to  $\frac{1.239 \times 130}{50} = 3.22 \text{ N/mm}^2$ .

The shear stress diagram is shown in Fig. 8.13 (b).

**Problem 8.11.** The shear force acting on a beam at a section is  $F$ . The section of the beam is triangular base  $b$  and of an altitude  $h$ . The beam is placed with its base horizontal. Find the maximum shear stress and the shear stress at the N.A.

**Sol.** Given :

$$\text{Base} = b$$

$$\text{Altitude} = h$$

The N.A. of the triangle  $ABC$  will lie at the C.G. of the triangle. But the C.G. of the triangle will be at a distance of  $\frac{2h}{3}$  from the top.

$\therefore$  Neutral axis will be at a distance of  $\frac{2h}{3}$  from the top.

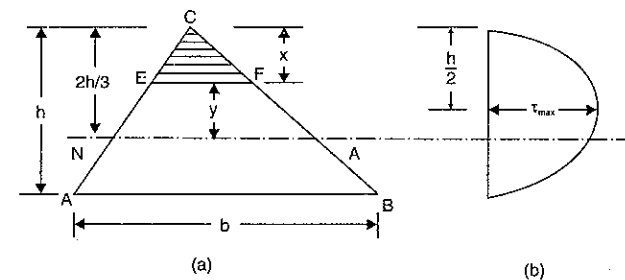

Fig. 8.14

Consider a level  $EF$  at a distance  $y$  from the N.A. The shear stress at this level is given by,

$$\tau = \frac{F \times A\bar{y}}{I \times b} \quad \dots(i)$$

where  $A\bar{y}$  = Moment of the shaded area about the neutral axis  
 = Area of triangle  $CEF$   $\times$  Distance of C.G. of triangle  $CEF$  from N.A.

$$= \left( \frac{1}{2} \times EF \times x \right) \times \left( \frac{2h}{3} - \frac{2x}{3} \right)$$

$$= \left( \frac{1}{2} \times \frac{bx}{h} \times x \right) \times \frac{2}{3} (h - x)$$

( $\because$  As triangles  $CEF$  and  $CAB$  are similar.

$$\text{Hence } \frac{EF}{AB} = \frac{x}{h} \text{ or } EF = \frac{x}{h} \times AB = \frac{x \times b}{h}$$

$$= \frac{1}{2} \times \frac{bx^2}{h} \times \frac{2}{3} (h - x)$$

$$= \frac{1}{3} \times \frac{bx^2}{h} \times (h - x)$$

$I$  = Moment of inertia of the whole triangular section  $CAB$  about N.A.

$b$  = Actual width at the level  $EF$

$$= EF = \frac{x \times b}{h}$$

Substituting these values in equation (i), we get

$$\begin{aligned} \tau &= \frac{F \times \frac{1}{3} \cdot \frac{bx^2}{h} \cdot (h-x)}{I \times \frac{x \times b}{h}} = \frac{1}{3} \cdot \frac{F \cdot x(h-x)}{I} \\ &= \frac{F}{3I} (xh - x^2) \end{aligned} \quad \dots(ii)$$

From equation (ii), it is clear that variation of  $\tau$  with respect to  $x$  is parabolic. At the top,  $x = 0$  and hence  $\tau$  is also zero. At the bottom  $x = h$  and  $\tau$  is also zero.

At the N.A.,  $x = \frac{2h}{3}$ , and hence the shear at the N.A. becomes as,

$$\begin{aligned} \tau &= \frac{F}{3I} \left[ \frac{2h}{3} \times h - \left( \frac{2h}{3} \right)^2 \right] \\ &= \frac{F}{3I} \left[ \frac{2h^2}{3} - \frac{4h^2}{9} \right] = \frac{F}{3I} \times \frac{(6h^2 - 4h^2)}{9} = \frac{F}{3I} \times \frac{2h^2}{9} = \frac{2}{27} \times \frac{Fh^2}{I} \end{aligned}$$

But

$$\begin{aligned} I &= \frac{bh^3}{36} \\ \tau &= \frac{2}{27} \times \frac{Fh^2}{\left( \frac{bh^3}{36} \right)} = \frac{2}{27} \times \frac{36 \times Fh^2}{bh^3} \\ &= \frac{8}{3} \cdot \frac{F}{bh} \end{aligned} \quad \dots(8.13)$$

**Maximum shear stress**

The shear stress of any depth  $x$  from the top is given by equation (ii). The maximum shear stress will be obtained by differentiating equation (ii) with respect to  $x$  and equating to zero.

$$\frac{d}{dx} \left[ \frac{F}{3I} (xh - x^2) \right] = 0$$

$$\begin{aligned} \text{or} \quad & \frac{F}{3I} (h - 2x) = 0 \\ \text{or} \quad & h - 2x = 0 \quad (\because F \text{ and } I \text{ are constants and cannot be zero}) \\ \text{or} \quad & x = \frac{h}{2} \end{aligned}$$

Now substituting this value of  $x$  in equation (ii), we get

$$\tau_{max} = \frac{F}{3I} \left[ \frac{h}{2} \times h - \left( \frac{h}{2} \right)^2 \right]$$

$$\begin{aligned} &= \frac{F}{3I} \left[ \frac{h^2}{2} - \frac{h^2}{4} \right] = \frac{F}{3I} \times \frac{h^2}{4} = \frac{Fh^2}{12I} \\ &= \frac{Fh^3}{12 \times \frac{bh^3}{36}} \quad \left( \because I = \frac{bh^3}{12} \right) \\ &= \frac{36}{12} \times \frac{Fh^2}{bh} \\ &= \frac{3F}{bh} \end{aligned} \quad \dots(8.14)$$

Now draw the shear stress diagram as shown in Fig. 8.14 (b).

**Note.** In the above case, the shear stress is not maximum at the N.A., but it is maximum at a depth of  $h/2$  from the top. In all other cases, the shear stress was maximum at the N.A.

**Problem 8.12.** A beam of triangular cross-section is subjected to a shear force of 50 kN. The base width of the section is 250 mm and height 200 mm. The beam is placed with its base horizontal. Find the maximum shear stress and the shear stress at the N.A.

**Sol. Given :**

- Shear force,  $F = 50 \text{ kN} = 50000 \text{ N}$
- Base width,  $b = 250 \text{ mm}$
- Height,  $h = 200 \text{ mm}$

Maximum shear stress is given by equation (8.14).

$$\therefore \tau_{max} = \frac{3F}{bh} = \frac{3 \times 50000}{250 \times 200} = 3 \text{ N/mm}^2. \text{ Ans.}$$

Shear stress at N.A. is given by equation (8.13).

$$\therefore \tau = \frac{8F}{3bh} = \frac{8 \times 50000}{3 \times 250 \times 200} = 2.67 \text{ N/mm}^2. \text{ Ans.}$$

**Problem 8.13.** A beam of square section is used as a beam with one diagonal horizontal. The beam is subjected to a shear force  $F$ , at a section. Find the maximum shear in the cross-section of the beam and draw the shear distribution diagram for the section.

**Sol. Given :**

Fig. 8.15 shows a square beam  $ABCD$ , having diagonal  $AC$  horizontal.

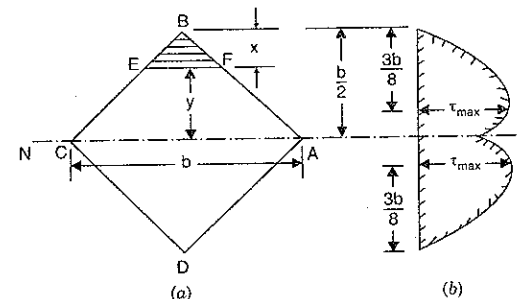

Fig. 8.15



Let  $b$  = Length of diagonal  $AC$ . This is also length of diagonal  $BD$ .

The N.A. of the beam shown in Fig. 8.15 (a), passes through diagonal  $AC$ .

Consider a level  $EF$  at a distance  $y$  from the N.A. The shear stress at this level is given

by,

$$\tau = \frac{F \times A\bar{y}}{I \times b} \quad \dots(i)$$

where  $A\bar{y}$  = Moment of the shaded area about N.A.

= Area of triangle  $BEF$   $\times$  Distance of C.G. of triangle  $BEF$  from N.A.

$$= \left(\frac{1}{2} \times EF \times x\right) \left(\frac{b}{2} - \frac{2}{3}x\right)$$

$$= \left(\frac{1}{2} \times 2x \times x\right) \left(\frac{b}{2} - \frac{2}{3}x\right) \quad \left(\because \frac{EF}{CA} = \frac{x}{(b/2)}, \therefore EF = \frac{x}{(b/2)} \times b = 2x\right)$$

$$= x^2 \left(\frac{b}{2} - \frac{2x}{3}\right)$$

$I$  = Moment of inertia of the whole section about N.A.

$$= 2 \times \frac{b \times \left(\frac{b}{2}\right)^3}{12} = \frac{b^4}{48}$$

and  $b$  = Actual width at the level  $EF = 2x$

Substituting these values in equation (i), we get

$$\begin{aligned} \tau &= \frac{F \times x^2 \left(\frac{b}{2} - \frac{2x}{3}\right)}{\left(\frac{b^4}{48}\right) \times 2x} = \frac{F \times 24x \left[\frac{3b - 4x}{6}\right]}{b^4} \\ &= \frac{4F}{b^4} x (3b - 4x) \quad \dots(ii) \end{aligned}$$

At the top,  $x = 0$  hence  $\tau = 0$

$$\begin{aligned} \text{At the N.A., } x &= \frac{b}{2} \text{ hence } \tau = \frac{4F}{b^2} \cdot \frac{b}{2} \left(3b - 4 \times \frac{b}{2}\right) \\ &= \frac{4F}{b^4} \cdot \frac{b}{2} \cdot b = \frac{2F}{b^2} \end{aligned}$$

#### Maximum shear stress

Maximum shear stress will be obtained by differentiating equation (ii) with respect to  $x$  and equating to zero.

$$\therefore \frac{d}{dx} \left[ \frac{4F}{b^4} (3bx - 4x^2) \right] = 0$$

or

$$\frac{4F}{b^4} (3b - 8x) = 0$$

or

$$3b - 8x = 0 \quad \left(\because \frac{4F}{b^4} \text{ cannot be zero}\right)$$

or

$$x = \frac{3b}{8}$$

Substituting this value of  $x$  in equation (ii), we get maximum shear stress.

$$\therefore \tau_{max} = \frac{4F}{b^4} \times \frac{3b}{8} \left(3b - 4 \times \frac{3b}{8}\right) = \frac{4F}{b^4} \times \frac{3b}{8} \times \frac{3b}{2} = \frac{9}{4} \times \frac{F}{b^2}$$

The shear stress distribution is shown in Fig. 8.15 (b).

**Problem 8.14.** Fig. 8.16 shows a section, which is subjected to a shear force of 100 kN. Determine the shear stresses at A, B, C and D. Sketch the shear stress distribution also.

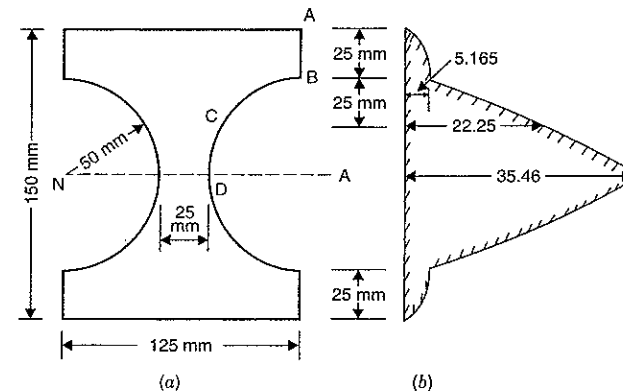

Fig.

**Sol. Given :**

Shear force,  $F = 100 \text{ kN} = 100000 \text{ N}$ .

The neutral axis will be at a distance of  $62.5 \text{ mm}$  from the top, as the given section is symmetrical about  $X-X$  and  $Y-Y$  axis.

Moment of inertia of the given section about N.A. is given by,

$$I = \text{M.O.I. of rectangle } 125 \times 150 \text{ about N.A.}$$

$$- \text{M.O.I. two semi-circle (or one circular hole) about N.A.}$$

$$= \frac{125 \times 150^3}{12} - \frac{\pi}{64} \times 100^4 \text{ mm}^4 = 3.025 \times 10^7 \text{ mm}^4$$

The shear stress is given by,

$$\tau = \frac{F \times A\bar{y}}{I \times b}$$

At A,  $A\bar{y} = 0$  and hence  $\tau = 0$

At B,  $A\bar{y}$  = Moment of area  $(125 \times 25)$  about N.A.

$$= (125 \times 25) \times \left(50 + \frac{25}{2}\right) \quad \left(\because A = 125 \times 25 \text{ and } \bar{y} = 50 + \frac{25}{2}\right)$$

$$= 125 \times 25 \times 62.5 = 1.953 \times 10^5 \text{ mm}^3$$

$$b = 125 \text{ mm}$$

$$\therefore \tau = \frac{100000 \times 1.9531 \times 10^5}{3.025 \times 10^7 \times 125} = 5.165 \text{ N/mm}^2. \text{ Ans.}$$

At C,  $A\bar{y}$  = Moment of area above an horizontal line passing through C.C., about N.A.  
 = Moment of area of rectangle  $125 \times 50$  about N.A.  
 - Moment of area of circular portion between C and B about N.A.

$$= (125 \times 50) \times \left(25 + \frac{50}{2}\right) - \int_{y=25}^{y=50} 2x \cdot dy \cdot y$$

$$= 3.125 \times 10^5 - \int_{25}^{50} 2 \times \sqrt{2500 - y^2} \times y \times dy \quad \left(\because x = \sqrt{R^2 - y^2}\right)$$

$$= 3.125 \times 10^5 - \int_{25}^{50} -\sqrt{2500 - y^2} (-2y) \times dy$$

$$= 3.125 \times 10^5 + \left[\frac{(2500 - y^2)^{3/2}}{3/2}\right]_{25}^{50}$$

$$= 3.125 \times 10^5 + \frac{2}{3} [(2500 - 50^2)^{3/2} - (2500 - 25^2)^{3/2}]$$

$$= 3.125 \times 10^5 + \frac{2}{3} [0 - (2500 - 625)^{3/2}]$$

$$= 3.125 \times 10^5 + \frac{2}{3} (-81189)$$

$$= 3.125 \times 10^5 - 54126 = 258374 \text{ mm}^3$$

$b$  = Width of beam at C (i.e., length C-C)  
 = Width of complete section - 2  
 × Width of circular portion at C  
 (i.e., length EC)

$$= 125 - 2 \times \sqrt{R^2 - 25^2}$$

$$= 125 - 2 \times \sqrt{50^2 - 25^2}$$

$$= 125 - 86.6$$

$$= 38.4 \text{ mm}$$

$$\therefore \tau = \frac{100000 \times 258374}{3.025 \times 10^7 \times 38.4} = 22.25 \text{ N/mm}^2. \text{ Ans.}$$

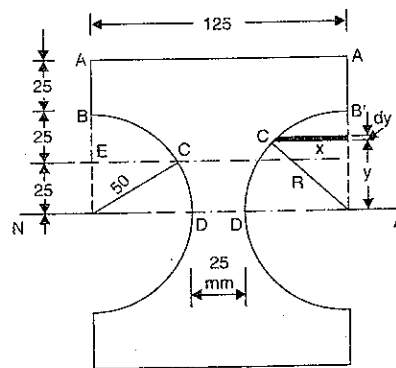

Fig. 8.17

At D,  $A\bar{y}$  = Moment of area above N.A., about N.A.  
 = Moment of area of rectangle  $125 \times 75$  about N.A.  
 - Moment of area of circular portion between D and B about N.A.

$$= 125 \times 75 \times \frac{75}{2} - \int_{y=50}^{y=75} 2x \cdot dy \cdot y$$

$$= 351500 - \int_0^{50} 2 \times \sqrt{2500 - y^2} \times y \times dy \quad \left(\because x = \sqrt{2500 - y^2}\right)$$

$$= 351500 - \int_0^{50} -\sqrt{2500 - y^2} (-2y) dy$$

$$= 351500 + \left[\frac{(2500 - y^2)^{3/2}}{3/2}\right]_0^{50}$$

$$= 351500 + \frac{2}{3} [(2500 - 50^2)^{3/2} - (2500 - 0)^{3/2}]$$

$$= 351500 + \frac{2}{3} [0 - 125000]$$

$$= 351500 - 83333.33 \text{ mm}^3$$

$$= 268166.67 \text{ mm}^3$$

$b$  = Width of beam at D (i.e., length D-D)  
 = 25 mm

$$\therefore \tau = \frac{100000 \times 268166.67}{3.025 \times 10^7 \times 25} = 35.46 \text{ N/mm}^2. \text{ Ans.}$$

The variation of shear stress is shown in Fig. 8.16 (b).

### HIGHLIGHTS

1. The stresses produced in a beam, which is subjected to shear force is known as shear stresses.
2. The shear stress at a fibre in a section of a beam is given by,

$$\tau = \frac{F \times A\bar{y}}{I \times b}$$

where  $F$  = Shear force acting at the given section.  
 $A$  = Area of the section above the fibre.  
 $\bar{y}$  = Distance of the C.G. of the area  $A$  from the N.A.  
 $I$  = Moment of inertia of whole section about N.A.  
 $b$  = Actual width at the fibre.

3. The shear stress distribution across a rectangular section is parabolic and is given by,

$$\tau = \frac{F}{2I} \left(\frac{d^2}{4} - y^2\right)$$

where  $d$  = Depth of the beam  
 $y$  = Distance of the fibre from N.A.

4. The maximum shear stress is at the N.A. for a rectangular section and is given by,

$$\tau_{max} = 1.5 \tau_{avg}$$

5. The shear stress distribution across a circular section is parabolic and is given by,

$$\tau = \frac{F}{3I} (R^2 - y^2).$$

6. The shear stress is maximum at the N.A. for a circular section and is given by,

$$\tau_{max} = \frac{4}{3} \times \tau_{avg}.$$

7. The shear stress distribution in I-section is parabolic. But at the junction of web and flange, the shear stress changes abruptly. The shear stress at the junction of the flange and the web changes

from  $\frac{F}{8I} (D^2 - d^2)$  to  $\frac{B}{b} \times \frac{F}{8I} (D^2 - d^2)$  abruptly,

where  $D$  = Overall depth of the section,

$d$  = Depth of web,

$b$  = Thickness of web,

$B$  = Overall width of the section.

8. The shear stress distribution for unsymmetrical sections is obtained after calculating the position of N.A.  
 9. In case of triangular section, the shear stress is not maximum at the N.A. The shear stress is maximum at a height of  $h/2$ .  
 10. The shear stress distribution diagram for a composite section, should be drawn by calculating the shear stress at important points.

### EXERCISE 8

#### (A) Theoretical Questions

1. What do you mean by shear stresses in beams ?
2. Prove that the shear stress at any point (or in a fibre) in the cross-section of a beam which is subjected to a shear force  $F$ , is given by

$$\tau = F \times \frac{A \bar{y}}{b \times I}$$

where  $A$  = Area of the section above the fibre,

$\bar{y}$  = Distance of the C.G. of the area  $A$  from N.A.,

$b$  = Actual width at the fibre, and

$I$  = Moment of inertia of the section about N.A.

3. Show that for a rectangular section of the maximum shear stress is 1.5 times the average stress.
4. Prove that the shear stress distribution in a rectangular section of a beam which is subjected to a shear force  $F$  is given by

$$\tau = \frac{F}{2I} \left( \frac{d^2}{4} - y^2 \right).$$

5. Prove that the maximum shear stress in a circular section of a beam is  $4/3$  times the average shear stress.
6. Derive an expression for the shear stress at any point in a circular section of a beam, which is subjected to a shear force  $F$ .
7. How will you draw the shear stress distribution diagram for composite section ?
8. How will you prove that the shear stress changes abruptly at the junction of the flange and the web of an I-section ?

9. The shear stress is not maximum at the N.A. in case of a triangular section. Prove this statement.
10. Prove that the maximum shear stress in a triangular section of a beam is given by

$$\tau_{max} = \frac{3F}{bh}$$

where  $b$  = Base width, and

$h$  = Height.

11. Show that the ratio of maximum shear stress to mean shear stress in a rectangular cross-section is equal to 1.50 when it is subjected to a transverse shear force  $F$ . Plot the variation of shear stress across the section. *(Bangalore University, March 1989)*
12. Sketch the distribution of shear stress across the depth of the beams of the following cross-sections :  
 (i) T-section, and  
 (ii) Square section with diagonal vertical. *(Bangalore University, March 1989)*

#### (B) Numerical Problems

1. A rectangular beam 100 mm wide and 150 mm deep is subjected to a shear force of 30 kN. Determine : (i) average shear stress and (ii) maximum shear stress. [Ans. 2 N/mm<sup>2</sup> ; 3 N/mm<sup>2</sup>]
2. A rectangular beam 100 mm wide is subjected to a maximum shear force of 100 kN. Find the depth of the beam if the maximum shear stress is 6 N/mm<sup>2</sup>. [Ans. 250 mm]
3. A timber beam of rectangular section is simply supported at the ends and carries a point load at the centre of the beam. The length of the beam is 6 m and depth of beam is 1 m. Determine the maximum bending stress and the maximum shear stress. [Ans. 12 N/mm<sup>2</sup> ; 1 N/mm<sup>2</sup>]
4. A timber beam 100 mm wide and 150 mm deep supports a uniformly distributed load of intensity  $w$  kN/m length over a span of 2 m. If the safe stresses are 28 N/mm<sup>2</sup> in bending and 2 N/mm<sup>2</sup> in shear, calculate the safe intensity of the load which can be supported by the beam. [Ans. 20 kN/m]
5. A circular beam of 105 mm diameter is subjected to a shear force of 5 kN. Calculate : (i) average shear stress, and (ii) maximum shear stress. Also sketch the variation of the shear stress along the depth of the beam. [Ans. (i) 0.577 N/mm<sup>2</sup> (ii) 0.769 N/mm<sup>2</sup>]
6. The maximum shear stress in a beam of circular section of diameter 150 mm, is 5.28 N/mm<sup>2</sup>. Find the shear force to which the beam is subjected. [Ans. 70 kN]
7. A beam of I-section is having overall depth as 500 mm and overall width as 190 mm. The thickness of flanges is 25 mm whereas the thickness of the web is 15 mm. The moment of inertia about N.A. is given as  $6.45 \times 10^8$  mm<sup>4</sup>. If the section carries a shear force of 40 kN, calculate the maximum shear stress. Also sketch the shear stress distribution across the section. [Ans. 62.33 N/mm<sup>2</sup>]
8. An I-section has flanges of width  $b$  and the overall depth is  $2b$ . The flanges and web are of uniform thickness  $t$ . Find the ratio of the maximum shear stress to the average shear stress. [Ans. 2.25]
9. An I-section has the following dimensions :  
 flanges : 150 mm  $\times$  20 mm  
 web : 30 mm  $\times$  10 mm.  
 The maximum shear stress developed in the beam is 16.8 N/mm<sup>2</sup>. Find the shear force to which the beam is subjected. [Ans. 50 kN]
10. A 12 cm by 5 cm I-section is subjected to a shearing force of 10 kN. Calculate the shear stress at the neutral axis and at the top of the web. What percentage of shearing force is carried by the web ? Given  $I = 220 \times 10^4$  mm<sup>4</sup>, area =  $9.4 \times 10^2$  mm<sup>2</sup>, web thickness = 3.5 mm and flange thickness = 5.5 mm. [Ans. 27.2 N/mm<sup>2</sup> ; 20.1 N/mm<sup>2</sup> ; 9.5 kN. i.e., 95% of the total]

11. The shear force acting on a section of a beam is 100 kN. The section of the beam is of T-shaped of dimensions 200 mm × 250 mm × 50 mm. The flange thickness and web thickness are 50 mm. Moment of inertia about the horizontal neutral axis is  $1.134 \times 10^8 \text{ mm}^4$ . Find the shear stress at the neutral axis and at the junction of the web and the flange.  
[Ans. 11.64 N/mm<sup>2</sup>; 2.76 N/mm<sup>2</sup> and 11.04 N/mm<sup>2</sup>]
12. A beam is of T-section, flange 12 cm by 1 cm, web 10 cm by 1 cm. What percentage of the shearing force at any section is carried by the web?  
[Ans. 93.5%]
13. For the section shown in Fig. 8.18, determine the average shearing stresses at A, B, C and D for a shearing force of 20 kN. Draw also the shear stress distribution across the section.  
[Ans. 0; 6.47 N/mm<sup>2</sup>; 27.7 N/mm<sup>2</sup>; 44.4. N/mm<sup>2</sup>]

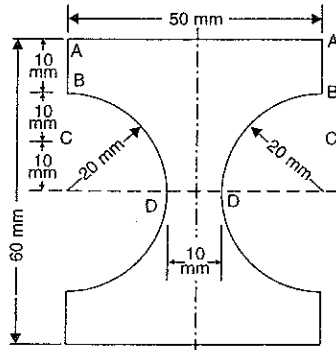

Fig. 8.18

14. A rectangular beam is simply supported at the ends and carries a point load at the centre. Prove that the ratio of span to depth

$$= \frac{\text{Maximum bending stress}}{2 \times \text{Maximum shear stress}}$$

[Hint. Let  $W$  = Point load at centre,  
 $b$  = width, and  $d$  = Depth.

$$\text{Max. Shear force} = \frac{W}{2}, \text{ Max. bending moment} = \frac{WL}{4}$$

$$\therefore \text{Max. bending stress} = \frac{M}{Z} = \frac{\left(\frac{WL}{4}\right)}{\left(\frac{bd^2}{6}\right)} = \frac{WL}{4} \times \frac{6}{bd^2} = \frac{3WL}{2bd^2}$$

$$\text{Max. shear stress} = \frac{3}{2} \times \text{Average shear stress}$$

$$= \frac{3}{2} \times \frac{\text{Max. shear force}}{\text{Area of section}} = \frac{3}{2} \times \frac{W}{2} \times \frac{1}{b \times d} = \frac{3}{4} \times \frac{W}{b \times d}$$

$$\therefore \frac{\text{Max. bending stress}}{2 \times \text{Max. shear stress}} = \frac{\left(\frac{3WL}{2bd^2}\right)}{\left(2 \times \frac{3}{4} \frac{W}{b \times d}\right)} = \frac{L}{d}$$

## 9

## Direct and Bending Stresses

## 9.1. INTRODUCTION

Direct stress alone is produced in a body when it is subjected to an axial tensile or compressive load. And bending stress is produced in the body, when it is subjected to a bending moment. But if a body is subjected to axial loads and also bending moments, then both the stresses (*i.e.*, direct and bending stresses) will be produced in the body. In this chapter, we shall study the important cases of the members subjected to direct and bending stresses. Both these stresses act normal to a cross-section, hence the two stresses may be algebraically added into a single resultant stress.

## 9.2. COMBINED BENDING AND DIRECT STRESSES

Consider the case of a column\* subjected by a compressive load  $P$  acting along the axis of the column as shown in Fig. 9.1. This load will cause a direct compressive stress whose intensity will be uniform across the cross-section of the column.

Let  $\sigma_0$  = Intensity of the stress

$A$  = Area of cross-section

$P$  = Load acting on the column.

Then stress,

$$\sigma_0 = \frac{\text{Load}}{\text{Area}} = \frac{P}{A}$$

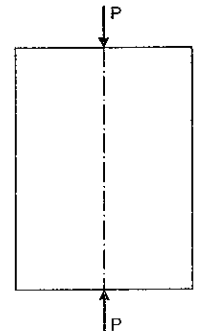

Fig. 9.1

Now consider the case of a column subjected by a compressive load  $P$  whose line of action is at a distance of ' $e$ ' from the axis of the column as shown in Fig. 9.2 (a). Here ' $e$ ' is known as eccentricity of the load. The eccentric load shown in Fig. 9.2 (a) will cause direct stress and bending stress. This is proved as discussed below :

1. In Fig. 9.2 (b), we have applied, along the axis of the column, two equal and opposite forces  $P$ . Thus three forces are acting now on the column. One of the forces is shown in Fig. 9.2 (c) and the other two forces are shown in Fig. 9.2 (d).

2. The force shown in Fig. 9.2 (c) is acting along the axis of the column and hence this force will produce a direct stress.

3. The forces shown in Fig. 9.2 (d) will form a couple, whose moment will be  $P \times e$ . This couple will produce a bending stress.

\* Column is a vertical member subjected to a compressive load.

Hence an eccentric\* load will produce a direct stress as well as a bending stress. By adding these two stresses algebraically, a single resultant stress can be obtained.

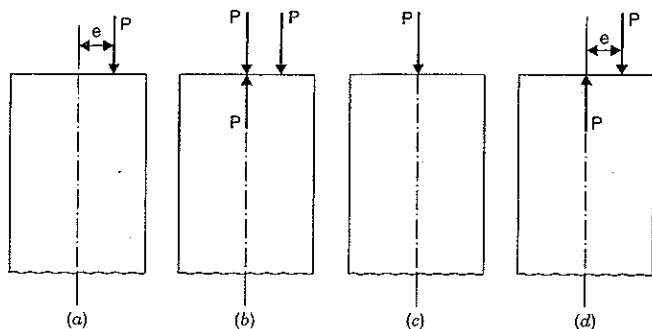

Fig. 9.2

### 9.3. RESULTANT STRESS WHEN A COLUMN OF RECTANGULAR SECTION IS SUBJECTED TO AN ECCENTRIC LOAD

A column of rectangular section subjected to an eccentric load is shown in Fig. 9.3. Let the load is eccentric with respect to the axis Y-Y as shown in Fig. 9.3 (b). It is mentioned in Art. 9.2 that an eccentric load causes direct stress as well as bending stress. Let us calculate these stresses.

Let  $P$  = Eccentric load on column

$e$  = Eccentricity of the load

$\sigma_0$  = Direct stress

$\sigma_b$  = Bending stress

$b$  = Width of column

$d$  = Depth of column

$\therefore$  Area of column section,  $A = b \times d$

Now moment due to eccentric load  $P$  is given by,

$$M = \text{Load} \times \text{eccentricity} \\ = P \times e$$

The direct stress ( $\sigma_0$ ) is given by,

$$\sigma_0 = \frac{\text{Load } (P)}{\text{Area}} = \frac{P}{A} \quad \dots(i)$$

This stress is uniform along the cross-section of the column.

The bending stress  $\sigma_b$  due to moment at any point of the column section at a distance  $y$  from the neutral axis Y-Y is given by

$$\frac{M}{I} = \frac{\sigma_b}{\pm y}$$

\* Eccentric load is a load whose line of action does not coincide with the axis of the column. The eccentricity of the load may be about one of the axis, or about both the axis.

$$\therefore \sigma_b = \pm \frac{M}{I} \times y \quad \dots(ii)$$

where  $I$  = Moment of inertia of the column section about the neutral axis Y-Y =  $\frac{d \cdot b^3}{12}$

Substituting the value of  $I$  in equation (ii), we get

$$\sigma_b = \pm \frac{M}{\frac{d \cdot b^3}{12}} \times y = \pm \frac{12 M}{d \cdot b^3} \times y$$

The bending stress depends upon the value of  $y$  from the axis Y-Y.

The bending stress at the extreme is obtained by substituting  $y = \frac{b}{2}$  in the above equation.

$$\therefore \sigma_b = \pm \frac{12 M}{d \cdot b^3} \times \frac{b}{2} = \pm \frac{6 M}{d \cdot b^2} \\ = \pm \frac{6 P \times e}{d \cdot b^2} \quad (\because M = P \times e) \\ = \pm \frac{6 P \times e}{d \cdot b \cdot b} = \pm \frac{6 P \times e}{A \times b} \\ (\because \text{Area} = b \times d = A)$$

The resultant stress at any point will be the algebraic sum of direct stress and bending stress.

If  $y$  is taken positive on the same side of Y-Y as the load, then bending stress will be of the same type as the direct stress. Here direct stress is compressive and hence bending stress will also be compressive towards the right of the axis Y-Y. Similarly bending stress will be tensile towards the left of the axis Y-Y. Taking compressive stress as positive and tensile stress as negative we can find the maximum and minimum stress at the extremities of the section. The stress will be maximum along layer BC and minimum along layer AD.

Let  $\sigma_{max}$  = Maximum stress (i.e., stress along BC)

$\sigma_{min}$  = Minimum stress (i.e., stress along AD)

Then  $\sigma_{max}$  = Direct stress + Bending stress

$$= \sigma_0 + \sigma_b \\ = \frac{P}{A} + \frac{6 P \cdot e}{A \cdot b} \\ = \frac{P}{A} \left( 1 + \frac{6 \times e}{b} \right) \quad \dots(9.1)$$

(Here bending stress is +ve)

and  $\sigma_{min}$  = Direct stress - Bending stress

$$= \sigma_0 - \sigma_b$$

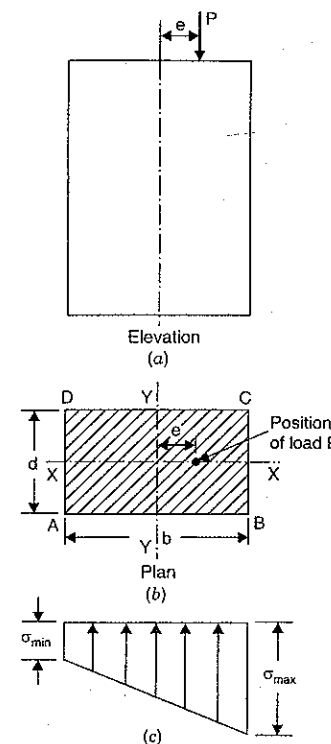

Fig. 9.3

$$= \frac{P}{A} - \frac{6P \cdot e}{A \cdot b} = \frac{P}{A} \left( 1 - \frac{6 \times e}{b} \right) \quad \dots(9.2)$$

These stresses are shown in Fig. 9.3 (c). The resultant stress along the width of the column will vary by a straight line law.

If in equation (9.2),  $\sigma_{min}$  is negative then the stress along the layer AD will be tensile. If  $\sigma_{min}$  is zero then there will be no tensile stress along the width of the column. If  $\sigma_{min}$  is positive then there will be only compressive stress along the width of the column.

**Problem 9.1.** A rectangular column of width 200 mm and of thickness 150 mm carries a point load of 240 kN at an eccentricity of 10 mm as shown in Fig. 9.4 (i). Determine the maximum and minimum stresses on the section.

**Sol. Given :**

Width,  $b = 200$  mm  
 Thickness,  $d = 150$  mm  
 $\therefore$  Area,  $A = b \times d$   
 $= 200 \times 150 = 30000$  mm<sup>2</sup>

Eccentric load,  
 $P = 240$  kN  
 $= 240000$  N

Eccentricity,  
 $e = 10$  mm

Let  $\sigma_{max}$  = Maximum stress, and  
 $\sigma_{min}$  = Minimum stress.

(i) Using equation (9.1), we get

$$\begin{aligned} \sigma_{max} &= \frac{P}{A} \left( 1 + \frac{6 \times e}{b} \right) \\ &= \frac{240000}{30000} \left( 1 + \frac{6 \times 10}{200} \right) \\ &= 8(1 + 0.3) = 10.4 \text{ N/mm}^2. \quad \text{Ans.} \end{aligned}$$

(ii) Using equation (9.2), we get

$$\begin{aligned} \sigma_{min} &= \frac{P}{A} \left( 1 - \frac{6 \times e}{b} \right) \\ &= \frac{240000}{30000} \left( 1 - \frac{6 \times 10}{200} \right) = 8(1 - 0.3) = 5.6 \text{ N/mm}^2. \quad \text{Ans.} \end{aligned}$$

These stresses are shown in Fig. 9.4 (ii).

**Problem 9.2.** If in Problem 9.1, the minimum stress on the section is given zero then find the eccentricity of the point load of 240 kN acting on the rectangular column. Also calculate the corresponding maximum stress on the section.

**Sol. Given :**

The data from Problem 9.1 is :

$b = 200$  mm,  $d = 150$  mm,  $P = 240000$  N,  $A = 30000$  mm<sup>2</sup>

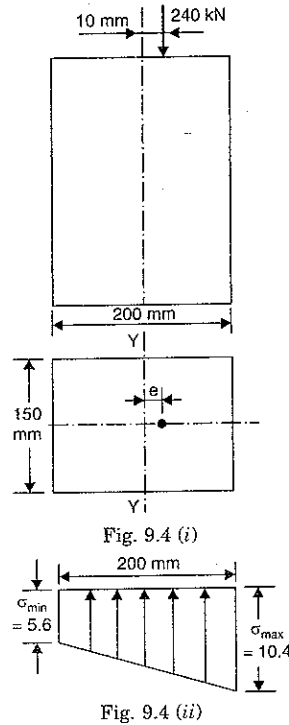

Minimum stress,

$$\sigma_{min} = 0$$

Let  $e$  = Eccentricity

Using equation (9.2), we get

$$\sigma_{min} = \frac{P}{A} \left( 1 - \frac{6 \times e}{b} \right)$$

$$\text{or } 0 = \frac{240000}{30000} \left( 1 - \frac{6 \times e}{200} \right)$$

$$\text{or } 1 - \frac{6 \times e}{200} = 0 \quad \text{or } 1 = \frac{6 \times e}{200}$$

$$\therefore e = \frac{200}{6} = 33.33 \text{ mm. Ans.}$$

Corresponding maximum stress is obtained by using equation (9.1).

$$\begin{aligned} \therefore \sigma_{max} &= \frac{P}{A} \left( 1 + \frac{6 \times e}{b} \right) \\ &= \frac{240000}{30000} \left( 1 + \frac{6 \times 200}{200} \right) = 8(1 + 1) = 16 \text{ N/mm}^2 \end{aligned}$$

The stresses are shown in Fig. 9.5.

**Problem 9.3.** If in Problem 9.1, the eccentricity is given 50 mm instead of 10 mm then find the maximum and minimum stresses on the section. Also plot these stresses along the width of the section.

**Sol. Given :**

The data from Problem 9.1 is :

$b = 200$  mm  
 $d = 150$  mm  
 $P = 240000$  N  
 $A = 30000$  mm<sup>2</sup>

Eccentricity,  
 $e = 50$  mm

(i) Maximum stress ( $\sigma_{max}$ ) is given by equation (9.1) as

$$\begin{aligned} \sigma_{max} &= \frac{P}{A} \left( 1 + \frac{6 \times e}{b} \right) \\ &= \frac{240000}{30000} \left( 1 + \frac{6 \times 50}{200} \right) = 8(1 + 1.5) = 20 \text{ N/mm}^2. \quad \text{Ans.} \end{aligned}$$

(ii) Minimum stress ( $\sigma_{min}$ ) is given by equation (9.2) as

$$\sigma_{min} = \frac{P}{A} \left( 1 - \frac{6 \times e}{b} \right)$$

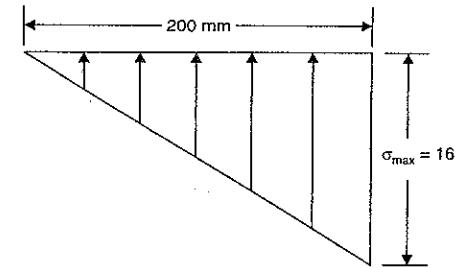

Fig. 9.5

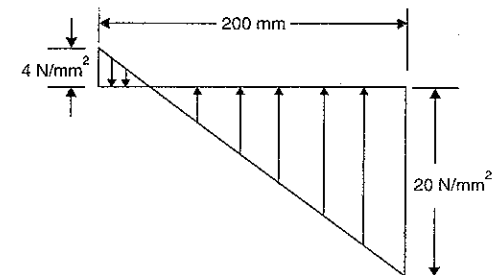

Fig. 9.6

$$= \frac{240000}{30000} \left( 1 - \frac{6 \times 50}{200} \right) = 8(1 - 1.5) = -4 \text{ N/mm}^2. \text{ Ans.}$$

Negative sign means tensile stress.

The stresses are plotted as shown in Fig. 9.6.

**Note.** From the above three problems, we have

(i) The minimum stress is zero when  $e = \frac{200}{6}$  mm or  $\frac{b}{6}$  mm (as  $b = 200$ ). This is clear from Problem 9.2.

(ii) The minimum stress is +ve (i.e., compressive) when  $e < \frac{b}{6}$ . This is clear from Problem 9.1 in which  $e = 10$  mm which is less than  $\frac{200}{6}$  (i.e., 33.33).

(iii) The minimum stress is -ve (i.e., tensile) when  $e > \frac{b}{6}$ . This is clear from Problem 9.3 in which  $e = 50$  mm which is more than  $\frac{200}{6}$  (i.e., 33.33).

**Problem 9.4.** The line of thrust, in a compression testing specimen 15 mm diameter, is parallel to the axis of the specimen but is displaced from it. Calculate the distance of the line of thrust from the axis when the maximum stress is 20% greater than the mean stress on a normal section.

**Sol.** Given :

Diameter,  $d = 15$  mm

$$\therefore \text{Area, } A = \frac{\pi}{4} \times 15^2 = 176.714 \text{ mm}^2$$

$\sigma_{max} = 20\%$  greater than mean

$$= \frac{120}{100} \times \text{mean stress} = 1.2 \times \text{mean stress.}$$

Let  $P =$  Compressive load on specimen  
 $e =$  Eccentricity

$$\text{Mean stress} = \frac{\text{Load}}{\text{Area}} = \frac{P}{176.714} \text{ N/mm}^2$$

We know that moment,

$$M = P \times e$$

Now bending stress is given by

$$\frac{M}{I} = \frac{\sigma_b}{y}$$

$$\therefore \sigma_b = \frac{M}{I} \times y$$

$\therefore$  Maximum bending stress will be when  $y = \pm \frac{d}{2}$ .

Hence maximum bending stress is given by,

$$\sigma_b = \frac{M}{I} \times \left( \pm \frac{d}{2} \right)$$

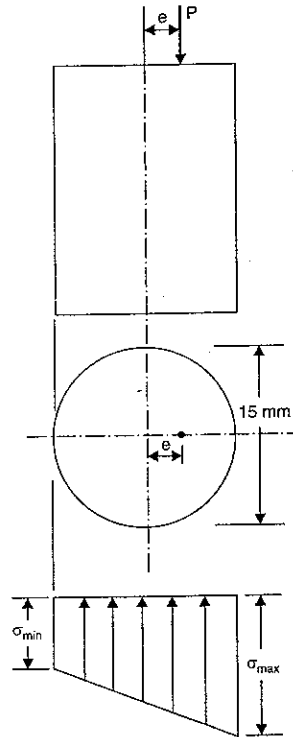

Fig. 9.7

$$= \pm \frac{M}{I} \times \frac{d}{2}$$

$$= \pm \frac{M}{\frac{\pi}{64} d^4} \times \frac{d}{2}$$

$$\left( \because I = \frac{\pi}{64} d^4 \right)$$

$$= \pm \frac{32 M}{\pi d^3}$$

$$= \pm \frac{32 P \times e}{\pi d^3}$$

$$\left( \because M = P \times e \right)$$

Direct stress due to load is given by,

$$\sigma_0 = \frac{P}{A} = \frac{P}{176.714}$$

$\therefore$  Maximum stress = Direct stress  $\times$  Bending stress

$$= \sigma_0 + \sigma_b$$

$$\text{or } \sigma_{max} = \frac{P}{176.714} + \frac{32 P \times e}{\pi d^3} \quad \dots(i)$$

But

$$\sigma_{max} = 1.2 \times \text{Mean stress} \quad \text{(given)}$$

$$= 1.2 \times \frac{P}{176.714}$$

$$\dots(ii) \left( \because \text{Mean stress} = \frac{P}{176.714} \right)$$

Equating equations (i) and (ii), we get

$$\frac{P}{176.714} + \frac{32 P \times e}{\pi d^3} = 1.2 \times \frac{P}{176.714}$$

$$\text{or } \frac{32 \times P \times e}{\pi d^3} = \frac{1.2 P}{176.714} - \frac{P}{176.714} = \frac{0.2 P}{176.714}$$

$$\text{or } \frac{32 \times e}{\pi d^3} = \frac{0.2}{176.714}$$

(Cancelling  $P$  to both sides)

$$\therefore e = \frac{0.2 \times \pi \times d^3}{32 \times 176.714} = \frac{0.2 \times \pi \times 15^3}{32 \times 176.714} = 0.375 \text{ mm. Ans.}$$

**Problem 9.5.** A hollow rectangular column of external depth 1 m and external width 0.8 m is 10 cm thick. Calculate the maximum and minimum stress in the section of the column if a vertical load of 200 kN is acting with an eccentricity of 15 cm as shown in Fig. 9.8.

**Sol.** Given :

External width,  $B = 0.8 \text{ m} = 800 \text{ mm}$

External depth,  $D = 1.0 \text{ m} = 1000 \text{ mm}$

Thickness of walls,  $t = 10 \text{ cm} = 100 \text{ mm}$

Inner width,  $b = B - 2 \times 100 = 800 - 200 = 600 \text{ mm}$

Inner depth,  $d = D - 2 \times 100 = 1000 - 2 \times 100 = 800 \text{ mm}$

$$\begin{aligned} \therefore \text{Area, } A &= B \times D - b \times d \\ &= 800 \times 1000 - 600 \times 800 \\ &= 800000 - 480000 \\ &= 320000 \text{ mm}^2 \end{aligned}$$

M.O.I. about Y-Y axis is given by,

$$\begin{aligned} I &= \frac{1000 \times 800^3}{12} - \frac{800 \times 600^3}{12} \\ &= 42.66 \times 10^9 - 14.4 \times 10^9 \\ &= 28.26 \times 10^9 \text{ mm}^4 \end{aligned}$$

Eccentric load,  $P = 200 \text{ kN} = 200,000 \text{ N}$

Eccentricity,  $e = 15 \text{ cm} = 150 \text{ mm}$

We know that the moment,

$$\begin{aligned} M &= P \times e \\ &= 200,000 \times 150 \\ &= 30,000,000 \text{ Nmm} \end{aligned}$$

The bending stress is given by,

$$\begin{aligned} \frac{M}{I} &= \frac{\sigma_b}{y} \\ \therefore \sigma_b &= \frac{M}{y} \times y \end{aligned}$$

Maximum bending stress will be when  $y = \pm 400$

$$\begin{aligned} \therefore \sigma_b &= \frac{M}{I} \times (\pm 400) \\ &= \pm \frac{30,000,000}{28.26 \times 10^9} \times 400 \\ &= \pm 0.4246 \text{ N/mm}^2 \end{aligned}$$

Direct stress is given by,

$$\begin{aligned} \sigma_0 &= \frac{P}{A} = \frac{200,000}{320,000} \\ &= 0.625 \text{ N/mm}^2 \end{aligned}$$

$$\begin{aligned} \therefore \text{Maximum stress} &= \sigma_0 + \sigma_b = 0.625 + 0.4246 \\ &= 1.0496 \text{ N/mm}^2 \text{ (Compressive). Ans.} \end{aligned}$$

$$\begin{aligned} \text{Minimum stress} &= \sigma_0 - \sigma_b = 0.625 - 0.4246 \\ &= 0.2004 \text{ N/mm}^2 \text{ (Compressive). Ans.} \end{aligned}$$

**Problem 9.6.** A short column of external diameter 40 cm and internal diameter 20 cm carries an eccentric load of 80 kN. Find the greatest eccentricity which the load can have without producing tension on the cross-section.

**Sol.** Given :

$$\begin{aligned} \text{External dia., } D &= 40 \text{ cm} = 400 \text{ mm} \\ \text{Internal dia., } d &= 20 \text{ cm} = 200 \text{ mm} \end{aligned}$$

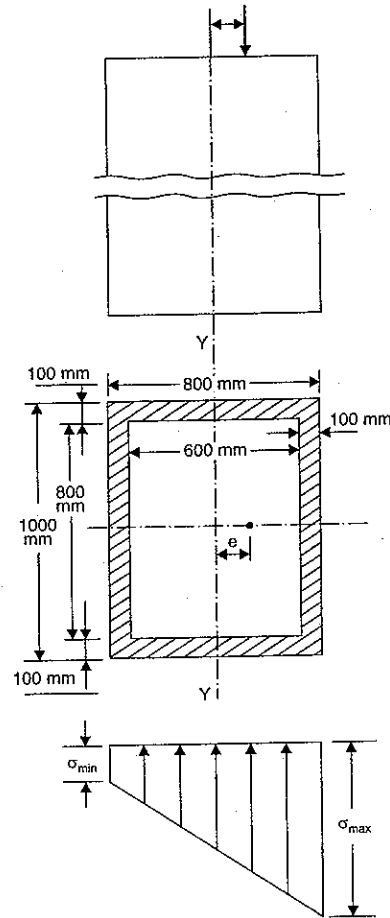

Fig. 9.8

$\therefore$  Area of cross-section,

$$\begin{aligned} A &= \frac{\pi}{4} (D^2 - d^2) \\ &= \frac{\pi}{4} (400^2 - 200^2) = 30,000 \times \pi \text{ mm}^2 \end{aligned}$$

Moment of inertia

$$\begin{aligned} I &= \frac{\pi}{64} (D^4 - d^4) \\ &= \frac{\pi}{64} (400^4 - 200^4) = 3.75 \times 10^8 \times \pi \text{ mm}^4 \end{aligned}$$

Eccentric load,  $P = 80 \text{ kN} = 80,000 \text{ N}$

Let  $e =$  Eccentricity when there is no tension.

$$\text{Now direct stress, } \sigma_0 = \frac{P}{A} = \frac{80,000}{30,000 \times \pi} \quad \dots(i)$$

We know that moment,

$$M = P \times e = 80,000 \times e$$

Now bending stress ( $\sigma_b$ ) is given by

$$\begin{aligned} \frac{M}{I} &= \frac{\sigma_b}{y} \\ \therefore \sigma_b &= \frac{M \times y}{I} \end{aligned}$$

The bending stress will be maximum when

$$y = \pm \frac{D}{2} = \pm \frac{400}{2} = \pm 200 \text{ mm}$$

$\therefore$  Maximum bending stress is given by,

$$\begin{aligned} \sigma_b &= \frac{M \times (\pm 200)}{I} = \pm \frac{M \times 200}{I} \\ &= \pm \frac{80,000 \times e \times 200}{3.75 \times 10^8 \times \pi} \end{aligned}$$

Now minimum stress is given by,

$$\begin{aligned} \sigma_{min} &= \sigma_0 - \sigma_b \\ &= \frac{80,000}{30,000 \times \pi} - \frac{80,000 \times e \times 200}{3.75 \times 10^8 \times \pi} \end{aligned}$$

There will be no tension if  $\sigma_{min} = 0$

$\therefore$  For no tension, we have

$$0 = \frac{80,000}{30,000 \times \pi} - \frac{80,000 \times e \times 200}{3.75 \times 10^8 \times \pi}$$

$$\text{or } \frac{80,000}{30,000 \times \pi} = \frac{80,000 \times e \times 200}{3.75 \times 10^8 \times \pi}$$

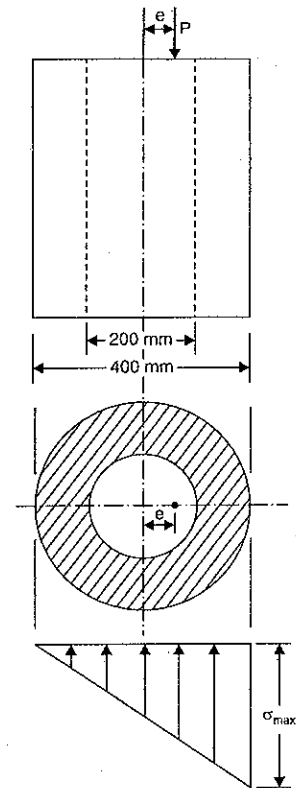

Fig. 9.9

... (ii)



or

$$e = \frac{3.75 \times 10^8 \times \pi \times 80000}{30000 \times \pi \times 80000 \times 200} = 62.5 \text{ mm. Ans.}$$

**Problem 9.7.** If in the Problem 9.6, the eccentricity of the point load is given as 150 mm, then calculate the maximum and minimum stress in the section.

**Sol.** Given :

The data from Problem 9.6 is :

$$D = 400 \text{ mm}, d = 200 \text{ mm}$$

$$P = 80000 \text{ N}, A = 30000 \times \pi \text{ mm}^2$$

$$\text{Moment of inertia, } I = 3.75 \times 10^8 \times \pi \text{ mm}^4$$

$$\text{Eccentricity, } e = 150 \text{ mm}$$

$$\text{Now direct stress, } \sigma_0 = \frac{P}{A} = \frac{80000}{30000 \times \pi} = 0.8488 \text{ N/mm}^2$$

We know that moment,

$$M = P \times e = 80000 \times 150 = 12000000 \text{ Nmm}$$

Maximum bending stress is given by,

$$\sigma_b = \frac{M \times y_{max}}{I} = \frac{12000000 \times (\pm 200)}{3.75 \times 10^8 \times \pi} \quad (\because y_{max} = \pm 200 \text{ mm})$$

$$= \pm 2.037 \text{ N/mm}^2$$

$$\therefore \text{Maximum stress} = \sigma_0 + \sigma_b = 0.8488 + 2.037 = 2.8858 \text{ N/mm}^2 \text{ (Compressive). Ans.}$$

$$\text{Minimum stress} = \sigma_0 - \sigma_b = 0.8488 - 2.037 = -1.1882 \text{ N/mm}^2 \text{ (Tensile). Ans.}$$

The stress distribution across the width is shown in Fig. 9.10.

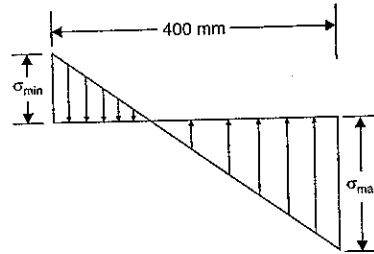

Fig. 9.10

#### 9.4. RESULTANT STRESS WHEN A COLUMN OF RECTANGULAR SECTION IS SUBJECTED TO A LOAD WHICH IS ECCENTRIC TO BOTH AXES

A column of rectangular section ABCD, subjected to a load which is eccentric to both axes, is shown in Fig. 9.11.

Let  $P$  = Eccentric load on column

$e_x$  = Eccentricity of load about X-X axis

$e_y$  = Eccentricity of load about Y-Y axis

$b$  = Width of column

$d$  = Depth of column

$\sigma_0$  = Direct stress

$\sigma_{bx}$  = Bending stress due to eccentricity  $e_x$

$\sigma_{by}$  = Bending stress due to eccentricity  $e_y$

$M_x$  = Moment of load about X-X axis

$$= P \times e_x$$

$M_y$  = Moment of load about Y-Y axis

$$= P \times e_y$$

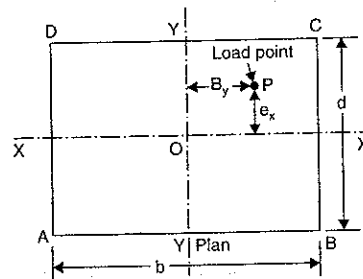

Fig. 9.11

$I_{xx}$  = Moment of inertia about X-X axis

$$= \frac{bd^3}{12}$$

$I_{yy}$  = Moment of inertia about Y-Y axis

$$= \frac{db^3}{12}$$

Now the eccentric load is equivalent to a central load  $P$ , together with a bending moment  $P \times e_y$  about Y-Y and a bending moment  $P \times e_x$  about X-X.

(i) The direct stress ( $\sigma_0$ ) is given by,

$$\sigma_0 = \frac{P}{A} \quad \dots(i)$$

(ii) The bending stress due to eccentricity  $e_y$  is given by,

$$\sigma_{by} = \frac{M_y \times x}{I_{yy}} = \frac{P \times e_y \times x}{I_{yy}} \quad (\because M_y = P \times e_y) \quad \dots(ii)$$

In the above equation  $x$  varies from  $-\frac{b}{2}$  to  $+\frac{b}{2}$ .

(iii) The bending stress due to eccentricity  $e_x$  is given by,

$$\sigma_{bx} = \frac{M_x \times y}{I_{xx}} = \frac{P \times e_x \times y}{I_{xx}}$$

In the above equation,  $y$  varies from  $-\frac{d}{2}$  to  $+\frac{d}{2}$ .

The resultant stress at any point on the section

$$= \sigma_0 \pm \sigma_{by} \pm \sigma_{bx}$$

$$= \frac{P}{A} \pm \frac{M_y \times x}{I_{yy}} \pm \frac{M_x \cdot y}{I_{xx}} \quad \dots(9.3)$$

(i) At the point C, the co-ordinates  $x$  and  $y$  are positive hence the resultant stress will be maximum.

(ii) At the point A, the co-ordinates  $x$  and  $y$  are negative and hence the resultant stress will be minimum.

(iii) At the point B,  $x$  is +ve and  $y$  is -ve and hence resultant stress

$$= \frac{P}{A} + \frac{M_y \cdot x}{I_{yy}} - \frac{M_x \cdot y}{I_{xx}}$$

(iv) At the point D,  $x$  is -ve and  $y$  is +ve and hence resultant stress

$$= \frac{P}{A} - \frac{M_y \cdot x}{I_{yy}} + \frac{M_x \cdot y}{I_{xx}}$$

**Problem 9.8.** A short column of rectangular cross-section 80 mm by 60 mm carries a load of 40 kN at a point 20 mm from the longer side and 35 mm from the shorter side. Determine the maximum compressive and tensile stresses in the section.

Sol. Given :

Width,  $b = 80 \text{ mm}$   
 Depth,  $d = 60 \text{ mm}$   
 $\therefore$  Area,  $A = 80 \times 60 = 4800 \text{ mm}^2$   
 Point load,  $P = 40 \text{ kN} = 40000 \text{ N}$   
 Eccentricity of load about X-X axis,  
 $e_x = 10 \text{ mm}$   
 Eccentricity of load about Y-Y axis,  
 $e_y = 5 \text{ mm}$

Moment of load about X-X axis,  
 $M_x = P \times e_x = 40000 \times 10$   
 $= 400000 \text{ Nmm}$

Moment of load about Y-Y axis,  
 $M_y = P \times e_y = 40000 \times 5 = 200000 \text{ Nmm}$

Moment of inertia about X-X axis,  
 $I_{xx} = \frac{1}{12} \times 80 \times 60^3 = 1440000 \text{ mm}^4$

Similarly,  
 $I_{yy} = \frac{1}{12} \times 60 \times 80^3 = 2560000 \text{ mm}^4$

(i) The maximum compressive stress will be at point C where  $x$  and  $y$  are positive. The value of  $x = 40 \text{ mm}$  and  $y = 30 \text{ mm}$  at C.

Hence maximum compressive stress is given by equation (9.3)

$$\begin{aligned} &= \frac{P}{A} + \frac{M_y \times x}{I_{yy}} + \frac{M_x \times y}{I_{xx}} \quad (\text{Taking +ve sign}) \\ &= \frac{40000}{4800} + \frac{200000 \times 40}{2560000} + \frac{400000 \times 30}{1440000} \\ &= 8.33 + 3.125 + 8.33 = 19.785 \text{ N/mm}^2. \quad \text{Ans.} \end{aligned}$$

(ii) The maximum tensile stress will be at point A where  $x = -40 \text{ mm}$  and  $y = -30 \text{ mm}$ .

Hence using equation (9.3), we get

$$\begin{aligned} \text{Resultant stress at A} &= \frac{P}{A} + \frac{M_y \times x}{I_{yy}} + \frac{M_x \times y}{I_{xx}} \\ &= \frac{40000}{4800} - \frac{200000 \times 40}{2560000} - \frac{400000 \times 30}{1440000} \\ &= 8.33 - 3.125 - 8.33 = -3.125 \text{ N/mm}^2. \quad \text{Ans.} \end{aligned}$$

**Problem 9.9.** A column is rectangular in cross-section of  $300 \text{ mm} \times 400 \text{ mm}$  in dimensions. The column carries an eccentric point load of  $360 \text{ kN}$  on one diagonal at a distance of quarter diagonal length from a corner. Calculate the stresses at all four corners. Draw stress distribution diagrams for any two adjacent sides. (Bhavnagar University, Feb. 1992)

Sol. Given :

Width,  $b = 300 \text{ mm}$   
 Depth,  $d = 400 \text{ mm}$

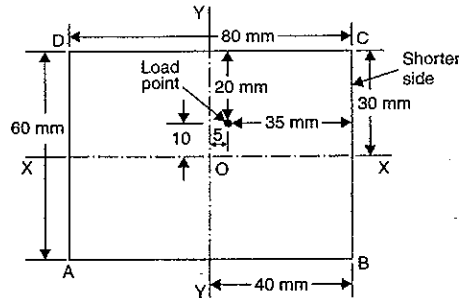

Fig. 9.12

$\therefore$  Area,  $A = b \times d = 300 \times 400$   
 $= 12 \times 10^4 \text{ mm}^2$

Eccentric load,  $P = 360 \text{ kN} = 360000 \text{ N}$

The eccentric load is acting at point E, where distance EC = one quarter of diagonal AC.

Now diagonal  $AC = \sqrt{300^2 + 400^2} = 500$

$\therefore$  In  $\triangle CAB$ ,  $\tan \theta = \frac{4}{3}$

$\cos \theta = \frac{3}{5}$  and  $\sin \theta = \frac{4}{5}$

Also  $OE = EC = \frac{1}{4}$  of AC  
 $= \frac{1}{4} \times 500 = 125 \text{ mm}$

And  $e_x = EF = OE \sin \theta = 125 \times \frac{4}{5} = 100 \text{ mm}$

$e_y = OF = OE \cos \theta = 125 \times \frac{3}{5} = 75 \text{ mm}$

Moment of load about x-x axis,

$$M_x = P \times e_x = 360000 \times 100 = 36000000 \text{ Nmm}$$

Moment of load about y-y axis,

$$M_y = P \times e_y = 360000 \times 75 = 27000000 \text{ Nmm}$$

Also  $I_{xx} = \frac{1}{12} \times 300 \times 400^3 = 16 \times 10^8 \text{ mm}^4$

$I_{yy} = \frac{1}{12} \times 400 \times 300^3 = 9 \times 10^8 \text{ mm}^4$

The resultant stress at any point is given by equation (9.3) as

$$\text{Resultant stress} = \frac{P}{A} + \frac{M_y \times x}{I_{yy}} + \frac{M_x \times y}{I_{xx}}$$

(i) Resultant stress at point C

At point C,  $x = 150 \text{ mm}$  and  $y = 200 \text{ mm}$

$\therefore$  Resultant stress at C

$$\begin{aligned} &= \frac{P}{A} + \frac{M_y \times 150}{I_{yy}} + \frac{M_x \times 200}{I_{xx}} \\ &= \frac{360000}{12 \times 10^4} + \frac{27000000 \times 150}{9 \times 10^8} + \frac{36000000 \times 200}{16 \times 10^8} \\ &= 3 + 4.5 + 4.5 \text{ N/mm}^2 \\ &= 12 \text{ N/mm}^2 \text{ (compressive)}. \quad \text{Ans.} \end{aligned}$$

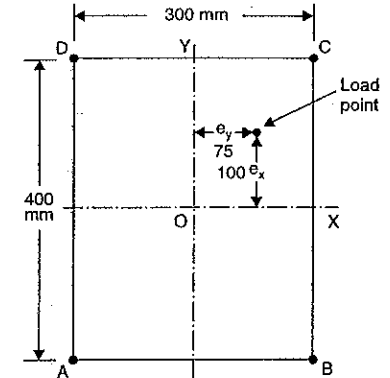

Fig. 9.12 (a)

(ii) Resultant stress at point B

At point B,  $x = 150 \text{ mm}$  and  $y = -200 \text{ mm}$

$$\begin{aligned} \text{Resultant stress at B} &= \frac{P}{A} + \frac{M_y \times 150}{I_{yy}} + \frac{M_x \times (-200)}{16 \times 10^8} \\ &= \frac{360000}{12 \times 10^4} + \frac{27000000 \times 150}{9 \times 10^8} - \frac{36000000 \times 200}{16 \times 10^8} \\ &= 3 + 4.5 - 4.5 \\ &= 3 \text{ N/mm}^2 \text{ (compressive). Ans.} \end{aligned}$$

(iii) Resultant stress at point A

At point A,  $x = -150 \text{ mm}$  and  $y = -200 \text{ mm}$

$\therefore$  Resultant stress at point A

$$\begin{aligned} &= \frac{P}{A} + \frac{M_y \times (-150)}{I_{yy}} + \frac{M_x \times (-200)}{I_{xx}} \\ &= \frac{360000}{12 \times 10^4} - \frac{27000000 \times 150}{9 \times 10^8} - \frac{36000000 \times 200}{16 \times 10^8} \\ &= 3 - 4.5 - 4.5 \\ &= -6 \text{ N/mm}^2 \text{ (Tensile). Ans.} \end{aligned}$$

(iv) Resultant stress at point D

At point D,  $x = -150 \text{ mm}$  and  $y = 200 \text{ mm}$

$\therefore$  Resultant stress at point D

$$\begin{aligned} &= \frac{P}{A} + \frac{M_y \times (-150)}{I_{yy}} + \frac{M_x \times 200}{I_{xx}} \\ &= \frac{360000}{12 \times 10^4} - \frac{27000000 \times 150}{9 \times 10^8} + \frac{36000000 \times 200}{16 \times 10^8} \\ &= 3 - 4.5 + 4.5 \\ &= 3 \text{ N/mm}^2 \text{ (compressive). Ans.} \end{aligned}$$

Stress distribution for AB and BC (i.e., two adjacent sides)

Fig. 9.12 (b) shows the stress distribution along two adjacent sides (i.e., AB and BC). At point A, resultant stress is  $6 \text{ N/mm}^2$  (tensile) whereas at point B, the resultant stress is  $3 \text{ N/mm}^2$  (compressive). Take  $AE = 6 \text{ N/mm}^2$  and  $BF = 3 \text{ N/mm}^2$ . Join E to F.

For side BC, the resultant stress at B is  $3 \text{ N/mm}^2$  (compressive) whereas at point C the resultant stress is  $12 \text{ N/mm}^2$  (compressive).

Take  $BH = 3 \text{ N/mm}^2$  (compressive) and  $CG = 12 \text{ N/mm}^2$  (compressive).

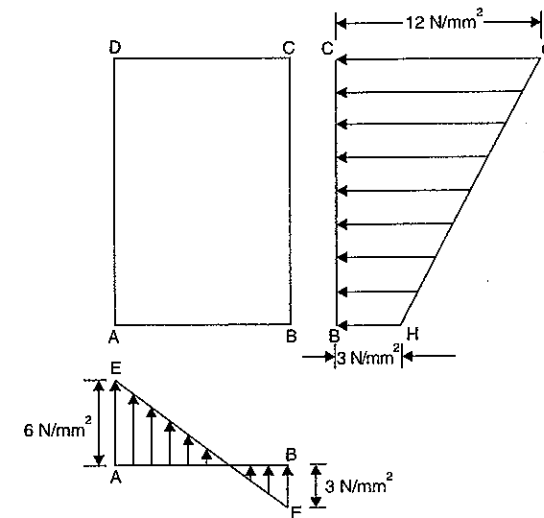

Fig. 9.12 (b)

**Problem 9.10.** A masonry pier of  $3 \text{ m} \times 4 \text{ m}$  supports a vertical load of  $80 \text{ kN}$  as shown in Fig. 9.13.

(a) Find the stresses developed at each corner of the pier.

(b) What additional load should be placed at the centre of the pier, so that there is no tension anywhere in the pier section?

(c) What are the stresses at the corners with the additional load in the centre?

**Sol.** Given :

Width  $b = 4 \text{ m}$

Depth,  $d = 3 \text{ m}$

$\therefore$  Area,  $A = 4 \times 3 = 12 \text{ m}^2$

Point load,  $P = 80 \text{ kN}$

Eccentricity of load about X-X axis,

$$e_x = 0.5 \text{ m}$$

Eccentricity of load about Y-Y axis,

$$e_y = 1.0 \text{ m}$$

Moment of load about X-X axis,

$$M_x = P \times e_x = 80 \times 0.5 = 40 \text{ kNm}$$

Similarly,  $M_y = P \times e_y = 80 \times 1.0 = 80 \text{ kNm}$

Moment of inertia about X-X axis,

$$I_{xx} = \frac{1}{12} \times 4 \times 3^3 = 9 \text{ m}^4$$

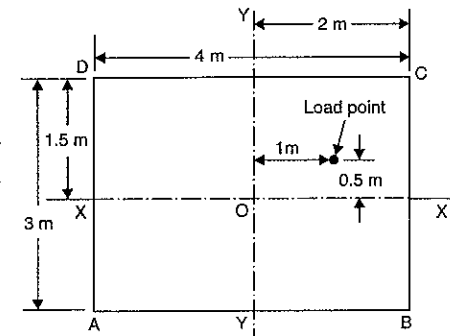

Fig. 9.13

Similarly,  $I_{yy} = \frac{1}{12} \times 3 \times 4^3 = 16 \text{ m}^4$ .

(a) Stresses developed at each corner of the pier

The resultant stress at any point is given by equation (9.3).

$$\text{Hence resultant stress} = \frac{P}{A} + \frac{M_y \times x}{I_{yy}} + \frac{M_x \times y}{I_{xx}} \quad \dots(i)$$

(i) At point A,  $x = -2.0 \text{ m}$  and  $y = -1.5 \text{ m}$ . Hence resultant stress at A (i.e.,  $\sigma_A$ ) is obtained by substituting these values in the above equation (i).

$$\begin{aligned} \therefore \sigma_A &= \frac{80}{12} + \frac{80 \times (-2.0)}{16} + \frac{40 \times (-1.5)}{9} \\ &= 6.66 - 10 - 6.66 \\ &= -10 \text{ kN/m}^2 \text{ (Tensile). Ans.} \end{aligned}$$

(ii) A point B,  $x = 2.0 \text{ m}$  and  $y = -1.5 \text{ m}$ . Hence resultant stress at B (i.e.,  $\sigma_B$ ) is obtained by substituting these values in equation (i).

$$\begin{aligned} \therefore \sigma_B &= \frac{80}{12} + \frac{80 \times 2.0}{16} + \frac{40 \times (-1.5)}{9} \\ &= 6.66 + 10 - 6.66 \\ &= 10 \text{ kN/m}^2 \text{ (Compressive). Ans.} \end{aligned}$$

(iii) At point C,  $x = 2.0 \text{ m}$  and  $y = 1.5 \text{ m}$ . Hence resultant stress at C (i.e.,  $\sigma_C$ ) is given by,

$$\begin{aligned} \therefore \sigma_C &= \frac{80}{12} + \frac{80 \times 2.0}{16} + \frac{40 \times 1.5}{9} \\ &= 6.66 + 10 + 6.66 \\ &= 23.33 \text{ kN/m}^2 \text{ (Compressive). Ans.} \end{aligned}$$

(iv) At point D,  $x = -2.0 \text{ m}$  and  $y = 1.5 \text{ m}$ . Hence resultant stress at D (i.e.,  $\sigma_D$ ) is given by,

$$\begin{aligned} \therefore \sigma_D &= \frac{80}{12} + \frac{80 \times (-2.0)}{16} + \frac{40 \times 1.5}{9} \\ &= 6.66 - 10 + 6.66 \\ &= +3.33 \text{ kN/m}^2 \text{ (Compressive). Ans.} \end{aligned}$$

(b) Additional load at the centre of the pier, so that there is no tension anywhere in the pier section.

Let  $W$  = Additional load (in kN) placed at the centre for no tension anywhere in the pier section.

The above load is compressive and will cause a compressive stress

$$= \frac{W}{A} = \frac{W}{12} \text{ kN/m}^2 \quad (\because A = 12 \text{ m}^2)$$

As this load is placed at the centre, it will produce a uniform compressive stress across the section of the pier. But we know that there is tensile stress at point A having magnitude =  $10 \text{ kN/m}^2$ . Hence the compressive stress due to load  $W$  should be equal to tensile stress at A.

$$\therefore \frac{W}{12} = 10$$

or  $W = 10 \times 12 = 120 \text{ kN. Ans.}$

(c) Stresses at the corners with the additional load at the centre

$$\text{Stress due to additional load} = \frac{W}{A} = \frac{120}{12} = 10 \text{ kN/m}^2 \text{ (Compressive)}$$

This stress is uniform across the cross-section of the pier. Hence to find the stresses at the corners with this additional load, we must add the stress  $10 \text{ kN/m}^2$  in each value of the stresses already existing in the corners.

$$\therefore \text{Stress at A, } \sigma_A = -10 + 10 = 0. \text{ Ans.}$$

$$\text{Similarly, } \sigma_B = 10 + 10 = 20 \text{ kN/m}^2. \text{ Ans.}$$

$$\sigma_C = 23.33 + 10 = 33.33 \text{ kN/m}^2. \text{ Ans.}$$

$$\text{and } \sigma_D = 3.33 + 10 = 13.33 \text{ kN/m}^2. \text{ Ans.}$$

### 9.5. RESULTANT STRESS FOR UNSYMMETRICAL COLUMNS WITH ECCENTRIC LOADING

In case of unsymmetrical columns which are subjected to eccentric loading, first the centre of gravity (i.e., C.G.) of the unsymmetrical section is determined. Then the moment of inertia of the section about the axis passing through the C.G. is calculated. After that the distances between the corners of the section and its C.G. is obtained. By using the values of the moment of inertia and distances of the corner from the C.G. of the section, the stresses on the corners are then determined.

**Problem 9.11.** A short column has a square section  $300 \text{ mm} \times 300 \text{ mm}$  with a square hole of  $150 \text{ mm} \times 150 \text{ mm}$  as shown in Fig. 9.14. It carries an eccentric load of  $1800 \text{ kN}$ , located as shown in the figure. Determine the maximum compressive and tensile stress across the section.

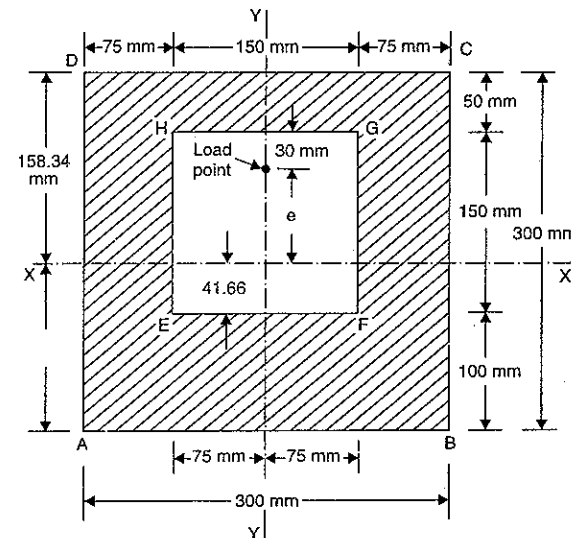

Fig. 9.14

**Sol. Given :**

Dimension of column =  $300 \text{ mm} \times 300 \text{ mm}$

Dimension of hole =  $150 \text{ mm} \times 150 \text{ mm}$

$$\begin{aligned} \therefore \text{Area of section, } A &= 300 \times 300 - 150 \times 150 \\ &= 90000 - 22500 \\ &= 67500 \text{ mm}^2 \end{aligned}$$

$$\text{Point load, } P = 1800 \text{ kN} = 1800000 \text{ N}$$

The point load is acting on Y-Y axis. The given section is also symmetrical about Y-Y axis. But it is unsymmetrical to X-X axis. Let us first find the position of X-X axis. For this, find the distance of C.G. from the bottom line AB. Let  $\bar{y}$  is the distance of the C.G. of the section from the bottom line AB.

$$\text{Then } \bar{y} = \frac{A_1 y_1 + A_2 y_2}{(A_1 + A_2)}$$

where  $A_1$  = Area of outer square =  $300 \times 300 = 90000 \text{ mm}^2$

$y_1$  = Distance of C.G. of outer square from line AB = 150 mm

$A_2$  = Area of square hole =  $150 \times 150 = 22500 \text{ mm}^2 = -22500 \text{ mm}^2$

(-ve sign due to cut out portion)

$y_2$  = Distance of C.G. of square hole from line AB =  $100 + \frac{150}{2} = 175 \text{ mm}$

$$\begin{aligned} \therefore \bar{y} &= \frac{90000 \times 150 - 22500 \times 175}{(90000 - 22500)} \\ &= \frac{13500000 - 3937500}{67500} = 141.66 \text{ mm} \end{aligned}$$

$\therefore$  The axis X-X lies at a distance 141.66 mm from line AB or at a distance of  $300 - 141.66 = 158.34 \text{ mm}$  from line CD.

The load is unsymmetrical to X-X axis.

Hence eccentricity,  $e = 158.34 - (50 + 30) = 78.34 \text{ mm}$

$\therefore$  Moment about X-X axis,

$$\begin{aligned} M &= P \times e = 1800000 \times 78.34 \\ &= 14101200 \text{ Nmm} \end{aligned}$$

Now let us calculate the moment of inertia of the section about X-X axis.

Let  $I_1$  = M.O.I. of outer square ABCD about X-X axis.

= M.O.I. of ABCD about an axis parallel to X-X and passing through its C.G. + Area of ABCD (Distance of C.G. of ABCD from X-X axis)<sup>2</sup>

$$= \frac{300 \times 300^3}{12} + 300 \times 300 \times (158.34 - 150)^2$$

$$= 675000000 + 6260004 = 681260004 \text{ mm}^4$$

$I_2$  = M.O.I. of square hole about X-X axis

= M.O.I. of hole about its C.G. + Area of hole (Distance of C.G. of hole from X-X)<sup>2</sup>

$$= \frac{150 \times 150^3}{12} = 150 \times 150(175 - 141.66)^2$$

$$= 42187500 + 25010001 = 67197501 \text{ mm}^4$$

$\therefore$  Net moment of inertia of the section about X-X axis is given by

$$\begin{aligned} I &= I_1 - I_2 \\ &= 681260004 - 67197501 = 614062503 \text{ mm}^4 \end{aligned}$$

Now direct stress is given by,

$$\sigma_0 = \frac{P}{A} = \frac{1800000}{67500} = 26.66 \text{ N/mm}^2$$

This stress is uniform across the section.

Bending stress is given by,

$$\frac{M}{I} = \frac{\sigma_b}{y}$$

or

$$\sigma_b = \frac{M \times y}{I} \quad \dots(i)$$

The maximum value of  $y$  from X-X axis is 158.34 mm. This is the distance of the line CD from X-X axis. As load is acting above the X-X axis, hence the bending stress will be compressive on the edge CD. This stress is obtained by substituting  $y = 158.34 \text{ mm}$  in equation (i).

$\therefore$  Bending stress at the edge CD due to moment

$$\begin{aligned} &= \frac{M \times 158.34}{614062503} = \frac{141012000 \times 158.34}{614062503} \\ &= 36.36 \text{ N/mm}^2 \text{ (Compressive)}. \end{aligned}$$

Bending stress at the edge AB will be tensile. The distance of AB from X-X is 141.66 mm.

Bending stress at the edge AB due to moment will be obtained by substituting  $y = -141.66$  in equation (i).

$\therefore$  Bending stress at the edge AB due to moment

$$\begin{aligned} &= -\frac{M \times 141.66}{I} = -\frac{141012000 \times 141.66}{614062503} \text{ (Tensile)} \\ &= -32.529 \text{ N/mm}^2 \end{aligned}$$

$\therefore$  Resultant stress at the edge CD

$$\begin{aligned} &= \sigma_0 + \sigma_b \\ &= 26.66 + 36.36 = 63.32 \text{ N/mm}^2 \text{ (Compressive). Ans.} \end{aligned}$$

and resultant stress at the edge AB

$$= 26.66 - 32.529 = -5.869 \text{ (Tensile). Ans.}$$

**Problem 9.12.** A short column has a rectangular section 160 mm  $\times$  200 mm with a circular hole of 80 mm diameter as shown in Fig. 9.15. It carries an eccentric load of 100 kN, at a point as shown in the figure. Determine the stresses at the four corners of the section.

**Sol.** Given :

Width,  $B = 160 \text{ mm}$

Depth,  $D = 200 \text{ mm}$

Area of rectangular ABCD,

$$A_1 = 160 \times 200 = 32000 \text{ mm}^2$$

Dia. of hole,  $d = 80 \text{ mm}$

$$\therefore \text{Area of hole, } A_2 = \frac{\pi}{4} \times 80^2 = 5026.5 \text{ mm}^2$$

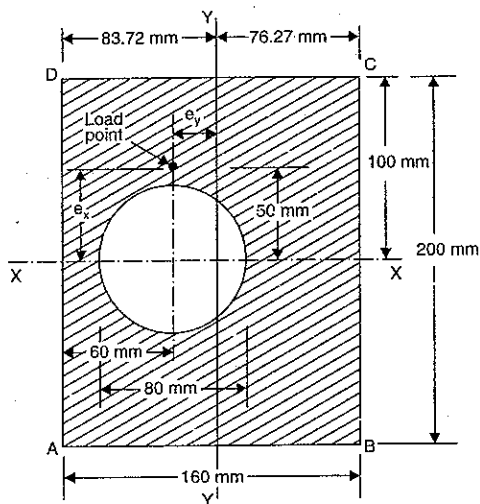

Fig. 9.15

∴ Area of section,  $A = A_1 - A_2 = 32000 - 5026.5 = 26973.5 \text{ mm}^2$

Eccentric load,  $P = 100 \text{ kN} = 100 \times 10^3 \text{ N}$

The given section is symmetrical about X-X axis. But it is unsymmetrical to Y-Y axis.

Let us first find the position of Y-Y axis. For this find the distance of the C.G. of the section from the reference line AD. Let  $\bar{x}$  is the distance of the C.G. of the section from the reference line AD.

Then 
$$\bar{x} = \frac{A_1 x_1 + A_2 x_2}{(A_1 + A_2)}$$

where  $A_1 = \text{Area of rectangle } ABCD = 32000 \text{ mm}^2$

$x_1 = \text{Distance of C.G. of rectangle } ABCD \text{ from reference line } AD = 80 \text{ mm}$

$A_2 = \text{Area of hole} = - 5026.5 \text{ mm}^2$  (–ve sign due to cut out portion)

$x_2 = \text{Distance of C.G. of hole from line } AD = 60 \text{ mm}$

∴ 
$$\bar{x} = \frac{32000 \times 80 - 5026.5 \times 60}{(32000 - 5026.5)} = \frac{2560000 - 301590}{26973.5} = 83.73 \text{ mm.}$$

Hence the axis Y-Y will lie at a distance of 83.73 mm from the line AD or at a distance of  $160 - 83.73 = 76.27 \text{ mm}$  from line BC as shown in Fig. 9.15.

The load is unsymmetrical to X-X axis as well as Y-Y axis.

Eccentricity of load about X-X axis,  $e_x = 50 \text{ mm}$

Eccentricity of load about Y-Y axis,  $e_y = 83.73 - 60 = 23.73 \text{ mm}$

Moment of eccentric load about X-X axis,  $M_x = P \times e_x = 100 \times 10^3 \times 50 = 5 \times 10^6 \text{ Nmm}$  ... (i)

Moment of eccentric load about Y-Y axis,  $M_y = P \times e_y = 100 \times 10^3 \times 23.73 = 2.373 \times 10^6 \text{ Nmm}$  ... (ii)

Now find the moment of inertia of the section about X-X axis and Y-Y axis.

Let  $I_{xx_1} = \text{M.O.I. of rectangle } ABCD \text{ about X-X axis}$   
 $= \text{M.O.I. of rectangle about its C.G.} + \text{Area of rectangle (Distance of C.G. of } ABCD \text{ from X-X axis)}^2$   
 $= \frac{160 \times 200^3}{12} + 160 \times 200 (0)$   
 $= 1.066 \times 10^8 \text{ mm}^4$

$I_{xx_2} = \text{M.O.I. of the hole about X-X axis}$   
 $= \frac{\pi}{64} \times 80^4 = 2.01 \times 10^6 \text{ mm}^4$

The moment of inertia of the section about X-X is given by

∴  $I_{xx} = I_{xx_1} - I_{xx_2} = 1.066 \times 10^8 - 2.01 \times 10^6 = 104.59 \times 10^6 \text{ mm}^4$  ... (iii)

Similarly,  $I_{yy} = I_{yy_1} - I_{yy_2}$  ... (iv)

where  $I_{yy_1} = \text{M.O.I. of } ABCD \text{ about Y-Y axis}$   
 $= \text{M.O.I. of } ABCD \text{ about its C.G.} + A_1 (\text{Distance of C.G. of } ABCD \text{ from Y-Y})^2$   
 $= \frac{200 \times 160^3}{12} + 200 \times 160 (83.73 - 80)^2$   
 $= 6.826 \times 10^7 + 4.45 \times 10^5$   
 $= 687.05 \times 10^5 \text{ mm}^4$

and  $I_{yy_2} = \text{M.O.I. of hole about Y-Y axis}$   
 $= \text{M.O.I. of hole about its C.G.} + A_2 (\text{Distance of its C.G. from Y-Y})^2$   
 $= \frac{\pi}{64} \times 80^4 + 5026.5 (83.73 - 60)^2$   
 $= 2.01 \times 10^6 + 2.83 \times 10^6$   
 $= 4.84 \times 10^6$

Hence substituting these values in equation (iv), we get

$I_{yy} = 687.05 \times 10^5 - 4.84 \times 10^6 = 63.865 \times 10^6 \text{ mm}^4$

The resultant stress at any point is obtained from equation (9.3).

$$\therefore \text{Resultant stress} = \frac{P}{A} \pm \frac{M_y \cdot x}{I_{yy}} \pm \frac{M_x \cdot y}{I_{xx}}$$

The values of  $x$  and  $y$  are taken to be positive on the same side of  $X-X$  and  $Y-Y$  as the load. Here  $O$  is the origin. Hence at point  $D$ ,  $x$  and  $y$  are positive. At point  $B$ ,  $x$  and  $y$  are both negative. At point  $C$ ,  $x$  is negative whereas  $y$  is positive.

At point  $A$ ,  $x$  is positive whereas  $y$  is negative.

(i) At point  $A$ ,  $x = 83.73$  mm and  $y = -100$  mm. Hence resultant stress at  $A$ ,

$$\begin{aligned} \sigma_A &= \frac{P}{A} + \frac{M_y \times 83.73}{I_{yy}} + \frac{M_x \times (-100)}{I_{xx}} \\ &= \frac{100000}{26973.5} + \frac{2.373 \times 10^6 \times 83.73}{63.865 \times 10^6} - \frac{5 \times 10^6 \times 100}{104.56 \times 10^6} \\ &= 3.707 + 3.111 - 4.781 \\ &= \mathbf{2.037 \text{ N/mm}^2}. \text{ Ans.} \end{aligned}$$

(ii) At point  $B$ ,  $x = -76.27$  and  $y = -100$  mm. Hence resultant stress at  $B$ ,

$$\begin{aligned} \sigma_B &= \frac{P}{A} + \frac{M_y \times (-76.27)}{I_{yy}} + \frac{M_x \times (-100)}{I_{xx}} \\ &= \frac{100000}{26973.5} - \frac{2.373 \times 10^6 \times 76.27}{63.865 \times 10^6} - \frac{5 \times 10^6 \times 100}{104.56 \times 10^6} \\ &= 3.707 - 2.833 - 4.781 \\ &= \mathbf{-3.907 \text{ N/mm}^2}. \text{ Ans.} \end{aligned}$$

(iii) At point  $C$ ,  $x = -76.27$  and  $y = 100$  mm. Hence resultant stress at  $C$ ,

$$\begin{aligned} \sigma_C &= \frac{P}{A} + \frac{M_y \times (-76.27)}{I_{yy}} + \frac{M_x \times 100}{I_{xx}} \\ &= 3.707 - 2.833 + 4.781 \\ &= \mathbf{5.655 \text{ N/mm}^2}. \text{ Ans.} \end{aligned}$$

(iv) At point  $D$ ,  $x = 83.73$  and  $y = 100$  mm. Hence resultant stress at  $D$ ,

$$\begin{aligned} \sigma_D &= \frac{P}{A} + \frac{M_y (83.73)}{I_{yy}} + \frac{M_x \times 100}{I_{xx}} \\ &= 3.707 + 3.111 + 4.781 \\ &= \mathbf{11.599 \text{ N/mm}^2}. \text{ Ans.} \end{aligned}$$

### 9.6. MIDDLE THIRD RULE FOR RECTANGULAR SECTIONS [i.e., KERNEL OF SECTION]

The cement concrete columns are weak in tension. Hence the load must be applied on these columns in such a way that there is no tensile stress anywhere in the section. But when an eccentric load is acting on a column, it produces direct stress as well as bending stress. The resultant stress at any point in the section is the algebraic sum of the direct stress and bending stress.

Consider a rectangular section of width ' $b$ ' and depth ' $d$ ' as shown in Fig. 9.16. Let this section is subjected to a load which is eccentric to the axis  $Y-Y$ .

Let  $P$  = Eccentric load acting on the column

$e$  = Eccentricity of the load

$A$  = Area of the section.

Then from equation (9.2), we have the minimum stress as

$$\sigma_{min} = \frac{P}{A} \left( 1 - \frac{6 \times e}{b} \right) \quad \dots(i)$$

If  $\sigma_{min}$  is -ve, then stress will be tensile. But if  $\sigma_{min}$  is zero (or positive) then there will be no tensile stress along the width of the column.

Hence for no tensile stress along the width of the column,

$$\sigma_{min} \geq 0$$

$$\text{or} \quad \frac{P}{A} \left( 1 - \frac{6 \times e}{b} \right) \geq 0 \quad \text{or} \quad \left( 1 - \frac{6 \times e}{b} \right) \geq 0$$

$$\text{or} \quad 1 \geq \frac{6 \times e}{b} \quad \text{or} \quad \frac{b}{6} \geq e$$

$$\text{or} \quad e \leq \frac{b}{6} \quad \dots(9.4)$$

The above result shows that the eccentricity ' $e$ ' must be less than or equal to  $\frac{b}{6}$ . Hence the greatest eccentricity of the load is  $\frac{b}{6}$  from the axis  $Y-Y$ . Hence if the load is applied at any

distance less than  $\frac{b}{6}$  from the axis, on any side of the axis  $Y-Y$ , the stresses are wholly compressive. Hence the range within which the load can be applied so as not to produce any tensile stress, is *within the middle third of the base*.

Similarly, if the load had been eccentric with respect to the axis  $X-X$ , the condition that tensile stress will not occur is when the eccentricity of the load with respect to this axis  $X-X$  does not exceed  $\frac{d}{6}$ . Hence the range within which the load may be applied is within the middle third of the depth.

If it is possible that the load is likely to be eccentric about both the axis  $X-X$  and  $Y-Y$ , the condition that tensile stress will not occur is when the load is applied anywhere within the rhombus  $ABCD$  whose diagonals are  $AC = \frac{b}{3}$  and  $BD = \frac{d}{3}$  as shown in Fig. 9.16. This figure  $ABCD$  within which the load may be applied anywhere so as not to produce tensile stress in any part of the entire rectangular section, is called the *Core or Kernel* of the section. Hence the kernel of the section is the area within which the line of action of the eccentric load  $P$  must cut

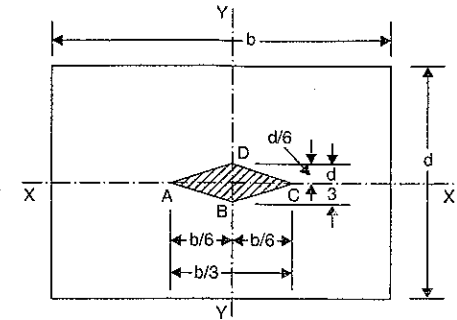

Fig. 9.16

the cross-section if the stress is not to become tensile in any part of the entire rectangular section.

- Note. (i) If direct stress ( $\sigma_0$ ) is equal to bending stress ( $\sigma_b$ ), then the tensile stress will be zero.
- (ii) If the direct stress ( $\sigma_0$ ) is more than bending stress ( $\sigma_b$ ), then the stress throughout the section will be compressive.
- (iii) If the direct stress ( $\sigma_0$ ) is less than bending stress ( $\sigma_b$ ), then there will be tensile stress.
- (iv) Hence for no tensile stress,  $\sigma_0 \geq \sigma_b$ .

**9.7. MIDDLE QUARTER RULE FOR CIRCULAR SECTIONS [i.e., KERNEL OF SECTION]**

Consider a circular section of diameter 'd' as shown in Fig. 9.17. Let this section is subjected to a load which is eccentric to the axis Y-Y.

- Let  $P$  = Eccentric load
- $e$  = Eccentricity of the load
- $A$  = Area of the section =  $\frac{\pi}{4} d^2$

Now direct stress,

$$\sigma_0 = \frac{P}{A} = \frac{P}{\frac{\pi}{4} d^2} = \frac{4P}{\pi d^2}$$

Moment,  $M = P \times e$

Bending stress ( $\sigma_b$ ) is given by,

$$\frac{M}{I} = \frac{\sigma_b}{y} \quad \text{or} \quad \sigma_b = \frac{M \times y}{I}$$

Maximum bending stress will be when

$$y = \pm \frac{d}{2}$$

\(\therefore\) Maximum bending stress is given by,

$$\sigma_b = \frac{M}{I} \times \left(\pm \frac{d}{2}\right) = \pm \frac{P \times e \times \frac{d}{2}}{\frac{\pi}{64} d^4} = \pm \frac{32 \times P \times e}{\pi d^3}$$

Now minimum stress is given by,

$$\begin{aligned} \sigma_{min} &= \sigma_0 - \sigma_b \\ &= \frac{4P}{\pi d^2} - \frac{32P \times e}{\pi d^3} \end{aligned}$$

For no tensile stress,  $\sigma_{min} \geq 0$

$$\begin{aligned} \text{or} \quad \frac{4P}{\pi d^2} - \frac{32P \times e}{\pi d^3} &\geq 0 \quad \text{or} \quad \frac{4P}{\pi d^2} \left(1 - \frac{8e}{d}\right) \geq 0 \\ \text{or} \quad 1 - \frac{8 \times e}{d} &\geq 0 \quad \text{or} \quad 1 \geq \frac{8 \times e}{d} \quad \text{or} \quad e \leq \frac{d}{8} \end{aligned} \quad \dots(9.5)$$

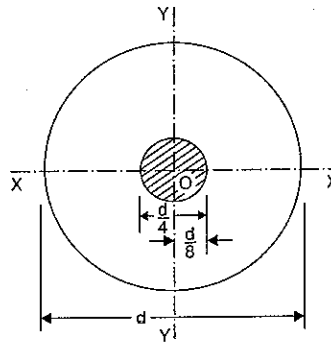

Fig. 9.17

The above result shows that the eccentricity 'e' must be less than or equal to  $\frac{d}{8}$ . It means

that the load can be eccentric, on any side of the centre of the circle, by an amount equal to  $\frac{d}{8}$ . Thus, if the line of action of the load is within a circle of diameter equal to one-fourth of the main circle as shown in Fig. 9.17, then the stress will be compressive throughout the circular section.

**9.8. KERNEL OF HOLLOW CIRCULAR SECTION (OR VALUE OF ECCENTRICITY FOR HOLLOW CIRCULAR SECTION)**

- Let  $D_0$  = External diameter, and
- $D_i$  = Internal diameter
- $P$  = Eccentric load
- $e$  = Eccentricity of the load
- $A$  = Area of section

$$= \frac{\pi}{4} [D_0^2 - D_i^2]$$

$M$  = Moment due to eccentric load  $P = P \times e$

$Z$  = Section modulus

$$= \frac{I}{y_{max}}$$

$$= \frac{\frac{\pi}{64} [D_0^4 - D_i^4]}{\left(\frac{D_0}{2}\right)} \quad \left(\because y_{max} = \frac{D_0}{2}\right)$$

$$= \frac{\pi}{32D_0} [D_0^4 - D_i^4]$$

Now direct stress ( $\sigma_0$ ) is given by

$$\sigma_0 = \frac{P}{A} \quad \dots(i)$$

The direct stress is compressive and uniform throughout the section.

Bending stress ( $\sigma_b$ ) is given by

$$\begin{aligned} \frac{M}{I} &= \frac{\sigma_b}{y} \\ \therefore \sigma_b &= \frac{M}{I} \times y = \frac{M}{\left(\frac{I}{y}\right)} \end{aligned}$$

$$= \frac{M}{Z} \quad \left(\because \frac{I}{y} = Z\right) \quad \dots(ii)$$

The bending stress may be tensile or compressive. The resultant stress at any point is the algebraic sum of direct stress and bending stress. There will be no tensile stress at any point if the bending stress is less than or equal to direct stress at that point.



Hence for no tensile stress,

$$\text{Bending stress} \leq \text{Direct stress}$$

or

$$\sigma_b \leq \sigma_o$$

Substituting the values of  $\sigma_o$  and  $\sigma_b$  from equations (i) and (ii), we get

$$\frac{M}{Z} \leq \frac{P}{A}$$

$$\frac{P \times e}{Z} \leq \frac{P}{A}$$

$$(\because M = P \times e)$$

or

$$\frac{e}{Z} \leq \frac{1}{A}$$

(cancelling P to both sides)

or

$$e \leq \frac{Z}{A} \quad \dots(9.6)$$

$$\leq \frac{\frac{\pi}{32D_0} [D_0^4 - D_i^4]}{\frac{\pi}{4} [D_0^2 - D_i^2]}$$

$$\leq \frac{4\pi (D_0^2 + D_i^2)(D_0^2 - D_i^2)}{32\pi D_0 (D_0^2 - D_i^2)}$$

$$\leq \frac{1}{8D_0} (D_0^2 + D_i^2) \quad \dots(9.7)$$

The above result shows that the eccentricity 'e' must be less than or equal to  $(D_0^2 + D_i^2)/(8D_0)$ . It means that the load can be eccentric, on any side of the centre of the circle, by an amount equal to  $(D_0^2 + D_i^2)/(8D_0)$ . Thus, if the line of action of the load is within a circle of diameter equal to  $(D_0^2 + D_i^2)/(4D_0)$ , then the stress will be compressive throughout.

$$\therefore \text{Diameter of kernel} = \frac{D_0^2 + D_i^2}{4D_0}$$

**9.9. KERNEL OF HOLLOW RECTANGULAR SECTION (OR VALUE OF ECCENTRICITY FOR HOLLOW RECTANGULAR SECTION)**

Refer to Fig. 9.17 (a).

Let B = Outer width of rectangular section

D = Outer depth

b = Internal width

d = Internal depth

A = Area of section

$$= B \times D - b \times d$$

$$I_{xx} = \frac{BD^3}{12} - \frac{bd^3}{12}$$

$$y_{max} = \frac{D}{2}$$

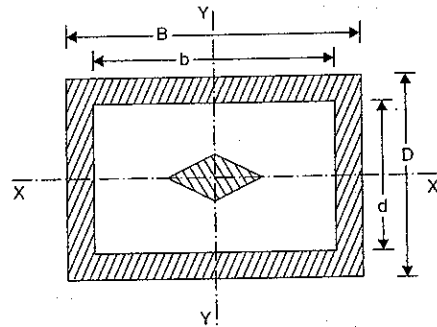

Fig. 9.17 (a)

$$\therefore Z_{xx} = \frac{I_{xx}}{y_{max}}$$

$$= \frac{\left(\frac{BD^3}{12} - \frac{bd^3}{12}\right)}{D/2} = \frac{BD^3 - bd^3}{6D}$$

Similarly,

$$Z_{yy} = \frac{I_{yy}}{x_{max}} = \frac{\frac{DB^3}{12} - \frac{db^3}{12}}{B/2} = \frac{DB^3 - db^3}{6B}$$

For no tensile stress at any section, the value of e is given by equation (9.6).

$$\therefore e \leq \frac{Z}{A} \text{ or } e_x \leq \frac{Z_{xx}}{A} \text{ and } e_y \leq \frac{Z_{yy}}{A}$$

or

$$e_x \leq \frac{\left[\frac{(BD^3 - bd^3)}{6D}\right]}{(BD - bd)} \leq \frac{(BD^3 - bd^3)}{6D(BD - bd)} \quad \dots(9.8)$$

and

$$e_y = \frac{\left(\frac{DB^3 - db^3}{6B}\right)}{(BD - bd)} = \frac{DB^3 - db^3}{6B(BD - bd)} \quad \dots[9.8 (A)]$$

It means that the load can be eccentric on either side of the geometrical axis by an amount equal to  $\frac{(BD^3 - bd^3)}{6D(BD - bd)}$  and  $\frac{DB^3 - db^3}{6B(BD - bd)}$  along x-axis and y-axis respectively.

**Problem 9.13.** Draw neat sketches of kernel of the following cross-sections :

(i) Rectangular section 200 mm × 300 mm

(ii) Hollow circular cylinder with external dia = 300 mm and thickness = 50 mm

(iii) Square with 400 cm<sup>2</sup> Area.

(Bhavnagar University, Feb. 1992)

**Sol.** Given :

(i) Rectangular Section

$$B = 200 \text{ mm}$$

$$D = 300 \text{ mm}$$

Value of 'e' for no tensile stress along width is given by equation (9.4) as

$$e \leq \frac{B}{6} \leq \frac{200}{6} \leq 33.33 \text{ cm}$$

Hence take OA = OC = 33.33 cm

The value of 'e' for no tensile stress along the depth is given by,

$$e \leq \frac{D}{3} \leq \frac{300}{3} \leq 100 \text{ cm}$$

Hence take OD = OB = 100 cm

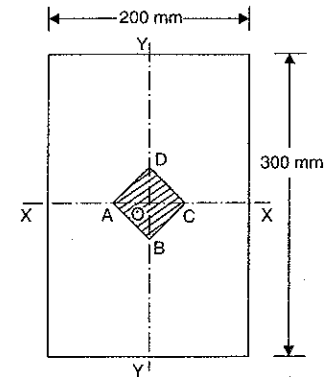

Fig. 9.18

Now join *A* to *B*, *B* to *C*, *C* to *D* and *D* to *A*. The figure *ABCD* represents the kernel of the given rectangular section as shown in Fig. 9.18.

(ii) Kernel for Hollow Circular Section

Given :

- External dia.,  $D_o = 300 \text{ m}$
- Thickness,  $t = 50 \text{ mm}$
- $\therefore$  Internal dia.,  $D_i = D_o - 2 \times t$   
 $= 300 - 2 \times 50 = 200 \text{ mm}$

For hollow cylindrical section, for no tensile stress, the value of *e* is given by equation (9.7) as

$$e \leq \frac{1}{8D_o} (D_o^2 + D_i^2)$$

$$\leq \frac{1}{8 \times 300} (300^2 + 200^2)$$

$$\leq \frac{1}{2400} (90000 + 40000)$$

$$\leq \frac{130000}{2400} \leq 54.16 \text{ mm}$$

Taking *O* as centre and radius equal to 54.16 mm (or dia. =  $2 \times 54.16 = 108.32 \text{ mm}$ ) draw a circle. This circle is the kernel of the hollow circular section of external dia. = 300 mm and internal dia. = 200 mm, as shown in Fig. 9.19.

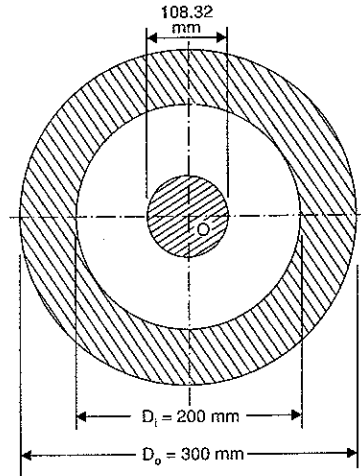

Fig. 9.19

(iii) Kernel for Square Section

Given :

- Area =  $400 \text{ cm}^2$
- $\therefore$  One side of square =  $\sqrt{400} = 20 \text{ cm}$

For no tensile stress, the value of 'e' for the square section is given by equation (9.4) as

$$e \leq \frac{\text{Side}}{6} [B \text{ or } D] \leq \frac{20}{6} \leq 3.33 \text{ cm}$$

Hence take  $OA = OC = OB = OD = 3.33 \text{ cm}$

Join *ABCD* as shown in Fig. 9.20. Then *ABCD* is the kernel of given square section.

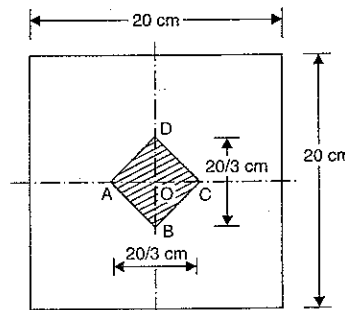

Fig. 9.20

**Problem 9.14.** Draw neat sketch of kernel of a hollow rectangular section of outer cross-section  $300 \text{ mm} \times 200 \text{ mm}$  and inner cross-section  $150 \text{ mm} \times 100 \text{ mm}$ .

**Sol.** Given :

- Outer rectangular section,  $B = 300 \text{ mm}$ ,  $D = 200 \text{ mm}$
- Inner rectangular section,  $b = 150 \text{ mm}$  and  $d = 100 \text{ mm}$ .

For no tensile stress the value of 'e' along *x*-axis and along *y*-axis are given by equations (9.8) and (9.8 A) respectively.

Using equation (9.8), we get

$$e_x \leq \frac{(BD^3 - bd^3)}{6D(BD - bd)}$$

$$= \frac{(300 \times 200^3 - 150 \times 100^3)}{6 \times 200(300 \times 200 - 150 \times 100)} = \frac{100^3 \times (2400 - 150)}{12 \times 100^3 \times (6 - 1.5)}$$

$$= \frac{2250}{12 \times 4.5} = 41.67 \text{ mm}$$

Hence take  $OA = OC = 41.67 \text{ mm}$  in Fig. 9.21

Using equation (9.8 A), we get

$$e_y \leq \frac{(DB^3 - db^3)}{6B(BD - bd)}$$

$$= \frac{(200 \times 300^3 - 100 \times 150^3)}{6 \times 300(300 \times 200 - 150 \times 100)}$$

$$= \frac{100^3(5400 - 337.5)}{6 \times 3 \times 10^3(6 - 1.5)}$$

$$= \frac{5062.5}{18 \times 4.5} = 62.5 \text{ mm}$$

Hence take  $OD = OB = 62.5 \text{ mm}$  in Fig. 9.21.

Now join *A* to *B*, *B* to *C*, *C* to *D* and *D* to *A*. The figure *ABCD* represents the kernel of the given hollow rectangular section.

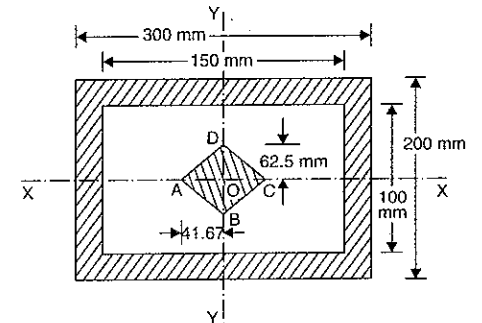

Fig. 9.21

**HIGHLIGHTS**

1. The axial load produces direct stress ( $\sigma_0$ ).
2. Eccentric load produces direct stress as well as bending stress ( $\sigma_b$ ).
3. The maximum and minimum stress at any point in a section which is subjected to a load which is eccentric to *Y*-*Y* axis is given by,

$$\sigma_{max} = \text{Direct stress} + \text{Bending stress}$$

$$= \frac{P}{A} \left( 1 + \frac{6 \times e}{b} \right) \quad \dots \text{For a rectangular section}$$

and

$$\sigma_{min} = \text{Direct stress} - \text{Bending stress}$$

$$= \frac{P}{A} \left( 1 - \frac{6 \times e}{b} \right) \quad \dots \text{For a rectangular section}$$

- where *P* = Eccentric load
- A* = Area of section
- e* = Eccentricity
- b* = Width of the section.

4. If  $\sigma_0 = \sigma_b$ , the tensile stress will be zero across the section.
5. If  $\sigma_0 > \sigma_b$ , there will be no tensile stress across the section.

6. If  $\sigma_o < \sigma_b$ , there will be tensile stress across the section.  
 7. The resultant stress at any point when a symmetrical column section is subjected to a load which is eccentric to both the axis, is given by,

$$\sigma = \frac{P}{A} \pm \frac{M_y \times x}{I_{yy}} \pm \frac{M_x \cdot y}{I_{xx}}$$

where  $P$  = Eccentric load

$A$  = Area of the section

$M_y$  = Moment of load about Y-Y axis

$I_{yy}$  = Moment of inertia about Y-Y axis

$M_x$  and  $I_{xx}$  = Moment and moment of inertia about X-X axis respectively.

The values of  $x$  and  $y$  are positive on the same side on which load is acting.

8. For unsymmetrical sections, subjected to eccentric load, first of all the C.G. of the section is determined. Then moment of inertia of the section about an axis passing through the C.G. is obtained. After that stresses are obtained.  
 9. For a rectangular section, there will be no tensile stress if the load is on either axis within the middle third of the section.  
 10. For a circular section of diameter ' $d$ ', there will be no tensile stress if the load lies in a circle of diameter  $\frac{d}{4}$  with centre  $O$  of the main circular section. This is known as 'middle quarter rule for circular sections'.  
 11. For no tensile stress, the value of eccentricity  $e$  is given by

$$e \leq \frac{d}{8} \quad \dots \text{For circular section}$$

$$\leq \frac{1}{8D_0} (D_o^2 + D_i^2) \quad \dots \text{For hollow circular section with } D_o \text{ as external dia. and } D_i \text{ as internal dia.}$$

$$\leq \frac{b}{6} \text{ and } \frac{d}{6} \quad \dots \text{For rectangular section}$$

$$\leq \frac{\text{One side of square}}{6} \quad \dots \text{For square section}$$

$$e_x \leq \frac{(BD^3 - bd^3)}{6D(BD - bd)} \quad \dots \text{For hollow rectangular section with } B \text{ and } D \text{ as outer width and depth and } b \text{ and } d \text{ as inner width and depth}$$

$$e_y \leq \frac{(DB^3 - db^3)}{6B(BD - bd)}$$

### EXERCISE 9

#### (A) Theoretical Questions

1. What do you mean by direct stress and bending stress ?
2. Prove that an eccentric load causes a direct stress as well as bending stress.
3. Find an expression for the maximum and minimum stresses when a rectangular column is subjected to a load which is eccentric to Y-Y axis.

4. Prove that for rectangular section subjected to eccentric load, the maximum and minimum stresses are given by :

$$\sigma_{max} = \frac{P}{A} \left( 1 + \frac{6e}{b} \right) \quad \text{and} \quad \sigma_{min} = \frac{P}{A} \left( 1 - \frac{6e}{b} \right)$$

where  $P$  = Eccentric load,

$A$  = Area of the system,

$b$  = Width of section,

and  $e$  = Eccentricity.

5. How will you find the maximum and minimum stresses at the base of a symmetrical column, when it is subjected to load which is eccentric to both axis ?
6. Find an expression for the maximum and minimum stresses at the base of an unsymmetrical column which is subjected to an eccentric load.
7. What do you mean by the following terms :  
 (i) Middle third rule for rectangular sections, and  
 (ii) Middle quarter rule for circular sections.
8. Prove that for no tension at the base of a short column :  
 (i) of rectangular section, the line of action of the load should be within the middle third, and  
 (ii) of circular section, the line of action of the load should be within the middle quarter.
9. Draw neat sketches of Kernel of the following cross-sections :  
 (i) Rectangular 200 mm  $\times$  300 mm  
 (ii) Hollow circular cylinder with external dia. = 300 mm, thickness = 50 mm.  
 (iii) Square with 400 cm<sup>2</sup> area. (Bhavnagar University, Feb. 1992)

#### (B) Numerical Problems

1. A rectangular column of width 120 mm and of thickness 100 mm carries a point load of 120 kN at an eccentricity of 10 mm. Determine the maximum and minimum stresses at the base of the column. [Ans. 15 N/mm<sup>2</sup>, 5 N/mm<sup>2</sup>]
2. If in the above problem, the minimum stress at the base of the section is given as zero then find the eccentricity of the point load of 120 kN acting on the rectangular section. Also calculate the corresponding maximum stress on the section. [Ans. 20 mm, 20 N/mm<sup>2</sup>]
3. If in Q. 1, the eccentricity is given as 30 mm, then find the maximum and minimum stress on the section. Also plot these stress along the width of the section. [Ans. - 5 N/mm<sup>2</sup>, 25 N/mm<sup>2</sup>]
4. In a tension specimen 13 mm in diameter the line of pull is parallel to the axis of the specimen but is displaced from it. Determine the distance of the line of pull from the axis, when the maximum stress is 15% greater than the mean stress on a section normal to the axis. [Ans. 0.25 mm]
5. A hollow rectangular column is having external and internal dimensions as 120 cm deep  $\times$  80 cm wide and 90 cm deep  $\times$  50 cm wide respectively. A vertical load of 200 kN is transmitted in the vertical plane bisecting 120 cm side and at an eccentricity of 10 cm from the geometric axis of the section. Calculate the maximum and minimum stresses in the section. [Ans. 0.61 N/mm<sup>2</sup> and 0.17 N/mm<sup>2</sup>]
6. A short column of diameter 40 cm carries an eccentric load of 80 kN. Find the greatest eccentricity which the load can have without producing tension on the cross-section. [Ans. 5 cm]
7. A short column of external diameter 50 cm and internal diameter 30 cm carries an eccentric load of 100 kN. Find the greatest eccentricity which the load can have without producing tension on the cross-section. [Ans. 8.5 cm]

8. A hollow circular column of 25 cm external and 20 cm internal diameter respectively carries an axial load of 200 kN. It also carries a load of 100 kN on a bracket whose line of action is 20 cm from the axis of the column. Determine the maximum and minimum stress at the base section.  
[Ans. 39 N/mm<sup>2</sup> (comp.), 5.13 N/mm<sup>2</sup> (tension)]
9. A column section 30 cm external diameter and 15 cm internal diameter supports an axial load of 2.6 MN and an eccentric load of  $PN$  at an eccentricity of 40 cm. If the compressive and tensile stresses are not to exceed 140 N/mm<sup>2</sup> and 60 N/mm<sup>2</sup> respectively, find the magnitude of load  $P$ .  
[Ans. 766.8 kN]
10. A rectangular pier of 1.5 m  $\times$  1.0 m is subjected to a compressive load of 450 kN as shown in Fig. 9.18. Find the stresses on all four corners of the pier.  
[Ans.  $\sigma_A = 0.45$  N/mm<sup>2</sup>,  $\sigma_B = +0.15$  N/mm<sup>2</sup>,  $\sigma_C = 1.05$  N/mm<sup>2</sup>,  $\sigma_D = 0.45$  N/mm<sup>2</sup>]

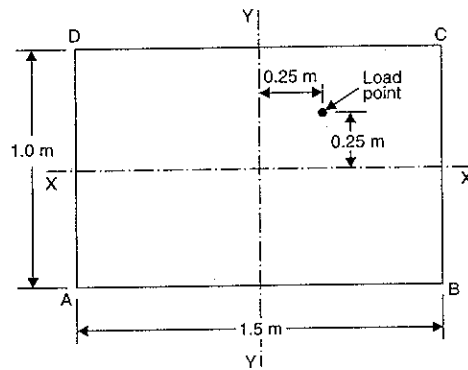

Fig. 9.22

# 10

## Dams and Retaining Walls

### 10.1. INTRODUCTION

A large quantity of water is required for irrigation and power generation throughout the year. A dam is constructed to store the water. A retaining wall is constructed to retain the earth in hilly areas. The water stored in a dam, exerts pressure force on the face of the dam in contact with water. Similarly, the earth, retained by a retaining wall, exerts pressure on the retaining wall. In this chapter, we shall study the different types of dams, stresses across the section of a dam, stability of a dam and minimum bottom width required for a dam section.

### 10.2. TYPES OF DAMS

There are many types of dams, but the following types of dams are more important :

1. Rectangular dams
2. Trapezoidal dams having
  - (a) Water face vertical, and
  - (b) Water face inclined.

A trapezoidal dam as compared to rectangular dam is economical and easier to construct. Hence these days trapezoidal dams are mostly constructed.

### 10.3. RECTANGULAR DAMS

Fig. 10.1 shows a rectangular dam having water on one of its sides.

Let  $h$  = Height of water

$F$  = Force exerted by water on the side of the dam

$W$  = Weight of dam per metre length of dam

$H$  = Height of dam

$b$  = Width of dam

$w_0$  = Weight density of dam.

Consider one metre length of the dam.

The forces acting on the dam are

(i) The force  $F$  due to water in contact with the side of the dam.

The force  $F^*$  is given by

$$F = wA\bar{h}$$

\*The derivation for  $F$  can be seen in any standard book of Fluid Mechanics.

$$= w \times (h \times 1) \times \frac{h}{2} \quad \left( \because A = h \times 1 \text{ and } \bar{h} = \frac{h}{2} \right)$$

$$= \frac{w \times h^2}{2}$$

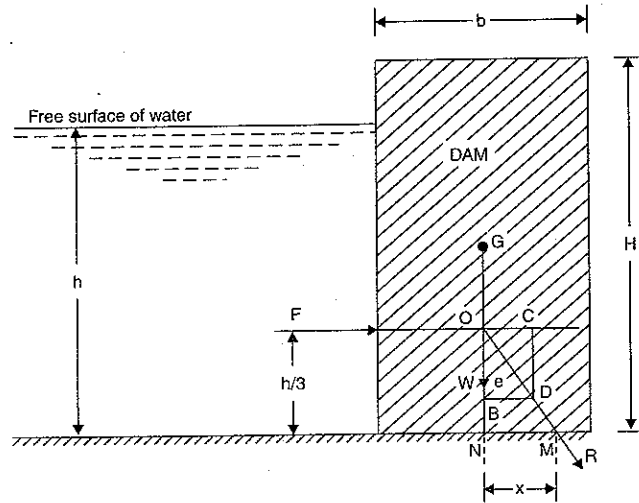

Fig. 10.1

The force  $F$  will be acting horizontally at a height of  $\frac{h}{3}$  above the base as shown in

Fig. 10.1.

(ii) The weight  $W$  of the dam. The weight of the dam is given by

$$W = \text{Weight density of dam} \times \text{Volume of dam}$$

$$= w_0 \times [\text{Area of dam}] \times 1 \quad [\because \text{Length of dam} = 1 \text{ m}]$$

$$= w_0 \times b \times H$$

The weight  $W$  will be acting downwards through the C.G. of the dam as shown in Fig. 10.1.

These are only two forces acting on the dam. The resultant force may be determined by the method of parallelogram of forces as shown in Fig. 10.1. The force  $F$  is produced to intersect the line of action of the  $W$  at  $O$ . Take  $OC = F$  and  $OB = W$  to some scale. Complete the rectangle  $OBDC$ . Then the diagonal  $OD$  will represent the resultant  $R$  to the same scale.

$$\therefore \text{Resultant } R = \sqrt{F^2 + W^2} \quad \dots(10.1)$$

And the angle made by the resultant with vertical is given by

$$\tan \theta = \frac{BD}{OB} = \frac{F}{W} \quad \dots(10.2)$$

**10.3.1. The Horizontal Distance between the Line of Action of  $W$  and the Point through which the Resultant Cuts the Base.** In Fig. 10.1 the diagonal  $OD$  represents the

resultant of  $F$  and  $W$ . Let the diagonal  $OD$  is extend so that it cuts the base of the dam at point  $M$ . Also extend the line  $OB$  so that it cuts the base at point  $N$ . Then the distance  $MN$  is the horizontal distance between the line of action of  $W$  and the point through the resultant cuts the base.

Let  $x = \text{Distance } MN$

The distance  $x$  is obtained from similar triangles  $OBD$  and  $ONM$  as given below

$$\text{i.e., } \frac{NM}{ON} = \frac{BD}{OB}$$

$$\text{or } \frac{x}{(h/3)} = \frac{F}{W} \quad (\because \text{Distance } ON = h/3, BD = OC = F \text{ and } OB = W)$$

$$\therefore x = \frac{F}{W} \times \frac{h}{3} \quad \dots(10.3)$$

The distance  $x$  can also be calculated by taking moments of all forces (here the forces  $F$  and  $W$ ) about the point  $M$ .

$$\therefore F \times \frac{h}{3} = W \times x$$

$$\therefore x = \frac{F}{W} \times \frac{h}{3}$$

**Problem 10.1.** A masonry dam of rectangular section, 20 m high and 10 m wide, has water upto a height of 16 m on its one side. Find :

- (i) Pressure force due to water on one metre length of the dam,
- (ii) Position of centre of pressure, and
- (iii) The point at which the resultant cuts the base.

Take the weight density of masonry = 19.62 kN/m<sup>3</sup>, and of water = 9.81 kN/m<sup>3</sup>.

**Sol.** Given :

- Height of dam,  $H = 20 \text{ m}$
- Width of dam,  $b = 10 \text{ m}$
- Height of water,  $h = 16 \text{ m}$
- Weight density of masonry,

$$w_0 = 19.62 \text{ kN/m}^3 = 19620 \text{ N/m}^3$$

For water,

$$w = 9.81 \text{ kN/m}^3 = 9.81 \times 1000 \text{ N/m}^3$$

(i) Pressure force due to water on one metre length of dam

Let  $F = \text{Pressure force due to water}$

$$\text{Then } F = wA\bar{h}$$

$$= 9.81 \times 1000 \times (h \times 1) \times \frac{h}{2}$$

$$(\because w \text{ for water} = 9.81 \text{ kN/m}^3 = 9.81 \times 1000 \text{ N/m}^3)$$

$$= 9.81 \times 1000 \times (16 \times 1) \times \frac{16}{2} = 1255680 \text{ N. Ans.}$$

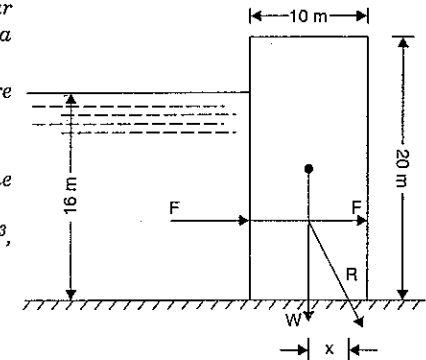

Fig. 10.2

(ii) *Position of centre of pressure*

The point, at which the force  $F$  is acting, is known as centre of pressure. The force  $F$  is acting horizontally at a height of  $\frac{h}{3}$  (i.e.,  $\frac{16}{3} = 5.33$  m) above the base.

∴ Position of centre of pressure from base = 5.33 m. Ans.

(iii) *The point at which the resultant cuts the base*

Let  $x$  = Horizontal distance between the line of action of  $W$  and the point through which the resultant cuts the base

$W$  = Weight of dam per metre length of dam  
 = Weight density of masonry  $\times$  (Area of dam)  $\times$  1  
 =  $w_0 \times b \times H \times 1 = 19620 \times 10 \times 20 \times 1 = 3924000$  N

Using equation (10.3),

$$x = \frac{F}{W} \times \frac{h}{3} = \frac{1255680}{3924000} \times \frac{16}{3} = 1.706 \text{ m. Ans.}$$

**Problem 10.2.** A masonry dam of rectangular cross-section 10 m high and 5 m wide has water upto the top on its one side. If the weight density of masonry is 21.582 kN/m<sup>3</sup>. Find :

- (i) Pressure force due to water per metre length of the dam
- (ii) Resultant force and the point at which it cuts the base of the dam.

**Sol.** Given :

Height of dam,  $H = 10$  m  
 Width of dam,  $b = 5$  m  
 Height of water,  $h = 10$  m  
 Weight density of masonry  
 $w_0 = 21.582$  kN/m<sup>3</sup>  
 = 21582 kN/m<sup>3</sup>.

(i) Pressure force due to water is given by

$$F = wA\bar{h} = 9.81 \times 1000 \times (10 \times 1) \times \frac{10}{2} = 490500 \text{ N. Ans.}$$

(ii) Resultant force is given by equation (10.1).

$$R = \sqrt{F^2 + W^2} \quad \dots(i)$$

where  $W$  = Weight of masonry dam

= Weight density of masonry  $\times$  Area of dam  $\times$  1  
 =  $w_0 \times b \times H \times 1 = 21582 \times (10 \times 5) \times 1 = 1079100$  N.

Substituting the values of  $F$  and  $W$  in equation (i), we get

$$R = \sqrt{490500^2 + 1079100^2} = 1185048 \text{ N} = 1.185 \text{ MN. Ans.}$$

**The point at which the resultant cuts the base**

Let  $x$  = Horizontal distance between the line of action of  $W$  and the point through which the resultant cuts the base.

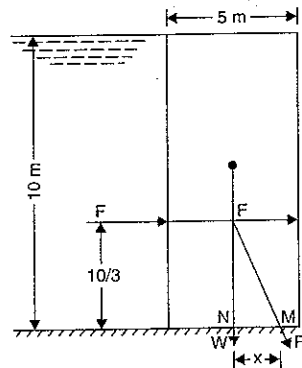

Fig. 10.3

Using equation (10.3),

$$x^* = \frac{F}{W} \times \frac{h}{3} = \frac{490500}{1079100} \times \frac{10}{3} = 1.51 \text{ m. Ans.}$$

**10.4. STRESSES ACROSS THE SECTION OF A RECTANGULAR DAM**

Fig. 10.4 shows a rectangular dam of height  $H$  and width  $b$ .

The dam is having water upto a depth of  $h$ . The forces acting on dam are

(i) The force  $F$  due to water at a height

of  $\frac{h}{3}$  above the base of the dam,

(ii) The weight  $W$  of the dam at the C.G. of the dam.

The resultant force  $R$  is cutting the base of the dam at the point  $M$  as shown in Fig. 10.4.

Let  $x$  = The horizontal distance between the line of action of  $W$  and the point through which the resultant ( $R$ ) cuts the base (i.e., distance  $MN$  in Fig. 10.4). This distance is given by equation (10.3).

$$= \frac{F}{W} \times \frac{h}{3}$$

$d$  = The distance between  $A$  and the point  $M$ , where the resultant  $R$  cuts the base

= Distance  $AM = AN + NM$

$$= \frac{b}{2} + \frac{F}{W} \times \frac{h}{3}$$

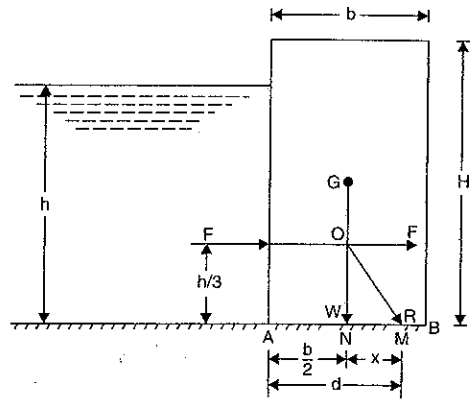

Fig. 10.4

(∵ Distance  $AN$  = Half the width of dam)

The resultant  $R$  meets the base of the dam at point  $M$ . This resultant force  $R$  acting at  $M$  may be resolved into vertical and horizontal components. The vertical component will be equal to  $W$  whereas the horizontal component will be equal to  $F$  as shown in Fig. 10.4 (a). The vertical component  $W$  acting at point  $M$  on the base of the dam is an eccentric load as it is not acting at the middle of the base. The point  $N$  in Fig. 10.4 for a rectangular dam is the middle point of the base.

But an eccentric load produces direct stress and bending stress as mentioned in chapter 9.

∴ Eccentricity of the vertical component  $W$  is equal to distance  $NM$  which is equal to  $x$  in this case.

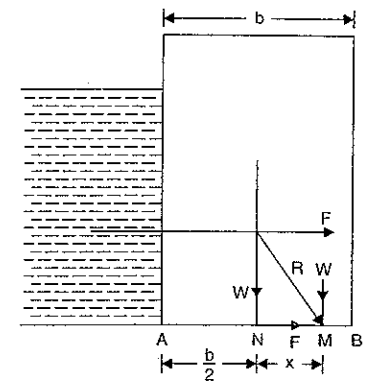

Fig. 10.4 (a)

\* $x$  can also be obtained by taking moments of all forces (i.e., force  $F$  and  $W$ ) about the point  $M$ .

$$\therefore F \times \frac{10}{3} = W \times x \text{ or } x = \frac{F}{W} \times \frac{10}{3} = \frac{490500}{1079100} \times \frac{10}{3} = 1.51 \text{ m.}$$

$$\therefore \text{Eccentricity, } e = \text{Distance } x \text{ (or Distance } NM) \quad \dots(10.4)$$

$$= AM - AN = d - \frac{b}{2} \quad \dots(10.5)$$

Due to the eccentricity, there will be a moment on the base of the dam. This moment will cause some bending stresses at the base section of the dam.

Now the moment on the base section

$$= W \times \text{Eccentricity}$$

$$= W.e$$

$$\therefore \text{Moment, } M = W.e$$

$$\text{We know that } \frac{M}{I} = \frac{\sigma_b}{y} \quad \dots(i)$$

where  $M = \text{Moment}$

$I = \text{Moment of inertia}$

$$= \frac{1 \times b^3}{12}$$

$$= \frac{b^3}{12}$$

$\sigma_b = \text{Bending stress at a distance } y \text{ from the centre of gravity of the base section}$   
 $y = \text{Distance between the C.G. of the base section and extreme edge of the abse (which$

is equal to  $\pm \frac{b}{2}$  in this case).

Substituting the values in equation (i), we get

$$\frac{W.e}{(b^3/12)} = \frac{\sigma_b}{(\pm b/2)}$$

$$\therefore \sigma_b = \pm W.e \frac{b}{2} \times \frac{12}{b^3} = \pm \frac{6W.e}{b^2}$$

The bending stress across base at point B (see Fig. 10.4)

$$= \frac{6W.e}{b^2}$$

And the bending stress across base at point A

$$= -\frac{6W.e}{b^2}$$

But the direct stress on the base section due to direct load is given by

$$\sigma_0 = \frac{\text{Weight of dam}}{\text{Area of base}} = \frac{W}{b \times 1} = \frac{W}{b}$$

$\therefore$  Total stress across the base at B

$$\sigma_{max} = \sigma_0 + \sigma_b = \frac{W}{b} + \frac{6W.e}{b^2} = \frac{W}{b} \left( 1 + \frac{6.e}{b} \right) \quad \dots(10.6)$$

and total stress across the base at A,

$$\sigma_{min} = \sigma_0 + \text{Bending stress at point A}$$

$$= \frac{W}{b} - \frac{6W.e}{b^2}$$

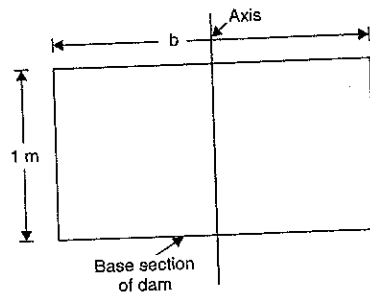

Fig. 10.5

$$= \frac{W}{b} \left( 1 - \frac{6.e}{b} \right) \quad \dots(10.7)$$

If the value of  $\sigma_{min}$  is negative, this means that at the point A the stress is tensile.

**Problem 10.3.** For the Problem 10.1, find the maximum and minimum stress intensities at the base of the dam.

**Sol.** The data given for Problem 10.1 is

$$H = 20 \text{ m, } b = 10 \text{ m, } h = 16 \text{ m, } w_0 = 19620 \text{ N/m}^3$$

The force calculated are

$$F = 1255680 \text{ N, } W = 3924000 \text{ N}$$

And distance,  $x = 1.706 \text{ m.}$

From equation (10.4), we know

$$\text{Eccentricity, } e = \text{Distance } x = 1.706 \text{ m}$$

$$(\because x = 1.706 \text{ m})$$

**Maximum stress at the base of the dam (i.e.,  $\sigma_{max}$ )**

Using equation (10.6), we have

$$\sigma_{max} = \frac{W}{b} \left( 1 + \frac{6.e}{b} \right) = \frac{3924000}{10} \left( 1 + \frac{6 \times 1.706}{10} \right)$$

$$= 392400 (1 + 1.0236)$$

$$= 794060.64 \text{ N/m}^2 = 0.794 \text{ N/mm}^2 \text{ (compressive). Ans.}$$

**Minimum stress at the base of the dam (i.e.,  $\sigma_{min}$ )**

Using equation (10.7), we get

$$\sigma_{min} = \frac{W}{b} \left( 1 - \frac{6.e}{b} \right) = \frac{3924000}{10} \left( 1 - \frac{6 \times 1.706}{10} \right)$$

$$= 392400 (1 - 1.0236) = -9260.64 \text{ N/m}^2$$

$$= 0.00926 \text{ N/mm}^2 \text{ (Tensile). Ans.}$$

**Problem 10.4.** For the Problem 10.2, find the maximum and minimum stress intensities at the base of the dam.

**Sol.** The data given for Problem 10.2 is

$$H = h = 10 \text{ m, } b = 5 \text{ m and } w_0 = 21582 \text{ N/m}^3$$

Calculated values are

$$F = 490500 \text{ N, } W = 1079100 \text{ N, } x = 1.51 \text{ m.}$$

From equation (10.4), we know

$$\text{Eccentricity, } e = x = 1.51 \text{ m.}$$

**Maximum stress at the base of the dam (i.e.,  $\sigma_{max}$ )**

Using equation (10.7), we have

$$\sigma_{max} = \frac{W}{b} \left( 1 + \frac{6.e}{b} \right) = \frac{1079100}{5} \left( 1 + \frac{6 \times 1.51}{5} \right) = 215820 (1 + 1.812)$$

$$= 606885.84 \text{ N/m}^2 \text{ (compressive). Ans.}$$

**Minimum stress at the base of the dam (i.e.,  $\sigma_{min}$ )**

Using equation (10.7), we have

$$\sigma_{min} = \frac{W}{b} \left( 1 - \frac{6.e}{b} \right) = \frac{1079100}{5} \left( 1 - \frac{6 \times 1.51}{5} \right)$$

$$= 215820 (2 - 1.812) = -175245.84 \text{ N/m}^2$$

$$= 175245 \text{ N/m}^2 \text{ (tensile). Ans.}$$

**10.4.1. Trapezoidal Dam having Water Face Vertical.** Fig. 10.6 shows a trapezoidal dam having water face vertical. Consider one metre length of the dam.

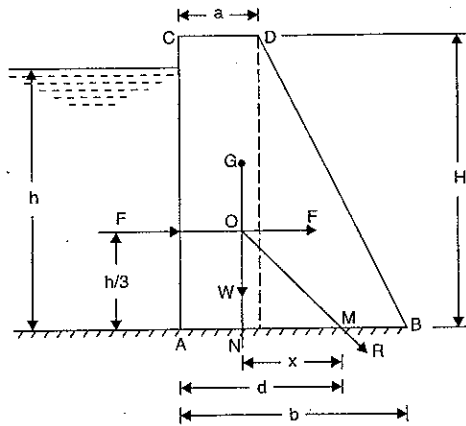

Fig. 10.6

Let  $H$  = Height of dam

$h$  = Height of water,

$a$  = Top width of dam,

$b$  = Bottom width of dam,

$w_0$  = Weight density of dam masonry,

$w$  = Weight density of water =  $\rho \times g = 1000 \times 9.81 \text{ N/m}^3$   
 $= 9.81 \text{ kN/m}^3 = 9810 \text{ N/m}^3$

$F$  = Force exerted by water

$W$  = Weight of dam per metre length of dam.

Now the forces acting on the dam are

(i)  $F$  = Force exerted by water

$$= w \times A \times \bar{h} = w \times (h \times 1) \times \frac{h}{2} = w \times \frac{h^2}{2}$$

The force  $F$  will be acting horizontally at a height of  $h/3$  above the base.

(ii)  $W$  = Weight of dam per metre length of dam

= Weight density of dam  $\times$  (Area of cross-section)  $\times 1$

$$= w_0 \times \left( \frac{a+b}{2} \right) \times H \times 1 \quad [\because \text{Area} = \frac{1}{2} (\text{Sum of parallel sides}) \times \text{Height}]$$

$$= w_0 \times \frac{(a+b)}{2} \times H$$

The weight  $W$  will be acting downwards through the C.G. of the dam.

(i) The distance of the C.G. of the trapezoidal section (shown in Fig. 10.6) from the vertical face  $AC$  is obtained by splitting the dam section into a rectangle and a triangle, taking the moments of their areas about line  $AC$  and equating the same with the moment of the total area of the trapezoidal section about the line  $AC$ .

i.e., Area of rectangle  $\times$  Distance of C.G. of rectangle from  $AC$  + Area of triangle  $\times$  Distance of C.G. of triangle from  $AC$  = Total area of trapezoidal  $\times$  Distance  $AN$

$$\text{or} \quad (a \times H) \times \frac{a}{2} + \frac{(b-a) \times H}{2} \left( a + \frac{b-a}{3} \right) = \left( \frac{a+b}{2} \right) \times H \times AN$$

From the above equation distance  $AN$  can be calculated.

(ii) The distance  $AN$  can also be calculated by using the relation given below.

$$AN = \frac{a^2 + ab + b^2}{3(a+b)} \quad \dots(10.8)$$

Now let  $x^*$  = Horizontal distance between the line of action of weight of dam and the point where the resultant cuts the base

= Distance  $MN$  and it is given by equation (10.3)

$$= \frac{F}{W} \times \frac{h}{3}$$

$d$  = Distance between  $A$  and the point  $M$  where the resultant cuts the base (i.e., distance  $AM$ )

$$= AN + NM$$

...(10.9)

The distances  $AN$  and  $NM$  can be calculated and hence the distance ' $d$ ' will be known.

Now the eccentricity,  $e = d - \text{half the base width of the dam}$

$$= d - \frac{b}{2}$$

Then the total stress across the base of the dam at point  $B$ ,

$$\sigma_{max} = \frac{W}{b} \left( 1 + \frac{6.e}{b} \right) \quad \dots(10.10)$$

and the total stress, across the base at  $A$ ,

$$\sigma_{min} = \frac{W}{b} \left( 1 - \frac{6.e}{b} \right) \quad \dots(10.11)$$

**Problem 10.5.** A trapezoidal masonry dam is of 18 m height. The dam is having water upto a depth of 15 m on its vertical side. The top and bottom width of the dam are 4 m and 8 m respectively. The weight density of the masonry is given as 19.62 kN/m<sup>3</sup>. Determine :

(i) The resultant force on the dam per metre length.

(ii) The point where the resultant cuts the base, and

(iii) The maximum and minimum stress intensities at the base.

**Sol.** Given :

Height of dam,  $H = 18 \text{ m}$

Depth of water,  $h = 15 \text{ m}$

Top width of dam,  $a = 4 \text{ m}$

Bottom width of dam,  $b = 8 \text{ m}$

Weight density of masonry,

$$w_0 = 19.62 \text{ kN/m}^3 = 19620 \text{ N/m}^3$$

\* The distance  $x$  can also be calculated by taking moments of all forces about the point  $M$ .

$$\therefore F \times \frac{h}{3} = W \times x \quad \therefore x = \frac{F}{W} \times \frac{h}{3}$$



**(i) Resultant force on dam**

Let us find first the force  $F$  and weight of the dam.

$$\begin{aligned} \text{Force } F &= w \times A \times \bar{h} \\ &= 9810 \times (h \times 1) \times \frac{h}{2} \\ &= 9810 \times 15 \times \frac{15}{2} = 1103625 \text{ N} \end{aligned}$$

And it is acting at a distance of  $\frac{h}{3}$  i.e.,

$$\frac{15}{3} = 5.0 \text{ m above the base.}$$

Now weight of dam is given by

$$W = \text{Weight density of masonry} \times \text{Area of dam} \times 1$$

$$\begin{aligned} &= w_0 \times \left( \frac{a+b}{2} \right) \times H \times 1 \\ &= 19620 \times \left( \frac{4+8}{2} \right) \times 18 \times 1 \text{ N} \\ &= 19620 \times 6 \times 18 = 2118960 \text{ N.} \end{aligned}$$

The distance of the line of action of  $W$  from the line  $AC$  is obtained by splitting the dam into rectangle and triangle, taking the moments of their areas about the line  $AC$  and equating to the moment of the area of the trapezoidal about the line  $AC$ .

$$\text{or } 4 \times 18 \times 2 + \frac{4 \times 18}{2} \times \left( 4 + \frac{1}{3} \times 4 \right) = \left( \frac{4+8}{2} \right) \times 18 \times AN$$

$$\text{or } 144 + 36 [5.33] = 108 \times AN$$

$$\therefore AN = \frac{144 + 36 \times 5.33}{108} = 3.11 \text{ m.}$$

$AN$  can also be calculated as given by equation (10.8)

$$\begin{aligned} \therefore AN &= \frac{a^2 + ab + b^2}{3(a+b)} = \frac{4^2 + 4 \times 8 + 8^2}{3(4+8)} \quad (\because a = 4 \text{ m and } b = 8 \text{ m}) \\ &= \frac{16 + 32 + 64}{36} = \frac{112}{36} = 3.11 \text{ m.} \end{aligned}$$

The resultant force  $R$  is given by

$$\begin{aligned} R &= \sqrt{F^2 + W^2} = \sqrt{1103625^2 + 2118960^2} \\ &= 238925.5 \text{ N} = \mathbf{2.389 \text{ MN.}} \quad \text{Ans.} \end{aligned}$$

**(ii) The point where the resultant cuts the base**

Let  $x$  = The horizontal distance between the line of action of  $W$  and the point at which the resultant cuts the base.

Using equation (10.3), we get

$$x = \frac{F}{W} \times \frac{h}{3} = \frac{1103625}{2118960} \times \frac{15}{3} = 2.604 \text{ m}$$

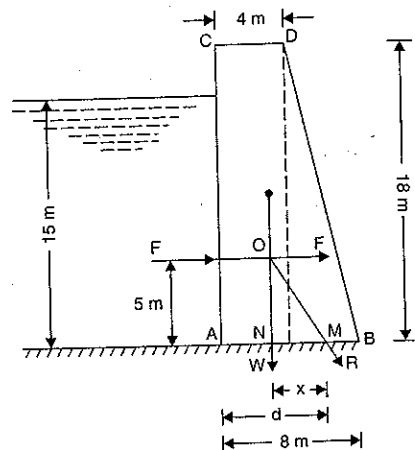

Fig. 10.7

The distance  $x$  can also be calculated by taking moments of all forces about the point  $M$ .

$$\therefore F \times 5 = W \times x$$

$$\therefore x = \frac{F}{W} \times 5 = \frac{1103625}{2118960} \times 5 = 2.604 \text{ m}$$

From Fig. 10.6, the distance  $AM = d$ .

$$\begin{aligned} \therefore d &= AN + NM \\ &= 3.11 + x = 3.11 + 2.604 = 5.714 \text{ m} \end{aligned}$$

$$\text{Now eccentricity, } e = d - \frac{b}{2}$$

$$= 5.714 - \frac{8}{2} = 5.714 - 4.0 = 1.714 \text{ m.}$$

**(iii) The maximum and minimum stress intensities**

Let  $\sigma_{max}$  = Maximum stress, and

$\sigma_{min}$  = Minimum stress

Using equation (10.10), we get

$$\begin{aligned} \sigma_{max} &= \frac{W}{b} \left[ 1 + \frac{6e}{b} \right] = \frac{2118960}{8} \left[ 1 + \frac{6 \times 1.714}{8} \right] \\ &= 264870 (1 + 1.2855) = \mathbf{605360 \text{ N/m}^2.} \quad \text{Ans.} \end{aligned}$$

Using equation (10.11), we get

$$\begin{aligned} \sigma_{min} &= \frac{W}{b} \left[ 1 - \frac{6e}{b} \right] = \frac{2118960}{8} \left[ 1 - \frac{6 \times 1.714}{8} \right] \\ &= 264870 (1 - 1.2855) = \mathbf{-75620 \text{ N/m}^2.} \quad \text{Ans.} \end{aligned}$$

-ve sign shows that stress is tensile.

**Problem 10.6.** A masonry trapezoidal dam 4 m high, 1 m wide at its top and 3 m wide at its bottom retains water on its vertical face. Determine the maximum and minimum stresses at the base :

(i) when the reservoir is full, and

(ii) when the reservoir is empty. Take the weight density of masonry as  $19.62 \text{ kN/m}^3$ .

**Sol.** Given :

Height of dam,  $H = 4 \text{ m}$

Top width of dam,  $a = 1 \text{ m}$

Bottom width of dam,  $b = 3 \text{ m}$

Depth of water,  $h = 4 \text{ m}$

Weight density of masonry,

$$w_0 = 19.62 \text{ kN/m}^3 = 19620 \text{ N/m}^3$$

Consider one metre length of dam.

(i) Where reservoir is full of water

The force exerted by water on the vertical face of the dam per metre length is given by,

$$\begin{aligned} F &= w \times A \times \bar{h} = 9810 \times (4 \times 1) \times \left( \frac{4}{2} \right) \\ &(\because w = 9810 \text{ N/m}^3 \text{ for water}) \\ &= \mathbf{78480 \text{ N}} \end{aligned}$$

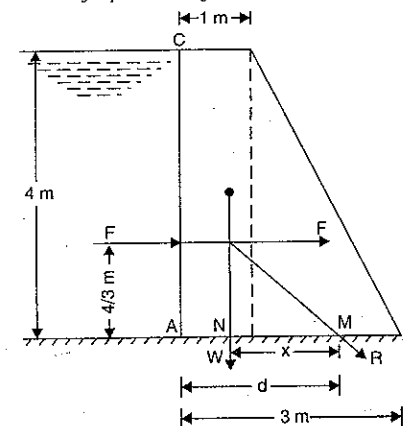

Fig. 10.8

The weight of dam per metre length is given by

$$\begin{aligned} W &= \text{Weight density of masonry dam} \times \text{Area of trapezoidal} \times 1 \\ &= w_0 \times \left( \frac{a \times b}{2} \right) \times H \\ &= 19620 \times \left( \frac{1+3}{2} \right) \times 4 = 156960 \text{ N.} \end{aligned}$$

Now let us find the position of the C.G. of the dam section. This is done by splitting the trapezoidal into rectangle and triangle, taking the moments of their areas about the line AC and equating to the moment of the area of the trapezoidal about the line AC.

$$\therefore \left( 4 \times 1 \times \frac{1}{2} \right) + \left[ \frac{4 \times 2}{2} \times \left( 1 + \frac{1}{3} \times 2 \right) \right] = \left( \frac{1+3}{2} \right) \times 4 \times AN$$

or

$$2 + 4 \times 1.67 = 8 \times AN$$

$$\therefore AN = \frac{2 + 6.68}{8} = \frac{8.68}{8} = 1.08 \text{ m}$$

AN can also be calculated from equation (10.8), as

$$\begin{aligned} AN &= \frac{a^2 + ab + b^2}{3(a+b)} \\ &= \frac{1^2 + 1 \times 3 + 3^2}{3(1+3)} = \frac{1+3+9}{12} = \frac{13}{12} = 1.08 \text{ m.} \end{aligned}$$

The horizontal distance  $x$ , between the line of action of  $W$  and the point at which the resultant cuts the base, is obtained by using equation (10.3),

$$\begin{aligned} \therefore x &= \frac{F}{W} \times \frac{h}{3} \\ &= \frac{78480}{156960} \times \frac{4}{3} = 0.67 \text{ m} \end{aligned}$$

$\therefore$  Horizontal distance  $AM$  from Fig. 10.7 is given by

$$\begin{aligned} d &= AN + x \\ &= 1.08 + 0.67 = 1.75 \text{ m} \end{aligned}$$

$$\begin{aligned} \therefore \text{Eccentricity, } e &= d - \frac{b}{2} \\ &= 1.75 - \frac{3}{2} = 1.75 - 1.50 = 0.25 \text{ m.} \end{aligned}$$

Now let  $\sigma_{max}$  = Maximum stress at the base of the dam, and  
 $\sigma_{min}$  = Minimum stress.

Using equation (10.10), we get

$$\begin{aligned} \sigma_{max} &= \frac{W}{b} \left( 1 + \frac{6e}{b} \right) \\ &= \frac{156960}{3} \left( 1 + \frac{6 \times 0.25}{3} \right) = 78480 \text{ N/m}^2. \text{ Ans.} \end{aligned}$$

Using equation (10.11), we get

$$\begin{aligned} \sigma_{min} &= \frac{W}{b} \left( 1 - \frac{6e}{b} \right) \\ &= \frac{156960}{3} \left( 1 - \frac{6 \times 0.25}{3} \right) = 26163 \text{ N/m}^2. \text{ Ans.} \end{aligned}$$

(ii) When the reservoir is empty

When the reservoir is empty, the force  $F$  exerted by water will be zero as there is no water retained by the dam. Hence only the weight of the dam will be acting as shown in Fig. 10.9.

The weight of dam,  $W = 156960$  N as before. The position of the C.G. of the dam will also remain the same.

$\therefore$  Distance  $AN = 1.08$  m as before.

Now the resultant force on the dam is equal to the weight of the dam, as force  $F$  is zero. Hence the horizontal distance at the base of dam between  $A$  and the point at which the resultant (i.e., force  $W$  in this case) cuts the base is equal to distance  $AN$ .

$\therefore d = AN = 1.08$  m.

As  $W$  is not acting at the middle of the base, this load is an eccentric load.

$$\begin{aligned} \text{Now eccentricity, } e &= d - \frac{b}{2} \\ &= 1.08 - \frac{3}{2} = 1.08 - 1.5 = -0.42 \text{ m.} \end{aligned}$$

(Minus sign only indicates that stress at  $A$  will be more than at  $B$ .)

Now using equation (10.10), we get

$$\begin{aligned} \sigma_{max} &= \frac{W}{b} \left( 1 + \frac{6e}{b} \right) \\ &= \frac{156960}{3} \left( 1 + \frac{6 \times 0.42}{3} \right) \quad (\text{Numerically } e = 0.42) \\ &= 96265 \text{ N/m}^2. \text{ Ans.} \end{aligned}$$

Using equation (10.11), we get

$$\begin{aligned} \sigma_{min} &= \frac{W}{b} \left( 1 - \frac{6e}{b} \right) \\ &= \frac{156960}{3} \left( 1 - \frac{6 \times 0.42}{3} \right) \\ &= 8367.93 \text{ N/m}^2. \text{ Ans.} \end{aligned}$$

**Problem 10.7.** A masonry dam, trapezoidal in cross-section, 4 m high, 1 m wide at its top and 3 m wide at its bottom, retains water on its vertical face to a maximum height of 3.5 m from its base. Determine the maximum and minimum stresses at the base (i) When the reservoir is empty, and (ii) When the reservoir is full. Take the unit weight of masonry as 19.62 kN/m<sup>3</sup>.

(AMIE, Summer 1988)

**Sol.** Given :

$$H = 4 \text{ m, } a = 1 \text{ m, } b = 3 \text{ m}$$

$$h = 3.5 \text{ m, } w_0 = 19.62 \text{ kN/m}^3 = 19620 \text{ N/m}^3$$

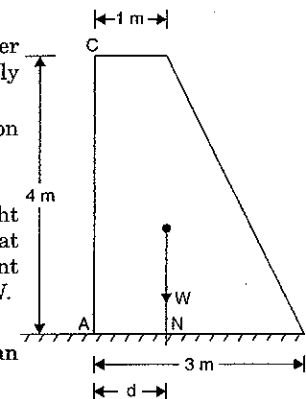

Fig. 10.9

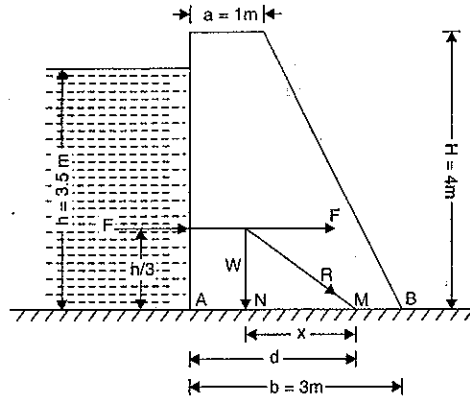

Fig. 10.9 (a)

Weight density of water,  $w = 9810 \text{ N/m}^3$

Consider 1 m length of the dam.

The force  $F$  exerted by water is given by

$$F = w \times A \times \bar{h} = 9810 \times (h \times 1) \times \frac{h}{2}$$

$$= 9810 \times (3.5 \times 1) \times \frac{3.5}{2} = 9.81 \times 6125 \text{ N} = 60086 \text{ N}$$

This force acts at a height of  $\frac{h}{3} = \frac{3.5}{3} = 1.167 \text{ m}$  above the ground.

The weight  $W$  of the dam per metre length is given by

$$W = w_0 \times \left(\frac{a+b}{2}\right) \times H \times 1$$

$$= 19620 \times \left(\frac{1+3}{2}\right) \times 4 \times 1 = 156960 \text{ N}$$

The distance of C.G. of the dam section from point A [i.e., distance  $AN$  of Fig. 10.9 (a)] is given by equation (10.8) as

$$AN = \frac{a^2 + ab + b^2}{3(a+b)} = \frac{1^2 + 1 \times 3 + 3^2}{3(1+3)}$$

$$= \frac{1+3+9}{12} = \frac{13}{12} = 1.08 \text{ m}$$

The horizontal distance 'x', between the line of action of  $W$  and the point at which the resultant cuts the base, is obtained by using equation (10.3) as

$$x = \frac{F}{W} \times \frac{h}{3} = \frac{60086}{156960} \times \frac{3.5}{3} = 0.446 \text{ m}$$

(i) *Maximum and Minimum stresses at the base when the reservoir is empty.*

When the reservoir is empty (i.e., there is no water), the only force acting on the dam will be its own weight i.e., 156960 N. The position of C.G. of the dam section will remain same.

Hence distance  $AN = 1.08 \text{ m}$ . Also the resultant force here will be  $W$  only. The distance of the point where resultant cuts the base from A will be

$$d = AN = 1.08 \text{ m}$$

Hence eccentricity 'e' is given by

$$e = d - \frac{b}{2}$$

$$= 1.08 - \frac{3}{2} = -0.42 \text{ m}$$

(Minus sign only indicates that stress at A will be more than that of at B)

The stresses are given by equation (10.10) as

$$= \frac{W}{b} \left(1 \pm \frac{6 \times e}{b}\right) = \frac{156960}{3} \left[1 \pm \frac{6 \times (-0.42)}{3}\right]$$

$$= \frac{156960}{3} \left(1 \pm \frac{6 \times 0.42}{3}\right) = 52320 (1 \pm 0.84)$$

$$\therefore \text{Maximum stress} = \sigma_{max}$$

$$= 52320 (1 + 0.84) = 52320 (1.84) \text{ N/m}^2$$

$$= 96268.8 \text{ N/m}^2. \text{ Ans.}$$

$$\text{and Minimum stress} = \sigma_{min}$$

$$= 52320 (1 - 0.84) = 52320 (0.16)$$

$$= 8371.2 \text{ N/m}^2. \text{ Ans.}$$

(ii) *Maximum and minimum stresses when reservoir is full.*

In this case, two forces i.e.,  $F$  and  $W$  are acting on the dam. The resultant ( $R$ ) of these two forces cuts the base at the point  $M$ . The distance  $AM$  is given by,

$$d = AM = AN + x$$

$$= 1.08 + 0.446 = 1.526 \text{ m}$$

Now eccentricity is obtained as

$$e = d - \frac{b}{2} = 1.526 - \frac{3}{2} = 1.526 - 1.5 = 0.026 \text{ m}$$

$\therefore$  Maximum stress is given by,

$$\sigma_{max} = \frac{W}{b} \left(1 + \frac{6 \times e}{b}\right)$$

$$= \frac{156960}{3} \left(1 + \frac{6 \times 0.026}{3}\right) = 52320 (1 + 0.052)$$

$$= 55040.64 \text{ N/m}^2. \text{ Ans.}$$

$$\text{and } \sigma_{min} = \frac{W}{b} \left(1 - \frac{6 \times e}{b}\right)$$

$$= \frac{156960}{3} \left(1 - \frac{6 \times 0.026}{3}\right) = 52320 (1 - 0.052)$$

$$= 52320 \times 0.948 = 49599.36 \text{ N/m}^2. \text{ Ans.}$$

## 10.5. TRAPEZOIDAL DAM HAVING WATER FACE INCLINED

Fig. 10.10 shows a trapezoidal dam section having its water face inclined.

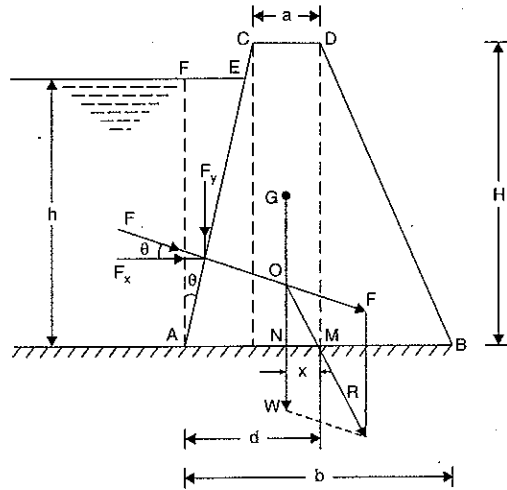

Fig. 10.10

Let  $H$  = Height of dam,

$h$  = Height of water,

$a$  = Top width of dam,

$b$  = Bottom width of dam,

$w_0$  = Weight density of dam masonry,

$w$  = Weight density of water

= 9810 N/m<sup>3</sup>

$\theta$  = Inclination of face  $AC$  with vertical,

$F$  = Force exerted by water on face  $AC$ ,

$F_x$  = Component of  $F$  in  $x$ -direction

=  $F \cos \theta$ ,

$F_y$  = Component of  $F$  in vertically downward direction

=  $F \sin \theta$ ,

$W$  = Weight of dam per metre length of dam,

=  $w_0 \times \left( \frac{a+b}{2} \right) \times H$

$L$  = Length of sloping side  $AE$  which is subjected to water pressure.

Consider one metre length of the dam.

Now in triangle  $AEF$ ,

$$\cos \theta = \frac{AF}{AE} = \frac{h}{L}$$

$$\therefore L = \frac{h}{\cos \theta} \quad \dots(i)$$

The force acting on the dam are

(i) The force exerted by water on face  $AE$  is given by,

$$F = w.A.\bar{h}$$

where  $A$  = Area of face  $AE$

$$= AE \times 1$$

( $\because$  Length of dam perpendicular to plane of paper = 1 m)

$$= \frac{h}{\cos \theta}$$

$$\bar{h} = \frac{h}{2}$$

$$\left( \because AE = L = \frac{h}{\cos \theta} \right)$$

$$\therefore F = w \times \frac{h}{\cos \theta} \times \frac{h}{2} = \frac{w \times h^2}{2 \cos \theta}$$

The force  $F$  acts perpendicular to the face  $AE$  as shown in Fig. 10.10 at a height  $\frac{h}{3}$  above the base.

Now,

$$F_x = F \times \cos \theta$$

$$= \frac{w \times h^2}{2 \cos \theta} \times \cos \theta$$

$$\left( \because F = \frac{w \times h^2}{2 \cos \theta} \right)$$

$$= \frac{w \times h^2}{2}$$

= Force exerted by water on vertical face  $AF$

and

$$F_y = F \sin \theta$$

$$= \frac{w \times h^2}{2 \cos \theta} \times \sin \theta$$

$$\left( \because F = \frac{w \times h^2}{2 \cos \theta} \right)$$

$$= \frac{w \times h^2}{2} \times \tan \theta$$

$$= \frac{w \times h^2}{2} \times \frac{EF}{AF}$$

$$\left( \because \text{In } \triangle AEF, \tan \theta = \frac{EF}{AF} \right)$$

$$= \frac{w \times h^2}{2} \times \frac{EF}{h}$$

$$\left( \because AF = h \right)$$

$$= w \times \frac{h \times EF}{2}$$

=  $w \times$  Area of triangle  $AEF$

$$\left( \because \text{Area of triangle } AEF = \frac{EF \times h}{2} \right)$$

=  $w \times$  Area of triangle  $AEF \times 1$

= Weight of water in the wedge  $AEF$ .

Hence the force  $F$ , acting on inclined face  $AE$  is equivalent to force  $F_x$  acting on the vertical face  $AF$  and force  $F_y$ , which is equal to the weight of water in the wedge  $AEF$ .

The force  $F_x$  acts at a height  $\frac{h}{3}$  above the base whereas the force  $F_y$  acts through the C.G. of the triangle  $AEF$ .

(ii) Weight of dam per metre length of the dam and it is given by

$$W = \left( \frac{a+b}{2} \right) \times H \times w_0.$$

The weight  $W$  will be acting through the C.G. of the trapezoidal section of the dam. The distance of the C.G. of the trapezoidal section shown in Fig. 10.10 from the point  $A$  is obtained by splitting the dam section into triangles and rectangle, taking the moments of their areas about the point  $A$  and equating the same with the moment of the total area of the trapezoidal section about the point  $A$ . By doing so the distance  $AN$  will be known.

(iii) The force  $R$ , which is the resultant of the forces  $F$  and  $W$ , cuts the base of the dam at point  $M$ . The distance  $AM$  can be calculated by taking moments of all forces (i.e., forces  $F_x$ ,  $F_y$  and  $W$ ) about the point  $M$ . But the distance  $AM = d$ .

Now the eccentricity,  $e = d - \frac{b}{2}$ .

Then the total stress across the base of the dam at point  $B$ ,

$$\sigma_{max} = \frac{V}{b} \left( 1 + \frac{6e}{b} \right) \quad \dots(10.12)$$

and the total stress across the base of the dam at point  $A$ ,

$$\sigma_{min} = \frac{V}{b} \left( 1 - \frac{6e}{b} \right) \quad \dots(10.13)$$

where  $V =$  Sum of the vertical forces acting on the dam  
 $= F_y + W$ .

**Problem 10.8.** A masonry dam of trapezoidal section is 10 m high. It has top width of 1 m and bottom width 7 m. The face exposed to water has a slope of 1 horizontal to 10 vertical. Calculate the maximum and minimum stresses on the base, when the water level coincides with the top of the dam. Take weight density of masonry as 19.62 kN/m<sup>3</sup>.

**Sol.** Given :

Height of dam,  $H = 10$  m

Top width of dam,  $a = 1$  m

Bottom width of dam,  $b = 7$  m

Slope of face exposed to water = 1 hor. to 10 vertical

$\therefore$  Length of  $EC$  in Fig. 10.11 = 1 m

Depth of water,  $h = 10$  m

Weight density of masonry,  $w_0 = 19.62$  kN/m<sup>3</sup> = 19620 N/m<sup>3</sup>

Consider one metre length of the dam.

Let the weight of dam ( $W$ ) cut the base at  $N$  whereas the resultant  $R$  cuts the base at  $M$ .

The force  $F$  due to water acting on the face  $AC$  is resolved into two components  $F_x$  and  $F_y$ , as shown in Fig. 10.11.

But  $F_x =$  Force due to water on vertical face  $AE$   
 $= w \times A \times \bar{h}$

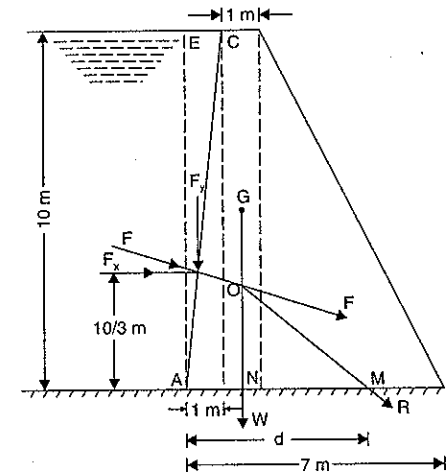

Fig. 10.11

$$= 9810 \times (10 \times 1) \times \frac{10}{2} \quad (\because \text{Area, } A = AE \times 1)$$

$$= 490500 \text{ N}$$

The force  $F_x$  will act at a height of  $\frac{10}{3}$  m above the base of the dam.

$$F_y = \text{Weight of water in wedge } AEC$$

$$= w \times \text{Area of } AEC \times 1 \quad (\because \text{Length of dam} = 1 \text{ m})$$

$$= 9810 \times \frac{10 \times 1}{2} \times 1 = 49050 \text{ N.}$$

The force  $F_y$  will act downward through the C.G. of the triangle  $AEC$  i.e. at a distance  $\frac{1}{3} \times 1 = \frac{1}{3}$  m from  $AO$ .

$$\text{Weight of dam, } W = w_0 \times \left( \frac{a+b}{2} \right) \times H = 19620 \times \left( \frac{1+7}{2} \right) \times 10 = 784800 \text{ N.}$$

The weight  $W$  will be acting through the C.G. of the dam.

The position of C.G. of the dam (i.e., distance  $AN$ ) is obtained by splitting the trapezoidal into triangles and rectangle, taking the moments of their areas about  $A$  and equating to the moment of area of the trapezoidal about the point  $A$ .

$$\therefore \left( \frac{10 \times 1}{2} \times \frac{2}{3} \right) + (10 \times 1 \times 1.5) + \frac{10 \times 5}{2} \times \left( 2 + \frac{5}{3} \right) = \frac{(a+b)}{2} \times H \times AN$$

$$\text{or } 3.33 + 15 + 91.67 = \left( \frac{1+7}{2} \right) \times 10 \times AN = 40 \times AN$$

$$\therefore AN = \frac{110}{40} = 2.75 \text{ m}$$

The resultant force  $R$  cuts the base at  $M$ . To find the distance of  $M$  from  $A$  (i.e., distance  $AM$ ), take the moments of all forces about the point  $M$ .

$$\therefore F_x \times \frac{10}{3} - F_y \times (AM - 0.33) - W \times NM = 0$$

$$\text{or } 490500 \times \frac{10}{3} - 49050 \times (AM - 0.33) - 784800 \times (AM - AN) = 0$$

$$(\because NM = AM - AN)$$

$$\text{or } \frac{4905000}{3} - 490500 AM + 16350 - 784800 AM + 784800 \times 2.75 = 0$$

$$(\because AN = 2.75)$$

$$\text{or } \frac{4905000}{3} + 16350 + 784800 \times 2.75 = 784800 AM + 490500 AM$$

$$\text{or } 3809550 = 833850 AM$$

$$\therefore AM = \frac{3809550}{833850} = 4.568$$

$$\text{or } d = 4.568 \quad (\because AM = d)$$

$$\text{Now the eccentricity, } e = d - \frac{b}{2}$$

$$= 4.568 - \frac{7}{2} = 4.568 - 3.5 = 1.068 \text{ m.}$$

#### Maximum and Minimum stresses on the base

Let  $\sigma_{max}$  = Maximum stress on the base,

$\sigma_{min}$  = Minimum stress on the base.

Using equation (10.12), we get

$$\sigma_{max} = \frac{V}{b} \left( 1 + \frac{6 \cdot e}{b} \right)$$

where  $V$  = Total vertical forces on the dam

$$= W + F_y = 784800 + 49050 = 833850 \text{ N}$$

$$\therefore \sigma_{max} = \frac{833850}{7} \left( 1 + \frac{6 \times 1.068}{7} \right)$$

$$= 228167 \text{ N/m}^2. \text{ Ans.}$$

Using equation (10.13), we get

$$\sigma_{min} = \frac{V}{b} \left( 1 - \frac{6 \cdot e}{b} \right)$$

$$= \frac{833850}{7} \left( 1 - \frac{6 \times 1.068}{7} \right)$$

$$= 10077.8 \text{ N/m}^2. \text{ Ans.}$$

**Problem 10.9.** A masonry dam of trapezoidal section is 10 m high. It has top width of 1 m and bottom width 6 m. The face exposed to water has slope of 1 horizontal to 10 vertical.

Calculate the maximum and minimum stresses on the base when the water level coincides with the top of the dam. Take weight density of masonry as 22.563 kN/m<sup>3</sup>.

**Sol.** Given :

Height of dam,  $H = 10 \text{ m}$

Height of water,  $h = 10 \text{ m}$

Top width of dam,  $a = 1 \text{ m}$

Bottom width of dam,  $b = 6 \text{ m}$

Slope of the face AC which is exposed to water = 1 hor. to 10 vertical.

$$\therefore EC = 1 \text{ m} \quad (\because AE = 10 \text{ m})$$

Weight density of masonry,

$$w_0 = 22.563 \text{ kN/m}^3$$

$$= 22563 \text{ N/m}^3$$

Consider one metre length of dam.

Now the force  $F$  due to water acting on the face AC is resolved into two components  $F_x$  and  $F_y$ , as shown in Fig. 10.12.

Force,  $F_x$  = Force due to water acting on vertical face AE

$$= w \times A \times \bar{h}$$

$$= 9810 \times (10 \times 1) \times \frac{10}{2}$$

$$\left( \because \bar{h} = \frac{10}{2} \right)$$

$$= 490500 \text{ N}$$

and Force,  $F_y$  = Weight of water in the wedge AEC

$$= w \times \text{Area of triangle AEC} \times 1$$

$$= w \times \frac{EC \times AE}{2} \times 1$$

$$= 9810 \times \frac{1 \times 10}{2} \times 1 = 49050 \text{ N}$$

Weight of dam,

$$W = w_0 \times \left( \frac{a+b}{2} \right) \times H = 22563 \times \left( \frac{1+6}{2} \right) \times 10$$

$$= 789705 \text{ N.}$$

The position of the C.G. of the dam (i.e., distance AN) is obtained by splitting the trapezoidal into triangles and rectangle, taking the moments of their areas about A, and equating to the moment of the area of the trapezoidal about point A.

$$\therefore \left( \frac{10 \times 1}{2} \right) \times \frac{2}{3} + 10 \times 1 \times \left( 1 + \frac{1}{2} \right) + \frac{10 \times 4}{2} \times \left( 1 + 1 + \frac{1}{3} \times 4 \right) = \left( \frac{a+b}{2} \right) \times H \times AN$$

$$\text{or } 3.33 + 15 + 20 \times \frac{10}{3} = \frac{(1+6)}{2} \times 10 \times AN$$

$$85 = 35 \times AN$$

$$\therefore AN = \frac{85}{35} = \frac{17}{7} = 2.43 \text{ m.}$$

Now let the resultant  $R$  of forces  $F$  and  $W$  cut the base at  $M$ .

Taking the moments of all forces (i.e., force  $F_x$ ,  $F_y$  and  $W$ ) about the point  $M$ , we get

$$F_x \times \frac{10}{3} = W \times NM + F_y \times \left( AM - \frac{1}{3} \times 1 \right)$$

$$490500 \times \frac{10}{3} = 789705 \times (AM - AN) + 49050 \left( AM - \frac{1}{3} \right)$$

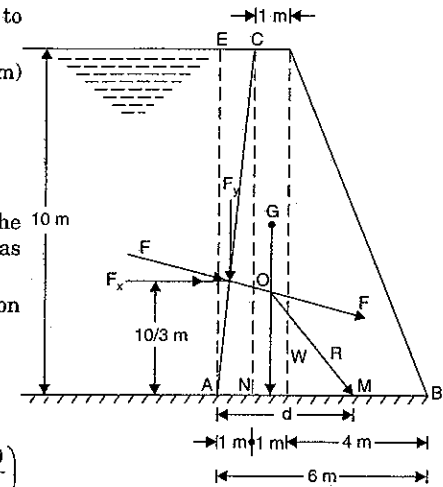

Fig. 10.12

$$\frac{4905000}{3} = 789705 \times AM - 789705 \times AN + 49050 \times AM - \frac{49050}{3}$$

$$= AM \times (789705 + 49050) - 789705 \times \frac{17}{7} - \frac{49050}{3} \quad (\because AN = \frac{17}{7})$$

$$= AM \times 838755 - 1917855 - \frac{49050}{3}$$

$$\therefore AM \times 838755 = \frac{4905000}{3} + 1917855 + \frac{49050}{3} = 3569205$$

$$\therefore AM = \frac{3569205}{838755} = 4.255 \text{ m}$$

$$\therefore \text{Eccentricity, } e = AM - \frac{b}{2} \quad (\because AM = d)$$

$$= 4.255 - \frac{6}{2} = 4.255 - 3.0 = 1.255 \text{ m.}$$

### Maximum stress on the base

Using equation (10.12), we get

$$\sigma_{max} = \frac{V}{b} \left( 1 + \frac{6 \cdot e}{b} \right)$$

where  $V$  = Total vertical forces on the dam

$$= W + F_y = 789705 + 49050 = 838755 \text{ N}$$

$$\therefore \sigma_{max} = \frac{838755}{6} \left( 1 + \frac{6 \cdot 1.255}{6} \right) = 315232 \text{ N/m}^2. \text{ Ans.}$$

Using equation (10.13), we get

$$\sigma_{min} = \frac{V}{b} \left( 1 - \frac{6 \cdot e}{b} \right)$$

$$= \frac{838755}{6} \left( 1 - \frac{6 \cdot 1.255}{6} \right) = 35647 \text{ N/m}^2. \text{ Ans.}$$

## 10.6. STABILITY OF A DAM

A dam should be stable under all conditions. But the dam may fail :

1. By sliding on the soil on which it rests,
2. By overturning,
3. Due to tensile stresses developed, and
4. Due to excessive compressive stresses.

**10.6.1. Condition to Prevent the Sliding of the Dam.** Fig. 10.13 shows a dam of trapezoidal section of height  $H$  and having water upto a depth of  $h$ . The forces acting on the dam are :

(i) Force due to water pressure  $F$  acting horizontally at a height of  $\frac{h}{3}$  above the base.

(ii) Weight of the dam  $W$  acting vertically downwards through the C.G. of the dam.

The resultant  $R$  of the forces  $F$  and  $W$  is passing through the point  $M$ . The dam will be in equilibrium if a force  $R^*$  equal to  $R$  is applied at the point  $M$  in the opposite direction of  $R$ . Here  $R^*$  is the reaction of the dam. The reaction  $R^*$  can be resolved into two components. The

vertical component of  $R^*$  will be equal to  $W$  whereas the horizontal component will be equal to frictional force at the base of the dam.

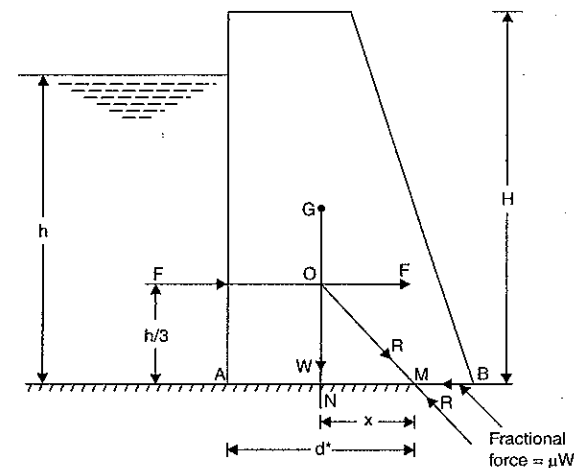

Fig. 10.13

Let  $\mu$  = Co-efficient of friction between the base of the dam and the soil.

Then maximum force of friction is given by,

$$F_{max} = \mu \times W \quad \dots(10.14)$$

If the force of friction *i.e.*,  $F_{max}$  is more than the force due to water pressure (*i.e.*,  $F$ ), the dam will be safe against sliding.

**10.6.2. Condition to Prevent the Overturning of the Dam.** If the resultant  $R$  of the weight  $W$  of the dam and the horizontal  $F$  due to water pressure, strikes the base within its width *i.e.*, the point  $M$  lies within the base  $AB$  of Fig. 10.13, there will be no overturning of the dam. This is proved as :

For the dam shown in Fig. 10.13, taking moments about  $M$ .

Moment due to horizontal force  $F$  about point  $M$

$$= F \times \frac{h}{3} \quad \dots(i)$$

Moment due to weight  $W$  about point  $M$

$$= W \times x \quad \dots(ii)$$

The moment, due to horizontal force  $F$ , tends to overturn the dam about the point  $B$ ; whereas the moment due to weight  $W$  tends to restore the dam. If the moment due to weight  $W$  is more than the moment due to force  $F$ , there will be no overturning of the dam. For the equilibrium of the dam, the two moments should be equal.

$$\therefore F \times \frac{h}{3} = W \times x \quad \dots(iii)$$

Since overturning can take place about point  $B$ , hence restoring moment about the point  $B$

$$= W \times NB$$

But overturning moment due to force  $F$  about point  $B$

$$= F \times \frac{h}{3} = W \times x \quad \left( \because \text{from equation (iii)} F \times \frac{h}{3} = W \times x \right)$$

There will be no overturning about point  $B$ , if restoring moment about  $B$  is more than the overturning moment about  $B$  i.e.,

$$\text{if} \quad W \times NB > W \times x$$

$$\text{or} \quad NB > x$$

$$> NM \quad (\because x = NM)$$

This means that there will be no overturning of the dam if point  $M$  lies between  $N$  and  $B$  or between  $A$  and  $B$ .

**10.6.3. Condition to Avoid Tension in the Masonry of the Dam at its Base.** The masonry of the dam is weak in tension and hence the tension in the masonry of the dam should be avoided. The maximum and minimum stresses across the base of the dam are given by equations (10.10) and (10.11). The maximum stress is always compressive but the minimum

stress given by equation (10.11) will be tensile if the term  $\left(1 - \frac{6 \cdot e}{b}\right)$  is negative. In the limiting case, there will be no tensile stress at the base of dam

$$\text{if} \quad 1 - \frac{6 \cdot e}{b} \geq 0$$

$$\text{or} \quad b - 6 \cdot e \geq 0 \quad \text{or} \quad b \geq 6 \cdot e$$

$$\text{or} \quad 6 \cdot e \leq b \quad \text{or} \quad e \leq \frac{b}{6} \quad \dots(10.15)$$

where  $e$  = Eccentricity and  $b$  = Base width of dam.

This means that the eccentricity of the resultant can be equal to  $\frac{b}{6}$  on the either side of the middle point of the base section. Hence the resultant must lie within the *middle third* of the base width, in order to avoid tension. Refer to Fig. 10.13.

If  $d^*$  = Maximum distance between  $A$  and the point through which resultant force  $R$  meets the base.

$$\text{Then} \quad e = d^* - \frac{b}{2} \quad \dots(i)$$

But to avoid tension at the base of the dam, maximum value of eccentricity,

$$e \leq \frac{b}{6} \quad \dots(ii)$$

From equations (i) and (ii), we have

$$d^* - \frac{b}{2} \leq \frac{b}{6}$$

$$\therefore d^* \leq \frac{b}{6} + \frac{b}{2} \leq \frac{b + 3b}{6} \leq \frac{4b}{6} \leq \frac{2}{3}b \quad \dots(10.16)$$

Hence if the maximum distance between  $A$  and the point through which resultant force  $R$  meets the base (i.e., distance  $d^*$ ) is equal to or less than two third of the base width, there will be no tension at the base of dam.

**10.6.4. Condition to Avoid the Excessive Compressive Stresses at the Base of the Dam.** The maximum and minimum stresses across the base of the dam are given by

equations (10.10) and (10.11). The condition to avoid the excessive compressive stresses in the masonry of the dam is that the  $p_{max}$  i.e., maximum stress in the masonry should be less than the permissible stress in the masonry.

**Problem 10.10.** A trapezoidal masonry dam having 4 m top width, 8 m bottom width and 12 m high, is retaining water upto a height of 10 m as shown in Fig. 10.14. The density of masonry is 2000 kg/m<sup>3</sup> and coefficient of friction between the dam and soil is 0.55. The allowable compressive stress is 343350 N/m<sup>2</sup>. Check the stability of dam.

**Sol.** Given :

$$\text{Top width of dam,} \quad a = 4 \text{ m}$$

$$\text{Bottom width of dam,} \quad b = 8 \text{ m}$$

$$\text{Height of dam,} \quad H = 12 \text{ m}$$

$$\text{Depth of water,} \quad h = 10 \text{ m}$$

$$\text{Density of masonry,} \quad \rho_0 = 2000 \text{ kg/m}^3$$

$$\therefore \text{Weight density of masonry,}$$

$$w_0 = 2000 \times 9.81 \text{ N/m}^3$$

$$\text{Co-efficient of friction,}$$

$$\mu = 0.55$$

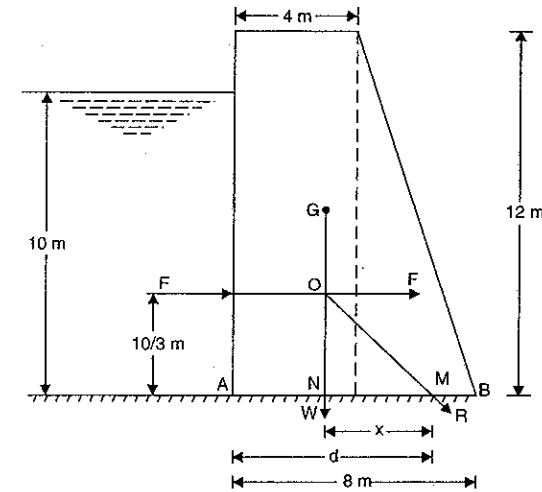

Fig. 10.14

Allowable compressive stress

$$= 343350 \text{ N/m}^2$$

Consider on metre length of dam.

The horizontal force  $F$  exerted by water on the vertical side of dam is given by

$$F = w \times A \times \bar{h}$$

$$= 1000 \times 9.81 \times (10 \times 1) \times \frac{10}{2}$$

$$= 490500 \text{ N}$$



The force  $F$  will be acting at a height of  $\frac{10}{3}$  m above the base.

Weight of the dam per metre length is given by,

$$w = \text{Weight density of masonry} \times \text{Area of trapezoidal section} \times 1$$

$$= w_0 \times \left( \frac{a+b}{2} \right) \times H \times 1 = 2000 \times 9.81 \times \left( \frac{4+8}{2} \right) \times 12 \times 1$$

$$= 1412640 \text{ N.}$$

The weight  $W$  will be acting at the C.G. of the dam. The C.G. of the dam is obtained by splitting the trapezoidal section into rectangle and triangle, taking the moments of their areas about the point  $A$  and equating to the moment of the area of the trapezoidal about  $A$ .

$$\therefore 4 \times 12 \times 2 + \frac{4 \times 12}{2} \times \left( 4 + \frac{4}{3} \right) = \left( \frac{4+8}{2} \right) \times 12 \times AN$$

$$\text{or } 96 + 24 \times \frac{16}{3} = 72 \times AN$$

$$\text{or } 96 + 128 = 72 \times AN$$

$$\therefore AN = \frac{96 + 128}{72} = \frac{224}{72} = 3.11 \text{ m.}$$

Taking the moments of the forces acting on the dam about the point  $M$ .

$$F \times \frac{10}{3} = W \times x$$

$$\text{or } x = \frac{F}{W} \times \frac{10}{3} = \frac{490500}{1412640} \times \frac{10}{3} = 1.157 \text{ m}$$

$$\therefore \text{Distance } AM = AN + x = 3.11 + 1.157 = 4.267 \text{ m.}$$

(i) Check for the tension in the masonry of the dam

Now from equation (10.15), we have

$$d^* \leq \frac{2}{3} \times b \leq \frac{2}{3} \times 8.0$$

$$\leq 5.33 \text{ m.}$$

As the distance  $AM$  is less than  $d^*$  or  $\frac{2}{3} \times b$  (i.e., 5.33 m), the dam is safe against the tension in its masonry at the base. **Ans.**

(ii) Check for overturning

The resultant is passing through the base  $AB$  of the dam and hence there will be no overturning.

(iii) Check for sliding of the dam

From equation (10.14), the maximum force of friction is obtained as,

$$F_{max} = \mu \times W$$

$$= 0.55 \times 1412640 = 776952 \text{ N.}$$

Since force of friction is more than the horizontal force due to water (i.e.,  $F = 490500$ ), the dam is safe against sliding.

(iv) Check for excessive compressive stress at the base of the dam

From equation (10.10), the maximum stress at the base of the dam is given by

$$\sigma_{max} = \frac{W}{b} \left( 1 + \frac{6e}{b} \right)$$

$$\text{where } e = d - \frac{b}{2} = AM - \frac{b}{2} \quad (\because d = AM)$$

$$= 4.267 - \frac{8}{2} = 0.267 \text{ m}$$

$$W = 1412640 \text{ N}$$

$$\therefore \sigma_{max} = \frac{1412640}{8} \left( 1 + \frac{6 \times 0.267}{8} \right) = 211940 \text{ N/m}^2.$$

Since the maximum stress is less than the allowable stress, hence the masonry of the dam is safe against excessive compressive stress. **Ans.**

**Problem 10.11.** A trapezoidal masonry dam having top width 1 m and height 8 m, retaining water upto a height of 7.5 m. The water face of the dam is vertical. The density of masonry is  $2240 \text{ kg/m}^3$  and co-efficient of friction between the dam and soil is 0.6. Find the minimum bottom width of the dam required.

**Sol. Given :**

Top width,  $a = 1.0 \text{ m}$

Height of dam,  $H = 8.0 \text{ m}$

Depth of water,  $h = 7.5 \text{ m}$

Density of masonry,  $\rho_0 = 2240 \text{ kg/m}^3$

$\therefore$  Weight density of masonry,

$$w_0 = \rho_0 \times g = 2240 \times 9.81 \text{ N/m}^3$$

Co-efficient of friction,  $\mu = 0.60$

Let  $b =$  Width of dam at the base. Consider one metre run of the dam. Horizontal force  $F$  exerted by water is given by,

$$F = w \times A \times \bar{h}$$

$$= 1000 \times 9.81 \times (7.5 \times 1) \times \frac{7.5}{2}$$

$$(\because w \text{ for water} = \rho \times g)$$

$$= 9810 \text{ N/m}^3$$

$$= 275906.25 \text{ N.}$$

The weight of dam per metre run is given by,

$$W = w_0 \left( \frac{a+b}{2} \right) \times H \times 1$$

$$= 2240 \times 9.81 \left( \frac{1+b}{2} \right) \times 8 \times 1 = 87897.6 (b+1) \text{ N.}$$

The weight  $W$  will be acting through the C.G. of the dam. The distance of the C.G. of the dam from  $A$  is given by equation (10.8).

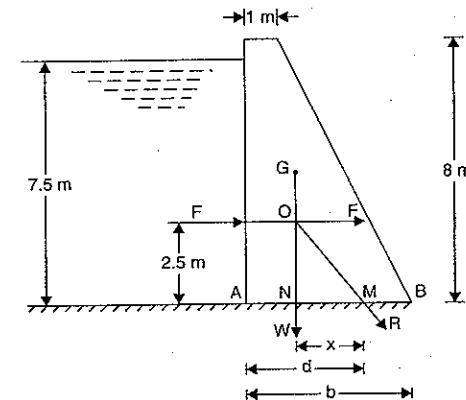

Fig. 10.15

$$\begin{aligned} AN &= \frac{a^2 + ab + b^2}{3(a+b)} \\ &= \frac{1^2 + 1 \times b + b^2}{3(1+b)} = \frac{1+b+b^2}{3(1+b)} \end{aligned}$$

The horizontal distance  $x$ , between the line of action of  $W$  and the point at which the resultant force  $R$  cuts the base, is obtained by using equation (10.3).

$$\begin{aligned} x &= \frac{F}{W} \times \frac{h}{3} \\ &= \frac{275906.25}{87897.6(b+1)} \times \frac{7.5}{3} = \frac{7.847}{(b+1)} \end{aligned}$$

$$\begin{aligned} \therefore \text{Distance } d = AM &= AN + NM = AN + x \\ &= \frac{1+b+b^2}{3(1+b)} + \frac{7.847}{(b+1)} \end{aligned} \quad \dots(i)$$

(i) There will be no tension in the dam at the base if  $d \leq \frac{2}{3}b$

Hence for the limiting case  $d = \frac{2}{3}b$

$$\text{or } \frac{1+b+b^2}{3(1+b)} + \frac{7.847}{b+1} = \frac{2}{3}b \quad [\text{Substituting the value of } d \text{ from equation (i)}]$$

$$1 + b + b^2 + 3 \times 7.847 = 2b(b+1)$$

$$\text{or } 1 + b + b^2 + 22.461 = 2b^2 + 2b$$

$$\text{or } b^2 + b - 23.461 = 0.$$

The above equation is a quadratic equation. Its solution is

$$\begin{aligned} b &= \frac{-1 \pm \sqrt{1^2 + 4 \times 1 \times 23.461}}{2} = \frac{-1 \pm 9.7387}{2} \\ &= \frac{-1 + 9.7387}{2} \quad (\text{Neglecting negative value}) \\ &= 4.37 \text{ m} \end{aligned} \quad \dots(ii)$$

(ii) There will be no sliding of the dam if

$$\mu W > F$$

$$\text{or } 0.6 \times 87897.6(b+1) > 275906.25$$

$$\text{or } (b+1) > \frac{275906.25}{0.6 \times 87897.6} > 5.23$$

$$\text{or } b > 4.23 \quad \dots(iii)$$

Hence the minimum bottom width of the dam, so that there is no tension at the base of the dam and also there is no sliding of the dam, should be greater of the two values given by equations (ii) and (iii).

$\therefore$  Minimum bottom width = 4.37 m. **Ans.**

**Problem 10.12.** A masonry gravity dam is vertical at the water face and has a height of 8.5 m above its base. It is 1.2 m wide at the top. It retains water upto a height of 8 m above the base. The density of masonry is 2300 kg/m<sup>3</sup>. Determine the minimum bottom width required to

satisfy "no tension" condition in the section and also to ensure that there is no sliding at the base. The co-efficient of friction between the dam and foundation is 0.5.

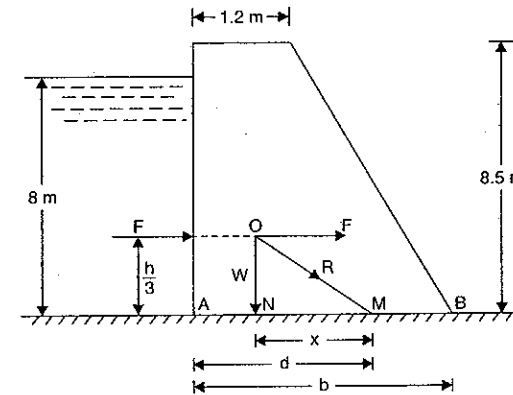

Fig. 10.15 (a)

**Sol. Given :**

Height of dam,  $H = 8.5$  m

Width at top,  $a = 1.2$  m

Depth of water,  $h = 8$  m

Density of masonry,  $\rho_0 = 2300$  kg/m<sup>3</sup>

$\therefore$  Weight density of masonry,

$$w_0 = \rho_0 \times g = 2300 \times 9.81 \text{ N/m}^3$$

Weight density of water,

$$w = 1000 \times 9.81 \text{ N/m}^3 = 9810 \text{ N/m}^3$$

Coefficient of friction,  $\mu = 0.5$

Let  $b$  = Bottom width at the base

Consider 1 m length of the dam

The force  $F$  exerted by water is given by

$$\begin{aligned} F &= w \times A \times \bar{h} = 9810 \times (h \times 1) \times \frac{h}{2} \\ &= 9810 \times (8 \times 1) \times \frac{8}{2} \\ &= 313920 \text{ N} \end{aligned} \quad \dots(i)$$

The weight of dam is given by

$$\begin{aligned} W &= w_0 \times \left( \frac{a+b}{2} \right) \times H \times 1 \\ &= (2300 \times 9.81) \times \left( \frac{1.2+b}{2} \right) \times 8.5 \times 1 \\ &= 95892.75 (1.2+b) \end{aligned} \quad \dots(ii)$$

The horizontal distance  $x$ , between the line of action of  $W$  and the point  $M$  at which the resultant force  $R$  cuts the base, is given by equation (10.3) as

$$x = \frac{F}{W} \times \frac{h}{3} = \frac{313920}{95892.75(1.2+b)} \times \frac{8}{3} = \frac{26.19}{3(1.2+b)}$$

The weight  $W$  will be acting through the C.G. of the dam. The horizontal distance of the C.G. of the dam section from point  $A$  is given by equation (10.8) as

$$AN = \frac{a^2 + ab + b^2}{3(a+b)} = \frac{1.2^2 + 1.2b + b^2}{3(1.2+b)} = \frac{1.44 + 1.2b + b^2}{3(1.2+b)}$$

Now distance,

$$\begin{aligned} d = AM &= AN + NM = AN + x \\ &= \frac{1.44 + 1.2b + b^2}{3(1.2+b)} + \frac{26.19}{3(1.2+b)} \\ &= \frac{1.44 + 1.2b + b^2 + 26.19}{3(1.2+b)} \\ &= \frac{27.63 + 1.2b + b^2}{3(1.2+b)} \end{aligned} \quad \dots(iii)$$

(a) Width at the base for no tension at the base

There will be no tension in the dam at the base if

$$d \leq \frac{2}{3}b$$

$$\text{or } \frac{27.63 + 1.2b + b^2}{3(1.2+b)} \leq \frac{2}{3}b$$

$$\text{or } 27.63 + 1.2b + b^2 \leq 2b(1.2+b)$$

$$\leq 2.4b + 2b^2$$

$$\text{or } 0 \leq 2.4b + 2b^2 - 27.63 - 1.2b - b^2$$

$$\text{or } 0 \leq b^2 + 1.2b - 27.63$$

$$\text{or } b^2 + 1.2b - 27.63 \geq 0$$

For limiting case,  $b^2 + 1.2b - 27.63 = 0$ .

The above equation is a quadratic equation. Hence its roots are given by

$$b = \frac{-1.2 \pm \sqrt{1.2^2 + 4 \times 1 \times 27.63}}{2 \times 1} = \frac{-1.2 \pm 10.58}{2}$$

$$= 4.69 \text{ m} \quad (\text{Neglecting } -\text{ve root which is not possible})$$

Hence there will be no tension at the base, if width  $b$  is more than 4.69 m.

(b) Width of dam for no sliding of dam at the base

There will be no sliding of the dam at the base if  $\mu W \geq F$ .

Substituting the values of  $W$  from equation (ii) and of  $F$  from equation (i), we get

$$\mu \times 95892.75(1.2+b) \geq 313920$$

$$\text{or } 0.5 \times 95892.75(1.2+b) \geq 313920$$

$$\text{or } (1.2+b) \geq \frac{313920}{0.5 \times 95892.75} \geq 6.54$$

$$\text{or } b \geq (6.54 - 1.2) \geq 5.34 \text{ m.}$$

(c) Width of dam for no tension condition and also for no sliding at the base

For no tension, we have  $b \geq 4.69 \text{ m}$

For no sliding at the base  $b \geq 5.34 \text{ m}$

To satisfy both the conditions,  $b \geq 5.34 \text{ m}$

$\therefore$  Minimum bottom width = 5.34 m. Ans.

**Problem 10.13.** A masonry dam of trapezoidal section is 12 m high with a top width of 2 m. The water face has a batter of 1 in 12. Find the minimum bottom width necessary so that tensile stresses are not induced on the base section. Assume density of masonry = 2300 kg/m<sup>3</sup>, that of water = 1000 kg/m<sup>3</sup> and no free board.

(AMIE, Summer 1984)

Sol. Given :

Height of dam,  $H = 12 \text{ m}$

Top width,  $a = 2 \text{ m}$

Slope of water face = 1 in 12

$$\text{or } \tan \theta = \frac{1}{12} = \frac{CD}{AD} = \frac{CD}{12}$$

$\therefore$  Length  $CD = 1 \text{ m}$

Density of masonry,  $\rho_0 = 2300 \text{ kg/m}^3$

$\therefore$  Weight of density of masonry,

$$w_0 = 2300 \times 9.81 \text{ N/m}^3$$

Density of water,  $\rho = 1000 \text{ kg/m}^3$

$\therefore$  Weight density of water,

$$w = 1000 \times 9.81 \text{ N/m}^3.$$

No free board means the depth of water is equal to the height of dam.

$\therefore$  Depth of water,  $h = 12 \text{ m}$

Consider one metre length of the dam.

The forces acting on the dam are :

The force  $F$  due to water acting on the face  $AC$  is perpendicular to the face  $AC$ . This force  $F$  is resolved into two components  $F_x$  and  $F_y$  as shown in Fig. 10.16.

(i) Force  $F_x$  = Force due to water acting on vertical face  $AD$

$$= w \times A \times \bar{h}$$

$$= 1000 \times 9.81 \times (12 \times 1) \times \frac{12}{2}$$

$$= 72000 \times 9.81 \text{ N.}$$

The force  $F_x$  acts at a height of  $\frac{12}{3} = 4 \text{ m}$  above the base of the dam i.e., from point  $A$ .

(ii) The force  $F_y$  = Weight of water in the wedge  $ADC$

$$= w \times \text{Area of triangle } ADC \times 1$$

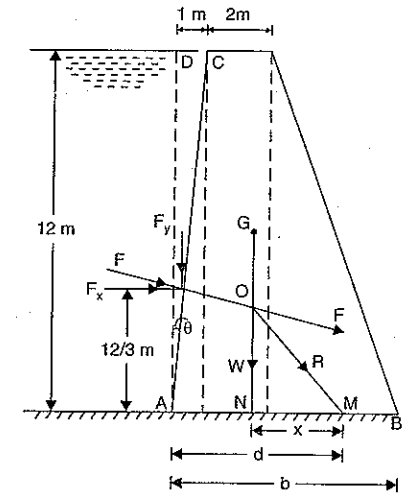

Fig. 10.16

$$= 1000 \times 9.81 \times \frac{12 \times 1}{2} \times 1 = 6000 \times 9.81 \text{ N.}$$

The line of action of  $F_y$  is at a distance of  $\frac{1}{3}$  m from line AD.

$$\begin{aligned} \text{(iii) Weight of dam, } W &= w_0 \times \text{Area of trapezoidal} \times 1 \\ &= 2300 \times 9.81 \times \left(\frac{a+b}{2}\right) \times H \times 1 \\ &= 2300 \times 9.81 \times \left(\frac{2+b}{2}\right) \times 12 \times 1 \\ &= 13800 \times 9.81(2+b) \text{ N.} \end{aligned}$$

The weight of the dam ( $W$ ) is acting at the C.G. of the dam. The position of C.G. of the dam (i.e., distance  $AN$  in Fig. 10.16) is obtained by splitting the trapezoidal into triangles and rectangle, taking the moments of their areas about  $A$  and equating to the moment of area of the trapezoidal about the point  $A$ .

$$\therefore \left(\frac{12 \times 1}{2}\right) \times \frac{2}{3} + 12 \times 2 \times (1+1) + \frac{12 \times (b-3)}{2} \times \left[3 + \frac{1}{3} \times (b-3)\right] = \left(\frac{a+b}{2}\right) \times H \times AN$$

$$\text{or } 4 + 48 + 6(b-3) \times \left(3 + \frac{b-3}{3}\right) = \left(\frac{2+b}{2}\right) \times 12 \times AN$$

$$\text{or } 52 + 6(b-3) \left(\frac{b+6}{3}\right) = 6(2+b) \times AN$$

$$\text{or } AN = \frac{156 + 6(b-3)(b+6)}{3 \times 6 \times (2+b)}$$

The resultant  $R$  cuts the base at  $M$ . To find the distance of  $M$  from  $A$  (i.e., distance  $AM$  or  $d$ ), take the moments of all forces about the point  $M$ .

$$\therefore F_x \times 4 - F_y \times \left(d - \frac{1}{3}\right) - W \times x = 0$$

$$\text{or } 72000 \times 9.81 \times 4 - 6000 \times 9.81 \times \left(d - \frac{1}{3}\right) - 13800 \times 9.81(2+b) \times x = 0$$

$$\begin{aligned} \text{But } x &= d - AN \\ &= d - \frac{156 + 6(b-3)(b+6)}{18(2+b)} \end{aligned} \quad \dots(i)$$

Substituting the value of  $x$  in equation (i), we get

$$\begin{aligned} 9.81 \times 72000 \times 4 - 6000 \times 9.81 \times \left(d - \frac{1}{3}\right) - 13800 \times 9.81(2+b) \\ \times \left[d - \frac{156 + 6(b-3)(b+6)}{18(2+b)}\right] = 0. \end{aligned}$$

To avoid the tension at the base of the dam, the distance  $d \leq \frac{2}{3} b$ .

$\therefore$  Taking the limiting value, we get

$$d = \frac{2}{3} b.$$

Substituting this value of  $d$  in above equation, we get

$$9.81 \times 288000 - 6000 \times 9.81 \left(\frac{2b}{3} - \frac{1}{3}\right) - 13800 \times 9.81(2+b)$$

$$\times \left[\frac{2b}{3} - \frac{156 + 6(b-3)(b+6)}{18(2+b)}\right] = 0.$$

$$\text{or } 288000 - 2000(2b-1) - 13800(2+b) \times \left[\frac{2b \times 6 \times (2+b) - 156 - 6(b-3)(b+6)}{18(2+b)}\right] = 0$$

$$\text{or } 288000 - 2000(2b+1) - \frac{13800}{18} [12b(2+b) - 156 - 6(b-3)(b+6)] = 0$$

$$\text{or } 2880 = 20(2b-1) - \frac{138}{18} [24b + 12b^2 - 156 - 6(b^2 + 3b - 18)] = 0$$

$$\text{or } 2880 - 40b + 20 - \frac{23}{3} [6b^2 + 6b - 48] = 0$$

$$\text{or } 2880 - 40b + 20 - 23 [2b^2 + 2b - 16] = 0$$

$$\text{or } 2880 - 40b + 20 - 46b^2 - 46b + 368 = 0$$

$$\text{or } -46b^2 - 86b + 3268 = 0$$

$$46b^2 + 86b - 3268 = 0.$$

The above equation is a quadratic equation. Hence its solution is

$$b = \frac{-86 \pm \sqrt{86^2 + 4 \times 46 \times 3268}}{2 \times 46} = \frac{-86 \pm 780.19}{92}$$

$$= \frac{-86 + 780.12}{92} \quad (\text{Neglecting -ve roots})$$

$$= 7.545 \text{ m. Ans.}$$

**Problem 10.14.** A mass concrete dam shown in Fig. 10.17 (a) has a trapezoidal cross-section. The height above the foundation is 61.5 m and its water face is vertical. The width at the top is 4.5 m.

Calculate the necessary minimum width of the dam at its bottom, to ensure that no tension shall be developed when water is stored upto 60 metres. Draw the pressure diagram at the base of the dam, for this condition, and indicate the maximum pressure developed.

Take density of concrete as  $2,400 \text{ kg/m}^3$  and that of water as  $1,000 \text{ kg/m}^3$ .

**Sol. Given :**

Height of dam,  $H = 61.5 \text{ m}$

Top width of dam,  $a = 4.5 \text{ m}$

Height of water,  $h = 60 \text{ m}$

Density of concrete,  $\rho_0 = 3400 \text{ kg/m}^3$

Weight density of concrete,

$$w_0 = 2400 \times 9.81 \text{ N/m}^3$$

Density of water,  $\rho = 1000 \text{ kg/m}^3$

$\therefore$  Weight density of water,

$$w = 1000 \times 9.81 \text{ N/m}^3$$

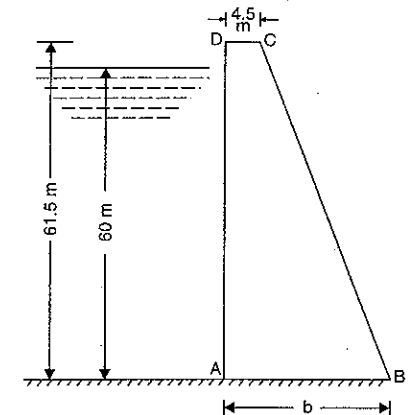

Fig. 10.17 (a)

Let  $b$  = Minimum width of the dam at its bottom in metres,  
 $F$  = Total water pressure on the dam per metre length,  
 $x$  = Horizontal distance between the C.G. of the dam section and point  $M$ .

$$\text{Using the relation, } F = \frac{wh^2}{2} \\ = \frac{1000 \times 9.81(60^2)}{2} = 17658000 \text{ N} \quad \dots(i)$$

We know that the weight of dam per metre length,

$$W = w_0 \times \frac{(a \times b)}{2} \times H \times 1 \\ = 2400 \times 9.81 \times \frac{4.5 + b}{2} \times 61.5 \text{ N} \\ = 723978(4.5 + b) \text{ N} \quad \dots(ii)$$

Now let us find out the position of the C.G. of the dam section. We know that the distance  $AN$  from equation (10.8) is given by

$$AN = \frac{a^2 + ab + b^2}{3(a + b)} = \frac{(4.5)^2 + 4.5b + b^2}{3(4.5 + b)} \\ = \frac{20.25 + 4.5b + b^2}{3(4.5 + b)}$$

Now from equation (10.3)

$$x = \frac{F}{W} \times \frac{h}{3} \\ = \frac{17658000}{723978(4.5 + b)} \times \frac{60}{3} = \frac{488}{(4.5 + b)}$$

$\therefore$  Horizontal distance  $AM$

$$d = AN + x = \frac{20.25 + 4.5b + b^2}{3(4.5 + b)} + \frac{488}{4.5 + b} \\ = \frac{20.25 + 4.5b + b^2 + 1464}{3(4.5 + b)} \\ = \frac{1484.25 + 4.5b + b^2}{3(4.5 + b)}$$

There will be no tension in the dam at the base if

$$d \leq \frac{2}{3} b$$

Hence for the limiting case  $d = \frac{2b}{3}$

$$\text{or } \frac{1484.25 + 4.5b + b^2}{3(4.5 + b)} = \frac{2b}{3}$$

$$\text{or } 1484.25 + 4.5b + b^2 = 2b(4.5 + b) = 9b + 2b^2$$

$$\text{or } b^3 + 4.5b - 1484.25 = 0.$$

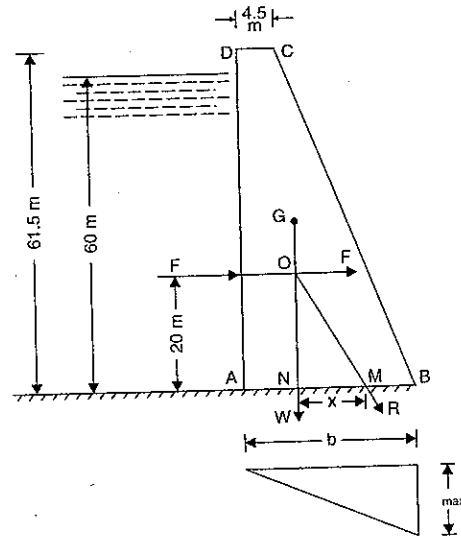

Fig. 10.17 (b)

Solving this equation, as a quadratic equation for  $b$ ,

$$\therefore b = \frac{-4.5 \pm \sqrt{(4.5)^2 + 4 \times 1484.25}}{2} \\ = \frac{-4.5 + 77.05}{2} = 36.725 \text{ m. Ans.}$$

**Pressure diagram at the base of the dam**

Let  $\sigma_{max}$  = Maximum stress across the base at  $B$ .

Substituting the value of  $b$  in equation (ii)

$$W = 723978(4.5 + b) = 723978(4.5 + 36.275) \\ = 29520252 \text{ N}$$

Using equation (10.10),

$$\sigma_{max} = \frac{W}{b} \left(1 + \frac{6e}{b}\right)$$

But from equation (10.15),

$$e = \frac{b}{6}$$

$$\therefore \sigma_{max} = \frac{2W}{b} = \frac{2 \times 29520252 \text{ N}}{26.275} = 1627479 \text{ N/m}^2 \\ = 1.6275 \text{ MN/m}^2 \text{ and } \sigma_{min} = 0.$$

The pressure diagram at the base of the dam is shown in Fig. 10.17(b). **Ans.**

## 10.7. RETAINING WALLS

The walls which are used for retaining the soil or earth, are known as retaining walls. The earth, retained by a retaining wall, exerts pressure on the retaining wall in the same way as water exerts pressure on the dam. A number of theories have been evolved to determine the pressure exerted by the soil or earth on the retaining wall. One of the theories is Rankine's theory of earth pressure. Before discussing Rankine's theory, let us define the angle or repose and study the equilibrium of a body on an inclined plane.

**10.7.1. Angle of Repose.** It is defined as the maximum inclination of a plane at which a body remains in equilibrium over the inclined plane by the assistance of friction only. The earth particles lack in cohesion and have a definite angle of repose. And angle of repose\* is equal to angle of friction ( $\phi$ ). Angle of friction is the angle made by the resultant of the normal reaction and limiting force of friction with the normal reaction.

**10.7.2. Equilibrium of a Body on an Inclined Plane.** If the inclination of the inclined plane is less than the angle of repose, the body will be in equilibrium entirely by friction only. But if the inclination of the plane is greater than the angle of repose, the body will be in equilibrium only with the assistance of an external force. Let an external horizontal force  $P$  is applied on a body, which is placed on an inclined plane having inclination greater than angle of repose, to keep the body in equilibrium. There are two cases :

- (i) The body may be on the point of moving down the plane, and
- (ii) The body may be on the point of moving the plane.

**1st Case.** The body is on the point of moving down the plane.

Let  $W$  = Weight of the body

$P$  = Horizontal force applied on the body in order to prevent the body from moving down the plane

$\theta$  = Angle of inclination of the plane

$\phi$  = Angle of limiting friction *i.e.*, angle made by the resultant of normal reaction and limiting force of friction with the normal reaction as shown in Fig. 10.18 (b).

$R'$  = Resultant of normal reaction and limiting force of friction.

The forces acting on the body are shown in Fig. 10.18 (a). The body is in equilibrium under the action of three forces  $W$ ,  $P$  and  $R'$ . Applying Lami's theorem\* to the forces acting on the body, we get

$$\frac{P}{\text{sine of angle between } W \text{ and } R'} = \frac{W}{\text{sine of angle between } R' \text{ and } P}$$

or 
$$\frac{P}{\sin(90 - \theta + 90 + \phi)} = \frac{W}{\sin(\theta + 90 - \phi)}$$

or 
$$\frac{P}{\sin[180 - (\theta - \phi)]} = \frac{W}{\sin(90 + \theta - \phi)}$$

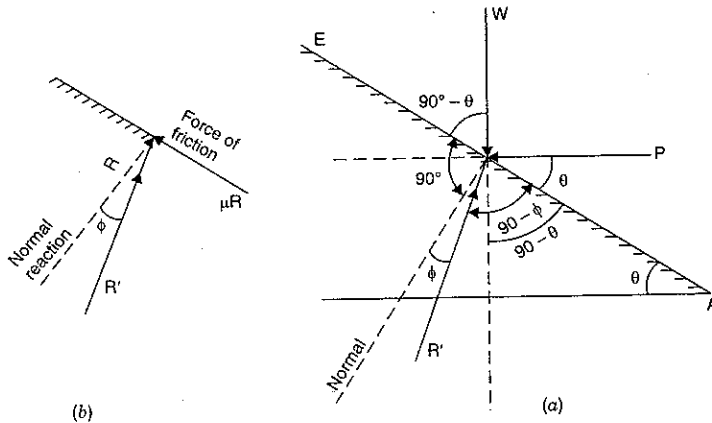

Fig. 10.18. Body moving down.

$$P = \frac{W \sin[180 - (\theta - \phi)]}{\sin[90 + (\theta - \phi)]} = \frac{W \sin(\theta - \phi)}{\cos(\theta - \phi)} = W \tan(\theta - \phi) \quad \dots(10.17)$$

**2nd Case.** The body is on the point of moving up the plane.

Let  $W$  = Weight of the body,

$P$  = Horizontal force applied on the body in order to prevent the body from moving up the plane,

$\theta$  = Angle of inclination,

$\phi$  = Angle of limiting friction *i.e.*, angle made by the resultant ( $R'$ ) of normal reaction and limiting force of friction with the normal reaction as shown in Fig. 10.19 (b),

$R'$  = Resultant of normal reaction and limiting force of friction.

\*Please refer to some standard book of Engineering Mechanics.

The forces acting on the body are shown in Fig. 10.19 (a). The body is in equilibrium under the action of three forces  $W$ ,  $P$  and  $R'$ .

Applying Lami's theorem to the forces acting on the body, we get

$$\frac{P}{\text{sine of angle between } W \text{ and } R'} = \frac{W}{\text{sine of angle between } R' \text{ and } P}$$

or 
$$\frac{P}{\sin(90 - \phi + 90 - \theta)} = \frac{W}{\sin(\theta + 90 + \phi)}$$

or 
$$\frac{P}{\sin[180 - (\theta + \phi)]} = \frac{W}{\sin[90 + (\theta + \phi)]}$$

or 
$$P = \frac{W \sin[180 - (\theta + \phi)]}{\sin[90 + (\theta + \phi)]}$$

$$= \frac{W \sin(\theta + \phi)}{\cos(\theta + \phi)}$$

$$= W \tan(\theta + \phi).$$

...(10.18)

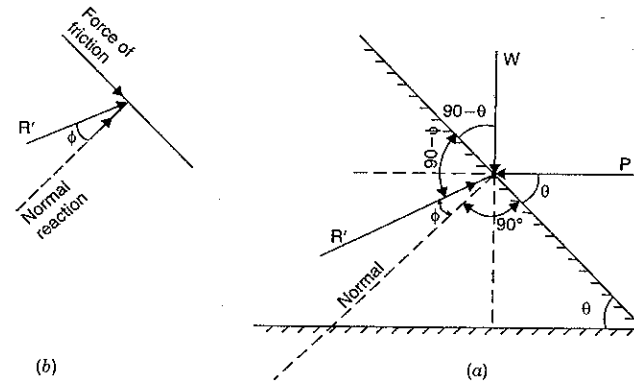

Fig. 10.19. Body moving up.

### 10.8. RANKINE'S THEORY OF EARTH PRESSURE

Rankine's theory of earth pressure is used to determine the pressure exerted by the earth or soil on the retaining wall. This theory is based on the following assumptions :

1. The earth or soil retained by a retaining wall is cohesionless.
2. Frictional resistance between the retaining wall and the retained material (*i.e.*, earth or soil) is neglected.
3. The failure of the retained material takes place along a plane, known as rupture plane.

Fig. 10.20 shows a trapezoidal retaining wall  $ABCD$  retaining the earth upto a height  $h$  on the vertical face  $AD$ . Let the earth surface is horizontal and it is in level with the top of the retaining wall. Let  $AE$  is the rupture plane which means if the wall  $AD$  is removed the wedge  $AED$  of earth will move down along the plane  $AE$ . Let  $P$  is the horizontal force offered by the

retaining wall, to keep the wedge *AED* in equilibrium. Let *w* is the weight density of the earth or soil.

Consider one metre length of the retaining wall.

The forces acting on the wedge *AED* of the retained material are :

(i) Weight of wedge *AED*,

$$\begin{aligned}
 W &= \text{Weight density of earth} \times \text{Area of } AED \times 1 \\
 &= w \times \frac{AB \times ED}{2} \times 1 \\
 &= w \times \frac{h \times h \cot \theta}{2} \left( \because \tan \theta = \frac{AD}{ED} \text{ or } ED = \frac{AD}{\tan \theta} = h \times \cot \theta \right) \\
 &= \frac{w \times h^2 \times \cot \theta}{2}
 \end{aligned}$$

(ii) The horizontal force *P* exerted by the retaining wall on the wedge.

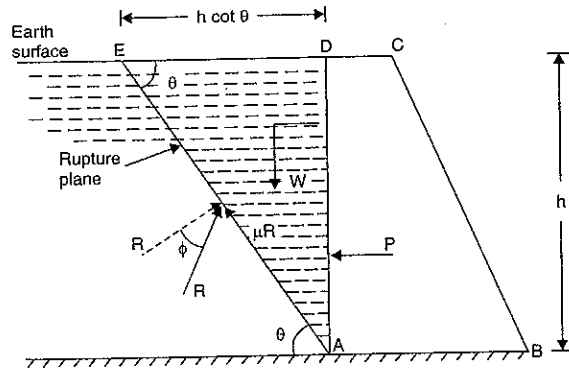

Fig. 10.20

(iii) The resultant reaction *R'* at the plane *AE*. The reaction *R'* is the resultant of normal reaction *R* and force of friction  $\mu R$ . The resultant reaction *R'* makes an angle  $\phi$  with the normal of the plane *AE*.

(iv) The frictional resistance along the contact face *AD* is neglected.

These forces are similar as shown in Fig. 10.18 (a). The wedge *AED* is in equilibrium under the action of three forces *P*, *W* and *R'*. The value of horizontal force *P* is given by equation (10.17) as

$$P = W \tan (\theta - \phi) \quad \dots(i)$$

But here

$$\begin{aligned}
 W &= \text{Weight of wedge } AED \\
 &= \frac{wh^2}{2} \cot \theta
 \end{aligned}$$

Substituting the value of *W* in equation (i), we get

$$P = \frac{wh^2}{2} \cot \theta \cdot \tan(\theta - \phi) \quad \dots(ii)$$

In the above equation the angle  $\theta$  is the angle of the rupture plane. The earth is having maximum tendency to slip along rupture plane. Hence the supposing force *P* should be maximum. But *P* will be maximum if  $\frac{dP}{d\theta} = 0$ .

Hence differentiating equation (ii), w.r.t.  $\theta$ , we get

$$\frac{dp}{d\theta} = \frac{d}{d\theta} \left[ \frac{wh^2}{2} \cot \theta \cdot \tan (\theta - \phi) \right] = 0$$

$$\begin{aligned}
 \text{or } \frac{wh^2}{2} (\cot \theta \sec^2 (\theta - \phi) - \operatorname{cosec}^2 \theta \tan (\theta - \phi)) &= 0 \\
 \text{or } \cot \theta \sec^2 (\theta - \phi) - \operatorname{cosec}^2 \theta \tan (\theta - \phi) &= 0 \quad \dots(iii)
 \end{aligned}$$

Let  $\tan \theta = t$  and  $\tan (\theta - \phi) = t_1$ .

The equation (iii) becomes as

$$\frac{1}{t} (1 + t_1^2) - \left( 1 + \frac{1}{t^2} \right) \times t_1 = 0 \quad \left\{ \because \cot \theta = \frac{1}{\tan \theta} = \frac{1}{t} \text{ and } \operatorname{cosec}^2 \theta = 1 + \cot^2 \theta = 1 + \frac{1}{t^2} \right\}$$

$$\text{or } \frac{1 + t_1^2}{t} - \left( \frac{t^2 + 1}{t^2} \right) \times t_1 = 0$$

$$\text{or } t(1 + t_1^2) - (t^2 + 1) \times t_1 = 0$$

$$\text{or } t + t t_1^2 - t_1 t^2 - t_1 = 0$$

$$\text{or } t - t_1 t^2 + t t_1^2 - t_1 = 0$$

$$\text{or } t[1 - t_1 t] - t_1[1 - t t_1] = 0$$

$$\text{or } (1 - t_1 t)(t - t_1) = 0$$

Either  $(1 - t_1 t) = 0$  or  $(t - t_1) = 0$

$\therefore t t_1 = 1$  or  $t = t_1$

If  $t = t_1$ , then  $\theta = \tan (\theta - \phi)$ .

This is not possible

$$\therefore t t_1 = 1$$

$$\text{or } \tan \theta \tan (\theta - \phi) = 1$$

$$\text{or } \tan \theta = \frac{1}{\tan (\theta - \phi)}$$

$$= \cot (\theta - \phi) = \tan [90 - (\theta - \phi)]$$

$$\therefore \theta = 90 - (\theta - \phi)$$

$$\text{or } \theta + \theta - \phi = 90^\circ$$

$$\text{or } 2\theta - \phi = 90^\circ$$

$$\therefore \theta = \frac{90 + \phi}{2} = 45^\circ + \frac{\phi}{2}$$

Thus the plane of rupture is inclined at  $\left( 45^\circ + \frac{\phi}{2} \right)$  with the horizontal.

Substituting the value of  $\theta$  in equation (ii), we get

$$P = \frac{wh^2}{2} \cot \theta \cdot \tan (\theta - \phi) = \frac{wh^2}{2} \frac{\tan (\theta - \phi)}{\tan \theta}$$

$$\begin{aligned}
 &= \frac{wh^2}{2} \frac{\tan\left(45^\circ + \frac{\phi}{2} - \phi\right)}{\tan\left(45^\circ + \frac{\phi}{2}\right)} \quad \left(\because \theta = 45^\circ + \frac{\phi}{2}\right) \\
 &= \frac{wh^2}{2} \frac{\tan\left(45^\circ - \frac{\phi}{2}\right)}{\tan\left(45^\circ + \frac{\phi}{2}\right)} \\
 &= \frac{wh^2}{2} \left( \frac{\tan 45^\circ - \tan \frac{\phi}{2}}{1 + \tan 45^\circ \tan \frac{\phi}{2}} \right) \times \left( \frac{1 - \tan 45^\circ \tan \frac{\phi}{2}}{\tan 45^\circ + \tan \frac{\phi}{2}} \right) \\
 &= \frac{wh^2}{2} \left( \frac{1 - \tan \frac{\phi}{2}}{1 + \tan \frac{\phi}{2}} \right) \times \left( \frac{1 - \tan \frac{\phi}{2}}{1 + \tan \frac{\phi}{2}} \right) \quad (\because \tan 45^\circ = 1) \\
 &= \frac{wh^2}{2} \left( \frac{1 - \tan \frac{\phi}{2}}{1 + \tan \frac{\phi}{2}} \right)^2 = \frac{wh^2}{2} \left( \frac{1 - \frac{\sin \frac{\phi}{2}}{\cos \frac{\phi}{2}}}{1 + \frac{\sin \frac{\phi}{2}}{\cos \frac{\phi}{2}}} \right)^2 \\
 &= \frac{wh^2}{2} \left( \frac{\cos \frac{\phi}{2} - \sin \frac{\phi}{2}}{\cos \frac{\phi}{2} + \sin \frac{\phi}{2}} \right)^2 \\
 &= \frac{wh^2}{2} \left( \frac{\cos^2 \frac{\phi}{2} + \sin^2 \frac{\phi}{2} - 2 \cos \frac{\phi}{2} \sin \frac{\phi}{2}}{\cos^2 \frac{\phi}{2} + \sin^2 \frac{\phi}{2} + 2 \cos \frac{\phi}{2} \sin \frac{\phi}{2}} \right) \\
 &= \frac{wh^2}{2} \left( \frac{1 - 2 \cos \frac{\phi}{2} \sin \frac{\phi}{2}}{1 + 2 \cos \frac{\phi}{2} \sin \frac{\phi}{2}} \right) \\
 \therefore P &= \frac{wh^2}{2} \left( \frac{1 - \sin \phi}{1 + \sin \phi} \right) \quad \dots(10.19)
 \end{aligned}$$

But  $P$  is the horizontal force exerted by the retaining wall on the wedge. The wedge of the earth will also exert the same horizontal force on the retaining wall. Hence equation (10.19) gives also horizontal force exerted by the earth on the retaining wall.

The horizontal force  $P$  acts at a height of  $\frac{h}{3}$  above the base.

**Pressure intensity at the bottom.** If we assume a linear variation of the pressure intensity varying from zero at the top to the maximum value  $p$  at the bottom, then we have

$$P = \frac{p \times h}{2}$$

But from equation (10.19),

$$P = \frac{wh^2}{2} \left[ \frac{1 - \sin \phi}{1 + \sin \phi} \right]$$

Equating the two values of  $P$ , we get

$$\therefore \frac{p \times h}{2} = \frac{wh^2}{2} \left[ \frac{1 - \sin \phi}{1 + \sin \phi} \right]$$

$$\text{or} \quad p = wh \left[ \frac{1 - \sin \phi}{1 + \sin \phi} \right] \quad \dots(10.20)$$

**Problem 10.15.** A masonry retaining wall of trapezoidal section is 6 metre high and retains earth which is level upto the top. The width at the top is 1 m and the exposed face is vertical. Find the minimum width of the wall at the bottom in order the tension may not be induced at the base. The density of masonry and earth is 2300 and 1600 kg/m<sup>3</sup> respectively. The angle of repose of the soil is 30°.

**Sol. Given :**

Height of wall,  $h = 6$  m

Width at the top,  $a = 1$  m

Density of masonry,  $\rho_0 = 2300$  kg/m<sup>3</sup>

$\therefore$  Weight density of masonry

$$w_0 = \rho_0 \times g = 2300 \times 9.81 \text{ N/m}^3$$

Density of earth,  $\rho = 1600$  kg/cm<sup>3</sup>

$\therefore$  Weight density of earth,  $w = \rho \times g = 1600 \times 9.81 \text{ N/m}^3$

Angle of repose,  $\phi = 30^\circ$

Let  $b =$  Minimum width at the bottom.

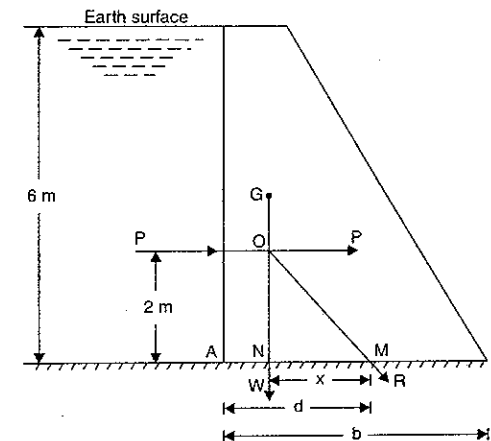

Fig. 10.21



Consider one metre length of the retaining wall.

The thrust of earth on the vertical face is given by equation (10.19),

$$\begin{aligned} P &= \frac{1}{2} wh^2 \left( \frac{1 - \sin \phi}{1 + \sin \phi} \right) \\ &= \frac{1}{2} \times 1600 \times 9.81 \times 6^2 \left( \frac{1 - \sin 30^\circ}{1 + \sin 30^\circ} \right) \\ &= 800 \times 9.81 \times 36 \left( \frac{1 - 0.5}{1 + 0.5} \right) = \frac{800 \times 9.81 \times 36 \times 0.5}{1.5} \\ &= 94176 \text{ N.} \end{aligned}$$

The thrust  $P$  will be acting at a height of  $\frac{6}{3} = 2$  m above the base. Weight of 1 m length of trapezoidal wall,

$$\begin{aligned} W &= \text{Weight density of masonry} \times \text{Area of trapezoidal} \times 1 \\ &= 2300 \times 9.81 \times \left( \frac{a+b}{2} \right) \times h \times 1 \\ &= 2300 \times 9.81 \times \left( \frac{1+b}{2} \right) \times 6 = 67689(1+b) \text{ N.} \end{aligned}$$

The weight  $W$  will be acting through the C.G. of the trapezoidal section. The distance of the C.G. of the trapezoidal from the point  $A$  is obtained by using equation (10.8).

$$\begin{aligned} AN &= \frac{a^2 + ab + b^2}{3(a+b)} \\ &= \frac{1^2 + 1 \times b + b^2}{3(1+b)} = \frac{1+b+b^2}{3(1+b)} \end{aligned}$$

The horizontal distance  $x$ , between the line of action of  $W$  and the point at which the resultant force  $R$  cuts the base, is given by equation (10.3).

$$\begin{aligned} \therefore x &= \frac{P}{W} \times \frac{h}{3} & (\because \text{Here } P = F) \\ &= \frac{94176}{67689(1+b)} \times \frac{6}{3} = \frac{2.782}{(1+b)} \end{aligned}$$

Hence in Fig. 10.21,  $d = AN + x$

$$\begin{aligned} &= \frac{1+b+b^2}{3(1+b)} + \frac{2.782}{(1+b)} \\ &= \frac{1+b+b^2 + 3 \times 2.782}{3(1+b)} = \frac{1+b+b^2 + 8.346}{3(1+b)} \\ &= \frac{b^2 + b + 9.346}{3(1+b)} \end{aligned}$$

If the tension at the base is just avoided,

$$d = \frac{2}{3} b$$

$$\text{or } \frac{b^2 + b + 9.346}{3(1+b)} = \frac{2}{3} b$$

$$\text{or } b^2 + b + 9.346 = 2b(1+b) = 2b + 2b^2$$

$$\text{or } b^2 + b - 9.346 = 0$$

The above equation is quadratic equation. Its solution is given by

$$\begin{aligned} b &= \frac{-1 \pm \sqrt{1^2 + 4 \times 1 \times 9.346}}{2} = \frac{-1 \pm 6.195}{2} \\ &= \frac{-1 + 6.195}{2} & (\text{Neglecting - ve value}) \\ &= 2.597 \text{ m. Ans.} \end{aligned}$$

**Problem 10.16.** A masonry retaining wall of trapezoidal section is 10 m high and retains earth which is level upto the top. The width at the top is 2 m and at the bottom 8 m and the exposed face is vertical. Find the maximum and minimum intensities of normal stress at the base.

Take : Density of earth = 1600 kg/m<sup>3</sup>,  
Density of masonry = 2400 kg/m<sup>3</sup>,  
Angle of repose of earth = 30°.

(AMIE, Winter 1984)

**Sol. Given :**

Height of wall,  $h = 10$  m  
Width of wall at top,  $a = 2$  m  
Width at the bottom,  $b = 8$  m  
Density of earth,  $\rho = 1600$  kg/m<sup>3</sup>

$\therefore$  Weight density of earth,

$$w = \rho \times g = 1600 \times 9.81 \text{ N/m}^3$$

Density of masonry,  $\rho_0 = 2400$  kg/cm<sup>3</sup>

$\therefore$  Weight density of masonry,

$$w_0 = \rho_0 \times g = 2400 \times 9.81 \text{ N/m}^3$$

Angle of repose,  $\phi = 30^\circ$

Consider 1 m length of the wall.

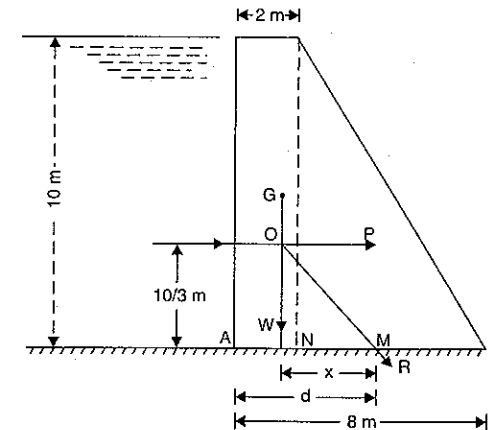

Fig. 10.22

Thrust of earth on the vertical face of the wall is given by equation (10.19),

$$P = \frac{1}{2} wh^2 \left( \frac{1 - \sin \phi}{1 + \sin \phi} \right)$$

$$\begin{aligned}
 &= \frac{1}{2} \times 1600 \times 9.81 \times 10^2 \left( \frac{1 - \sin 30^\circ}{1 + \sin 30^\circ} \right) \\
 &= 800 \times 9.81 \times 100 \left( \frac{1 - 0.5}{1 + 0.5} \right) \\
 &= 80000 \times 9.81 \times \frac{0.5}{1.5} = \frac{80000 \times 9.81}{3} \text{ N.}
 \end{aligned}$$

The thrust  $P$  will be acting at a height of  $\frac{10}{3}$  m above the ground. Weight of 1 m length of trapezoidal wall.

$$\begin{aligned}
 W &= \text{Weight density of masonry} \times \text{Volume of wall} \\
 &= 2400 \times 9.81 \times [\text{Area of cross-section of trapezoidal wall}] \times 1 \\
 &= 2400 \times 9.81 \times \left( \frac{8+2}{2} \right) \times 10 \times 1 \quad \left[ \because \text{Area} = \left( \frac{8+2}{2} \right) \times 10 \text{ m}^2 \right] \\
 &= 120000 \times 9.81 \text{ N.}
 \end{aligned}$$

The weight  $W$  will be acting through the C.G. of the trapezoidal section. The distance of the C.G. of the trapezoidal section from the point  $A$  is obtained by using equation (10.8).

$$\begin{aligned}
 AN &= \frac{a^2 + ab + b^2}{3(a+b)} \\
 &= \frac{2^2 + 2 \times 8 + 8^2}{3(2+8)} = \frac{4 + 16 + 64}{30} = \frac{84}{30} = 2.8 \text{ m.}
 \end{aligned}$$

The horizontal distance  $x$  between the line of action of  $W$  and the point at which the resultant force  $R$  cuts the base, is given by equation (10.3).

$$\begin{aligned}
 \therefore x &= \frac{P}{W} \times \frac{h}{3} \quad (\because \text{Here } P = F) \\
 &= \frac{80000 \times 9.81}{3 \times 120000 \times 9.81} \times \frac{10}{3} = 0.74 \text{ m}
 \end{aligned}$$

Hence in Fig. 10.22,  $d = AN + x$   
 $= 2.8 + 0.74 = 3.54 \text{ m}$

$\therefore$  Eccentricity,  $e = d - \frac{b}{2}$   
 $= 3.54 - \frac{8}{2} = 3.54 - 4.0 = -0.46 \text{ m}$

(Minus sign only indicates that stress at  $A$  will be more than at  $B$ ).

The maximum and minimum stresses at the base are given by equations (10.10) and (10.11).

$$\begin{aligned}
 \therefore \text{Stresses } (\sigma_{max} \text{ and } \sigma_{min}) &= \frac{W}{b} \left( 1 \pm \frac{6 \cdot e}{b} \right) \\
 &= \frac{120000 \times 9.81}{8} \left( 1 \pm \frac{6 \times 0.46}{8} \right) = 147150 (1 \pm 0.345) \\
 &= 147150 \times 1.345 \text{ and } 147150 \times (1 - 0.345) \\
 &= 197916.75 \text{ N/m}^2 \text{ and } 96383.25 \text{ N/m}^2 \\
 \therefore \sigma_{max} &= 197916.75 \text{ N/m}^2 \text{ and is acting at } A. \quad \text{Ans.} \\
 \sigma_{min} &= 96383.25 \text{ N/m}^2 \text{ and is acting at } B. \quad \text{Ans.}
 \end{aligned}$$

**Problem 10.17.** A masonry retaining wall of trapezoidal section is 1.5 m wide at the top, 3.5 m wide at the base and 6 m high. The face of the wall retaining earth is vertical and the earth level is upto the top of the wall. The density of the earth is 1600 kg/m<sup>3</sup> for the top 3 m and 1800 kg/m<sup>3</sup> below this level. The density of masonry is 2300 kg/m<sup>3</sup>. Find the total lateral pressure on the retaining wall per m run and maximum and minimum normal pressure intensities at the base. Take the angle of repose = 30° for both types of earth.

- Sol. Given :**
- Width at the top,  $a = 1.5 \text{ m}$
  - Width at the bottom,  $b = 3.5 \text{ m}$
  - Height of the wall,  $h = 6 \text{ m}$
  - Density of upper earth,  $\rho_1 = 1600 \text{ kg/m}^3$
  - $\therefore$  Weight density of upper earth,  $w_1 = 1600 \times 9.81 \text{ N/m}^3$
  - Depth of upper earth,  $h_1 = 3 \text{ m}$
  - Density of lower earth,  $\rho_2 = 1800 \text{ kg/m}^3$
  - $\therefore$  Weight density of lower earth,  $w_2 = 1800 \times 9.81 \text{ N/m}^3$
  - Depth of lower earth,  $h_2 = 3 \text{ m}$
  - Density of masonry,  $\rho_0 = 2300 \text{ kg/m}^3$
  - $\therefore$  Weight density of masonry,  $w_0 = 2300 \times 9.81 \text{ N/m}^3$
  - Angle of repose for both earth,  $\phi = 30^\circ$ .

**Total lateral pressure on the retaining wall per m run**

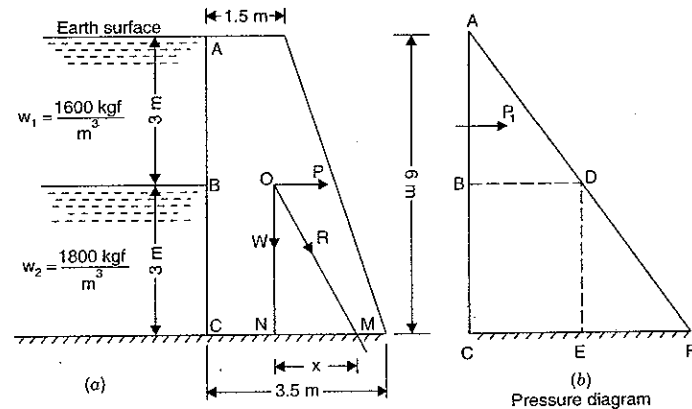

Fig. 10.23

The pressure diagram on the retaining wall is shown in Fig. 10.23 (b)

- Let  $P$  = Total lateral pressure force  
 $P_1$  = Pressure force due to upper earth.  
 $P_2$  = Pressure force due to lower earth.

The pressure intensity at a depth  $h$  is given by equation (10.20) as

$$p = wh \left[ \frac{1 - \sin \phi}{1 + \sin \phi} \right]$$

$\therefore$  Pressure intensity at  $B$ ,

$$\begin{aligned} p_B &= w_1 h_1 \left( \frac{1 - \sin 30^\circ}{1 + \sin 30^\circ} \right) = 1600 \times 9.81 \times 3 \left( \frac{1 - 0.5}{1 + 0.5} \right) \\ &= 4800 \times 9.81 \times \frac{0.5}{1.5} = 1600 \times 9.81 \text{ N/m}^2. \end{aligned}$$

This is represented by length  $BD$  in pressure diagram.

$\therefore$  Length  $BD = p_B = 1600 \times 9.81 \text{ N/m}^2$

Similarly pressure intensity at  $C$ ,

$$\begin{aligned} p_C &= p_B + w_2 h_2 \left[ \frac{1 - \sin \phi}{1 + \sin \phi} \right] \\ &= 1600 \times 9.81 + 1800 \times 9.81 \times 3 \times \left( \frac{1 - 0.5}{1 + 0.5} \right) \\ &= 1600 \times 9.81 + 1800 \times 9.81 \text{ N.} \end{aligned}$$

This is represented by length  $CF$  in pressure diagram

$\therefore$   $CF = 1600 \times 9.81 + 1800 \times 9.81 = 3400 \times 9.81 \text{ N/m}^2$

But  $CE = BD = 1600 \times 9.81$

$\therefore$   $EF = CF - CE$

$$= (1600 + 1800) \times 9.81 - 1600 \times 9.81 = 1800 \times 9.81 \text{ N/m}^2$$

$\therefore$  Pressure force due to upper earth,

$$\begin{aligned} P_1 &= \text{Area of triangle } ABD \\ &= \frac{1}{2} \times AB \times BD = \frac{1}{2} \times 3 \times 1600 \times 9.81 = 23544 \text{ N} \end{aligned}$$

This force acts at a height of  $\frac{1}{3} \times 3 = 1 \text{ m}$  above  $B$  or at a height of  $(3 + 1) = 4 \text{ m}$  above point  $C$ .

Pressure force due to lower earth,

$$\begin{aligned} P_2 &= \text{Area of } BDFC = \frac{1}{2} [BD + CF] \times BC \\ &= \frac{1}{2} [1600 + 3400] \times 9.81 \times 3.0 = 73575 \text{ N.} \end{aligned}$$

This force acts at a height from  $C$

$$\begin{aligned} &= [\text{Area of rectangle } CEDB \times \frac{3}{2} \\ &\quad + \text{Area of triangle } EFD \times 1] \div \text{Total area} \\ &= \frac{1600 \times 9.81 \times 3 \times \frac{3}{2} + \frac{1800 \times 9.81 \times 3}{2} \times 1}{1600 \times 9.81 \times 3 + \frac{1800 \times 9.81 \times 3}{2}} \\ &= \frac{9.81 \times 7200 + 2700 \times 9.81}{9.81 \times 4800 + 2700 \times 9.81} = \frac{9900}{7500} = 1.32 \text{ m from } C. \end{aligned}$$

$\therefore$  Total pressure force,

$$P = P_1 + P_2 = 23544 + 73575 = 97119 \text{ N. Ans.}$$

**Maximum and minimum normal stresses at base**

Weight of retaining wall per m run,

$$\begin{aligned} W &= \text{Weight density of masonry} \times \left( \frac{a+b}{2} \right) \times h \times 1 \\ &= 2300 \times 9.81 \times \left( \frac{1.5+3.5}{2} \right) \times 6 \times 1 = 338445 \text{ N.} \end{aligned}$$

The weight  $W$  will be acting at the C.G. of the retaining wall. The distance of the C.G. of the retaining wall from point  $C$  is given by equation (10.8) as,

$$CN = \frac{a^2 + ab + b^2}{3(a+b)} = \frac{1.5^2 + 1.5 \times 3.5 + 3.5^2}{3(1.5+3.5)} = 1.32 \text{ m}$$

Let  $x$  = Distance between the line of action of  $W$  and the resultant of  $W$  and  $P$  at the base.

Taking moments of  $W$ ,  $P_1$  and  $P_2$  about the point  $M$ , we get

$$P_1 \times 4 + P_2 \times 1.32 = W \times x$$

$$\begin{aligned} \therefore x &= \frac{P_1 \times 4 + P_2 \times 1.32}{W} \\ &= \frac{23544 \times 4 + 73575 \times 1.32}{338445} = \frac{94176 + 97119}{338445} = 0.565 \text{ m} \end{aligned}$$

$\therefore$  Distance  $CM = CN + x = 1.32 + 0.565 = 1.885 \text{ m}$

$\therefore$  Eccentricity,  $e = CM - \frac{b}{2} = 1.885 - \frac{3.5}{2} = 0.135 \text{ m.}$

Now using equations (10.10) and (10.11), we get

$$\begin{aligned} \sigma_{max} &= \frac{W}{b} \left( 1 + \frac{6 \cdot e}{b} \right) \\ &= \frac{338445}{3.5} \left( 1 + \frac{6 \times 0.135}{3.5} \right) = 119073.78 \text{ N/m}^2. \text{ Ans.} \end{aligned}$$

and

$$\begin{aligned} \sigma_{min} &= \frac{W}{b} \left( 1 - \frac{6 \cdot e}{b} \right) \\ &= \frac{338445}{3.5} \left( 1 - \frac{6 \times 0.135}{3.5} \right) = 74320.56 \text{ N/m}^2. \text{ Ans.} \end{aligned}$$

## 10.9. SURCHARGED RETAINING WALL

Fig. 10.24 shows a retaining wall of height  $h$  and retaining earth which is surcharged at an angle  $\alpha$  with the horizontal. Then the total earth pressure exerted on the retaining wall is given by,

$$P^* = \frac{wh^2}{2} \cos \alpha \cdot \frac{\cos \alpha - \sqrt{\cos^2 \alpha - \cos^2 \phi}}{\cos \alpha + \sqrt{\cos^2 \alpha + \cos^2 \phi}} \quad \dots(10.21)$$

where  $\phi$  = Angle of repose.

\*The proof of this expression may be seen in some standard book of theory of structure.

The total earth pressure  $P$  acts at a height of  $\frac{h}{3}$  above the base of the retaining wall and parallel to the free surface of the earth.

The pressure  $P$  is resolved into two components i.e., horizontal and vertical components.

The horizontal component,  $P_H = P \cos \alpha$  and acts at a height of  $\frac{h}{3}$  above base.

The vertical component,  $P_V = P \sin \alpha$  and acts along  $DA$ .

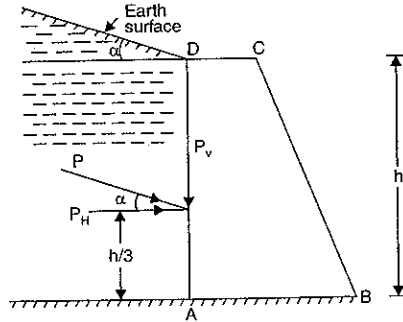

Fig. 10.24

**Problem 10.18.** A masonry retaining wall of trapezoidal section 2 m wide at its top, 3 m wide at its bottom is 8 m high. It is retaining a soil on its vertical side at a surcharge of  $20^\circ$ . The soil has a density of  $2000 \text{ kg/m}^3$  and has an angle of repose of  $45^\circ$ . Find the total pressure on the wall per metre length and the point, where the resultant cuts the base.

Also find maximum and minimum intensities of stress at the base. Take density of the masonry as  $2400 \text{ kg/m}^3$ .

**Sol. Given :**

- Top width,  $a = 2 \text{ m}$
- Base width,  $b = 3 \text{ m}$
- Height of wall,  $h = 8 \text{ m}$
- Angle of surcharge,  $\alpha = 20^\circ$
- Density of soil,  $\rho = 2000 \text{ kg/m}^3$
- $\therefore$  Specific weight of soil,  $w = 2000 \times 9.81 \text{ N/m}^3$
- Angle of repose,  $\phi = 45^\circ$
- Density of masonry,  $\rho_0 = 2400 \text{ kg/m}^3$
- $\therefore$  Weight density of masonry,  $w_0 = \rho_0 \times g = 2400 \times 9.81 \text{ N/m}^3$

**Total pressure on the wall per metre length**

Let  $P$  = Total pressure on the wall per metre length.

Using equation (10.21),

$$P = \frac{wh^2}{2} \cos \alpha \frac{\cos \alpha - \sqrt{\cos^2 \alpha - \cos^2 \phi}}{\cos \alpha + \sqrt{\cos^2 \alpha + \cos^2 \phi}}$$

$$P = \frac{2000 \times 9.81(8)^2}{2} \cos 20^\circ \times \frac{\cos 20^\circ - \sqrt{\cos^2 20^\circ - \cos^2 45^\circ}}{\cos 20^\circ + \sqrt{\cos^2 20^\circ + \cos^2 45^\circ}} \text{ N}$$

$$= 64000 \times 9.81 \times 0.9397 \times \frac{0.9397 - \sqrt{0.9397^2 - 0.7071^2}}{0.9397 + \sqrt{0.9397^2 + 0.7071^2}} \text{ N}$$

$$= 627840 \text{ N. Ans.}$$

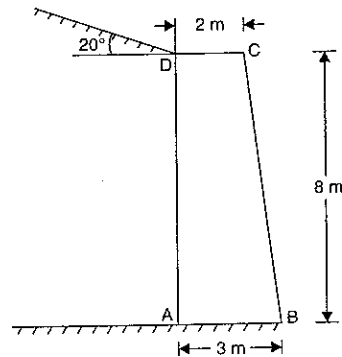

Fig. 10.25

**The point, where the resultant cuts the base**

Let the resultant cut the base at  $M$  as shown in Fig. 10.26.

Let  $x$  = Horizontal distance between the c.g. of the vertical load of wall and  $M$  (i.e.,  $NM$ ).

We know that the horizontal component, of the pressure,

$$P_H = 627840 \cos 20^\circ \text{ N}$$

$$= 627840 \times 0.9397 \text{ N} = 114090.3 \text{ N}$$

and vertical component of the pressure,

$$P_V = 627840 \sin 20^\circ \text{ N}$$

$$= 627840 \times 0.3420 \text{ N} = 41535.54 \text{ N}$$

Weight of dam

$$= w_0 \times \left( \frac{a+b}{2} \right) \times h$$

$$= 2400 \times 9.81 \times \left( \frac{2+3}{2} \right) \times 8 = 470880 \text{ N}$$

$\therefore$  Total load acting vertically down,

$$W = 470880 + 41535.54 = 512415.54 \text{ N.}$$

First of all, let us find out the position of c.g. of the vertical load. Taking moments of the vertical loads about  $A$  and equating the same,

$$W \times AN = P_V \times 0 + 2400 \times 9.81 \times 2 \times 8 \times 1 + 2400 \times 9.81 \times \frac{8 \times 1}{2} \times \frac{7}{3}$$

$$\therefore 512415.54 AN = 60,8000 \times 9.81$$

or  $AN = \frac{60,8000 \times 9.81}{512415.54} = 1.164 \text{ m}$

Now using the relation,

$$x = \frac{P_H}{W} \times \frac{h}{3} \text{ with usual notations.}$$

$$= \frac{114090.3}{512415.54} \times \frac{8}{3} = 0.594 \text{ m}$$

or Distance  $NM = x = 0.594 \text{ m.}$

$\therefore$  Horizontal distance between  $A$  and the point  $M$ , where the resultant cuts the base,

$$d = AN + NM = 1.164 + 0.594 \text{ m} = 1.758 \text{ m. Ans.}$$

**Maximum and minimum intensities of stress at the base**

Let  $\sigma_{max}$  = Maximum intensity of stress at the base.

$\sigma_{min}$  = Minimum intensity of stress at the base.

We know that the eccentricity of the resultant,

$$e = d - \frac{b}{2} = 1.758 - \frac{3}{2} = 0.258 \text{ m}$$

Using the relation,  $\sigma_{max} = \frac{W}{b} \left( 1 + \frac{6 \cdot e}{b} \right)$

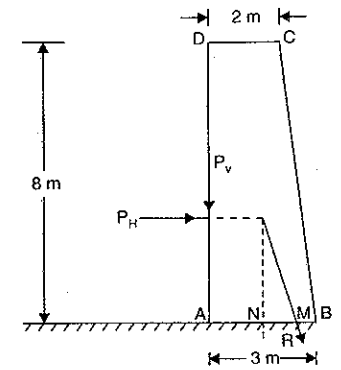

Fig. 10.26

$$= \frac{512415.54}{3} \left( 1 + \frac{6 \times 0.258}{3} \right) \text{ N/m}^2 = 259082.1 \text{ N/m}^2$$

Now using the relation,

$$\begin{aligned} \sigma_{min} &= \frac{W}{b} \left( 1 - \frac{6 \cdot e}{b} \right) \\ &= \frac{512415.54}{3} \left( 1 - \frac{6 \times 0.258}{3} \right) \text{ N/m}^2 = 82659.06 \text{ N/m}^2. \quad \text{Ans.} \end{aligned}$$

### 10.10 CHIMNEYS

Chimneys are tall structures subjected to horizontal wind pressure. The base of the chimneys are subjected to bending moment due to horizontal wind force. This bending moment at the base produces bending stresses. The base of the chimney is also subjected to direct stresses due to self weight of the chimney. Hence at the base of the chimney, the bending stress and direct stress are acting. The direct stress  $\sigma_0$  is given by,

$$\sigma_0 = \frac{\text{Weight of chimney}}{\text{Area of section at the base}} = \frac{W}{A}$$

The bending stress ( $\sigma_b$ ) is obtained from

$$\frac{M}{I} = \frac{\sigma_b}{y}$$

$$\text{or} \quad \sigma_b = \frac{M}{I} \times y = \frac{M}{(I/y)} = \frac{M}{Z} \quad \dots(10.22)$$

where  $M$  = Bending moment due to horizontal wind force and

$Z$  = Modulus of section.

The wind force ( $F$ ) acting in the horizontal direction on the surface of chimney is given by,

$$F = K \times p \times A \quad \dots[10.22 (A)]$$

where  $K$  = co-efficient of wind resistance, which depends upon the shape of the area exposed to wind.

= 1 for rectangular and square chimneys

=  $\frac{2}{3}$  for circular chimney

$p$  = intensity of wind pressure

$A$  = projected area of the surface exposed to wind.

=  $D \times h$  for circular chimney

=  $b \times h$  for rectangular or square chimney

$b$  = width of chimney exposed to wind

$h$  = height of chimney.

The wind force  $F$  will be acting at  $\frac{h}{2}$ .

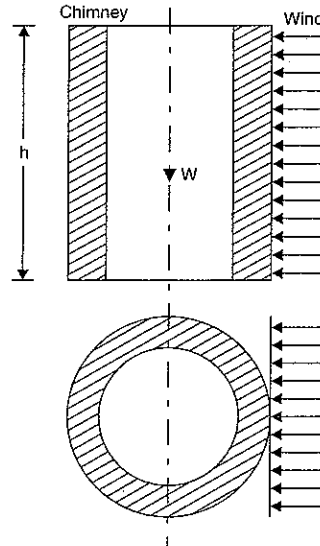

Fig. 10.27. Chimney subjected to wind force.

The moment of  $F$  at the base of the chimney will be  $F \times \frac{h}{2}$ .

Hence bending moment ( $M$ ) at the base of chimney is given by,

$$M = F \times \frac{h}{2}$$

**Problem 10.19.** Determine the maximum and minimum stresses at the base of an hollow circular chimney of height 20 m with external diameter 4 m and internal diameter 2 m. The chimney is subjected to a horizontal wind pressure of intensity 1 kN/m<sup>2</sup>. The specific weight of the material of chimney is 22 kN/m<sup>3</sup>.

**Sol.** Given :

Height,  $H = 20$  m ; External dia,  $D = 4$  m ; Internal dia,  $d = 2$  m.

Horizontal wind pressure,  $p = 1$  kN/m<sup>2</sup>

Specific weight,  $w = 22$  kN/m<sup>3</sup>

Let us first find the weight of the chimney and horizontal wind force ( $F$ ).

Weight ( $W$ ) of the chimney is given by,

$$\begin{aligned} W &= \rho \times g \times \text{Volume of chimney} \\ &= \text{Weight density} \times \text{Volume of chimney} \\ &= w \times [\text{Area of cross-section}] \times \text{height} \\ &= 22 \times \left[ \frac{\pi}{4} (D^2 - d^2) \right] \times h \text{ kN} \\ &= 22 \times \frac{\pi}{4} (4^2 - 2^2) \times 20 \text{ kN} = 4146.9 \text{ kN} \end{aligned}$$

$\therefore$  Direct stress at the base of the chimney,

$$\begin{aligned} \sigma_0 &= \frac{W}{A} \quad \text{where } A = \text{Area of cross-section} \\ &= \frac{4146.9}{\frac{\pi}{4} (4^2 - 2^2)} = \frac{4146.9}{3\pi} = 440 \text{ kN/m}^2 \end{aligned}$$

Now let us find the wind force ( $F$ ). This force is given by equation [10.22(A)].

$$\therefore F = K \times p \times A$$

where  $K = \frac{2}{3}$  as the section is circular

$A$  = projected area of the surface exposed to wind

=  $D \times h$  where  $D$  = External dia = 4 m

=  $4 \times 20 = 80$  m<sup>2</sup>

$p$  = horizontal wind pressure = 1 kN/m<sup>2</sup>

$$\therefore F = \frac{2}{3} \times 1 \times 80 = \frac{160}{3} = 53.33 \text{ kN}$$

The bending moment ( $M$ ) at the base,

$$M = F \times \frac{h}{2} = 53.33 \times \frac{20}{2} = 533.3 \text{ kNm}$$

The bending stress ( $\sigma_b$ ) is given by equation (10.22) as

$$\sigma_b = \frac{M}{Z} \quad \text{where } Z = \text{section modulus} = \frac{I}{y}$$

$$I = \frac{\pi}{64} (D^4 - d^4), y = \frac{D}{2}$$

$$I = \frac{\pi}{64} [4^4 - 2^4] = 11.78 \text{ m}^4 \quad \text{and} \quad y = \frac{4}{2} = 2 \text{ m.}$$

$$Z = \frac{I}{y} = \frac{11.78}{2} = 5.89 \text{ m}^3$$

$$\sigma_b = \frac{533.3}{5.89} = 90.54 \text{ kN/m}^2$$

∴ Now the maximum and minimum stresses at the base are given by,

$$\sigma_{max} = \sigma_0 + \sigma_b = 440 + 90.54 = 530.54 \text{ kN/m}^2 \text{ (comp)}$$

$$\sigma_{min} = \sigma_0 - \sigma_b = 440 - 90.54 = 349.46 \text{ kN/m}^2 \text{ (comp). Ans.}$$

and

### HIGHLIGHTS

1. A dam is constructed to store water whereas a retaining wall is constructed to retain the earth.
2. Trapezoidal dams, as compared to rectangular dams, are economical and easier to construct.
3. Thrust due to water on the vertical side of a dam is given by

$$F = \frac{wh^2}{2}$$

where  $w$  = Weight density of water =  $1000 \times 9.81 \text{ N/m}^3$

$h$  = Depth of water.

4. The horizontal distance between the line of action of  $W$  and the point through which the resultant cuts the base is given by

$$x = \frac{F}{W} \times \frac{h}{3}$$

where  $F$  = Force exerted by water,  $W$  = Weight of dam and

$h$  = Depth of water.

5. The eccentricity is given by,

$$e = d - \frac{b}{2}$$

where  $d$  = The distance between  $A$  and the point where the resultant  $R$  cuts the base

$$= \frac{b}{2} + \frac{F \times h}{W \times 3} \quad \dots \text{For a rectangular dam}$$

$$= AN + \frac{F \times h}{W \times 3} \quad \dots \text{For a trapezoidal dam}$$

and  $b$  = Base width of the dam.

6. The position of the C.G. of the dam from the point  $A$  is given by,

$$AD = \frac{b}{2} \quad \dots \text{For a rectangular dam}$$

$$= \frac{a^2 + ab + b^2}{3(a+b)} \quad \dots \text{For a trapezoidal dam}$$

where  $a$  = Top width of the dam, and

$b$  = Bottom width of the dam.

7. The maximum and minimum stresses at the base of a dam having water face vertical are given by,

$$\sigma_{max} = \frac{W}{b} \left( 1 + \frac{6 \cdot e}{b} \right)$$

and

$$\sigma_{min} = \frac{W}{b} \left( 1 - \frac{6 \cdot e}{b} \right)$$

where  $W$  = Weight of the dam

$$= w_0 \times b \times H \times 1 \quad \dots \text{For a rectangular dam}$$

$$= w_0 \times \left( \frac{\alpha + b}{2} \right) \times H \times 1 \quad \dots \text{For a trapezoidal dam}$$

$b$  = Bottom width of dam, and

$e$  = Eccentricity.

8. If the reservoir is empty, then the only force acting on the dam is the weight of the dam.
9. In case of a trapezoidal dam, if water face is inclined, then the force due to water acting on the inclined face is resolved into two components. The components in the  $x$ -direction and  $y$ -directions are given by,

$F_x$  = Force exerted by water on the vertical face

and  $F_y$  = Weight of the water included with the vertical face and inclined face.

10. The maximum and minimum stresses induced at the base of a trapezoidal dam having water face inclined are given by,

$$\sigma_{max} = \frac{W}{b} \left( 1 + \frac{6 \cdot e}{b} \right)$$

and

$$\sigma_{min} = \frac{W}{b} \left( 1 - \frac{6 \cdot e}{b} \right)$$

where  $V$  = Sum of the forces acting on the dam =  $F_y + W$ .

where  $W$  = Weight of dam

and  $F_y$  = Weight of water included with the vertical face and inclined face.

11. If the force of friction is more than the force due to water pressure, there will be no sliding of the dam. But force of friction is equal to  $\mu \times W$ , where  $\mu$  is the co-efficient of friction between the base of the dam and the soil and  $W$  = weight of dam.
12. There will be no overturning of the dam if the resultant of water pressure and weight of dam strikes the base within its width.
13. There will be no tension in the masonry of the dam at its base if

$$e \leq \frac{b}{6} \quad \text{or} \quad d \leq \frac{2}{3} b$$

where  $e$  = Eccentricity,

$b$  = Base width,

and  $d$  = Distance between the point  $A$  and the point through which resultant force meets the base.

14. The pressure exerted by earth on the retaining wall is given by Rankine's theory of earth pressure. According to this theory the pressure exerted by earth, which is level upto the top, on the retaining wall is given by

$$P = \frac{wh}{2} \left[ \frac{1 - \sin \phi}{1 + \sin \phi} \right]$$

where  $P$  = Pressure exerted by earth on retaining wall,

$h$  = Height of retaining wall,

$w$  = Weight density of earth retained by the wall,

and  $\phi$  = Angle of repose.

15. Angle of repose is the maximum inclination of a plane at which a body remains in equilibrium over the inclined plane by the assistance of friction only. The earth particles lack in cohesion and have a definite angle of repose.

### EXERCISE 10

#### (A) Theoretical Questions

1. What is the difference between a dam and a retaining wall?
2. Describe the different types of dams. Why a trapezoidal dam is mostly used these days?
3. A masonry dam of rectangular section of height  $H$  and bottom width  $b$  retains water upto a depth of  $h$ . How will you find the point at which the resultant cuts the base. Take the weight density of masonry as  $w_0$ .
4. Prove that the horizontal distance between the line of action of the weight of the dam and the point through the resultant cuts the base of a rectangular dam is given by

$$x = \frac{F}{W} \times \frac{h}{3}$$

where  $F$  = Force exerted by water

$W$  = Weight of dam,

and  $h$  = Depth of water.

5. Prove that the eccentricity in case of a rectangular dam is given by  $e = \frac{F}{W} \times \frac{h}{3}$ .
6. Find an expression for the stresses developed at the base of a rectangular dam which retains water upto a given depth.
7. Prove that the maximum and minimum stresses at the base of a rectangular dam are given by

$$\sigma_{max} = \frac{W}{b} \left( 1 + \frac{6 \cdot e}{b} \right) \quad \text{and} \quad \sigma_{min} = \frac{W}{b} \left( 1 - \frac{6 \cdot e}{b} \right)$$

where  $W$  = Weight of the dam,

$b$  = Width of dam at the base, and

$e$  = Eccentricity.

8. Prove that in case of a trapezoidal dam having water face vertical, the distance between  $A$  and the point through resultant passes at the base is given by

$$d = \frac{a^2 + ab + b^2}{3(a+b)} + \frac{F}{W} \times \frac{h}{3}$$

where  $a$  = Top width of dam,

$b$  = Bottom width of dam,

$F$  = Force exerted by water,

$W$  = Weight of dam, and

$a$  = Depth of water.

9. A trapezoidal dam is having one of the face vertical. If the reservoir is empty, how will you find the stresses at the base of the dam.
10. Find an expression for the stresses induced at the base of a trapezoidal dam having water face inclined.
11. What do you mean by stability of a dam? What are the different conditions under which a dam is going to fail?
12. Prove the statement that the resultant (of the water pressure force and weight of the dam) must lie within middle third of the base width, in order to avoid tension in the masonry of the dam at the base.

13. How will you find the minimum bottom width of a dam, if the dam is safe against sliding, overturning and tensile stress at the base.
14. Define the terms : Retaining wall, dam and angle of repose.
15. A dam of weight  $W$  is placed on an inclined plane, having inclination more than the angle of repose. Prove that the minimum horizontal force applied on the body to keep it in equilibrium when the body is on the point of moving down the plane is given by

$$P = W \tan (\theta - \phi)$$

where  $\theta$  = Angle of inclination of plane and

$\phi$  = Angle of repose.

16. If in the above question, the body is on the point of moving up the plane then prove that minimum horizontal force is given by  $P = W \tan (\theta + \phi)$ .
17. What are the assumptions made in Rankine's theory of earth pressure? How is this theory is used to determine the pressure exerted by the earth on the retaining wall?
18. What do you mean by plane of rupture? Prove that the pressure exerted by the earth on the retaining wall when earth is level upto the top is given by

$$P = \frac{wh^2}{2} \left[ \frac{1 - \sin \phi}{1 + \sin \phi} \right]$$

where  $W$  = Weight density of retained earth by the wall,

$h$  = Height of the retaining wall, and

$\phi$  = Angle of repose.

19. Defined angle of repose.
20. Distinguish between active and passive earth pressure. Draw the active earth pressure diagram against a smooth vertical back retaining wall, and hence explain the intensity of pressure at any depth  $Z$ , the centre of pressure and the total pressure. (AMIE, Summer 1985)

#### (B) Numerical Problems

1. A masonry dam of rectangular section, 16 m high and 8 m wide, has water upto a height of 15 m on its one side. Find :
  - (i) Pressure force due to water on one metre length of the dam,
  - (ii) Position of centre of pressure, and
  - (iii) The point at which the resultant cuts the base. Take density of masonry = 2000 kg/m<sup>3</sup>.  
[Ans. 1103625 N, 5 m, 2.197 m]
2. A masonry dam of rectangular cross-section 12 m high and 5 m wide has water upto the top on its one side. If the density of masonry is 2300 kg/m<sup>3</sup>, find : (i) Pressure force due to water per metre length of dam (ii) Resultant force and the point at which it cuts the base of the dam.  
[Ans. (i) 706320 N (ii) 1.527 MN, 2.087 m]
3. For the question 1, find the maximum and minimum stress intensities at the base of the dam.  
[Ans. 831181.68 and 203341.68 N/m<sup>2</sup>]
4. For the question 2, find the maximum and minimum stress intensities at the base of the dam.  
[Ans. 948833 and 407321 N/m<sup>2</sup>]
5. A trapezoidal masonry dam is of 20 m height. The dam is having water upto a depth of 16 m on its vertical side. The top and bottom width of the dam are 3 m and 9 m respectively. The density of the masonry is given as 2000 kg/m<sup>3</sup>. Determine :
  - (i) the resultant force on the dam per metre length,
  - (ii) the point where the resultant cuts the base, and
  - (iii) the maximum and minimum stress intensities at the base.  
[Ans. 2.1667 MN ; 6.094 m ; 539.6 kN/m<sup>2</sup>, - 16382]

6. A masonry trapezoidal dam 5 m high, 1 m wide at its top and 3 m wide at its bottom remains water on its vertical face. Determine the maximum and minimum stresses at the base :  
 (i) when the reservoir is full and  
 (ii) when the reservoir is empty. Take the density of masonry as  $2000 \text{ kg/m}^3$ .  
 [Ans. (i) 14954, - 1621.33 (ii) 12266 ; 1066.66]
7. A masonry dam of trapezoidal section is 12 m high. It has top width of 1 m and bottom width 6 m. The face exposed to water has a slope of 1 horizontal to 12 vertical. Calculate the maximum and minimum stresses on the base, when the water level coincides with the top of the dam. Take density of masonry, as  $2000 \text{ kg/m}^3$ .  
 [Ans. 228965.4, 65334.6  $\text{N/m}^2$ ]
8. A trapezoidal masonry dam having 4.5 m top width, 9.5 m bottom width and 15 m high, is retaining water upto a height of 12 m. The density of masonry is  $2000 \text{ kg/m}^3$  and co-efficient of friction between the dam and soil is 0.6. The allowable stress is  $392400 \text{ N/m}^2$ . Check the stability of the dam.  
 [Ans. Dam is safe]
9. A trapezoidal masonry dam having top width 2 m and height 10 m, is retaining water upto a height of 9 m. The water face of the dam is vertical. The density of masonry is  $2200 \text{ kg/m}^3$  and co-efficient of friction between the dam and soil is 0.6. Find the minimum bottom width of the dam required.  
 [Ans. 4.46 m]
10. A masonry retaining wall of trapezoidal section is 8 m high and retains earth which is level upto the top. The width at the top is 1.5 m and exposed face is vertical. Find the minimum width of the wall at the bottom in order the tension may not be induced at the base. Masonry and earth has densities  $2300 \text{ kg/m}^3$  and  $1600 \text{ kg/m}^3$  respectively. The angle of repose of the soil is  $30^\circ$ .  
 [Ans. 3.45 m]
11. A masonry retaining wall of trapezoidal section is 12 m high and retains earth which is level upto the top. The width at the top is 3 m and at the bottom 6 m and exposed face is vertical. Find the maximum and minimum intensities of normal stress at the base. Take density of earth =  $1600 \text{ kg/m}^3$  and density of masonry =  $2300 \text{ kg/m}^3$  and angle of repose of earth =  $30^\circ$ .  
 [Ans. 318138.3, 87985.9  $\text{N/m}^2$ ]

## 11

## Analysis of Perfect Frames

## 11.1. INTRODUCTION

A structure made up of several bars (or members) riveted or welded together is known as frame. If the frame is composed of such members which are just sufficient to keep the frame in equilibrium, when the frame is supporting an external load, then the frame is known as *perfect frame*. Though in actual practice the members are welded or riveted together at their joints, yet for calculation purposes the joints are assumed to be hinged or pin-jointed. In this chapter, we shall discuss how to determine the forces in the members of a perfect frame, when it is subject to some external load.

## 11.2. TYPES OF FRAMES

The different types of frames are :

- (i) Perfect frame, and
- (ii) Imperfect frame.

Imperfect frame may be a deficient frame or a redundant frame.

**11.2.1. Perfect Frame.** The frame which is composed of such members, which are just sufficient to keep the frame in equilibrium, when the frame is supporting an external load, is known as perfect frame. The simplest perfect frame is a triangle as shown in Fig. 11.1 which consists three members and three joints. The three members are :  $AB$ ,  $BC$  and  $AC$  whereas the three joints are  $A$ ,  $B$  and  $C$ . This frame can be easily analysed by the condition of equilibrium.

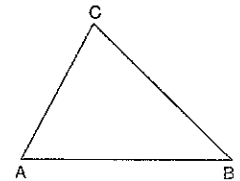

Fig. 11.1

Let the two members  $CD$  and  $BD$  and a joint  $D$  are added to the triangular frame  $ABC$ . Now, we get a frame  $ABCD$  as shown in Fig. 11.2 (a). This frame can also be analysed by the conditions of equilibrium. This frame is also known as perfect frame.

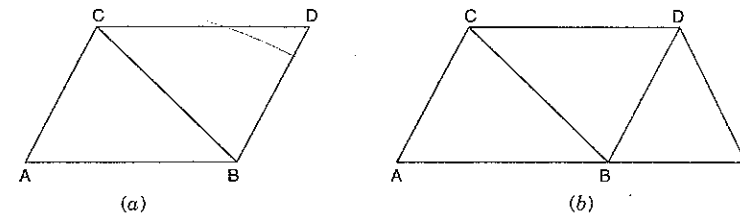

Fig. 11.2



Suppose we add a set of two members and a joint again, we get a perfect frame as shown in Fig. 11.2 (b). Hence for a perfect frame, the number of joints and number of members are given by,

$$n = 2j - 3$$

where  $n$  = Number of members, and  
 $j$  = Number of joints.

**11.2.2. Imperfect Frame.** A frame in which number of members and number of joints are not given by

$$n = 2j - 3$$

is known, an imperfect frame. This means that number of members in an imperfect frame will be either more or less than  $(2j - 3)$ .

(i) If the number of members in a frame are less than  $(2j - 3)$ , then the frame is known as *deficient frame*.

(ii) If the number of members in a frame are more than  $(2j - 3)$ , then the frame is known as *redundant frame*.

**11.3. ASSUMPTIONS MADE IN FINDING OUT THE FORCES IN A FRAME**

The assumptions made in finding out the forces in a frame are :

- (i) The frame is a perfect frame
- (ii) The frame carries load at the joints
- (iii) All the members are pin-jointed.

**11.4. REACTIONS OF SUPPORTS OF A FRAME**

The frames are generally supported

- (i) on roller support or
- (ii) on a hinged support.

If the frame is supported on a roller support, then the line of action of the reaction will be at right angles to the roller base as shown in Figs. 11.3 and 11.4.

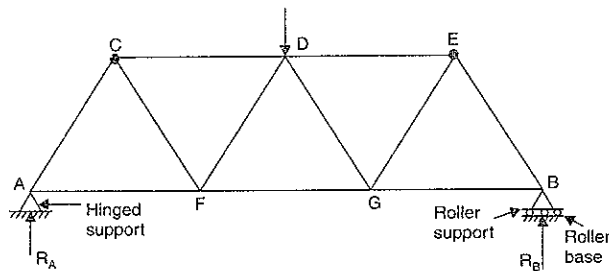

Fig. 11.3

If the frame is supported on a hinged support, then the line of action of the reaction will depend upon the load system on the frame.

The reactions at the supports of a frame are determined by the conditions of equilibrium. The external load on the frame and the reactions at the supports must form a system of equilibrium.

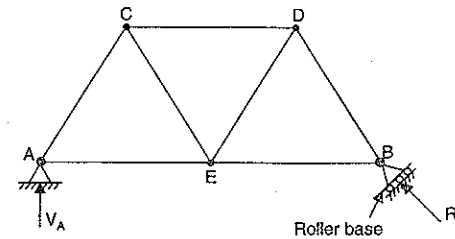

Fig. 11.4

**11.5. ANALYSIS OF A FRAME**

Analysis of a frame consists of :

- (i) Determinations of the reactions at the supports and
- (ii) Determination of the forces in the members of the frame.

The reactions are determined by the condition that the applied load system and the induced reactions at the supports form a system in equilibrium.

The forces in the members of the frame are determined by the condition that every joint should be in equilibrium and so, the forces acting at every joint should form a system in equilibrium.

A frame is analysed by the following methods :

- (i) Method of joints,
- (ii) Method of sections, and
- (iii) Graphical method.

**11.5.1. Method of Joints.** In this method, after determining the reactions at the supports, the equilibrium of every joint is considered. This means the sum of all the vertical forces as well as the horizontal forces acting on a joint is equated to zero. The joint should be selected in such a way that at any time there are only two members, in which the forces are unknown. The force in the member will be compressive if the member *pushes the joint* to which it is connected whereas the force in the member will be tensile if the member *pulls the joint* to which it is connected.

**Problem 11.1.** Find the forces in the members AB, AC and BC of the truss shown in Fig. 11.5.

**Sol.** First determine the reactions  $R_B$  and  $R_C$ . The line of action of load of 20 kN acting at A is vertical. This load is at a distance of  $AB \times \cos 60^\circ$  from the point B. Now let us find the distance AB.

The triangle ABC is a right-angled triangle with angle  $BAC = 90^\circ$ . Hence AB will be equal to  $BC \times \cos 60^\circ$ .

$$\therefore AB = 5 \times \cos 60^\circ = 5 \times \frac{1}{2} = 2.5 \text{ m}$$

Now the distance of line of action of 20 kN from B is

$$AB \times \cos 60^\circ \text{ or } 2.5 \times \frac{1}{2} = 1.25 \text{ m.}$$

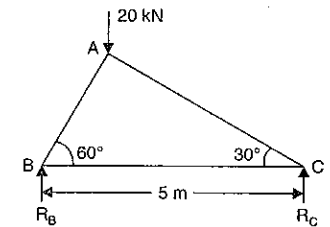

Fig. 11.5

Taking the moments about B, we get

$$R_C \times 5 = 20 \times 1.25 = 25$$

$$R_C = \frac{25}{5} = 5 \text{ kN}$$

$$R_B = \text{Total load} - R_C = 20 - 5 = 15 \text{ kN}$$

Now let us consider the equilibrium of the various joints.

#### Joint B

Let  $F_1$  = Force in member AB

$F_2$  = Force in member BC

Let the force  $F_1$  is acting towards the joint B and the force  $F_2$  is acting away\* from the joint B as shown in Fig. 11.6. (The reaction  $R_B$  is acting vertically up. The force  $F_2$  is horizontal. The reaction  $R_B$  will be balanced by the vertical component of  $F_1$ . The vertical component of  $F_1$  must act downwards to balance  $R_B$ . Hence  $F_1$  must act towards the joint B so that its vertical component is downward. Now the horizontal component of  $F_1$  is towards the joint B. Hence force  $F_2$  must act away from the joint to balance the horizontal component of  $F_1$ ).

Resolving the forces acting on the joint B, vertically

$$F_1 \sin 60^\circ = 15$$

$$F_1 = \frac{15}{\sin 60^\circ} = \frac{15}{0.866} = 17.32 \text{ kN (Compressive)}$$

As  $F_1$  is pushing the joint B, hence this force will be compressive. Now resolving the forces horizontally, we get

$$F_2 = F_1 \cos 60^\circ = 17.32 \times \frac{1}{2} = 8.66 \text{ kN (tensile)}$$

As  $F_2$  is pulling the joint B, hence this force will be tensile.

#### Joint C

Let  $F_3$  = Force in the member AC

$F_2$  = Force in the member BC

The force  $F_2$  has already been calculated in magnitude and direction. We have seen that force  $F_2$  is tensile and hence it will pull the joint C. Hence it must act away from the joint C as shown in Fig. 11.7.

Resolving forces vertically, we get

$$F_3 \sin 30^\circ = 5 \text{ kN}$$

$$F_3 = \frac{5}{\sin 30^\circ} = 10 \text{ kN (Compressive)}$$

As the force  $F_3$  is pushing the joint C, hence it will be compressive. **Ans.**

**Problem 11.2.** A truss of span 7.5 m carries a point load of 1 kN at joint D as shown in Fig. 11.8. Find the reactions and forces in the members of the truss.

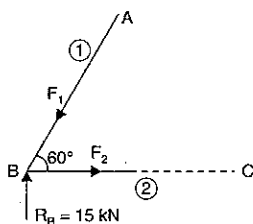

Fig. 11.6

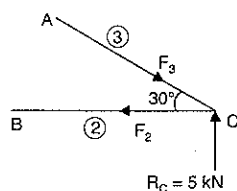

Fig. 11.7

**Sol.** Let us first determine the reactions  $R_A$  and  $R_B$

Taking moments about A, we get  $R_B \times 7.5 = 5 \times 1$

$$R_B = \frac{5}{7.5} = \frac{2}{3} = 0.667 \text{ kN}$$

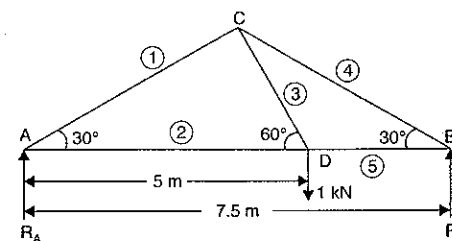

Fig. 11.8

$$R_A = \text{Total load} - R_B = 1 - 0.667 = 0.333 \text{ kN}$$

Now consider the equilibrium of the various joints.

#### Joint A

Let  $F_1$  = Force in member AC

$F_2$  = Force in member AD.

Let the force  $F_1$  is acting towards the joint A and  $F_2$  is acting away from the joint A as shown in Fig. 11.9.

Resolving the forces vertically, we get

$$F_1 \sin 30^\circ = R_A$$

$$F_1 = \frac{R_A}{\sin 30^\circ} = \frac{0.333}{0.5} = 0.666 \text{ kN (Compressive)}$$

Resolving the forces horizontally, we get

$$F_2 = F_1 \times \cos 30^\circ = 0.666 \times 0.866 = 0.5767 \text{ kN (Tensile)}$$

#### Joint B

Let  $F_4$  = Force in member BC

$F_5$  = Force in member BD

Let the direction of  $F_4$  and  $F_5$  are assumed as shown in Fig. 11.10.

Resolving the forces vertically, we get

$$F_4 \sin 30^\circ = R_B = 0.667$$

$$F_4 = \frac{0.667}{\sin 30^\circ} = 1.334 \text{ kN (Compressive)}$$

Resolving the forces horizontally, we get

$$F_5 = F_4 \cos 30^\circ = 1.334 \times 0.866 = 1.155 \text{ kN (Tensile)}$$

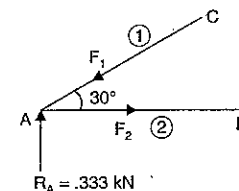

Fig. 11.9

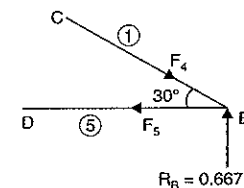

Fig. 11.10

\*The direction of  $F_2$  can also be taken towards the joint B. Actually when we consider the equilibrium of the joint B, if the magnitude of  $F_1$  and  $F_2$  comes out to be positive then the assumed direction of  $F_1$  and  $F_2$  are correct. But if any one of them is having a negative magnitude then the assumed direction of that force is wrong. Correct direction then will be the reverse of the assumed direction.

**Joint D**

Let  $F_3$  = Force in member  $CD$ . The forces  $F_2$  and  $F_5$  have been already calculated in magnitude and direction. The forces  $F_2$  and  $F_5$  are tensile and hence they will be pulling the joint  $D$  as shown in Fig. 11.11. Let the direction\* of  $F_3$  is assumed as shown in Fig. 11.11.

Resolving the forces vertically, we get

$$F_3 \sin 60^\circ = 1$$

$$\therefore F_3 = \frac{1}{\sin 60^\circ} = \frac{1}{0.866} = 1.1547 \text{ kN (Tensile)}$$

Hence the forces in the members are:

$$F_1 = 0.666 \text{ kN (Compressive)}$$

$$F_2 = 0.5767 \text{ kN (Tensile)}$$

$$F_3 = 1.1547 \text{ kN (Tensile)}$$

$$F_4 = 1.334 \text{ kN (Compressive)}$$

$$F_5 = 1.155 \text{ kN (Tensile). Ans.}$$

**Problem 11.3.** A truss of span 5 m is loaded as shown in Fig. 11.12. Find the reactions and forces in the members of the truss.

**Sol.** Let us first determine the reactions  $R_A$  and  $R_B$ .

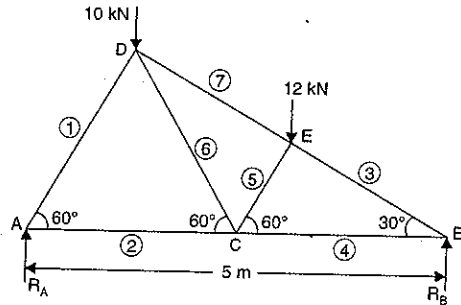

Fig. 11.12

Triangle  $ABD$  is a right-angled triangle having angle  $ADB = 90^\circ$ .

$$\therefore AD = AB \cos 60^\circ = 5 \times 0.5 = 2.5 \text{ m}$$

The distance of the line of action of the vertical load 10 kN from point  $A$  will be  $AD \cos 60^\circ$

$$\text{or } 2.5 \times 0.5 = 1.25 \text{ m.}$$

From triangle  $ACD$ , we have  $AC = AD = 2.5 \text{ m}$

$$\therefore BC = 5 - 2.5 = 2.5 \text{ m}$$

In right-angled triangle  $CEB$ , we have

$$BE = BC \cos 30^\circ = 2.5 \times \frac{\sqrt{3}}{2}$$

\*The horizontal force  $F_5$  is more than  $F_2$ . Hence the horizontal component of  $F_3$  must be in the direction of  $F_2$ . This is only possible if  $F_3$  is acting away from  $D$ .

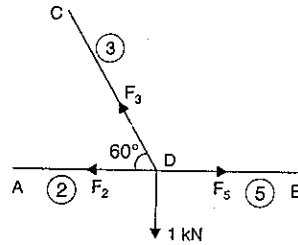

Fig. 11.11

The distance of the line of action of the vertical load of 12 kN from point  $B$  will be  $BE \times \cos 30^\circ$

$$\text{or } BE \times \frac{\sqrt{3}}{2} = \left(2.5 \times \frac{\sqrt{3}}{2}\right) \times \frac{\sqrt{3}}{2} = 1.875 \text{ m.}$$

$\therefore$  The distance of the line of action of the load of 12 kN from point  $A$  will be  $(5 - 1.875) = 3.125 \text{ m.}$

Now taking the moments about  $A$ , we get

$$R_B \times 5 = 10 \times 1.25 + 12 \times 3.125 = 50$$

$$\therefore R_B = \frac{50}{5} = 10 \text{ kN}$$

$$\therefore R_A = \text{Total load} - R_B = (10 + 12) - 10 = 12 \text{ kN}$$

Now consider the equilibrium of the various joints.

**Joint A**

Let  $F_1$  = Force in member  $AD$ , and

$F_2$  = Force in member  $AC$

Let the directions of  $F_1$  and  $F_2$  are assumed as shown in

Fig. 11.13.

Resolving the forces vertically,

$$F_1 \sin 60^\circ = 12$$

$$\therefore F_1 = \frac{12}{\sin 60^\circ} = 13.856 \text{ kN (Compressive)}$$

Resolving the forces horizontally,

$$F_2 = F_1 \cos 60^\circ = 13.856 \times 0.5 = 6.928 \text{ kN (Tensile)}$$

Now consider the joint  $B$ .

**Joint B**

Let  $F_3$  = Force in member  $BE$ , and

$F_4$  = Force in member  $BC$

Let the directions of  $F_3$  and  $F_4$  are assumed as shown in Fig.

11.14.

Resolving the forces vertically, we get

$$F_3 \sin 30^\circ = 10$$

$$\therefore F_3 = \frac{10}{\sin 30^\circ} = 20 \text{ kN (Compressive)}$$

Now resolving the forces horizontally, we get

$$F_4 = F_3 \cos 30^\circ = 20 \times 0.866 = 17.32 \text{ kN (Tensile)}$$

Now consider the joint  $C$ .

**Joint C**

Let  $F_5$  = Force in member  $CE$

$F_6$  = Force in member  $CD$

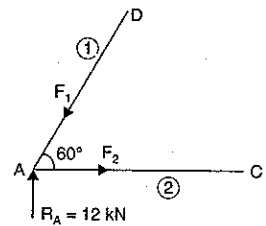

Fig. 11.13

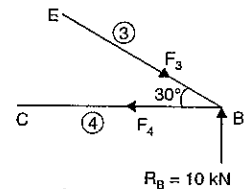

Fig. 11.14

Let the directions of  $F_5$  and  $F_6$  are assumed as shown in Fig. 11.15.

The forces  $F_2$  and  $F_4$  are already known in magnitude and directions. They are tensile and hence will be pulling the joint C as shown in Fig. 11.15.

Resolving forces vertically, we get

$$F_6 \sin 60^\circ + F_5 \sin 60^\circ = 0$$

or  $F_6 = -F_5$  ... (i)

Resolving forces horizontally, we get

$$F_2 - F_6 \cos 60^\circ = F_4 - F_5 \cos 60^\circ$$

or  $6.928 - \frac{F_6}{2} = 17.32 - \frac{F_5}{2}$

or  $\frac{-F_6 + F_5}{2} = 17.32 - 6.928 = 10.392$

or  $-F_6 + F_5 = 10.392 \times 2 = 20.784$

or  $F_5 + F_5 = 20.784$

$$(\because -F_6 = F_5)$$

$$\therefore F_5 = \frac{20.784}{2} = 10.392 \text{ kN}$$

and  $F_6 = -F_5 = -10.392 \text{ kN}$

The magnitude of  $F_6$  is -ve, hence the assumed direction of  $F_6$  is wrong. The correct direction  $F_6$  will be as shown in Fig. 11.15 (a).

$$\therefore F_5 = 10.392 \text{ (Compressive)}$$

$$\text{and } F_6 = 10.392 \text{ (Tensile)}$$

Now consider the joint E.

**Joint E**

Let  $F_7$  = Force in member ED

Let  $F_7$  is acting as shown in Fig. 11.16.

The forces  $F_3$  and  $F_5$  are known in magnitude and directions. They are compressive hence they will be pushing the joint E as shown in Fig. 11.16.

Resolving the forces along BED, we get

$$F_7 + 12 \cos 60^\circ = F_3$$

$$F_7 = F_3 - 12 \times 0.5$$

$$= 20 - 6 = 14 \text{ kN}$$

(Compressive)

As  $F_7$  is positive hence the assumed direction of  $F_7$  is correct. **Ans.**

**Problem 11.4.** A truss of span 9 m is loaded as shown in Fig. 11.17. Find the reactions and forces in the member of the truss.

**Sol.** Let us first calculate the reactions  $R_A$  and  $R_B$ .

Taking moments about A, we get

$$R_B \times 9 = 9 \times 3 + 12 \times 6 = 27 + 72 = 99$$

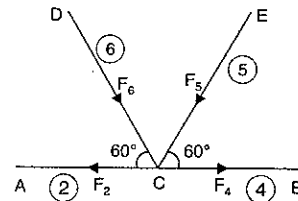

Fig. 11.15

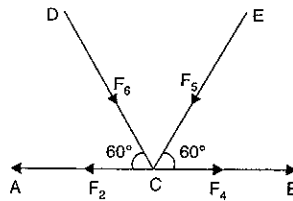

Fig. 11.15 (a)

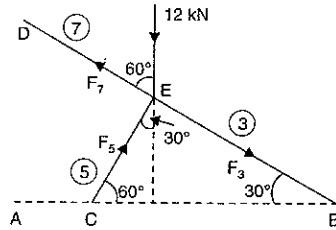

Fig. 11.16

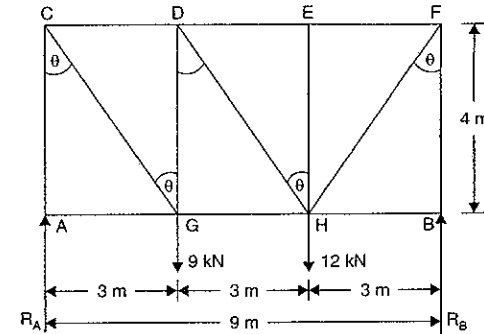

Fig. 11.17

$$\therefore R_B = \frac{99}{9} = 11 \text{ kN}$$

and

$$R_A = \text{Total load} - R_B = (9 + 12) - 11 = 10 \text{ kN}$$

In this problem, there are some members in which force is zero.

These members are obtained directly as given below :

“If three forces act at a joint and two of them are along the same straight line, then for the equilibrium of the joint, the third force should be equal to zero.”

1. Three forces are acting at the point A (i.e.,  $R_A$ ,  $F_{AC}$  and  $F_{AG}$ ), two of which (i.e.,  $R_A$ ,  $F_{AC}$ ) are along the same straight line. Hence the third force (i.e.,  $F_{AG}$ ) is zero.

2. Similarly, three forces are acting at the joint B (i.e.,  $R_B$ ,  $F_{BF}$  and  $F_{BH}$ ), two of which (i.e.,  $R_B$  and  $F_{BF}$ ) are along the same straight line. Hence the third force  $F_{BH}$  should be zero.

3. At the joint E also, three forces (i.e.,  $F_{ED}$ ,  $F_{EF}$  and  $F_{EH}$ ) are acting, two of which (i.e.,  $F_{ED}$  and  $F_{EF}$ ) are along the same straight line. Hence the third force  $F_{EH}$  must be zero.

Now the equilibrium of various joints can be considered.

**Joint A** [See Fig. 11.17 (a)]

$$F_{AG} = \text{Force in member AG} = 0$$

$$F_{AC} = \text{Force in member AC} = R_A = 10 \text{ kN (Compressive)}$$

Now consider the equilibrium of joint C.

**Joint C** [See Fig. 11.17 (b)]

Let  $F_{CD}$  = Force in member CD

$$F_{CG} = \text{Force in member CG}$$

$$F_{AC} = 10 \text{ kN (Compressive)}$$

Let the directions of  $F_{CG}$  and  $F_{CD}$  are assumed as shown in Fig. 11.17 (b).

Resolving the forces vertically, we get

$$F_{CG} \cos \theta = 10$$

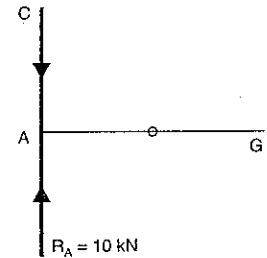

Fig. 11.17 (a)

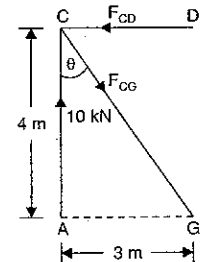

Fig. 11.17 (b)

$$\therefore F_{CG} = \frac{10}{\cos \theta}$$

But  $\cos \theta = \frac{AG}{CG} = \frac{4}{5} \quad (\because CG = \sqrt{3^2 + 4^2} = 5)$

$$\therefore F_{CG} = \frac{10}{(4/5)} = 10 \times \frac{5}{4} = 12.5 \text{ kN (Tensile)}$$

Resolving forces horizontally, we get

$$F_{CD} = F_{CG} \sin \theta = 12.5 \times \frac{3}{5} = 7.5 \text{ kN (Compressive)}$$

Now consider the equilibrium of joint G.

**Joint G**

The force in member CG is 12.5 kN (Tensile).

Hence at the joint G, this force will be pulling the joint G as shown in Fig. 11.17 (c).

Resolving the forces vertically, we get

$$12.5 \cos \theta + F_{GD} = 9$$

$$\therefore F_{GD} = 9 - 12.5 \cos \theta = 9 - 12.5 \times \frac{4}{5} \quad (\because \sin \theta = \frac{4}{5})$$

$$= 9 - 10 = -1 \text{ kN.}$$

As the magnitude of  $F_{GD}$  is negative, hence its assumed direction is wrong. The correct direction will be as shown in Fig. 11.17 (d).

Then,  $F_{GD} = 1 \text{ kN (Compressive)}$

Resolving the forces horizontally, we get

$$12.5 \sin \theta = F_{GH}$$

$$F_{GH} = 12.5 \times \frac{3}{5} \quad (\because \cos \theta = \frac{3}{5})$$

$$= 7.5 \text{ kN (Tensile)}$$

or

Now consider the equilibrium of joint D.

**Joint D**

The forces in the members CD and GD have been already calculated. They are 7.5 kN and 1 kN respectively. Both are compressive.

Let  $F_{DH}$  = Force in member DH, and

$F_{DE}$  = Force in member DE

Resolving the forces vertically, we get

$$F_{DH} \cos \theta = 1 \text{ kN}$$

$$\therefore F_{DH} = \frac{1}{\cos \theta} = \frac{1}{(4/5)} = \frac{5}{4} = 1.25 \text{ kN (Tensile)}$$

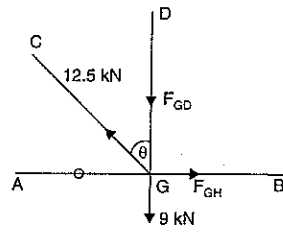

Fig. 11.17 (c)

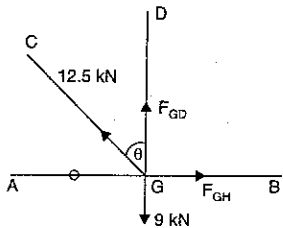

Fig. 11.17 (d)

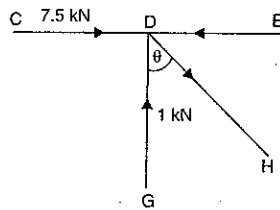

Fig. 11.17 (e)

Resolving the forces horizontally, we get

$$7.5 + F_{DH} \sin \theta = F_{DE}$$

or

$$F_{DE} = 7.5 + 1.25 \times \frac{3}{5} \quad (\because \sin \theta = \frac{3}{5})$$

$$= 7.5 + 0.75 = 8.25 \text{ kN (Compressive)}$$

Now consider the equilibrium of joint E.

**Joint E**

As shown in Fig. 11.17 (f), at joint E three forces are acting. The forces i.e.,  $F_{DE}$  and  $F_{EF}$  are in the same straight line.

Hence force  $F_{EH}$  must be zero.

Force in EF, i.e.,  $F_{EF} = F_{DE} = 8.25 \text{ kN (Compressive)}$

Now consider the joint H.

**Joint H**

It is already shown that forces in the members EH and BH are zero.

Also the forces in the member GH is 7.5 kN tensile and in the member DH is 1.25 kN tensile.

Let  $F_{HF}$  is the force in the member HF.

Resolving forces vertically, we get

$$1.25 \cos \theta + F_{HF} \cos \theta = 12$$

$$\text{or } 1.25 \times \frac{4}{5} + F_{HF} \times \frac{4}{5} = 12 \quad (\because \cos \theta = \frac{4}{5})$$

$$1.0 + 0.8 F_{HF} = 12$$

$$\text{or } F_{HF} = \frac{12 - 1.0}{0.8} = \frac{11}{0.8} = 13.75$$

Now consider the joint B.

**Joint B**

See Fig. 11.17 (h).

The force in member BF

$$= 11 \text{ kN (Compressive)}$$

Now the forces in each member are known.

They are shown in Fig. 11.18. Also these forces are shown in a tabular form.

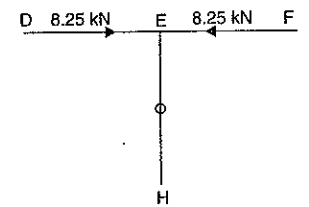

Fig. 11.17 (f)

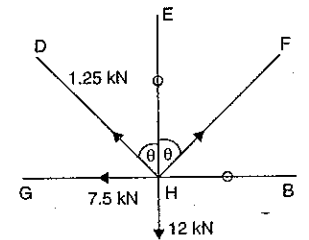

Fig. 11.17 (g)

(Tensile)

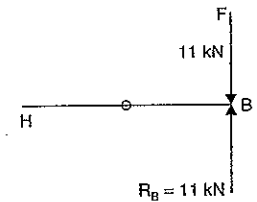

Fig. 11.17 (h)

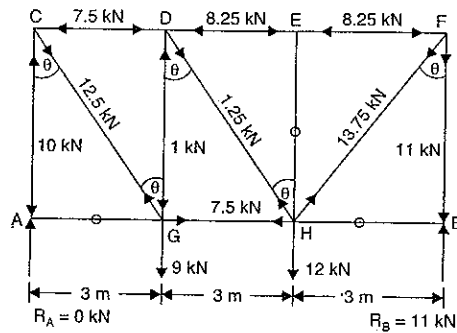

Fig. 11.18

Member	Force in member
AC	10 kN (Comp.)
AG	0
CG	12.5 kN (Tens.)
CD	7.5 kN (Comp.)
DG	10 kN (Comp.)
DE	8.25 kN (Comp.)
DH	1.25 kN (Tens.)
GH	7.5 kN (Tens.)
EH	0
EF	8.25 kN (Comp.)
HB	0
HF	13.75 kN (Tens.)
BF	11 kN (Comp.)

**Problem 11.5.** A plane truss is loaded and supported as shown in Fig. 11.19. Determine the nature and magnitude of the forces in the members 1, 2 and 3.

**Sol.** First calculate the reactions  $R_A$  and  $R_B$

Taking moments about A, we get

$$R_B \times 4 = 1 \times 1000$$

$$\therefore R_B = \frac{1000}{4} = 250 \text{ N}$$

$$\therefore R_A = 1000 - 250 = 750 \text{ N}$$

From figure, we know that

$$\tan \theta = \frac{CH}{AH} = \frac{2.25}{4} = 0.75$$

$$\cos \theta = \frac{AH}{CH} = \frac{3}{3.75} = 0.8$$

$$\sin \theta = \frac{CH}{AC} = \frac{2.25}{3.75} = 0.6$$

$$\left( \because AC = \sqrt{3^2 + 2.25^2} = 3.75 \right)$$

and

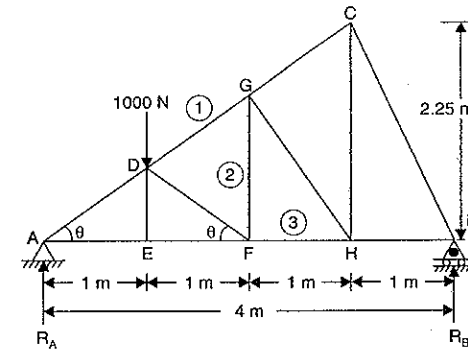

Fig. 11.19

Consider the equilibrium of joint A.

**Joint A** [See Fig. 11.19 (a)]

Resolving the forces vertically,

$$F_{AD} \sin \theta = 750$$

$$\therefore F_{AD} = \frac{750}{\sin \theta} = \frac{750}{0.6} = 1250 \text{ N (Compressive)}$$

Resolving the forces horizontally, we get

$$F_{AE} = F_{AD} \cos \theta = 1250 \times 0.8 = 1000 \text{ N (Tensile)}$$

Now consider joint E.

**Joint E**

Three forces, i.e.,  $F_{AE}$ ,  $F_{EF}$  and  $F_{ED}$  are acting at the joint E. Two of the forces, i.e.,  $F_{AE}$  and  $F_{EF}$  are in the same straight line. Hence the third force, i.e.,  $F_{ED}$  should be zero and

$$F_{EF} = F_{AE} = 1000 \text{ N (Tensile)}$$

Now consider the equilibrium of joint D.

**Joint D**

Let  $F_1$  = Force in member DG

$F_{DF}$  = Force in member DF.

Let us assume their directions as shown in Fig. 11.19 (b).

The forces in the member AD and DE are 1250 N (Compressive) and 0 respectively.

Resolving forces vertically, we get

$$1250 \sin \theta + F_1 \sin \theta + F_{DF} \sin \theta = 1000$$

$$\text{or } 1250 \times 0.6 + F_1 \times 0.6 + F_{DF} \times 0.6 = 1000$$

$$\left( \because \sin \theta = 0.6 \right)$$

$$\text{or } 1250 + F_1 + F_{DF} = \frac{1000}{0.6} = 1666.66$$

$$\text{or } F_1 + F_{DF} = 1666.66 - 1250 = 416.66 \quad \dots(i)$$

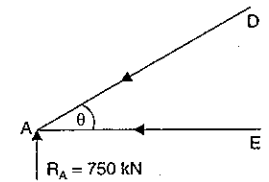

Fig. 11.19 (a)

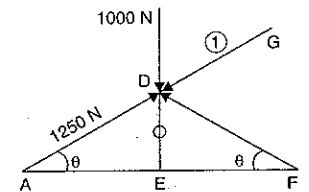

Fig. 11.19 (b)

Resolving the forces horizontally, we get

$$1250 \cos \theta + F_1 \cos \theta = F_{DF} \times \cos \theta$$

or  $1250 + F_1 = F_{DF}$  or  $F_1 - F_{DF} = -1250$  ... (ii)

Adding (i) and (ii), we get

$$2F_1 = 416.66 - 1250 = -833.34$$

$$F_1 = -\frac{833.34}{2} = -416.67 \text{ N}$$

Substituting the value of  $F_1$  in equation (i), we get

$$-416.67 + F_{DF} = 416.66$$

or  $F_{DF} = 416.66 + 416.67 = 833.33 \text{ N (Comp.)}$

The magnitude of  $F_1$  is negative. Hence its assumed direction is wrong. The correct direction of  $F_1$  is shown in Fig. 11.19 (c).

$$F_1 = 416.67 \text{ N (Compressive). Ans.}$$

To find the forces  $F_2$  and  $F_3$ , consider the joint F.

**Joint F**

The forces in the members DF and EF are already known. They are :

$$F_{DF} = 833.33 \text{ N (Compressive)}$$

$$F_{EF} = 1000 \text{ N (Tensile)}$$

These forces are acting at the joint F as shown in Fig. 11.19 (d).

Let  $F_2 =$  Force in member FG, and

$F_3 =$  Force in member FH

Resolving forces vertically, we get

$$833.33 \sin \theta = F_2$$

or  $F_2 = 833.33 \times 0.6 = 499.998 \text{ N} \approx 500 \text{ N (Tensile). Ans.}$  ( $\because \sin \theta = 0.6$ )

Resolving forces horizontally, we get

$$F_3 + 833.33 \cos \theta = 1000$$

or  $F_3 = 1000 - 833.33 \times 0.8 = 333.336 \text{ N (Tensile). Ans.}$  ( $\because \cos \theta = 0.8$ )

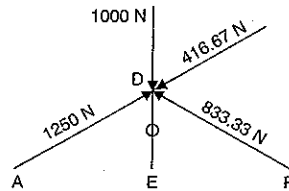

Fig. 11.19 (c)

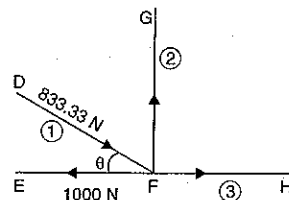

Fig. 11.19 (d)

**11.5.2. Method of Joints Applied to Cantilever Trusses.** In case of cantilever trusses, it is not necessary to determine the support reactions. The forces in the members of cantilever truss can be obtained by starting the calculations from the free end of the cantilever.

**Problem 11.6.** Determine the forces in all the members of a cantilever truss shown in Fig. 11.20.

**Sol.** Here the calculations can be started from end C. Hence consider the equilibrium of the joint C.

**Joint C**

Let  $F_{CD} =$  Force in member CD, and

$F_{CA} =$  Force in member CA.

Their assumed directions are shown in Fig. 11.20.

Resolving the force vertically, we get

$$F_{CD} \times \sin 60^\circ = 1000$$

$$\therefore F_{CD} = \frac{1000}{\sin 60^\circ} = \frac{1000}{0.866} = 1154.7 \text{ N (Tensile)}$$

Resolving the forces horizontally, we get

$$F_{CA} = F_{CD} \times \cos 60^\circ = 1154.7 \times 0.5 = 577.35 \text{ N (Compressive)}$$

Now consider the equilibrium of the joint D.

**Joint D**

[See Fig. 11.20 (a)]

The force  $F_{CD} = 1154.7 \text{ N}$  (tensile) is already calculated.

Let  $F_{AD} =$  Force in member AD, and

$F_{BD} =$  Force in member BD

Their assumed directions are shown in Fig. 11.20 (a).

Resolving the forces vertically, we get

$$F_{AD} \cos 30^\circ = 1154.7 \cos 30^\circ$$

$$\therefore F_{AD} = \frac{1154.7 \cos 30^\circ}{\cos 30^\circ} = 1154.7 \text{ N}$$

(Compressive)

Resolving the forces horizontally, we get

$$F_{BD} = F_{AD} \sin 30^\circ + F_{DC} \sin 30^\circ = 1154.7 \times 0.5 + 1154.7 \times 0.5 = 1154.7 \text{ N (Tensile)}$$

Now the forces are shown in a tabular form below :

Member	Force in the member	Nature of force
AC	577.35 N	Compressive
CD	1154.7 N	Tensile
AD	1154.7 N	Compressive
BD	1154.7 N	Tensile

**Problem 11.7.** Determine the forces in all the members of a cantilever truss shown in Fig. 11.21.

**Sol.** Start the calculations from joint C.

From triangle ACE, we have

$$\tan \theta = \frac{AS}{AC} = \frac{3}{4}$$

Also  $EC = \sqrt{3^2 + 4^2} = 5$

$$\therefore \cos \theta = \frac{AC}{CE} = \frac{4}{5} = 0.8$$

$$\sin \theta = \frac{AE}{CE} = \frac{3}{5} = 0.6$$

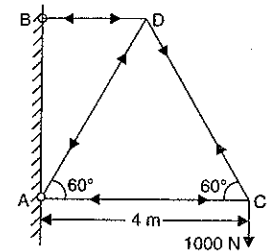

Fig. 11.20

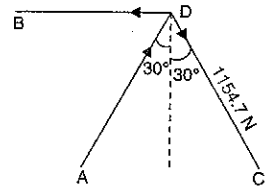

Fig. 11.20 (a)

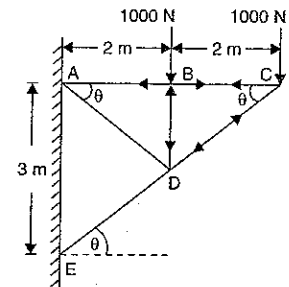

Fig. 11.21

**Joint C**

The direction of forces at the joint C are shown in Fig. 11.21.

Resolving the forces vertically, we get

$$F_{CD} \sin \theta = 1000$$

$$\therefore F_{CD} = \frac{1000}{\sin \theta} = \frac{1000}{0.6} = 1666.66 \text{ N (Compressive)}$$

Resolving the forces horizontally, we get

$$F_{CB} = F_{CD} \times \cos \theta = 1666.66 \times 0.8 = 1333.33 \text{ N (Tensile)}$$

Now consider the equilibrium of joint B.

**Joint B**

Resolving vertically, we get

$$F_{BD} = 1000 \text{ N (Compressive)}$$

$$F_{BA} = F_{CB} = 1333.33 \text{ (Tensile)}$$

Now consider the joint D.

**Joint D**

The forces in member CD and BD have already been calculated. They are 1666.66 N and 1000 N respectively as shown in Fig. 11.21 (a).

Let  $F_{DA}$  = Force in member DA, and

$F_{DE}$  = Force in member DE

Resolving forces vertically, we get

$$1000 + 1666.66 \sin \theta = F_{AD} \sin \theta + F_{ED} \sin \theta$$

$$1000 + 1666.66 \times 0.6 = F_{AD} \times 0.6 + F_{ED} \times 0.6$$

$$\text{or } F_{AD} + F_{ED} = \frac{1000}{0.6} + 1666.66 = 3333.32 \dots(i)$$

Resolving forces horizontally, we get

$$1666.66 \cos \theta + F_{AD} \cos \theta = F_{ED} \cos \theta$$

$$1666.66 + F_{AD} = F_{ED} \text{ or } F_{ED} - F_{AD} = 1666.66 \dots(ii)$$

Adding equations (i) and (ii), we get

$$2F_{ED} = 3333.32 + 1666.66 = 4999.98$$

$$\therefore F_{ED} = \frac{4999.98}{2} = 2499.99 \approx 2500 \text{ N (Compressive)}$$

Substituting this value in equation (i), we get

$$F_{AD} + 2500 = 3333.32$$

$$\therefore F_{AD} = 3333.32 - 2500 = 833.32 \text{ N (Tensile)}$$

Now the forces are shown in a tabular form below :

Member	Force in the member	Nature of force
AB	1333.33 N	Tensile
BC	1333.33 N	Tensile
CD	1666.66 N	Compressive
DE	2500 N	Compressive
AD	833.32 N	Tensile
BD	1000 N	Compressive

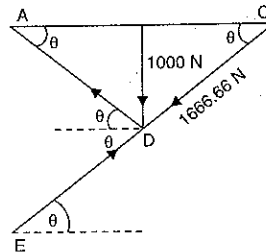

Fig. 11.21 (a)

**11.5.3. Method of Joints Applied to Trusses Carrying Horizontal Loads.** If a truss carries horizontal loads (with or without vertical loads), hinged at one end and supported on rollers at the other end, then the support reaction at the roller supported end will be normal, whereas the support reactions at the hinged end will consists of : (i) horizontal reaction and (ii) vertical reaction.

The horizontal reaction will be obtained by adding algebraically all the horizontal loads ; whereas the vertical reaction will be obtained by subtracting the roller support reaction from the total vertical loads. Now the forces in the members of the truss can be determined.

**Problem 11.8.** Determine the forces in the truss shown in Fig. 11.22 which carries a horizontal load of 12 kN and a vertical load of 18 kN.

**Sol.** The truss is supported on rollers at B and hence the reaction at B must be normal to the roller base i.e., the reaction at B, in this case, should be vertical.

At the end A, the truss is hinged and hence the support reactions at the hinged end A will consists of a horizontal reaction  $H_A$  and a vertical reaction  $R_A$ .

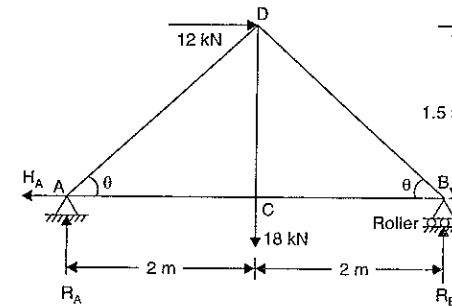

Fig. 11.22

Taking moments of all forces at A, we get

$$R_B \times 4 = 18 \times 2 + 12 \times 1.5 = 36 + 18 = 54$$

$$\therefore R_B = \frac{54}{4} = 13.5 \text{ kN } (\uparrow)$$

$$\therefore R_A = \text{Total vertical load} - R_B = 18 - 13.5 = 4.5 \text{ kN } (\uparrow)$$

and  $H_A = \text{Sum of all horizontal loads} = 12 \text{ kN } (\leftarrow)$

Now the forces in the members can be calculated.

In triangle BCD,  $BD = \sqrt{BC^2 + CD^2} = \sqrt{2^2 + 1.5^2} = 2.5 \text{ m}$

$$\therefore \cos \theta = \frac{BC}{BD} = \frac{2}{2.5} = 0.8$$

$$\sin \theta = \frac{CD}{BD} = \frac{1.5}{2.5} = 0.6$$

Let us first consider the equilibrium of joint A.



**Joint A**

The reactions  $R_A$  and  $H_A$  are known in magnitude and direction. Let the directions of the forces in the members AC and AD are as shown in Fig. 11.22 (a).

Resolving the forces vertically, we get

$$F_{AD} \sin \theta = R_A$$

or 
$$F_{AD} = \frac{R_A}{\sin \theta} = \frac{4.5}{0.6} = 7.5 \text{ kN (Compressive)}$$

Resolving the forces horizontally, we get

$$F_{AC} = H_A + F_{AD} \cos \theta = 12 + 7.5 \times 0.8 = 18 \text{ kN (Tensile)}$$

Now consider the joint C.

**Joint C**

At the joint C, the force  $O$  in member CA and vertical load 18 kN are known in magnitude and directions. For equilibrium of the joint C.

$$F_{BC} = F_{CA} = 18 \text{ kN (Tensile)}$$

$$F_{CD} = 18 \text{ kN (Tensile)}$$

Now consider the joint B.

**Joint B**

At the joint B,  $R_B$  and force  $F_{BC}$  are known in magnitude and direction.

Let  $F_{BD}$  is the force in member BD.

Resolving the forces vertically, we get

$$F_{BD} \times \sin \theta = R_B$$

$$\therefore F_{BD} = \frac{R_B}{\sin \theta} = \frac{13.5}{0.6} = 22.5 \text{ kN (Compressive)}$$

Now the forces are shown in a tabular form below :

Member	Force in the member	Nature of force
AC	18 kN	Tensile
AD	7.5 kN	Compressive
CD	18 kN	Tensile
CB	18 kN	Tensile
BD	2.5 kN	Compressive

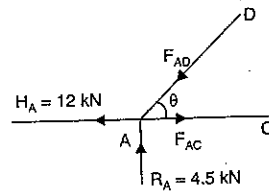

Fig. 11.22 (a)

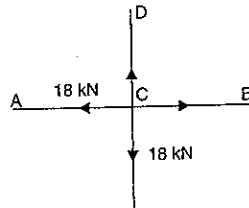

Fig. 11.22 (b)

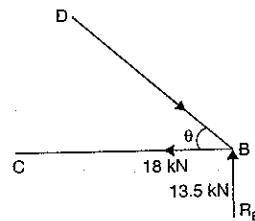

Fig. 11.22 (c)

**Problem 11.9.** Determine the forces in the truss shown in Fig. 11.23 which is subjected to horizontal and vertical loads. Mention the nature of forces in each case.

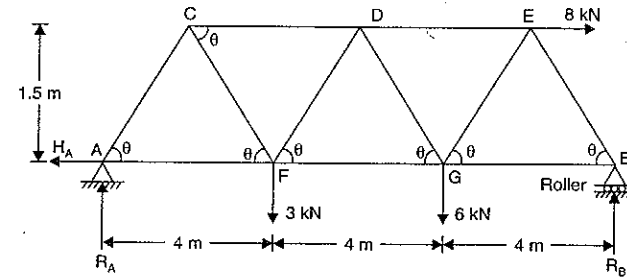

Fig. 11.23

**Sol.** The truss is supported on rollers at B and hence  $R_B$  will be vertical. The truss is hinged at A and hence the support reactions at A will consist of a horizontal reaction  $H_A$  and a vertical reaction  $R_A$ .

Taking moment about A, we get

$$R_B \times 12 = 8 \times 1.5 + 3 \times 4 + 6 \times 8 = 72$$

$$\therefore R_B = \frac{72}{12} = 6 \text{ kN } (\uparrow)$$

and

$$R_A = \text{Total vertical loads} - R_B = (3 + 6) - 6 = 3 \text{ kN } (\uparrow)$$

and

$$H_A = \text{Sum of all horizontal loads} = 8 \text{ kN } (\leftarrow)$$

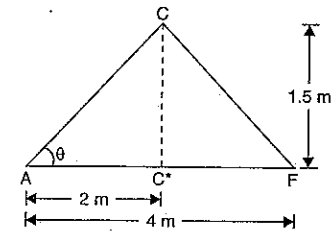

Fig. 11.23 (a)

In the triangle ACC\*,  $AC = \sqrt{AC^*2 + CC^*2} = \sqrt{2^2 + 1.5^2} = 2.5$

$$\therefore \cos \theta = \frac{AC^*}{AC} = \frac{2}{2.5} = 0.8 \text{ and } \sin \theta = \frac{CC^*}{AC} = \frac{1.5}{2.5} = 0.6$$

Now the forces in the members can be calculated. Consider the joint A.

**Joint A**

The reactions  $R_A$  and  $H_A$  are known in magnitude and direction. Let the directions of the forces  $F_{CA}$  and  $F_{FA}$  are as shown in Fig. 11.23 (b).

Resolving the forces vertically, we get

$$F_{CA} \times \sin \theta = 3 \text{ kN}$$

$$\therefore F_{CA} = \frac{3}{\sin \theta} = \frac{3}{0.6} = 5 \text{ kN (Compressive)}$$

Resolving the forces horizontally, we get

$$F_{FA} = F_{CA} \cos \theta + H_A = 5 \times 0.8 + 8 = 12 \text{ kN (Tensile)}$$

Now consider joint C.

**Joint C**

The force  $F_{CA}$  is known in magnitude and direction. The assumed directions of the forces  $F_{CD}$  and  $F_{CF}$  are shown in Fig. 11.23 (c).

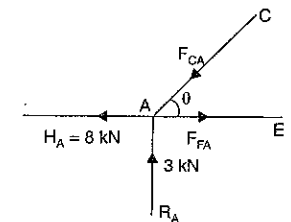

Fig. 11.23 (b)

Resolving forces vertically, we get

$$F_{CA} \sin \theta = F_{CF} \sin \theta$$

$$\therefore F_{CA} = F_{CF} = 5 \text{ kN} \quad (\because F_{CA} = 5 \text{ kN})$$

$$\therefore F_{CF} = 5 \text{ kN (Tensile)}$$

Resolving forces horizontally, we get

$$F_{CD} = F_{CA} \cos \theta + F_{CF} \cos \theta$$

$$= 5 \times 0.8 + 5 \times 0.8 = 8 \text{ kN}$$

(Compressive)

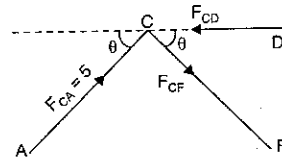

Fig. 11.23 (c)

Now consider the joint F.

**Joint F**

The forces  $F_{FA}$  and  $F_{FC}$  are known in magnitude and directions. The assumed directions of the forces  $F_{DF}$  and  $F_{GF}$  are shown in Fig. 11.23 (d).

Resolving the forces vertically, we get

$$5 \times \sin \theta + F_{DF} \sin \theta = 3$$

$$\text{or } F_{DF} = -\frac{5 \sin \theta + 3}{\sin \theta}$$

$$= -5 + \frac{3}{\sin \theta} = -5 + \frac{3}{0.6} = -5 + 5 = 0$$

Resolving the forces horizontally, we get

$$12 + 5 \cos \theta = F_{GF} + F_{DF} \cos \theta$$

$$12 + 5 \times 0.8 = F_{GF} + 0 \quad \text{or } 12 + 4 = F_{GF}$$

$$\therefore F_{GF} = 12 + 4 = 16 \text{ kN (Tensile)}$$

Now consider the joint D.

**Joint D**

The forces  $F_{DC}$  and  $F_{FD}$  are known in magnitude and direction. The assumed directions of  $F_{DG}$  and  $F_{DE}$  are shown in Fig. 11.23 (e).

Resolving vertically, we get

$$F_{DG} \sin \theta = F_{DF} \times \sin \theta = 0$$

$$\therefore F_{DG} = 0$$

Resolving forces horizontally, we get

$$F_{DE} = F_{CD} = 8 \text{ kN}$$

$$\therefore F_{DE} = 8 \text{ kN (Compressive)}$$

Now consider the joint G.

**Joint G**

The forces  $F_{DG}$  and  $F_{FG}$  are known in magnitude and direction. The assumed directions of  $F_{GE}$  and  $F_{GB}$  are shown in Fig. 11.23 (f).

Resolving the forces vertically, we get

$$F_{GE} \sin \theta = F_{DG} \sin \theta + 6 = 6$$

$$\text{or } F_{GE} = \frac{6}{\sin \theta} = \frac{6}{0.6} = 10 \text{ kN (Tensile)}$$

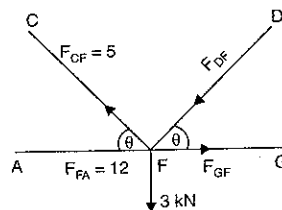

Fig. 11.23 (d)

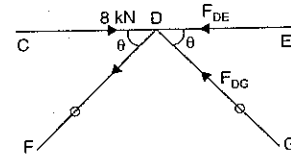

Fig. 11.23 (e)

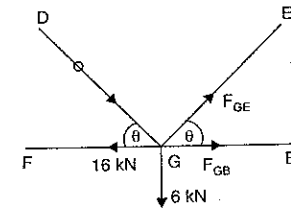

Fig. 11.23 (f)

Resolving forces horizontally, we get

$$F_{GB} = 16 - F_{GE} \cos \theta$$

$$= 16 - 10 \times 0.8 = 8 \text{ kN (Tensile)}$$

Now consider the joint E.

**Joint E**

The forces  $F_{GE}$  and  $F_{DE}$  are known in magnitude and directions. Let  $F_{BE}$  is acting in a direction as shown in Fig. 11.23 (g).

Resolving forces vertically, we get

$$F_{GE} \sin \theta = F_{BE} \sin \theta$$

$$\therefore F_{BE} = F_{GE} = 10$$

$$\therefore F_{BE} = 10 \text{ kN (Compressive)}$$

If we have calculated the forces in member BE and BG, considering joint B, we would have got the same results.

Now the forces in each member are shown in Fig. 11.23 (h).

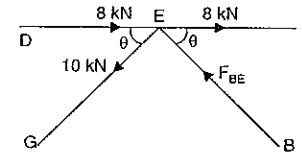

Fig. 11.23 (g)

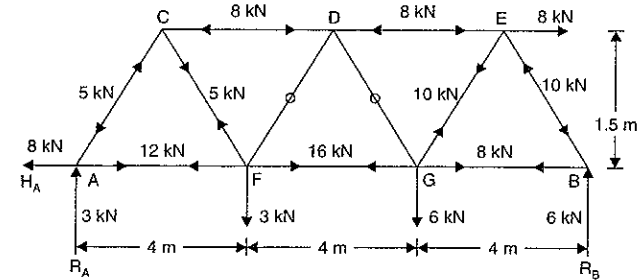

Fig. 11.23 (h)

**11.5.4. Method of Joints Applied to Trusses Carrying Inclined Loads.** If a truss carries inclined loads, hinged at one end and supported on rollers at the other end, then the support reaction at the roller supported end will be normal, whereas the support reactions at the hinged end will consists of :

- (i) Horizontal reaction and
- (ii) Vertical reaction.

The inclined loads are resolved into horizontal and vertical components.

The horizontal reaction will be obtained by adding algebraically all the horizontal components of the inclined loads ; whereas the vertical reaction will be obtained by subtracting the roller support reaction from the total vertical components of the inclined loads. Now the forces in the members of truss can be determined.

**Problem 11.10.** Determine the forces in the truss shown in Fig. 11.24 which is subjected to inclined loads.

**Sol.** The truss is supported on roller at B and hence  $R_B$  will be vertical.

The truss is hinged at A and hence the support reactions at A will consists of a horizontal reaction  $H_A$  and a vertical reaction  $R_A$ .

Now length  $AC = 4 \times \cos 30 = 4 \times 0.866 = 3.464 \text{ m}$

and length  $AD = 2 \times AC = 2 \times 3.464 = 6.928 \text{ m}$

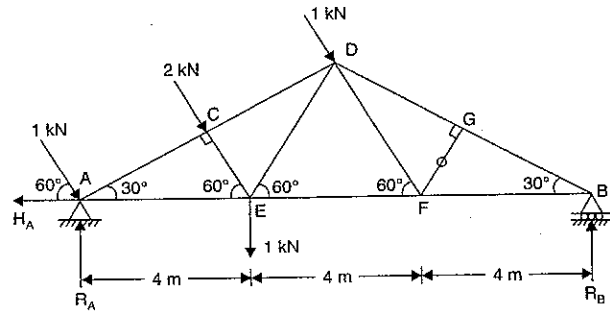

Fig. 11.24

Now taking moments about A, we get

$$R_B \times 12 = 2 \times AC + 1 \times AD + 1 \times AE$$

$$= 2 \times 3.464 + 1 \times 6.928 + 1 \times 4 = 17.856$$

$$\therefore R_B = \frac{17.856}{12} = 1.49 \text{ kN}$$

Total vertical components of inclined loads  
 $= (1 + 2 + 1) \times \sin 60^\circ$   
 $= 4 \times 0.866 = 3.464 \text{ kN}$

Total horizontal components of inclined loads  
 $= (1 + 2 + 1) \cos 60^\circ = 4 \times 0.5 = 2 \text{ kN}$

Now  $R_A =$  Vertical components of inclined loads + 1.0 -  $R_B$   
 $= 4.464 - 1.49 = 2.974 \text{ kN} (\uparrow)$

and  $H_A =$  Sum of all horizontal components = 2 kN

Now the forces in the members can be calculated.

Consider the equilibrium of joint A.

**Joint A**

Let  $F_{AE} =$  Force in member AE

and  $F_{AC} =$  Force in member AC

Their directions are assumed as shown in Fig. 11.24 (a).

Resolving the forces vertically, we get

$$F_{AC} \times \sin 30^\circ + 1 \times \sin 60^\circ = 2.974$$

or  $F_{AC} \times 0.5 + 0.866 = 2.974$

$$\therefore F_{AC} = \frac{2.974 - 0.866}{0.5}$$

$$= 4.216 \text{ kN (Compressive)}$$

Resolving the forces horizontally, we get

$$F_{AE} = 2 + F_{AC} \cos 30^\circ - 1 \times \cos 60^\circ$$

$$= 2 + 4.216 \times 0.866 - 0.5 = 5.15 \text{ kN (Tensile)}$$

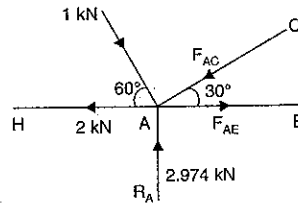

Fig. 11.24 (a)

Now consider the joint C.

**Joint C**

From Fig. 11.24 (b), we have

$$F_{CD} = F_{AC} = 4.216$$

(Compressive)

and  $F_{CE} = 2 \text{ kN}$  (Compressive)

Now consider joint E.

**Joint E** [See Fig. 11.24 (c)]

Resolving forces vertically, we get

$$1 + 2 \times \sin 60^\circ = F_{ED} \times \sin 60^\circ$$

or  $F_{ED} = 2 + \frac{1}{\sin 60^\circ} = 3.155$  (Tensile)

Resolving forces horizontally, we get

$$5.15 - 2 \times \cos 60^\circ - F_{ED} \cos 60^\circ - F_{EF} = 0$$

or  $5.15 - 2 \times \frac{1}{2} - 3.15 \times \frac{1}{2} - F_{EF} = 0$

$$F_{EF} = 5.15 - 1 - 1.57 = 2.58 \text{ kN}$$

(Tensile)

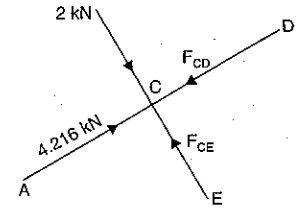

Fig. 11.24 (b)

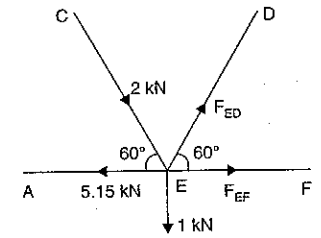

Fig. 11.24 (c)

At the joint G, two forces, i.e.,  $F_{BG}$  and  $F_{DG}$  are in the same straight line and hence the third force, i.e.,  $F_{GF}$  should be zero.

$$\therefore F_{GF} = 0$$

Now consider the joint F.

**Joint F** [See Fig. 11.24 (d)]

Resolving forces vertically, we get

$$F_{DF} \times \sin 60^\circ = 0$$

$\therefore F_{DF} = 0$

Resolving horizontally, we get

$$F_{FB} = F_{EF} = 2.58 \text{ kN}$$

$\therefore F_{FB} = 2.58 \text{ kN}$  (Compressive)

Now consider the joint B.

**Joint B**

Resolving vertically, we get

$$F_{BG} \times \sin 30^\circ = 1.49$$

$\therefore F_{BG} = \frac{1.49}{0.5} = 2.98 \text{ kN}$  (Compressive)

**Joint G**

$$F_{GD} = F_{BG} = 2.98 \text{ kN}$$

(Compressive)

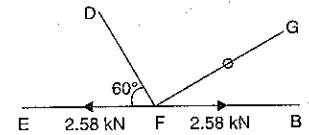

Fig. 11.24 (d)

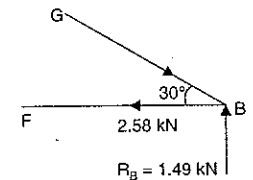

Fig. 11.24 (e)

The forces are shown in a tabular form as

Member	Force in the member	Nature of force
AC	4.216 kN	Compressive
AE	5.15 kN	Tensile
CE	2 kN	Compressive
CD	4.216 kN	Compressive
ED	3.155 kN	Tensile
EF	2.58 kN	Tensile
DF	0	Nil
DG	2.98 kN	Compressive
GB	2.98 kN	Compressive
FB	2.58 kN	Compressive
FG	0	Nil

**11.6. METHOD OF SECTIONS**

When the forces in a few members of a truss are to be determined, then the method of section is mostly used. This method is very quick as it does not involve the solution of other joints of the truss.

In this method, a section line is passed through the members, in which forces are to be determined as shown in Fig. 11.25. The section line should be drawn in such a way that it does not cut more than three members in which the forces are unknown. The part of the truss, on any one side of the section line, is treated as a free body in equilibrium under the action of external forces on that part and forces in the members cut by the section line. The unknown forces in the members are then determined by using equations of equilibrium as

$$\Sigma F_x = 0, \Sigma F_y = 0 \text{ and } \Sigma M = 0.$$

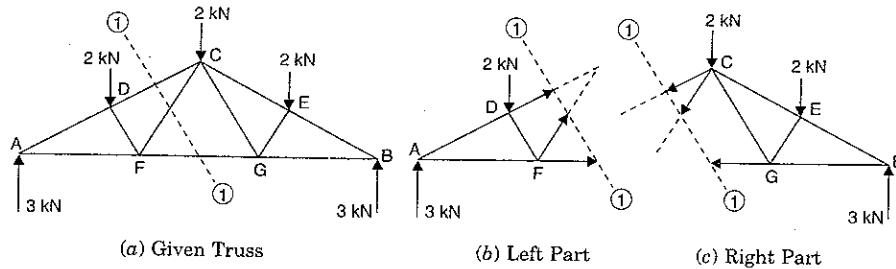

Fig. 11.25

If the magnitude of the forces, in the members cut by a section line, is positive then the assumed direction is correct. If magnitude of a force is negative, then reverse the direction of that force.

**Problem 11.11.** Find the forces in the members AB and AC of the truss shown in Fig. 11.26 using method of section.  
(U.P. Tech. University, 2002-2003)

**Sol.** First determine the reaction  $R_B$  and  $R_C$ .  
The distance of line of action of 20 kN from point B is

$$AB \times \cos 60^\circ \text{ or } 2.5 \times \frac{1}{2} = 1.25 \text{ m}$$

Taking moments about point B, we get

$$R_C \times 5 = 20 \times 1.25$$

$$\therefore R_C = \frac{20 \times 1.25}{5} = 5 \text{ kN}$$

and  $R_B = 20 - 5 = 15 \text{ kN}$

Now draw a section line (1-1), cutting the members AB and BC in which forces are to be determined. Now consider the equilibrium of the left part of the truss. This part is shown in Fig. 11.27.

Let the directions of  $F_{BA}$  and  $F_{BC}$  are assumed as shown in Fig. 11.27.

Now taking the moments of all the forces acting on the left part about point C, we get

$$15 \times 5 + (F_{BA} \times AC)^* = 0$$

( $\therefore$  The perpendicular distance between the line of action of  $F_{BA}$  and point C is equal to AC)

$$75 + F_{BA} \times 5 \times \cos 30^\circ = 0$$

or

or

$$F_{BA} = \frac{-75}{5 \times \cos 30^\circ} = -17.32 \text{ kN}$$

The negative sign shows that  $F_{BA}$  is acting in the opposite direction (i.e., towards point B). Hence force  $F_{BA}$  will be a compressive force.

$$F_{BA} = 17.32 \text{ kN (Compressive). Ans.}$$

Again taking the moments of all the forces acting on the left part about point A, we get  $15 \times$  Perpendicular distance between the line of action of

$$15 \text{ kN and point C} = F_{BC} \times \text{Perpendicular distance between } F_{BC} \text{ and point A}$$

$$15 \times 2.5 \times \cos 60^\circ = F_{BC} \times 2.5 \times \sin 60^\circ$$

$$\therefore F_{BC} = \frac{15 \times 2.5 \times \cos 60^\circ}{2.5 \times \sin 60^\circ} = \frac{15 \times 0.5}{0.866}$$

$$= 8.66 \text{ kN (Tensile). Ans.}$$

These forces are same as obtained in Problem 11.1.

**Problem 11.12.** A truss of span 5 m is loaded as shown in Fig. 11.28. Find the reactions and forces in the members marked 4, 5 and 7 using method of section.

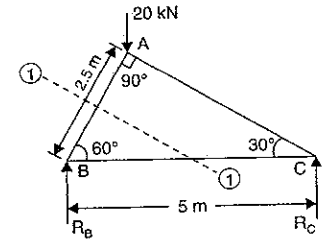

Fig. 11.26

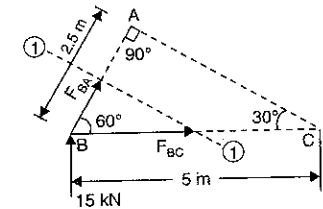

Fig. 11.27

$$(\therefore AC = BC \times \cos 30^\circ)$$

\*The moment of the force  $F_{BA}$  about point C, is also taken by resolving the force  $F_{BA}$  into vertical and horizontal components at point B. The moment of the horizontal component about C is zero, whereas the moment of vertical component will be  $(F_{BA} \times \sin 60^\circ) \times 5 = F_{BA} \times 5 \times \sin 60^\circ$  or  $F_{BA} \times 5 \times \cos 30^\circ$ .  
( $\therefore \sin 60^\circ = \cos 30^\circ$ )

**Sol.** Let us first determine the reactions  $R_A$  and  $R_B$ .

Triangle  $ABD$  is a right-angled triangle having angle

$$ADB = 90^\circ$$

$$\therefore AD = AB \cos 60^\circ = 5 \times 0.5 = 2.5 \text{ m}$$

The distance of line of action the vertical load 10 kN from point  $A$  will be  $AD \cos 60^\circ$  or  $2.5 \times 0.5 = 1.25 \text{ m}$ .

From triangle  $ACD$ , we have

$$AC = AD \cos 60^\circ = 2.5 \times 0.5 = 1.25 \text{ m}$$

$$\therefore BC = 5 - 1.25 = 3.75 \text{ m}$$

In right-angled triangle  $CEB$ , we have

$$BE = BC \cos 30^\circ = 3.75 \times \frac{\sqrt{3}}{2}$$

$\therefore$  The distance of line of action of vertical load 12 kN

from point  $B$  will be  $BE \cos 30^\circ$  or  $BE \times \frac{\sqrt{3}}{2}$

$$= \left( 3.75 \times \frac{\sqrt{3}}{2} \right) \times \frac{\sqrt{3}}{2} = 3.75 \text{ m}$$

$\therefore$  The distance of the line of action of the load of 12 kN from point  $A$  will be  $(5 - 3.75) = 1.25 \text{ m}$

Now taking the moments about  $A$ , we get

$$R_B \times 5 = 10 \times 1.25 + 12 \times 1.25 = 25$$

$$\therefore R_B = \frac{25}{5} = 5 \text{ kN} \text{ and } R_A = (10 + 12) - 5 = 17 \text{ kN}$$

Now draw a section line (1-1), cutting the members 4, 5 and 7 in which forces are to be determined. Consider the equilibrium of the right part of the truss (because it is smaller than the left part).

This part is shown in Fig. 11.29. Let  $F_4$ ,  $F_5$  and  $F_7$  are the forces in members 4, 5 and 7. Let their directions are assumed as shown in Fig. 11.29.

Now taking the moments of all the forces acting on the right part about point  $E$ , we get

$$R_B \times BE \cos 30^\circ = F_4 \times (BE \times \sin 30^\circ)$$

$$\text{or } 5 \times \left( 3.75 \times \frac{\sqrt{3}}{2} \right) \times \frac{\sqrt{3}}{2} = F_4 \times 2.5 \times \frac{\sqrt{3}}{2} \times 0.5$$

$$\text{or } 5 \times \frac{\sqrt{3}}{2} = F_4 \times 0.5$$

$$\therefore F_4 = 5 \times \frac{\sqrt{3}}{0.5} = 17.32 \text{ kN (Tensile)}$$

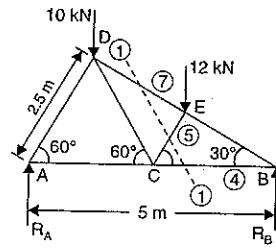

Fig. 11.28

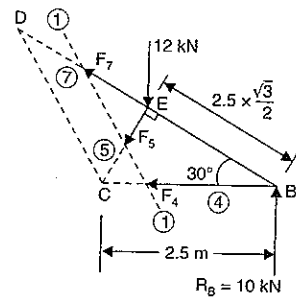

Fig. 11.29

Now taking the moments of all the forces about point  $B$  acting on the right part, we get

$$12 \times BE \cos 30^\circ + F_5 \times BE = 0$$

$$\text{or } 12 \times \cos 30^\circ + F_5 = 0$$

$$\therefore F_5 = -12 \times \cos 30^\circ = -10.392 \text{ kN}$$

-ve sign indicates that  $F_5$  is compressive.

$$\therefore F_5 = 10.392 \text{ kN (Compressive). Ans.}$$

Now taking the moments about point  $C$  of all the forces acting on the right parts, we get

$$12 \times (2.5 - BE \cos 30^\circ) = F_7 \times CE + R_B \times BC$$

$$\text{or } 12 \times \left( 2.5 - 2.5 \times \frac{\sqrt{3}}{2} \times \frac{\sqrt{3}}{2} \right) = F_7 \times 2.5 \times \sin 30^\circ + 10 \times 2.5$$

$$\text{or } 12 \times (2.5 - 1.875) = F_7 \times 1.25 + 25 \text{ or } 7.5 = 1.25F_7 + 25$$

$$\text{or } F_7 = \frac{7.5 - 25}{1.25} = -14 \text{ kN}$$

Negative sign shows that  $F_7$  is compressive.

$$\therefore F_7 = 14 \text{ kN (Compressive). Ans.}$$

These forces are same as obtained in Problem 11.3.

**Problem 11.13.** A truss of span 9 m is loaded as shown in Fig. 11.30. Find the reactions and forces in the members marked 1, 2 and 3.

**Sol.** Let us first calculate the reactions  $R_A$  and  $R_B$ .

Taking moments about  $A$ , we get

$$R_B \times 9 = 9 \times 3 + 12 \times 6 = 27 + 72 = 99$$

$$\therefore R_B = \frac{99}{9} = 11 \text{ kN}$$

and

$$R_A = (9 + 12) - 11 = 10 \text{ kN}$$

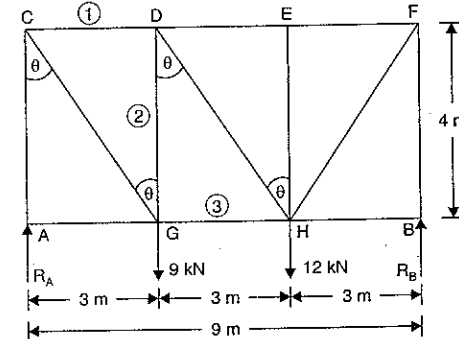

Fig. 11.30

Now draw a section line (1-1), cutting the members 1, 2 and 3 in which forces are to be determined. Consider the equilibrium of the left part of the truss (because it is smaller than

the right part). This part is shown in Fig. 11.30 (a). Let  $F_1$ ,  $F_2$  and  $F_3$  are the forces members 1, 2 and 3 respectively. Let their directions are assumed as shown in Fig. 11.30 (a).

Taking moments of all the forces acting on the left part about point  $D$ , we get

$$10 \times 3 = F_3 \times 4$$

$$F_3 = \frac{10 \times 3}{4}$$

$$= 7.5 \text{ kN (Tensile). Ans.}$$

Now taking the moments of all the forces acting on the left part about point  $G$ , we get

$$10 \times 3 + F_1 \times 4 = 0$$

$$F_1 = \frac{-30}{4} = -7.5 \text{ kN}$$

Negative sign shows that force  $F_1$  is compressive.

$$F_1 = 7.5 \text{ kN (Compressive). Ans.}$$

Now taking the moments about the point  $C$ , we get

$$F_2 \times 3 - 9 \times 3 + F_3 \times 4 = 0$$

$$F_2 \times 3 - 27 + 7.5 \times 4 = 0$$

$$(\because F_3 = 7.5)$$

$$F_2 = \frac{27 - 7.5 \times 4}{3} = \frac{-3}{3} = -1.0 \text{ kN}$$

Negative sign shows that force  $F_2$  is compressive.

$$F_2 = 1.0 \text{ kN (Compressive). Ans.}$$

**Problem 11.14.** For the pin-jointed truss shown in Fig. 11.31, find the forces in the members marked 1, 2 and 3 with the single load of 80 kN as shown.

**Sol.** First calculate reactions  $R_A$  and  $R_B$ .

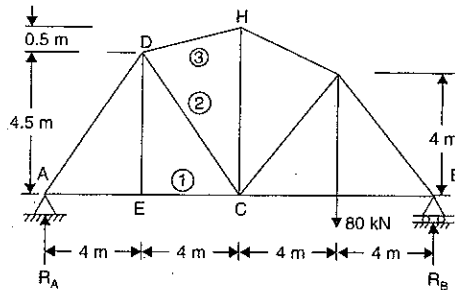

Fig. 11.31

Taking moments about A,  $R_B \times 16 = 80 \times 12$

$$R_B = \frac{80 \times 12}{16} = 60 \text{ kN}$$

$$R_A = \text{Total vertical load} - R_B = 80 - 60 = 20 \text{ kN}$$

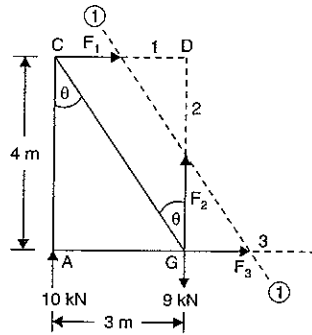

Fig. 11.30 (a)

Let us now find the forces in the members 1, 2 and 3 by the method of section. Take a section Y-Y passing through the members 1, 2 and 3. Now consider the equilibrium of left portion shown in Fig. 11.31 (a).

Let  $F_1$ ,  $F_2$  and  $F_3$  are the forces in the members 1, 2 and 3 respectively. Their assumed directions are also shown in Fig. 11.31 (a).

Taking moments of all forces (here  $R_A$ ,  $F_1$ ,  $F_2$  and  $F_3$ ) about point  $D$ , we get

$$R_A \times 4 = F_1 \times 4.5$$

$$\therefore F_1 = \frac{R_A \times 4}{4.5} = \frac{20 \times 4}{4.5}$$

$$= 17.78 \text{ kN (Tensile). Ans.}$$

Now taking the moments about  $C$ , we get

$$R_A \times 8 = F_3 \times \text{Perpendicular distance between } F_3 \text{ and point } C \quad \dots(i)$$

To find the perpendicular distance between the line of action of  $F_3$  and point  $C$ , first find angle  $CDH$

$$\tan \theta = \frac{DE}{EC} = \frac{4.5}{4.0}$$

$$\theta = \tan^{-1} \frac{4.5}{4.0} = 48.37^\circ \text{ and } \tan \alpha = \frac{0.5}{4.0}$$

$$\alpha = \tan^{-1} \frac{0.5}{4.0} = 7.125^\circ$$

$$\therefore \angle CDH = \theta + \alpha = 48.37 + 7.125 = 55.495$$

From triangle  $DEC$ , we know that

$$CD = \sqrt{4.5^2 + 4^2} = 6.02 \text{ m}$$

Now from  $C$ , draw a perpendicular  $CL$  on the line of action of  $F_3$  as shown in Fig. 11.31 (b).

$\therefore$  From right-angled triangle  $CDL$ ,

$$\sin(\alpha + \theta) = \frac{CL}{CD}$$

$$CL = CD \sin(\alpha + \theta) = 6.02 \times \sin(55.495) = 4.96 \text{ m}$$

Substituting the value of  $OL$  (i.e., perpendicular distance between  $F_3$  and  $C$ ) in equation (i), we get

$$R_A \times 8 = F_3 \times 4.96$$

$$\therefore F_3 = \frac{R_A \times 8}{4.96} = \frac{20 \times 8}{4.96} = 32.26 \text{ kN (Compressive). Ans.}$$

To find the force  $F_2$ , resolve the forces (i.e.,  $R_A$ ,  $F_3$ ,  $F_2$  and  $F_1$ ) vertically. Hence, we get

$$R_A - F_3 \sin \alpha + F_2 \sin \theta = 0$$

$$\text{or } 20 - 32.26 \times \sin(7.125) + F_2 \times \sin(48.37) = 0$$

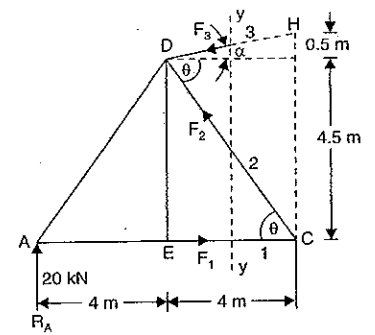

Fig. 11.31 (a)

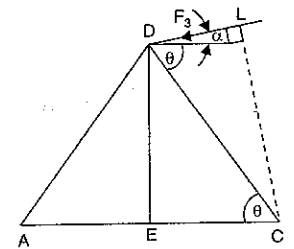

Fig. 11.31 (b)

or  $20 - 4 + F_2 \times 0.7474 = 0$

or  $F_2 = \frac{16}{0.7474} = 21.4 \text{ kN (Compressive). Ans.}$

**11.6.1. Method of Section, Cutting more than Three Members.** In method of section, in general a section should cut only three members, since only three unknowns can be determined from three equations of equilibrium. However, there are special cases where we may cut more than three members. It is illustrated in the following example. A section line can cut four members if the axes of the three of them intersect in one point, thus making it possible to determine the axial force in the fourth member by taking moments about the point of intersection of the axes of the three members.

**Problem 11.15.** For the frame shown in Fig. 11.32 find the forces in the members  $BD$ ,  $BG$ ,  $GA$ ,  $AC$  and  $AB$  of the bottom bay only. State their nature.

**Sol.** Let us first find the reactions. The frame carries horizontal loads. As the frame is supported on rollers at  $B$ , hence the reaction  $R_B$  will be vertical.

At the point  $A$ , the frame is hinged and hence the support reactions at  $A$  will consist of a horizontal reaction  $H_A$  and a vertical reaction  $R_A$ .

Taking moments of all forces about  $A$ , we get

$$R_B \times 4 = 20 \times 2 + 20 \times 4 + 20 \times 6 = 240$$

$$\therefore R_B = \frac{240}{4} = 60 \text{ kN } (\uparrow)$$

Now  $R_A = \text{Total vertical loads} - R_B$   
 $= 0 - 60 = -60 \text{ kN}$

-ve sign means,  $R_A$  is acting downwards.

$$\therefore R_A = 60 \text{ kN } (\downarrow)$$

and  $H_A = \text{Sum of all horizontal loads}$   
 $= (20 + 20 + 20) = 60 \text{ kN } (\leftarrow)$

Now draw a section line (1-1), cutting the members  $BD$ ,  $BG$  and  $BA$  in which forces are to be determined. Consider the equilibrium of the right part. This part is shown in Fig. 11.32 (a). Let  $F_{BD}$ ,  $F_{BG}$  and  $F_{BA}$  are the forces in the members  $BD$ ,  $BG$  and  $BA$  respectively. Let their directions are assumed as shown in Fig. 11.32 (a).

In this particular case, all the three forces are meeting at one point  $B$ . Hence by cutting these members by section line (1-1), we may not get the results.

Let us draw a section line (2-2), cutting four members  $AC$ ,  $CG$ ,  $GD$  and  $BD$  in which forces are to be determined. The axes of three members, i.e.,  $AC$ ,  $CG$  and  $GD$  are intersecting at point  $C$ . And hence taking moments about point  $C$ , we can find force in member  $BD$ .

Similarly the axes of  $BD$ ,  $GD$  and  $CG$  are meeting at point  $D$ . And hence taking moments about point  $D$ , we can find the force in member  $AC$ .

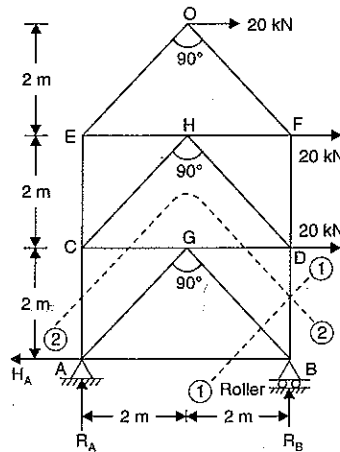

Fig. 11.32

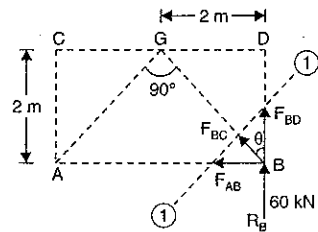

Fig. 11.32 (a)

The section line (2-2), cutting the four members, is shown in Fig. 11.32 (b). Let the forces in the members are  $F_{CA}$ ,  $F_{CG}$ ,  $F_{DG}$  and  $F_{BD}$ . Let their directions are assumed as shown in Fig. 11.32 (b). Consider the equilibrium of part above the section line (2-2). Taking the moments of all the forces (acting on the upper part) about point  $C$ , we get

$$20 \times 2 + 20 \times 4 + F_{BD} \times 4 = 0$$

or  $F_{BD} = \frac{-40 - 80}{4} = \frac{-120}{4} = -30 \text{ kN}$

-ve sign means the force  $F_{BD}$  is compressive.

$$\therefore F_{BD} = 30 \text{ kN (Compressive). Ans.}$$

Now taking moments of all forces (acting on the upper part) about point  $D$ , we get

$$F_{CA} \times 4 = 20 \times 2 + 20 \times 4 = 120$$

$$\therefore F_{CA} = \frac{120}{4} = 30 \text{ kN (Tensile). Ans.}$$

Now consider joint  $B$ .

**Joint B**

Resolving forces vertically, we get

$$F_{BG} \cos 45^\circ + F_{BD} = R_B$$

$$F_{BG} \times \cos 45^\circ + 30 = 60$$

or

or  $F_{BG} = \frac{60 - 30}{\cos 45^\circ} = \frac{30}{1/\sqrt{2}} = 30 \times \sqrt{2} \text{ (Compressive)}$

Resolving horizontally, we get

$$F_{BA} = F_{BG} \sin 45^\circ = 30 \times \sqrt{2} \times \frac{1}{\sqrt{2}} = 30 \text{ kN (Tensile)}$$

Now consider joint  $A$ .

**Joint A**

At the joint  $A$ ;  $R_A$ ,  $H_A$ ,  $F_{AC}$  and  $F_{AB}$  are known in magnitude and direction.

Resolving horizontally, we get

$$60 = 30 + F_{AG} \times \cos 45^\circ$$

$$\therefore F_{AG} = \frac{60 - 30}{\cos 45^\circ} = \frac{30}{1/\sqrt{2}} = 30 \times \sqrt{2} \text{ (Tensile)}$$

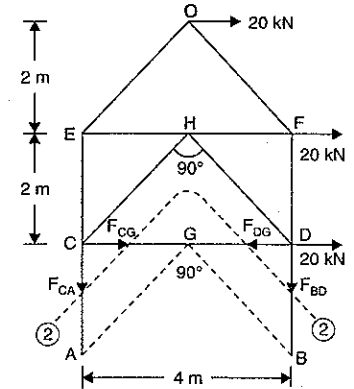

Fig. 11.32 (b)

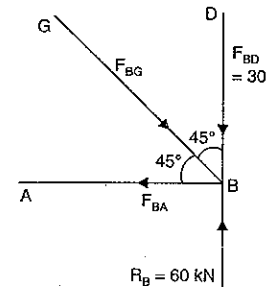

Fig. 11.32 (c)

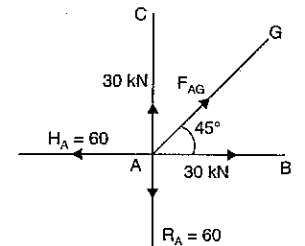

Fig. 11.32 (d)

Now the forces are shown in a tabular form below :

Member	Force in the member	Nature of force
BD	30 kN	Compressive
BG	$30 \times \sqrt{2}$ kN	Compressive
AB	30 kN	Tensile
AC	30 kN	Tensile
AG	$30 \times \sqrt{2}$	Tensile

**Problem 11.16.** A truss of 12 m span is loaded as shown in Fig. 11.33. Determine the forces in the members DG, DF and EF, using method of section.

**Sol.** The truss is supported on rollers at B and hence  $R_B$  will be vertical. The truss is hinged at A and hence the support sections at A will consists of a horizontal section  $H_A$  and a vertical section  $R_A$ .

In triangle AEC,  $AC = AE \times \cos 30^\circ$   
 $= 4 \times 0.866 = 3.464$  m

Now length  $AD = 2 \times AC = 2 \times 3.464$   
 $= 6.928$  m

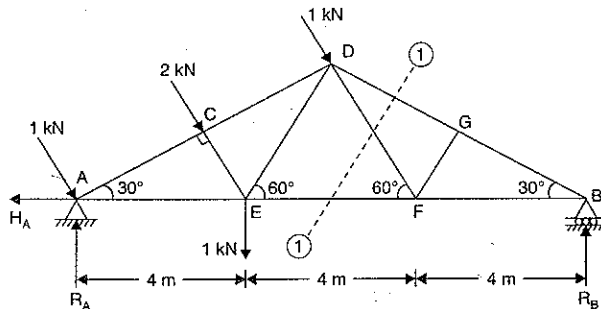

Fig. 11.33

Now taking the moments about A, we get

$$R_B \times 12 = 2 \times AC + 1 \times AD + 1 \times AE$$

$$= 2 \times 3.464 + 1 \times 6.928 + 1 \times 4 = 17.856$$

$$\therefore R_B = \frac{17.856}{12} = 1.49 \text{ kN}$$

Now draw the section line (1-1), passing through members DG, DF and EF in which the forces are to be determined. Consider the equilibrium of the right part of the truss. This part is shown in Fig. 11.33 (a). Let  $F_{DG}$ ,  $F_{FD}$  and  $F_{EF}$  are the forces in members DG, FD and EF respectively. Let their directions are assumed as shown in Fig. 11.33 (a). Taking moments of all forces acting on right part about point F, we get

$$R_B \times 4 + F_{DG} \times FG = 0$$

or  $1.49 \times 4 + F_{DG} \times (4 \times \sin 30^\circ) = 0$  ( $\because FG = 4 \times \sin 30^\circ$ )

or  $F_{DG} = \frac{-1.49 \times 4}{4 \times \sin 30^\circ} = -2.98 \text{ kN}$

- ve sign shows that the force  $F_{DG}$  is compressive.

$\therefore F_{DG} = 2.98 \text{ kN (Compressive). Ans.}$

Now taking the moments about point D, we get

$$R_B \times BD \cos 30^\circ = F_{FE} \times BD \times \sin 30^\circ$$

or  $R_B \times \cos 30^\circ = F_{FE} \times \sin 30^\circ$

$$\therefore F_{FE} = \frac{1.49 \times \cos 30^\circ}{\sin 30^\circ} = \frac{1.49 \times 0.866}{0.5}$$

$$= 2.58 \text{ kN (Tensile). Ans.}$$

Now taking the moments of all forces acting on the right part about B, we get

$$F_{FD} \times \perp \text{ distance between } F_{FD} \text{ and } B = 0$$

$\therefore F_{FD} = 0. \text{ Ans.}$

( $\because \perp$  distance between  $F_{FD}$  and B is not zero)

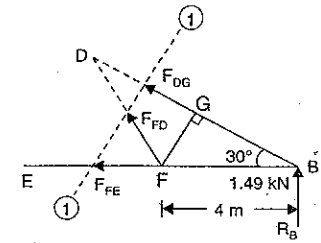

Fig. 11.33 (a)

**11.7. GRAPHICAL METHOD**

The force in a perfect frame can also be determined by a graphical method. The analytical methods (such as method of joints and method of sections) give absolutely correct results, but sometimes it is not possible to get the results from analytical methods. Then a graphical method can be used conveniently to get the results. The graphical method also provides reasonable accurate results.

The naming of the various members of a frame are done according to Bow's notations. According to this notation of force is designated by two capital letters which are written on either side of the line of action of the force. A force with letters A and B on either side of the line of action is shown in Fig. 11.34. This force will be called AB.

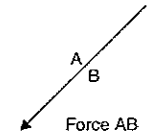

Fig. 11.34

The following steps are necessary for obtaining a graphical solution of a frame.

- (i) Making a space diagram
- (ii) Constructing a vector diagram
- (iii) Preparing a force table.

**1. Making a space diagram.** The given truss or frame is drawn accurately according to some linear scale. The loads and support reactions in magnitude and directions are also shown on the frame. Then the various members of the frame are named according to Bow's notation. Fig. 11.35 (a) shows a given truss and the forces in the members AB, BC and AC are to be determined. Fig. 11.35 (b) shows the space diagram to same linear scale. The member AB is named as PS and so on.

**2. Constructing a vector diagram.** Fig. 11.35 (c) shows a vector diagram, which is drawn as given below :

- (i) Take any point p and draw pq parallel to PQ vertically downwards. Cut pq = 4 kN to same scale.
- (ii) Now from q draw qr parallel to QR vertically upwards and cut qr = 2 kN to the same scale.



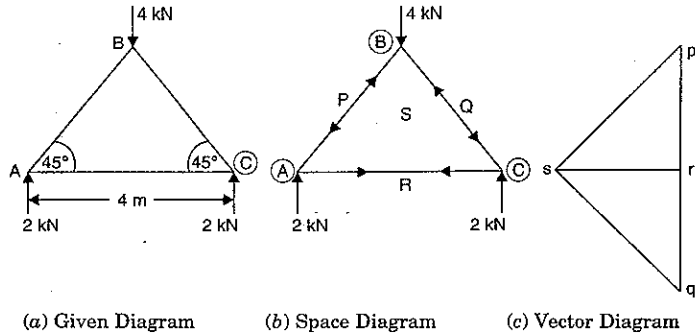

Fig. 11.35

(iii) From  $r$  draw  $rp$  parallel to  $RP$  vertically upwards and cut  $rp = 2$  kN to the same scale.  
 (iv) Now from  $p$ , draw a line  $ps$  parallel to  $PS$  and from  $r$ , draw a line  $rs$  parallel to  $RS$ , meeting the first line at  $s$ . This is vector diagram for joint (A). Similarly the vector diagrams for joint (B) and (C) can be drawn.

**3. Preparing a force table.** The magnitude of a force in a member is known by the length of the vector diagram for the corresponding member, i.e., the length  $ps$  of the vector diagram will give the magnitude of force in the member  $PS$  of the frame.

Nature of the force (i.e., tensile or compressive) is determined according to the following procedure :

(i) In the space diagram, consider any joint. Move round that joint in a *clockwise direction*. Note the order of two capital letters by which the members are named. For example, the members at the joint (A) in space diagram Fig. 11.35 (b) are named as  $PS$ ,  $SR$  and  $RP$ .

(ii) Now consider the vector diagram. Move on the vector diagram in the order of the letters (i.e.,  $ps$ ,  $sr$  and  $rp$ ).

(iii) Now mark the arrows on the members of the space diagram of that joint (here joint A).

(iv) Similarly, all the joints can be considered and arrows can be marked.

(v) If the arrow is pointing towards the joint, then the force in the member will be compressive whereas if the arrow is away from the joint, then the force in the member will be tensile.

**Problem 11.17.** Find the forces in the members  $AB$ ,  $AC$  and  $BC$  of the truss shown in Fig. 11.36.

**Sol.** First determine the reactions  $R_B$  and  $R_C$ .

From Fig. 11.36 (a),  $AB = BC \times \cos 60^\circ = 5 \times \frac{1}{2} = 2.5$  m

Distance of line of action of 20 kN from point B

$$= AB \cos 60^\circ = 2.5 \times \frac{1}{2} = 1.25 \text{ m}$$

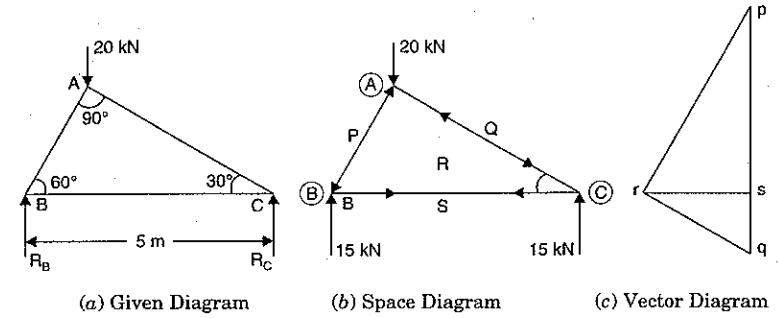

Fig. 11.36

Now taking moments about B, we get

$$R_C \times 5 = 20 \times 1.25 = 25$$

$$R_C = \frac{25}{5} = 5 \text{ kN} \quad \text{and} \quad R_B = 20 - 5 = 15 \text{ kN}$$

Now draw the space diagram for the truss alongwith load of 20 kN and the reactions  $R_B$  and  $R_C$  equal to 15 kN and 5 kN respectively as shown in Fig. 11.36 (b). Name the members  $AB$ ,  $AC$  and  $BC$  according to Bow's notations as  $PR$ ,  $QR$  and  $RS$  respectively. Now construct the vector diagram as shown in Fig. 11.36 (c) and as explained below :

(i) Take any point  $p$  and draw a vertical line  $pq$  downward equal to 20 kN to some suitable scale. From  $q$  draw a vertical line  $qs$  upward equal to 5 kN to the same scale to represent the reaction at C. Then  $sp$  will represent the reaction  $R_B$  to the scale.

(ii) Now draw the vector diagram for the joint (B). From  $p$ , draw a line  $pr$  parallel to  $PR$  and from  $s$  draw a line  $sr$  parallel to  $SR$ , meeting the first line at  $r$ . Now  $prs$  is the vector diagram for the joint (B). Now mark the arrows on the joint B. The arrow in member  $PR$  will be towards joint B, whereas the arrow in the member  $RS$  will be away from the joint B as shown in Fig. 11.36 (b).

(iii) Similarly draw the vector diagrams for joint A and C. Mark the arrows on these joints in space diagram.

Now measure the various sides of the vector diagram. The forces are obtained by multiplying the scale factor. The forces in the members are given in a tabular form as :

Member		Force in member	Nature of force
According to given truss	According to Bow's notation		
AB	PR	17.3 kN	Compressive
AC	QR	10.0 kN	Compressive
BC	RS	8.7 kN	Tensile

**Problem 11.18.** A truss of span 7.5 m carries a point load of 1000 N at joint D as shown in Fig. 11.37. Find the reactions and forces in the member of the truss.

Sol. First determine the reactions  $R_A$  and  $R_B$ .

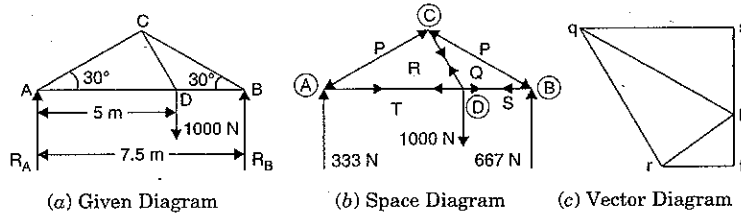

Fig. 11.37

Taking moments about A, we get

$$R_B \times 7.5 = 5 \times 1000$$

$$R_B = \frac{5000}{7.5} = 667 \text{ N and } R_A = 1000 - 667 = 333 \text{ N.}$$

Now draw the space diagram for the truss along with load of 1000 N and reactions  $R_A$  and  $R_B$  equal to 333 N and 667 N respectively as shown in Fig. 11.37 (b). Name the members AC, CB, AD, CD and DB according to Bow's notations as PR, PQ, RT, QR and QS respectively. Now construct the vector diagram as shown in Fig. 11.37 (c) and as explained below :

(i) Take any point s and draw a vertical line st downward equal to load 1000 N to some suitable scale. From t draw a vertical line tp upward equal to 333 N to the same scale to represent the reaction at A. The ps will represent the reaction  $R_B$  to the scale.

(ii) Now draw the vector diagram for the joint A. From p, draw a line pr parallel to PR and from t draw a line tr parallel to RT, meeting the first line at r. Now prt is the vector diagram for the joint A. Now mark the arrows on the joint A. The arrow in the member PR will be towards the joint A, whereas the arrow in the member RT will be away from the joint A as shown in Fig. 11.37 (b).

(iii) Similarly draw the vector diagrams for the joint C, B and D. Mark the arrows on these joints as shown in Fig. 11.37 (b).

Now measure the various sides of the vector diagrams. The forces in the members are obtained by multiplying the scale factor to the corresponding sides of the vector diagram. The forces in members are given in a tabular form as :

Member		Force in member	Nature of force
According to given truss	According to Bow's notation		
AC	PR	666 N	Compressive
AD	RT	576.7 N	Tensile
CB	PQ	1333 N	Compressive
CD	QR	1155 N	Tensile
DB	QS	1555 N	Tensile

**Problem 11.19.** Determine the forces in all the members of a cantilever truss shown in Fig. 11.38.

Sol. In this case the vector diagram can be drawn without knowing the reactions. First of all draw the space diagram for the truss along with loads of 1000 N of joints B and C. Name the members AB, BC, CD, DE, AD and BD according to Bow's notation as PT, QS, SR, RV, VT and ST respectively. Now construct the vector diagram as shown in Fig. 11.38 (c) and as explained below :

(i) The vector diagram will be started from joint C where forces in two members are unknown. Take any point q and draw a vertical line qr downward equal to load 1000 N to some suitable scale. From r, draw a line rs parallel to RS and from q draw a line qs parallel to QS, meeting the first line at s. Now qrs is the vector diagram for the joint C. Now mark the arrows on the joint C. The arrow in the member RS will be towards the joint C, whereas the arrow in the member SQ will be away from the joint C as shown in Fig. 11.38 (b).

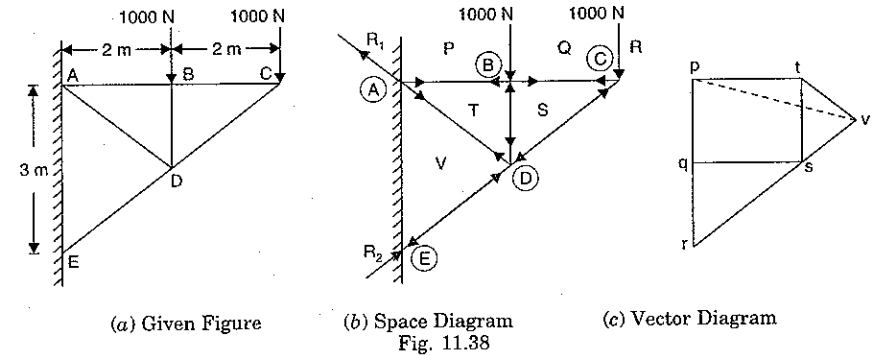

Fig. 11.38

(ii) Now draw the vector diagram for the joints B and D similarly.

Mark the arrows on these joints as shown in Fig. 11.38 (b).

Now measure the various sides of the vector diagram. The forces in the members are given in a tabular form as :

Member		Force in member	Nature of force
According to given truss	According to Bow's notation		
AB	PT	1333 N	Tensile
BC	QS	1333 N	Tensile
CD	SR	1666 N	Compressive
DE	RV	2500 N	Compressive
AD	VT	833 N	Tensile
BD	ST	1000 N	Compressive

From the vector diagram, the reactions  $R_1$  and  $R_2$  at A and E can be determined in magnitude and directions.

Reaction  $R_2 = rv = 2500 \text{ N}$ . This will be towards point E.

Reaction  $R_1 = vp = 2000$  N. This will be away from the point A as shown in Fig. 11.38 (b). The reaction  $R_1$  is parallel to  $vp$ .

**Problem 11.20.** Determine the support reactions and nature and magnitude of forces in the members of truss shown in Fig. 11.39.

(U.P. Tech. University, 2001-2002)

**Sol.** Let us start from joint A where forces in two members are unknown.

**Joint A**

In triangle ABC,

$$\tan \theta = \frac{BC}{CA} = \frac{2}{4}$$

$$\therefore \cos \theta = \frac{AC}{AB} = \frac{4}{\sqrt{2^2 + 4^2}} = \frac{4}{\sqrt{20}}$$

and

$$\sin \theta = \frac{2}{\sqrt{20}}$$

Refer to Fig. 11.39 (a). The forces are shown at joint A. Resolving forces vertically, we get

$$F_{AB} \sin \theta = 200$$

$$\therefore F_{AB} = \frac{200}{\sin \theta} = \frac{200}{2/\sqrt{20}} = \frac{200 \times \sqrt{20}}{2} = 447.2 \text{ kN. Ans.}$$

Resolving forces horizontally, we get

$$F_{AC} = F_{AB} \cos \theta = (100 \times \sqrt{20}) \times \frac{4}{\sqrt{20}} = 400 \text{ kN (Tensile).}$$

**Joint B**

Refer to Fig. 11.39(b)

$$\angle ABC = 90 - \theta$$

Resolving forces vertically,

$$F_{BC} = F_{AB} \cos (90 - \theta) = F_{AB} \sin \theta$$

$$= (100 \times \sqrt{20}) \times \frac{2}{\sqrt{20}}$$

$$\left( \because F_{AB} = 100 \times \sqrt{20} \text{ and } \sin \theta = \frac{2}{\sqrt{20}} \right)$$

$$\therefore F_{BC} = 200 \text{ kN (Tensile)}$$

Resolving forces horizontally, we get

$$F_{BD} = F_{AB} \sin (90 - \theta) = F_{AB} \cos \theta = (100 \times \sqrt{20}) \times \frac{4}{\sqrt{20}} = 400 \text{ kN (Comp.)}$$

**Joint C**

Refer to Fig. 11.39(c)

Resolving forces horizontally,

$$F_{CE} \cos \theta + F_{CD} \cos \theta = F_{AC}$$

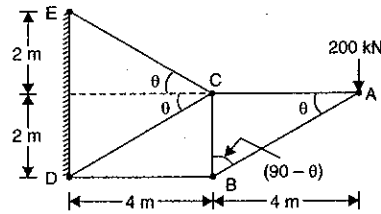

Fig. 11.39

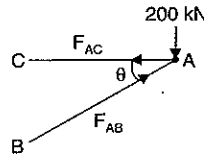

Fig. 11.39 (a)

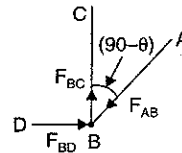

Fig. 11.39 (b)

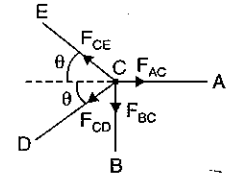

Fig. 11.39 (c)

$$\left( \because F_{BC} = 200 \text{ kN} \right)$$

$$\left( \because \sin \theta = \frac{2}{\sqrt{20}} \right)$$

...(ii)

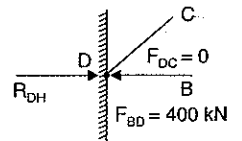

Fig. 11.39 (d)

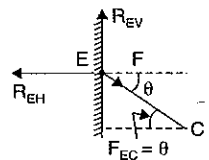

Fig. 11.39 (e)

or 
$$F_{CE} \times \frac{4}{\sqrt{20}} + F_{CD} \times \frac{4}{\sqrt{20}} = 400$$

$$\therefore F_{CE} + F_{CD} = 400 \times \frac{\sqrt{20}}{4} = 100 \times \sqrt{20} \quad \dots(i)$$

Resolving forces vertically, we get

$$F_{CE} \sin \theta - F_{CD} \sin \theta - F_{BC} = 0$$

$$(F_{CE} - F_{CD}) \sin \theta = F_{BC} = 200$$

or

$$\therefore F_{CE} - F_{CD} = \frac{200}{\sin \theta} = \frac{200}{\left( \frac{2}{\sqrt{20}} \right)} = 100 \times \sqrt{20}$$

Adding equation (i) and (ii),

$$2F_{CE} = 200 \times \sqrt{20}$$

or

$$F_{CE} = 100 \times \sqrt{20} \text{ (Tensile)}$$

Substituting this value in equation (i), we get

$$F_{CD} = 100 \times \sqrt{20} - 100 \times \sqrt{20} = 0$$

**Support Reactions**

To find the support reactions, consider joint D and E.

**Joint D**

The force  $F_{BD} = 400$  kN

whereas  $F_{DC} = 0$ . Hence at joint D, there will be only horizontal reaction  $R_{DH}$ , which will balance force  $F_{BD}$ .

$$\therefore R_{DH} = F_{BD} = 400 \text{ kN.}$$

**Joint E**

At joint E, the force  $F_{EC} = 100 \times \sqrt{20}$  kN. To balance this force, there will be horizontal reaction and vertical reaction at E.

Let  $R_{EV}$  = Vertical component of reaction at E

$R_{EH}$  = Horizontal component of reaction at E

Resolving forces horizontally, we get

$$R_{EH} = F_{EC} \cos \theta = (100 \times \sqrt{20}) \times \frac{4}{\sqrt{20}} = 400 \text{ kN. Ans.}$$

Resolving forces vertically, we get

$$R_{EV} = F_{EC} \sin \theta = (100 \times \sqrt{20}) \times \frac{2}{\sqrt{20}} = 200 \text{ kN. Ans.}$$

Now the nature and magnitude of forces in the members are:

- AB  $\rightarrow$  447.2 kN (Compressive)
- BC  $\rightarrow$  200 kN (Tensile)
- AC  $\rightarrow$  400 kN (Tensile)
- BD  $\rightarrow$  400 kN (Compressive)
- CD  $\rightarrow$  0
- CE  $\rightarrow$  447.2 kN (Tensile).

## HIGHLIGHTS

- The relation between number of joints ( $j$ ) and number of members ( $n$ ) in a perfect frame is given by  $n = 2j - 3$ .
- Deficient frame is a frame in which number of members are less than  $(2j - 3)$  whereas a redundant frame is a frame in which number of members are more than  $(2j - 3)$ .
- The reaction on a roller support is at right angles to the roller base :
- The forces in the members of a frame are determined by :
  - Method of joints
  - Method of sections, and
  - Graphical method.
- The force in a member will be compressive if the member pushes the joint to which it is connected whereas the force in the member will be tensile if the member pulls the joint to which it is connected.
- While determining forces in a member by method of joints, the joint should be selected in such a way that at any time there are only two members, in which the forces are unknown.
- If three forces act at a joint and two of them are along the same straight line then third force would be zero.
- If a truss (or frame) carries horizontal loads, then the support reaction at the hinged end will consist of (i) horizontal reaction and (ii) vertical reaction.
- If a truss carries inclined loads, then the support reaction at the hinged end will consist of :
  - horizontal reaction and (ii) vertical reaction. They will be given as :  
 Horizontal reaction = Horizontal components of inclined loads  
 Vertical reaction = Total vertical components of inclined loads - Roller support reaction.
- Method of section is mostly used, when the forces in a few members of a truss are to be determined.
- The following steps are necessary for obtaining a graphical solution of a frame :
  - Making a space diagram,
  - Constructing a vector diagram, and
  - Preparing a force table.
- The various members of a frame are named according to Bow's notation.

## EXERCISE 11

## A. Theoretical Questions

- Define and explain the terms : Perfect frame, imperfect frame and a redundant frame.  
(U.P. Tech. University, 2002-2003)
- (a) What is a frame ? State the difference between a perfect frame and an imperfect frame.  
(b) What are the assumptions made in finding out the forces in a frame ?
- What are the different methods of analysing (or finding out the forces) a perfect frame ? Which one is used where and why ?
- How will you find the forces in the members of a truss by method of joints when
  - the truss is supported on rollers at one end and hinged at other end and carries vertical loads.
  - the truss is acting as a cantilever and carries vertical loads.
  - the truss is supported on rollers at one end and hinged at other end and carries horizontal and vertical loads.

- the truss is supported on rollers at one end and hinged at other end and carries inclined loads.
- (a) What is the advantage of method of section over method of joints ? How will you use method of section in finding forces in the members of a truss ?  
(b) Explain with simple sketches the terms (i) method of sections and (ii) method of joints, as applied to trusses.
  - How will you find the forces in the members of a joint by graphical method ? What are the advantages or disadvantages of graphical method over method of joints and method of section ?
  - What is the procedure of drawing a vector diagram for a frame ? How will you find out (i) magnitude of a force, and (ii) nature of a force from the vector diagram ?
  - How will you find the reactions of a cantilever by graphical method ?
  - What are the assumptions made in the analysis of a simple truss.
  - Explain what you understand by perfect frame, deficient frame and redundant frame.

## B. Numerical Problems

- Find the forces in the members  $AB$ ,  $AC$  and  $BC$  of the truss shown in Fig. 11.40.

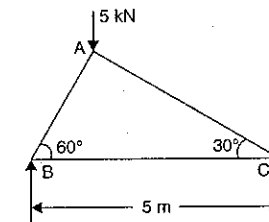

Fig. 11.40

[Ans.  $AB = 4.33$  kN (Comp.)  
 $AC = 2.5$  kN (Comp.)  
 $BC = 2.165$  kN (Tens.)]

- A truss of span 7.5 m carries a point load of 500 N at joint  $D$  as shown in Fig. 11.41. Find the reactions and forces in the members of the truss.

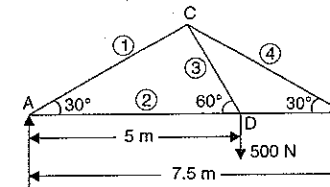

Fig. 11.41

[Ans.  $R_A = 166.5$  N  
 $R_B = 333.5$  N  
 $F_1 = 333$  N (Comp.)  
 $F_2 = 288.5$  N (Tens.)  
 $F_3 = 577.5$  N (Tens.)  
 $F_4 = 667$  N (Comp.)  
 $F_5 = 577.5$  N (Tens.)]

- A truss of span 7.5 m is loaded as shown in Fig. 11.42. Find the reactions and forces in the members of the truss.

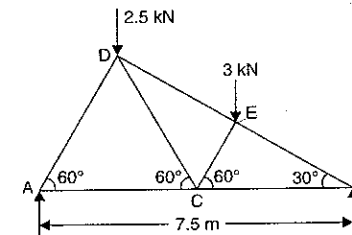

Fig. 11.42

[Ans.  $AD = 3.464$  kN (Comp.)  
 $AC = 1.732$  kN (Tens.)  
 $CD = 2.598$  kN (Tens.)  
 $CE = 2.598$  kN (Comp.)  
 $DE = 3.50$  kN (Comp.)  
 $BE = 5$  kN (Comp.)  
 $BC = 4.33$  kN (Tens.)]

4. A truss is shown in Fig. 11.43. Find the forces in all the members of the truss and indicate it is in tension or compression.

(U.P. Tech. University 2000-2001)

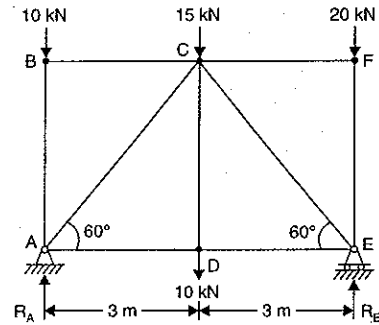

Fig. 11.43

[Hint. In the problem, length of members are not given. Assume  $AD = DE = 3$  m and  $\angle DAC = \angle DEC = 60$  as from figure it appears that  $AD = DE$  and  $\angle DAC = \angle DEC$

$$M_A = 0, 10 \times 3 + 15 \times 3 + 20 \times 6 - 6 \times R_E = 0,$$

or 
$$R_E = \frac{30 + 45 + 120}{6} = 32.5 \text{ kN}$$

and 
$$R_A = 10 + 15 + 20 + 10 - R_E = 55 - 32.5 = 22.5$$

Start from joint B where forces in two members are unknown

**Joint B**

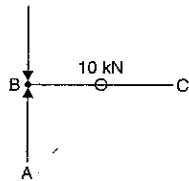

$$F_{BA} = 10 \text{ kN (Comp.)}$$

$$F_{BC} = 0$$

**Joint A**

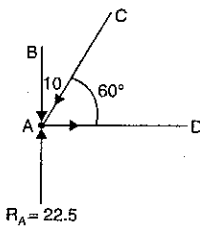

$$\Sigma V = 0$$

$$22.5 - 10 - F_{AC} \sin 60^\circ = 0$$

$$\therefore F_{AC} = \frac{12.5}{\sin 60^\circ} = 14.43 \text{ kN}$$

**Joint D**

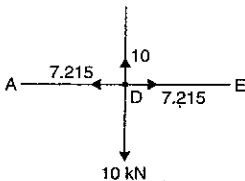

$$\Sigma H = 0, F_{AD} = F_{AC} \cos 60^\circ = 7.215$$

**Joint F**

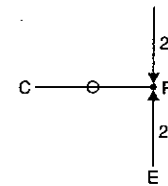

$$F_{FE} = 20 \text{ kN (Comp.)}$$

$$F_{FC} = 0$$

**Joint E**

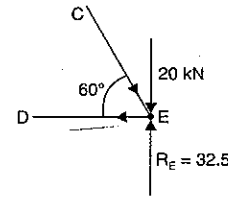

$$\Sigma V = 0, 32.5 - 20 - F_{CE} \sin 60^\circ = 0$$

$$\frac{12.5}{\sin 60^\circ} = F_{CE} = 14.43 \text{ kN}$$

$$\Sigma H = 0, F_{ED} = F_{CE} \cos 60^\circ = 7.215 \text{ kN}$$

5. Determine the forces in the various members of the truss shown in Fig. 11.44.

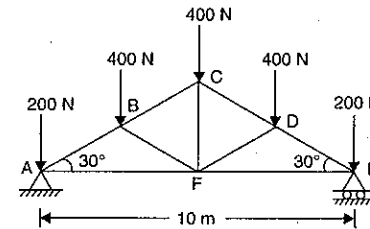

Fig. 11.44

- [Ans.  $AB = 1200$  N (Comp.)  
 $BC = 800$  N (Comp.)  
 $CD = 800$  N (Comp.)  
 $DE = 1200$  N (Comp.)  
 $EF = 600$  N (Tens.)  
 $AF = 600$  N (Tens.)  
 $BF = DF = 400$  N (Comp.)  
 $FC = 400$  N (Tens.)]

6. A plane truss is loaded and supported as shown in Fig. 11.45. Determine the nature and magnitude of forces in the members 1, 2 and 3.

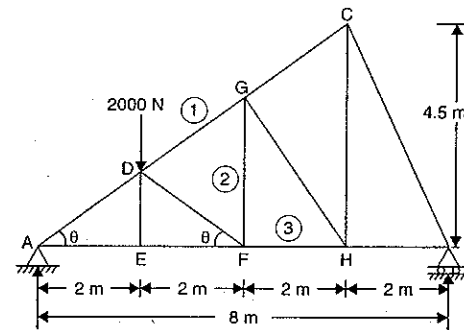

Fig. 11.45

- [Ans.  $F_1 = 833.34$  N (Comp.)  
 $F_2 = 1000$  N (Tens.)  
 $F_3 = 666.66$  N (Tens.)]

7. Determine the forces in all the members of a cantilever truss shown in Fig. 11.46.

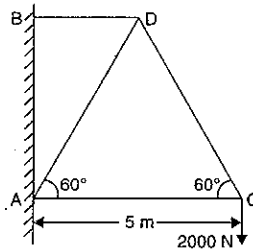

Fig. 11.46

[Ans. AC = 1154.7 N (Comp.)  
 CD = 2309.4 N (Tens.)  
 AD = 2309.4 N (Comp.)  
 BD = 2309.4 N (Tens.)]

8. A cantilever truss is loaded as shown in Fig. 11.47. Find the force in member AB.

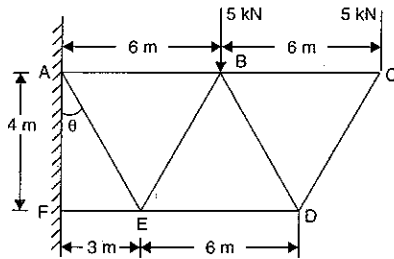

Fig. 11.47

[Ans. AB = 15 kN (Tens.)]

9. Find the axial forces in all the members of the truss shown in Fig. 11.48.

[Hint. Start from joint B  
 First find angles  $\theta$  and  $\alpha$

$$\tan \theta = \frac{ED}{EB} = \frac{3}{6} = \frac{1}{2} \therefore \theta = \tan^{-1} 0.5 = 26.56^\circ$$

$$\tan \alpha = \frac{EA}{ED} = \frac{3}{3} = 1 \therefore \alpha = \tan^{-1} 1.0 = 45^\circ$$

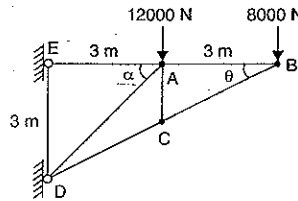
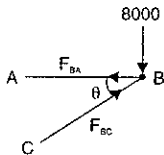

Fig. 11.48

Joint B



$$\Sigma F_y = 0, F_{BC} \sin \theta = 8000$$

$$\therefore F_{BC} = \frac{8000}{\sin \theta} = \frac{8000}{\sin 26.56^\circ} = 17891 \text{ N (Comp.)}$$

$$\Sigma F_x = 0 = F_{BC} \cos \theta$$

$$= 17891 \times \cos 26.56^\circ = 16002 \text{ N (Tensile)}$$

Joint C

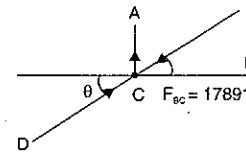

$$\Sigma F_x = 0, F_{BC} \cos \theta = F_{CD} \cos \theta$$

$$\therefore F_{CD} = F_{BC} = 17891 \text{ N (Comp.)}$$

$$\Sigma F_y = 0, F_{CA} - F_{BC} \sin \theta + F_{CD} \sin \theta = 0$$

$$\therefore F_{CA} = 0 \quad (\because F_{BC} = F_{CD})$$

Joint A

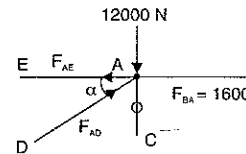

$$\Sigma F_y = 0, F_{AD} \cos \alpha = 12000$$

$$\therefore F_{AD} = \frac{12000}{\sin 45^\circ} = 16970$$

$$\Sigma F_x = 0, F_{AD} \cos \alpha - F_{AE} + F_{BA} = 0$$

$$\text{or } F_{AD} \cos 45^\circ - F_{AE} + 16002 = 0$$

$$16970 \cos 45^\circ - F_{AE} + 16002 = 0$$

$$\therefore F_{AE} = 16002 + 16970 \cos 45^\circ$$

$$= 16002 + 11999 = 28001 \text{ N (Tens.)}$$

10. Determine the forces in the truss shown in Fig. 11.49 which carries a horizontal load of 16 kN and a vertical load of 24 kN.

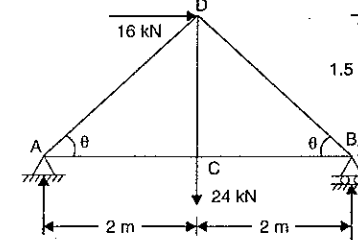

Fig. 11.49

[Ans. AC = 24 kN (Tens.)  
 AD = 10 kN (Comp.)  
 CD = 24 kN (Tens.)  
 CB = 24 kN (Tens.)  
 BD = 30 kN (Comp.)]

11. Find the forces in the member AB and AC of the truss shown in Fig. 11.40 of question 1, using method of sections.

[Ans. AB = 4.33 kN (Comp.)  
 AC = 2.5 kN (Comp.)]

12. Find the forces in the members marked 1, 3, 5 of truss shown in Fig. 11.41 of question 2, using method of sections.

[Ans.  $F_1 = 333 \text{ N (Comp.)}$   
 $F_3 = 577.5 \text{ N (Tens.)}$   
 $F_5 = 577.5 \text{ N (Tens.)}$ ]

13. Find the forces in the members DE, CE and CB of the truss, shown in Fig. 11.42 of question 3, using method of sections.

[Ans. DE = 3.5 kN (Comp.)  
 CE = 2.598 kN (Comp.)  
 BC = 4.33 kN (Tens.)]

14. Using method of section, determine the forces in the members CD, FD and FE of the truss shown in Fig. 11.43 of question 5.

[Ans. CD = 800 N (Comp.)  
 FD = 400 N (Comp.)  
 FE = 600 N (Tens.)]

15. Using method of section, determine the forces in the members  $CD$ ,  $ED$  and  $EF$  of the truss shown in Fig. 11.50.

[Ans.  $CD = 4.216$  kN (Comp.)  
 $ED = 3.155$  kN (Tens.)  
 $EF = 2.58$  kN (Tens.)]

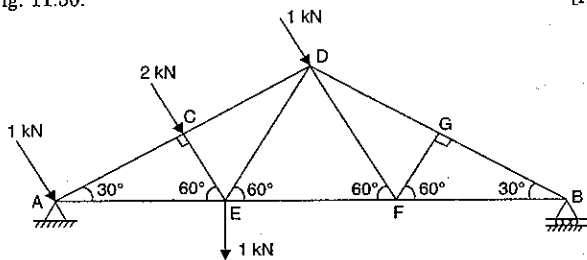

Fig. 11.50

16. Find the forces in the members  $AB$ ,  $AC$  and  $BC$  of the truss shown in Fig. 11.40 of question 1, using graphical method.
17. Using graphical method, determine the magnitude and nature of the forces in the members of the truss shown in Fig. 11.41 of question 2.
18. Determine the forces in all the members of a cantilever truss shown in Fig. 11.46 of question 7, using graphical method. Also determine the sections of the cantilever.
19. A cantilever truss is loaded and supported as shown in Fig. 11.51. Find the value of load  $P$  which would produce an axial force of magnitude 3 kN in the member  $AC$  using method of section.

(U.P. Tech. University, 2002-2003)

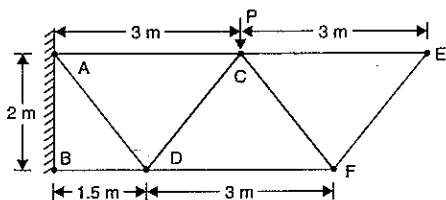

Fig. 11.51

[Hint. Force in member  $AC$ ,  $F_{AC} = 3$  kN  
 Now pass a section ①-① as shown in Fig. 11.51 (a).

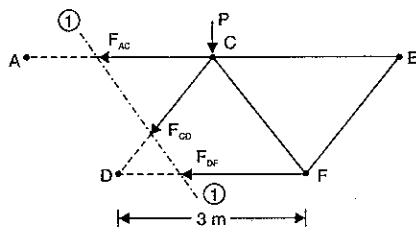

Fig. 11.51 (a)

Take moments about point  $D$ .

$$\sum M_D = 0; F_{AC} \times 2 - P \times 1.5 = 0 \quad \text{But} \quad F_{AC} = 3 \text{ kN}$$

$$\therefore 3 \times 2 - P \times 1.5 = 0$$

$$\text{or} \quad 6 = 1.5P \text{ or } P = 4 \text{ kN. Ans.}]$$

# 12

## Deflection of Beams

### 12.1. INTRODUCTION

If a beam carries uniformly distributed load or a point load, the beam is deflected from its original position. In this chapter, we shall study the amount by which a beam is deflected from its position. Due to the loads acting on the beam, it will be subjected to bending moment. The radius of curvature of the deflected beam is given by the equation  $\frac{M}{I} = \frac{E}{R}$ . The ra-

dius of curvature will be constant if  $R = \frac{I \times E}{M} = \text{constant}$ .

The term  $(I \times E)/M$  will be constant, if the beam is subjected to a constant bending moment  $M$ . This means that a beam for which, when loaded, the value of  $(E \times I)/M$  is constant, will bend in a circular arc.

Fig. 12.1 (a) shows the beam position before any load is applied on the beam whereas Fig. 12.1 (b) shows the beam position after loading.

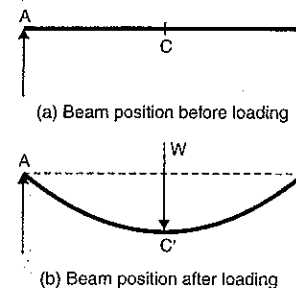

Fig. 12.1

### 12.2. DEFLECTION AND SLOPE OF A BEAM SUBJECTED TO UNIFORM BENDING MOMENT

A beam  $AB$  of length  $L$  is subjected to a uniform bending moment  $M$  as shown in Fig. 12.1 (c). As the beam is subjected to a constant bending moment, hence it will bend into a circular arc. The initial position of the beam is shown by  $ACB$ , whereas the deflected position is shown by  $A'C'B'$ .

Let  $R$  = Radius of curvature of the deflected beam,  
 $y$  = Deflection of the beam at the centre (i.e., distance  $CC'$ ),

$I$  = Moment of inertia of the beam section,

$E$  = Young's modulus for the beam material, and

$\theta$  = Slope of the beam at the end  $A$  (i.e., the angle made by the tangent at  $A$  with the beam  $AB$ ).

For a practical beam the deflection  $y$  is a small quantity.

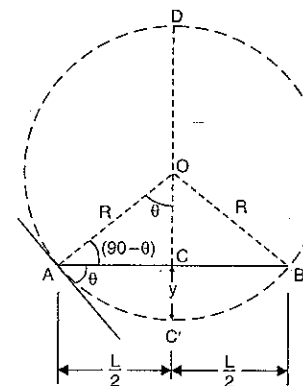

Fig. 12.1 (c)

Hence  $\tan \theta = \theta$  where  $\theta$  is in radians. Hence  $\theta$  becomes the slope as slope is

$$\frac{dy}{dx} = \tan \theta = \theta.$$

Now  $AC = BC = \frac{L}{2}$

Also from the geometry of a circle, we know that

$$AC \times CB = DC \times CC'$$

$$\frac{L}{2} \times \frac{L}{2} = (2R - y) \times y \quad (\because DC = DC' - CC' = 2R - y)$$

$$\frac{L^2}{4} = 2Ry - y^2$$

For a practical beam, the deflection  $y$  is a small quantity. Hence the square of a small quantity will be negligible. Hence neglecting  $y^2$  in the above equation, we get

$$\frac{L^2}{4} = 2Ry$$

$$\therefore y = \frac{L^2}{8R} \quad \dots(i)$$

But from bending equation, we have

$$\frac{M}{I} = \frac{E}{R}$$

$$R = \frac{E \times I}{M} \quad \dots(ii)$$

Substituting the value of  $R$  in equation (i), we get

$$y = \frac{L^2}{8 \times \frac{EI}{M}}$$

$$y = \frac{ML^2}{8EI} \quad \dots(12.1)$$

The equation (12.1) gives the central deflection of a beam which bends in a circular arc.

*Value of Slope ( $\theta$ )*

From triangle  $AOB$ , we know that

$$\sin \theta = \frac{AC}{AO} = \frac{\left(\frac{L}{2}\right)}{R} = \frac{L}{2R}$$

Since the angle  $\theta$  is very small, hence  $\sin \theta = \theta$  (in radians)

$$\begin{aligned} \therefore \theta &= \frac{L}{2R} \\ &= \frac{L}{2 \times \frac{EI}{M}} \quad \left(\because R = \frac{EI}{M} \text{ from equation (ii)}\right) \\ &= \frac{M \times L}{2EI} \end{aligned} \quad \dots(12.2)$$

Equation (12.2) gives the slope of the deflected beam at  $A$  or at  $B$ .

### 12.3. RELATION BETWEEN SLOPE, DEFLECTION AND RADIUS OF CURVATURE

Let the curve  $AB$  represents the deflection of a beam as shown in Fig. 12.2 (a). Consider a small portion  $PQ$  of this beam. Let the tangents at  $P$  and  $Q$  make angle  $\psi$  and  $\psi + d\psi$  with  $x$ -axis. Normal at  $P$  and  $Q$  will meet at  $C$  such that

$$PC = QC = R$$

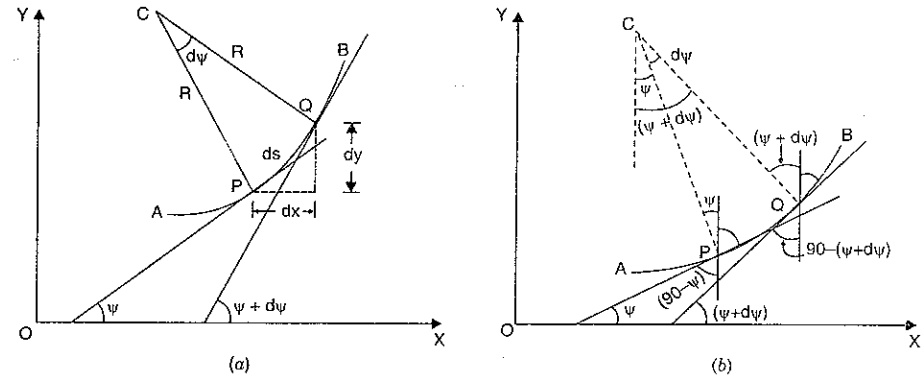

Fig. 12.2

The point  $C$  is known as centre of curvature of the curve  $PQ$ .

Let the length of  $PQ$  is equal to  $ds$ .

From Fig. 12.2 (b), we see that

$$\text{Angle } PCQ = d\psi$$

$$\therefore PQ = ds = R \cdot d\psi$$

$$\text{or } R = \frac{ds}{d\psi} \quad \dots(i)$$

But if  $x$  and  $y$  be the co-ordinates of  $P$ , then

$$\tan \psi = \frac{dy}{dx} \quad \dots(ii)$$

$$\sin \psi = \frac{dy}{ds}$$

$$\text{and } \cos \psi = \frac{dx}{ds}$$

Now equation (i) can be written as

$$R = \frac{ds}{d\psi} = \frac{\left(\frac{ds}{dx}\right)}{\left(\frac{d\psi}{dx}\right)} = \frac{\left(\frac{1}{\cos \psi}\right)}{\left(\frac{d\psi}{dx}\right)}$$

$$\text{or } R = \frac{\sec \psi}{\left(\frac{d\psi}{dx}\right)} \quad \dots(iii)$$



Differentiating equation (ii) w.r.t.  $x$ , we get

$$\sec^2 \psi \cdot \frac{d\psi}{dx} = \frac{d^2 y}{dx^2}$$

or

$$\frac{d\psi}{dx} = \frac{\left(\frac{d^2 y}{dx^2}\right)}{\sec^2 \psi}$$

Substituting this value of  $\frac{d\psi}{dx}$  in equation (iii), we get

$$R = \frac{\sec \psi}{\left(\frac{\frac{d^2 y}{dx^2}}{\sec^2 \psi}\right)} = \frac{\sec \psi \cdot \sec^2 \psi}{\frac{d^2 y}{dx^2}} = \frac{\sec^3 \psi}{\left(\frac{d^2 y}{dx^2}\right)}$$

Taking the reciprocal to both sides, we get

$$\frac{1}{R} = \frac{\frac{d^2 y}{dx^2}}{\sec^3 \psi} = \frac{\frac{d^2 y}{dx^2}}{(\sec^2 \psi)^{3/2}}$$

$$= \frac{\frac{d^2 y}{dx^2}}{(1 + \tan^2 \psi)^{3/2}}$$

For a practical beam, the slope  $\tan \psi$  at any point is a small quantity. Hence  $\tan^2 \psi$  can be neglected.

$$\therefore \frac{1}{R} = \frac{d^2 y}{dx^2} \quad \dots(iv)$$

From the bending equation, we have

$$\frac{M}{I} = \frac{E}{R}$$

$$\frac{1}{R} = \frac{M}{EI} \quad \dots(v)$$

or

Equating equations (iv) and (v), we get

$$\frac{M}{EI} = \frac{d^2 y}{dx^2}$$

$$\therefore M = EI \frac{d^2 y}{dx^2} \quad \dots(12.3)$$

Differentiating the above equation w.r.t.  $x$ , we get

$$\frac{dM}{dx} = EI \frac{d^3 y}{dx^3}$$

But

$$\frac{dM}{dx} = F \text{ shear force (See page 288)}$$

$$\therefore F = EI \frac{d^3 y}{dx^3} \quad \dots(12.4)$$

Differentiating equation (12.4) w.r.t.  $x$ , we get

$$\frac{dF}{dx} = EI \frac{d^4 y}{dx^4}$$

But

$$\frac{dF}{dx} = w \text{ the rate of loading}$$

$$\therefore w = EI \frac{d^4 y}{dx^4} \quad \dots(12.5)$$

Hence, the relation between curvature, slope, deflection etc. at a section is given by :

$$\text{Deflection} = y$$

$$\text{Slope} = \frac{dy}{dx}$$

$$\text{Bending moment} = EI \frac{d^2 y}{dx^2}$$

$$\text{Shearing force} = EI \frac{d^3 y}{dx^3}$$

$$\text{The rate of loading} = EI \frac{d^4 y}{dx^4}$$

**Units.** In the above equations,  $E$  is taken in  $\text{N/mm}^2$

$I$  is taken in  $\text{mm}^4$ ,  $y$  is taken in  $\text{mm}$ ,

$M$  is taken in  $\text{Nm}$  and  $x$  is taken in  $\text{m}$ .

**12.3.1. Methods of Determining Slope and Deflection at a Section in a Loaded Beam.** The followings are the important methods for finding the slope and deflection at a section in a loaded beam :

(i) Double integration method

(ii) Moment area method, and

(iii) Macaulay's method

In case of double integration method, the equation used is

$$M = EI \frac{d^2 y}{dx^2} \quad \text{or} \quad \frac{d^2 y}{dx^2} = \frac{M}{EI}$$

First integration of the above equation gives the value of  $\frac{dy}{dx}$  or slope. The second integration gives the value of  $y$  or deflection.

The first two methods are used for a single load whereas the third method is used for several loads.

#### 12.4. DEFLECTION OF A SIMPLY SUPPORTED BEAM CARRYING A POINT LOAD AT THE CENTRE

A simply supported beam  $AB$  of length  $L$  and carrying a point load  $W$  at the centre is shown in Fig. 12.3.

As the load is symmetrically applied the reactions  $R_A$  and  $R_B$  will be equal. Also the maximum deflection will be at the centre.

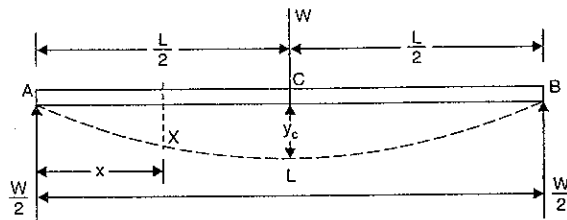

Fig. 12.3

Now  $R_A = R_B = \frac{W}{2}$

Consider a section X at a distance  $x$  from A. The bending moment at this section is given by,

$$M_x = R_A \times x = \frac{W}{2} \times x \quad \text{(Plus sign is as B.M. for left portion at X is clockwise)}$$

But B.M. at any section is also given by equation (12.3) as

$$M = EI \frac{d^2 y}{dx^2}$$

Equating the two values of B.M., we get

$$EI \frac{d^2 y}{dx^2} = \frac{W}{2} \times x \quad \dots(i)$$

On integration, we get

$$EI \frac{dy}{dx} = \frac{W}{2} \times \frac{x^2}{2} + C_1 \quad \dots(ii)$$

where  $C_1$  is the constant of integration. And its value is obtained from boundary conditions.

The boundary condition is that at  $x = \frac{L}{2}$ , slope  $\left(\frac{dy}{dx}\right) = 0$  (As the maximum deflection is at the centre, hence slope at the centre will be zero). Substituting this boundary condition in equation (ii), we get

$$0 = \frac{W}{4} \times \left(\frac{L}{2}\right)^2 + C_1$$

or

$$C_1 = -\frac{WL^2}{16}$$

Substituting the value of  $C_1$  in equation (ii), we get

$$EI \frac{dy}{dx} = \frac{Wx^2}{4} - \frac{WL^2}{16} \quad \dots(iii)$$

The above equation is known the *slope equation*. We can find the slope at any point on the beam by substituting the values of  $x$ . Slope is maximum at A. At A,  $x = 0$  and hence slope at A will be obtained by substituting  $x = 0$  in equation (iii).

$$\therefore EI \left(\frac{dy}{dx}\right)_{\text{at A}} = \frac{W}{4} \times 0 - \frac{WL^2}{16}$$

$\left[\left(\frac{dy}{dx}\right)_{\text{at A}} \text{ is the slope at A and is represented by } \theta_A\right]$

or  $EI \times \theta_A = -\frac{WL^2}{16}$

$$\therefore \theta_A = -\frac{WL^2}{16EI}$$

The slope at point B will be equal to  $\theta_A$ , since the load is symmetrically applied.

$$\therefore \theta_B = \theta_A = -\frac{WL^2}{16EI} \quad \dots(12.6)$$

Equation (12.6) gives the slope in radians.

*Deflection at any point*

Deflection at any point is obtained by integrating the slope equation (iii). Hence integrating equation (iii), we get

$$EI \times y = \frac{W}{4} \cdot \frac{x^3}{3} - \frac{WL^2}{16} x + C_2 \quad \dots(iv)$$

where  $C_2$  is another constant of integration. At A,  $x = 0$  and the deflection ( $y$ ) is zero.

Hence substituting these values in equation (iv), we get

$$EI \times 0 = 0 - 0 + C_2$$

or

$$C_2 = 0$$

Substituting the value of  $C_2$  in equation (iv), we get

$$EI \times y = \frac{Wx^3}{12} - \frac{WL^2 \cdot x}{16} \quad \dots(v)$$

The above equation is known as the *deflection equation*. We can find the deflection at any point on the beam by substituting the values of  $x$ . The deflection is maximum at centre point C, where  $x = \frac{L}{2}$ . Let  $y_c$  represents the deflection at C. Then substituting  $x = \frac{L}{2}$  and  $y = y_c$  in equation (v), we get

$$\begin{aligned} EI \times y_c &= \frac{W}{12} \left(\frac{L}{2}\right)^3 - \frac{WL^2}{16} \times \left(\frac{L}{2}\right) \\ &= \frac{WL^3}{96} - \frac{WL^3}{32} = \frac{WL^3 - 3WL^3}{96} \\ &= -\frac{2WL^3}{96} = -\frac{WL^3}{48} \end{aligned}$$

$$\therefore y_c = -\frac{WL^3}{48EI}$$

(Negative sign shows that deflection is downwards)

$$\therefore \text{Downward deflection, } y_c = \frac{WL^3}{48EI} \quad \dots(12.7)$$

**Problem 12.1.** A beam 6 m long, simply supported at its ends, is carrying a point load of 50 kN at its centre. The moment of inertia of the beam (i.e.  $I$ ) is given as equal to  $78 \times 10^6 \text{ mm}^4$ . If  $E$  for the material of the beam =  $2.1 \times 10^5 \text{ N/mm}^2$ , calculate : (i) deflection at the centre of the beam and (ii) slope at the supports.

**Sol. Given :**

Length,  $L = 6 \text{ m} = 6 \times 1000 = 6000 \text{ mm}$

Point load,  $W = 50 \text{ kN} = 50,000 \text{ N}$

M.O.I.,  $I = 78 \times 10^6 \text{ mm}^4$

Value of  $E = 2.1 \times 10^5 \text{ N/mm}^2$

Let  $y_c =$  Deflection at the centre and

$\theta_A =$  Slope at the support.

(i) Using equation (12.7) for the deflection at the centre, we get

$$\begin{aligned} y_c &= \frac{WL^3}{48EI} \\ &= \frac{50000 \times 6000^3}{48 \times 2.1 \times 10^5 \times 78 \times 10^6} \\ &= 13.736 \text{ mm. Ans.} \end{aligned}$$

(ii) Using equation (12.6) for the slope at the supports, we get

$$\begin{aligned} \theta_B = \theta_A &= -\frac{WL^2}{16EI} \\ &= \frac{WL^2}{16EI} \quad \text{(Numerically)} \\ &= \frac{50000 \times 6000^2}{16 \times 2.1 \times 10^5 \times 78 \times 10^6} \text{ radians} \\ &= 0.06868 \text{ radians} \\ &= 0.06868 \times \frac{180}{\pi} \text{ degree} \quad \left( \because 1 \text{ radian} = \frac{180}{\pi} \text{ degree} \right) \\ &= 3.935^\circ. \text{ Ans.} \end{aligned}$$

**Problem 12.2.** A beam 4 metre long, simply supported at its ends, carries a point load  $W$  at its centre. If the slope at the ends of the beam is not to exceed  $1^\circ$ , find the deflection at the centre of the beam.

**Sol. Given :**

Length,  $L = 4 \text{ m} = 4000 \text{ mm}$

Point load at centre =  $W$

Slope at the ends,  $\theta_A = \theta_B = 1^\circ = \frac{1 \times \pi}{180} = 0.01745 \text{ radians}$

Let  $y_c =$  Deflection at the centre

Using equation (12.6), for the slope at the supports, we get

$$\begin{aligned} \theta_A &= \frac{WL^2}{16EI} \quad \text{(Numerically)} \\ \text{or } 0.01745 &= \frac{WL^2}{16EI} \quad \dots(i) \end{aligned}$$

Now using equation (12.7), we get

$$\begin{aligned} y_c &= \frac{WL^3}{48EI} \\ &= \frac{WL^2}{16EI} \times \frac{L}{3} \quad \left( \because \frac{WL^3}{48EI} = \frac{WL^2}{16EI} \times \frac{L}{3} \right) \\ &= 0.01745 \times \frac{4000}{3} \quad \left[ \because \frac{WL^2}{16EI} = 0.01745 \text{ from equation (i)} \right] \\ &= 23.26 \text{ mm. Ans.} \end{aligned}$$

**Problem 12.3.** A beam 3 m long, simply supported at its ends, is carrying a point load  $W$  at the centre. If the slope at the ends of the beam should not exceed  $1^\circ$ , find the deflection at the centre of the beam. (Annamalai University, 1991)

**Sol. Given :**

Length,  $L = 3 \text{ m} = 3 \times 1000 = 3000 \text{ mm}$

Point load at centre =  $W$

Slope at the ends,  $\theta_A = \theta_B = 1^\circ$

$$= \frac{1 \times \pi}{180} = 0.01745 \text{ radians}$$

Let  $y_c =$  Deflection at the centre

Using equation (12.6), we get

$$\theta_A = \frac{WL^2}{16EI} \quad \text{or} \quad 0.01745 = \frac{WL^2}{16EI} \quad \dots(i)$$

Now using equation (12.7), we get

$$\begin{aligned} y_c &= \frac{WL^3}{48EI} = \frac{WL^2}{16EI} \times \frac{L}{3} \\ &= 0.01745 \times \frac{L}{3} \quad \left( \because \frac{WL^2}{16EI} = 0.01745 \right) \\ &= 0.01745 \times \frac{3000}{3} \quad (\because L = 3000 \text{ mm}) \\ &= 17.45 \text{ mm. Ans.} \end{aligned}$$

## 12.5. DEFLECTION OF A SIMPLY SUPPORTED BEAM WITH AN ECCENTRIC POINT LOAD

A simply supported beam  $AB$  of length  $L$  and carrying a point load  $W$  at a distance  $a$  from support  $A$  and at a distance  $b$  from support  $B$  is shown in Fig. 12.4.

The reactions at  $A$  and  $B$  can be calculated by taking moments about  $A$ .

We find that reaction at  $A$  is given by

$$R_A = \frac{W \times b}{L} \quad \text{and} \quad R_B = \frac{W \times a}{L}$$

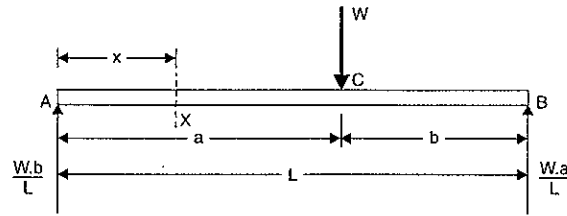

Fig. 12.4

(a) Now consider a section X at a distance  $x$  from A in length AC. The bending moment at this section is given by,

$$M_x = R_A \times x \\ = \frac{W \times b}{L} \times x \quad \text{(Plus sign due to sagging)}$$

But B.M. at any section is also given by equation (12.3) as

$$M = EI \frac{d^2 y}{dx^2}$$

Equating the two values of B.M., we get

$$EI = \frac{d^2 y}{dx^2} = \frac{W \times b}{L} \times x$$

Integrating the above equation, we get

$$EI \frac{dy}{dx} = \frac{W \times b}{L} \times \frac{x^2}{2} + C_1 \quad \dots(i)$$

where  $C_1$  is the constant of integration.

Integrating the equation (i), we get

$$EI \cdot y = \frac{W \cdot b}{2L} \cdot \frac{x^3}{3} + C_1 \cdot x + C_2 \quad \dots(ii)$$

where  $C_2$  is another constant of integration. The values of  $C_1$  and  $C_2$  are obtained from boundary conditions.

(i) At A,  $x = 0$  and deflection  $y = 0$

Substituting these values in equation (ii), we get

$$0 = 0 + 0 + C_2$$

$\therefore C_2 = 0$

Substituting the value of  $C_2$  in equation (ii), we get

$$EI \cdot y = \frac{W \cdot b}{6L} \cdot x^3 + C_1 \cdot x \quad \dots(iii)$$

(ii) At C,  $x = a$  and slope  $\frac{dy}{dx} = \theta_C$ . (Note that value of  $\theta_C$  is unknown).

The value of  $C_1$  is obtained by substituting these values in equation (i). Hence, we get

$$EI \cdot \theta_C = \frac{W \cdot b}{L} \cdot \frac{a^2}{2} + C_1$$

$$C_1 = EI \times \theta_C - \frac{W \cdot b \cdot a^2}{2L}$$

Substituting the value of  $C_1$  in equations (i) and (iii), we get

$$EI \frac{dy}{dx} = \frac{W \cdot b}{2L} \cdot x^2 + EI \times \theta_C - \frac{W \cdot b \cdot a^2}{2L} \quad \dots(iv)$$

$$EI y = \frac{W \cdot b}{6L} \cdot x^3 + \left( EI \cdot \theta_C - \frac{W \cdot b \cdot a^2}{2L} \right) x \quad \dots(v)$$

The equation (iv) gives the slope whereas equation (v) gives the deflection at any point in section AC. But the value of  $\theta_C$  is unknown.

(b) Now consider a section X at a distance  $x$  from A in length CB as shown in Fig. 12.5. Here  $x$  varies from  $a$  to  $L$ . The B.M. at this section is given by,

$$M_x = R_A \cdot x - W(x - a) \\ = \frac{W \cdot b}{L} \cdot x - W(x - a)$$

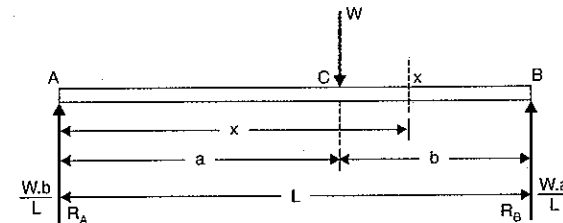

Fig. 12.5

But B.M. at this section is also given by equation (12.3) as

$$M = EI \frac{d^2 y}{dx^2}$$

Equating the two values of B.M., we get

$$EI \frac{d^2 y}{dx^2} = \frac{W \cdot b}{L} \cdot x - W(x - a)$$

Integrating the above equation, we get

$$EI \frac{dy}{dx} = \frac{W \cdot b}{L} \cdot \frac{x^2}{2} - \frac{W(x - a)^2}{2} + C_3 \quad \dots(vi)$$

where  $C_3$  is the constant of integration.

Integrating the equation (vi) again, we get

$$EI \cdot y = \frac{W \cdot b}{2L} \cdot \frac{x^3}{3} - \frac{W}{2} \cdot \frac{(x - a)^3}{3} + C_3 x + C_4 \quad \dots(vii)$$

where  $C_4$  is another constant of integration. The values of  $C_3$  and  $C_4$  are obtained from boundary conditions.

(i) At B,  $x = L$  and  $y = 0$ . Substituting these values in equation (vii), we get

$$0 = \frac{W \cdot b}{2L} \cdot \frac{L^3}{3} - \frac{W}{2} \cdot \frac{(L - a)^3}{3} + C_3 \times L + C_4$$

$$= \frac{W \cdot b \cdot L^2}{6} - \frac{W \cdot b^3}{6} + C_3 L + C_4 \quad (\because L - a = b)$$

$$\therefore C_4 = \frac{Wb^3}{6} - \frac{W \cdot b \cdot L^2}{6} - C_3 \times L \quad \dots(viii)$$

(ii) At  $C$ ,  $x = a$  and slope  $\frac{dy}{dx} = \theta_C$ . (The value of  $\theta_C$  is unknown).

The value of  $C_3$  is obtained by substituting these values in equation (vi).

Hence, we get from equation (vi)

$$EI \cdot \theta_C = \frac{W \cdot b \cdot a^2}{2L} - \frac{W}{2} (a - a)^2 + C_3$$

$$= \frac{W \cdot b \cdot a^2}{2L} - 0 + C_3$$

$$\therefore C_3 = EI \cdot \theta_C - \frac{W \cdot b \cdot a^2}{2L} \quad \dots(ix)$$

Substituting the value of  $C_3$  in equation (viii), we get

$$C_4 = \frac{W \cdot b^3}{6} - \frac{W \cdot b \cdot L^2}{6} - \left( EI \cdot \theta_C - \frac{W \cdot b \cdot a^2}{2L} \right) L$$

$$= \frac{W \cdot b^3}{6} - \frac{W \cdot b \cdot L^2}{6} - EI \cdot \theta_C \cdot L + \frac{W \cdot b \cdot a^2}{2}$$

$$= \frac{W \cdot b}{6} (b^2 - L^2) - EI \cdot \theta_C \cdot L + \frac{W \cdot b \cdot a^2}{2}$$

$$= \frac{W \cdot b}{6} (b^2 - L^2) + \frac{W \cdot b \cdot a^2}{2} - EIL \cdot \theta_C$$

$$= \frac{W \cdot b}{6} [b^2 - L^2 + 3a^2] - EIL \cdot \theta_C$$

$$= \frac{W \cdot b}{6} [b^2 - (a + b)^2 + 3a^2] - EIL \cdot \theta_C \quad (\because L = a + b)$$

$$= \frac{W \cdot b}{6} [b^2 - a^2 - b^2 - 2ab + 3a^2] - EIL \cdot \theta_C$$

$$= \frac{W \cdot b}{6} [2a^2 - 2ab] - EIL \cdot \theta_C$$

$$= \frac{W \cdot b}{6} \times 2a(a - b) - EIL \cdot \theta_C$$

$$= \frac{W \cdot ab}{3} [a - b] - EIL \cdot \theta_C$$

The slope (i.e.,  $\frac{dy}{dx}$ ) at any point in  $CB$  is obtained by substituting the value of  $C_3$  in equation (vi). Hence, we get from equation (vi),

$$EI \frac{dy}{dx} = \frac{W \cdot b}{2L} \cdot x^2 - \frac{W}{2} (x - a)^2 + EI \cdot \theta_C - \frac{W \cdot b \cdot a^2}{2L} \quad \dots(x)$$

The deflection (i.e.,  $y$ ) at any point in  $CB$  is obtained by substituting the values of  $C_3$  and  $C_4$  in equation (vii). Hence, we get from equation (vii),

$$EI \cdot \frac{W \cdot b}{6L} \cdot x^3 - \frac{W}{6} (x - a)^3 + \left( EI \cdot \theta_C - \frac{W \cdot b \cdot a^2}{2L} \right) x$$

$$+ \frac{W \cdot ab}{3} (a - b) - EI \cdot L \cdot \theta_C \quad \dots(xi)$$

The deflection at the point  $C$  is obtained by substituting  $x = a$  in the above equation. Let  $y_C =$  the deflection at  $C$ . Hence, we get

$$EI \cdot y_C = \frac{W \cdot b \cdot a^3}{6L} - \frac{W}{6} (a - a)^3 + \left( EI \cdot \theta_C - \frac{W \cdot b \cdot a^2}{2L} \right) a$$

$$+ \frac{W \cdot a \cdot b}{3} (a - b) - EIL \cdot \theta_C$$

$$\text{or } y_C = \frac{1}{EI} \left[ \frac{W \cdot b \cdot a^3}{6L} - 0 + EI \cdot a \cdot \theta_C - \frac{W \cdot b \cdot a^3}{2L} + \frac{W \cdot a \cdot b}{3} (a - b) - EI \cdot L \cdot \theta_C \right]$$

$$= \frac{1}{EI} \left[ \frac{W \cdot b \cdot a^3}{6L} - \frac{W \cdot a \cdot b^3}{2L} + \frac{W \cdot a \cdot b}{3} (a - b) + EI \cdot a \cdot \theta_C - EIL \cdot \theta_C \right] \quad \dots(A)$$

The deflection at the point  $C$  can also be obtained by substituting  $x = a$  in equation (v). Hence, we get

$$EI \cdot y_C = \frac{W \cdot b \cdot a^3}{6L} + \left( EI \cdot \theta_C - \frac{W \cdot b \cdot a^2}{2L} \right) \cdot a$$

$$\text{or } y_C = \frac{1}{EI} \left[ \frac{W \cdot b \cdot a^3}{6L} + EI \cdot \theta_C \cdot a - \frac{W \cdot b \cdot a^3}{2L} \right] \quad \dots(B)$$

Equating the two values of  $y_C$  given by equations (A) and (B), we get

$$\frac{1}{EI} \left[ \frac{W \cdot b \cdot a^3}{6L} + EI \cdot \theta_C \cdot a - \frac{W \cdot b \cdot a^3}{2L} \right] = \frac{1}{EI} \left[ \frac{W \cdot b \cdot a^3}{6L} - \frac{W \cdot b \cdot a^3}{2L} + \frac{W \cdot a \cdot b}{3} (a - b) \right.$$

$$\left. + EI \cdot a \cdot \theta_C - EI \cdot L \cdot \theta_C \right]$$

$$\text{or } 0 = \frac{W \cdot a \cdot b}{3} (a - b) - EIL \cdot \theta_C$$

$$\text{or } EIL \cdot \theta_C = \frac{W \cdot a \cdot b}{3} (a - b)$$

$$\text{or } \theta_C = \frac{W \cdot a \cdot b}{3EI \cdot L} (a - b) \quad \dots(12.8)$$

The above equation gives the value of  $\theta_C$  (i.e., slope at point  $C$ ). Substituting this value of  $\theta_C$  in equation (iv), we get the slope at any point in  $AC$ . Hence, we get from equation (iv),

$$EI \frac{dy}{dx} = \frac{W \cdot b}{2L} \cdot x^2 + EI \times \frac{W \cdot a \cdot b}{3EI \cdot L} (a - b) - \frac{W \cdot b \cdot a^2}{2L}$$

$$= \frac{W \cdot b}{2L} \cdot x^2 + \frac{W \cdot a \cdot b}{3L} (a - b) - \frac{W \cdot b \cdot a^2}{2L}$$

$$\begin{aligned}
 &= \frac{W \cdot b}{6L} [3x^2 + 2a(a-b) - 3a^2] \\
 &= \frac{W \cdot b}{6L} [3x^2 - 2ab - a^2] \quad \dots(C)
 \end{aligned}$$

As the length  $AC$  is more than length  $CB$ , hence maximum slope will be at the support

$A$ , where  $x = 0$ . Let the slope at  $A$  is represented by  $\theta_A$ . Hence  $\frac{dy}{dx}$  at  $A$  will be equal to  $\theta_A$ .

Substituting  $x = 0$  in equation (C), we get

$$EI \left( \frac{dy}{dx} \right)_{\text{at } A} = \frac{W \cdot b}{6L} [3 \times 0 - 2ab - a^2]$$

$$\text{or } EI \theta_A = \frac{W \cdot b}{6L} (-2ab - a^2)$$

$$\text{or } \theta_A = \frac{-W \cdot a \cdot b}{6EI \cdot L} (a + 2b) \quad \dots(12.9)$$

[Negative sign with the slope means that tangent at the point  $A$  makes an angle in the anti-clockwise or negative direction].

#### Value of Maximum Deflection

Since ' $a$ ' is more than ' $b$ ' hence maximum deflection will be in length  $AC$ . The deflection at any point in length  $AC$  is given by equation (v) as

$$\begin{aligned}
 EI \cdot y &= \frac{W \cdot b}{6L} x^3 + \left( EI \cdot \theta_C - \frac{W \cdot b \cdot a^2}{2L} \right) x \\
 &= \frac{W \cdot b}{6L} x^3 + \left[ EI \cdot \frac{W \cdot a \cdot b}{3EI \cdot L} (a-b) - \frac{W \cdot b \cdot a^2}{2L} \right] \cdot x \\
 &\quad \left[ \because \theta_C = \frac{W \cdot a \cdot b}{3EI \cdot L} (a-b) \text{ from Eq. (12.8)} \right]
 \end{aligned}$$

$$= \frac{W \cdot b}{6L} x^3 + \left[ \frac{W \cdot a \cdot b}{3L} (a-b) - \frac{W \cdot b \cdot a^2}{2L} \right] \cdot x$$

$$= \frac{W \cdot b}{6L} [x^3 + 2a(a-b)x - 3a^2 \cdot x]$$

$$= \frac{W \cdot b}{6L} [x^3 + 2a^2x - 2abx - 3a^2x]$$

$$= \frac{W \cdot b}{6L} [x^3 - a^2x - 2abx] = \frac{W \cdot b}{6L} [x^3 - x(a^2 + 2ab)]$$

$$y = \frac{W \cdot b}{6EIL} [x^3 - x(a^2 + 2ab)] \quad \dots(D)$$

The deflection will be maximum if  $\frac{dy}{dx} = 0$

$$\text{But } \frac{dy}{dx} = \frac{W \cdot b}{6EIL} [3x^2 - (a^2 + 2ab)]$$

For maximum deflection,  $\frac{dy}{dx} = 0$

$$\therefore \frac{W \cdot b}{6EIL} [3x^2 - (a^2 + 2ab)] = 0$$

$$\text{or } 3x^2 - (a^2 + 2ab) = 0$$

$$\left( \because \frac{W \cdot b}{6EIL} \text{ cannot be zero} \right)$$

$$\text{or } x^2 = \frac{a^2 + 2ab}{3}$$

$$x = \left[ \frac{a^2 + 2ab}{3} \right]^{1/2}$$

Substituting this value of  $x$  in equation (D), we get maximum deflection.

$$\begin{aligned}
 \therefore y_{\max} &= \frac{W \cdot b}{6EIL} \left[ \left( \frac{a^2 + 2ab}{3} \right)^{3/2} - \left( \frac{a^2 + 2ab}{3} \right)^{1/2} (a^2 + 2ab) \right] \\
 &= \frac{W \cdot b}{6EIL} \left[ \frac{(a^2 + 2ab)^{3/2}}{3 \times \sqrt{3}} - \frac{(a^2 + 2ab)^{3/2}}{\sqrt{3}} \right] \\
 &= \frac{W \cdot b}{6EIL} \cdot (a^2 + 2ab)^{3/2} \left[ \frac{1}{3 \times \sqrt{3}} - \frac{1}{\sqrt{3}} \right] \\
 &= \frac{W \cdot b}{6EIL} (a^2 + 2ab)^{3/2} \frac{(1-3)}{3\sqrt{3}} \\
 &= - \frac{W \cdot b}{9\sqrt{3}EI \cdot L} (a^2 + 2ab)^{3/2}
 \end{aligned}$$

Negative sign means the deflection is in downward direction.

$$\therefore \text{Downward, } y_{\max} = \frac{W \cdot b}{9\sqrt{3}EI \cdot L} (a^2 + 2ab)^{3/2} \quad \dots(12.10)$$

#### Deflection under the point load

Let  $y_C$  = Deflection under the point load

The deflection at any point in length  $AC$  is given by equation (D), as

$$y_C = \frac{W \cdot b}{6EIL} [x^3 - x(a^2 + 2ab)]$$

The deflection under the point load will be obtained by substituting  $x = a$  in the above equation.

$$\begin{aligned}
 \therefore y_C &= \frac{W \cdot b}{6EIL} [a^3 - a(a^2 + 2ab)] \\
 &= \frac{W \cdot b}{6EIL} [a^3 - a^3 - 2a^2b] \\
 &= \frac{W \cdot b}{6EIL} \times (-2a^2b) = - \frac{Wa^2b^2}{3EIL}
 \end{aligned}$$

Negative sign means the deflection is downward.

$$\therefore \text{Downward, } y_C = \frac{Wa^2b^2}{3EIL} \quad \dots(12.11)$$

**Note.** The above method for finding the slope and deflection is very laborious. There is a simple method of finding the slope and deflection at any point in a beam. This method is known as **Macaulay's method** which will be discussed later on.

**Problem 12.4.** Determine : (i) slope at the left support, (ii) deflection under the load and (iii) maximum deflection of a simply supported beam of length 5 m, which is carrying a point load of 5 kN at a distance of 3 m from the left end. Take  $E = 2 \times 10^5 \text{ N/mm}^2$  and  $I = 1 \times 10^8 \text{ mm}^4$ .

**Sol. Given :**

Length,  $L = 5 \text{ m} = 5000 \text{ mm}$

Point load,  $W = 5 \text{ kN} = 5000 \text{ N}$

Distance between point load and left end,

$$a = 3 \text{ m} = 3000 \text{ mm}$$

$$\therefore b = L - a = 5 - 3 = 2 \text{ m} = 2000 \text{ mm}$$

Value of  $E = 2 \times 10^5 \text{ N/mm}^2$

M.O.I.,  $I = 1 \times 10^8 \text{ mm}^4$

Let  $\theta_A =$  Slope at the left support,

$y_C =$  Deflection under the load, and

$y_{max} =$  Maximum deflection.

(i) Using equation (12.9), we get

$$\begin{aligned} \theta_A &= -\frac{W \cdot a \cdot b}{6EI \cdot L} (a + 2b) \\ &= -\frac{5000 \times 3000 \times 2000}{6 \times 2 \times 10^5 \times 10^8 \times 5000} \times (3000 + 2 \times 2000) \quad (\text{radians}) \\ &= -0.00035 \text{ radians. Ans.} \end{aligned}$$

Negative sign means that the angle made by tangent at A is anti-clockwise.

(ii) The deflection under the load is given by equation (12.11), as

$$\begin{aligned} y_C &= \frac{Wa^2 \cdot b^2}{3EIL} \\ &= \frac{5000 \times 3000^2 \times 2000^2}{3 \times 2 \times 10^5 \times 10^8 \times 5000} = 0.6 \text{ mm. Ans.} \end{aligned}$$

(iii) The maximum deflection is given by equation (12.10), as

$$\begin{aligned} y_{max} &= \frac{W \cdot b}{9\sqrt{3} EI \cdot L} (a^2 + 2ab)^{3/2} \\ &= \frac{5000 \times 2000}{9 \times \sqrt{3} \times 2 \times 10^5 \times 10^8 \times 5000} (3000^2 + 2 \times 3000 \times 2000)^{3/2} \\ &= \frac{1}{9 \times \sqrt{3} \times 10^{10}} (9000000 + 12000000)^{3/2} \\ &= 0.6173 \text{ mm. Ans.} \end{aligned}$$

## 12.6. DEFLECTION OF A SIMPLY SUPPORTED BEAM WITH A UNIFORMLY DISTRIBUTED LOAD

A simply supported beam AB of length  $L$  and carrying a uniformly distributed load of  $w$  per unit length over the entire length is shown in Fig. 12.6. The reactions at A and B will be equal. Also the maximum deflection will be at the centre. Each vertical reaction =  $\frac{w \times L}{2}$ .

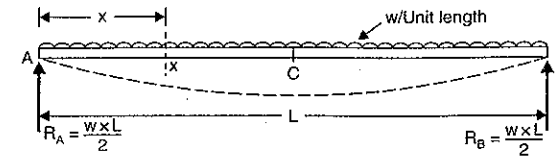

Fig. 12.6

$$\therefore R_A = R_B = \frac{w \times L}{2}$$

Consider a section X at a distance  $x$  from A. The bending moment at this section is given by,

$$M_x = R_A \times x - w \times x \times \frac{x}{2} = \frac{w \cdot L}{2} \cdot x - \frac{w \cdot x^2}{2}$$

But B.M. at any section is also given by equation (12.3), as

$$M = EI \frac{d^2 y}{dx^2}$$

Equating the two values of B.M., we get

$$EI \frac{d^2 y}{dx^2} = \frac{w \cdot L}{2} x - \frac{w \cdot x^2}{2}$$

Integrating the above equation, we get

$$EI \frac{dy}{dx} = \frac{w \cdot L}{2} \cdot \frac{x^2}{2} - \frac{w}{2} \cdot \frac{x^3}{3} + C_1 \quad \dots(i)$$

where  $C_1$  is a constant of integration.

Integrating the above equation again, we get

$$EI \cdot y = \frac{w \cdot L}{4} \cdot \frac{x^3}{3} - \frac{w}{6} \cdot \frac{x^4}{4} + C_1 x + C_2 \quad \dots(ii)$$

where  $C_2$  is another constant of integration. Thus two constants of integration (i.e.,  $C_1$  and  $C_2$ ) are obtained from boundary conditions. The boundary conditions are :

(i) at  $x = 0, y = 0$  and (ii) at  $x = L, y = 0$

Substituting first boundary condition i.e.,  $x = 0, y = 0$  in equation (ii), we get

$$0 = 0 - 0 + 0 + C_2 \quad \text{or} \quad C_2 = 0$$

Substituting the second boundary condition i.e., at  $x = L, y = 0$  in equation (ii), we get

$$0 = \frac{w \cdot L}{4} \cdot \frac{L^3}{3} - \frac{w}{6} \cdot \frac{L^4}{4} + C_1 \cdot L \quad (C_2 \text{ is already zero})$$

$$= \frac{w \cdot L^4}{12} - \frac{w \cdot L^4}{24} + C_1 \cdot L$$

$$C_1 = -\frac{wL^3}{12} + \frac{wL^3}{24} = -\frac{wL^3}{24}$$

or

Substituting the value of  $C_1$  in equations (i) and (ii), we get

$$EI \frac{dy}{dx} = \frac{w \cdot L}{4} \cdot x^2 - \frac{w}{6} x^3 - \frac{wL^3}{24} \quad \dots(iii)$$

and 
$$EIy = \frac{w \cdot L}{12} x^3 - \frac{w}{24} \cdot x^4 + \left( -\frac{wL^3}{24} \right) x + 0 \quad (\because C_2 = 0)$$

or 
$$EIy = \frac{w \cdot L}{12} x^3 - \frac{w}{24} \cdot x^4 - \frac{wL^3}{24} x \quad \dots(iv)$$

The equation (iii) is known as *slope equation*. We can find the slope (i.e., the value of  $\frac{dy}{dx}$ )

at any point on the beam by substituting the different values of  $x$  in this equation.

The equation (iv) is known as *deflection equation*. We can find the deflection (i.e., the value of  $y$ ) at any point on the beam by substituting the different values of  $x$  in this equation.

*Slope at the supports*

Let  $\theta_A =$  Slope at support A. This is equal to  $\left( \frac{dy}{dx} \right)_{at A}$

and  $\theta_B =$  Slope at support B =  $\left( \frac{dy}{dx} \right)_{at B}$

At A,  $x = 0$  and  $\frac{dy}{dx} = \theta_A$ .

Substituting these values in equation (iii), we get

$$\begin{aligned} EI\theta_A &= \frac{wL}{4} \times 0 - \frac{w}{6} \times 0 - \frac{wL^3}{24} \\ &= \frac{wL^3}{24} = -\frac{WL^2}{24} \quad (\because w \cdot L = W = \text{Total load}) \end{aligned}$$

$$\therefore \theta_A = -\frac{WL^2}{24EI} \quad \dots(12.12)$$

(Negative sign means that tangent at A makes an angle with AB in the anti-clockwise direction)

By symmetry,  $\theta_B = -\frac{WL^2}{24EI} \quad \dots(12.13)$

*Maximum Deflection*

The maximum deflection is at the centre of the beam i.e., at point C, where  $x = \frac{L}{2}$ . Let  $y_C$

= deflection at C which is also maximum deflection. Substituting  $y = y_C$  and  $x = \frac{L}{2}$  in the

equation (iv), we get

$$\begin{aligned} EIy_C &= \frac{w \cdot L}{12} \cdot \left( \frac{L}{2} \right)^3 - \frac{w}{24} \cdot \left( \frac{L}{2} \right)^4 - \frac{wL^3}{24} \cdot \left( \frac{L}{2} \right) \\ &= \frac{w \cdot L^4}{96} - \frac{wL^4}{384} - \frac{wL^4}{48} = -\frac{5wL^4}{384} \end{aligned}$$

$$\therefore y_C = -\frac{5}{384} \cdot \frac{wL^4}{EI} = -\frac{5}{384} \cdot \frac{W \cdot L^3}{EI} \quad (\because w \cdot L = W = \text{Total load})$$

Negative sign indicates that deflection is downwards.

$\therefore$  Downward deflection,

$$y_C = \frac{5}{384} \cdot \frac{WL^3}{EI} \quad \dots(12.14)$$

**Problem 12.5.** A beam of uniform rectangular section 200 mm wide and 300 mm deep is simply supported at its ends. It carries a uniformly distributed load of 9 kN/m run over the entire span of 5 m. If the value of  $E$  for the beam material is  $1 \times 10^4$  N/mm<sup>2</sup>, find :

- (i) the slope at the supports and (ii) maximum deflection.

**Sol.** Given :

Width,  $b = 200$  mm

Depth,  $d = 300$  mm

M.O.I.,  $I = \frac{bd^3}{12} = \frac{200 \times 300^3}{12} = 4.5 \times 10^8$  mm<sup>4</sup>

U.d.l.,  $w = 9$  kN/m = 9000 N/m

Span,  $L = 5$  m = 5000 mm

$\therefore$  Total load,  $W = w \cdot L = 9000 \times 5 = 45000$  N

Value of  $E = 1 \times 10^4$  N/mm<sup>2</sup>

Let  $\theta_A =$  Slope at the support

and  $y_C =$  Maximum deflection.

(i) Using equation (12.12), we get

$$\begin{aligned} \theta_A &= -\frac{W \cdot L^2}{24EI} \\ &= -\frac{45000 \times 5000^2}{24 \times 1 \times 10^4 \times 4.5 \times 10^8} \text{ radians} \\ &= \mathbf{0.0104 \text{ radians. Ans.}} \end{aligned}$$

(ii) Using equation (12.14), we get

$$\begin{aligned} y_C &= \frac{5}{384} \cdot \frac{W \cdot L^3}{EI} \\ &= \frac{5}{384} \times \frac{45000 \times 5000^3}{1 \times 10^4 \times 4.5 \times 10^8} \\ &= \mathbf{16.27 \text{ mm. Ans.}} \end{aligned}$$

**Problem 12.6.** A beam of length 5 m and of uniform rectangular section is simply supported at its ends. It carries a uniformly distributed load of 9 kN/m run over the entire length. Calculate the width and depth of the beam if permissible bending stress is 7 N/mm<sup>2</sup> and central deflection is not to exceed 1 cm.

Take  $E$  for beam material =  $1 \times 10^4$  N/mm<sup>2</sup>.

**Sol.** Given :

Length,  $L = 5$  m = 5000 mm

U.d.l.,  $w = 9$  kN/m

\*Here  $L$  should be taken in metre. Hence for calculating total load,  $L$  must be in metre and in other calculations  $L$  is taken in mm.



$\therefore$  Total load,  $W = w.L = 9 \times 5 = 45 \text{ kN} = 45000 \text{ N}$   
 Bending stress,  $f = 7 \text{ N/mm}^2$   
 Central deflection,  $y_C = 1 \text{ cm} = 10 \text{ mm}$   
 Value of  $E = 1 \times 10^4 \text{ N/mm}^2$   
 Let  $b =$  Width of beam in mm  
 and  $d =$  Depth of beam in mm

$\therefore$  M.O.I.,  $I = \frac{bd^3}{12}$   
 Using equation (12.14), we get

$$y_C = \frac{5}{384} \cdot \frac{W \cdot L^3}{EI}$$

$$\text{or } 10 = \frac{5}{384} \times \frac{45000 \times 5000^3}{1 \times 10^4 \times \left(\frac{bd^3}{12}\right)}$$

$$\text{or } bd^3 = \frac{5}{384} \times \frac{45000 \times 5000^3 \times 12}{1 \times 10^4 \times 10} = 878.906 \times 10^7 \text{ mm}^4 \quad \dots(i)$$

The maximum bending moment for a simply supported beam carrying a uniformly distributed load is given by,

$$\begin{aligned}
 M &= \frac{w \cdot L^2}{8} = \frac{W \cdot L}{8} & (\because W = w.L = \text{Total load}) \\
 &= \frac{45000 \times 5}{8} \text{ Nm} = \frac{45000 \times 5}{8} \times 1000 \text{ Nmm} \\
 &= 28125000 \text{ Nmm}
 \end{aligned}$$

Now using the bending equation as

$$\frac{M}{I} = \frac{f}{y}$$

$$\text{or } \frac{28125000}{\left(\frac{bd^3}{12}\right)} = \frac{7}{\left(\frac{d}{2}\right)} \quad (\because \text{Here } y = \frac{d}{2})$$

$$\text{or } \frac{28125000 \times 12}{bd^3} = \frac{14}{d}$$

$$\text{or } bd^2 = \frac{28125000 \times 12}{14} = 24107142.85 \text{ mm}^3 \quad \dots(ii)$$

Dividing equation (i) by equation (ii), we get

$$d = \frac{878.906 \times 10^7}{24107142.85} = 364.58 \text{ mm. Ans.}$$

Substituting this value of 'd' in equation (ii), we get

$$b \times (364.58)^2 = 24107142.85$$

$$\therefore b = \frac{24107142.85}{364.58^2} = 181.36 \text{ mm. Ans.}$$

**Problem 12.7.** A beam of length 5 m and of uniform rectangular section is supported at its ends and carries uniformly distributed load over the entire length. Calculate the depth of the section if the maximum permissible bending stress is  $8 \text{ N/mm}^2$  and central deflection is not to exceed 10 mm.

Take the value of  $E = 1.2 \times 10^4 \text{ N/mm}^2$ .

**Sol.** Given :

Length,  $L = 5 \text{ m} = 5000 \text{ mm}$

Bending stress,  $f = 8 \text{ N/mm}^2$

Central deflection,  $y_C = 10 \text{ mm}$

Value of  $E = 1.2 \times 10^4 \text{ N/mm}^2$

Let  $W =$  Total load

and  $d =$  Depth of beam

The maximum bending moment for a simply supported beam carrying a uniformly distributed load is given by,

$$M = \frac{w \cdot L^2}{8} = \frac{W \cdot L}{8} \quad (\because W = w.L) \quad \dots(i)$$

Now using the bending equation,

$$\frac{M}{I} = \frac{f}{y}$$

$$\text{or } M = \frac{f \times I}{y} = \frac{8 \times I}{(d/2)} \quad (\because y = \frac{d}{2})$$

$$\therefore M = \frac{16I}{d} \quad \dots(ii)$$

Equating the two values of B.M., we get

$$\frac{W \cdot L}{8} = \frac{16I}{d}$$

$$\text{or } W = \frac{16 \times 8I}{L \times d} = \frac{128I}{L \times d} \quad \dots(iii)$$

Now using equation (12.14), we get

$$y_C = \frac{5}{384} \times \frac{WL^3}{EI}$$

$$\text{or } 10 = \frac{5}{384} \times \frac{128I}{L \times d} \times \frac{L^3}{EI} \quad (\because y_C = 10 \text{ mm and } W = \frac{128I}{L \times d})$$

$$= \frac{5}{384} \times \frac{128 \times L^2}{d \times E}$$

$$\text{or } d = \frac{5}{384} \times \frac{128 \times L^2}{10 \times E} = \frac{5}{384} \times \frac{128 \times 5000^2}{10 \times 1.2 \times 10^4} = 347.2 \text{ mm} = 34.72 \text{ cm. Ans.}$$

## 12.7. MACAULAY'S METHOD

The procedure of finding slope and deflection for a simply supported beam with an eccentric point load as mentioned in Art. 12.5, is a very laborious. There is a convenient method for determining the deflections of the beam subjected to point loads.

This method was devised by Mr. M.H. Macaulay and is known as Macaulay's method. This method mainly consists in the special manner in which the bending moment at any section is expressed and in the manner in which the integrations are carried out.

**12.7.1. Deflection of a Simply Supported Beam with an Eccentric Point Load.** A simply supported beam AB of length L and carrying a point load W at a distance 'a' from left support and at a distance 'b' from right support is shown in Fig. 12.7. The reactions at A and B are given by,

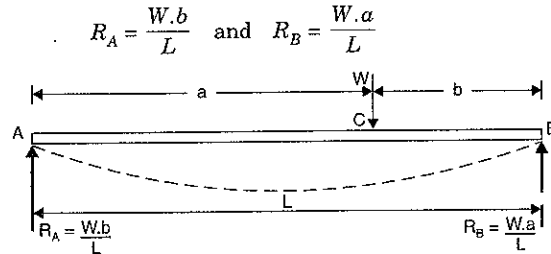

Fig. 12.7

The bending moment at any section between A and C at a distance x from A is given by,

$$M_x = R_A \times x = \frac{W \cdot b}{L} \times x$$

The above equation of B.M. holds good for the values of x between 0 and 'a'. The B.M. at any section between C and B at a distance x from A is given by,

$$M_x = R_A \cdot x - W \times (x - a) = \frac{W \cdot b}{L} \cdot x - W(x - a)$$

The above equation of B.M. holds good for all values of x between x = a and x = b.

The B.M. for all sections of the beam can be expressed in a single equation written as

$$M_x = \frac{W \cdot b}{L} x \dots - W(x - a) \dots (i)$$

Stop at the dotted line for any point in section AC. But for any point in section CB, add the expression beyond the dotted line also.

The B.M. at any section is also given by equation (12.3) as

$$M = EI \frac{d^2 y}{dx^2} \dots (ii)$$

Hence equating (i) and (ii), we get

$$EI \frac{d^2 y}{dx^2} = \frac{W \cdot b}{L} \cdot x \dots - W(x - a) \dots (iii)$$

Integrating the above equation, we get

$$EI \frac{dy}{dx} = \frac{W \cdot b}{L} \frac{x^2}{2} + C_1 \dots - \frac{W(x - a)^2}{2} \dots (iv)$$

where  $C_1$  is a constant of integration. This constant of integration should be written after the first term. Also the brackets are to be integrated as a whole. Hence the integration of  $(x - a)$  will be  $\frac{(x - a)^2}{2}$  and not  $\frac{x^2}{2} - ax$ .

Integrating equation (iv) once again, we get

$$EIy = \frac{W \cdot b}{2L} \cdot \frac{x^3}{3} + C_1 x + C_2 \dots - \frac{W(x - a)^3}{6} \dots (v)$$

where  $C_2$  is another constant of integration. This constant is written after  $C_1 x$ . The integration of  $(x - a)^2$  will be  $\left(\frac{x - a}{3}\right)^3$ . This type of integration is justified as the constant of integrations  $C_1$  and  $C_2$  are valid for all values of x.

The values of  $C_1$  and  $C_2$  are obtained from boundary conditions. The two boundary conditions are :

(i) At  $x = 0, y = 0$  and (ii) At  $x = L, y = 0$

(i) At A,  $x = 0$  and  $y = 0$ . Substituting these values in equation (v) upto dotted line only, we get

$$0 = 0 + 0 + C_2$$

$$\therefore C_2 = 0$$

(ii) At B,  $x = L$  and  $y = 0$ . Substituting these values in equation (v), we get

$$0 = \frac{W \cdot b}{2L} \cdot \frac{L^3}{3} + C_1 \times L + 0 - \frac{W(L - a)^3}{6} \dots (\because C_2 = 0. \text{ Here complete Eq. (v) is to be taken})$$

$$= \frac{W \cdot b \cdot L^2}{6} + C_1 \times L - \frac{W \cdot b^3}{6} \dots (\because L - a = b)$$

$$\therefore C_1 \times L = \frac{W}{6} \cdot b^3 - \frac{W \cdot b \cdot L^2}{6} = -\frac{W \cdot b}{6} (L^2 - b^2)$$

$$\therefore C_1 = -\frac{W \cdot b}{6L} (L^2 - b^2) \dots (vi)$$

Substituting the value of  $C_1$  in equation (iv), we get

$$EI \frac{dy}{dx} = \frac{W \cdot b}{L} \frac{x^2}{2} + \left[ -\frac{W \cdot b}{6L} (L^2 - b^2) \right] \dots - \frac{W(x - a)^2}{2} \dots (vii)$$

The equation (vii) gives the slope at any point in the beam. Slope is maximum at A or B. To find the slope at A, substitute  $x = 0$  in the above equation upto dotted line as point A lies in AC.

$$\therefore EI \theta_A = \frac{W \cdot b}{2L} \times 0 - \frac{Wb}{6L} (L^2 - b^2) \dots \left( \because \frac{dy}{dx} \text{ at } A = \theta_A \right)$$

$$= -\frac{Wb}{6L} (L^2 - b^2)$$

$$\therefore \theta_A = -\frac{Wb}{6EI} (L^2 - b^2) \dots (\text{as given before})$$

Substituting the values of  $C_1$  and  $C_2$  in equation (v), we get

$$EIy = \frac{W \cdot b}{6L} \cdot x^3 + \left[ -\frac{Wb}{6L} (L^2 - b^2) \right] x + 0 \quad \dots (viii)$$

The equation (viii) gives the deflection at any point in the beam. To find the deflection  $y_c$  under the load, substitute  $x = a$  in equation (viii) and consider the equation upto dotted line (as point C lies in AC). Hence, we get

$$\begin{aligned} EIy_c &= \frac{W \cdot b}{6L} \cdot a^3 - \frac{W \cdot b}{6L} (L^2 - b^2)a = \frac{W \cdot b}{6L} \cdot a (a^2 - L^2 + b^2) \\ &= -\frac{W \cdot a \cdot b}{6L} (L^2 - a^2 - b^2) \\ &= -\frac{W \cdot a \cdot b}{6L} \{ (a+b)^2 - a^2 - b^2 \} \quad (\because L = a+b) \\ &= -\frac{W \cdot a \cdot b}{6L} [a^2 + b^2 + 2ab - a^2 - b^2] \\ &= -\frac{W \cdot a \cdot b}{6L} [2ab] = -\frac{Wa^2 \cdot b^2}{3L} \\ \therefore y_c &= -\frac{Wa^2 \cdot b^2}{3EIL} \quad \dots (\text{same as before}) \end{aligned}$$

**Note.** While using Macaulay's Method, the section  $x$  is to be taken in the last portion of the beam.

**Problem 12.8.** A beam of length 6 m is simply supported at its ends and carries a point load of 40 kN at a distance of 4 m from the left support. Find the deflection under the load and maximum deflection. Also calculate the point at which maximum deflection takes place. Given M.O.I. of beam =  $7.33 \times 10^7 \text{ mm}^4$  and  $E = 2 \times 10^5 \text{ N/mm}^2$ .

**Sol. Given :**

Length,  $L = 6 \text{ m} = 6000 \text{ mm}$

Point load,  $W = 40 \text{ kN} = 40,000 \text{ N}$

Distance of point load from left support,  $a = 4 \text{ m} = 4000 \text{ mm}$

$\therefore b = L - a = 6 - 4 = 2 \text{ m} = 2000 \text{ mm}$

Let  $y_c =$  Deflection under the load

$y_{max} =$  Maximum deflection

Using equation  $y_c = -\frac{W \cdot a^2 \cdot b^2}{3EIL}$

$$\begin{aligned} \therefore y_c &= -\frac{40000 \times 4000^2 \times 2000^2}{3 \times 2 \times 10^5 \times 7.33 \times 10^7 \times 6000} \\ &= -9.7 \text{ mm. Ans.} \end{aligned}$$

**Problem 12.9.** A beam of length 6 m is simply supported at its ends and carries two point loads of 48 kN and 40 kN at a distance of 1 m and 3 m respectively from the left support. Find :

(i) deflection under each load,

(ii) maximum deflection, and

(iii) the point at which maximum deflection occurs.

Given  $E = 2 \times 10^5 \text{ N/mm}^2$  and  $I = 85 \times 10^6 \text{ mm}^4$ .

**Sol. Given :**

$$I = 85 \times 10^6 \text{ mm}^4 ; E = 2 \times 10^5 \text{ N/mm}^2$$

First calculate the reactions  $R_A$  and  $R_B$ .

Taking moments about A, we get

$$R_B \times 6 = 48 \times 1 + 40 \times 3 = 168$$

$$\therefore R_B = \frac{168}{6} = 28 \text{ kN}$$

$$\therefore R_A = \text{Total load} - R_B = (48 + 40) - 28 = 60 \text{ kN}$$

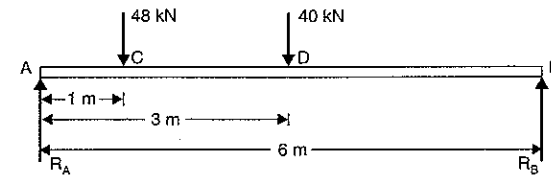

Fig. 12.8

Consider the section X in the last part of the beam (i.e., in length DB) at a distance  $x$  from the left support A. The B.M. at this section is given by,

$$\begin{aligned} EI \frac{d^2y}{dx^2} &= R_A \cdot x \quad \dots - 48(x-1) \quad \dots - 40(x-3) \\ &= 60x \quad \dots - 48(x-1) \quad \dots - 40(x-3) \end{aligned}$$

Integrating the above equation, we get

$$\begin{aligned} EI \frac{dy}{dx} &= \frac{60x^2}{2} + C_1 \quad \dots - 48 \frac{(x-1)^2}{2} \quad \dots - 40 \frac{(x-3)^2}{2} \\ &= 30x^2 + C_1 \quad \dots - 24(x-1)^2 \quad \dots - 20(x-3)^2 \quad \dots (i) \end{aligned}$$

Integrating the above equation again, we get

$$\begin{aligned} EIy &= \frac{30x^3}{3} + C_1x + C_2 \quad \dots - \frac{24(x-1)^3}{3} \quad \dots - \frac{20(x-3)^3}{3} \\ &= 10x^3 + C_1x + C_2 \quad \dots - 8(x-1)^3 \quad \dots - \frac{20}{3}(x-3)^3 \quad \dots (ii) \end{aligned}$$

To find the values of  $C_1$  and  $C_2$ , use two boundary conditions. The boundary conditions are :

(i) at  $x = 0, y = 0$ , and (ii) at  $x = 6 \text{ m}, y = 0$ .

(i) Substituting the first boundary condition i.e., at  $x = 0, y = 0$  in equation (ii) and considering the equation upto first dotted line (as  $x = 0$  lies in the first part of the beam), we get

$$0 = 0 + 0 + C_2 \quad \therefore C_2 = 0$$

(ii) Substituting the second boundary condition i.e., at  $x = 6 \text{ m}, y = 0$  in equation (ii) and considering the complete equation (as  $x = 6$  lies in the last part of the beam), we get

$$0 = 10 \times 6^3 + C_1 \times 6 + 0 - 8(6-1)^3 - \frac{20}{3}(6-3)^3 \quad (\because C_2 = 0)$$

$$\text{or } 0 = 2160 + 6C_1 - 8 \times 5^3 - \frac{20}{3} \times 3^3$$

$$= 2160 + 6C_1 - 1000 - 180 = 980 + 6C_1$$

$$\therefore C_1 = \frac{-980}{6} = -163.33$$

Now substituting the values of  $C_1$  and  $C_2$  in equation (ii), we get

$$EIy = 10x^3 - 163.33x \quad \vdots \quad -8(x-1)^3 \quad \vdots \quad -\frac{20}{3}(x-3)^3 \quad \dots(iii)$$

(i) (a) Deflection under first load i.e., at point C. This is obtained by substituting  $x = 1$  in equation (iii) upto the first dotted line (as the point C lies in the first part of the beam). Hence, we get

$$\begin{aligned} EI.y_c &= 10 \times 1^3 - 163.33 \times 1 \\ &= 10 - 163.33 = -153.33 \text{ kNm}^3 \\ &= -153.33 \times 10^3 \text{ Nm}^3 \\ &= -153.33 \times 10^3 \times 10^9 \text{ Nmm}^3 \\ &= -153.33 \times 10^{12} \text{ Nmm}^3 \end{aligned}$$

$$\therefore y_c = \frac{-153.33 \times 10^{12}}{EI} = \frac{-153.33 \times 10^{12}}{2 \times 10^5 \times 85 \times 10^6} \text{ mm}$$

$$= -9.019 \text{ mm. Ans.}$$

(Negative sign shows that deflection is downwards).

(b) Deflection under second load i.e., at point D. This is obtained by substituting  $x = 3$  m in equation (iii) upto the second dotted line (as the point D lies in the second part of the beam). Hence, we get

$$\begin{aligned} EI.y_D &= 10 \times 3^3 - 163.33 \times 3 - 8(3-1)^3 \\ &= 270 - 489.99 - 64 = -283.99 \text{ kNm}^3 \\ &= -283.99 \times 10^{12} \text{ Nmm}^3 \end{aligned}$$

$$\therefore y_D = \frac{-283.99 \times 10^{12}}{2 \times 10^5 \times 85 \times 10^6} = -16.7 \text{ mm. Ans.}$$

(ii) Maximum Deflection. The deflection is likely to be maximum at a section between C and D. For maximum deflection,  $\frac{dy}{dx}$  should be zero. Hence equate the equation (i) equal to zero upto the second dotted line.

$$\begin{aligned} \therefore 30x^2 + C_1 - 24(x-1)^2 &= 0 \\ \text{or } 30x^2 - 163.33 - 24(x^2 + 1 - 2x) &= 0 & (\because C_1 = -163.33) \\ \text{or } 6x^2 + 48x - 187.33 &= 0 \end{aligned}$$

The above equation is a quadratic equation. Hence its solution is

$$x = \frac{-48 \pm \sqrt{48^2 + 4 \times 6 \times 187.33}}{2 \times 6} = 2.87 \text{ m.}$$

(Neglecting -ve root)

Now substituting  $x = 2.87$  m in equation (iii) upto the second dotted line, we get maximum deflection as

$$\begin{aligned} EI.y_{max} &= 10 \times 2.87^3 - 163.33 \times 2.87 - 8(2.87-1)^3 \\ &= 236.39 - 468.75 - 52.31 \\ &= 284.67 \text{ kNm}^3 = -284.67 \times 10^{12} \text{ Nmm}^3 \end{aligned}$$

$$\therefore y_{max} = \frac{-284.67 \times 10^{12}}{2 \times 10^5 \times 85 \times 10^6} = -16.745 \text{ mm. Ans.}$$

**Problem 12.10.** A beam of length 8 m is simply supported at its ends. It carries a uniformly distributed load of 40 kN/m as shown in Fig. 12.9. Determine the deflection of the beam at its mid-point and also the position of maximum deflection and maximum deflection. Take  $E = 2 \times 10^5 \text{ N/mm}^2$  and  $I = 4.3 \times 10^8 \text{ mm}^4$ .

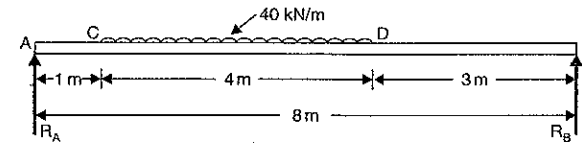

Fig. 12.9

**Sol. Given :**

$$\begin{aligned} \text{Length, } L &= 8 \text{ m} \\ \text{U.d.l., } W &= 40 \text{ kN/m} \\ \text{Value of } E &= 2 \times 10^5 \text{ N/mm}^2 \\ \text{Value of } I &= 4.3 \times 10^8 \text{ mm}^4 \end{aligned}$$

First calculate the reactions  $R_A$  and  $R_B$ .

Taking moments about A, we get

$$R_B \times 8 = 40 \times 4 \times \left(1 + \frac{4}{2}\right) = 480 \text{ kN}$$

$$\therefore R_B = \frac{480}{8} = 60 \text{ kN}$$

$$\therefore R_A = \text{Total load} - R_B = 40 \times 4 - 60 = 100 \text{ kN}$$

In order to obtain the general expression for the bending moment at a distance  $x$  from the left end A, which will apply for all values of  $x$ , it is necessary to extend the uniformly distributed load upto the support B, compensating with an equal upward load of 40 kN/m over the span DB as shown in Fig. 12.10. Now Macaulay's method can be applied.

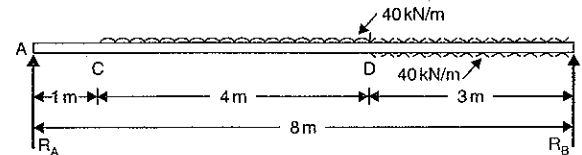

Fig. 12.10

The B.M. at any section at a distance  $x$  from end A is given by,

$$EI \frac{d^2y}{dx^2} = R_A x \quad \vdots \quad -40(x-1) \times \frac{(x-1)}{2} \quad \vdots \quad +40 \times (x-5) \times \frac{(x-5)}{2}$$

$$\text{or } EI \frac{d^2y}{dx^2} = 100x \quad \vdots \quad -20(x-1)^2 \quad \vdots \quad +20(x-5)^2$$

Integrating the above equation, we get

$$EI \frac{dy}{dx} = \frac{100x^2}{2} + C_1 \quad \vdots \quad -\frac{20(x-1)^3}{3} \quad \vdots \quad +20 \frac{(x-5)^3}{3} \quad \dots(i)$$

Integrating again, we get

$$EIy = 50 \frac{x^3}{3} + C_1x + C_2 \quad \vdots \quad -\frac{20}{3} \frac{(x-1)^4}{4} \quad \vdots \quad +\frac{20}{3} \frac{(x-5)^4}{3}$$

$$= 50 \frac{x^3}{3} + C_1x + C_2 \quad \vdots \quad -\frac{5}{3} (x-1)^4 \quad \vdots \quad +\frac{5}{3} (x-5)^4 \quad \dots(ii)$$

where  $C_1$  and  $C_2$  are constants of integration. Their values are obtained from boundary conditions which are:

$$(i) \text{ at } x = 0, y = 0 \quad \text{and} \quad (ii) \text{ at } x = 8 \text{ m}, y = 0$$

(i) Substituting  $x = 0$  and  $y = 0$  in equation (ii) upto first dotted line (as  $x = 0$  lies in the first part AC of the beam), we get

$$0 = 0 + C_1 \times 0 + C_2 \quad \therefore C_2 = 0$$

(ii) Substituting  $x = 8$  and  $y = 0$  in complete equation (ii) (as point  $x = 8$  lies in the last part DB of the beam), we get

$$0 = \frac{50}{3} \times 8^3 + C_1 \times 8 + 0 - \frac{5}{3} (8-1)^4 + \frac{5}{3} (8-5)^4 \quad (\because C_2 = 0)$$

$$= 8533.33 + 8C_1 - 4001.66 + 135$$

$$\text{or} \quad 8C_1 = -4666.67$$

$$\text{or} \quad C_1 = \frac{-4666.67}{8} = -583.33$$

Substituting the value of  $C_1$  and  $C_2$  in equation (ii), we get

$$EIy = \frac{50}{3} x^3 - 583.33x \quad \vdots \quad -\frac{5}{3} (x-1)^4 \quad \vdots \quad +\frac{5}{3} (x-4)^4 \quad \dots(iii)$$

(a) Deflection at the centre

By substituting  $x = 4$  m in equation (iii) upto second dotted line, we get the deflection at the centre. [The point  $x = 4$  lies in the second part (i.e., CD) of the beam].

$$\therefore EIy = \frac{50}{3} \times 4^3 - 583.33 \times 4 - \frac{5}{3} (4-1)^4$$

$$= 1066.66 - 2333.32 - 135 = -1401.66 \text{ kNm}^3$$

$$= -1401.66 \times 1000 \text{ Nm}^3$$

$$= -1401.66 \times 1000 \times 10^9 \text{ Nmm}^3$$

$$= -1401.66 \times 10^{12} \text{ Nmm}^3$$

$$\therefore y = \frac{-1401.66 \times 10^{12}}{EI} = \frac{-1401.66 \times 10^{12}}{2 \times 10^5 \times 4.5 \times 10^8}$$

$$= -16.29 \text{ mm downward. Ans.}$$

(b) Position of maximum deflection

The maximum deflection is likely to lie between C and D. For maximum deflection the slope  $\frac{dy}{dx}$  should be zero. Hence equating the slope given by equation (i) upto second dotted line to zero, we get

$$0 = 100 \frac{x^2}{2} + C_1 - \frac{20}{3} (x-1)^3$$

$$0 = 50x^2 - 583.33 - 6.667(x-1)^3 \quad \dots(iv)$$

The above equation is solved by trial and error method.

Let  $x = 1$ , then R.H.S. of equation (iv)

$$= 50 - 583.33 - 6.667 \times 0 = -533.33$$

$$\text{Let } x = 2, \text{ then R.H.S.} = 50 \times 4 - 583.33 - 6.667 \times 1 = -390.00$$

$$\text{Let } x = 3, \text{ then R.H.S.} = 50 \times 9 - 583.33 - 6.667 \times 8 = -136.69$$

$$\text{Let } x = 4, \text{ then R.H.S.} = 50 \times 16 - 583.33 - 6.667 \times 27 = +36.58$$

In equation (iv), when  $x = 3$  then R.H.S. is negative but when  $x = 4$  then R.H.S. is positive. Hence exact value of  $x$  lies between 3 and 4.

$$\text{Let } x = 3.82, \text{ then R.H.S.} = 50 \times 3.82 - 583.33 - 6.667 (3.82 - 1)^3$$

$$= 729.63 - 583.33 - 149.51 = -3.22$$

$$\text{Let } x = 3.83, \text{ then R.H.S.} = 50 \times 3.83^2 - 583.33 = 6.667 (3.83 - 1)^3$$

$$= 733.445 - 583.33 - 151.1 = -0.99$$

The R.H.S. is approximately zero in comparison to the three terms (i.e., 733.445, 583.33 and 151.1).

$\therefore$  Value of  $x = 3.83$ . Ans.

Hence maximum deflection will be at a distance of 3.83 m from support A.

(c) Maximum deflection

Substituting  $x = 3.83$  m in equation (iii) upto second dotted line, we get the maximum deflection [the point  $x = 3.83$  lies in the second part i.e., CD of the beam.]

$$\therefore EIy_{\max} = \frac{50}{3} \times 3.83^3 - 583.33 \times 3.83 - \frac{5}{3} (3.83 - 1)^4$$

$$= 936.36 - 2234.15 - 106.9 = -1404.69 \text{ kNm}^3$$

$$= -1404.69 \times 10^{12} \text{ Nmm}^3$$

$$\therefore y_{\max} = \frac{-1404.69 \times 10^{12}}{2 \times 10^5 \times 4.3 \times 10^8} = -16.33 \text{ mm. Ans.}$$

**Problem 12.11.** An overhanging beam ABC is loaded as shown in Fig. 12.11. Find the slopes over each support and at the right end. Find also the maximum upward deflection between the supports and the deflection at the right end.

Take  $E = 2 \times 10^5 \text{ N/mm}^2$  and  $I = 5 \times 10^8 \text{ mm}^4$ .

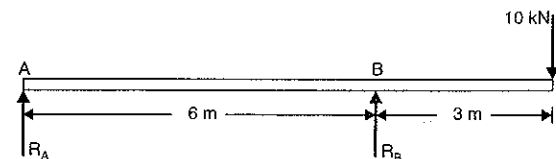

Fig. 12.11

Sol. Given :

$$\text{Point load,} \quad W = 10 \text{ kN}$$

$$\text{Value of} \quad E = 2 \times 10^5 \text{ N/mm}^2$$

$$\text{Value of} \quad I = 5 \times 10^8 \text{ mm}^4$$

First calculate the reaction  $R_A$  and  $R_B$ .

Taking moments about A, we get

$$R_B \times 6 = 10 \times 9$$

$$R_B = \frac{10 \times 9}{6} = 15 \text{ kN}$$

$$R_A = \text{Total load} - R_B = 10 - 15 = -5 \text{ kN}$$

Hence the reaction  $R_A$  will be in the downward direction. Hence Fig. 12.11 will be modified as shown in Fig. 12.12. Now write down an expression for the B.M. in the last section of the beam.

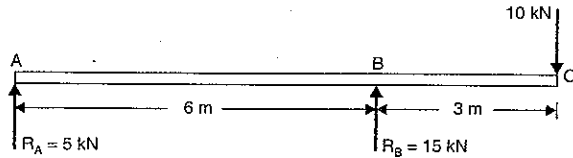

Fig. 12.12

The B.M. at any section at a distance  $x$  from the support A is given by,

$$\begin{aligned} EI \frac{d^2y}{dx^2} &= -R_A \times x \quad \dots + R_B \times (x-6) \\ &= -5x \quad \dots + 15(x-6) \end{aligned} \quad (\because R_A = 5)$$

Integrating the above equation, we get

$$EI \frac{dy}{dx} = \frac{-5x^2}{2} + C_1 \quad \dots + \frac{15(x-6)^2}{2} \quad \dots(i)$$

Integrating again, we get

$$\begin{aligned} EIy &= -\frac{5x^3}{6} + C_1x + C_2 \quad \dots + \frac{15(x-6)^3}{6} \\ &= -\frac{5}{6}x^3 + C_1x + C_2 \quad \dots + \frac{5}{2}(x-6)^3 \end{aligned} \quad \dots(ii)$$

where  $C_1$  and  $C_2$  are constant of integration. Their values are obtained from boundary conditions which are :

$$(i) \text{ at } x = 0, y = 0 \quad \quad \quad (ii) \text{ at } x = 6 \text{ m}, y = 0.$$

(i) Substituting  $x = 0$  and  $y = 0$  in equation (ii) upto dotted line (as  $x = 0$  lies in the first part AB of the beam), we get

$$0 = 0 + C_1 \times 0 + C_2 \quad \therefore C_2 = 0$$

(ii) Substituting  $x = 6$  m and  $y = 0$  in equation (ii) upto dotted line (as  $x = 6$  lies in the first part AB of the beam), we get

$$0 = -\frac{5}{6} \times 6^3 + C_1 \times 6 + 0 \quad (\because C_2 = 0)$$

$$= -5 \times 36 + 6C_1$$

$$C_1 = \frac{+5 \times 36}{6} = 30$$

Substituting the values of  $C_1$  and  $C_2$  in equations (i) and (ii), we get

$$EI \frac{dy}{dx} = -\frac{5}{2}x^2 + 30 \quad \dots + \frac{15}{2}(x-6)^2 \quad \dots(iii)$$

$$EIy = -\frac{5}{6}x^3 + 30x \quad \dots + \frac{5}{2}(x-6)^3 \quad \dots(iv)$$

(a) Slope over the support A

By substituting  $x = 0$  in equation (iii) upto dotted line, we get the slope at support A (the point  $x = 0$  lies in the first part AB of the beam).

$$\begin{aligned} \therefore EI\theta_A &= -\frac{5}{2} \times 0 + 30 = 30 \text{ kNm}^2 = 30 \times 1000 \text{ Nm}^2 \left( \because \frac{dy}{dx} \text{ at } A = \theta_A \right) \\ &= 30 \times 1000 \times 10^6 \text{ Nmm}^2 = 30 \times 10^9 \text{ Nmm}^2 \\ \therefore \theta_A &= \frac{30 \times 10^9}{E \times I} = \frac{30 \times 10^9}{2 \times 10^5 \times 5 \times 10^8} \\ &= 0.0003 \text{ radians. Ans.} \end{aligned}$$

(b) Slope at the support B

By substituting  $x = 6$  m in equation (iii) upto dotted line, we get the slope at support B (the point  $x = 6$  lies in the first part AB of the beam).

$$\begin{aligned} EI\theta_B &= -\frac{5}{2} \times 6^2 + 30 = -90 + 30 \quad \left( \because \frac{dy}{dx} \text{ at } B = \theta_B \right) \\ &= -60 \text{ kNm}^2 = -60 \times 10^9 \text{ Nmm}^2 \\ \therefore \theta_B &= \frac{-60 \times 10^9}{E \times I} = \frac{-60 \times 10^9}{2 \times 10^5 \times 5 \times 10^8} \\ &= -0.0006 \text{ radians. Ans.} \end{aligned}$$

(c) Slope at the right end i.e., at C

By substituting  $x = 9$  m in equation (iii), we get the slope at C. In this case, complete equation is to be taken as point  $x = 9$  m lies in the last part of the beam.

$$\begin{aligned} \therefore EI\theta_C &= -\frac{5}{2} \times 9^2 + 30 + \frac{15}{2}(9-6)^2 \quad \left( \because \frac{dy}{dx} \text{ at } C = \theta_C \right) \\ &= -202.5 + 30 + 67.5 = -105 \text{ kNm}^2 \\ &= -105 \times 10^9 \text{ Nmm}^2 \\ \therefore \theta_C &= \frac{-105 \times 10^9}{E \times I} = \frac{-105 \times 10^9}{2 \times 10^5 \times 5 \times 10^8} \\ &= -0.00105 \text{ radians. Ans.} \end{aligned}$$

(d) Maximum upward deflection between the supports

For maximum deflection between the supports,  $\frac{dy}{dx}$  should be zero. Hence equating the slope given by the equation (iii) to be zero upto dotted line, we get

$$0 = -\frac{5}{2}x^2 + 30 = -5x^2 + 60$$

$$\text{or } 5x^2 = 60 \quad \text{or } x = \sqrt{\frac{60}{5}} = \sqrt{12} = 3.464 \text{ m}$$

Now substituting  $x = 3.464$  m in equation (iv) upto dotted line, we get the maximum deflection as

$$EIy_{max} = -\frac{5}{6} \times 3.464^3 + 30 \times 3.464$$

$$= -34.638 + 103.92 = 69.282 \text{ kNm}^3$$

$$= 69.282 \times 1000 \times 10^9 \text{ Nmm}^3 = 69.282 \times 10^{12} \text{ mm}^3$$

$$y_{max} = \frac{69.282 \times 10^{12}}{2 \times 10^5 \times 5 \times 10^8}$$

$$= 0.6928 \text{ mm (upward). Ans.}$$

(e) Deflection at the right end i.e., at point C

By substituting  $x = 9 \text{ m}$  in equation (iv), we get the deflection at point C. Here complete equation is to be taken as point  $x = 9 \text{ m}$  lies in the last part of the beam.

$$EI y_C = -\frac{5}{6} \times 9^3 + 30 \times 9 + \frac{5}{2} (9 - 6)^3$$

$$= -607.5 + 270 + 67.5$$

$$= -270 \text{ kNm}^3 = -270 \times 10^{12} \text{ Nmm}^3$$

$$y_C = \frac{-270 \times 10^{12}}{2 \times 10^5 \times 5 \times 10^8}$$

$$= -2.7 \text{ mm (downwards). Ans.}$$

**Problem 12.12.** A beam ABC of length 9 m has one support of the left end and the other support at a distance of 6 m from the left end. The beam carries a point load of 12 kN at right end and also carries a uniformly distributed load of 4 kN/m over a length of 3 m as shown in Fig. 12.13. Determine the slope and deflection at point C.

Take  $E = 2 \times 10^5 \text{ N/mm}^2$  and  $I = 5 \times 10^8 \text{ mm}^4$ .

**Sol.** Given :

- Point load,  $W = 12 \text{ kN}$
- U.d.l.,  $w = 4 \text{ kN/m}$
- Value of  $E = 2 \times 10^5 \text{ N/mm}^2$
- Value of  $I = 5 \times 10^8 \text{ mm}^4$

First calculate the reactions  $R_A$  and  $R_B$ .

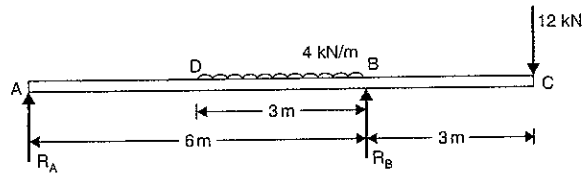

Fig. 12.13

Taking moments about A, we get

$$R_B \times 6 = 4 \times 3 \times \left(3 + \frac{3}{2}\right) + 12 \times 9$$

$$= 54 + 108 = 162$$

$$R_B = \frac{162}{6} = 27 \text{ kN } (\uparrow)$$

and

$$R_A = \text{Total load} - R_B = 24 - 27 = -3 \text{ kN } (\downarrow)$$

Negative sign shows that  $R_A$  will be acting downwards. In order to obtain general expression for the bending moment at a distance  $x$  from the left end A, which will apply for all values of  $x$ , it is necessary to extend the uniformly distributed load upto point C, compensating with an equal upward load of 4 kN/m over the span BC as shown in Fig. 12.14. Now Macaulay's method can be applied.

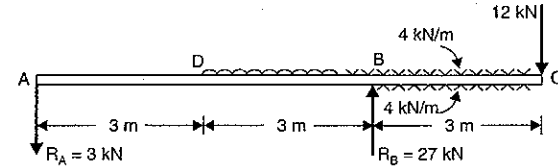

Fig. 12.14

The B.M. at any section at a distance  $x$  from the support A is given by,

$$EI \frac{d^2y}{dx^2} = -R_A \times x \quad \dots -4(x-3) \frac{(x-3)}{2} \quad \dots + R_B(x-6) \quad \dots + 4(x-6) \frac{(x-6)}{2}$$

$$= -3x \quad \dots -2(x-3)^2 \quad \dots + 27(x-6) \quad \dots + 2(x-6)^2$$

Integrating the above equation, we get

$$EI \frac{dy}{dx} = -\frac{3x^2}{2} + C_1 \quad \dots -\frac{2(x-3)^3}{3} \quad \dots + \frac{27(x-6)^2}{2} + \frac{2(x-6)^3}{3} \quad \dots (i)$$

Integrating again, we get

$$EI y = -\frac{3x^3}{2 \cdot 3} + C_1 x + C_2 \quad \dots -\frac{2(x-3)^4}{3 \cdot 4} \quad \dots + \frac{27(x-6)^3}{2 \cdot 3} \quad \dots + \frac{2(x-6)^4}{3 \cdot 4}$$

or

$$EI y = -\frac{x^3}{2} + C_1 x + C_2 \quad \dots -\frac{(x-3)^4}{6} \quad \dots + \frac{9}{2}(x-6)^3 \quad \dots + \frac{1}{6}(x-6)^4 \quad \dots (ii)$$

where  $C_1$  and  $C_2$  are constant of integration. Their values are obtained from boundary conditions which are :

(i) at  $x = 0, y = 0$  and

(ii) at  $x = 6 \text{ m}, y = 0$ .

(i) Substituting the  $x = 0$  and  $y = 0$  in equation (ii) upto first dotted line (as  $x = 0$  lies in the first part AD of the beam), we get

$$0 = 0 + C_1 \times 0 + C_2 \quad \therefore C_2 = 0$$

(ii) Substituting  $x = 6$  and  $y = 0$  in equation (ii) upto second dotted line (as  $x = 6$  lies in the second part DB of the beam), we get

$$0 = -\frac{6^3}{2} + C_1 \times 6 + 0 - \frac{(6-3)^4}{6}$$

$$= -108 + 6C_1 - 13.5 = -121.5 + 6C_1$$

or

$$C_1 = \frac{121.5}{6} = 20.25$$

Substituting the values of  $C_1$  and  $C_2$  in equations (i) and (ii), we get

$$EI \frac{dy}{dx} = -\frac{3}{2}x^2 + 20.25 \quad \dots -\frac{2(x-3)^3}{3} \quad \dots + \frac{27}{2}(x-6)^2 \quad \dots + \frac{2}{3}(x-6)^3 \quad \dots (iii)$$

and

$$EI y = -\frac{x^3}{2} + 20.25 \times x \quad \dots -\frac{1}{6}(x-3)^4 \quad \dots + \frac{9}{2}(x-6)^3 \quad \dots + \frac{1}{6}(x-6)^4 \quad \dots (iv)$$

## (a) Slope at the point C

By substituting  $x = 9$  m in equation (iii), we get the slope at C. Here complete equation is to be taken as point  $x = 9$  m lies in the last part of the beam.

$$EI\theta_C = -\frac{3}{2} \times 9^2 + 20.25 - \frac{2}{3}(9-3)^3 + \frac{27}{2}(9-6)^2 + \frac{1}{3}(9-6)^3$$

$$\left( \because \frac{dy}{dx} \text{ at } C = \theta_C \right)$$

$$= -121.5 + 20.25 - 144 + 121.5 + 18 = -105.75 \text{ kNm}^2$$

$$= -105.75 \times 10^3 \times 10^6 \text{ Nmm}^2 = -105.75 \times 10^9 \text{ Nmm}^2$$

$$\therefore \theta_C = -\frac{105.75 \times 10^9}{2 \times 10^5 \times 5 \times 10^8} = -0.0010575 \text{ radians. Ans.}$$

## (b) Deflection at the point C

By substituting  $x = 9$  m in complete equation (iv), we get the deflection at C.

$$EI \times y_C = -\frac{9^3}{2} + 20.25 \times 9 - \frac{1}{6}(9-3)^4 + \frac{9}{2}(9-6)^3 + \frac{1}{6}(9-6)^4$$

$$= -364.5 + 182.25 - 216 + 121.5 + 13.5$$

$$= -263.25 \text{ kNm}^3 = -263.25 \times 10^{12} \text{ Nmm}^3$$

$$\therefore y_C = -\frac{263.25 \times 10^{12}}{2 \times 10^5 \times 5 \times 10^8} = -2.6325 \text{ mm. Ans.}$$

**Problem 12.13.** A horizontal beam AB is simply supported at A and B, 6 m apart. The beam is subjected to a clockwise couple of 300 kNm at a distance of 4 m from the left end as shown in Fig. 12.15. If  $E = 2 \times 10^5 \text{ N/mm}^2$  and  $I = 2 \times 10^8 \text{ mm}^4$ , determine:

- (i) deflection at the point where couple is acting and  
(ii) the maximum deflection.

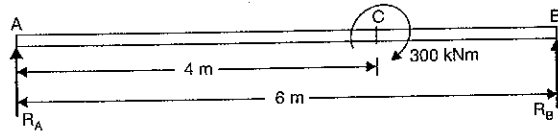

Fig. 12.15

Sol. Given :

Length,	$L = 6$ m
Couple	$= 300$ kNm
Value of	$E = 2 \times 10^5 \text{ N/mm}^2$
Value of	$I = 2 \times 10^8 \text{ mm}^4$

First calculate the reactions  $R_A$  and  $R_B$ .

Taking moments about A, we get

$$R_B \times 6 = 300$$

$$R_B = \frac{300}{6} = 50 \text{ kN } (\uparrow)$$

$$R_A = \text{Total load} - R_B = 0 - 50 \text{ kN } (\because \text{ There is no load on beam})$$

$$= -50 \text{ kN}$$

and

Negative sign shows that  $R_A$  is acting downwards as shown in Fig. 12.16.

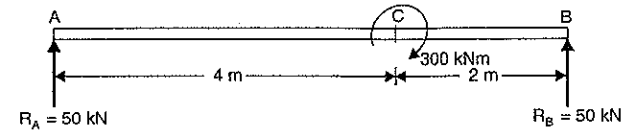

Fig. 12.16

The B.M. at any section at a distance  $x$  from A, is given by

$$EI \frac{d^2y}{dx^2} = -50x \quad \dots + 300$$

$$= -50x \quad \dots + 300(x-4)^0$$

Integrating the above equation, we get

$$EI \frac{dy}{dx} = -\frac{50x^2}{2} + C_1 \quad \dots + 300(x-4) \quad \dots (i)$$

Integrating again, we get

$$EIy = -\frac{50}{2} \times \frac{x^3}{3} + C_1x + C_2 \quad \dots + \frac{300(x-4)^2}{2}$$

$$= -\frac{25}{3}x^3 + C_1x + C_2 \quad \dots + 150(x-4)^2 \quad \dots (ii)$$

where  $C_1$  and  $C_2$  are constants of integration. Their values are obtained from boundary conditions which are :

- (i) at  $x = 0, y = 0$  and (ii) at  $x = 6$  m and  $y = 0$ .  
(i) Substituting  $x = 0$  and  $y = 0$  in equation (ii) upto dotted line, we get

$$0 = 0 + C_1 \times 0 + C_2 \therefore C_2 = 0$$

- (ii) Substituting  $x = 6$  m and  $y = 0$  in complete equation (ii), we get

$$0 = -\frac{25}{3} \times 6^3 + C_1 \times 6 + 0 + 150(6-4)^2$$

$$= -1800 + 6C_1 + 600$$

$$\therefore C_1 = \frac{1800 - 600}{6} = 200$$

Substituting the values of  $C_1$  and  $C_2$  in equation (ii), we get

$$EIy = -\frac{25}{3}x^3 + 200x \quad \dots + 150(x-4)^2 \quad (\because C_2 = 0) \dots (iii)$$

(i) Deflection at C (i.e.,  $y_C$ )

By substituting  $x = 4$  in equation (iii) upto dotted line, we get the deflection at C.

$$\therefore EI y_C = -\frac{25}{3} \times 4^3 + 200 \times 4$$

$$= -533.33 + 800 = +266.67 \text{ kNm}^3$$

$$= 266.67 \times 10^{12} \text{ Nmm}^3$$

$$\therefore y_C = \frac{266.67 \times 10^{12}}{2 \times 10^5 \times 2 \times 10^8} = 6.66 \text{ mm upwards. Ans.}$$



## (ii) Maximum deflection

First find the point where maximum deflection takes place. The maximum deflection is likely to occur in the larger segment AC of the beam. For maximum deflection  $\frac{dy}{dx}$  should be zero. Hence equating the slope given by equation (i) upto dotted line to zero, we get

$$-\frac{50}{2}x^2 + 200 = 0 \quad (\because C_1 = 200)$$

$$\text{or} \quad -25x^2 + 200 = 0$$

$$\text{or} \quad x = \sqrt{\frac{200}{25}} = 2 \times \sqrt{2} \text{ m}$$

Now substituting  $x = 2 \times \sqrt{2}$  in equation (iii) upto dotted line, we get the maximum deflection.

$$\begin{aligned} \therefore EI \times y_{max} &= -\frac{25}{3} \times (2 \times \sqrt{2})^3 + 200(2 \times \sqrt{2}) \\ &= -188.56 + 565.68 \\ &= 377.12 \text{ kNm}^3 = 377.12 \times 10^{12} \text{ Nmm}^3 \end{aligned}$$

$$\therefore y_{max} = \frac{377.12 \times 10^{12}}{2 \times 10^5 \times 2 \times 10^8} = 9.428 \text{ mm upwards. Ans.}$$

## 12.8. MOMENT AREA METHOD

Fig. 12.17 shows a beam AB carrying some type of loading, and hence subjected to bending moment as shown in Fig. 12.17 (a). Let the beam bent into  $AQ_1P_1B$  as shown in Fig. 12.17 (b).

Due to the load acting on the beam. Let A be a point of zero slope and zero deflection.

Consider an element PQ of small length  $dx$  at a distance  $x$  from B. The corresponding points on the deflected beam are  $P_1Q_1$  as shown in Fig. 12.17 (b).

Let  $R$  = Radius of curvature of deflected part  $P_1Q_1$

$d\theta$  = Angle subtended by the arc  $P_1Q_1$  at the centre O

$M$  = Bending moment between P and Q

$P_1C$  = Tangent at point  $P_1$

$Q_1D$  = Tangent at point  $Q_1$ .

The tangent at  $P_1$  and  $Q_1$  are cutting the vertical line through B at points C and D. The angle between the normals at  $P_1$  and  $Q_1$  will be equal to the angle

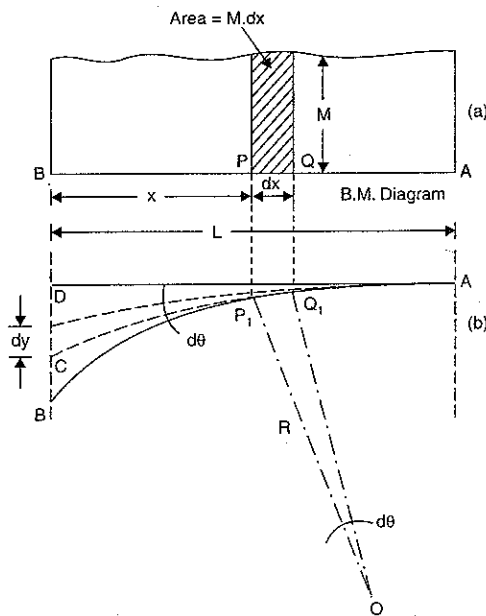

Fig. 12.17

between the tangents at  $P_1$  and  $Q_1$ . Hence the angle between the lines  $CP_1$  and  $DQ_1$  will be equal to  $d\theta$ .

For the deflected part  $P_1Q_1$  of the beam, we have

$$P_1Q_1 = R \cdot d\theta$$

$$\text{But} \quad P_1Q_1 = dx$$

$$\therefore dx = R \cdot d\theta$$

$$\therefore d\theta = \frac{dx}{R} \quad \dots(i)$$

But for a loaded beam, we have

$$\frac{M}{I} = \frac{E}{R} \quad \text{or} \quad R = \frac{EI}{M}$$

Substituting the values of  $R$  in equation (i), we get

$$d\theta = \frac{dx}{\left(\frac{EI}{M}\right)} = \frac{M \, dx}{EI} \quad \dots(ii)$$

Since the slope at point A is assumed zero, hence total slope at B is obtained by integrating the above equation between the limits 0 and L.

$$\therefore \theta = \int_0^L \frac{M \cdot dx}{EI} = \frac{1}{EI} \int_0^L M \cdot dx$$

But  $M \cdot dx$  represents the area of B. M. diagram of length  $dx$ . Hence  $\int_0^L M \cdot dx$  represents the area of B. M. diagram between A and B.

$$\therefore \theta = \frac{1}{EI} [\text{Area of B. M. diagram between A and B}]$$

$$\text{But} \quad \theta = \text{slope at B} = \theta_B$$

$\therefore$  Slope at B,

$$\theta_B = \frac{\text{Area of B. M. diagram between A and B}}{EI} \quad \dots(12.15)$$

If the slope at A is not zero then, we have

"Total change of slope between B and A is equal to the area of B. M. diagram between B and A divided by the flexural rigidity EI"

$$\text{or} \quad \theta_B - \theta_A = \frac{\text{Area of B.M. between A and B}}{EI} \quad \dots(12.16)$$

Now the deflection, due to bending of the portion  $P_1Q_1$  is given by

$$dy = x \cdot d\theta$$

Substituting the value of  $d\theta$  from equation (ii), we get

$$dy = x \cdot \frac{M \cdot dx}{EI} \quad \dots(iii)$$

Since deflection at A is assumed to be zero, hence the total deflection at B is obtained by integrating the above equation between the limits zero and L.

$$\therefore y = \int_0^L \frac{xM \cdot dx}{EI} = \frac{1}{EI} \int_0^L xM \cdot dx$$

But  $x \times M \cdot dx$  represents the moment of area of the B.M. diagram of length  $dx$  about point B.

Hence  $\int_0^L xM \cdot dx$  represents the moment of area of the B.M. diagram between  $B$  and  $A$  about  $B$ . This is equal to the total area of B.M. diagram between  $B$  and  $A$  multiplied by the distance of the C.G. of the B.M. diagram area from  $B$ .

$$\therefore y = \frac{1}{EI} \times A \times \bar{x} = \frac{A\bar{x}}{EI} \quad \dots(12.17)$$

where  $A$  = Area of B.M. diagram between  $A$  and  $B$   
 $\bar{x}$  = Distance of C.G. of the area  $A$  from  $B$ .

**12.9. MOHR'S THEOREMS**

The results given by equation (12.15) for slope and (12.17) for deflection are known as Mohr's theorems. They are state as :

- I. The change of slope between any two points is equal to the net area of the B.M. diagram between these points divided by  $EI$ .
- II. The total deflection between any two points is equal to the moment of the area of B.M. diagram between the two points about the last point (*i.e.*,  $B$ ) divided by  $EI$ .

The Mohr's theorems is conveniently used for following cases :

- 1. Problems on cantilevers (zero slope at fixed end).
- 2. Simply supported beams carrying symmetrical loading (zero slope at the centre).
- 3. Beams fixed at both ends (zero slope at each end).

The B.M. diagram is a parabola for uniformly distributed loads. The following properties of area and centroids or parabola are given as :

Let  $BC = d$   
 $AB = b$

In Fig. 12.18,  $ABC$  is a parabola and  $ABCD$  is a surrounding rectangle.

- Let  $A_1$  = Area of  $ABC$
- $\bar{x}_1$  = Distance of C.G. of  $A_1$  from  $AD$
- $A_2$  = Area of  $ACD$
- $\bar{x}_2$  = Distance of C.G. of  $A_2$  from  $AD$
- $G_1$  = C.G. of area  $A_1$
- $G_2$  = C.G. of area  $A_2$ .

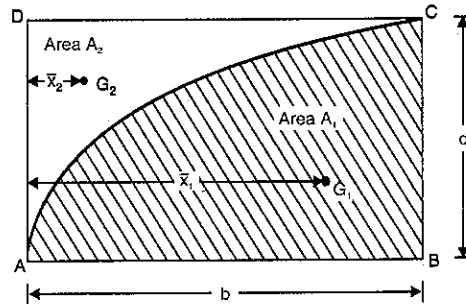

Fig. 12.18

Then  $A_1$  = Area of parabola  $ABC$   
 $= \frac{2}{3}bd$   
 $A_2$  = Area  $ACD$  = Area  $ABCD$  - Area  $ABC$   
 $= b \times d - \frac{2}{3}bd = \frac{1}{3}bd$   
 $\bar{x}_1 = \frac{5}{8}b$   
 $\bar{x}_2 = \frac{1}{4}b$ .

**12.10. SLOPE AND DEFLECTION OF A SIMPLY SUPPORTED BEAM CARRYING A POINT LOAD AT THE CENTRE BY MOHR'S THEOREM**

Fig. 12.19 (a) shows a simply supported  $AB$  of length  $L$  and carrying a point load  $W$  at the centre of the beam *i.e.*, at point  $C$ . The B.M. diagram is shown in Fig. 12.19 (b). This is a case of symmetrical loading, hence slope is zero at the centre *i.e.*, at point  $C$ .

But the deflection is maximum at the centre.

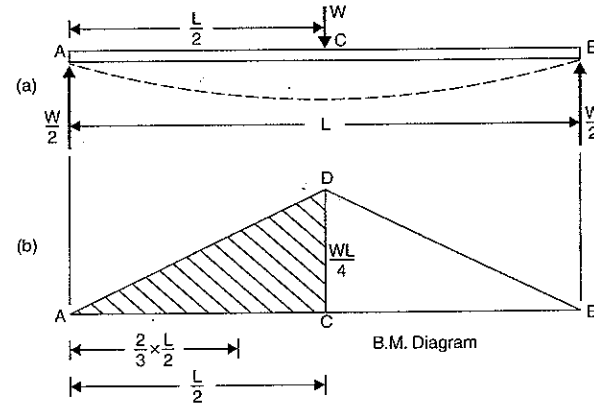

Fig. 12.19

Now using Mohr's theorem for slope, we get

Slope at  $A = \frac{\text{Area of B.M. diagram between A and C}}{EI}$

But area of B.M. diagram between  $A$  and  $C$   
 $=$  Area of triangle  $ACD$   
 $= \frac{1}{2} \times \frac{L}{2} \times \frac{WL}{4} = \frac{WL^2}{16}$

$\therefore$  Slope at  $A$  or  $\theta_A = \frac{WL^2}{EI}$

Now using Mohr's theorem for deflection, we get from equation (12.17) as

$$y = \frac{A\bar{x}}{EI}$$

where  $A$  = Area of B.M. Diagram between  $A$  and  $C$

$$= \frac{WL^2}{16}$$

$\bar{x}$  = Distance of C.G. of area  $A$  from  $A$

$$= \frac{2}{3} \times \frac{L}{2} = \frac{L}{3}$$

$$\therefore y = \frac{\frac{WL^2}{16} \times \frac{L}{3}}{EI} = \frac{WL^3}{48EI}$$

### 12.11. SLOPE AND DEFLECTION OF A SIMPLY SUPPORTED BEAM CARRYING A UNIFORMLY DISTRIBUTED LOAD BY MOHR'S THEOREM

Fig. 12.20 (a) shows a simply supported beam  $AB$  of length  $L$  and carrying a uniformly distributed load of  $w$ /unit length over the entire span. The B.M. diagram is shown in Fig. 12.20 (b). This is a case of symmetrical loading, hence slope is zero at the centre *i.e.*, at point  $C$ .

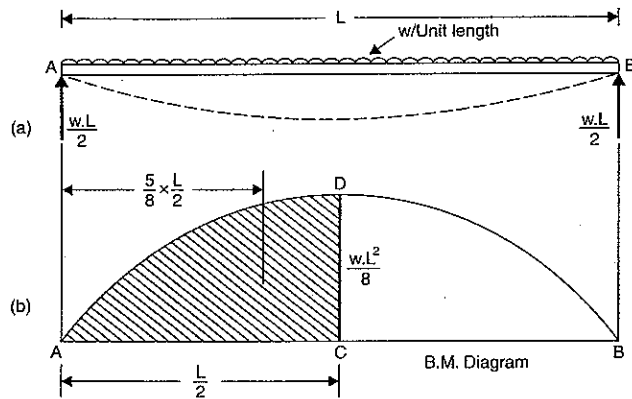

Fig. 12.20

(i) Now using Mohr's theorem for slope, we get

$$\text{Slope at } A = \frac{\text{Area of B.M. diagram between } A \text{ and } C}{EI}$$

$$\begin{aligned} \text{But area of B.M. diagram between } A \text{ and } C &= \text{Area of parabola } ACD \\ &= \frac{2}{3} \times AC \times CD \\ &= \frac{2}{3} \times \frac{L}{2} \times \frac{wL^2}{8} = \frac{w \cdot L^3}{24} \end{aligned}$$

$$\therefore \text{Slope at } A = \frac{w \cdot L^3}{24EI}$$

(ii) Now using Mohr's theorem for deflection, we get from equation (12.17) as

$$y = \frac{A\bar{x}}{EI}$$

where  $A$  = Area of B.M. diagram between  $A$  and  $C$

$$= \frac{w \cdot L^3}{24}$$

and  $\bar{x}$  = Distance of C.G. of area  $A$  from  $A$

$$= \frac{5}{8} \times AC = \frac{5}{8} \times \frac{L}{2} = \frac{5L}{16}$$

$$\therefore y = \frac{\frac{w \cdot L^3}{24} \times \frac{5L}{16}}{EI} = \frac{5}{384} \frac{w \cdot L^4}{EI}$$

### HIGHLIGHTS

1. The relation between curvature, slope, deflection etc. at a section is given by :

$$\text{Deflection} = y$$

$$\text{Slope} = \frac{dy}{dx}$$

$$\text{B.M.} = EI \frac{d^2y}{dx^2}$$

$$\text{S.F.} = EI \frac{d^3y}{dx^3}$$

$$w = EI \frac{d^4y}{dx^4}$$

As deflection is very small, hence slope is also given by  $\frac{dy}{dx} = \tan \theta = \theta$ .

2. Slope at the supports of a simply supported beam carrying a point load at the centre is given by :

$$\theta_A = \theta_B = -\frac{WL^2}{16EI}$$

where  $W$  = Point load at the centre,  $L$  = Length of beam

$E$  = Young's modulus,  $I$  = M.O.I.

3. The deflection at the centre of a simply supported beam carrying a point load at the centre is given by

$$y_C = -\frac{WL^3}{48EI}$$

4. The slope and deflection of a simply supported beam, carrying a uniformly distributed load of  $w$ /unit length over the entire span, are given by,

$$\theta_A = \theta_B = \frac{WL^2}{24EI} \quad \text{and} \quad y_C = \frac{5}{384} \frac{WL^2}{EI}$$

5. Macaulay's method is used in finding slopes and deflections at any point of a beam. In this method :

(i) Brackets are to be integrated as a whole.

(ii) Constants of integrations are written after the first term.

(iii) The section, for which B.M. equation is to be written, should be taken in the last part of the beam.

6. For maximum deflection, the slope  $\frac{dy}{dx}$  is zero.

7. The slope at point  $B$  if slope of  $A$  is zero by moment-area method is given by,

$$\theta_B = \frac{\text{Area of B.M. diagram between } A \text{ and } B}{EI}$$

8. The deflection by moment area method is given by

$$y = \frac{A\bar{x}}{EI}$$

where  $A$  = Area of B.M. diagram between  $A$  and  $B$

$\bar{x}$  = Distance of C.G. of area from  $B$ .

## EXERCISE 12

## (A) Theoretical Questions

1. Derive an expression for the slope and deflection of a beam subjected to uniform bending moment.

2. Prove that the relation that  $M = EI \frac{d^2y}{dx^2}$

where  $M$  = Bending moment,  $E$  = Young's modulus,  $I$  = M.O.I.

3. Find an expression for the slope at the supports of a simply supported beam, carrying a point load at the centre.

4. Prove that the deflection at the centre of a simply supported beam, carrying a point load at the centre, is given by  $y_c = \frac{WL^3}{48EI}$

where  $W$  = Point load,  $L$  = Length of beam.

5. Find an expression for the slope and deflection of a simply supported beam, carrying a point load  $W$  at a distance ' $a$ ' from left support and at a distance ' $b$ ' from right support where  $a > b$ .

6. Prove that the slope and deflection of a simply supported beam of length  $L$  and carrying a uniformly distributed load of  $w$  per unit length over the entire length are given by

$$\text{Slope at supports} = -\frac{WL^2}{24EI}, \text{ and Deflection at centre} = \frac{5}{384} \frac{WL^3}{EI}$$

where  $W$  = Total load =  $w \times L$ .

7. What is a Macaulay's method? Where is it used? Find an expression for deflection at any section of a simply supported beam with an eccentric point load, using Macaulay's method.
8. What is moment-area method? Where is it conveniently used? Find the slope and deflection of a simply supported beam carrying a (i) point load at the centre and (ii) uniformly distributed load over the entire length using moment-area method.

## (B) Numerical Problems

1. A wooden beam 4 m long, simply supported at its ends, is carrying a point load of 7.25 kN at its centre. The cross-section of the beam is 140 mm wide and 240 mm deep. If  $E$  for the beam =  $6 \times 10^3$  N/mm<sup>2</sup>, find the deflection at the centre. [Ans. 10 mm]

2. A beam 5 m long, simply supported at its ends, carries a point load  $W$  at its centre. If the slope at the ends of the beam is not to exceed  $1^\circ$ , find the deflection at the centre of the beam. [Ans. 29.08 mm]

3. Determine: (i) slope at the left support, (ii) deflection under the load and (iii) maximum deflection of a simply supported beam of length 10 m, which is carrying a point load of 10 kN at a distance 6 m from the left end.

Take  $E = 2 \times 10^5$  N/mm<sup>2</sup> and  $I = 1 \times 10^8$  mm<sup>4</sup>. [Ans. 0.00028 rad., 0.96 mm and 0.985 mm]

4. A beam of uniform rectangular section 100 mm wide and 240 mm deep is simply supported at its ends. It carries a uniformly distributed load of 9.125 kN/m run over the entire span of 4 m. Find the deflection at the centre if  $E = 1.1 \times 10^4$  N/mm<sup>2</sup>. [Ans. 6.01 mm]

5. A beam of length 4.8 m and of uniform rectangular section is simply supported at its ends. It carries a uniformly distributed load of 9.375 kN/m run over the entire length. Calculate the width and depth of the beam if permissible bending stress is 7 N/mm<sup>2</sup> and maximum deflection is not to exceed 0.95 cm.

Take  $E$  for beam material =  $1.05 \times 10^4$  N/mm<sup>2</sup>. [Ans.  $b = 240$  mm and  $d = 336.8$  mm]

6. Solve problem 3, using Macaulay's method.

7. A beam of length 10 m is simply supported at its ends and carries two point loads of 100 kN and 60 kN at a distance of 2 m and 5 m respectively from the left support. Calculate the deflections under each load. Find also the maximum deflection.

Take  $I = 18 \times 10^8$  mm<sup>4</sup> and  $E = 2 \times 10^5$  N/mm<sup>2</sup>.

[Ans. (i) - 4.35 mm (ii) - 6.76 mm (iii)  $y_{max} = -6.78$  mm]

8. A beam of length 20 m is simply supported at its ends and carries two point loads of 4 kN and 10 kN at a distance of 8 m and 12 m from left end respectively. Calculate: (i) deflection under each load (ii) maximum deflection.

Take  $E = 2 \times 10^6$  N/mm<sup>2</sup> and  $I = 1 \times 10^9$  mm<sup>4</sup>.

[Ans. (i) 10.3 mm and 10.6 downwards, (ii) 11 mm]

9. A beam of length 6 m is simply supported at its ends. It carries a uniformly distributed load of 10 kN/m as shown in Fig. 12.21. Determine the deflection of the beam at its mid-point and also the position and the maximum deflection.

Take  $EI = 4.5 \times 10^8$  N/mm<sup>2</sup>.

[Ans. - 2.578 mm,  $x = 2.9$  m,  $y_{max} = -2.582$  mm]

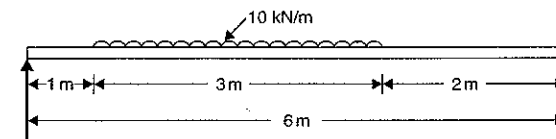

Fig. 12.21

10. A beam  $ABC$  of length 12 metre has one support at the left end and other support at a distance of 8 m from the left end. The beam carries a point load of 12 kN at the right end as shown in Fig. 12.22. Find the slopes over each support and at the right end. Find also the deflection at the right end.

Take  $E = 2 \times 10^5$  N/mm<sup>2</sup> and  $I = 5 \times 10^8$  mm<sup>4</sup>.

[Ans.  $\theta_A = 6.00364$ ,  $\theta_B = -0.00128$ ,  $\theta_C = -0.00224$ ,  $y_C = -7.68$  mm]

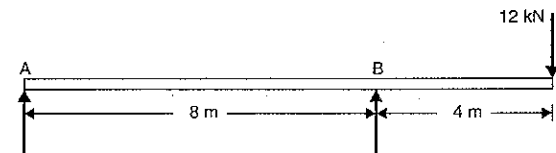

Fig. 12.22

11. An overhanging beam  $ABC$  is loaded as shown in Fig. 12.23. Determine the deflection of the beam at point  $C$ .

Take  $E = 2 \times 10^5$  N/mm<sup>2</sup> and  $I = 5 \times 10^8$  mm<sup>4</sup>.

[Ans.  $y_c = -4.16$  mm]

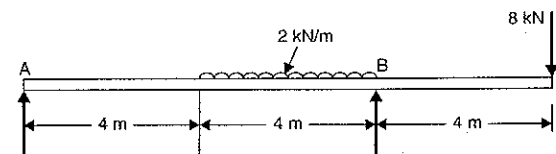

Fig. 12.23

12. A beam of span 8 m and of uniform flexural rigidity  $EI = 40$  MN-m<sup>2</sup>, is simply supported at its ends. It carries a uniformly distributed load of 15 kN/m run over the entire span. It is also subjected to a clockwise moment of 160 kNm at a distance of 3 m from the left support. Calculate the slope of the beam at the point of application of the moment. [Ans. 0.0061 rad.]

## Deflection of Cantilevers

### 13.1. INTRODUCTION

Cantilever is a beam whose one end is fixed and other end is free. In this chapter we shall discuss the methods of finding slope and deflection for the cantilevers when they are subjected to various types of loading. The important methods are (i) Double integration method (ii) Macaulay's method and (iii) Moment-area-method. These methods have also been used for finding deflections and slope of the simply supported beams.

### 13.2. DEFLECTION OF A CANTILEVER WITH A POINT LOAD AT THE FREE END BY DOUBLE INTEGRATION METHOD

A cantilever  $AB$  of length  $L$  fixed at the point  $A$  and free at the point  $B$  and carrying a point load at the free end  $B$  is shown in Fig. 13.1.  $AB$  shows the position of cantilever before any load is applied whereas  $AB'$  shows the position of the cantilever after loading.

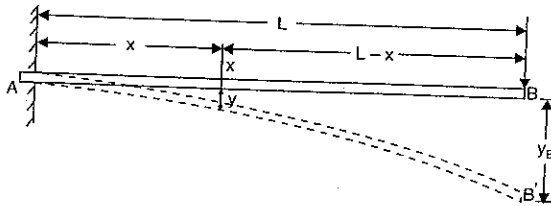

Fig. 13.1

Consider a section  $X$ , at a distance  $x$  from the fixed end  $A$ . The B.M. at this section is given by,

$$M_x = -W(L-x) \quad (\text{Minus sign due to hogging})$$

But B.M. at any section is also given by equation (12.3) as

$$M = EI \frac{d^2y}{dx^2}$$

Equating the two values of B.M., we get

$$EI \frac{d^2y}{dx^2} = -W(L-x) = -WL + Wx$$

Integrating the above equation, we get

$$EI \frac{dy}{dx} = -WLx + \frac{Wx^2}{2} + C_1 \quad \dots(i)$$

Integration again, we get

$$EIy = -WL \frac{x^2}{2} + \frac{W}{2} \frac{x^3}{3} + C_1x + C_2 \quad \dots(ii)$$

where  $C_1$  and  $C_2$  are constant of integrations. Their values are obtained from boundary conditions, which are : (i) at  $x = 0, y = 0$  (ii)  $x = 0, \frac{dy}{dx} = 0$

[At the fixed end, deflection and slopes are zero]

(i) By substituting  $x = 0, y = 0$  in equation (ii), we get

$$0 = 0 + 0 + 0 + C_2 \quad \therefore C_2 = 0$$

(ii) By substituting  $x = 0, \frac{dy}{dx} = 0$  in equation (i), we get

$$0 = 0 + 0 + C_1 \quad \therefore C_1 = 0$$

Substituting the value of  $C_1$  in equation (i), we get

$$\begin{aligned} EI \frac{dy}{dx} &= -WLx + \frac{Wx^2}{2} \\ &= -W \left( Lx - \frac{x^2}{2} \right) \end{aligned} \quad \dots(iii)$$

The equation (iii) is known as *slope equation*. We can find the slope at any point on the cantilever by substituting the value of  $x$ . The slope and deflection are maximum at the free end. These can be determined by substituting  $x = L$  in these equations.

Substituting the values of  $C_1$  and  $C_2$  in equation (ii), we get

$$\begin{aligned} EIy &= -WL \frac{x^2}{2} + \frac{Wx^3}{6} \quad (\because C_1 = 0, C_2 = 0) \\ &= -W \left( \frac{Lx^2}{2} - \frac{x^3}{6} \right) \end{aligned} \quad \dots(iv)$$

The equation (iv) is known as *deflection equation*.

Let  $\theta_B =$  slope at the free end  $B$  i.e.,  $\left( \frac{dy}{dx} \right)$  at  $B = \theta_B$  and

$y_B =$  Deflection at the free end  $B$

(a) Substituting  $\theta_B$  for  $\frac{dy}{dx}$  and  $x = L$  in equation (iii), we get

$$EI\theta_B = -W \left( L \cdot L - \frac{L^2}{2} \right) = -W \cdot \frac{L^2}{2}$$

$$\therefore \theta_B = -\frac{WL^2}{2EI} \quad \dots(13.1)$$

Negative sign shows that tangent at  $B$  makes an angle in the anti-clockwise direction with  $AB$

$$\therefore \theta_B = \frac{WL^2}{2EI} \quad \dots(13.1A)$$

(b) Substituting  $y_B$  for  $y$  and  $x = L$  in equation (iv), we get

$$EI y_B = -W \left( L \cdot \frac{L^2}{2} - \frac{L^3}{6} \right) = -W \left( \frac{L^3}{2} - \frac{L^3}{6} \right) = -W \cdot \frac{L^3}{3}$$

$$\therefore y_B = -\frac{WL^3}{3EI} \quad \dots(13.2)$$

(Negative sign shows that deflection is downwards)

$$\therefore \text{Downward deflection, } y_B = \frac{WL^3}{3EI} \quad \dots(13.2 A)$$

### 13.3. DEFLECTION OF A CANTILEVER WITH A POINT LOAD AT A DISTANCE 'a' FROM THE FIXED END

A cantilever AB of length  $L$  fixed at point A and free at point B and carrying a point load  $W$  at a distance 'a' from the fixed end A, is shown in Fig. 13.2.

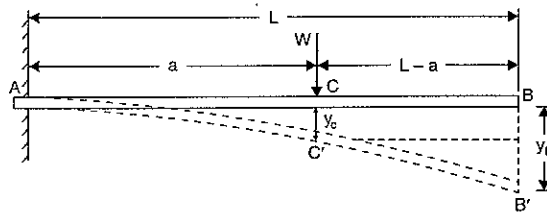

Fig. 13.2

Let  $\theta_C = \text{Slope at point C i.e., } \left( \frac{dy}{dx} \right) \text{ at C}$

$y_C = \text{Deflection at point C}$

$y_B = \text{Deflection at point B}$

The portion AC of the cantilever may be taken as similar to a cantilever in Art. 13.1 (i.e., load at the free end).

$$\therefore \theta_C = +\frac{Wa^2}{2EI} \quad [\text{In equation (13.1 A) change } L \text{ to } a]$$

and  $y_C = \frac{Wa^3}{3EI} \quad [\text{In equation (13.2 A) change } L \text{ to } a]$

The beam will bend only between A and C, but from C to B it will remain straight since B.M. between C and B is zero.

Since the portion CB of the cantilever is straight, therefore

Slope at C = slope at B

or  $\theta_C = \theta_B = \frac{Wa^2}{2EI} \quad \dots(13.3)$

Now from Fig. 13.2, we have

$$y_B = y_C + \theta_C(L-a) = \frac{Wa^3}{3EI} + \frac{Wa^2}{2EI}(L-a) \quad \left( \because \theta_C = \frac{Wa^2}{2EI} \right) \quad \dots(13.4)$$

**Problem 13.1.** A cantilever of length 3 m is carrying a point load of 25 kN at the free end. If the moment of inertia of the beam =  $10^8 \text{ mm}^4$  and value of  $E = 2.1 \times 10^5 \text{ N/mm}^2$ , find (i) slope of the cantilever at the free end and (ii) deflection at the free end.

**Sol.** Given :

Length,  $L = 3 \text{ m} = 3000 \text{ mm}$

Point load,  $W = 25 \text{ kN} = 25000 \text{ N}$

M.O.I.,  $I = 10^8 \text{ mm}^4$

Value of  $E = 2.1 \times 10^5 \text{ N/mm}^2$

(i) Slope at the free end is given by equation (13.1 A).

$$\therefore \theta_B = \frac{WL^2}{2EI} = \frac{25000 \times 3000^2}{2 \times 2.1 \times 10^5 \times 10^8} = 0.005357 \text{ rad. Ans.}$$

(ii) Deflection at the free end is given by equation (13.2 A),

$$y_B = \frac{WL^3}{3EI} = \frac{25000 \times 3000^3}{3 \times 2.1 \times 10^5 \times 10^8} = 10.71 \text{ mm. Ans.}$$

**Problem 13.2.** A cantilever of length 3 m is carrying a point load of 50 kN at a distance of 2 m from the fixed end. If  $I = 10^8 \text{ mm}^4$  and  $E = 2 \times 10^5 \text{ N/mm}^2$ , find (i) slope at the free end and (ii) deflection at the free end.

**Sol.** Given :

Length,  $L = 3 \text{ m} = 3000 \text{ mm}$

Point load,  $W = 50 \text{ kN} = 50000 \text{ N}$

Distance between the load and the fixed end,

$a = 2 \text{ m} = 2000 \text{ mm}$

M.O.I.,  $I = 10^8 \text{ mm}^4$

Value of  $E = 2 \times 10^5 \text{ N/mm}^2$

(i) Slope at the free end is given by equation (13.3) as

$$\theta_B = \frac{Wa^2}{2EI} = \frac{50000 \times 2000^2}{2 \times 2 \times 10^5 \times 10^8} = 0.005 \text{ rad. Ans.}$$

(ii) Deflection at the free end is given by equation (13.4) as

$$y_B = \frac{Wa^3}{3EI} + \frac{Wa^2}{2EI}(L-a) = \frac{50000 \times 2000^3}{3 \times 2 \times 10^5 \times 10^8} + \frac{50000 \times 2000^2}{2 \times 2 \times 10^5 \times 10^8} (3000 - 2000) = 6.67 + 5.0 = 11.67 \text{ mm. Ans.}$$

### 13.4. DEFLECTION OF A CANTILEVER WITH A UNIFORMLY DISTRIBUTED LOAD

A cantilever AB of length  $L$  fixed at the point A and free at the point B and carrying a uniformly distributed load of  $w$  per unit length over the whole length, is shown in Fig. 13.3.

Consider a section X, at a distance  $x$  from the fixed end A. The B.M. at this section is given by,

$$M_x = -w(L-x) \cdot \frac{(L-x)}{2} \quad (\text{Minus sign due to hogging})$$

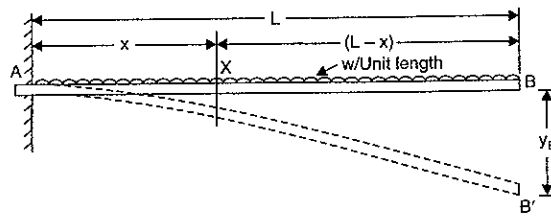

Fig. 13.3

But B.M. at any section is also given by equation (12.3) as

$$M = EI \frac{d^2 y}{dx^2}$$

Equating the two values of B.M., we get

$$EI \frac{d^2 y}{dx^2} = -\frac{w}{2} (L-x)^2$$

Integrating the above equation, we get

$$\begin{aligned} EI \frac{dy}{dx} &= -\frac{w}{2} \frac{(L-x)^3}{3} (-1) + C_1 \\ &= \frac{w}{6} (L-x)^3 + C_1 \end{aligned} \quad \dots(i)$$

Integrating again, we get

$$\begin{aligned} EIy &= \frac{w}{6} \cdot \frac{(L-x)^4}{4} (-1) + C_1 x + C_2 \\ &= -\frac{w}{24} (L-x)^4 + C_1 x + C_2 \end{aligned} \quad \dots(ii)$$

where  $C_1$  and  $C_2$  are constant of integrations. Their values are obtained from boundary conditions, which are: (i) at  $x = 0, y = 0$  and (ii) at  $x = 0, \frac{dy}{dx} = 0$  (as the deflection and slope at fixed end A are zero).

(i) By substituting  $x = 0, y = 0$  in equation (ii), we get

$$0 = -\frac{w}{24} (L-0)^4 + C_1 \times 0 + C_2 = -\frac{wL^4}{24} + C_2$$

$$\therefore C_2 = \frac{wL^4}{24}$$

(ii) By substituting  $x = 0$  and  $\frac{dy}{dx} = 0$  in equation (i), we get

$$0 = \frac{w}{6} (L-0)^3 + C_1 = \frac{wL^3}{6} + C_1$$

$$\therefore C_1 = -\frac{wL^3}{6}$$

Substituting the values of  $C_1$  and  $C_2$  in equation (i) and (ii), we get

$$EI \frac{dy}{dx} = \frac{w}{6} (L-x)^3 - \frac{wL^3}{6} \quad \dots(iii)$$

and

$$EIy = -\frac{w}{24} (L-x)^4 - \frac{wL^3}{6} x + \frac{wL^4}{24} \quad \dots(iv)$$

The equation (iii) is known as *slope equation* and equation (iv) as *deflection equation*. From these equations the slope and deflection can be obtained at any sections. To find the slope and deflection at point B, the value of  $x = L$  is substituted in these equations.

Let  $\theta_B =$  Slope at the free end B i.e.,  $\left(\frac{dy}{dx}\right)$  at B

$y_B =$  Deflection at the free end B.

From equation (iii), we get slope at B as

$$EI \theta_B = \frac{w}{6} (L-L)^3 - \frac{wL^3}{6} = -\frac{wL^3}{6}$$

$$\therefore \theta_B = -\frac{wL^3}{6EI} = -\frac{WL^2}{6EI} \quad (\because W = \text{Total load} = wL) \quad \dots(13.5)$$

From equation (iv), we get the deflection at B as

$$\begin{aligned} EI y_B &= -\frac{w}{24} (L-L)^4 - \frac{wL^3}{6} \times L + \frac{wL^4}{24} \\ &= -\frac{wL^4}{6} + \frac{wL^4}{24} = -\frac{3}{24} wL^4 = -\frac{wL^4}{8} \end{aligned}$$

$$\therefore y_B = -\frac{wL^4}{8EI} = -\frac{WL^3}{8EI} \quad (\because W = wL)$$

$\therefore$  Downward deflection at B,

$$y_B = \frac{wL^4}{8EI} = \frac{WL^3}{8EI} \quad \dots(13.6)$$

**Problem 13.3.** A cantilever of length 2.5 m carries a uniformly distributed load of 16.4 kN per metre length over the entire length. If the moment of inertia of the beam =  $7.95 \times 10^7 \text{ mm}^4$  and value of  $E = 2 \times 10^5 \text{ N/mm}^2$ , determine the deflection at the free end.

**Sol.** Given :

Length,  $L = 2.5 \text{ m} = 2500 \text{ mm}$

U.d.l.,  $w = 16.4 \text{ kN/m}$

$\therefore$  Total load,  $W = w \times L = 16.4 \times 2.5 = 41 \text{ kN} = 41000 \text{ N}$

Value of  $I = 7.95 \times 10^7 \text{ mm}^4$

Value of  $E = 2 \times 10^5 \text{ N/mm}^2$

Let  $y_B =$  Deflection at the free end,

Using equation (13.6), we get

$$\begin{aligned} y_B &= \frac{WL^3}{8EI} = \frac{41000 \times 2500^3}{8 \times 2 \times 10^5 \times 7.95 \times 10^7} \\ &= 5.036 \text{ mm. Ans.} \end{aligned}$$

**Problem 13.4.** A cantilever of length 3 m carries a uniformly distributed load over the entire length. If the deflection at the free end is 40 mm, find the slope at the free end.

Sol. Given :

Length,  $L = 3 \text{ m} = 3000 \text{ m}$

Deflection at free end,  $y_B = 40 \text{ mm}$

Let  $\theta_B = \text{slope at the free end}$

Using equation (13.6), we get

$$y_B = \frac{WL^3}{8EI}$$

$$40 = \frac{WL^2 \times L}{8EI} = \frac{WL^2 \times 3000}{8EI}$$

$$\frac{WL^2}{EI} = \frac{40 \times 8}{3000} \quad \dots(i)$$

Slope at the free end is given by equation (13.5),

$$\theta_B = -\frac{WL^2}{6EI} = -\frac{WL^2}{EI} \times \frac{1}{6} = -\frac{40 \times 8}{3000} \times \frac{1}{6}$$

$$\left[ \because \text{From equation (i), } \frac{WL^2}{EI} = \frac{40 \times 8}{3000} \right]$$

$$= 0.01777 \text{ rad. Ans.}$$

**Problem 13.4 (A).** A cantilever 120 mm wide and 200 mm deep is 2.5 m long. What is the uniformly distributed load which the beam can carry in order to produce a deflection of 5 mm at the free end? Take  $E = 200 \text{ GN/m}^2$ . (Annamalai University, 1991)

Sol. Given :

Width,  $b = 120 \text{ mm}$

Depth,  $d = 200 \text{ mm}$

Length,  $L = 2.5 \text{ m} = 2.5 \times 1000 = 2500 \text{ mm}$

Deflection at free end,  $y_B = 5 \text{ mm}$

Value of  $E = 200 \text{ GN/m}^2 = 200 \times 10^9 \text{ N/m}^2$  ( $\because G = \text{Giga} = 10^9$ )

$$= \frac{200 \times 10^9 \text{ N}}{(1000)^2 \text{ mm}^2} \quad [\because 1 \text{ m}^2 = (1000 \text{ mm})^2]$$

$$= 2 \times 10^5 \text{ N/mm}^2$$

$$\text{Moment of inertia, } I = \frac{bd^3}{12} = \frac{120 \times 200^3}{12} = 8 \times 10^7 \text{ mm}^4$$

Let  $w = \text{uniformly distributed load per m length in N}$

$W = \text{Total load}$

$$= w \times L$$

$$= w \times 2.5 = 2.5 \times w \text{ N}$$

(Here  $L$  is in metre)

Using equation (13.6), we get

$$y_B = \frac{WL^3}{8EI}$$

$$5 = \frac{2.5w \times 2500^3}{8 \times 2 \times 10^5 \times 8 \times 10^7}$$

or

$$\text{or } w = \frac{5 \times 8 \times 2 \times 10^5 \times 8 \times 10^7}{2.5 \times 2500^3} = 16384 \text{ N/m}$$

$$= 16.384 \text{ kN/m. Ans.}$$

### 13.5. DEFLECTION OF A CANTILEVER WITH A UNIFORMLY DISTRIBUTED LOAD FOR A DISTANCE 'a' FROM THE FIXED END

A cantilever  $AB$  of length  $L$  fixed at the point  $A$  and free at the point  $B$  and carrying a uniformly distributed load of  $w/m$  length for a distance 'a' from the fixed end, is shown in Fig. 13.4.

The beam will bend only between  $A$  and  $C$ , but from  $C$  to  $B$  it will remain straight since B.M. between  $C$  and  $B$  is zero. The deflected shape of the cantilever is shown by  $AC'B'$  in which portion  $C'B'$  is straight.

Let  $\theta_C = \text{Slope at } C, \text{ i.e., } \left(\frac{dy}{dx}\right) \text{ at } C$

$y_C = \text{Deflection at point } C, \text{ and}$

$y_B = \text{Deflection at point } B.$

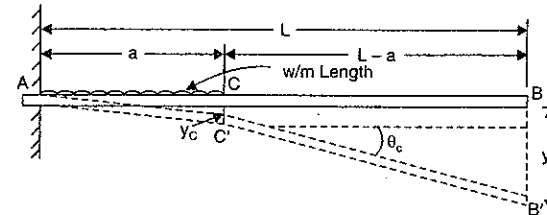

Fig. 13.4

The portion  $AC$  of the cantilever may be taken as similar to a cantilever in Art. 13.4.

$$\therefore \theta_C = \frac{w \cdot a^3}{6EI} \quad [\text{In equation (13.5) put } L = a]$$

and

$$y_C = \frac{w \cdot a^4}{8EI} \quad [\text{In equation (13.6) put } L = a]$$

Since the portion  $C'B'$  of the cantilever is straight, therefore slope at  $C = \text{slope at } B$

$$\text{or } \theta_C = \theta_B = \frac{wa^3}{6EI} \quad \dots(13.7)$$

Now from Fig. 13.4, we have

$$y_B = y_C + \theta_C(L - a)$$

$$= \frac{wa^4}{8EI} + \frac{w \cdot a^3}{6EI}(L - a) \quad \dots(13.8)$$

### 13.6. DEFLECTION OF A CANTILEVER WITH A UNIFORMLY DISTRIBUTED LOAD FOR A DISTANCE 'a' FROM THE FREE END

A cantilever  $AB$  of length  $L$  fixed at the point  $A$  and free at the point  $B$  and carrying a uniformly distributed load of  $w/m$  length for a distance 'a' from the free end is shown in Fig. 13.5 (a).



The slope and deflection at the point  $B$  is determined by considering :

(i) the whole cantilever  $AB$  loaded with a uniformly distributed load of  $w$  per unit length as shown in Fig. 13.5 (b).

(ii) a part of cantilever from  $A$  to  $C$  of length  $(L - a)$  loaded with an upward uniformly distributed load of  $w$  per unit length as shown in Fig. 13.5 (c).

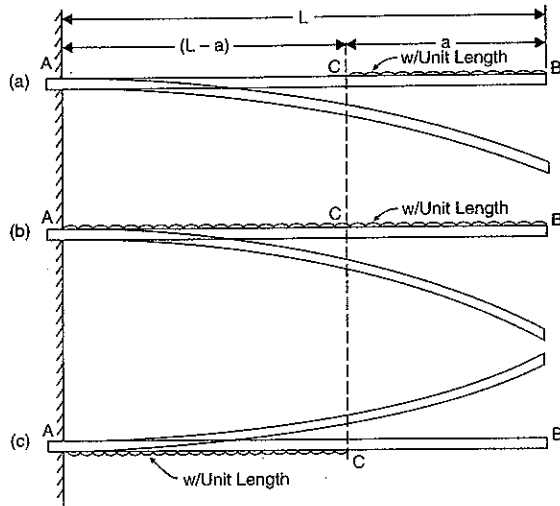

Fig. 13.5

Then slope at  $B$  = Slope due to downward uniform load over the whole length  
 - slope due to upward uniform load from  $A$  to  $C$

and deflection at  $B$  = Deflection due to downward uniform load over the whole length  
 - deflection due to upward uniform load from  $A$  to  $C$ .

(a) Now slope at  $B$  due to downward uniformly distributed load over the whole length

$$= \frac{wL^3}{6EI}$$

(b) Slope at  $B$  or at  $C$  due to upward uniformly distributed load over the length  $(L - a)$

$$= \frac{w(L - a)^3}{6EI}$$

Hence net slope at  $B$  is given by,

$$\theta_B = \frac{wL^3}{6EI} - \frac{w(L - a)^3}{6EI} \quad \dots(13.9)$$

The downward deflection of point  $B$  due to downward distributed load over the whole length  $AB$

$$= \frac{wL^4}{8EI}$$

The upward deflection of point  $B$  due to upward uniformly distributed load acting on the portion  $AC$  = upward deflection of  $C$  + slope at  $C$   $\times CB$

$$= \frac{w(L - a)^4}{8EI} + \frac{w \cdot (L - a)^3}{6EI} \times a \quad (\because CB = a)$$

$\therefore$  Net downward deflection of the free end  $B$  is given by

$$y_B = \frac{wL^4}{8EI} - \left[ \frac{w(L - a)^4}{8EI} + \frac{w(L - a)^3}{6EI} \times a \right] \quad \dots(13.10)$$

**Problem 13.5.** Determine the slope and deflection of the free end of a cantilever of length 3 m which is carrying a uniformly distributed load of 10 kN/m over a length of 2 m from the fixed end.

Take  $I = 10^8 \text{ mm}^4$  and  $E = 2 \times 10^5 \text{ N/mm}^2$ .

**Sol.** Given :

Length,  $L = 3 \text{ m} = 3000 \text{ mm}$

U.d.l.,  $w = 10 \text{ kN/m} = 10000 \text{ N/m} = \frac{10000}{1000} \text{ N/mm} = 10 \text{ N/mm}$

Length of u.d.l. from fixed end,  $a = 2 \text{ m} = 2000 \text{ mm}$ .

Value of  $I = 10^8 \text{ mm}^4$

Value of  $E = 2 \times 10^5 \text{ N/mm}^2$

Let  $\theta_B$  = Slope of the free end and

$y_B$  = Deflection at the free end.

(i) Using equation (13.7), we have

$$\theta_B = \frac{w a^3}{6EI} = \frac{10 \times 2000^3}{6 \times 2 \times 10^5 \times 10^8} = 0.00066. \text{ Ans.}$$

(ii) Using equation (13.8), we get

$$\begin{aligned} y_B &= \frac{w a^4}{8EI} + \frac{w \cdot a^3}{6EI} (L - a) \\ &= \frac{10 \times 2000^4}{8 \times 2 \times 10^5 \times 10^8} + \frac{10 \times 2000^3}{6 \times 2 \times 10^5 \times 10^8} \times (3000 - 2000) \\ &= 1 + 0.67 = 1.67 \text{ mm. Ans.} \end{aligned}$$

**Problem 13.6.** A cantilever of length 3 m carries a uniformly distributed load of 10 kN/m over a length of 2 m from the free end. If  $I = 10^8 \text{ mm}^4$  and  $E = 2 \times 10^5 \text{ N/mm}^2$ ; find : (i) slope at the free end, and (ii) deflection at the free end.

**Sol.** Given :

Length,  $L = 3 \text{ m} = 3000 \text{ mm}$

U.d.l.,  $w = 10 \text{ kN/m} = 10000 \text{ N/m} = \frac{10000}{1000} \text{ N/mm} = 10 \text{ N/mm}$

Length of u.d.l. from free end,  $a = 2 \text{ m} = 2000 \text{ mm}$

Value of  $I = 10^8 \text{ mm}^4$

Value of  $E = 2 \times 10^5 \text{ N/mm}^2$

Let  $\theta_B =$  Slope at the free end i.e.,  $\left(\frac{dy}{dx}\right)$  at B and

$y_B =$  Deflection at the free end.

(i) Using equation (13.9), we get

$$\begin{aligned}\theta_B &= \frac{wL^3}{6EI} - \frac{w(L-a)^3}{6EI} \\ &= \frac{10 \times 3000^3}{6 \times 2 \times 10^5 \times 10^8} - \frac{10(3000-2000)^3}{6 \times 2 \times 10^5 \times 10^8} \\ &= 0.00225 - 0.000083 = \mathbf{0.002167 \text{ rad.}} \quad \text{Ans.}\end{aligned}$$

(ii) Using equation (13.10), we get

$$\begin{aligned}y_B &= \frac{wL^4}{8EI} - \left[ \frac{w(L-a)^4}{8EI} + \frac{w(L-a)^3}{6EI} \times a \right] \\ &= \frac{10 \times 3000^4}{8 \times 2 \times 10^5 \times 10^8} - \left[ \frac{10(3000-2000)^4}{8 \times 2 \times 10^5 \times 10^8} + \frac{10(3000-2000)^3}{6 \times 2 \times 10^5 \times 10^8} \times 2000 \right] \\ &= 5.0625 - [0.0625 + 0.1667] = \mathbf{4.8333 \text{ mm.}} \quad \text{Ans.}\end{aligned}$$

**Problem 13.7.** A cantilever of length 3 m carries two point loads of 2 kN at the free end and 4 kN at a distance of 1 m from the free end. Find the deflection at the free end.

Take  $E = 2 \times 10^5 \text{ N/mm}^2$  and  $I = 10^8 \text{ mm}^4$ .

Sol. Given :

Length,  $L = 3 \text{ m} = 3000 \text{ mm}$

Load at free end,  $W_1 = 2 \text{ kN} = 2000 \text{ N}$

Load at a distance one m from free end,

$W_2 = 4 \text{ kN} = 4000 \text{ N}$

Distance AC,  $a = 2 \text{ m} = 2000 \text{ mm}$

Value of  $E = 2 \times 10^5 \text{ N/mm}^2$

Value of  $I = 10^8 \text{ mm}^4$

Let  $y_1 =$  Deflection at the free end due to load 2 kN alone

$y_2 =$  Deflection at the free end due to load 4 kN alone.

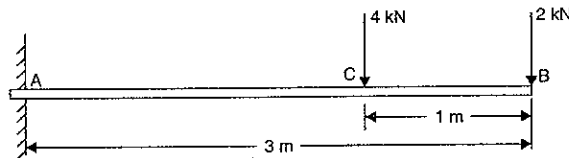

Fig. 13.6

Downward deflection due to load 2 kN alone at the free end is given by equation (13.2 A)

as

$$y_1 = \frac{WL^3}{3EI} = \frac{2000 \times 3000^3}{3 \times 2 \times 10^5 \times 10^8} = 0.9 \text{ mm.}$$

Downward deflection at the free end due to load 4 kN (i.e., 4000 N) alone at a distance 2 m from fixed end is given by (13.4) as

$$\begin{aligned}y_2 &= \frac{Wa^3}{3EI} + \frac{Wa^2}{2EI} (L-a) \\ &= \frac{4000 \times 2000^3}{3 \times 2 \times 10^5 \times 10^8} + \frac{4000 \times 2000^2}{2 \times 2 \times 10^5 \times 10^8} (3000 - 2000) \\ &= 0.54 + 0.40 = 0.94 \text{ mm}\end{aligned}$$

$\therefore$  Total deflection at the free end

$$\begin{aligned}&= y_1 + y_2 \\ &= 0.9 + 0.94 = \mathbf{1.84 \text{ mm.}} \quad \text{Ans.}\end{aligned}$$

**Problem 13.8.** A cantilever of length 2 m carries a uniformly distributed load of 2.5 kN/m run for a length of 1.25 m from the fixed end and a point load of 1 kN at the free end. Find the deflection at the free end if the section is rectangular 12 cm wide and 24 cm deep and  $E = 1 \times 10^4 \text{ N/mm}^2$ . (Annamalai University, 1990)

Sol. Given :

Length,  $L = 2 \text{ m} = 2000 \text{ mm}$

U.d.l.,  $w = 2.5 \text{ kN/m} = 2.5 \times 1000 \text{ N/m}$

$$= \frac{2.5 \times 1000}{1000} \text{ N/mm} = 2.5 \text{ N/mm}$$

Point load at free end,  $W = 1 \text{ kN} = 1000 \text{ N}$

Distance AC,  $a = 1.25 \text{ m} = 1250 \text{ mm}$

Width,  $b = 12 \text{ mm}$

Depth,  $d = 24 \text{ mm}$

Value of  $I = \frac{bd^3}{12} = \frac{12 \times 24^3}{12}$

$$= 13824 \text{ cm}^4 = 13824 \times 10^4 \text{ mm}^4 = 1.3824 \times 10^4 \text{ mm}^4$$

Value of  $E = 1 \times 10^4 \text{ N/mm}^2$

Let  $y_1 =$  Deflection at the free end due to point load 1 kN alone

$y_2 =$  Deflection at the free end due to u.d.l. on length AC.

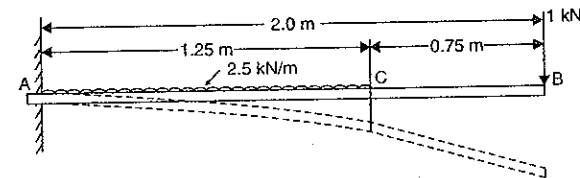

Fig. 13.7

(i) Now the downward deflection at the free end due to point load of 1 kN (or 1000 N) at the free end is given by equation (13.2 A) as

$$y_1 = \frac{WL^3}{3EI} = \frac{1000 \times 2000^3}{3 \times 10^4 \times 1.3824 \times 10^8} = 1.929 \text{ mm.}$$

(ii) The downward deflection at the free end due to uniformly distributed load of 2.5 N/mm on a length of 1.25 m (or 1250 mm) is given by equation (13.8) as

$$y_2 = \frac{wa^4}{8EI} + \frac{w \cdot a^3}{6EI} (L-a)$$

$$= \frac{2.5 \times 1250^4}{8 \times 10^4 \times 1.3824 \times 10^8} + \frac{2.5 \times 1250^3}{6 \times 10^4 \times 1.3824 \times 10^8} (2000 - 1250)$$

$$= 0.5519 + 0.4415 = 0.9934$$

∴ Total deflection at the free end due to point load and u.d.l.

$$= y_1 + y_2 = 1.929 + 0.9934 = 2.9224 \text{ mm. Ans.}$$

**Problem 13.9.** A cantilever of length 2 m carries a uniformly distributed load 2 kN/m over a length of 1 m from the free end, and a point load of 1 kN at the free end. Find the slope and deflection at the free end if  $E = 2.1 \times 10^5 \text{ N/mm}^2$  and  $I = 6.667 \times 10^7 \text{ mm}^4$ .

**Sol.** Given : (See Fig. 13.8)

Length,  $L = 2 \text{ m} = 2000 \text{ mm}$

U.d.l.  $w = 2 \text{ kN/m} = \frac{2 \times 1000}{1000} \text{ N/mm} = 2 \text{ N/mm}$

Length BC,  $a = 1 \text{ m} = 1000 \text{ mm}$

Point load,  $W = 1 \text{ kN} = 1000 \text{ N}$

Value of  $E = 2.1 \times 10^5 \text{ N/mm}^2$

Value of  $I = 6.667 \times 10^7 \text{ mm}^4$ .

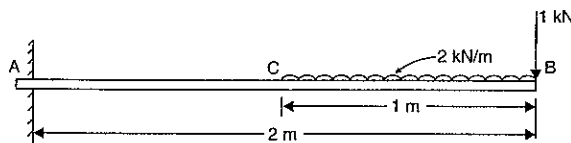

Fig. 13.8

(i) Slope at the free end

Let  $\theta_1 =$  Slope at the free end due to point load of 1 kN i.e., 1000 N

$\theta_2 =$  Slope at the free end due to u.d.l. on length BC.

The slope at the free end due to a point load of 1000 N at B is given by equation (13.1 A)

as

$$\theta_1 = \frac{WL^2}{2EI} \quad (\because \theta_B = \theta_1 \text{ here})$$

$$= \frac{1000 \times 2000^2}{2 \times 2.1 \times 10^5 \times 6.667 \times 10^7} = 0.0001428 \text{ rad.}$$

The slope at the free end due to u.d.l. of 2 kN/m over a length of 1 m from the free end is given by equation (13.9) as

$$\theta_2 = \frac{wL^3}{6EI} - \frac{w(L-a)^3}{6EI} \quad (\because \theta_B = \theta_2 \text{ here})$$

$$= \frac{2 \times 2000^3}{6 \times 2.1 \times 10^5 \times 6.667 \times 10^7} - \frac{2 \times (2000 - 1000)^3}{6 \times 2.1 \times 10^5 \times 6.667 \times 10^7}$$

$$= 0.0001904 - 0.000238 = 0.0001666 \text{ rad.}$$

∴ Total slope at the free end

$$= \theta_1 + \theta_2 = 0.0001428 + 0.0001666 = 0.0003094 \text{ rad. Ans.}$$

(ii) Deflection at the free end

Let  $y_1 =$  Deflection at the free end due to point load of 1000 N

$y_2 =$  Deflection at the free end due to u.d.l. on length BC.

The deflection at the free end due to point load of 1000 N is given by equation (13.2 A) as

$$y_1 = \frac{WL^3}{3EI} \quad (\because \text{Here } y_1 = y_B)$$

$$= \frac{1000 \times 2000^3}{3 \times 2.1 \times 10^5 \times 6.667 \times 10^7} = 0.1904 \text{ mm.}$$

The deflection at the free end due to u.d.l. of 2 N/mm over a length of 1 m from the free end is given by equation (13.10) as

$$y_2 = \frac{wL^4}{8EI} - \left[ \frac{w(L-a)^4}{8EI} + \frac{w(L-a)^3}{6EI} \times a \right]$$

$$= \frac{2 \times 2000^4}{8 \times 2.1 \times 10^5 \times 6.667 \times 10^7} - \left[ \frac{2(2000 - 1000)^4}{8 \times 2.1 \times 10^5 \times 6.667 \times 10^7} \right.$$

$$\left. + \frac{2(2000 - 1000)^3 \times 1000}{6 \times 2.1 \times 10^5 \times 6.667 \times 10^7} \right]$$

$$= 0.2857 - [0.01785 + 0.0238] = 0.244 \text{ mm}$$

∴ Total deflection at the free end

$$= y_1 + y_2 = 0.1904 + 0.244 = 0.4344 \text{ mm. Ans.}$$

### 13.7. DEFLECTION OF A CANTILEVER WITH A GRADUALLY VARYING LOAD

A cantilever AB of length  $L$  fixed at the point A and free at the point B and carrying a gradually varying load from 0 at B to  $w$  per unit run at the fixed end A, is shown in Fig. 13.9.

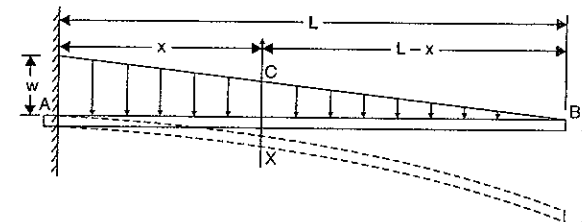

Fig. 13.9

Consider a section X at a distance  $x$  from the fixed end A.

The load at X will be  $\frac{w}{L} (L-x)$  per unit run. Hence vertical height  $XC = \frac{w}{L} (L-x)$ .

Hence the B.M. at this section is given by

$$M_x = - (\text{Load on length } Bx) \times (\text{Distance of C.G. of the load on } Bx \text{ from section } X)$$

$$= - (\text{Area of } \triangle BXC) \times (\text{Distance of C.G. of area } BXC \text{ from } X)$$

(Minus sign is due to hogging)

$$= - \left( \frac{BX \cdot XC}{2} \right) \times \left( \frac{1}{3} \text{ of length } BX \right)$$

$$= - \frac{(L-x)}{2} \cdot \frac{w}{L} (L-x) \times \left[ \frac{1}{3} (L-x) \right] = - \frac{w}{6L} (L-x)^3.$$

But B.M. at any section is also given by equation (12.3) as

$$M = EI \frac{d^2 y}{dx^2}$$

Equating the two values of B.M., we get

$$EI \frac{d^2 y}{dx^2} = - \frac{w}{6L} (L-x)^3$$

Integrating the above equation, we get

$$EI \frac{dy}{dx} = - \frac{w}{6L} \frac{(L-x)^4}{4} (-1) + C_1$$

$$= - \frac{w}{24L} (L-x)^4 + C_1 \quad \dots(i)$$

Integrating again, we get

$$EIy = - \frac{w}{24L} \frac{(L-x)^5}{5} (-1) + C_1 x + C_2$$

$$= - \frac{w}{120L} (L-x)^5 + C_1 x + C_2 \quad \dots(ii)$$

where  $C_1$  and  $C_2$  are constant of integrations. Their values are obtained from boundary conditions, which are :

(i) at  $x = 0, y = 0$  and (ii) at  $x = 0, \frac{dy}{dx} = 0$ .

(i) By substituting  $x = 0$  and  $y = 0$  in equation (ii), we get

$$0 = - \frac{w}{120L} (L-0)^5 + C_1 \times 0 + C_2 \quad \text{or} \quad C_2 = \frac{wL^4}{120}$$

(ii) By substituting  $x = 0$  and  $\frac{dy}{dx} = 0$  in equation (i), we get

$$0 = - \frac{w}{24L} (L-0)^4 + C_1$$

$$\therefore C_1 = - \frac{wL^4}{24L} = - \frac{wL^3}{24}$$

Substituting the values of  $C_1$  and  $C_2$  in equations (i) and (ii), we get

$$EI \frac{dy}{dx} = \frac{w}{24L} (L-x)^4 - \frac{wL^3}{24} \quad \dots(iii)$$

and

$$EIy = - \frac{w}{120L} (L-x)^5 - \frac{wL^3}{24} x + \frac{wL^4}{120} \quad \dots(iv)$$

The equation (iii) is known as *slope equation* and equation (iv) as *deflection equation*. The slope and deflection at the free end (i.e., point B) can be obtained by substituting  $x = L$  in these equations.

Let  $\theta_B =$  Slope at the free end B i.e.,  $\left( \frac{dy}{dx} \right)$  at B and

$y_B =$  Deflection at the free end B.

(a) Substituting  $x = L$  and  $\frac{dy}{dx} = \theta_B$  in equation (iii), we get

$$EI \theta_B = \frac{w}{24L} (L-L)^4 - \frac{wL^3}{24} = - \frac{wL^3}{24}$$

$$\therefore \theta_B = - \frac{wL^3}{24EI} \text{ radians.} \quad \dots(13.11)$$

(b) Substituting  $x = L$  and  $y = y_B$  in equation (iv), we get

$$EI y_B = - \frac{w}{120L} (L-L)^5 - \frac{wL^3}{24} \cdot L + \frac{wL^4}{120}$$

$$= 0 - \frac{wL^4}{24} + \frac{wL^4}{120} = - \frac{5wL^4 + wL^4}{120} = - \frac{wL^4}{30}$$

$$\therefore y_B = - \frac{wL^4}{30EI} \quad (\text{Minus sign means downward deflection})$$

$\therefore$  Downward deflection of B is given by

$$y_B = \frac{wL^4}{30EI} \quad \dots(13.12)$$

**Problem 13.10.** A cantilever of length 4 m carries a uniformly varying load of zero intensity at the free end, and 50 kN/m at the fixed end.

If  $E = 2.0 \times 10^5 \text{ N/mm}^2$  and  $I = 10^8 \text{ mm}^4$ , find the slope and deflection at the free end.

**Sol. Given :**

Length,  $L = 4 \text{ m} = 4000 \text{ mm}$

Load at fixed end,  $w = 50 \text{ kN/m} = \frac{50 \times 1000}{1000} = 50 \text{ N/mm}$

Value of  $E = 2 \times 10^5 \text{ N/mm}^2$

Value of  $I = 10^8 \text{ mm}^4$

Let  $\theta_B =$  Slope at the free end and

$y_B =$  Deflection at the free end.

(i) Using equation (13.11), we get

$$\theta_B = - \frac{wL^3}{24EI} = - \frac{50 \times (4000)^3}{24 \times 2 \times 10^5 \times 10^8} = \mathbf{0.00667 \text{ rad. Ans.}}$$

(ii) Using equation (13.12), we get

$$y_B = \frac{wL^4}{30EI} = \frac{50 \times (4000)^4}{30 \times 2 \times 10^5 \times 10^8} = \mathbf{21.33 \text{ mm. Ans.}}$$

**Problem 13.11.** A cantilever of length 2 m carries a uniformly varying load of 25 kN/m at the free end to 75 kN/m at the fixed end. If  $E = 1 \times 10^5 \text{ N/mm}^2$  and  $I = 10^8 \text{ mm}^4$ , determine the slope and deflection of the cantilever at the free end.

**Sol. Given :**

Length,  $L = 2 \text{ m} = 2000 \text{ mm}$

Load at the free end  $= 25 \text{ kN/m} = \frac{25 \times 1000}{1000} = 25 \text{ N/mm}$

$$\begin{aligned} \text{Load at fixed end} &= 75 \text{ kN/m} = 75 \text{ N/mm} \\ \text{Value of } E &= 1 \times 10^5 \text{ N/mm}^2 \\ \text{Value of } I &= 10^8 \text{ mm}^4. \end{aligned}$$

The load acting on the cantilever is shown in Fig. 13.10. This load is equivalent to a uniformly distributed load of 25 kN/m (or 25 N/mm) over the entire length and a triangular load of zero intensity at free end and  $(75 - 25 = 50 \text{ kN/m}$  or  $50 \text{ N/mm}$ ) 50 N/mm at the fixed end.

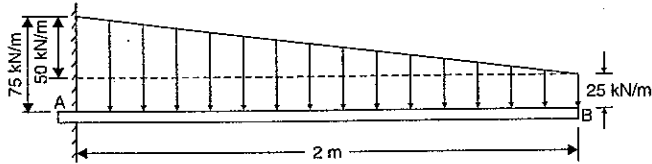

Fig. 13.10

(i) Slope at the free end

Let  $\theta_1$  = Slope at free end due to u.d.l. of 25 N/mm

$\theta_2$  = Slope at free end due to triangular load of intensity 50 N/mm at fixed end.

The slope at the free end due to u.d.l. of 25 N/mm (i.e.,  $w = 25 \text{ N/mm}$ ) is given by equation (13.5) as

$$\begin{aligned} \theta_1 &= \frac{wL^3}{6EI} && \text{(Here } \theta_1 = \theta_B, \text{ and } w = 25) \\ &= \frac{25 \times 2000^3}{6 \times 1 \times 10^5 \times 10^8} = 0.0033 \text{ rad.} \end{aligned}$$

The slope at the free end due to triangular load of intensity of 50 N/mm (i.e.  $w = 50 \text{ N/mm}$ ) is given by equation (13.11) as

$$\begin{aligned} \theta_2 &= \frac{wL^3}{24EI} \\ &= \frac{50 \times 2000^3}{24 \times 1 \times 10^5 \times 10^8} && \text{(Here } w = 50 \text{ N/mm)} \\ &= 0.00167 \text{ rad.} \end{aligned}$$

$$\begin{aligned} \therefore \text{ Total slope at the free end} \\ &= \theta_1 + \theta_2 = 0.0033 + 0.00167 = \mathbf{0.00497. \text{ Ans.}} \end{aligned}$$

(ii) Deflection at the free end

Let  $y_1$  = Deflection at the free end due to u.d.l. of 25 N/mm

$y_2$  = Deflection at the free end due to triangular load.

Using equation (13.11), we get deflection at the free end due to u.d.l.

$$\therefore y_1 = \frac{wL^4}{8EI} = \frac{25 \times 2000^4}{8 \times 1 \times 10^5 \times 10^8} = 5 \text{ mm}$$

Using equation (13.12), we get deflection at the free end to uniformly varying load of zero at the free end and 50 N/mm at the fixed end.

$$\therefore y_2 = \frac{wL^4}{30EI} = \frac{50 \times 2000^4}{30 \times 1 \times 10^5 \times 10^8} = 2.67 \text{ mm}$$

$$\begin{aligned} \therefore \text{ Total deflection at the free end} \\ &= y_1 + y_2 = 5 + 2.67 = \mathbf{7.67 \text{ mm. \text{ Ans.}}} \end{aligned}$$

### 13.8. DEFLECTION AND SLOPE OF A CANTILEVER BY MOMENT AREA METHOD

The moment area method is discussed in Art. 12.8, where this method was applied to a simply supported beam. Let us apply this method to a cantilever. According to this method the change of slope between any two points is equal to the net area of the B.M. diagram between these two points divided by  $EI$ . If one of the points is having zero slope, then we can obtain the slope at the other point.

Similarly if the deflection at a point A is zero, then the deflection at the point B according to this method is given by

$$y = \frac{A\bar{x}}{EI}$$

where  $A$  = Area of B.M. diagram between A and B, and

$\bar{x}$  = Distance of C.G. of the area A from B.

**13.8.1. Cantilever Carrying a Point Load at the Free end.** Fig. 13.11 (a) shows a cantilever of length  $L$  fixed at end A and free at the end B. It carries a point load  $W$  at B.

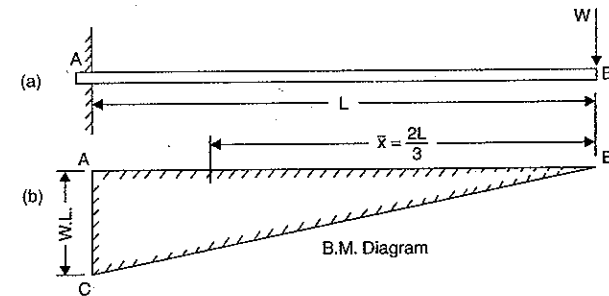

Fig. 13.11

The B.M. will be zero at B and will be  $WL$  at A. The variation of B.M. between A and B is linear as shown in Fig. 13.11 (b).

At the fixed end A, the slope and deflection are zero.

Let  $\theta_B$  = Slope at B i.e.,  $\left(\frac{dy}{dx}\right)$  at B and

$y_B$  = Deflection at B

Then according to moment area method,

$$\begin{aligned} \theta_B &= \frac{\text{Area of B.M. Diagram between A and B}}{EI} \\ &= \frac{\frac{1}{2} \times AB \times AC}{EI} && \text{(Area of triangle ABC)} \\ &= \frac{\frac{1}{2} \times L \times W \cdot L}{EI} = \frac{WL^2}{2EI} \end{aligned}$$

and 
$$y_B = \frac{A\bar{x}}{EI} \quad \dots(i)$$

where  $A = \text{Area of B.M. diagram between A and B} = \frac{W \cdot L^2}{2}$

$\bar{x} = \text{Distance of C.G. of area of B.M. diagram from B} = \frac{2L}{3}$

$$y_B = \frac{\frac{W \cdot L^2}{2} \times \frac{2L}{3}}{EI} = \frac{W \cdot L^3}{3EI}$$

**13.8.2. Cantilever Carrying a Uniformly Distributed load.** Fig. 13.12 (a) shows a cantilever of length  $L$  fixed at end  $A$  and free at the end  $B$ . It carries a uniformly distributed load of  $w/\text{unit length}$  over the entire length.

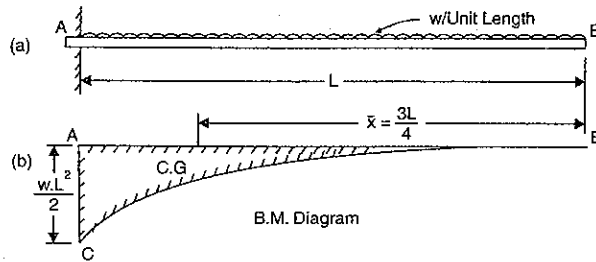

Fig. 13.12

The B.M. will be zero at  $B$  and will be  $\frac{w \cdot L^2}{2}$  at  $A$ . The variation of B.M. between  $A$  and  $B$  is parabolic as shown in Fig. 13.12 (b). At the fixed end  $A$ , the slope and deflection are zero.

Area of B.M. diagram (ABC),  $A = \frac{1}{3} \cdot L \cdot \frac{w \cdot L^2}{2} = \frac{w \cdot L^3}{6}$

and the distance of the C.G. of the B.M. diagram from  $B$ ,

$$\bar{x} = \frac{3L}{4}$$

Let  $\theta_B = \text{Slope at B, i.e., } \left(\frac{dy}{dx}\right)$  and at  $B$

$y_B = \text{Deflection at B.}$

Then according to moment area method,

$$\theta_B = \frac{\text{Area of B.M. diagram}}{EI} = \frac{wL^3}{6EI}$$

$$y_B = \frac{A\bar{x}}{EI} = \frac{w \cdot L^3}{6EI} \times \frac{3L}{4} = \frac{w \cdot L^4}{8EI}$$

and

**13.8.3. Cantilever Carrying a Uniformly Distributed Load upto a Length 'a' from the Fixed end.** Fig. 13.13 (a) shows a cantilever of length  $L$  fixed at end  $A$  and free at the end  $B$ . It carries a uniformly distributed load of  $w/\text{unit length}$  over a length 'a' from the fixed end.

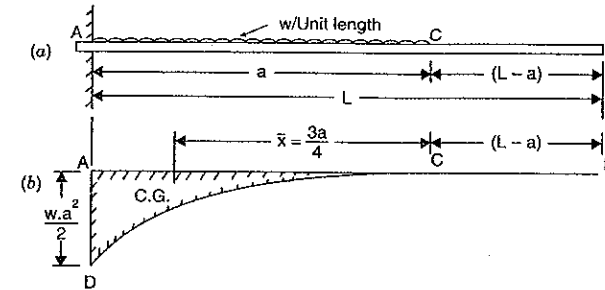

Fig. 13.13

The B.M. will be zero at  $B$  and  $C$ . But B.M. at  $A$  will be  $\frac{w \cdot a^2}{2}$ . The variation of B.M. between  $C$  and  $A$  will be parabolic as shown in Fig. 13.13 (b). At the fixed end the slope and deflection are zero.

Area of B.M. diagram  $A = \frac{1}{3} \cdot a \cdot \frac{w \cdot a^2}{2} = \frac{w \cdot a^3}{6}$

and the distance of the C.G. of B.M. diagram from  $B$ ,

$$\bar{x} = (L - a) + \frac{3a}{4}$$

Let  $\theta_B = \text{Slope at B i.e., } \left(\frac{dy}{dx}\right)$  at  $B$  and

$y_B = \text{Deflection at B.}$

Then according to moment area method,

$$\theta_B = \frac{A}{EI} = \frac{w \cdot a^3}{6EI}$$

and

$$y_B = \frac{A\bar{x}}{EI} = \frac{w \cdot a^3}{6EI} \times \left[ (L - a) + \frac{3a}{4} \right] = \frac{w \cdot a^3}{6EI} (L - a) + \frac{w \cdot a^4}{8EI}$$

**Problem 13.12.** A cantilever of length 2 m carries a point load of 20 kN at the free end and another load of 20 kN at its centre. If  $E = 10^5 \text{ N/mm}^2$  and  $I = 10^8 \text{ mm}^4$  for the cantilever then determine by moment area method, the slope and deflection of the cantilever at the free end.

**Sol. Given :**

Length,  $L = 2 \text{ m}$

Load at free end,  $W_1 = 20 \text{ kN} = 20000 \text{ N}$

Load at centre,  $W_2 = 20 \text{ kN} = 20000 \text{ N}$

Value of  $E = 10^5 \text{ N/mm}^2$

Value of  $I = 10^8 \text{ mm}^4$

First draw the B.M. diagram,

B.M. at  $B = 0$

B.M. at  $C = -20 \times 1 = -20 \text{ kNm} = -20 \times 10^3 \times 10^3 \text{ Nmm}$

$$\text{B.M. at A} = -20 \times 1 - 20 \times 2 = -60 \text{ kNm} = -60 \times 10^3 \times 10^3 \text{ Nmm}$$

B.M. diagram is shown in Fig. 13.14 (b).

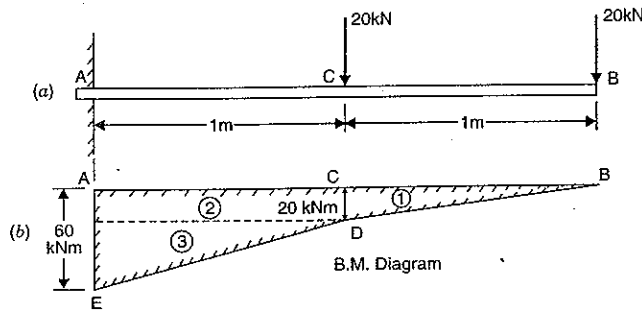

Fig. 13.14

To find the area of B.M. diagram, divide the Fig. 13.14 (b) into two triangles and one rectangle.

$$\begin{aligned} \text{Now area } A_1 &= \frac{1}{2} \times CD \times BC = \frac{1}{2} \times 20 \times 1 \\ &= 10 \text{ kNm}^2 = 10 \times 10^3 \times 10^6 \text{ Nmm}^2 \quad (\because \text{m}^2 = 10^6 \text{ mm}^2) \\ &= 10^{10} \text{ Nmm}^2 \end{aligned}$$

$$\text{Similarly area } A_2 = CD \times AC = 20 \times 1 = 20 \text{ kNm}^2$$

$$\text{and area } A_3 = \frac{1}{2} \times FD \times EF = \frac{1}{2} \times 1 \times 40 = 20 \text{ kNm}^2$$

$\therefore$  Total area of B.M. diagram,

$$\begin{aligned} A &= A_1 + A_2 + A_3 = 10 + 20 + 20 = 50 \text{ kNm}^2 \\ &= 50 \times 10^3 \times 10^6 \text{ Nmm}^2 \quad (\because \text{m}^2 = 10^6 \text{ mm}^2) \end{aligned}$$

Slope and deflection at the fixed end is zero.

Let  $\theta_B =$  Slope at the free end B.

Then according to the moment area method,

$$\begin{aligned} \theta_B &= \frac{\text{Area of B.M. diagram}}{EI} \\ &= \frac{50 \times 10^3 \times 10^6}{10^5 \times 10^8} = 0.005 \text{ radians. Ans.} \end{aligned}$$

Let  $y_B =$  Deflection at the free end B.

Then according to moment area method,

$$y_B = \frac{A\bar{x}}{EI} \quad \dots(i)$$

Now let us find  $\bar{x}$  or  $A\bar{x}$ .

Then total moment of the bending moment diagram about B is given by

$$\begin{aligned} A \cdot \bar{x} &= A_1\bar{x}_1 + A_2\bar{x}_2 + A_3\bar{x}_3 \\ &= 10 \times \left(\frac{2}{3} \times 1\right) + 20 \times \left(1 + \frac{1}{2}\right) + 20 \times \left(1 + \frac{2}{3} \times 1\right) \end{aligned}$$

$$\begin{aligned} &= \frac{20}{3} + 30 + \frac{100}{3} = 70 \text{ kNm}^3 \\ &= 70 \times 10^3 \times 10^9 \text{ Nmm}^3 \quad (\because \text{m}^3 = 10^9 \text{ mm}^3) \\ &= 7 \times 10^{13} \text{ Nmm}^3 \end{aligned}$$

Substituting this value in equation (i), we get

$$y_B = \frac{7 \times 10^{13}}{10^5 \times 10^8} = 7 \text{ mm. Ans.}$$

### HIGHLIGHTS

- The slope i.e.,  $\frac{dy}{dx}$  or  $\theta$  of a cantilever at the free end is given by,

$$\theta_B = \frac{WL^2}{2EI} \quad \text{when the point load is at the free end}$$

$$\theta_B = \theta_C = \frac{W\alpha^2}{2EI} \quad \text{when the point load is at a distance of 'a' from the fixed end}$$

$$\theta_B = \frac{w \cdot L^2}{6EI} \quad \text{when it carries a uniformly distributed load over the whole length.}$$

$$\theta_B = \theta_C = \frac{w\alpha^3}{6EI} \quad \text{when it carries a uniformly distributed load over a length 'a' from the fixed end.}$$

$$\theta_B = \frac{w \cdot L^3}{6EI} - \frac{w \cdot (L - \alpha)^3}{6EI} \quad \text{when it carries a uniformly distributed load over a distance 'a' from the free end}$$

$$\theta_B = \frac{w \cdot L^3}{24EI} \quad \text{when it carries a gradually varying load from zero at the free end to } w/\text{m run at fixed end.}$$

where  $W =$  Point load,

$w =$  Uniformly distributed load,

$L =$  Length of beam,

$I =$  Moment of inertia, and

$E =$  Young's modulus.

- The deflection i.e.,  $y$  of a cantilever of length  $L$ , at the free end is given by,

$$y_B = \frac{WL^3}{3EI} \quad \text{when the point load is at the free end}$$

$$y_B = \frac{W\alpha^3}{3EI} + \frac{W\alpha^2}{2EI} (L - \alpha) \quad \text{when the point load is at a distance of 'a' from the fixed end}$$

$$y_B = \frac{wL^4}{8EI} \quad \text{when it carries a uniformly distributed load over the whole length}$$

$$y_B = \frac{w\alpha^4}{8EI} + \frac{w \cdot \alpha^3}{6EI} (L - \alpha) \quad \text{when it carries a uniformly distributed load over a length 'a' from the fixed end.}$$

$$= \frac{W \cdot b}{W \cdot a \cdot b} (L^2 - b^2) \cdot a - \left( \frac{1}{2} \times a \times \frac{EIL}{W \cdot a \cdot b} \right) \times \left( \frac{3}{a} \right) = \frac{6EIL}{W \cdot a \cdot b} (L^2 - b^2) - \frac{6EIL}{W \cdot a \cdot b} (L^2 - b^2) - \frac{6EIL}{W \cdot a \cdot b} [L^2 - b^2 - a^2]$$

**Problem 14.1.** A simply supported beam of length 5 m carries a point load of 5 kN at a distance of 3 m from the left end. If  $E = 2 \times 10^5 \text{ N/mm}^2$  and  $I = 10^8 \text{ mm}^4$ , determine the slope at the left support and deflection under the point load using conjugate beam method.

**Sol. Given :**

Length,  $L = 5 \text{ m}$   
 Point load,  $W = 5 \text{ kN}$   
 Distance AC,  $a = 3 \text{ m}$   
 Distance BC,  $b = 5 - 3 = 2 \text{ m}$   
 Value of  $E = 2 \times 10^5 \text{ N/mm}^2 = 2 \times 10^6 \text{ N/m}^2$   
 Value of  $I = 1 \times 10^8 \text{ mm}^4 = 10^{-4} \text{ m}^4$

and

Let  $R_A = \text{Reaction at A}$   
 $R_B = \text{Reaction at B}$   
 Taking moments about A, we get

$$R_B \times 5 = 5 \times 3$$

$$R_B = \frac{5}{5} \times 3 = 3 \text{ kN}$$

$$R_A = \text{Total load} - R_B = 5 - 3 = 2 \text{ kN}$$

and

The B.M. at A = 0

B.M. at B = 0

$$\text{B.M. at C} = R_A \times 3 = 2 \times 3 = 6 \text{ kNm.}$$

Now B.M. diagram is drawn as shown in Fig. 14.3 (b).

Now construct the conjugate beam as shown in Fig. 14.3 (c). The vertical load at C\* on

conjugate beam

$$\text{B.M. at C} = \frac{EI}{6 \text{ kNm}} = \frac{EI}{6}$$

Now calculate the reaction at A\* and B\* for conjugate beam

Let  $R_A^* = \text{Reaction at A}^*$  for conjugate beam

$R_B^* = \text{Reaction at B}^*$  for conjugate beam.

Taking moments about A\*, we get

$$R_B^* \times 5 = \text{Load on A}^*C^*D^* \times \text{distance of C.G. of A}^*C^*D^* \text{ from A}^* + \text{Load on B}^*C^*D^* \times \text{Distance of C.G. of B}^*C^*D^* \text{ from A}^*$$

$$= \left( \frac{1}{2} \times 3 \times \frac{EI}{6} \right) \times \left( \frac{3}{2} \times 3 \right) + \left( \frac{1}{2} \times 2 \times \frac{EI}{6} \right) \times \left( 3 + \frac{3}{2} \times 2 \right)$$

$$= \frac{18}{40} \times \frac{EI}{6} + \frac{EI}{11} \times \frac{3}{8} = \frac{3EI}{8} + \frac{3EI}{22} = \frac{EI}{8} + \frac{EI}{22} = \frac{EI}{40}$$

$$R_B^* = \frac{40}{1} \times \frac{EI}{5} = \frac{8EI}{5}$$

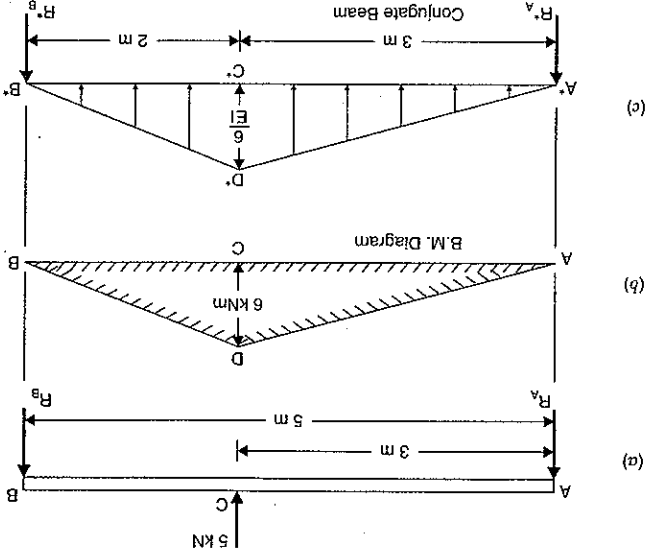

Fig. 14.3

$$R_A^* = \text{Total load (i.e., load A}^*B^*D^*) - R_B^*$$

$$= \left( \frac{1}{2} \times 5 \times \frac{EI}{6} \right) - \frac{EI}{8}$$

$$= \frac{15}{8} \frac{EI}{6} - \frac{EI}{8} = \frac{EI}{8}$$

Let  $\theta_A = \text{Slope at A for the given beam i.e., } \left( \frac{dy}{dx} \right) \text{ at A}$   
 $\gamma_C = \text{Deflection at C for the given beam}$   
 Then according to conjugate beam method,

$$\theta_A = \text{Shear force at A}^* \text{ for conjugate beam} = R_A^*$$

$$\frac{EI}{7} = \frac{2 \times 10^6 \times 10^{-4}}{7} \quad (\because E = 2 \times 10^6 \text{ kN/m}^2 \text{ and } I = 10^{-4} \text{ m}^4)$$

$$= 0.00035 \text{ radians. Ans.}$$

$\gamma_C = \text{B.M. at C}^*$  for conjugate beam

$$= R_A^* \times 3 - \text{Load A}^*C^*D^* \times \text{Distance of C.G. of A}^*C^*D^* \text{ from C}^*$$

$$= \frac{EI}{7} \times 3 - \left( \frac{1}{2} \times 3 \times \frac{EI}{6} \right) \times \left( \frac{3}{2} \times 3 \right)$$

$$= \frac{21}{12} \frac{EI}{9} - \frac{EI}{12}$$

$$= \frac{2 \times 10^6 \times 10^{-4}}{12} = \frac{10^4}{6} \text{ m} = \frac{10000}{6 \times 1000} \text{ mm} = 0.6 \text{ mm. Ans.}$$



Construct now the conjugate beam. The load at any point on the conjugate beam will be equal to B.M. at that point divided by  $EI$ . Fig. 14.2 (c) shows the conjugate beam with the loads. The vertical load on conjugate beam at  $C^*$  will be  $\frac{M}{W \cdot a \cdot b} = \frac{L \times EI}{EI \cdot L}$ .

Let  $R_A^*$  = Reaction at  $A$  for conjugate beam

$R_B^*$  = Reaction at  $B$  for conjugate beam

Taking moments about  $A$  of the conjugate beam, we get

$R_B^* \cdot L$  = Load  $AC^*D^*$   $\times$  Distance of C.G., of  $AC^*D^*$  from  $A$  + Load  $BC^*D^*$   $\times$  Distance of C.G., of  $BC^*D^*$  from  $A$

$$= \left( \frac{2}{1} \times AC^* \times C^*D^* \right) \times \left( \frac{1}{2} \cdot BC^* \cdot C^*D^* \right) \times \left( AC^* + \frac{3}{1} \times BC^* \right)$$

$$= \left( \frac{2}{1} \times a \times \frac{EI \cdot L}{W \cdot a \cdot b} \right) \times \left( \frac{3}{2} \times a \right) + \left( \frac{2}{1} \times b \times \frac{EI \cdot L}{W \cdot a \cdot b} \right) \times \left( a \times \frac{3}{b} \right)$$

$$= \frac{W \cdot a^3 \cdot b}{3EI} + \frac{2EI}{3EI} \left( a + \frac{3}{b} \right)$$

$$= \frac{W \cdot a^3 \cdot b}{3EI} + \frac{2EI}{2EI} + \frac{6EI}{W \cdot a \cdot b^3}$$

$$= \frac{W \cdot a \cdot b}{6EI} [2a^2 + 3ab + b^2]$$

$$= \frac{W \cdot a \cdot b}{6EI} (a^2 + b^2 + 2ab + a^2 + ab)$$

$$= \frac{W \cdot a \cdot b}{6EI} [(a + b)^2 + a(a + b)]$$

$$= \frac{W \cdot a \cdot b}{6EI} [L^2 + a \cdot L]$$

$\therefore a + b = L$

$$= \frac{6EI}{W \cdot a} [L(L + a)] = \frac{6EI}{W \cdot a} [L^2 - a^2]$$

$$\therefore R_B^* = \frac{W \cdot a}{6EI} (L^2 - a^2)$$

Similarly the reaction at  $A$  can be obtained as

$$R_A^* = \frac{6EI}{W \cdot b} (L^2 - b^2)$$

Let  $\theta_A$  = Slope at  $A$  for the given beam i.e.,  $\left( \frac{dy}{dx} \right)$  at  $A$

$y_C$  = Deflection at  $C$  for the given beam.

Then according to conjugate beam method,

$\theta_A$  = Shear force at  $A$  for the conjugate beam

$$= R_A^*$$

$\therefore$  S.F. at  $A$  for conjugate beam =  $R_A^*$

$y_C$  = B.M. at  $C$  for conjugate beam

$$= \frac{6EI}{W \cdot b} (L^2 - b^2)$$

$= R_A^* \cdot a$  - Load  $AC^*D^*$   $\times$  Distance of C.G. of  $AC^*D^*$  from  $C$

[See Fig. 14.2 (c)]

$$= R_A^* \quad \therefore \text{S.F. at } A \text{ for conjugate beam} = R_A^*$$

$$= \frac{WL^2}{6EI}$$

$$y_C = \text{B.M. at } C \text{ for the conjugate beam}$$

[See Fig. 14.1 (c)]

$$= R_A^* \times \frac{L}{2} - \text{Load corresponding to } AC^*D^*$$

$$\times \text{Distance of C.G. of } AC^*D^* \text{ from } C$$

$$= \frac{16EI}{L} \cdot \frac{L}{2} - \left( \frac{2}{1} \times \frac{L}{2} \times \frac{4EI}{WL} \right) \times \left( \frac{1}{3} \times \frac{L}{2} \right)$$

$$= \frac{16EI}{L} \cdot \frac{L}{2} - \frac{32EI}{3WL} = \frac{32EI}{3WL} - \frac{32EI}{3WL} = \frac{16EI}{48EI}$$

14.4. SIMPLY SUPPORTED BEAM CARRYING AN ECCENTRIC POINT LOAD

Fig. 14.2 (a) shows a beam  $AB$  of length  $L$ , simply supported at  $A$  and  $B$  and carrying a point load of  $W$  at a distance  $a$  from the end  $A$ . The reactions at  $A$  and  $B$  are given by

$$R_A = \frac{W \cdot b}{L} \quad \text{and} \quad R_B = \frac{L}{W \cdot a}$$

The B.M. will be zero at  $A$  and  $B$ . At  $C$ , the B.M. will be  $R_A \times a = \frac{L}{W \cdot b} \times a = \frac{L}{W \cdot b \cdot a} = \frac{L}{W \cdot a \cdot b}$ . Now the B.M. diagram can be drawn as shown in Fig. 14.2 (b).

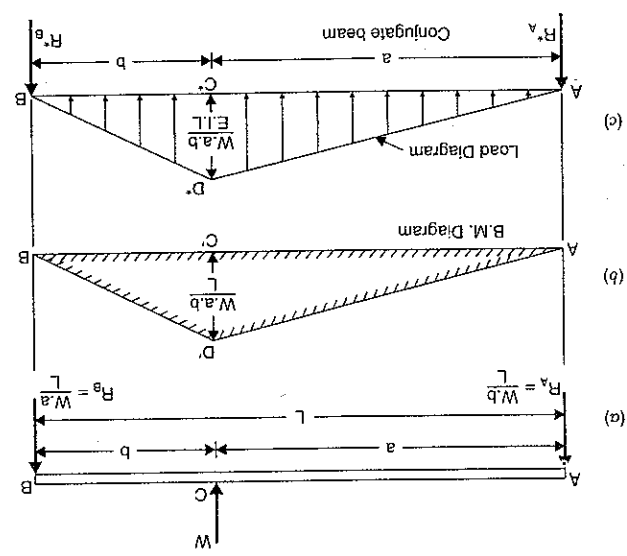

Fig. 14.2

and

# Conjugate Beam Method, Propped Cantilevers and Beams

## 14.1. INTRODUCTION

The slopes and deflections of beams and cantilevers may be obtained from various methods like double integration method, moment area method, Macaulay's method, etc. But these methods become laborious, when applied to beams whose flexural rigidity (*i.e.*, the product of *E* and *I* is known as flexural rigidity) is not uniform throughout the length of the beam. The slopes and deflections of such beams can be easily obtained by conjugate beam method.

## 14.2. CONJUGATE BEAM METHOD

Before describing the conjugate beam method, let us first define conjugate beam.

Conjugate beam is an imaginary beam of length equal to that of the original beam but for which the load diagram is the  $\frac{M}{EI}$  diagram\* (*i.e.*, the load at any point on the conjugate beam is equal to B.M. at that point divided by *EI*).

The slopes and deflection at any section of a beam by conjugate beam method is given by :

1. The slope at any section of the given beam is equal to the shear force at the corresponding section of the conjugate beam.
2. The deflection at any section for the given beam is equal to the bending moment at the corresponding section of the conjugate beam.

Hence before applying the conjugate beam method, conjugate beam is constructed. The load on the conjugate beam at any point is equal to the B.M. at that point divided by *EI*. Hence the loading on the conjugate beam is known. Then the shear force at any point on the conjugate beam gives the slope at the corresponding point of actual beam. And the B.M. at any point on the conjugate beam gives the deflection at the corresponding point of the actual beam.

## 14.3. DEFLECTION AND SLOPE OF A SIMPLY SUPPORTED BEAM WITH A POINT LOAD AT THE CENTRE

Fig. 14.1 (a) shows a simply supported beam *AB* of length *L* carrying a point load *W* at the centre *C*. The B.M. at *A* and *B* is zero and at the centre B.M. will be  $W \cdot L/4$ . The B.M. varies according to straight line law. The B.M. diagram is shown in Fig. 14.1 (b). Now the conjugate beam *AB* can be constructed. The load on the conjugate beam will be obtained by  $M/EI$  diagram is a diagram which shows the variation of  $M/EI$  over the length of the beam.

dividing the B.M. at that point by *EI*. The shape of loading on the conjugate beam will be same as of B.M. diagram. The ordinate of loading on conjugate beam will be equal to  $\frac{M}{EI} = \frac{W \times L}{EI} \left( \frac{4}{L} \right) = \frac{4EI}{W \times L}$ . Hence ordinate at the centre will be  $\frac{4EI}{W \cdot L}$  as shown in Fig. 14.1 (c). The load diagram for conjugate beam is shown in Fig. 14.1 (c).

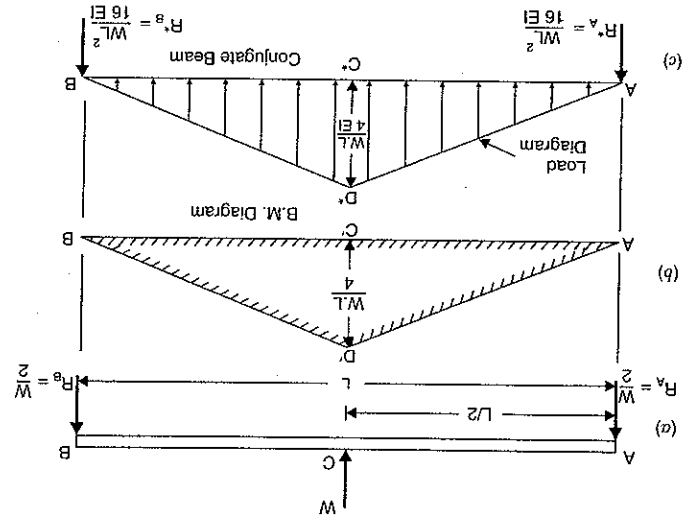

Fig. 14.1

Let  $R_A^*$  = Reaction at *A* for conjugate beam

$R_B^*$  = Reaction at *B* for conjugate beam

Total load on the conjugate beam [See Fig. 14.1 (c)]

= Area of the load diagram

$$= \frac{1}{2} \times AB \times C^*D^* = \frac{1}{2} \times L \times \frac{4EI}{WL}$$

$$= \frac{WL^2}{8EI}$$

Reaction at each support for the conjugate beam will be half of the total load

$$R_A^* = R_B^* = \frac{1}{2} \times \frac{WL^2}{8EI} = \frac{WL^2}{16EI}$$

Let  $\theta_A$  = Slope at *A* for the given beam *i.e.*,  $\left( \frac{dy}{dx} \right)$  at *A*

$y_c$  = deflection at *C* for the given beam.

Then according to conjugate beam method,

$$\theta_A = \text{Shear force at } A \text{ for the conjugate beam}$$

$$y_B = \frac{wL^4}{24EI} - \left[ \frac{8EI}{L} \omega(L-a)^3 + \frac{8EI}{L} \omega(L-a)^4 + \frac{6EI}{L} \omega \times a \right]$$

when it carries a uniformly distributed load over a length 'a' from the free end

$$y_B = \frac{wL^4}{30EI}$$

when it carries a gradually varying load from zero at the free end to  $w/m$  run at the fixed end.

3. For a cantilever, at the fixed end slope and deflections are zero. Hence moment area method can be easily applied for finding slope and deflections of cantilevers. The slope ( $\theta_B$ ) and deflection ( $y_B$ ) at the free end is given by,

$$\theta_B = \frac{\text{Area of B.M. diagram between free end and fixed end}}{EI}$$

and

$$y_B = \frac{A\bar{x}}{EI}$$

where A = Area of B.M. Diagram and

 $\bar{x}$  = Distance of C.G. of B.M. diagram from free end.

4. Area of B.M. diagram sometimes is found easily by splitting the combined areas into triangles and rectangles.

**(A) Theoretical Questions**

1. What is a cantilever? What are the different methods of finding of slope and deflection of a cantilever?

2. Derive an expression for the slope and deflection of a cantilever of length L, carrying a point load W at the free end by double integration method.

3. Solve question 2, by moment area method.

4. Prove that the slope and deflection of a cantilever carrying uniformly distributed load over the whole length are given by,

$$\theta_B = \frac{wL^3}{6EI} \quad \text{and} \quad y_B = \frac{wL^4}{8EI}$$

where  $w$  = Uniformly distributed load and $EI$  = Flexural rigidity.

5. Find the expression for the slope and deflection of a cantilever of length L which carries a uniformly distributed load over a length 'a' from the fixed end by

- (i) Double integration method and

- (ii) Moment area method.

6. Prove that the slope and deflection of a cantilever length L, which carries a gradually varying load from zero at the free end to  $w/m$  run at the fixed end are given by:

$$\theta_B = \frac{wL^3}{24EI} \quad \text{and} \quad y_B = \frac{wL^4}{30EI}$$

where  $EI$  = Flexural rigidity.**(B) Numerical Problems**

1. A cantilever of length 2 m carries a point load of 30 kN at the free end. If moment of inertia  $I = 10^8 \text{ mm}^4$  and value of  $E = 2 \times 10^5 \text{ N/mm}^2$ , then find:

(i) slope of the cantilever at the free end and

(ii) deflection at the free end.

[Ans. (i) 0.003 rad., (ii) 4 mm]

2. A cantilever of length 3 m carries a point load of 60 kN at a distance of 2 m from the fixed end. If  $E = 2 \times 10^5$  and  $I = 10^8$ , find:

(i) slope at the free end and

(ii) deflection at the free end.

[Ans. 0.006 rad., 14 mm]

3. A cantilever of length 30 m carries a uniformly distributed load of 24 kN/m length over the entire length. If moment of inertia of the beam =  $10^8 \text{ mm}^4$  and value of  $E = 2 \times 10^5 \text{ N/mm}^2$ , determine the slope and deflection at the free end.

4. A cantilever of length 3 m carries a uniformly distributed load over the entire length. If the slope at the free end is 0.01777 radians, find the deflection at the free end.

[Ans. 39.99 mm]

5. Determine the slope and deflection at the free end of a cantilever of length 4 m which is carrying a uniformly distributed load of 12 kN/m over a length of 3 m from the fixed end. Take  $EI = 2 \times 10^{13} \text{ N/mm}^2$ .

[Ans. 0.0027 rad., 8.775 mm]

6. A cantilever of length 3 m carries a uniformly distributed load of 15 kN/m over a length of 2 m from the free end. If  $I = 10^8 \text{ mm}^4$  and  $E = 2 \times 10^5 \text{ N/mm}^2$ , find:

(i) slope at the free end and

(ii) deflection at the free end.

[Ans. 0.00326 rad., 7.25 mm]

7. A cantilever of length 2 m carries a load of 20 kN at the free end and 30 kN at a distance 1 m from the end. Find the slope and deflection at the free end. Take  $E = 2.0 \times 10^5 \text{ N/mm}^2$  and  $I = 1.5 \times 10^8 \text{ mm}^4$ .

[Ans. 0.00183 rad., 2.6 mm]

8. Determine the deflection at the free end of a cantilever which is 2 m long and carries a point load of 9 kN at the free end and a uniformly distributed load of 8 kN/m over a length of 1 m from the fixed end.

[Ans. 6.54 mm]

9. A cantilever of length 2 m carries a uniformly varying load of zero intensity at the free end, and 45 kN/m at the fixed end. If  $E = 2 \times 10^5 \text{ N/mm}^2$  and  $I = 10^8 \text{ mm}^4$ , find the slope and deflection of the free end.

[Ans. 0.00075 rad., 1.2 mm]

10. A cantilever of length 2 m carries a point load of 30 kN at the free end and another load of 30 kN at its centre. If  $EI = 10^{13} \text{ N/mm}^2$  for the cantilever then determine by moment area method, the slope and deflection at the free end of cantilever.

[Ans. 0.0075 rad., 10.50 mm]

11. A cantilever of length 'L' carries a U.D.L. of  $w$  per unit for a length of  $\frac{2}{L}$  from the fixed end. Determine the slope and deflection at the free end using area moment method.

(Bangalore University, 1990)

[Hint. See Article 13.8.3 on page 572. Here  $a = \frac{2}{L}$ . Hence slope at free end,

$$\theta_B = \frac{6EI}{w \times a^3} \times \left( \frac{L}{2} \right) \times \left( \frac{L}{2} \right) \times \frac{6EI}{48EI} = \frac{6EI}{w \times L^3}$$

and deflection at free end,
$$y_B = \frac{6EI}{w \times a^3} (L-a) + \frac{8EI}{w \times a^4}$$

$$= \frac{6EI}{L} \times \left( \frac{L}{2} \right) \times \left( \frac{L}{2} \right) \times \frac{6EI}{48EI} + \frac{8EI}{L^2} \times \frac{L}{2} + \frac{128EI}{w \times L^4}$$

$$= \frac{6EI}{L} \times \frac{L^2}{4} \times \frac{6EI}{48EI} + \frac{128EI}{w \times L^4} = \frac{96}{L} \times \frac{6EI}{48EI} + \frac{128EI}{w \times L^4} = \frac{128 \times 3}{4+3} \times \frac{EI}{w \times L^4}$$

$$= \frac{384}{L} \times \frac{EI}{w \times L^4} = \frac{384}{L^5} \times \frac{EI}{w \times L^4}$$

[Ans.]

**Problem 14.2.** A simply supported beam of length 4 m carries a point load of 3 kN at a distance of 1 m from each end. If  $E = 2 \times 10^5 \text{ N/mm}^2$  and  $I = 10^8 \text{ mm}^4$  for the beam, then using conjugate beam method determine:

- (i) slope at each end and under each load  
 (ii) deflection under each load and at the centre.

**Sol. Given :**

Length,  $L = 4 \text{ m}$   
 Value of  $E = 2 \times 10^5 \text{ N/mm}^2 = 2 \times 10^5 \times 10^6 \text{ N/m}^2$   
 $= 2 \times 10^5 \times 10^3 \text{ kN/m}^2 = 2 \times 10^8 \text{ kN/m}^2$   
 Value of  $I = 10^8 \text{ mm}^4 = \frac{10^8}{10^{12}} \text{ m}^4 = 10^{-4} \text{ m}^4$ .

As the load on the beam is symmetrical as shown in Fig. 14.4 (a), the reactions  $R_A$  and  $R_B$  will be equal to 3 kN.

Now B.M. at A and B are zero.

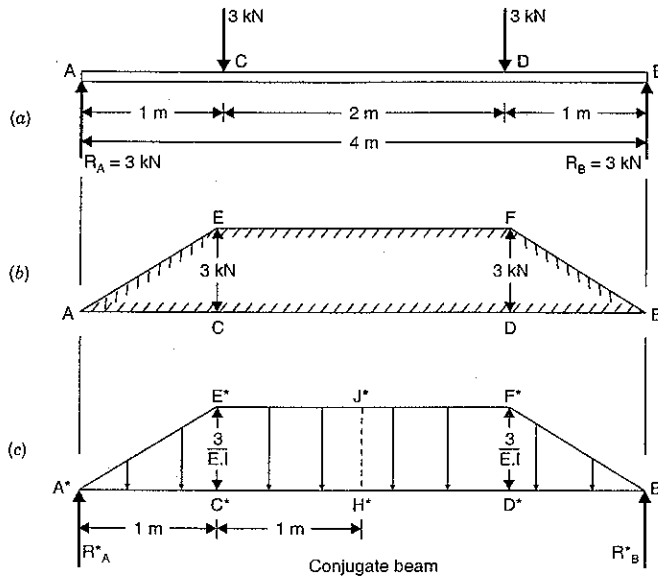

Fig. 14.4

B.M. at C =  $R_A \times 1 = 3 \times 1 = 3 \text{ kNm}$

B.M. at D =  $R_B \times 1 = 3 \times 1 = 3 \text{ kNm}$

Now B.M. diagram can be drawn as shown in Fig. 14.4 (b).

Now by dividing the B.M. at any section by  $EI$ , we can construct the conjugate beam as shown in Fig. 14.4 (c). The loading are shown on the conjugate beam.

Let  $R_{A^*}$  = Reaction at  $A^*$  for the conjugate beam and  
 $R_{B^*}$  = Reaction at  $B^*$  for conjugate beam

The loading on the conjugate beam is symmetrical

$$\begin{aligned} \therefore R_{A^*} &= R_{B^*} = \text{Half of total load on conjugate beam} \\ &= \frac{1}{2} [\text{Area of trapezoidal } A^*B^*F^*E^*] \\ &= \frac{1}{2} \left[ \frac{(E^*F^* + A^*B^*)}{2} \times E^*C^* \right] \\ &= \frac{1}{2} \left[ \frac{(2+4)}{2} \times \frac{3}{EI} \right] = \frac{4.5}{EI} \end{aligned}$$

(i) Slope at each end and under each load

Let  $\theta_A$  = Slope at A for the given beam i.e.,  $\left(\frac{dy}{dx}\right)$  at A  
 $\theta_B$  = Slope at B for the given beam  
 $\theta_C$  = Slope at C for the given beam and  
 $\theta_D$  = Slope at D for the given beam

Then according to conjugate beam method,

$$\begin{aligned} \theta_A &= \text{Shear force at } A^* \text{ for conjugate beam} = R_{A^*} \\ &= \frac{4.5}{EI} = \frac{4.5}{2 \times 10^8 \times 10^{-4}} = 0.000225 \text{ rad. Ans.} \end{aligned}$$

$$\theta_B = R_{B^*} = \frac{4.5}{EI} = 0.000225 \text{ rad. Ans.}$$

$$\begin{aligned} \theta_C &= \text{Shear force at } C^* \text{ for conjugate beam} \\ &= R_{A^*} - \text{Total load } A^*C^*D^* \\ &= \frac{4.5}{EI} - \frac{1}{2} \times 1 \times \frac{3}{EI} = \frac{3}{EI} \\ &= \frac{3}{2 \times 10^8 \times 10^{-4}} = 0.00015 \text{ rad. Ans.} \end{aligned}$$

Similarly,  $\theta_D = 0.00015 \text{ rad. Ans.}$

(By symmetry)

(ii) Deflection under each load

Due to symmetry, the deflection under each load will be equal

Let  $y_C$  = Deflection at C for the given beam and

$y_D$  = Deflection at D for the given beam.

Now according to conjugate beam method,

$$\begin{aligned} y_C &= \text{B.M. at } C^* \text{ for conjugate beam} \\ &= R_{A^*} \times 1.0 - (\text{Load } A^*C^*E^*) \times \text{Distance of C.G. of } A^*C^*E^* \text{ from } C^* \\ &= \frac{4.5}{EI} \times 1 - \left( \frac{1}{2} \times 1 \times \frac{3}{EI} \right) \times \frac{1}{3} \\ &= \frac{4.5}{EI} - \frac{0.5}{EI} = \frac{4.0}{EI} \\ &= \frac{4}{2 \times 10^8 \times 10^{-4}} \text{ m} = \frac{4 \times 1000}{2 \times 10^4} \text{ mm} \\ &= 0.2 \text{ mm. Ans.} \end{aligned}$$

Also  $y_D = 0.2 \text{ mm.}$

Deflection at the centre of the beam

$$\begin{aligned}
 &= \text{B.M. at the centre of the conjugate beam} \\
 &= R_A^* \times 2.0 - \text{Load } A^*C^*E^* \\
 &\quad \times \text{Distance of C.G. of } A^*C^*E^* \text{ from the centre of beam} \\
 &\quad - \text{Load } C^*H^*J^*E^* \\
 &\quad \times \text{Distance of C.G. of } C^*H^*J^*E^* \text{ from the centre of beam} \\
 &= \frac{4.5}{EI} \times 2.0 - \left( \frac{1}{2} \times 1 \times \frac{3}{EI} \right) \times \left( 1 + \frac{1}{3} \right) - \left( 1 \times \frac{3}{EI} \right) \times \frac{1}{2} \\
 &= \frac{9}{EI} - \frac{2}{EI} - \frac{1.5}{EI} = \frac{6.5}{EI} \\
 &= \frac{6.5}{2 \times 10^8 \times 10^{-4}} \text{ m} = \frac{6.5 \times 1000}{2 \times 10^4} \text{ mm} \\
 &= \mathbf{0.325 \text{ mm. Ans.}}
 \end{aligned}$$

**Problem 14.3.** A simply supported beam  $AB$  of span  $4 \text{ m}$  carries a point of  $100 \text{ kN}$  at its centre  $C$ . The value of  $I$  for the left half is  $1 \times 10^8 \text{ mm}^4$  and for the right half portion  $I$  is  $2 \times 10^8 \text{ mm}^4$ . Find the slopes at the two supports and deflection under the load.

Take  $E = 200 \text{ GN/m}^2$ .

**Sol. Given :**

Length,  $L = 4 \text{ m}$   
 Length  $AC = \text{Length } BC = 2 \text{ m}$   
 Point load,  $W = 100 \text{ kN}$   
 Moment of inertia for  $AC$

$$I = 1 \times 10^8 \text{ mm}^4 = \frac{10^8}{10^{12}} \text{ m}^4 = 10^{-4} \text{ m}^4$$

Moment of inertia for  $BC$

$$\begin{aligned}
 &= 2 \times 10^8 \text{ mm}^4 \\
 &= 2 \times 10^{-4} \text{ m}^4 = 2I \quad (\because 10^{-4} = I)
 \end{aligned}$$

Value of  $E = 200 \text{ GN/m}^2 = 200 \times 10^9 \text{ N/m}^2$   
 $= 200 \times 10^6 \text{ kN/m}^2$ .

The reactions at  $A$  and  $B$  will be equal, as point load is acting at the centre.

$$R_A = R_B = \frac{100}{2} = 50 \text{ kN}$$

Now B.M. at  $A$  and  $B$  are zero.

B.M. at  $C = R_A \times 2 = 50 \times 2 = 100 \text{ kNm}$

Now B.M. can be drawn as shown in Fig. 14.5 (b).

Now we can construct the conjugate beam by dividing B.M. at any section by the product of  $E$  and M.O.I.

The conjugate beam is shown in Fig. 14.5 (c). The loading are shown on the conjugate beam. The loading on the length  $A^*C^*$  will be  $A^*C^*D^*$  whereas the loading on length  $B^*C^*$  will be  $B^*C^*E^*$ .

$$\text{The ordinate } C^*D^* = \frac{\text{B.M. at } C}{E \times \text{M.O.I. for } AC} = \frac{100}{EI}$$

$$\text{The ordinate } C^*E^* = \frac{\text{B.M. at } C}{\text{Product of } E \text{ and M.O.I. for } BC} = \frac{100}{E \times 2I} = \frac{50}{EI}$$

Let  $R_A^*$  = Reaction at  $A^*$  for conjugate beam

$R_B^*$  = Reaction at  $B^*$  for conjugate beam

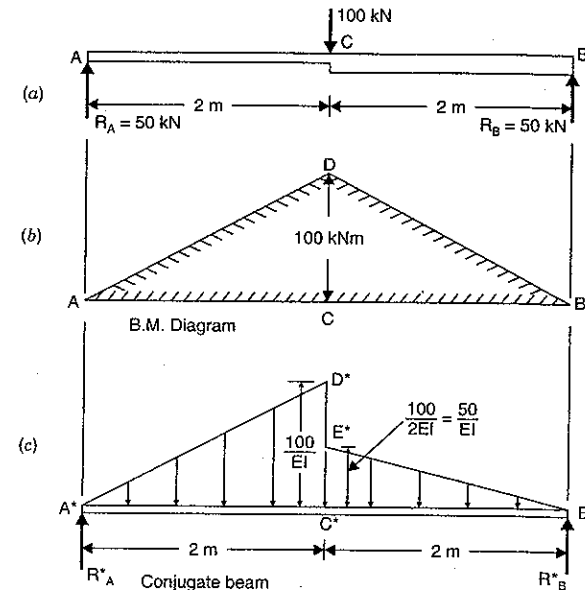

Fig. 14.5

First calculate  $R_A^*$  and  $R_B^*$

Taking moments of all forces about  $A^*$ , we get

$$\begin{aligned}
 R_B^* \times 4 &= \text{Load } A^*C^*D^* \times \text{Distance of C.G. of } A^*C^*D^* \text{ from } A \\
 &\quad + \text{Load } B^*C^*E^* \times \text{Distance of C.G. of } B^*C^*E^* \text{ from } A^* \\
 &= \left( \frac{1}{2} \times 2 \times \frac{100}{EI} \right) \times \left( \frac{2}{3} \times 2 \right) + \left( \frac{1}{2} \times 2 \times \frac{50}{EI} \right) \times \left( 2 + \frac{1}{3} \times 2 \right) \\
 &= \frac{400}{3EI} + \frac{400}{3EI} = \frac{800}{3EI}
 \end{aligned}$$

$$R_B^* = \frac{200}{3EI}$$

and

$$\begin{aligned}
 R_A^* &= \text{Total load on conjugate beam} - R_B^* \\
 &= \left( \frac{1}{2} \times 2 \times \frac{100}{EI} + \frac{1}{2} \times 2 \times \frac{50}{EI} \right) - \frac{200}{3EI} \\
 &= \frac{150}{EI} - \frac{200}{3EI} = \frac{250}{3EI}
 \end{aligned}$$

(i) Slopes at the supports

Let  $\theta_A =$  Slope at A i.e.,  $\left(\frac{dy}{dx}\right)$  at A for the given beam $\theta_B =$  Slope at B i.e.,  $\left(\frac{dy}{dx}\right)$  at B for the given beam

The according to the conjugate beam method,

$$\theta_A = \text{Shear force at } A^* \text{ for conjugate beam} = R_A^*$$

$$= \frac{250}{3EI}$$

$$= \frac{250}{3 \times 200 \times 10^6 \times 10^4} = 0.004166 \text{ rad. Ans.}$$

and

$$\theta_B = \text{Shear force at } B^* \text{ for conjugate beam} = R_B^*$$

$$= \frac{200}{3EI} = \frac{200}{3 \times 200 \times 10^6 \times 10^4} = 0.003333 \text{ rad. Ans.}$$

(ii) Deflection under the load

Let  $y_C =$  Deflection at C for the given beam.

Then according to the conjugate beam method,

 $y_C =$  B.M. at point  $C^*$  of the conjugate beam $= R_A^* \times 2 - (\text{Load } A^*C^*D^*) \times \text{Distance of C.G. of } A^*C^*D^* \text{ from } C^*$ 

$$= \frac{250}{3EI} \times 2 - \left(\frac{1}{2} \times 2 \times \frac{100}{EI}\right) \times \left(\frac{1}{3} \times 2\right)$$

$$= \frac{500}{3EI} - \frac{200}{3EI} = \frac{100}{EI}$$

$$= \frac{100}{200 \times 10^6 \times 10^{-4}} \text{ m}$$

$$= \frac{1}{200} \text{ m} = \frac{1}{200} \times 1000 = 5 \text{ mm. Ans.}$$

**Problem 14.4.** A beam ABCD is simply supported at its ends A and D over a span of 30 metres. It is made up of three portions AB, BC and CD each 10 m in length. The moments of inertia of the section of these portion are I, 3I and 2I respectively, where  $I = 2 \times 10^{10} \text{ mm}^4$ . The beam carries a point load of 150 kN at B and a point load of 300 kN at C. Neglecting the weight of the beam calculate the slopes and deflections at A, B, C and D. Take  $E = 2 \times 10^2 \text{ kN/mm}^2$ .

Sol. Given :

Length,  $L = 30 \text{ m}$ 

Length AB = Length BC = Length CD = 10 m

M.O.I. of AB,  $I = 2 \times 10^{10} \text{ mm}^4 = \frac{2 \times 10^{10}}{10^{12}} \text{ m}^4 = 2 \times 10^{-2} \text{ m}^4$ .M.O.I. of BC,  $3I = 6 \times 10^{-2} \text{ m}^4$ M.O.I. of CD,  $2I = 4 \times 10^{-2} \text{ m}^4$ 

Point load at B = 150 kN

Point load at C = 300 kN

Value of  $E = 2 \times 10^2 \text{ kN/mm}^2 = 2 \times 10^2 \times 10^6 \text{ kN/m}^2 = 2 \times 10^8 \text{ kN/m}^2$ 

Fig. 14.6

To find reactions  $R_A$  and  $R_D$ , take moments about A.

$$\therefore R_D \times 30 = 150 \times 10 + 300 \times 20 = 7500$$

$$\therefore R_D = \frac{7500}{30} = 250 \text{ kN}$$

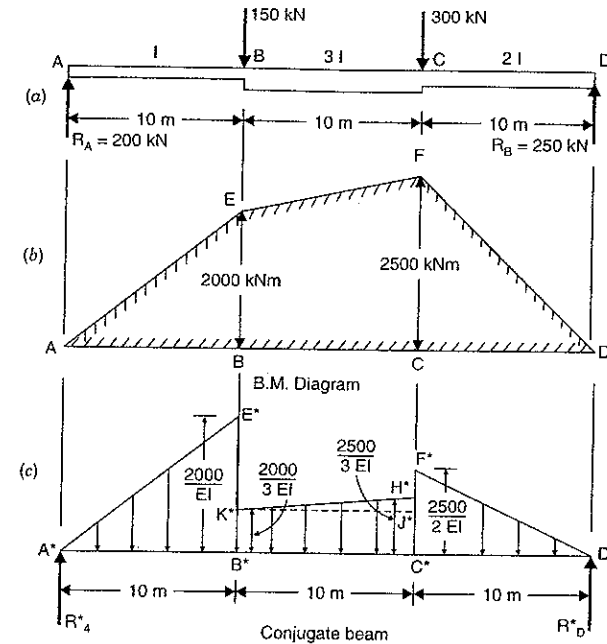
$$\therefore R_A = \text{Total load} - R_D$$

$$= (150 + 300) - 250 = 200 \text{ kN.}$$

Now draw B.M. diagram

B.M. at A and D = 0

B.M. at B =  $R_A \times 10 = 200 \times 10 = 2000 \text{ kNm}$ B.M. at C =  $R_D \times 10 = 250 \times 10 = 2500 \text{ kNm}$ 

B.M. diagram is shown in Fig. 14.6 (b).

Now construct the conjugate beam as shown in Fig. 14.6 (c) by dividing B.M. at any section by their product of  $E$  and  $I$ . For the portion AB corresponding conjugate beam is  $A^*B^*C^*$ , for the portion BC corresponding conjugate beam is  $B^*C^*H^*K^*$  and for the portion CD the corresponding conjugate beam is  $C^*D^*F^*$ . The loading are shown in Fig. 14.6 (c).

$$\text{The ordinates } B^*E^* = \frac{2000}{EI}, \quad B^*K^* = \frac{2000}{3EI}$$

$$C^*F^* = \frac{2500}{2EI}, \quad C^*H^* = \frac{2500}{3EI}$$

$$H^*J^* = \frac{2500}{3EI} - \frac{2000}{3EI} = \frac{500}{3EI}$$

Let  $R_A^*$  = Reaction at  $A^*$  for conjugate beam

$R_D^*$  = Reaction at  $D^*$  for conjugate beam.

To find  $R_A^*$  and  $R_D^*$ , take the moments of all loads acting on the conjugate beam about  $A^*$ , we get

$$\begin{aligned} R_D^* \times 30 &= \left(\frac{1}{2} \times A^*B^* \times B^*E^*\right) \times \left(\frac{2}{3} \times A^*B^*\right) + (B^*C^* \times B^*K^*) \\ &\quad \times \left(10 + \frac{10}{2}\right) + \left(\frac{1}{2} \times K^*J^* \times H^*J^*\right) \times \left(10 + 10 \times \frac{2}{3}\right) \\ &\quad + \left(\frac{1}{2} \times C^*F^* \times C^*D^*\right) \times \left(20 + 10 \times \frac{1}{3}\right) \\ &= \left(\frac{1}{2} \times 10 \times \frac{2000}{EI}\right) \times \left(\frac{2}{3} \times 10\right) + \left(10 \times \frac{2000}{3EI}\right) \times (15) \\ &\quad + \left(\frac{1}{2} \times 10 \times \frac{500}{3EI}\right) \times \left(\frac{50}{3}\right) + \left(\frac{1}{2} \times \frac{2500}{2EI} \times 10\right) \times \left(\frac{70}{3}\right) \\ &= \frac{200000}{3EI} + \frac{300000}{3EI} + \frac{125000}{9EI} + \frac{437500}{3EI} \\ &= \frac{600000 + 900000 + 125000 + 1312500}{9EI} = \frac{2937500}{9EI} \end{aligned}$$

$$R_D^* = \frac{2937500}{9EI \times 30} = \frac{293750}{27EI}$$

$R_A^*$  = Total load on conjugate beam -  $R_D^*$

$$\begin{aligned} &= \left(\frac{1}{2} \times 10 \times \frac{2000}{EI} + 10 \times \frac{2000}{3EI} + \frac{1}{2} \times 10 \times \frac{500}{3EI} + \frac{1}{2} \times 10 \times \frac{2500}{2EI}\right) \\ &\quad - \frac{293750}{27EI} \\ &= \left(\frac{10000}{EI} + \frac{20000}{3EI} + \frac{2500}{3EI} + \frac{6250}{EI}\right) - \frac{293750}{27EI} \\ &= \left(\frac{30000 + 20000 + 2500 + 18750}{3EI}\right) - \frac{293750}{27EI} \\ &= \frac{71250}{3EI} - \frac{293750}{27EI} = \frac{641250 - 293750}{27EI} = \frac{347500}{27EI} \end{aligned}$$

(i) Slopes at A, B, C and D

According to conjugate beam method

(a) Slope at A for the given beam

= S.F. at  $A^*$  for conjugate beam

$$\theta_A = R_A^* = \frac{347500}{27EI} = \frac{347500}{27 \times 2 \times 10^8 \times 2 \times 10^{-2}} = 0.003218 \text{ rad. Ans.}$$

(b) Slope at B for the given beam

= S.F. at  $B^*$  for conjugate beam

=  $R_A^*$  - Load  $A^*B^*E^*$

$$\begin{aligned} &= \frac{347500}{27EI} - \frac{1}{2} \times 10 \times \frac{2000}{EI} \\ &= \frac{347500}{27EI} - \frac{10000}{EI} = \frac{347500 - 270000}{27EI} \end{aligned}$$

$$\begin{aligned} &= \frac{77500}{27EI} = \frac{77500}{27 \times 2 \times 10^8 \times 2 \times 10^{-2}} \\ &= 0.0007176 \text{ radians. Ans.} \end{aligned}$$

(c) Slope at C for the given beam

= S.F. at  $C^*$  for conjugate beam

=  $R_D^*$  - Load  $D^*C^*F^*$

$$\begin{aligned} &= \frac{293750}{27EI} - \frac{1}{2} \times 10 \times \frac{2500}{2EI} \\ &= \frac{293750}{27EI} - \frac{6250}{EI} = \frac{293750 - 27 \times 6250}{27EI} = \frac{125000}{27EI} \\ &= \frac{125000}{27 \times 2 \times 10^8 \times 2 \times 10^{-2}} = 0.001157 \text{ rad. Ans.} \end{aligned}$$

(d) Slope at D for the given beam

= S.F. at  $D^*$  for conjugate beam

$$= R_D^* = \frac{293750}{27EI}$$

$$= \frac{293750}{27 \times 2 \times 10^8 \times 2 \times 10^{-2}} = 0.00272 \text{ rad. Ans.}$$

(ii) Deflection at A, B, C and D

(a) Deflection at A for the given beam

= B.M. at  $A^*$  for the conjugate beam

= 0. Ans.

(b) Deflection at B for the given beam

= B.M. at  $B^*$  for the conjugate beam

=  $R_A^* \times 10$  - Load  $A^*B^*E^* \times$  Distance of C.G. of  $A^*B^*E^*$  from  $B^*$

$$\begin{aligned} &= \frac{347500}{27EI} \times 10 - \left(\frac{1}{2} \times 10 \times \frac{2000}{EI}\right) \times \frac{10}{3} \\ &= \frac{3475000}{27EI} - \frac{100000}{3EI} \\ &= \frac{3475000 - 900000}{27EI} = \frac{2575000}{27EI} \\ &= \frac{2575000}{27 \times 2 \times 10^8 \times 2 \times 10^{-2}} = 0.02384 \text{ m} \\ &= 23.84 \text{ mm. Ans.} \end{aligned}$$

(c) Deflection at C for the given beam

= B.M. at  $C^*$  for the conjugate beam

=  $R_D^* \times 10$  - Load  $D^*C^*F^* \times$  Distance of C.G. of  $D^*C^*F^*$  from  $C^*$

$$\begin{aligned} &= \frac{293750}{27EI} \times 10 - \frac{1}{2} \times 10 \times \frac{2500}{2EI} \times \frac{10}{3} \\ &= \frac{2937500}{27EI} - \frac{62500}{3EI} = \frac{2937500 - 62500 \times 9}{27EI} \end{aligned}$$

$$= \frac{2375000}{27EI} = \frac{2375000}{27 \times 2 \times 10^8 \times 2 \times 10^{-2}} = 0.02199 \text{ m}$$

$$= 21.99 \text{ mm. Ans.}$$

(d) Deflection of  $D$  for the given beam = 0. Ans.

#### 14.5. RELATION BETWEEN ACTUAL BEAM AND CONJUGATE BEAM

The relations between an actual beam and the corresponding conjugate beam for different end conditions are given in Table 14.1.

TABLE 14.1

S. No.	Actual beam	Conjugate beam
1.	Simply supported or roller supported end (Deflection = 0 but slope exists)	Simply supported end B.M. = 0 but S.F. exists
2.	Free end (slope and deflection exist)	Fixed end (S.F. and B.M. exist)
3.	Fixed end (slope and deflection are zero)	Free end (S.F. and B.M. are zero)
4.	Slope at any section	S.F. at the corresponding section
5.	Deflection at any section	B.M. at the corresponding section
6.	Given system of loading	The loading diagram is $M/EI$ diagram
7.	B.M. diagram positive (sagging)	$M/EI$ load diagram is positive (i.e., loading is downward)
8.	B.M. diagram negative (hogging)	$M/EI$ load diagram is negative (i.e., loading is upward)

#### 14.6. DEFLECTION AND SLOPE OF A CANTILEVER WITH A POINT LOAD AT THE FREE END

Fig. 14.7 (a) shows a cantilever  $AB$  of length  $L$  and carrying a point load  $W$  at the free end  $B$ . The B.M. is zero at the free end  $B$  and B.M. at  $A$  is equal to  $W.L$ . The B.M. diagram is shown in Fig. 14.7 (b). The conjugate beam can be drawn by dividing the B.M. at any section by  $EI$ . Fig. 14.7 (c) shows the conjugate beam  $A^*B^*$  (free at  $A^*$  and fixed at  $B^*$ ). The loading on the conjugate beam will be negative (i.e., upwards) as B.M. for cantilever is negative. The loading on conjugate beam is shown in Fig. 14.7 (c).

Let  $\theta_B$  = Slope at  $B$  i.e.,  $\left(\frac{dy}{dx}\right)$  at  $B$  for the given cantilever and

$y_B$  = Deflection at  $B$  for the given cantilever.

Then according to the conjugate beam method,

$$\theta_B = \text{S.F. at } B^* \text{ for the conjugate beam}$$

$$= \text{Load } B^*A^*C^*$$

$$= \frac{1}{2} \times A^*B^* \times A^*C^* = \frac{1}{2} \times L \times \frac{W \cdot L}{EI} = \frac{W \cdot L^2}{2EI}$$

and

$$y_B = \text{B.M. at } B^* \text{ for the conjugate beam}$$

$$= \text{Load } B^*A^*C^* \times \text{Distance of C.G. of } B^*A^*C^* \text{ from } B^*$$

$$= \left(\frac{1}{2} \cdot L \cdot \frac{WL}{EI}\right) \times \left(\frac{2}{3} \times L\right) = \frac{WL^3}{3EI}$$

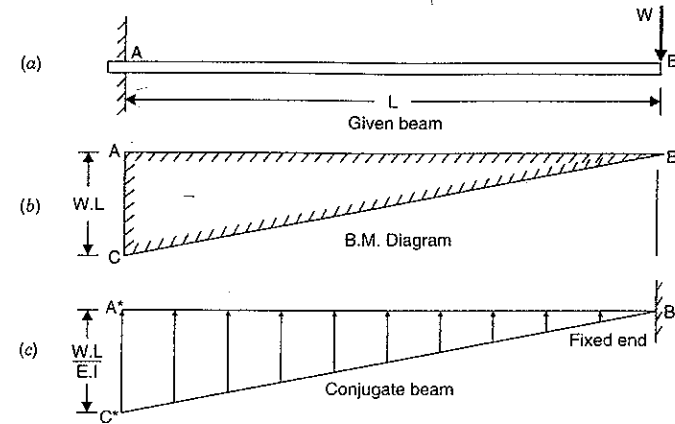

Fig. 14.7

**Problem 14.5.** A cantilever of length 3 m carries a point load of 10 kN at a distance of 2 m from the fixed end. If  $E = 2 \times 10^5 \text{ N/mm}^2$  and  $I = 10^8 \text{ mm}^4$ , find the slope and deflection at the free end using conjugate beam method.

**Sol.** Given :

Length,  $L = 3 \text{ m}$

Point load,  $W = 10 \text{ kN}$

Distance  $AC = 2 \text{ m}$

Value of  $E = 2 \times 10^5 \text{ N/mm}^2$

$$= 2 \times 10^5 \times 10^6 \text{ N/m}^2 = 2 \times 10^8 \text{ kN/m}^2$$

Value of  $I = 10^8 \text{ mm}^4$

$$= 10^8 \times \frac{1}{10^{12}} \text{ m}^4 = 10^{-4} \text{ m}^4$$

B.M. at  $B = 0$

B.M. at  $C = 0$

B.M. at  $A = -10 \times 2 = -20 \text{ kNm}$

Now B.M. can be drawn as shown in Fig. 14.8 (b). Now construct conjugate beam  $A^*B^*$  (free at  $A^*$  and fixed at  $B^*$ ) by dividing the B.M. at any section by  $EI$ , as shown in Fig. 14.8 (c). The loading on the conjugate beam will be negative (i.e., acting upwards) as B.M. is negative.

Let  $\theta_B$  = Slope at the free end for the given cantilever i.e.,  $\left(\frac{dy}{dx}\right)$  at  $B$  and

$y_B$  = Deflection at  $B$  for the given cantilever.

Then according to the conjugate beam method,

$$\theta_B = \text{S.F. at } B^* \text{ for conjugate beam}$$

$$= \text{Load } A^*C^*D^* = \frac{1}{2} \times A^*C^* \times A^*D^*$$



$$= \frac{1}{2} \times 2 \times \frac{20}{EI} = \frac{20}{EI}$$

$$= \frac{20}{2 \times 10^8 \times 10^{-4}} = 0.001 \text{ rad. Ans.}$$

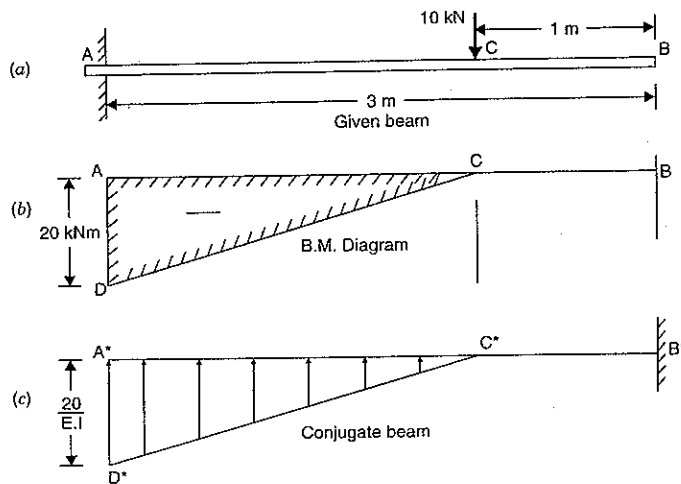

Fig. 14.8

and

$$y_B = \text{B.M. at } B^* \text{ for the conjugate beam}$$

$$= (\text{Load } A^*C^*D^*) \times \text{Distance of C.G. of } A^*C^*D^* \text{ from } B^*$$

$$= \left( \frac{1}{2} \times 2 \times \frac{20}{EI} \right) \times \left( 1 + \frac{2}{3} \times 2 \right)$$

$$= \frac{20}{EI} \times \frac{7}{3} = \frac{20}{2 \times 10^8 \times 10^{-4}} \times \frac{7}{3}$$

$$= 0.00233 \text{ m} = 2.33 \text{ mm. Ans.}$$

**Problem 14.6.** A cantilever beam AB of length 2 m is carrying a point load 10 kN at B. The moment of inertia for the right half of the cantilever is  $10^8 \text{ mm}^4$  whereas that for the left half is  $2 \times 10^8 \text{ mm}^4$ . If  $E = 2 \times 10^8 \text{ kN/m}^2$ , find the slope and deflection at the free end of the cantilever.

**Sol. Given :**

Length,  $L = 2 \text{ m}$

Point load,  $W = 10 \text{ kN}$

Length,  $AC = \text{length } BC = 1 \text{ m}$

M.O.I. of length BC,  $I = 10^8 \text{ mm}^4 = 10^{-4} \text{ m}^4$

M.O.I. of length AC  $= 2 \times 10^8 \text{ mm}^4 = 2 \times 10^{-4} \text{ m}^4 = 2I$

Value of  $E = 2 \times 10^8 \text{ kN/m}^2$

B.M. at B = 0

B.M. at C =  $-10 \times 1 = -10 \text{ kNm}$

B.M. at A =  $-10 \times 2 = -20 \text{ kNm}$ .

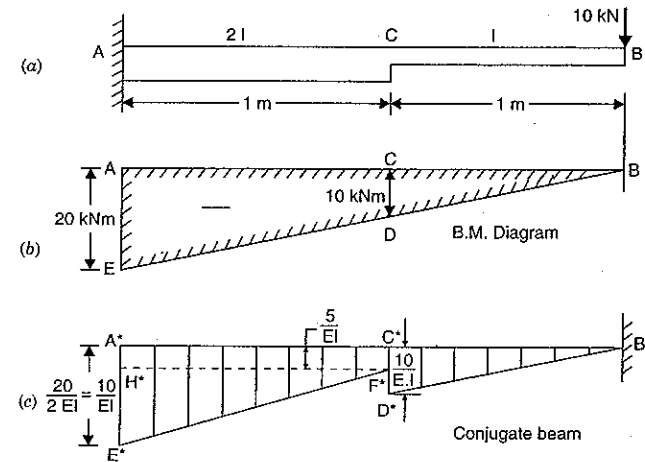

Fig. 14.9

Now B.M. diagram can be drawn as shown in Fig. 14.9 (b). Now construct conjugate beam  $A^*B^*$  (free at  $A^*$  and fixed at  $B^*$ ) by dividing the B.M. at any section by their  $EI$  factor. The loading diagram will be as shown in Fig. 14.9 (c) in which,

$$A^*E^* = \frac{\text{B.M. at A}}{E \times (\text{M.O.I. of AC})} = \frac{20}{E \times 2I} = \frac{10}{EI}$$

$$C^*E^* = \frac{\text{B.M. at C}}{E \times (\text{M.O.I. of AC})} = \frac{10}{E \times 2I} = \frac{5}{EI}$$

$$C^*D^* = \frac{\text{B.M. at C}}{E \times (\text{M.O.I. of BC})} = \frac{10}{E \times I} = \frac{10}{EI}$$

Let  $\theta_B = \text{Slope at B i.e., } \left( \frac{dy}{dx} \right) \text{ at B for the given cantilever}$

$y_B = \text{Deflection at B for the given cantilever.}$

Then according to conjugate beam method,

$$\theta_B = \text{S.F. at } B^* \text{ for conjugate beam}$$

$$= \text{Load } A^*C^*F^*E^* + \text{Load } B^*C^*D^*$$

$$= \frac{1}{2} (A^*E^* + C^*F^*) \times A^*C^* + \frac{1}{2} B^*C^* \times C^*D^*$$

$$= \frac{1}{2} \left( \frac{10}{EI} + \frac{5}{EI} \right) \times 1 + \frac{1}{2} \times 1 \times \frac{10}{EI}$$

$$= \frac{15}{2EI} + \frac{10}{2EI} = \frac{25}{2EI}$$

$$= \frac{25}{2 \times 2 \times 10^8 \times 10^{-4}} = 0.000625 \text{ rad. Ans.}$$

and

$$\begin{aligned}
 y_B &= \text{B.M. at } B^* \text{ for the conjugate beam} \\
 &= \text{Load } A^*C^*F^*H^* \times \text{Distance of its C.G. from } B^* \\
 &\quad + \text{Load } H^*E^*F^* \times \text{Distance of its C.G. from } B^* \\
 &\quad + \text{Load } A^*C^*D^* \times \text{Distance of its C.G. from } B^* \\
 &= \left(1 \times \frac{5}{EI}\right) \times 1.5 + \left(\frac{1}{2} \times 1 \times \frac{5}{EI}\right) \times \left(1 + \frac{2}{3} \times 1\right) + \left(\frac{1}{2} \times 1 \times \frac{10}{EI}\right) \times \left(\frac{2}{3} \times 1\right) \\
 &= \frac{7.5}{EI} + \frac{25}{6EI} + \frac{10}{3EI} = \frac{45 + 25 + 20}{6EI} \\
 &= \frac{90}{6EI} = \frac{15}{EI} = \frac{15}{2 \times 10^8 \times 10^{-4}} \text{ m} \\
 &= 0.00075 \text{ m} = \mathbf{0.75 \text{ mm. Ans.}}
 \end{aligned}$$

**Problem 14.7.** A cantilever of length 3 m carries a uniformly distributed load of 80 kN/m length over the entire length. If  $E = 2 \times 10^8 \text{ kN/m}^2$  and  $I = 10^8 \text{ mm}^4$ , find the slope and deflection at the free end using conjugate beam method.

**Sol. Given :**

$$\begin{aligned}
 \text{Length,} & \quad L = 3 \text{ m} \\
 \text{U.d.l.,} & \quad w = 80 \text{ kN/m} \\
 \text{Value of} & \quad E = 2 \times 10^8 \text{ kN/m}^2
 \end{aligned}$$

$$\text{Value of} \quad I = 10^8 \text{ mm}^4 = \frac{10^8}{10^{12}} \text{ m}^4 = 10^{-4} \text{ m}^4$$

$$\text{B.M. at} \quad B = 0$$

$$\text{B.M. at} \quad A = -(wL) \cdot \frac{L}{2} = -80 \times 3 \times \frac{3}{2} = -360 \text{ kNm}$$

The variation of B.M. between A and B is parabolic as shown in Fig. 14.10 (b).

Now construct conjugate beam  $A^*B^*$  (free at  $A^*$  and fixed at  $B^*$ ) by dividing the B.M. at any section by  $EI$ . The loading diagram will be as shown in Fig. 14.10 (c).

Let  $\theta_B$  = Slope at B for the given cantilever and

$y_B$  = Deflection at B for the given cantilever.

Then according to conjugate beam method,

$$\begin{aligned}
 \theta_B &= \text{S.F. at } B^* \text{ for conjugate beam} \\
 &= \text{Load } B^*A^*C^* \text{ or Area of } B^*A^*C^* \\
 &= \frac{1}{3} \text{ of the rectangle containing parabola} \\
 &= \frac{1}{3} \times (A^*B^* \times A^*C^*) \\
 &= \frac{1}{3} \times 3 \times \frac{360}{EI} \\
 &= \frac{360}{EI} = \frac{360}{2 \times 10^8 \times 10^{-4}} \\
 &= \mathbf{0.008 \text{ rad. Ans.}}
 \end{aligned}$$

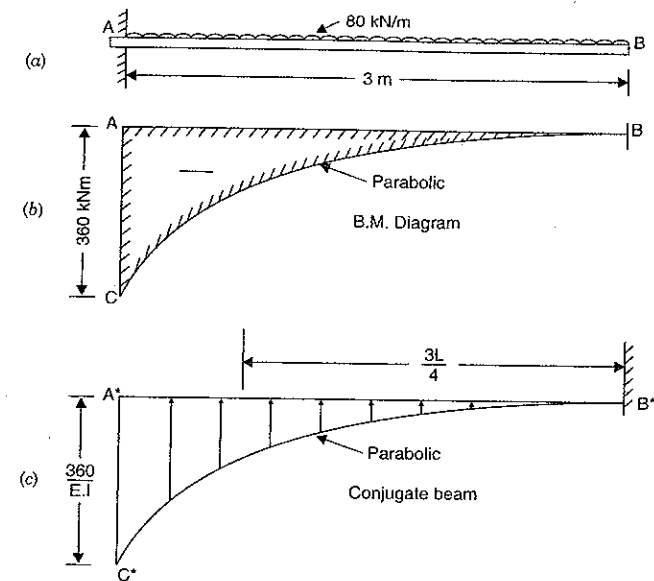

Fig. 14.10

and

$$\begin{aligned}
 y_B &= \text{B.M. at } B^* \text{ for conjugate beam} \\
 &= \text{Load } A^*C^*B^* \times \text{Distance of its C.G. from } B^* \\
 &= \left(\frac{1}{3} \times 3 \times \frac{360}{EI}\right) \times \frac{3L}{4} = \frac{360}{EI} \times \frac{3 \times 3}{4} = \frac{810}{EI} \\
 &= \frac{810}{2 \times 10^8 \times 10^{-4}} = 0.0405 \text{ m} = \mathbf{40.5 \text{ mm. Ans.}}
 \end{aligned}$$

#### 14.7. PROPPED CANTILEVERS AND BEAMS

When a cantilever or a beam carries some load, maximum deflection occurs at the free end in case of cantilever and at the middle point in case of simply supported beam. The deflection can be reduced by providing vertical support at these points or at any suitable point. Propped cantilevers means cantilevers supported on a vertical support at a suitable point. The vertical support is known as prop. The props which does not yield under the loads is known as rigid. The prop (or support) which is of the same height as the original position of the (unloaded) cantilever or beam, does not allow any deflection at the point of support (or prop) when the cantilever or beam is loaded. The prop exerts an upward force on the cantilever or beam. As the deflection at the point of prop is zero, hence the upward force of the prop is such a magnitude as to give an upward deflection at the point of prop equal to the deflection (at the point of prop) due to the load on the beam when there is no prop.

Hence the reaction of the prop (or the upward force of the prop) is calculated by equating the downward deflection due to load at the point of prop to the upward deflection due to prop reaction.

#### 14.8. S.F. AND B.M. DIAGRAMS FOR A PROPPED CANTILEVER CARRYING A POINT LOAD AT THE CENTRE AND PROPPED AT THE FREE END

Fig. 14.11 (a) shows a cantilever  $AB$  of length  $L$  fixed at  $A$  and supported on a prop at  $B$  carrying a point load  $W$  at the centre.

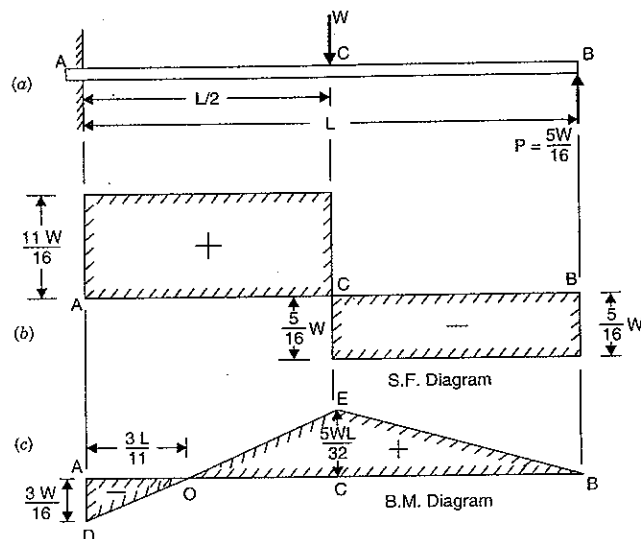

Fig. 14.11

Let  $P$  = Reaction at the rigid prop.

To find the reaction  $P$  at the prop\*, the downward deflection due to  $W$  at the point of prop should be equal to the upward deflection due to prop reaction at  $B$ .

Now we know that downward deflection at point  $B$  due to load  $W$

$$\begin{aligned} &= \frac{W \left(\frac{L}{2}\right)^3}{3EI} + \frac{W \left(\frac{L}{2}\right)^2}{2EI} \times \left(\frac{L}{2}\right) \quad \text{(See equation 13.4)} \\ &= \frac{WL^3}{24EI} + \frac{WL^3}{16EI} \\ &= \frac{2WL^3 + 3WL^3}{48EI} = \frac{5WL^3}{48EI} \quad \dots(i) \end{aligned}$$

The upward deflection at the point  $B$  due to prop reaction  $P$  alone

$$= \frac{PL^3}{3EI} \quad \dots(ii)$$

\*Never calculate  $P$  by equating the clockwise moment due to the load  $W$  to the anticlockwise moment due to  $P$  at the fixed end, as at the fixed end there exist a fixing moment.

Equating equations (i) and (ii), we get

$$\frac{PL^3}{3EI} = \frac{5WL^3}{48EI}$$

$$\therefore P = \frac{5}{16} W \quad \dots(14.1)$$

(i) S.F. Diagrams

$$\begin{aligned} \text{S.F. at } B &= -P \\ &= -\frac{5W}{16} \end{aligned} \quad \text{(Minus sign due to right upwards)}$$

The S.F. will remain constant between  $B$  and  $C$  and equal to  $(-)\frac{5W}{16}$

$$\text{S.F. at } C = -\frac{5W}{16} + W = +\frac{11W}{16}$$

The S.F. will remain  $+\frac{11W}{16}$  between  $C$  and  $A$ .

The S.F. diagram is shown in Fig. 14.11 (b).

(ii) B.M. Diagram

$$\begin{aligned} \text{B.M. at } B &= 0 \\ \text{B.M. at } C &= \frac{5W}{16} \times \frac{L}{2} = \frac{5WL}{32} \\ \text{B.M. at } A &= \frac{5W}{16} \times L - \frac{W \cdot L}{2} \\ &= \frac{5WL - 8WL}{16} = -\frac{3WL}{16} \end{aligned}$$

The B.M. diagram is shown in Fig. 14.11 (c). As the B.M. is changing sign between  $C$  and  $A$ , hence there will be a point of contraflexure between  $C$  and  $A$ . To find its location, equate the B.M. between  $A$  and  $C$  to zero.

The B.M. at any section between  $C$  and  $A$  at a distance  $x$  from  $B$

$$= \frac{5W}{16} \times x - W \left(x - \frac{L}{2}\right)$$

Equating the above B.M. to zero, we get

$$\frac{5W}{16} \cdot x - W \left(x - \frac{L}{2}\right) = 0$$

$$\text{or } \frac{5x}{16} - x + \frac{L}{2} = 0$$

$$\text{or } -\frac{11}{16}x = -\frac{L}{2}$$

$$\text{or } x = \frac{16L}{11 \times 2} = \frac{8L}{11}$$

Hence the point of contraflexure will be at a distance  $8L/11$  from  $B$  or  $3L/11$  from  $A$ .

#### 14.9. S.F. AND B.M. DIAGRAM FOR A PROPPED CANTILEVER CARRYING A UNIFORMLY DISTRIBUTED LOAD AND PROPPED AT THE FREE END

Fig. 14.12 (a) shows a cantilever  $AB$  of length  $L$  fixed at  $A$  and propped at  $B$ , carrying a uniformly distributed load of  $w$ /unit length over its entire length.

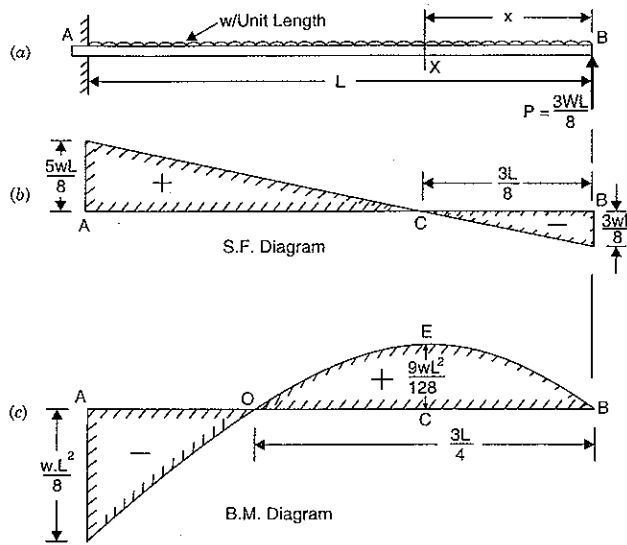

Fig. 14.12

Let  $P$  = Reaction at the prop.

To find the reaction  $P$  at the prop, the downward deflection due to uniformly distributed load at  $B$  should be equated to the upward deflection due to prop reaction at  $B$ .

We know that downward deflection at point  $B$  due to u.d.l.

$$= \frac{wL^4}{8EI} \quad \dots(i) \quad (\text{See equation 13.6})$$

The upward deflection at point  $B$  due to prop reaction  $P$  alone

$$= \frac{PL^3}{3EI} \quad \dots(ii)$$

Equating equations (i) and (ii), we get

$$\frac{PL^3}{3EI} = \frac{w \cdot L^4}{8EI}$$

$$\therefore P = \frac{3}{8} w \cdot L \quad \dots(14.2)$$

(i) S.F. diagram

S.F. at  $B = -P$  (Minus sign due to right upwards)

$$= -\frac{3}{8} wL$$

The S.F. at any section at a distance  $x$  from  $B$  is given by

$$F_x = -\frac{3}{8} w \cdot L + w \cdot x \quad \dots(iii)$$

The S.F. varies by a straight line law between  $A$  and  $B$ . S.F. at  $A$  is obtained by substituting  $x = L$  in the above equation.

$$F_A = -\frac{3}{8} wL + w \cdot L = +\frac{5}{8} w \cdot L$$

To find the point, at which S.F. is zero, equation (iii) should be equated to zero.

$$0 = -\frac{3wL}{8} + wx \quad \text{or} \quad x = \frac{3L}{8}$$

Hence the S.F. is zero at a distance  $3L/8$  from  $B$ . The point of zero shear is shown by  $C$ . The S.F. diagram is shown in Fig. 14.12 (b).

(ii) B.M. diagram

B.M. at  $B = 0$

B.M. at any section at a distance  $x$  from  $B$  is given by,

$$M_x = \frac{3}{8} w \cdot L \cdot x - w \cdot x \cdot \frac{x}{2} \quad \dots(iv)$$

At  $A$ ,  $x = L$  and hence B.M. at  $A$  is given by,

$$M_A = \frac{3}{8} w \cdot L \cdot L - w \cdot L \cdot \frac{L}{2}$$

$$= \frac{3}{8} w \cdot L^2 - \frac{1}{2} w \cdot L^2$$

$$= \frac{(3-4)w \cdot L^2}{8} = -\frac{w \cdot L^2}{8}$$

The S.F. is zero at  $x = \frac{3L}{8}$ , hence B.M. at the point of zero shear is obtained by substituting

$x = \frac{3L}{8}$  in equation (iv). Hence B.M. at  $C$  is given by

$$M_C = \frac{3}{8} w \cdot L \cdot \frac{3L}{8} - w \cdot \frac{3L}{8} \cdot \frac{3L}{8 \times 2}$$

$$= \frac{9wL^2}{64} - \frac{9w \cdot L^2}{128} = \frac{9}{128} w \cdot L^2$$

The B.M. diagram is shown in Fig. 14.12 (c).

(iii) Point of contraflexure

Putting  $M_x = 0$  in equation (iv), we get

$$0 = \frac{3}{8} w \cdot L \cdot x - w \cdot x \cdot \frac{x}{2}$$

or

$$0 = \frac{3}{8} L - \frac{x}{2} \quad (\text{Cancelling } wx)$$

or

$$x = \frac{3 \times 2L}{8} = \frac{3L}{4}$$

(iv) Deflection

The B.M. at any section at a distance  $x$  from  $B$  is given by equation (iv).

$$\therefore M_x = \frac{3}{8} w \cdot L \cdot x - \frac{wx^2}{2}$$

But B.M. at any section is also equal to  $EI \frac{d^2y}{dx^2}$

$$\therefore EI \frac{d^2 y}{dx^2} = \frac{3}{8} w \cdot L \cdot x - \frac{wx^2}{2}$$

Integrating the above equation, we get

$$EI \frac{dy}{dx} = \frac{3w \cdot L \cdot x^2}{8 \times 2} - \frac{w}{2} \cdot \frac{x^3}{3} + C_1$$

$$= \frac{3}{16} w \cdot L \cdot x^2 - \frac{w}{6} \cdot x^3 + C_1 \quad \dots(v)$$

Integrating again, we get

$$EIy = \frac{3}{16} w \cdot L \cdot \frac{x^2}{3} - \frac{w}{6} \cdot \frac{x^4}{4} + C_1 x + C_2$$

$$= \frac{w \cdot L \cdot x^3}{16} - \frac{w}{24} \cdot x^4 + C_1 x + C_2 \quad \dots(vi)$$

where  $C_1$  and  $C_2$  are constant of integration. At the fixed end the slope and deflection are zero. At the end B, deflection is zero. Hence at B,  $x = 0$  and  $y = 0$ .

Substituting  $x = 0$  and  $y = 0$  in equation (vi), we get

$$0 = C_2$$

Substituting  $x = L$  and  $y = 0$  in equation (vi), we get

$$0 = \frac{w \cdot L \cdot L^3}{16} - \frac{w}{24} \cdot L^4 + C_1 \cdot L + 0 \quad (\because C_2 = 0)$$

$$= \frac{wL^3}{16} - \frac{wL^3}{24} + C_1$$

or

$$C_1 = \frac{wL^3}{24} - \frac{wL^3}{16} = \frac{2wL^3 - 3wL^3}{48} = -\frac{wL^3}{48}$$

Substituting the values of  $C_1$  and  $C_2$  in equation (vi), we get

$$EIy = \frac{w \cdot L \cdot x^3}{16} - \frac{w}{24} \cdot x^4 - \frac{wL^3}{48} \cdot x \quad \dots(vii)$$

The above equation gives the deflection at any section of the cantilever.

The deflection at the centre of the cantilever is obtained by substituting  $x = \frac{L}{2}$  in equation (vii). If  $y_c$  is the deflection at the centre then, we have

$$EI \cdot y_c = \frac{wL}{16} \times \left(\frac{L}{2}\right)^3 - \frac{w}{24} \left(\frac{L}{2}\right)^4 - \frac{wL^3}{48} \cdot \frac{L}{2}$$

$$= \frac{wL^4}{16 \times 8} - \frac{wL^4}{24 \times 16} - \frac{wL^4}{96}$$

$$= \frac{3wL^4 - wL^4 - 4wL^4}{24 \times 16} = -\frac{2wL^4}{24 \times 16} = -\frac{wL^4}{192}$$

$$\therefore y_c = -\frac{wL^4}{192EI} \quad (\text{Negative sign means that deflection is downwards})$$

\(\therefore\) Downward deflection,

$$y_c = \frac{wL^4}{192EI} \quad \dots(14.3)$$

(v) Maximum deflection

Maximum deflection takes place where  $\frac{dy}{dx}$  is zero. Differentiating equation (vii) w.r.t.  $x$ , we get

$$EI \frac{dy}{dx} = \frac{3wL}{16} x^2 - \frac{4w}{24} x^3 - \frac{wL^3}{48}$$

$$= \frac{3w \cdot L}{16} x^2 - \frac{w \cdot x^3}{6} - \frac{w \cdot L^3}{48}$$

Putting,  $\frac{dy}{dx} = 0$ , we get

$$0 = \frac{3}{16} w \cdot L \cdot x^2 - \frac{wx^3}{6} - \frac{w \cdot L^3}{48}$$

$$0 = 9w \cdot L \cdot x^2 - 8w \cdot x^3 - wL^3$$

The above equation is solved by trial and error. Hence we get

$$x = 0.422L \quad \dots(14.4)$$

Substituting this value in equation (vii), we get maximum deflection.

$$\therefore EIy_{max} = \frac{wL}{16} \times (.422L)^3 - \frac{w}{24} (.422L)^4 - \frac{wL^3}{48} \times (.422L)$$

$$= -0.005415wL^4$$

$$\therefore y_{max} = \frac{0.005415w \cdot L^4}{EI}$$

\(\therefore\) Maximum downward deflection

$$= \frac{0.005415}{EI} w \cdot L^4 \quad \dots(14.5)$$

**Problem 14.8.** A cantilever of length 6 m carries a point load of 48 kN at its centre. The cantilever is propped rigidly at the free end. Determine the reaction at the rigid prop.

**Sol.** Given :

Length,  $L = 6$  m

Point load,  $W = 48$  kN

Let  $P =$  Reaction at the rigid prop

Using equation (14.1), we get

$$P = \frac{5}{16} \times W$$

$$= \frac{5}{16} \times 48 = 15 \text{ kN. Ans.}$$

**Problem 14.9.** A cantilever of length 4 m carries a uniformly distributed load of 1 kN/m run over the whole length. The cantilever is propped rigidly at the free end. If the value of  $E = 2 \times 10^5$  N/mm<sup>2</sup> and  $I$  of the cantilever =  $10^8$  mm<sup>4</sup>, then determine :

(i) Reaction at the rigid prop,

(ii) The deflection at the centre of the cantilever,

(iii) Magnitude and position of maximum deflection.

**Sol.** Given :

Length,  $L = 4$  m

U.d.l.  $w = 1 \text{ kN/m run}$   
 Value of  $E = 2 \times 10^5 \text{ N/mm}^2 = 2 \times 10^5 \times 10^6 \text{ N/m}^2$   
 $= 2 \times 10^{11} \text{ N/m}^2$   
 Value of  $I = 10^8 \text{ mm}^4 = 10^8 \times 10^{-12} \text{ m}^4 = 10^{-4} \text{ m}^4$

(i) Reaction at the rigid prop

Let  $P =$  Reaction at the rigid prop

Using equation (14.2), we get

$$P = \frac{3}{8} \times w \cdot L$$

$$= \frac{3}{8} \times 1 \times 4 = 1.5 \text{ kN. Ans.}$$

(ii) The deflection at the centre of the cantilever

Let  $y_C =$  Deflection at the centre of cantilever

Using equation (14.3), we get

$$y_C = \frac{wL^4}{192EI}$$

$$= \frac{1000 \times 4^4}{192 \times 2 \times 10^{11} \times 10^{-4}} \text{ m} \quad (\because w = 1 \text{ kN} = 1000 \text{ N})$$

$$= \frac{256}{384 \times 10^4} \text{ m} = \frac{2}{3} \times \frac{1000}{10^4} \text{ mm}$$

$$= 0.0667 \text{ mm. Ans.}$$

(iii) Magnitude and position of maximum deflection

The position of the maximum deflection is given by equation (14.4).

$$\therefore x = 0.422 \times L$$

$$= 0.422 \times 4 = 1.688 \text{ m.}$$

Hence maximum deflection will be at a distance 1.688 m from the free end of the cantilever.

Maximum deflection is given by equation (14.5)

$$\therefore y_{max} = \frac{0.005415w \cdot L^4}{EI}$$

$$= \frac{0.005415 \times 1000 \times 4^4}{2 \times 10^{11} \times 10^{-4}} \text{ m} \quad (\because w = 1 \text{ kN} = 1000 \text{ N})$$

$$= \frac{0.005415 \times 1000 \times 256 \times 1000}{2 \times 10^7} \text{ mm}$$

$$= 0.0693 \text{ mm. Ans.}$$

**Problem 14.10.** A cantilever ABC is fixed at A and rigidly propped at C and is loaded as shown in Fig. 14.13. Find the reaction at C.

**Sol.** Given :

Length,  $L = 6 \text{ m}$   
 U.d.l.,  $w = 1 \text{ kN/m}$   
 Loaded length,  $L_1 = 4 \text{ m}$   
 Let  $P =$  Reaction at the prop C.

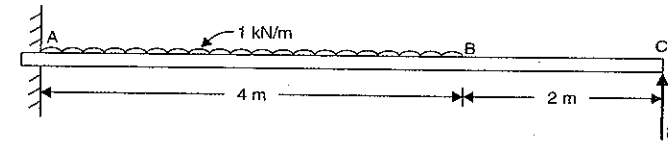

Fig. 14.13

To find the reaction  $P$  at the prop, the downward deflection due to uniformly distributed load on the  $AB$  at point  $C$  should be equated to the upward deflection due to prop reaction at  $C$ .

We know that downward deflection at point  $C$  due to u.d.l. on length  $AB$  is given by,

$$y = \frac{wL_1^4}{8EI} + \frac{wL_1^3}{6EI} (L - L_1)$$

$$= \frac{1 \times 4^4}{8EI} + \frac{1 \times 4^3}{6EI} (6 - 4) = \frac{32}{EI} + \frac{64}{3EI}$$

$$= \frac{96 + 64}{3EI} = \frac{160}{3EI} \quad \dots(i)$$

The upward deflection at point  $C$  due to prop reaction  $P$  alone

$$= \frac{PL^3}{3EI} = \frac{P \times 6^3}{3EI} = \frac{72P}{EI} \quad \dots(ii)$$

Since both the deflections given by equations (i) and (ii) should be equal.

$$\therefore \frac{160}{3EI} = \frac{72P}{EI}$$

or

$$P = \frac{160}{3 \times 72} = 0.741 \text{ kN. Ans.}$$

#### 14.10. S.F. AND B.M. DIAGRAMS FOR A SIMPLY SUPPORTED BEAM WITH A UNIFORMLY DISTRIBUTED LOAD AND PROPPED AT THE CENTRE

Fig. 14.14 (a) shows a simply supported beam  $AB$  of length  $L$  propped at its centre  $C$  and carrying a uniformly distributed load of  $w$ /unit length over its entire span.

Let  $P =$  Reaction of the prop at  $C$

To find the reaction  $P$  at the prop, the downward deflection at  $C$  due to uniformly distributed load should be equated to the upward deflection at  $C$  due to prop reaction.

The downward deflection at the centre of a simply supported beam due to uniformly distributed load is given by,

$$y_C = \frac{5wL^4}{384EI} \quad \dots(i)$$

The upward deflection of the beam at  $C$  due to prop reaction  $P$  alone is given by,

$$y_C = \frac{PL^3}{48EI} \quad \dots(ii)$$

Equating equations (i) and (ii), we get

$$\frac{PL^3}{48EI} = \frac{5wL^4}{384EI}$$

or

$$P = \frac{5wL^4}{384EI} \times \frac{48EI}{L^3}$$

$$= \frac{5}{8} \cdot w \cdot L = \frac{5W}{8} \quad (\because W = w \cdot L)$$

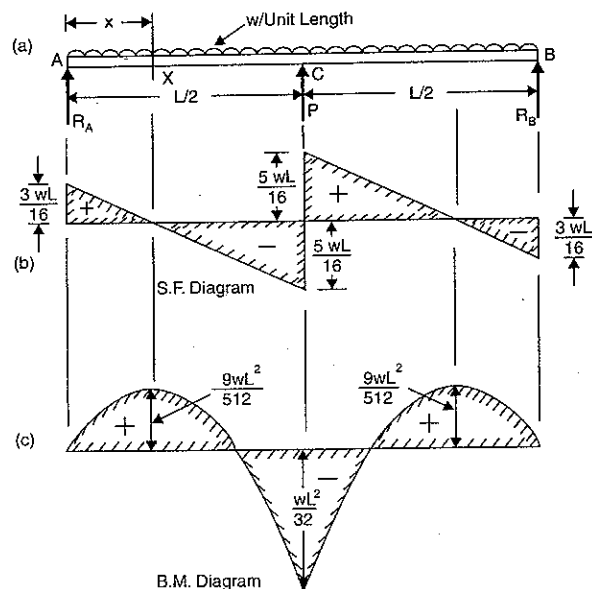

Fig. 14.14

Now reactions  $R_A$  and  $R_B$  can be calculated. Due to symmetry, the reactions  $R_A$  and  $R_B$  would be equal.

$$\text{But } R_A + R_B + P = \text{Total load on beam} = w \cdot L = W$$

$$\therefore R_A + R_A + \frac{5W}{8} = W \quad (\because R_B = R_A \text{ and } P = \frac{5W}{8})$$

or

$$R_A = \frac{1}{2} \left( W - \frac{5W}{8} \right) = \frac{1}{2} \times \frac{3W}{8} = \frac{3W}{16}$$

or

$$R_A = R_B = \frac{3W}{16}$$

(i) S.F. Diagram

$$\text{S.F. at } A = R_A = \frac{3W}{16}$$

The S.F. at any section  $X$  at a distance  $x$  from  $A$  is given by,

$$F_x = \frac{3W}{16} - wx \quad \dots(i)$$

at  $C$ ,

$$x = \frac{L}{2} \text{ and hence S.F. at } C \text{ will be,}$$

$$F_C = \frac{3W}{16} - \frac{wL}{2}$$

$$= \frac{3W}{16} - \frac{W}{2} \quad (\because W = w \cdot L)$$

$$= \frac{3W - 8W}{16} = -\frac{5W}{16}$$

Hence for the span  $AC$ , the S.F. changes uniformly from  $+\frac{3W}{16}$  at  $A$  to  $-\frac{5W}{16}$  at  $C$ .

Similarly for the span  $CB$ , the S.F. will change uniformly from  $+\frac{5W}{16}$  at  $C$  to  $-\frac{3W}{16}$  at  $B$ .

Let at a distance  $x$  from  $A$  in the span  $AC$ , the S.F. is zero. Equating S.F. as zero in equation (i), we get

$$0 = \frac{3W}{16} - w \cdot x$$

$$= \frac{3w \cdot L}{16} - w \cdot x \quad (\because W = w \cdot L)$$

$$= \frac{3L}{16} - x$$

$$x = \frac{3L}{16}$$

Hence S.F. is zero at a distance  $\frac{3L}{16}$  from  $A$ . Also S.F. will be zero at a distance  $\frac{3L}{16}$  from  $B$  due to symmetry. Now the S.F. diagram can be drawn as shown in Fig. 14.14 (b).

(ii) B.M. Diagram

B.M. at  $A$  is zero and also at  $B$  is zero.B.M. at any section  $X$  at a distance  $x$  from  $A$  is given by,

$$M_x = R_A \cdot x - w \cdot x \cdot \frac{x}{2}$$

$$= \frac{3wL}{16} \cdot x - \frac{w \cdot x^2}{2} \quad (\because R_A = \frac{3W}{16} \text{ or } \frac{3w \cdot L}{16}) \quad \dots(ii)$$

The B.M. at  $C$  will be obtained by substituting  $x = \frac{L}{2}$  in the above equation.

$$M_C = \frac{3wL}{16} \cdot \frac{L}{2} - \frac{w \cdot \left(\frac{L}{2}\right)^2}{2}$$

$$= \frac{3w \cdot L^2}{32} - \frac{w \cdot L^2}{8} = \frac{3wL^2 - 4wL^2}{32}$$

$$= -\frac{wL^2}{32} \quad \dots(14.6)$$

Now the B.M. will be maximum where S.F. is zero after changing its sign. But S.F. is zero after changing its sign at a distance  $x = \frac{3L}{16}$  from A.

Hence by substituting  $x = \frac{3L}{16}$  in equation (ii), we get maximum B.M.

$$\begin{aligned} \therefore \text{Max. B.M.} &= \frac{3wL}{16} \cdot \frac{3L}{16} - \frac{w}{2} \cdot \left(\frac{3L}{16}\right)^2 \\ &= \frac{9wL^2}{256} - \frac{9wL^2}{2 \times 256} = \frac{18wL^2 - 9wL^2}{2 \times 256} \\ &= \frac{9wL^2}{512} \end{aligned}$$

To find the position of point of contraflexure, the B.M. must be equated to zero. Hence substituting  $M_x = 0$ , in equation (ii), we get

$$\begin{aligned} 0 &= \frac{3wL}{16} \cdot x - \frac{w}{2} \cdot x^2 \\ &= \frac{3L}{16} - \frac{x}{2} \quad \text{(Cancelling } w \cdot x \text{ to both sides)} \\ \text{or } x &= \frac{3L}{16} \times 2 = \frac{3L}{8} \end{aligned}$$

Now the B.M. diagram can be drawn as shown in Fig. 14.14 (c).

**Problem 14.11.** A uniform girder of length 8 m is subjected to a total load of 20 kN uniformly distributed over the entire length. The girder is freely supported at its ends. Calculate the B.M. and the deflection at the centre.

If a prop is introduced at the centre of the beam so as to nullify this deflection, find the net B.M. at the centre.

**Sol. Given :**

$$\begin{aligned} \text{Length,} & L = 8 \text{ m} \\ \text{Total load,} & W = 20 \text{ kN} \\ \therefore \text{U.d.l.,} & w = \frac{W}{L} = \frac{20}{8} = 2.5 \text{ kN/m.} \end{aligned}$$

(i) The deflection at the centre of a simply supported beam carrying a uniformly distributed load is given by (without prop)

$$y = \frac{5wL^4}{384EI} = \frac{5 \times 2.5 \times 8^4}{384EI} = \frac{400}{3EI} \quad \text{Ans.}$$

where  $EI$  = Stiffness of the girder.

(ii) The B.M. at the centre of a simply supported beam due to uniformly distributed load only (i.e., without prop) is given by

$$M = \frac{wL^2}{8} = \frac{2.5 \times 8^2}{8} = 20 \text{ kNm.} \quad \text{Ans.}$$

(iii) Net B.M. at the centre when a prop is introduced at the centre

Let  $M_C$  = Net B.M. at centre when a prop is provided.

Now using equation (14.6), we get

$$M_C = -\frac{wL^2}{32} = -\frac{2.5 \times 8^2}{32} = -5 \text{ kNm.} \quad \text{Ans.}$$

### 14.11. YIELDING OF A PROP

In case of a rigid prop the downward deflection due to load is equal to the upward deflection due to prop reaction. But if the prop sinks down by some amount say  $\delta$ , then downward deflection due to load is equal to the upward deflection due to prop reaction plus the amount by which the prop sinks down.

If  $y_1$  = Downward deflection of beam at the point of prop due to load,

$y_2$  = Upward deflection of the beam due to prop reaction, and

$\delta$  = Amount by which the prop sinks down

Then  $y = y_2 + \delta$  ...(14.7)

**Problem 14.12.** A cantilever of length  $L$  carries a uniformly distributed load  $w$  per unit length over the whole length. The free end of the cantilever is supported on a prop. If the prop sinks by  $\delta$ , find the prop reaction.

**Sol. Given :**

$$\begin{aligned} \text{Length} &= L \\ \text{U.d.l.} &= w \\ \text{Sinking of prop} &= \delta \end{aligned}$$

The downward deflection ( $y_1$ ) of the free end of cantilever due to uniformly distributed

load is equal to  $\frac{wL^4}{8EI}$ .

The upward deflection ( $y_2$ ) of the free end due to prop reaction  $P$  will be equal to  $\frac{PL^3}{3EI}$ .

Now using equation (14.7), we get

$$y_1 = y_2 + \delta$$

$$\frac{wL^4}{8EI} = \frac{PL^3}{3EI} + \delta$$

$$\text{or } \frac{PL^3}{3EI} = \frac{wL^4}{8EI} - \delta$$

$$\text{or } P = \frac{3EI}{L^3} \left( \frac{wL^4}{8EI} - \delta \right). \quad \text{Ans.}$$

**Problem 14.13.** A simply supported beam of span 10 m carries a uniformly distributed load of 1152 N per unit length. The beam is propped at the middle of the span. Find the amount, by which the prop should yield, in order to make all the three reactions equal.

Take  $E = 2 \times 10^5 \text{ N/mm}^2$  and  $I$  for beam =  $10^8 \text{ mm}^4$ .

**Sol. Given :**

$$\begin{aligned} \text{Span,} & L = 10 \text{ m} \\ \text{U.d.l.,} & w = 1152 \text{ N/m} \\ \text{Value of } E &= 2 \times 10^5 \text{ N/mm}^2 = 2 \times 10^5 \times 10^6 \text{ N/m}^2 \\ &= 2 \times 10^{11} \text{ N/m}^2 \end{aligned}$$

$$\text{Value of } I = 10^8 \text{ mm}^4 = 10^8 \times 10^{-12} \text{ m}^4 = 10^{-4} \text{ m}^4$$

$$\text{Total load on beam, } W = w \cdot L = 1152 \times 10 = 11520 \text{ N}$$

If all the three reactions (i.e.,  $R_A$ ,  $R_B$  and  $P$ ) are equal, then each reaction will be one third of the total load on the beam.



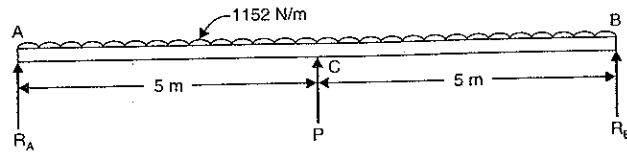

Fig. 14.15

$$\therefore R_A = R_B = P = \frac{W}{3} = \frac{11520}{3} = 3840 \text{ N.}$$

Let  $\delta$  = Amount by which the prop should yield if all the three reactions are equal.

Now the downward deflection of the beam at the centre due to uniformly distributed load alone is given by,

$$y_1 = \frac{5wL^4}{384EI} = \frac{5}{384} \times \frac{1152 \times 10^4}{2 \times 10^{11} \times 10^{-4}} \text{ m}$$

$$= \frac{7.5}{10^3} \text{ m} = \frac{7.5}{10^3} \times 10^3 \text{ mm} = 7.5 \text{ mm.}$$

The upward deflection due to prop reaction at the point of prop is given by,

$$y_2 = \frac{PL^3}{48EI} = \frac{3840 \times 10^3}{48 \times 2 \times 10^{11} \times 10^{-4}} \text{ m} \quad (\because P = 3840 \text{ N})$$

$$= \frac{40}{10^4} \text{ m} = \frac{40 \times 10^3}{10^4} \text{ mm} = 4 \text{ mm}$$

Now using equation (14.7), we get

$$y_1 = y_2 + \delta$$

$$\delta = y_1 - y_2 = 7.5 - 4.0 = 3.5 \text{ mm. Ans.}$$

or

### HIGHLIGHTS

1. The conjugate beam method is used to find the slope and deflections of such beams whose flexural rigidity (*i.e.*,  $EI$ ) is not uniform throughout of its length.
2. Conjugate beam is an imaginary beam of length equal to that of original beam but for which load diagram is  $M/EI$  diagram.
3. The load on conjugate beam at any point is equal to the B.M. at that point divided by  $EI$ .
4. The slope at any section of the given beam = S.F. at the corresponding section of the conjugate beam.
5. The deflection at any point of the given beam = B.M. at the corresponding point of the conjugate beam.
6. Propped cantilevers means cantilevers supported on a vertical supported at a suitable point.
7. The rigid prop does not allow any deflection at the point of prop.
8. The reaction of the prop (or the upward force of the prop) is calculated by equating the downward deflection due to load at the point of prop to the upward deflection due to prop reaction.
9. For a cantilever carrying a uniformly distributed load over the entire span and propped rigidly at the free end, we have

$$(i) \text{ Prop reaction, } P = \frac{3}{8} w.L$$

$$(ii) \text{ B.M. at fixed end, } M = \frac{w.L^2}{8}$$

$$(iii) \text{ Point of contraflexure, } x = \frac{3L}{4}$$

$$(iv) \text{ Deflection at the centre, } y_C = \frac{wL^4}{192EI}$$

$$(v) \text{ Maximum deflection, } y_{max} = \frac{0.005415wL^4}{EI}$$

where  $w$  = Uniformly distributed load,  
 $x$  = Distance from free end.

10. For a simply supported beam, carrying a uniformly distributed load over the entire span and propped at the centre, we have

$$(i) \text{ Prop reaction, } P = \frac{5}{8} W$$

$$(ii) \text{ Support reactions, } R_A = R_B = \frac{3W}{16}$$

$$(iii) \text{ B.M. at centre, } M = -\frac{wL^2}{32}$$

$$(iv) \text{ Point of contraflexure, } x = \frac{3L}{8}$$

where  $W$  = Total load on beam  
 $= w.L$   
 $w$  = Uniformly distributed load on beam  
 $x$  = Distance from the support.

### EXERCISE 14

#### (A) Theoretical Questions

1. Define and explain the terms : Conjugate beam, conjugate beam method, flexural rigidity and propped beam.
2. What is the use of conjugate beam method over other methods ?
3. How will you use conjugate beam method for finding slope and deflection at any section of a given beam ?
4. Find the slope and deflection of a simply supported beam carrying a point load at the centre, using conjugate beam method.
5. A cantilever carries a point load at the free end. Determine the deflection at the free end, using conjugate beam method.
6. What is the relation between an actual beam and the corresponding conjugate beam for different end conditions ?
7. What do you mean by propped cantilevers and beams ? What is the use of propping the beam ?
8. How will you find the reaction at the prop ?
9. A cantilever of length  $L$ , carries a uniformly distributed load of  $w/m$  run over the entire length. It is rigidly propped at the free end. Prove that :

$$(i) \text{ Prop reaction} = \frac{3}{8} w.L \text{ and}$$

$$(ii) \text{ Deflection at the centre} = \frac{WL^4}{192EI}$$

10. A simply supported beam of length  $L$ , carries a uniformly distributed load of  $w/m$  run over the entire span. The beam is rigidly propped at the centre. Determine :
- Prop reactions,
  - Support reactions,
  - B.M. at the centre, and
  - Point of contraflexure, if any.

### (B) Numerical Problems

- A beam 6 m long, simply supported at its ends, is carrying a point load at 50 kN at its centre. The moment of inertia of the beam is  $76 \times 10^6 \text{ mm}^4$ . If  $E = 2.1 \times 10^5 \text{ N/mm}^2$ , determine the slope at the supports and deflection at the centre of the beam using conjugate beam method.  
[Ans. (i) 3.935 and 13.736 mm]
- A simply supported beam of length 10 m, carries a point load of 10 kN at a distance 6 m from the left support. If  $E = 2 \times 10^5 \text{ N/mm}^2$  and  $I = 1 \times 10^8 \text{ mm}^4$ , determine the slope at the left support and deflection under the point load using conjugate beam method.  
[Ans. 6.00028 rad. and 0.96 mm]
- A beam of length 6 m is simply supported at its ends and carries two point loads of 48 kN and 40 kN at a distance of 1 m and 3 m respectively from the left support. Find the deflection under each load. Take  $E = 2 \times 10^5 \text{ N/mm}^2$  and  $I = 85 \times 10^6 \text{ mm}^4$ . Use conjugate beam method.  
[Ans. 9.019 mm and 16.7 mm]
- A beam  $AB$  of span  $L$  is simply supported at  $A$  and  $B$  and carries a point load  $W$  at the centre  $C$  of the span. The moment of inertia of the beam section is  $I$  for the left half and  $2I$  for the right half. Calculate the slope at each end and deflection at the centre.  
[Ans.  $\theta_A = \frac{5WL^2}{96EI}$ ,  $\theta_B = \frac{WL^2}{24EI}$  and  $y_C = \frac{WL^3}{68EI}$ ]
- A cantilever of length 3 m is carrying a point load of 25 kN at the free end. If  $I = 10^8 \text{ mm}^4$  and  $E = 2.1 \times 10^5 \text{ N/mm}^2$ , then determine : (i) slope of the cantilever at the free end and (ii) deflection at the free end using conjugate beam method.  
[Ans. 0.005357 rad. and 10.71 mm]
- A cantilever of length 3 m is carrying a point load of 50 kN at a distance of 2 m from the fixed end. If  $I = 10^8 \text{ mm}^4$  and  $E = 2 \times 10^5 \text{ N/mm}^2$ , find (i) slope at the free end, and (ii) deflection at the free end using conjugate beam method.  
[Ans. 0.005 rad. and 11.67 mm]
- A cantilever of length 5 m carries a point load of 24 kN at its centre. The cantilever is propped rigidly at the free end. Determine the reaction at the rigid prop.  
[Ans. 7.5 kN]
- A cantilever of length 4 m carries a uniformly distributed load of 2 kN/m run over the whole length. The cantilever is propped rigidly at the free end. If  $E = 1 \times 10^5 \text{ N/mm}^2$  and  $I = 10^8 \text{ mm}^4$ , then determine :  
  - reaction at the rigid prop
  - the deflection at the centre of the cantilever, and
  - magnitude and position of maximum deflection.  
[Ans. (i) 3 kN (ii) 0.0667 mm (iii)  $x = 1.688 \text{ m}$ ,  $y_{\max} = 0.0693 \text{ mm}$ ]
- A simply supported beam of length 8 m carries a uniformly distributed load of 1 kN/m run over the entire length. The beam is rigidly propped at the centre. Determine : (i) reaction at the prop (ii) reactions at the supports (iii) net B.M. at the centre and (iv) positions of points of contraflexures.  
[Ans. (i) 5 kN (ii) 1.5 kN (iii) -2.0 kNm (iv) 3 m from each support]
- A cantilever of length 10 m carries a uniformly distributed load of 800 N/m length over the whole length. The free end of the cantilever is supported on a prop. The prop sinks by 5 mm. If  $E = 3 \times 10^5 \text{ N/mm}^2$  and  $I = 10^8 \text{ mm}^4$ , then find the prop reaction.  
[Ans. 2750 N]

# 15

## Fixed and Continuous Beams

### 15.1. INTRODUCTION

A beam whose both ends are fixed is known as a fixed beam. Fixed beam is also called a *built-in* or *encaster beam*. In case of a fixed beam both its ends are rigidly fixed and the slope and deflection at the fixed ends are zero. But the fixed ends are subjected to end moments. Hence end moments are not zero in case of a fixed beam.

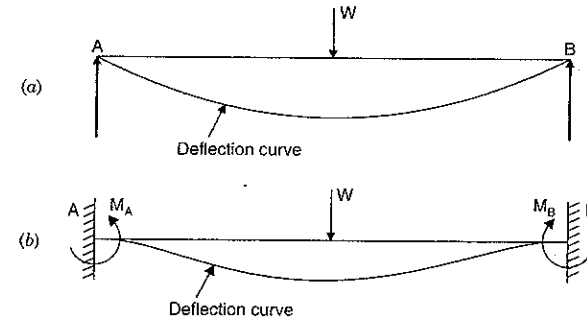

Fig. 15.1

In case of simply supported beam, the deflection is zero at the ends. But the slope is not zero at the ends as shown in Fig. 15.1 (a).

In case of fixed beam, the deflection and slope are zero at the fixed ends as shown in Fig. 15.1 (b). The slope will be zero at the ends if the deflection curve is horizontal at the ends. To bring the slope back to zero (*i.e.*, to make the deflection curve horizontal at the fixed ends), the end moments  $M_A$  and  $M_B$  will be acting in which  $M_A$  will be acting anti-clockwise and  $M_B$  will be acting clockwise as shown in Fig. 15.1 (b).

A beam which is supported on more than two supports is known as continuous beam. This chapter deals with the fixed beams and continuous beam. In case of fixed beams the B.M. diagram, slope and deflection for various types of loading such as point loads, uniformly distributed load and combination of point load and u.d.l., are discussed. In case of continuous beam, Clapeyron's equation of three moments and application of this equation to the continuous beam of simply supported ends and fixed ends are explained.

15.2. BENDING MOMENT DIAGRAM FOR FIXED BEAMS

Fig. 15.1 (c) shows a fixed beam AB of length L subjected to two loads W and 2W at a distance of  $\frac{L}{4}$  from each ends.

Let  $R_A$  = Reaction at A

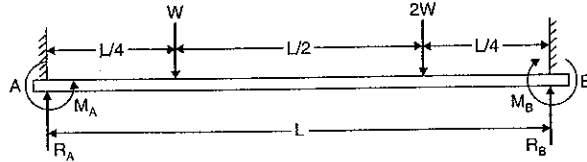

Fig. 15.1 (c)

$R_B$  = Reaction at B  
 $M_A$  = Fixed end moment at A  
 $M_B$  = Fixed end moment at B

The above four quantities i.e.,  $R_A, R_B, M_A$  and  $M_B$  are unknown.

The values of  $R_A, R_B, M_A$  and  $M_B$  are calculated by analysing the given beam in the following two stages :

(i) A simply supported beam subjected to given vertical loads as shown in Fig. 15.2.

Consider the beam AB as simply supported.

Let  $R_A^*$  = Reaction at A due to vertical loads

$R_B^*$  = Reaction at B due to vertical loads.

Taking moments about A, we get

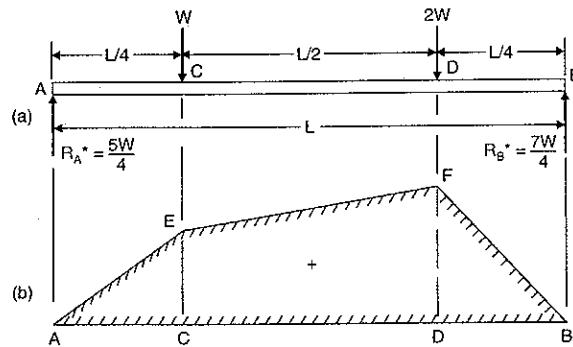

B.M. diagram considering beam as simply supported

Fig. 15.2

$$R_B^* \times L = W \times \frac{L}{4} + 2W \times \frac{3L}{4}$$

$$R_B^* = \frac{W}{4} + \frac{6W}{4} = \frac{7W}{4}$$

$$R_A^* = \text{Total load} - R_B^*$$

and

$$= 3W - \frac{7W}{4} = \frac{5W}{4}$$

B.M. at A = 0, B.M. at B = 0.

$$\text{B.M. at C} = \frac{5W}{4} \times \frac{L}{4} = \frac{5WL}{16}$$

$$\text{B.M. at D} = \frac{7W}{4} \times \frac{L}{4} = \frac{7WL}{16}$$

Now B.M. diagram can be drawn as shown in Fig. 15.2 (b). In this case, B.M. at any point is a sagging (+ve) moment.

(ii) A simply supported beam subjected to end moments only (without given loading) as shown in Fig. 15.3.

Let  $M_A$  = Fixed end moment at A

$M_B$  = Fixed end moment at B

R = Reaction\* at each end due to these moments.

As the vertical loads acting on the beam are not symmetrical (they are W at distance L/4 from A and 2W at a distance L/4 from B), the fixed end moments will be different.

Suppose  $M_B$  is more than  $M_A$  and reaction R at B is acting upwards. Then reaction R at A will be acting downwards as there is no other load on the beam. ( $\Sigma Fy = 0$ ). Taking moments about A, we get clockwise moment at A = Anti-clockwise moment at A.

$$M_B = M_A + R.L$$

$$R = \frac{M_B - M_A}{L}$$

...(A)

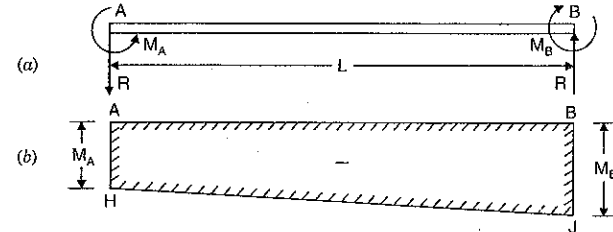

B.M. diagram due to end moments

Fig. 15.3

As  $M_B$  has been assumed more than  $M_A$ , the R.H.S. of equation (A) will be positive. This means the magnitude of reaction R at B is positive. This also means that the direction of reaction R at B is according to our assumption. Hence the reaction R will be upwards at B and downwards at A as shown in Fig. 15.3 (a). The B.M. diagram for this condition is shown in Fig. 15.3 (b). In this case, B.M. at any point is a hogging (-ve) moment.

Since the directions of the two bending moments given by Fig. 15.2 (b) and Fig. 15.3 (b) are opposite to each other, therefore their resultant effect may be obtained by drawing the two moments on the same side of the base AB, as shown in Fig. 15.4.

\*The reaction at each end will be equal. There is no vertical load on the beam hence reaction at A + reaction at B = 0. Or reaction at A = - reaction at B.

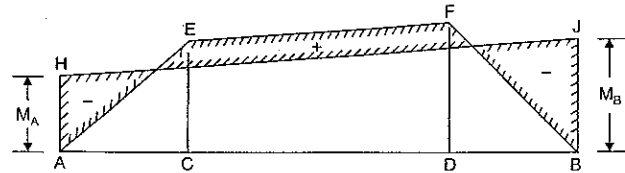

Resultant B.M. diagram

Fig. 15.4

Now the final reactions  $R_A$  and  $R_B$  are given by

$$R_A = R_A^* - R$$

and

$$R_B = R_B^* + R$$

In the above two equations,  $R_A^*$  and  $R_B^*$  are already calculated. They are :  $R_A^* = 5W/4$  and  $R_B^* = 7W/4$ . But the value of  $R$  is in terms of  $M_B$  and  $M_A$ . It is given by  $R = (M_B - M_A)/L$ . Hence to find the value of  $R$ , we must calculate the value of  $M_B$  and  $M_A$  first.

**To find the values of  $M_A$  and  $M_B$**

Let  $M_x$  = B.M. at any section at a distance  $x$  from A due to vertical loads

$M_x'$  = B.M. at any section at a distance  $x$  from A due to end moments.

The resultant B.M. at any section at a distance  $x$  from A

$$= M_x - M_x' \quad (M_x \text{ is +ve but } M_x' \text{ is -ve)}$$

But B.M. at any section is also equal to  $EI \frac{d^2y}{dx^2}$

$$\therefore EI \frac{d^2y}{dx^2} = M_x - M_x' \quad \dots(i)$$

Integrating the above equation for the entire length, we get

$$EI \left[ \frac{dy}{dx} \right]_0^L = \int_0^L M_x dx - \int_0^L M_x' dx$$

But  $\frac{dy}{dx}$  represents the slope. And slope at the fixed ends i.e., at A and B are zero. The above equation can be written as

$$EI \left[ \left( \frac{dy}{dx} \text{ at } x=L \right) - \left( \frac{dy}{dx} \text{ at } x=0 \right) \right]$$

$$= \int_0^L M_x dx - \int_0^L M_x' dx$$

$$EI [0 - 0] = \int_0^L M_x dx - \int_0^L M_x' dx$$

$$\text{or} \quad 0 = \int_0^L M_x dx - \int_0^L M_x' dx \quad \dots(ii)$$

Now  $\int_0^L M_x dx$  represents the area of B.M. diagram due to vertical loads and  $\int_0^L M_x' dx$  represents the area of B.M. diagram due to end moments.

Let  $a$  = Area of B.M. diagram due to vertical loads  
 $a'$  = Area of B.M. diagram due to end moments.

$$\text{Then} \quad \int_0^L M_x dx = a$$

$$\text{and} \quad \int_0^L M_x' dx = a'$$

Substituting these values in equation (ii), we get

$$0 = a - a'$$

or

$$a = a'$$

...(15.1)

The above equation shows that area of B.M. diagram due to vertical loads is equal to the area of B.M. diagram due to end moments.

Again consider the equation (i)

$$EI \frac{d^2y}{dx^2} = M_x - M_x'$$

Multiplying the above equation by  $x$ , we get

$$EI x \frac{d^2y}{dx^2} = x M_x - x M_x'$$

Integrating for the whole length of the beam i.e., from 0 to  $L$ , we get

$$\int_0^L EI x \frac{d^2y}{dx^2} dx = \int_0^L x M_x dx - \int_0^L x M_x' dx$$

$$EI \int_0^L x \frac{d^2y}{dx^2} dx = \int_0^L x M_x dx - \int_0^L x M_x' dx \quad \dots(iii)$$

In the above equation,  $M_x dx$  represents the area of B.M. diagram due to vertical loads at a distance  $x$  from the end A. And the term  $(x M_x dx)$  represents the moment of area of B.M. diagram about the end A. Hence  $\int_0^L x M_x dx$  represents the moment of the total area of B.M. diagram due to vertical loads about A, and it is equal to total area of B.M. diagram due to vertical loads multiplied by the distance of C.G. of area from A,

$$\therefore \int_0^L x M_x dx = a \bar{x}$$

where  $\bar{x}$  = Distance of the C.G. of B.M. diagram due to vertical loads.

$$\text{Similarly} \quad \int_0^L x M_x' dx = a' \bar{x}'$$

where  $\bar{x}'$  = Distance of the C.G. of B.M. diagram due to end moments.

Substituting the above values in equation (iii), we get

$$EI \int_0^L x \frac{d^2y}{dx^2} dx = a \bar{x} - a' \bar{x}'$$

$$\text{or} \quad EI \left[ x \frac{dy}{dx} - y \right]_0^L = a \bar{x} - a' \bar{x}' \quad \left[ \because \frac{d}{dx} \left( x \frac{dy}{dx} - y \right) = \left( x \frac{d^2y}{dx^2} + \frac{dy}{dx} \right) - \frac{dy}{dx} = x \frac{d^2y}{dx^2} \right]$$

or 
$$EI \left[ \left( x \frac{dy}{dx} - y \right)_{\text{at } x=L} - \left( x \frac{dy}{dx} - y \right)_{\text{at } x=0} \right] = a\bar{x} - a' \bar{x}'$$

or 
$$EI [(L\theta_B - y_B) - (0 \times \theta_A - y_A)] = a\bar{x} - a' \bar{x}'$$

Since slope and deflection at A and B are zero, hence  $\theta_A, \theta_B, y_A$  and  $y_B$  are zero.

$$0 = a\bar{x} - a' \bar{x}'$$

or 
$$a\bar{x} = a' \bar{x}' \quad \dots(15.2)$$

But from equation (15.1), we have

$$a = a' \quad \dots(15.3)$$

$$\bar{x} = \bar{x}'$$

Hence the distance of C.G. of B.M. diagram due to vertical loads from A is equal to the distance of C.G. of B.M. diagram due to end moments from A.

Now by using equations (15.1) and (15.3) the unknowns  $M_A$  and  $M_B$  can be calculated.

This also means that  $M_A$  and  $M_B$  can be calculated by

(i) equating the area of B.M. diagram due to vertical loads to the area of B.M. diagram due to end moments.

(ii) equating the distance of C.G. of B.M. diagram due to vertical loads to the distance of C.G. of B.M. diagram due to end moments. The distance of C.G. must be taken from the same end in both cases.

### 15.3. SLOPE AND DEFLECTION FOR A FIXED BEAM CARRYING A POINT LOAD AT THE CENTRE

Fig. 15.5 (a) shows a fixed beam AB of length L, carrying a point load W at the centre C of the beam.

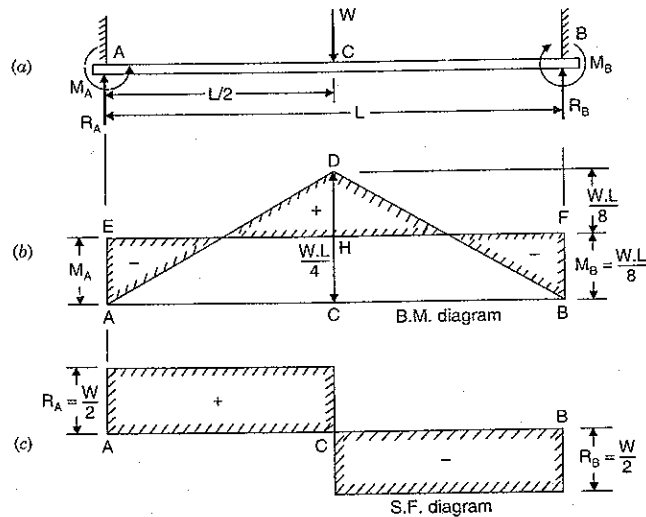

Fig. 15.5

Let  $M_A$  = Fixed end moment at A

$M_B$  = Fixed end moment at B

$R_A$  = Reaction at A

$R_B$  = Reaction at B.

The above four are unknown i.e.,  $R_A, R_B, M_A$  and  $M_B$  are unknown.

(i) B.M. Diagram

Due to symmetry, the end moments  $M_A$  and  $M_B$  will be equal. Hence the B.M. diagram due to end moments will be a rectangle as shown in Fig. 15.5 (b) by AEFB. Here the magnitude of  $M_A$  and  $M_B$  are unknown. The bending moment diagram for a simply supported beam carrying a point load at the centre will be a triangle with the maximum B.M. at the centre equal to  $\frac{W.L}{4}$ . The B.M. diagram for this case is shown in Fig. 15.5 (b) by a triangle ADC in which

$$CD = \frac{W.L}{4}$$

Now according to equation (15.1), area of B.M. diagram due to vertical loads should be equal to the area of B.M. diagram due to end moments.

$\therefore$  Equating the areas of the two bending moment diagrams, we get

Area of triangle ADC = Area of rectangle AEFB

or 
$$\frac{1}{2} \times AB \times CD = AB \times AE$$

or 
$$\frac{1}{2} \times L \times \frac{W.L}{4} = L \times M_A$$

$$M_A = \frac{W.L}{8}$$

Also 
$$M_B = M_A = \frac{W.L}{8} \quad \dots(15.4)$$

Now the B.M. diagram can be drawn as shown in Fig. 15.5 (b).

(ii) S.F. Diagram

Equating the clockwise moments and anti-clockwise moments about A, we get

$$R_B \times L + M_A = M_B + W \cdot \frac{L}{2}$$

But 
$$M_A = M_B$$

$$\therefore R_B \times L = W \cdot \frac{L}{2}$$

or 
$$R_B = \frac{W}{2}$$

Due to symmetry, 
$$R_A = \frac{W}{2}$$

Now the S.F. diagram can be drawn as shown in Fig. 15.5 (c).

There will be two points of contraflexure at a distance of  $\frac{L}{4}$  from the ends.

## (iii) Slope and Deflection

The B.M. at any section between AC at a distance  $x$  from A is given by,

$$\begin{aligned} EI \frac{d^2y}{dx^2} &= R_A \times x - M_A \\ &= \frac{W \cdot x}{2} - \frac{W \cdot L}{8} \end{aligned} \quad \left( \because M_A = \frac{W \cdot L}{8}, R_A = \frac{W}{2} \right)$$

Integrating the above equation, we get

$$EI \frac{dy}{dx} = \frac{W}{2} \cdot \frac{x^2}{2} - \frac{W \cdot L}{8} \cdot x + C_1$$

where  $C_1$  is a constant of integration.

At  $x = 0$ ,  $\frac{dy}{dx} = 0$ . Hence  $C_1 = 0$

Therefore the above equation becomes as

$$EI \frac{dy}{dx} = \frac{Wx^2}{4} - \frac{W \cdot L}{8} x \quad \dots(i)$$

The above equation (i) gives the slope of the beam at any point :

Integrating equation (i) again, we get

$$EIy = \frac{W}{4} \cdot \frac{x^3}{3} - \frac{WL}{8} \cdot \frac{x^2}{2} + C_2$$

where  $C_2$  is another constant of integration. At  $x = 0$ ,  $y = 0$ . Hence  $C_2 = 0$ .

Therefore the above equation becomes as

$$EIy = \frac{W \cdot x^3}{12} - \frac{W \cdot Lx^2}{16} \quad \dots(ii)$$

The above equation (ii) gives the deflection of the beam at any point. The deflection is

maximum at the centre of the beam, where  $x = \frac{L}{2}$ . Hence substituting  $x = \frac{L}{2}$  in equation (ii),

we get

$$\begin{aligned} EIy_{max} &= \frac{W}{12} \left( \frac{L}{2} \right)^3 - \frac{W \cdot L}{16} \cdot \left( \frac{L}{2} \right)^2 \\ &= \frac{WL^3}{96} - \frac{WL^3}{64} = \frac{2WL^3 - 3WL^3}{192} = - \frac{WL^3}{192} \end{aligned}$$

or

$$y_{max} = \frac{-WL^3}{192EI}$$

Minus sign means that the deflection is downwards.

$$\therefore \text{Downward deflection, } y_{max} = \frac{WL^3}{192EI} \quad \dots(15.5)$$

**Note.** The deflection at the centre of a simply supported beam carrying a point load  $W$  at the centre is  $\frac{WL^3}{48EI}$ . Hence the deflection of the simply supported beam is four times the deflection of the fixed beam.

Or in other words, the deflection of a fixed beam is one fourth times the deflection of the simply supported beam. Hence when fixed beams are used, the deflection will be less.

**Problem 15.1.** A fixed beam AB, 6 m long, is carrying a point load of 50 kN at its centre. The moment of inertia of the beam is  $78 \times 10^6 \text{ mm}^4$  and value of  $E$  for beam material is  $2.1 \times 10^5 \text{ N/mm}^2$ . Determine :

(i) Fixed end moments at A and B, and

(ii) Deflection under the load.

**Sol.** Given :

Length,  $L = 6 \text{ m} = 6000 \text{ mm}$

Point load,  $W = 50 \text{ kN} = 50000 \text{ N}$

M.O.I.,  $I = 78 \times 10^6 \text{ mm}^4$

Value of  $E = 2.1 \times 10^5 \text{ N/mm}^2$

Let  $M_A =$  Fixed end moment at A,

$M_B =$  Fixed end moment at B,

$y_{max} =$  Deflection under the central point load.

Using equation (15.4), we get

$$\begin{aligned} M_A = M_B &= \frac{W \cdot L}{8} \\ &= \frac{50 \times 6}{8} = 37.5 \text{ kNm. Ans.} \end{aligned}$$

Using equation (15.5), we get

$$\begin{aligned} y_{max} &= \frac{WL^3}{192EI} \\ &= \frac{50000 \times 6000^3}{192 \times 2.1 \times 10^5 \times 78 \times 10^6} = 3.434 \text{ mm. Ans.} \end{aligned}$$

**Alternate Method**

Fig. 15.5A(b) shows the simply supported beam, which is having Max. B.M. at the centre equal to  $R_A \times 3 = 25 \times 3 = 75 \text{ kNm}$ . Fig. 15.5A (c) shows the B.M. diagram for simply supported beam.

Fig. 15.5A(d) shows the fixed beam with end moments only. Due to symmetry end moments are equal. Hence  $M_A = M_B$ . Fig. 15.5A (e) shows the B.M. diagram due to end moments only. This diagram is a rectangle.

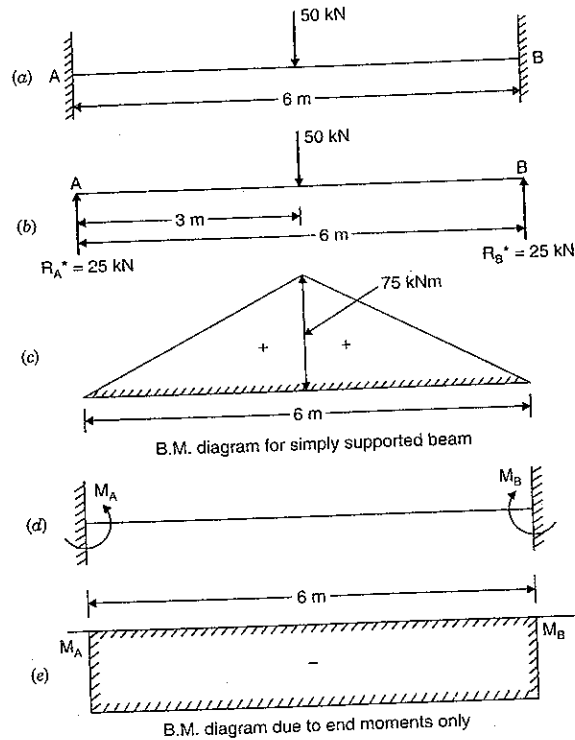

Fig. 15.5A

Equating the areas of two B.M. diagrams, we get  
 Area of B.M. diagram for simply supported beam  
 = Area of B.M. diagram due to end moments.

i.e., 
$$\frac{75 \times 6}{2} = M_A \times 6$$

or 
$$M_A = \frac{75}{2} = 37.5 \text{ kNm}$$

But 
$$M_A = M_B$$
  

$$M_A = M_B = 37.5 \text{ kNm. Ans.}$$

**15.4. SLOPE AND DEFLECTION FOR A FIXED BEAM CARRYING AN ECCENTRIC POINT LOAD**

Fig. 15.6 (a) shows a fixed beam AB of length L, carrying a point load W at C at a distance of 'a' from A and at a distance of 'b' from B. The fixed end moments MA and MB and also reactions at A and B i.e., RA and RB are shown in the same figure.

(i) B.M. Diagram

As the load is not acting symmetrically, therefore MA and MB will be different. In this case MB will be more than MA as the load is nearer to point B. The B.M. diagram due to end moments will be trapezium as shown in Fig. 15.6 (b) by AEFB. Here the length AE (i.e., MA) and BF (i.e., MB) are unknown.

The B.M. diagram for a simply supported beam carrying an eccentric point load will be triangle with maximum B.M. under the point load equal to  $\frac{W \cdot a \cdot b}{L}$ . The B.M. diagram for this case is shown in Fig. 15.6 (b) by a triangle ADB in which  $CD = \frac{W \cdot a \cdot b}{L}$ .

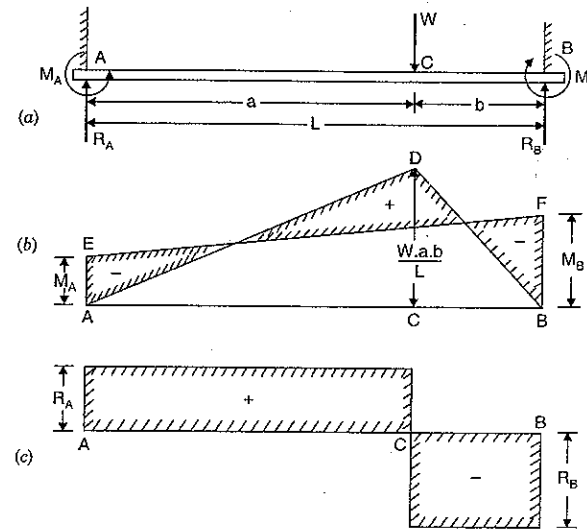

Fig. 15.6

Equating the areas of the two bending moment diagrams, we get  
 Area of trapezium AEFB = Area of triangle ADB

$$\frac{1}{2} (AE + BF) \cdot AB = \frac{1}{2} \times AB \times CD$$

$$\frac{1}{2} (M_A + M_B) \cdot L = \frac{1}{2} \times L \frac{W \cdot a \cdot b}{L}$$

$$M_A + M_B = \frac{W \cdot a \cdot b}{L}$$

...(i)

Now using equation (15.3),

$$\bar{x} = \bar{x}'$$

or Distance of C.G. of B.M. diagram due to vertical loads from A = Distance of C.G. of B.M. diagram due to end moments from A.

Now

$$\bar{x}' = \frac{A_1 x_1 + A_2 x_2}{(A_1 + A_2)} \quad [\text{See Fig. 15.7 (a)}]$$

$$\begin{aligned} &= \frac{(M_A \cdot L) \cdot \frac{L}{2} + \frac{1}{2} \cdot L(M_B - M_A) \times \frac{2L}{3}}{M_A \cdot L + \frac{1}{2} \cdot L(M_B - M_A)} \\ &= \frac{M_A \cdot \frac{L}{2} + (M_B - M_A) \cdot \frac{L}{3}}{M_A + \frac{1}{2}(M_B - M_A)} = \frac{3M_A \cdot L + 2M_B \cdot L - 2M_A \cdot L}{3(2M_A + M_B - M_A)} \\ &= \frac{M_A \cdot L + 2M_B \cdot L}{3(M_A + M_B)} = \frac{(M_A + 2M_B) \cdot L}{3(M_A + M_B)} \end{aligned}$$

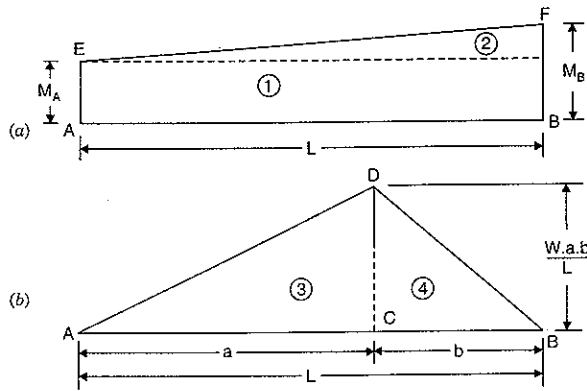

Fig. 15.7

and

$$\bar{x} = \frac{A_3 x_3 + A_4 x_4}{(A_3 + A_4)} \quad [\text{See Fig. 15.7 (b)}]$$

$$= \frac{\left(\frac{1}{2} \times a \times CD\right) \times \frac{2a}{3} + \frac{1}{2} \cdot b \cdot CD \times \left(a + \frac{b}{3}\right)}{\frac{1}{2} \cdot a \cdot CD + \frac{1}{2} \cdot b \cdot CD}$$

$$= \frac{\frac{2a^2}{3} + b\left(a + \frac{b}{3}\right)}{a + b}$$

(Cancelling  $\frac{CD}{2}$ )

$$= \frac{2a^2 + 3ab + b^2}{3(a+b)} = \frac{2a^2 + 2ab + ab + b^2}{3(a+b)}$$

$$= \frac{2a(a+b) + b(a+b)}{3(a+b)} = \frac{(2a+b)(a+b)}{3(a+b)}$$

$$= \frac{2a+b}{3} = \frac{a+(a+b)}{3} = \frac{a+L}{3}$$

( $\because a+b=L$ )

But

$$\bar{x}' = \bar{x}$$

$$\therefore \frac{(M_A + 2M_B) \cdot L}{3(M_A + M_B)} = \frac{a+L}{3}$$

or

$$M_A + 2M_B = \frac{(a+L)(M_A + M_B)}{L}$$

$$\begin{aligned} &= \frac{(a+L)}{L} \cdot \frac{W \cdot a \cdot b}{L} \quad \left[ \because M_A + M_B = \frac{W \cdot a \cdot b}{L} \text{ from equation (i)} \right] \\ &= (a+L) \cdot \frac{W \cdot a \cdot b}{L^2} \quad \dots(ii) \end{aligned}$$

Subtracting equation (i) from equation (ii), we get

$$M_B = (a+L) \cdot \frac{W \cdot a \cdot b}{L^2} - \frac{W \cdot a \cdot b}{L}$$

$$= \frac{W \cdot a \cdot b}{L} \left( \frac{a+L}{L} - 1 \right)$$

$$= \frac{W \cdot a \cdot b}{L} \left( \frac{a+L-L}{L} \right) = \frac{W \cdot a^2 \cdot b}{L^2} \quad \dots(iii)$$

Substituting the value of  $M_B$  in equation (i), we get

$$M_A + \frac{W \cdot a^2 \cdot b}{L^2} = \frac{W \cdot a \cdot b}{L}$$

 $\therefore$ 

$$M_A = \frac{W \cdot a \cdot b}{L} - \frac{W a^2 b}{L^2}$$

$$= \frac{W \cdot a \cdot b}{L^2} (L - a) = \frac{W \cdot a \cdot b \cdot b}{L^2} \quad (\because L - a = b)$$

$$= \frac{W \cdot a \cdot b^2}{L^2} \quad \dots(iv)$$

Now  $M_A$  and  $M_B$  are known and hence bending moment diagram can be drawn. From equations (iii) and (iv), it is clear that if  $a > b$  then  $M_B > M_A$ .

(ii) S. F. Diagram

Equating the clockwise moments and anticlockwise about A,

$$R_B \times L + M_A = M_B + W \cdot a$$

$$\therefore R_B = \frac{(M_B - M_A) + W \cdot a}{L}$$

Similarly

$$R_A = \frac{(M_A - M_B) + W \cdot b}{L}$$

By substituting the values of  $M_A$  and  $M_B$  from equations (iii) and (iv), in the above equations, we shall get  $R_A$  and  $R_B$ . Now S.F. can be drawn as shown in Fig. 15.6 (c).

(iii) Slope and Deflection

The B.M. at any section between AC at a distance  $x$  is given by

$$EI \frac{d^2 y}{dx^2} = R_A \times x - M_A$$



Substituting the value of  $R_A$  in the above equation, we get

$$\begin{aligned} EI \frac{d^2y}{dx^2} &= \left[ \frac{(M_A - M_B) + W \cdot b}{L} \right] \cdot x - M_A \\ &= \frac{(M_A - M_B)}{L} x + \frac{W \cdot b}{L} \cdot x - M_A \\ &= \frac{W \cdot b}{L} \cdot x - \left[ M_A + (M_B - M_A) \frac{x}{L} \right] \end{aligned}$$

Substituting the values of  $M_A$  and  $M_B$ , we get

$$\begin{aligned} EI \frac{d^2y}{dx^2} &= \frac{W \cdot b}{L} \cdot x - \left[ \frac{W \cdot a \cdot b^2}{L^2} + \left( \frac{W \cdot a^2 \cdot b}{L^2} - \frac{W \cdot a \cdot b^2}{L^2} \right) \frac{x}{L} \right] \\ &= \frac{W \cdot b \cdot x}{L} - \frac{W \cdot a \cdot b^2}{L^2} - \left( \frac{W \cdot a^2 \cdot b}{L^2} - \frac{W \cdot a \cdot b^2}{L^2} \right) \frac{x}{L} \\ &= \frac{W \cdot b \cdot x}{L} - \frac{W \cdot a \cdot b^2}{L^2} - \frac{W \cdot a \cdot b}{L^2} (a - b) \cdot \frac{x}{L} \\ &= \frac{W \cdot b \cdot x}{L} - \frac{W \cdot a \cdot b}{L^2} (a - b) \cdot \frac{x}{L} - \frac{W \cdot a \cdot b^2}{L^2} \\ &= \frac{W \cdot b}{L^3} [L^2x - a(a - b)x] - \frac{W \cdot a \cdot b^2}{L^2} \\ &= \frac{W \cdot b}{L^3} (L^2 - a^2 + ab)x - \frac{W \cdot a \cdot b^2}{L^2} \end{aligned}$$

But  $L = a + b$

$$\therefore L^2 = (a + b)^2 = a^2 + b^2 + 2ab.$$

Substituting the value of  $L^2$  in the above equation, we get

$$\begin{aligned} \therefore EI \frac{d^2y}{dx^2} &= \frac{W \cdot b}{L^3} (a^2 + b^2 + 2ab - a^2 + ab)x - \frac{W \cdot a \cdot b^2}{L^2} \\ &= \frac{W \cdot b}{L^3} (b^2 + 3ab)x - \frac{W \cdot a \cdot b^2}{L^2} \\ &= \frac{W \cdot b^2}{L^3} (b + 3a)x - \frac{W \cdot a \cdot b^2}{L^2} \end{aligned}$$

Integrating the above equation, we get

$$EI \frac{dy}{dx} = \frac{W \cdot b^2}{L^3} (b + 3a) \cdot \frac{x^2}{2} - \frac{W \cdot a \cdot b^2}{L^2} x + C_1$$

where  $C_1$  is a constant of integration.

At  $x = 0$ ,  $\frac{dy}{dx} = 0$ . Hence  $C_1 = 0$ .

$$\therefore EI \frac{dy}{dx} = \frac{W \cdot b^2}{2L^3} (b + 3a) \cdot x^2 - \frac{W \cdot a \cdot b^2}{L^2} \cdot x \quad \dots(v)$$

Integrating again, we get

$$EIy = \frac{W \cdot b^2}{2L^3} (b + 3a) \cdot \frac{x^3}{3} - \frac{W \cdot a \cdot b^2}{L^2} \cdot \frac{x^2}{2} + C_2$$

where  $C_2$  is another constant of integration. At  $x = 0$ ,  $y = 0$ . Hence  $C_2 = 0$ .

$$\therefore EIy = \frac{W \cdot b^2}{6L^3} (b + 3a)x^3 - \frac{W \cdot a \cdot b^2}{2L^2} \cdot x^2 \quad \dots(vi)$$

The deflection under the load is obtained by substituting  $x = a$  in the above equation. Let  $y_c$  is the deflection under the load, then

$$\begin{aligned} EIy_c &= \frac{W \cdot b^2}{6L^3} (b + 3a) \cdot a^3 - \frac{W \cdot a \cdot b^2}{2L^2} \cdot a^2 \\ &= \frac{W \cdot b^2 \cdot a^3}{6L^3} \cdot (b + 3a - 3L) \\ &= -\frac{W \cdot a^3 \cdot b^2}{6L^3} (3L - 3a - b) \\ &= -\frac{W \cdot a^3 \cdot b^2}{6L^3} [3(L - a) - b] \\ &= -\frac{W \cdot a^3 \cdot b^2}{6L^3} (3b - b) \quad (\because L - a = b) \\ &= -\frac{W \cdot a^3 \cdot b^3}{3L^3} \\ \therefore y_c &= -\frac{W \cdot a^3 \cdot b^3}{3EIL^3} \quad \dots(15.6) \end{aligned}$$

*Maximum deflection*

Since  $a > b$ , hence maximum deflection will take place between A and C. For maximum deflection,  $\frac{dy}{dx}$  should be zero. Hence substituting  $\frac{dy}{dx} = 0$  in equation (v), we get

$$\begin{aligned} 0 &= \frac{W \cdot b^2}{2L^3} (b + 3a) \cdot x^2 - \frac{W \cdot a \cdot b^2}{L^2} \cdot x \\ \frac{W \cdot a \cdot b^2}{L^2} x &= \frac{W \cdot b^2}{2L^3} (b + 3a)x^2 \\ \therefore x &= \frac{W \cdot a \cdot b^2}{L^2} \times \frac{2L^3}{W \cdot b^2 (b + 3a)} = \frac{2aL}{(b + 3a)} \quad \dots(15.7) \end{aligned}$$

Substituting this value of  $x$  in equation (vi), we get maximum deflection. If  $y_{max}$  represents the maximum deflection, then

$$EIy_{max} = \frac{W \cdot b^2}{6L^3} (b + 3a) \left( \frac{2aL}{b + 3a} \right)^3 - \frac{W \cdot a \cdot b^2}{2L^2} \times \left( \frac{2aL}{b + 3a} \right)^2$$

$$\begin{aligned}
 &= \frac{W \cdot b^2}{6L^3} \cdot \left( \frac{2aL}{b+3a} \right)^2 \left[ (b+3a) \cdot \frac{2aL}{(b+3a)} - 3aL \right] \\
 &= -\frac{Wb^2}{6L^3} \cdot \left( \frac{2aL}{b+3a} \right)^2 \cdot aL \\
 &= -\frac{Wb^2}{6L^3} \cdot \frac{4a^2L^2}{(b+3a)^2} \cdot aL = -\frac{2}{3} \cdot \frac{Wa^3b^2}{(b+3a)^2} \\
 \therefore y_{max} &= -\frac{2}{3EI} \cdot \frac{Wa^3b^2}{(b+3a)^2} \quad \dots(15.8)
 \end{aligned}$$

**Problem 15.2.** A fixed beam AB of length 3 m carries a point load of 45 kN at a distance of 2 m from A. If the flexural rigidity (i.e., EI) of the beam is  $1 \times 10^4$  kNm<sup>2</sup>, determine :

- Fixed end moments at A and B,
- Deflection under the load,
- Maximum deflection, and
- Position of maximum deflection.

**Sol.** Given :

Length,  $L = 3$  m  
 Point load,  $W = 45$  kN  
 Flexural rigidity,  $EI = 1 \times 10^4$  kNm<sup>2</sup>  
 Distance of load from A,

$$a = 2 \text{ m}$$

$\therefore$  Distance of load from B,

$$b = 1 \text{ m}$$

Let  $M_A$  and  $M_B$  = Fixed end moments,

$y_c$  = Deflection under the load

$y_{max}$  = Maximum deflection and

$x$  = Distance of maximum deflection from A.

(i) The fixed end moments at A and B are given by

$$M_A = \frac{W \cdot a \cdot b^2}{L^2} = \frac{45 \times 2 \times 1^2}{3^2} = 10 \text{ kNm. Ans.}$$

and

$$M_B = \frac{W \cdot a^2 \cdot b}{L^2} = \frac{45 \times 2^2 \times 1}{3^2} = 20 \text{ kNm. Ans.}$$

(ii) Deflection under load is given by equation (15.6) as

$$\begin{aligned}
 y_c &= -\frac{W \cdot a^3 \cdot b^3}{3EIL^3} = -\frac{45 \times 2^3 \times 1^3}{3 \times 1 \times 10^4 \times 3^3} = -0.000444 \text{ m} \\
 &= -0.444 \text{ mm. Ans.}
 \end{aligned}$$

-ve sign means the deflection is downwards.

(iii) Maximum deflection is given by equation (15.8) as

$$y_{max} = -\frac{2}{3EI} \times \frac{Wa^3 \cdot b^2}{(b+3a)^2}$$

$$\begin{aligned}
 &= -\frac{2}{3 \times 1 \times 10^4} \cdot \frac{45 \times 2^3 \times 1^2}{(1+3 \times 2)^2} = -\frac{16 \times 45}{3 \times 10^4 \times 49} \\
 &= -0.00049 \text{ m} = -0.49 \text{ m. Ans.}
 \end{aligned}$$

(iv) The distance of maximum deflection from point A is given by equation (15.7) as

$$\begin{aligned}
 x &= \frac{2a \cdot L}{(b+3a)} \\
 &= \frac{2 \times 2 \times 3}{1+3 \times 2} = \frac{12}{7} = 1.714 \text{ m. Ans.}
 \end{aligned}$$

#### Alternate Method

Fig. 15.7A (b) shows the simply supported beam with vertical load of 45 kN at a distance of 2 m from A.

The reactions  $R_A^*$  and  $R_B^*$  due to vertical load will be :

$$3R_B^* = 45 \times 2 \quad \text{or} \quad R_B^* = 90/3 = 30 \text{ kN and } R_A^* = 45 - 30 = 15 \text{ kN.}$$

Fig. 15.7A (c) shows the B.M. diagram with max. B.M. at C and equal to  $R_A^* \times 2 = 15 \times 2 = 30$  kNm.

Fig. 15.7A (d) shows the fixed beam with end moments and reactions. As the vertical load is not acting symmetrically, therefore  $M_A$  and  $M_B$  will be different. In this case  $M_B$  will be more than  $M_A$ , as load is nearer to point B. The B.M. diagram is shown in Fig. 15.7A(e)

(i) Fixed end moments at A and B. To find the value of  $M_A$  and  $M_B$ , equate the areas of two B.M. diagrams.

$\therefore$  Area of B.M. diagram due to vertical loads

= Area of B.M. diagram due to end moments

$$\therefore A_1 + A_2 = A_3 + A_4 \quad \text{where } A_1 = \frac{30 \times 2}{2} = 30, A_2 = \frac{30 \times 1}{2} = 15$$

$$\begin{aligned}
 A_3 &= 3M_A, A_4 = \frac{(M_B - M_A) \times 3}{2} \\
 &= 1.5(M_B - M_A)
 \end{aligned}$$

$$\text{or } 30 + 15 = 3M_A + 1.5M_B - 1.5M_A$$

$$\text{or } 45 = 1.5M_A + 1.5M_B$$

$$\text{or } \frac{45}{1.5} = M_A + M_B \quad \text{or} \quad M_A + M_B = 30 \quad \dots(i)$$

Now equating the distance of C.G. of B.M. diagram due to vertical load to the distance of C.G. of B.M. diagram due to end moments from the same end (i.e., from end A)

$$\text{or } \bar{x} = \bar{x}'$$

$$\text{or } \frac{A_1x_1 + A_2x_2}{A_1 + A_2} = \frac{A_3x_3 + A_4x_4}{A_3 + A_4}$$

$$\text{or } \frac{30 \times \frac{4}{3} + 15 \times \left(2 + \frac{1}{3}\right)}{30 + 15} = \frac{3M_A \times \frac{3}{2} + 1.5(M_B - M_A) \times 2}{3M_A + 1.5M_B - 1.5M_A}$$

$$\text{or } \frac{40 + 35}{45} = \frac{4.5M_A + 3M_B - 3M_A}{1.5M_A + 1.5M_B} = \frac{1.5M_A + 3M_B}{1.5M_A + 1.5M_B}$$

or 
$$\frac{75}{45} = \frac{15(M_A + 2M_B)}{15(M_A + M_B)} \quad \text{or} \quad \frac{5}{3} = \frac{M_A + 2M_B}{M_A + M_B}$$

or 
$$5M_A + 5M_B = 3M_A + 6M_B$$

or 
$$2M_A = M_B \quad \dots(ii)$$

Solving equations (i) and (ii), we get

$$M_A = 10 \text{ kNm and } M_B = 20 \text{ kNm. Ans.}$$

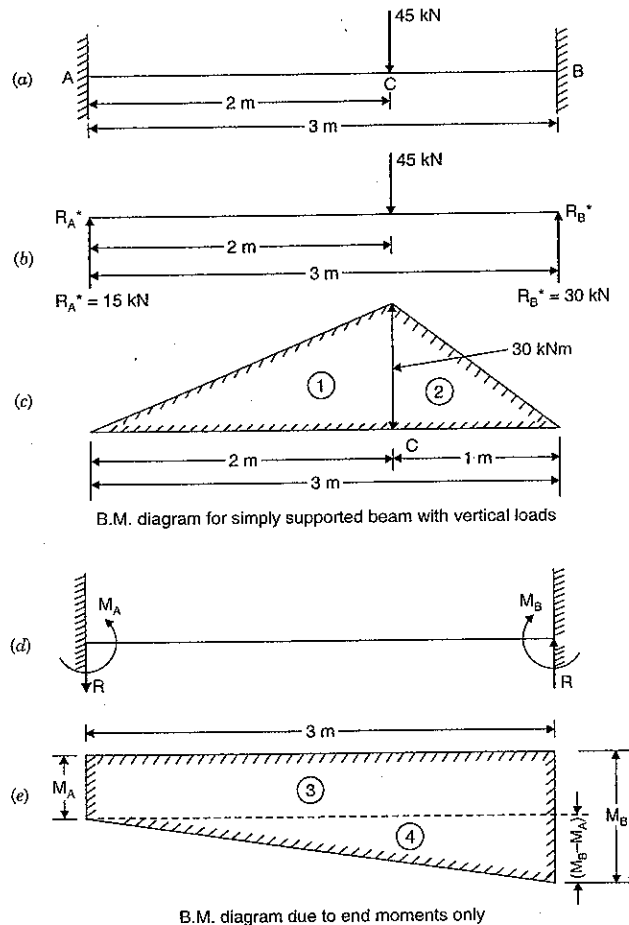

Fig. 15.7A

Let us now find the reaction  $R$  due to end moments only. As the end moments are different, hence there will be reaction at A and B. Both the reactions will be equal and opposite in direction, as there is no vertical load, when we consider end moments only. As  $M_B$  is more, the reaction  $R$  will be upwards at B and downwards at A as shown in Fig. 15.7A (d).

Taking the moments about A for Fig. 15.7A(d), we get clockwise moment at A = Anti-clockwise moments at A

$$M_B = M_A + R \times 3$$

$$\therefore R = \frac{M_B - M_A}{3} = \frac{20 - 10}{3} = \frac{10}{3} \text{ kN}$$

Now the total reaction at A and B will be,

$$R_A = R_A^* - R = 15 - \frac{10}{3} = \frac{35}{3} \text{ kN}$$

and

$$R_B = R_B^* + R = 30 + \frac{10}{3} = \frac{100}{3} \text{ kN}$$

Now, consider the fixed beam as shown in Fig. 15.7B.

The B.M. at any section between AC at a distance  $x$  from A is given by  $R_A \times x - M_A$

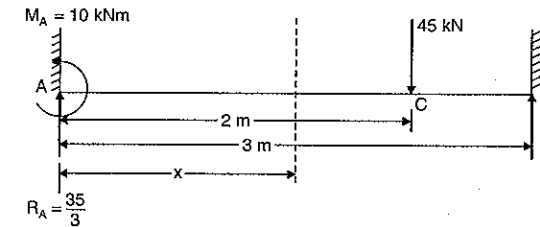

Fig. 15.7B

or

$$EI \frac{d^2 y}{dx^2} = R_A \times x - M_A$$

$$= \frac{35}{3} \times x - 10$$

Integrating, we get

$$EI \frac{dy}{dx} = \frac{35}{3} \times \frac{x^2}{2} - 10x + C_1$$

$$\text{at } x = 0, \frac{dy}{dx} = 0 \quad \therefore C_1 = 0$$

$$\therefore EI \frac{dy}{dx} = \frac{35}{6} x^2 - 10x \quad \dots(iii)$$

Integrating again, we get

$$EI \times y = \frac{35}{6} \times \frac{x^3}{3} - \frac{10x^2}{2} + C_2$$

$$\text{at } x = 0, y = 0, \quad \therefore C_2 = 0$$

$$\therefore EI \times y = \frac{35}{18} x^3 - 5x^2 \quad \dots(iv)$$

(ii) Deflection under the load

From equation (iv), we have

$$y = \frac{1}{EI} \left[ \frac{35}{18} x^3 - 5x^2 \right]$$

To find the deflection under the load, substitute  $x = 2$  m in the above equation.

$$\begin{aligned} \therefore y &= \frac{1}{EI} \left[ \frac{35}{18} \times 2^3 - 5 \times 2^2 \right] \\ &= \frac{1}{1 \times 10^4} \left[ \frac{35 \times 8}{18} - 20 \right] \quad (\because EI = 1 \times 10^4) \\ &= -0.000444 \text{ m} = -0.444 \text{ mm. Ans.} \end{aligned}$$

(-ve sign means the deflection is downwards).

(iii) Maximum deflection

Deflection ( $y$ ) will be maximum when  $\frac{dy}{dx} = 0$ .

Hence substituting the value of  $\frac{dy}{dx} = 0$  in equation (iii), we get

$$0 = \frac{35}{6}x^2 - 10x$$

$$\text{or } 0 = 35x^2 - 60x$$

$$\text{or } 0 = x(35x - 60)$$

This means that either  $x = 0$  or  $35x - 60 = 0$  for maximum deflection.

But  $x$  cannot be zero, because when  $x = 0$ ,  $y = 0$ .

$$\therefore 35x - 60 = 0$$

$$x = \frac{60}{35} = \frac{12}{7} = 1.714 \text{ m}$$

Substituting  $x = 1.714$  m in equation (iv), we get maximum deflection.

$$\therefore EIy_{\max} = \frac{35}{18}(1.714)^3 - 5(1.714)^2$$

$$\text{or } y_{\max} = \frac{1}{EI} \left[ \frac{35}{18}(1.714)^3 - 5(1.714)^2 \right]$$

$$= \frac{1}{1 \times 10^4} [9.79 - 14.69]$$

$$= 0.00049 \text{ m} = 0.49 \text{ mm. Ans.}$$

(iv) Position of maximum deflection

The maximum deflection will be at a distance of 1.714 m (i.e.,  $x = 1.714$  m) from end A.

Ans.

**Problem 15.3.** A fixed beam AB of length 6 m carries point loads of 160 kN and 120 kN at a distance of 2 m and 4 m from the left end A. Find the fixed end moments and the reactions at the supports. Draw B.M. and S.F. diagrams.

**Sol.** Given :

Length = 6 m

Load at C,  $W_C = 160$  kN

Load at D,  $W_D = 120$  kN

Distance AC = 2 m

Distance AD = 4 m

For the sake of convenience, let us first calculate the fixed end moments due to loads at C and D and then add up the moments.

(i) Fixed end moments due to load at C.

For the load at C,  $a = 2$  m and  $b = 4$  m

$$\begin{aligned} \therefore M_{A_1} &= \frac{W_C \cdot a \cdot b^2}{L^2} \\ &= \frac{160 \times 2 \times 4^2}{6^2} = 142.22 \text{ kNm} \end{aligned}$$

$$M_{B_1} = \frac{W_C \cdot a^2 \cdot b}{L^2} = \frac{160 \times 2^2 \times 4}{6^2} = 71.11 \text{ kNm}$$

(ii) Fixed end moments due to load at D.

Similarly for the load at D,  $a = 4$  m and  $b = 2$  m

$$\begin{aligned} \therefore M_{A_2} &= \frac{W_D \cdot a \cdot b^2}{L^2} \\ &= \frac{120 \times 4 \times 2^2}{6^2} = 53.33 \text{ kNm} \end{aligned}$$

and

$$M_{B_2} = \frac{W_D \cdot a^2 \cdot b}{L^2} = \frac{160 \times 4^2 \times 2}{6^2} = 106.66 \text{ kNm}$$

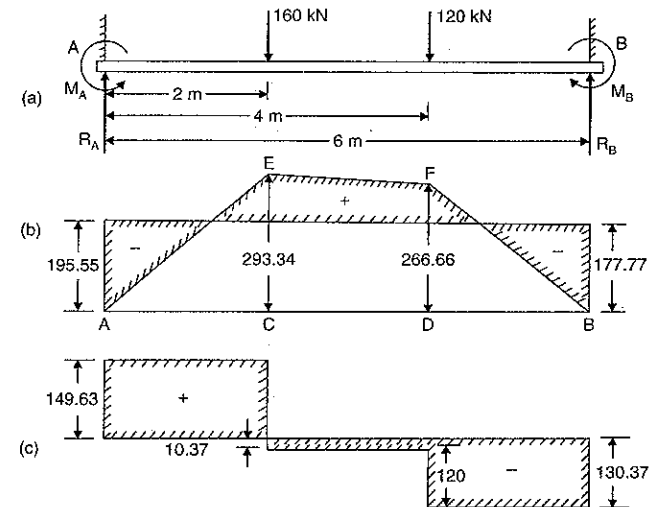

Fig. 15.8

$\therefore$  Total fixing moment at A,

$$\begin{aligned} M_A &= M_{A_1} + M_{A_2} = 142.22 + 53.33 \\ &= 195.55 \text{ kNm. Ans.} \end{aligned}$$

and total fixing moment at  $B$ ,

$$M_B = M_{B_1} + M_{B_2} = 71.11 + 106.66 \\ = 177.77 \text{ kNm. Ans.}$$

*B.M. diagram due to vertical loads*

Consider the beam  $AB$  as simply supported. Let  $R_A^*$  and  $R_B^*$  are the reactions at  $A$  and  $B$  due to simply supported beam. Taking moments about  $A$ , we get

$$R_B^* \times 6 = 160 \times 2 + 120 \times 4 \\ = 320 + 480 = 800$$

$$R_B^* = \frac{800}{6} = 133.33 \text{ kN}$$

and

$$R_A^* = \text{Total load} - R_B^* = (160 + 120) - 133.33 \\ = 146.67 \text{ kN}$$

B.M. at  $A = 0$

B.M. at  $C = R_A^* \times 2 = 146.67 \times 2 = 293.34 \text{ kNm}$

B.M. at  $D = R_B^* \times 2 = 133.33 \times 2 = 266.66 \text{ kNm}$

B.M. at  $B = 0$ .

Now the B.M. diagram due to vertical loads can be drawn as shown in Fig. 15.8 (b).

In the same figure the B.M. diagram due to fixed end moments is also shown.

*S.F. Diagram*

Let  $R_A$  = Resultant reaction at  $A$  due to fixed end moments and vertical loads

$R_B$  = Resultant reaction at  $B$ .

Equating the clockwise moments and anti-clockwise moments about  $A$ , we get

$$R_B \times 6 + M_A = 160 \times 2 + 120 \times 4 + M_B \\ R_B \times 6 + 195.55 = 320 + 480 + 177.77$$

or

$$R_B = \frac{800 + 177.77 - 195.55}{6} = 130.37 \text{ kN}$$

and

$$R_A = \text{Total load} - R_B \\ = (160 + 120) - 130.37 = 149.63 \text{ kN}$$

S.F. at  $A = R_A = 149.63 \text{ kN}$

S.F. at  $C = 149.63 - 160 = -10.37 \text{ kN}$

S.F. at  $D = -10.37 - 120 = -130.37 \text{ kN}$

S.F. at  $B = -130.37 \text{ kN}$

Now S.F. diagram can be drawn as shown in Fig. 15.8 (c).

**Alternate Method**

Fig. 15.8A (b) shows the simply supported beam with vertical loads.

Let  $R_A^*$  and  $R_B^*$  are the reactions at  $A$  and  $B$  due to vertical loads. Taking moments about  $A$ , we get

$$R_B^* \times 6 = 160 \times 2 + 120 \times 4 = 320 + 480 = 800$$

$$R_B^* = \frac{800}{6} = \frac{400}{3} = 133.33 \text{ kN}$$

and

$$R_A^* = \text{Total load} - R_B^* \\ = (160 + 120) - 133.33 = 146.67 \text{ kN}$$

B.M. at  $A = 0$

B.M. at  $C = R_A^* \times 2 = 146.67 \times 2 = 293.34 \text{ kNm}$

B.M. at  $D = R_B^* \times 2 = 133.33 \times 2 = 266.66 \text{ kNm}$

Now the B.M. diagram due to vertical loads can be drawn as shown in Fig. 15.8A(c)

Fig. 15.8A (d) shows the fixed beam with end moments only. As the load  $160 \text{ kN}$  is nearer to end  $A$ , hence  $M_A$  will be more than  $M_B$ . The B.M. diagram due to end moments is shown in Fig. 15.8A(e).

To find the values of  $M_A$  and  $M_B$ , equate the areas of two B.M. diagrams.

$\therefore$  Area of B.M. diagram due to vertical loads

= Area of B.M. diagram due to end moments

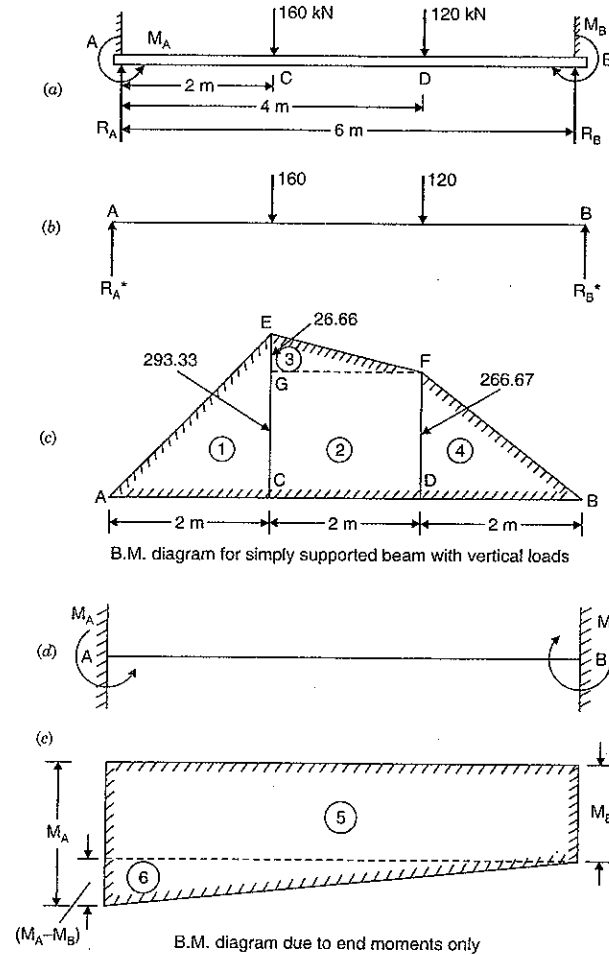

Fig. 15.8A

$$\therefore A_1 + A_2 + A_3 + A_4 = A_5 + A_6 \quad \dots(i)$$

$$\text{where } A_1 = \frac{AC \times CE}{2} = \frac{2 \times 293.33}{2} = 293.33$$

$$A_2 = CD \times DF = 2 \times 266.67 = 533.34$$

$$A_3 = \frac{GF \times GE}{2} = \frac{2 \times 26.66}{2} = 66.66$$

$$A_4 = \frac{DB \times DF}{2} = \frac{2 \times 266.67}{2} = 266.67$$

$$A_5 = M_B \times 6 = 6M_B, A_6 = \frac{6 \times (M_A - M_B)}{2} = 3(M_A - M_B) = 3M_A - 3M_B$$

Substituting these values in equation (i), we get

$$293.33 + 533.34 + 66.66 + 266.67 = 6M_B + 3M_A - 3M_B$$

$$\text{or } 1119.98 = 3M_B + 3M_A = 3(M_B + M_A)$$

$$\therefore M_B + M_A = \frac{1119.98}{3} = 373.33 \quad \dots(ii)$$

To get the other equation between  $M_A$  and  $M_B$ , equate the distance of C.G. of B.M. diagram due to vertical loads to the distance of C.G. of B.M. diagram due to end moments from end A.

$$\begin{aligned} \bar{x} &= \bar{x}' \\ \frac{A_1x_1 + A_2x_2 + A_3x_3 + A_4x_4}{A_1 + A_2 + A_3 + A_4} &= \frac{A_5x_5 + A_6x_6}{A_5 + A_6} \\ 293.33 \times \frac{4}{3} + 533.34 \times 3 + 26.66 \times \left(2 + \frac{2}{3}\right) + 266.66 \times \left(4 + \frac{2}{3}\right) & \\ &= \frac{6M_B \times 3 + 3(M_A - 3M_B) \times \frac{1}{3} \times 6}{6M_B + 3M_A - 3M_B} \end{aligned}$$

$$\begin{aligned} \frac{391.1 + 1600 + 70.91 + 1245.35}{1119.98} &= \frac{3(6M_B + 2M_A - 2M_B)}{3(M_B + M_A)} \\ 2.95 &= \frac{4M_B + 2M_A}{M_B + M_A} \end{aligned}$$

$$2.95M_B + 2.95M_A = 4M_B + 2M_A$$

$$2.95M_A - 2M_A = 4M_B - 2.95M_B$$

$$0.95M_A = 1.05M_B$$

$$M_A = \frac{1.05}{0.95} M_B = 1.1M_B \quad \dots(iii)$$

Substituting this value of  $M_A$  in equation (ii), we get

$$M_B + 1.1M_B = 373.33$$

$$\text{or } M_B = \frac{373.33}{2.1} = 177.77 \text{ kNm. Ans.}$$

From equation (iii),  $M_A = 1.1 \times 177.77 = 195.55 \text{ kNm. Ans.}$

### Combined B.M. Diagram

$M_A = 195.55 \text{ kNm}$  and  $M_B = 177.77 \text{ kNm}$ . Now the combined B.M. diagram can be drawn as shown in Fig. 15.8 (b).

To draw the S.F. diagram, let us first find the values of resultant reactions due to vertical loads and fixed end moments  $R_A$  and  $R_B$ . Refer to Fig. 15.8A(a). Taking moments about A, we get clockwise moments at A = Anti-clockwise moments at A

$$\therefore 160 \times 2 + 120 \times 4 + M_B = M_A + R_B \times 6$$

$$\text{or } 320 + 480 + M_B = M_A + 6R_B$$

$$\text{or } 800 + 177.77 = 195.55 + 6R_B$$

$$\therefore R_B = \frac{800 + 177.77 - 195.55}{6} = 130.37 \text{ kN}$$

$$\text{and } R_A = \text{Total load} - R_B = (160 + 120) - 130.37 = 149.63 \text{ kN}$$

### S.F. Diagram

$$\text{S.F. at A} = R_A = 149.63 \text{ kN}$$

$$\text{S.F. at C} = 149.63 - 160 = -10.37 \text{ kN}$$

$$\text{S.F. at D} = -10.37 - 120 = -130.37 \text{ kN}$$

$$\text{S.F. at B} = -130.37 \text{ kN}$$

Now S.F. diagram can be drawn as shown in Fig. 15.8(c).

**Problem 15.4.** A fixed beam of length 6 m carries two point loads of 30 kN each at a distance of 2 m from both ends. Determine the fixed end moments and draw the B.M. diagram.

**Sol.** Given :

$$\text{Length, } L = 6 \text{ m}$$

$$\text{Point load at C, } W_1 = 30 \text{ kN}$$

$$\text{Point load at D, } W_2 = 30 \text{ kN}$$

$$\text{Distance } AC = 2 \text{ m}$$

$$\text{Distance } AD = 4 \text{ m}$$

The fixing moment at A due to loads at C and D is given by

$$M_A = \text{Fixing moment due to load at C} + \text{Fixing moment due to load at D}$$

$$= \frac{W_1 a_1 b_1^2}{L^2} + \frac{W_2 a_2 b_2^2}{L^2}$$

$$= \frac{30 \times 2 \times 4^2}{6^2} + \frac{30 \times 4 \times 2^2}{6^2} = \frac{80}{3} + \frac{40}{3} = 40 \text{ kNm.}$$

Since the beam and loading is symmetrical, therefore fixing moments at A and B should be equal.

$$\therefore M_B = M_A = 40 \text{ kNm. Ans.}$$

To draw the B.M. diagram due to vertical loads, consider the beam AB as simply supported. The reactions at the simply supported beam will be equal to 30 kN each.

$$\text{B.M. at A and B} = 0$$

$$\text{B.M. at C} = 30 \times 2 = 60 \text{ kNm}$$

$$\text{B.M. at D} = 30 \times 2 = 60 \text{ kNm.}$$

Now the B.M. diagram due to vertical loads and due to end moments can be drawn as shown in Fig. 15.9 (b).

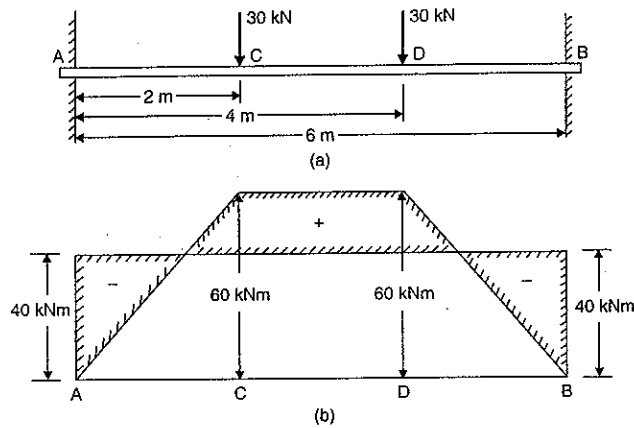

Fig. 15.9

### 15.5. SLOPE AND DEFLECTION FOR A FIXED BEAM CARRYING A UNIFORMLY DISTRIBUTED LOAD OVER THE ENTIRE LENGTH

Fig. 15.10 (a) shows a fixed beam of length  $L$ , carrying uniformly distributed load of  $w$ /unit length over the entire length.

Let  $M_A$  = Fixed end moment at A  
 $M_B$  = Fixed end moment at B  
 $R_A$  = Reaction at A  
 $R_B$  = Reaction at B.

(i) *B.M. Diagram*

Since the loading on the beam is symmetrical, hence  $M_A = M_B$ . The B.M. diagram due to end moments will be a rectangle as shown in Fig. 15.10 (b) by  $AEFB$ . The magnitude of  $M_A$  or  $M_B$  is unknown.

The B.M. diagram for a simply supported beam carrying a uniformly distributed load will be parabola whose central ordinate will be  $wL^2/8$ . The B.M. diagram for this case is shown

in Fig. 15.10 (b) by parabola  $ADB$  in which  $CD = \frac{wL^2}{8}$ .

Equating the areas of the two bending moment diagrams, we get

Area of rectangle  $AEFB$  = Area of parabola  $ADB$

$$AB \times AE = \frac{2}{3} \times [AB \times CD]$$

$$L \times M_A = \frac{2}{3} \times L \times \frac{wL^2}{8} \quad \text{or} \quad M_A = \frac{wL^2}{12}$$

$$\therefore M_B = M_A = \frac{wL^2}{12} \quad \dots(15.9)$$

Now the B.M. diagram can be drawn as shown in Fig. 15.10 (b).

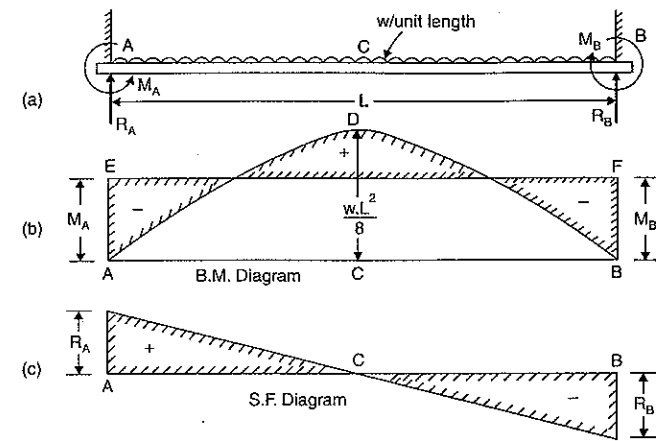

Fig. 15.10

(ii) *S.F. Diagram*

Equating the clockwise moments and anti-clockwise moments about A, we get

$$R_B \times L + M_A = wL \cdot \frac{L}{2} + M_B$$

But  $M_A = M_B$

$$\therefore R_B \times L = wL \cdot \frac{L}{2} \quad \text{or} \quad R_B = \frac{wL}{2}$$

Due to symmetry,

$$R_A = R_B = \frac{wL}{2} \quad \dots(15.10)$$

Now the S.F. diagram can be drawn as shown in Fig. 15.10 (c).

(iii) *Slope and deflection*

The B.M. at any section at a distance  $x$  from A is given by,

$$\begin{aligned} EI \frac{d^2y}{dx^2} &= R_A \times x - M_A - wx \cdot \frac{x}{2} \\ &= \frac{wL}{2} \cdot x - \frac{wL^2}{12} - \frac{wx^2}{2} \quad \left( \because R_A = \frac{wL}{2}, M_A = \frac{wL^2}{12} \right) \\ &= \frac{wLx}{2} - \frac{wx^2}{2} - \frac{wL^2}{12} \quad \dots(i) \end{aligned}$$

Integrating the above equation, we get

$$\begin{aligned} EI \frac{dy}{dx} &= \frac{wL}{2} \cdot \frac{x^2}{2} - \frac{wx^3}{2 \cdot 3} - \frac{wL^2}{12} \cdot x + C_1 \\ &= \frac{wL}{4} \cdot x^2 - \frac{w}{6} x^3 - \frac{wL^2}{12} \cdot x + C_1 \end{aligned}$$

where  $C_1$  is a constant of integration.

and 
$$EIy = \frac{w \cdot L}{12} x^3 - \frac{w}{24} \cdot x^4 + \left( -\frac{wL^3}{24} \right) x + 0 \quad (\because C_2 = 0)$$

or 
$$EIy = \frac{w \cdot L}{12} x^3 - \frac{w}{24} \cdot x^4 - \frac{wL^3}{24} x \quad \dots(iv)$$

The equation (iii) is known as *slope equation*. We can find the slope (i.e., the value of  $\frac{dy}{dx}$ )

at any point on the beam by substituting the different values of  $x$  in this equation.

The equation (iv) is known as *deflection equation*. We can find the deflection (i.e., the value of  $y$ ) at any point on the beam by substituting the different values of  $x$  in this equation.

*Slope at the supports*

Let  $\theta_A =$  Slope at support A. This is equal to  $\left( \frac{dy}{dx} \right)_{at A}$

and  $\theta_B =$  Slope at support B =  $\left( \frac{dy}{dx} \right)_{at B}$

At A,  $x = 0$  and  $\frac{dy}{dx} = \theta_A$ .

Substituting these values in equation (iii), we get

$$\begin{aligned} EI\theta_A &= \frac{wL}{4} \times 0 - \frac{w}{6} \times 0 - \frac{wL^3}{24} \\ &= \frac{wL^3}{24} = -\frac{WL^2}{24} \quad (\because w \cdot L = W = \text{Total load}) \end{aligned}$$

$$\therefore \theta_A = -\frac{WL^2}{24EI} \quad \dots(12.12)$$

(Negative sign means that tangent at A makes an angle with AB in the anti-clockwise direction)

By symmetry,  $\theta_B = -\frac{WL^2}{24EI} \quad \dots(12.13)$

*Maximum Deflection*

The maximum deflection is at the centre of the beam i.e., at point C, where  $x = \frac{L}{2}$ . Let  $y_C$

= deflection at C which is also maximum deflection. Substituting  $y = y_C$  and  $x = \frac{L}{2}$  in the

equation (iv), we get

$$\begin{aligned} EIy_C &= \frac{w \cdot L}{12} \cdot \left( \frac{L}{2} \right)^3 - \frac{w}{24} \cdot \left( \frac{L}{2} \right)^4 - \frac{wL^3}{24} \cdot \left( \frac{L}{2} \right) \\ &= \frac{w \cdot L^4}{96} - \frac{wL^4}{384} - \frac{wL^4}{48} = -\frac{5wL^4}{384} \end{aligned}$$

$$\therefore y_C = -\frac{5}{384} \cdot \frac{wL^4}{EI} = -\frac{5}{384} \cdot \frac{W \cdot L^3}{EI} \quad (\because w \cdot L = W = \text{Total load})$$

Negative sign indicates that deflection is downwards.

$\therefore$  Downward deflection,

$$y_C = \frac{5}{384} \cdot \frac{WL^3}{EI} \quad \dots(12.14)$$

**Problem 12.5.** A beam of uniform rectangular section 200 mm wide and 300 mm deep is simply supported at its ends. It carries a uniformly distributed load of 9 kN/m run over the entire span of 5 m. If the value of  $E$  for the beam material is  $1 \times 10^4$  N/mm<sup>2</sup>, find :

- (i) the slope at the supports and (ii) maximum deflection.

**Sol.** Given :

Width,  $b = 200$  mm

Depth,  $d = 300$  mm

M.O.I.,  $I = \frac{bd^3}{12} = \frac{200 \times 300^3}{12} = 4.5 \times 10^8$  mm<sup>4</sup>

U.d.l.,  $w = 9$  kN/m = 9000 N/m

Span,  $L = 5$  m = 5000 mm

$\therefore$  Total load,  $W = w \cdot L = 9000 \times 5 = 45000$  N

Value of  $E = 1 \times 10^4$  N/mm<sup>2</sup>

Let  $\theta_A =$  Slope at the support

and  $y_C =$  Maximum deflection.

(i) Using equation (12.12), we get

$$\begin{aligned} \theta_A &= -\frac{W \cdot L^2}{24EI} \\ &= -\frac{45000 \times 5000^2}{24 \times 1 \times 10^4 \times 4.5 \times 10^8} \text{ radians} \\ &= \mathbf{0.0104 \text{ radians. Ans.}} \end{aligned}$$

(ii) Using equation (12.14), we get

$$\begin{aligned} y_C &= \frac{5}{384} \cdot \frac{W \cdot L^3}{EI} \\ &= \frac{5}{384} \times \frac{45000 \times 5000^3}{1 \times 10^4 \times 4.5 \times 10^8} \\ &= \mathbf{16.27 \text{ mm. Ans.}} \end{aligned}$$

**Problem 12.6.** A beam of length 5 m and of uniform rectangular section is simply supported at its ends. It carries a uniformly distributed load of 9 kN/m run over the entire length. Calculate the width and depth of the beam if permissible bending stress is 7 N/mm<sup>2</sup> and central deflection is not to exceed 1 cm.

Take  $E$  for beam material =  $1 \times 10^4$  N/mm<sup>2</sup>.

**Sol.** Given :

Length,  $L = 5$  m = 5000 mm

U.d.l.,  $w = 9$  kN/m

\*Here  $L$  should be taken in metre. Hence for calculating total load,  $L$  must be in metre and in other calculations  $L$  is taken in mm.



$\therefore$  Total load,  $W = w.L = 9 \times 5 = 45 \text{ kN} = 45000 \text{ N}$   
 Bending stress,  $f = 7 \text{ N/mm}^2$   
 Central deflection,  $y_C = 1 \text{ cm} = 10 \text{ mm}$   
 Value of  $E = 1 \times 10^4 \text{ N/mm}^2$   
 Let  $b =$  Width of beam in mm  
 and  $d =$  Depth of beam in mm

$\therefore$  M.O.I.,  $I = \frac{bd^3}{12}$   
 Using equation (12.14), we get

$$y_C = \frac{5}{384} \cdot \frac{W \cdot L^3}{EI}$$

or  $10 = \frac{5}{384} \times \frac{45000 \times 5000^3}{1 \times 10^4 \times \left(\frac{bd^3}{12}\right)}$

or  $bd^3 = \frac{5}{384} \times \frac{45000 \times 5000^3 \times 12}{1 \times 10^4 \times 10}$   
 $= 878.906 \times 10^7 \text{ mm}^4 \quad \dots(i)$

The maximum bending moment for a simply supported beam carrying a uniformly distributed load is given by,

$$M = \frac{w \cdot L^2}{8} = \frac{W \cdot L}{8} \quad (\because W = w.L = \text{Total load})$$

$$= \frac{45000 \times 5}{8} \text{ Nm} = \frac{45000 \times 5}{8} \times 1000 \text{ Nmm}$$

$$= 28125000 \text{ Nmm}$$

Now using the bending equation as

$$\frac{M}{I} = \frac{f}{y}$$

or  $\frac{28125000}{\left(\frac{bd^3}{12}\right)} = \frac{7}{\left(\frac{d}{2}\right)} \quad (\because \text{Here } y = \frac{d}{2})$

or  $\frac{28125000 \times 12}{bd^3} = \frac{14}{d}$

or  $bd^2 = \frac{28125000 \times 12}{14} = 24107142.85 \text{ mm}^3 \quad \dots(ii)$

Dividing equation (i) by equation (ii), we get

$$d = \frac{878.906 \times 10^7}{24107142.85} = 364.58 \text{ mm. Ans.}$$

Substituting this value of 'd' in equation (ii), we get

$$b \times (364.58)^2 = 24107142.85$$

$\therefore b = \frac{24107142.85}{364.58^2} = 181.36 \text{ mm. Ans.}$

**Problem 12.7.** A beam of length 5 m and of uniform rectangular section is supported at its ends and carries uniformly distributed load over the entire length. Calculate the depth of the section if the maximum permissible bending stress is  $8 \text{ N/mm}^2$  and central deflection is not to exceed 10 mm.

Take the value of  $E = 1.2 \times 10^4 \text{ N/mm}^2$ .

**Sol.** Given :

Length,  $L = 5 \text{ m} = 5000 \text{ mm}$

Bending stress,  $f = 8 \text{ N/mm}^2$

Central deflection,  $y_C = 10 \text{ mm}$

Value of  $E = 1.2 \times 10^4 \text{ N/mm}^2$

Let  $W =$  Total load

and  $d =$  Depth of beam

The maximum bending moment for a simply supported beam carrying a uniformly distributed load is given by,

$$M = \frac{w \cdot L^2}{8} = \frac{W \cdot L}{8} \quad (\because W = w.L) \quad \dots(i)$$

Now using the bending equation,

$$\frac{M}{I} = \frac{f}{y}$$

or  $M = \frac{f \times I}{y} = \frac{8 \times I}{(d/2)} \quad (\because y = \frac{d}{2})$

$\therefore M = \frac{16I}{d} \quad \dots(ii)$

Equating the two values of B.M., we get

$$\frac{W \cdot L}{8} = \frac{16I}{d}$$

or  $W = \frac{16 \times 8I}{L \times d} = \frac{128I}{L \times d} \quad \dots(iii)$

Now using equation (12.14), we get

$$y_C = \frac{5}{384} \times \frac{WL^3}{EI}$$

or  $10 = \frac{5}{384} \times \frac{128I}{L \times d} \times \frac{L^3}{EI} \quad (\because y_C = 10 \text{ mm and } W = \frac{128I}{L \times d})$

$$= \frac{5}{384} \times \frac{128 \times L^2}{d \times E}$$

or  $d = \frac{5}{384} \times \frac{128 \times L^2}{10 \times E} = \frac{5}{384} \times \frac{128 \times 5000^2}{10 \times 1.2 \times 10^4}$   
 $= 347.2 \text{ mm} = 34.72 \text{ cm. Ans.}$

## 12.7. MACAULAY'S METHOD

The procedure of finding slope and deflection for a simply supported beam with an eccentric point load as mentioned in Art. 12.5, is a very laborious. There is a convenient method for determining the deflections of the beam subjected to point loads.

This method was devised by Mr. M.H. Macaulay and is known as Macaulay's method. This method mainly consists in the special manner in which the bending moment at any section is expressed and in the manner in which the integrations are carried out.

**12.7.1. Deflection of a Simply Supported Beam with an Eccentric Point Load.** A simply supported beam AB of length L and carrying a point load W at a distance 'a' from left support and at a distance 'b' from right support is shown in Fig. 12.7. The reactions at A and B are given by,

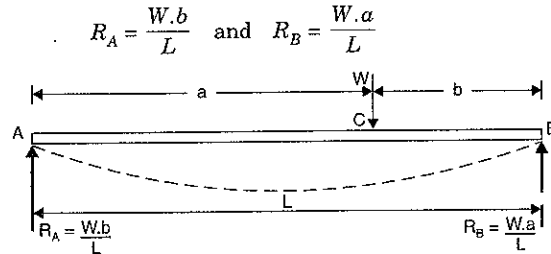

Fig. 12.7

The bending moment at any section between A and C at a distance x from A is given by,

$$M_x = R_A \times x = \frac{W.b}{L} \times x$$

The above equation of B.M. holds good for the values of x between 0 and 'a'. The B.M. at any section between C and B at a distance x from A is given by,

$$M_x = R_A \cdot x - W \times (x - a) = \frac{W.b}{L} \cdot x - W(x - a)$$

The above equation of B.M. holds good for all values of x between x = a and x = b.

The B.M. for all sections of the beam can be expressed in a single equation written as

$$M_x = \frac{W.b}{L} x \dots - W(x - a) \dots (i)$$

Stop at the dotted line for any point in section AC. But for any point in section CB, add the expression beyond the dotted line also.

The B.M. at any section is also given by equation (12.3) as

$$M = EI \frac{d^2 y}{dx^2} \dots (ii)$$

Hence equating (i) and (ii), we get

$$EI \frac{d^2 y}{dx^2} = \frac{W.b}{L} \cdot x \dots - W(x - a) \dots (iii)$$

Integrating the above equation, we get

$$EI \frac{dy}{dx} = \frac{W.b}{L} \frac{x^2}{2} + C_1 \dots - \frac{W(x - a)^2}{2} \dots (iv)$$

where C<sub>1</sub> is a constant of integration. This constant of integration should be written after the first term. Also the brackets are to be integrated as a whole. Hence the integration of (x - a) will be  $\frac{(x - a)^2}{2}$  and not  $\frac{x^2}{2} - ax$ .

Integrating equation (iv) once again, we get

$$EIy = \frac{W.b}{2L} \cdot \frac{x^3}{3} + C_1 x + C_2 \dots - \frac{W(x - a)^3}{6} \dots (v)$$

where C<sub>2</sub> is another constant of integration. This constant is written after C<sub>1</sub>x. The integration of (x - a)<sup>2</sup> will be  $\left(\frac{x - a}{3}\right)^3$ . This type of integration is justified as the constant of integrations C<sub>1</sub> and C<sub>2</sub> are valid for all values of x.

The values of C<sub>1</sub> and C<sub>2</sub> are obtained from boundary conditions. The two boundary conditions are :

(i) At x = 0, y = 0 and (ii) At x = L, y = 0

(i) At A, x = 0 and y = 0. Substituting these values in equation (v) upto dotted line only, we get

$$0 = 0 + 0 + C_2$$

$$\therefore C_2 = 0$$

(ii) At B, x = L and y = 0. Substituting these values in equation (v), we get

$$0 = \frac{W.b}{2L} \cdot \frac{L^3}{3} + C_1 \times L + 0 - \frac{W(L - a)^3}{6} \quad (\because C_2 = 0. \text{ Here complete Eq. (v) is to be taken})$$

$$= \frac{W.b.L^2}{6} + C_1 \times L - \frac{W.b^3}{6} \quad (\because L - a = b)$$

$$\therefore C_1 \times L = \frac{W}{6} \cdot b^3 - \frac{W.b.L^2}{6} = -\frac{W.b}{6} (L^2 - b^2)$$

$$\therefore C_1 = -\frac{W.b}{6L} (L^2 - b^2) \dots (vi)$$

Substituting the value of C<sub>1</sub> in equation (iv), we get

$$EI \frac{dy}{dx} = \frac{W.b}{L} \frac{x^2}{2} + \left[ -\frac{W.b}{6L} (L^2 - b^2) \right] \dots - \frac{W(x - a)^2}{2} \dots (vii)$$

The equation (vii) gives the slope at any point in the beam. Slope is maximum at A or B. To find the slope at A, substitute x = 0 in the above equation upto dotted line as point A lies in AC.

$$\therefore EI \theta_A = \frac{W.b}{2L} \times 0 - \frac{Wb}{6L} (L^2 - b^2) \quad \left( \because \frac{dy}{dx} \text{ at } A = \theta_A \right)$$

$$= -\frac{Wb}{6L} (L^2 - b^2)$$

$$\therefore \theta_A = -\frac{Wb}{6EI} (L^2 - b^2) \quad (\text{as given before})$$

Substituting the values of  $C_1$  and  $C_2$  in equation (v), we get

$$EIy = \frac{W \cdot b}{6L} \cdot x^3 + \left[ -\frac{Wb}{6L}(L^2 - b^2) \right] x + 0 \quad \dots (viii)$$

The equation (viii) gives the deflection at any point in the beam. To find the deflection  $y_c$  under the load, substitute  $x = a$  in equation (viii) and consider the equation upto dotted line (as point C lies in AC). Hence, we get

$$\begin{aligned} EIy_c &= \frac{W \cdot b}{6L} \cdot a^3 - \frac{W \cdot b}{6L} (L^2 - b^2)a = \frac{W \cdot b}{6L} \cdot a (a^2 - L^2 + b^2) \\ &= -\frac{W \cdot a \cdot b}{6L} (L^2 - a^2 - b^2) \\ &= -\frac{W \cdot a \cdot b}{6L} \{ (a+b)^2 - a^2 - b^2 \} \quad (\because L = a+b) \\ &= -\frac{W \cdot a \cdot b}{6L} [a^2 + b^2 + 2ab - a^2 - b^2] \\ &= -\frac{W \cdot a \cdot b}{6L} [2ab] = -\frac{Wa^2 \cdot b^2}{3L} \\ \therefore y_c &= -\frac{Wa^2 \cdot b^2}{3EIL} \quad \dots (\text{same as before}) \end{aligned}$$

**Note.** While using Macaulay's Method, the section  $x$  is to be taken in the last portion of the beam.

**Problem 12.8.** A beam of length 6 m is simply supported at its ends and carries a point load of 40 kN at a distance of 4 m from the left support. Find the deflection under the load and maximum deflection. Also calculate the point at which maximum deflection takes place. Given M.O.I. of beam =  $7.33 \times 10^7 \text{ mm}^4$  and  $E = 2 \times 10^5 \text{ N/mm}^2$ .

**Sol. Given :**

Length,  $L = 6 \text{ m} = 6000 \text{ mm}$

Point load,  $W = 40 \text{ kN} = 40,000 \text{ N}$

Distance of point load from left support,  $a = 4 \text{ m} = 4000 \text{ mm}$

$\therefore b = L - a = 6 - 4 = 2 \text{ m} = 2000 \text{ mm}$

Let  $y_c =$  Deflection under the load

$y_{max} =$  Maximum deflection

Using equation  $y_c = -\frac{W \cdot a^2 \cdot b^2}{3EIL}$

$$\begin{aligned} \therefore y_c &= -\frac{40000 \times 4000^2 \times 2000^2}{3 \times 2 \times 10^5 \times 7.33 \times 10^7 \times 6000} \\ &= -9.7 \text{ mm. Ans.} \end{aligned}$$

**Problem 12.9.** A beam of length 6 m is simply supported at its ends and carries two point loads of 48 kN and 40 kN at a distance of 1 m and 3 m respectively from the left support. Find :

(i) deflection under each load,

(ii) maximum deflection, and

(iii) the point at which maximum deflection occurs.

Given  $E = 2 \times 10^5 \text{ N/mm}^2$  and  $I = 85 \times 10^6 \text{ mm}^4$ .

**Sol. Given :**

$$I = 85 \times 10^6 \text{ mm}^4 ; E = 2 \times 10^5 \text{ N/mm}^2$$

First calculate the reactions  $R_A$  and  $R_B$ .

Taking moments about A, we get

$$R_B \times 6 = 48 \times 1 + 40 \times 3 = 168$$

$$\therefore R_B = \frac{168}{6} = 28 \text{ kN}$$

$$\therefore R_A = \text{Total load} - R_B = (48 + 40) - 28 = 60 \text{ kN}$$

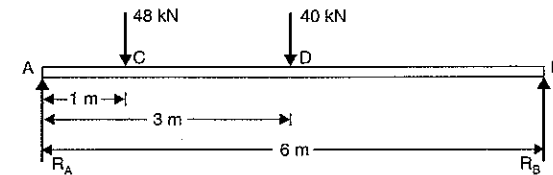

Fig. 12.8

Consider the section X in the last part of the beam (i.e., in length DB) at a distance  $x$  from the left support A. The B.M. at this section is given by,

$$\begin{aligned} EI \frac{d^2y}{dx^2} &= R_A \cdot x \quad \dots - 48(x-1) \quad \dots - 40(x-3) \\ &= 60x \quad \dots - 48(x-1) \quad \dots - 40(x-3) \end{aligned}$$

Integrating the above equation, we get

$$\begin{aligned} EI \frac{dy}{dx} &= \frac{60x^2}{2} + C_1 \quad \dots - 48 \frac{(x-1)^2}{2} \quad \dots - 40 \frac{(x-3)^2}{2} \\ &= 30x^2 + C_1 \quad \dots - 24(x-1)^2 \quad \dots - 20(x-3)^2 \quad \dots (i) \end{aligned}$$

Integrating the above equation again, we get

$$\begin{aligned} EIy &= \frac{30x^3}{3} + C_1x + C_2 \quad \dots - \frac{24(x-1)^3}{3} \quad \dots - \frac{20(x-3)^3}{3} \\ &= 10x^3 + C_1x + C_2 \quad \dots - 8(x-1)^3 \quad \dots - \frac{20}{3}(x-3)^3 \quad \dots (ii) \end{aligned}$$

To find the values of  $C_1$  and  $C_2$ , use two boundary conditions. The boundary conditions are :

(i) at  $x = 0, y = 0$ , and (ii) at  $x = 6 \text{ m}, y = 0$ .

(i) Substituting the first boundary condition i.e., at  $x = 0, y = 0$  in equation (ii) and considering the equation upto first dotted line (as  $x = 0$  lies in the first part of the beam), we get

$$0 = 0 + 0 + C_2 \quad \therefore C_2 = 0$$

(ii) Substituting the second boundary condition i.e., at  $x = 6 \text{ m}, y = 0$  in equation (ii) and considering the complete equation (as  $x = 6$  lies in the last part of the beam), we get

$$0 = 10 \times 6^3 + C_1 \times 6 + 0 - 8(6-1)^3 - \frac{20}{3}(6-3)^3 \quad (\because C_2 = 0)$$

$$\text{or } 0 = 2160 + 6C_1 - 8 \times 5^3 - \frac{20}{3} \times 3^3$$

$$= 2160 + 6C_1 - 1000 - 180 = 980 + 6C_1$$

$$\therefore C_1 = \frac{-980}{6} = -163.33$$

Now substituting the values of  $C_1$  and  $C_2$  in equation (ii), we get

$$EIy = 10x^3 - 163.33x \quad \vdots \quad -8(x-1)^3 \quad \vdots \quad -\frac{20}{3}(x-3)^3 \quad \dots(iii)$$

(i) (a) Deflection under first load i.e., at point C. This is obtained by substituting  $x = 1$  in equation (iii) upto the first dotted line (as the point C lies in the first part of the beam). Hence, we get

$$\begin{aligned} EI.y_c &= 10 \times 1^3 - 163.33 \times 1 \\ &= 10 - 163.33 = -153.33 \text{ kNm}^3 \\ &= -153.33 \times 10^3 \text{ Nm}^3 \\ &= -153.33 \times 10^3 \times 10^9 \text{ Nmm}^3 \\ &= -153.33 \times 10^{12} \text{ Nmm}^3 \end{aligned}$$

$$\therefore y_c = \frac{-153.33 \times 10^{12}}{EI} = \frac{-153.33 \times 10^{12}}{2 \times 10^5 \times 85 \times 10^6} \text{ mm}$$

$$= -9.019 \text{ mm. Ans.}$$

(Negative sign shows that deflection is downwards).

(b) Deflection under second load i.e., at point D. This is obtained by substituting  $x = 3$  m in equation (iii) upto the second dotted line (as the point D lies in the second part of the beam). Hence, we get

$$\begin{aligned} EI.y_D &= 10 \times 3^3 - 163.33 \times 3 - 8(3-1)^3 \\ &= 270 - 489.99 - 64 = -283.99 \text{ kNm}^3 \\ &= -283.99 \times 10^{12} \text{ Nmm}^3 \end{aligned}$$

$$\therefore y_D = \frac{-283.99 \times 10^{12}}{2 \times 10^5 \times 85 \times 10^6} = -16.7 \text{ mm. Ans.}$$

(ii) Maximum Deflection. The deflection is likely to be maximum at a section between C and D. For maximum deflection,  $\frac{dy}{dx}$  should be zero. Hence equate the equation (i) equal to zero upto the second dotted line.

$$\begin{aligned} \therefore 30x^2 + C_1 - 24(x-1)^2 &= 0 \\ \text{or } 30x^2 - 163.33 - 24(x^2 + 1 - 2x) &= 0 \quad (\because C_1 = -163.33) \\ \text{or } 6x^2 + 48x - 187.33 &= 0 \end{aligned}$$

The above equation is a quadratic equation. Hence its solution is

$$x = \frac{-48 \pm \sqrt{48^2 + 4 \times 6 \times 187.33}}{2 \times 6} = 2.87 \text{ m.}$$

(Neglecting -ve root)

Now substituting  $x = 2.87$  m in equation (iii) upto the second dotted line, we get maximum deflection as

$$\begin{aligned} EI.y_{max} &= 10 \times 2.87^3 - 163.33 \times 2.87 - 8(2.87-1)^3 \\ &= 236.39 - 468.75 - 52.31 \\ &= 284.67 \text{ kNm}^3 = -284.67 \times 10^{12} \text{ Nmm}^3 \end{aligned}$$

$$\therefore y_{max} = \frac{-284.67 \times 10^{12}}{2 \times 10^5 \times 85 \times 10^6} = -16.745 \text{ mm. Ans.}$$

**Problem 12.10.** A beam of length 8 m is simply supported at its ends. It carries a uniformly distributed load of 40 kN/m as shown in Fig. 12.9. Determine the deflection of the beam at its mid-point and also the position of maximum deflection and maximum deflection. Take  $E = 2 \times 10^5 \text{ N/mm}^2$  and  $I = 4.3 \times 10^8 \text{ mm}^4$ .

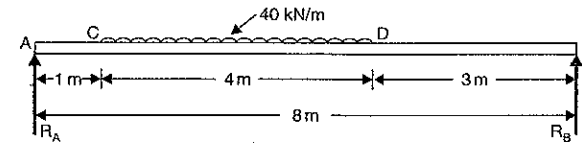

Fig. 12.9

**Sol. Given :**

$$\begin{aligned} \text{Length, } L &= 8 \text{ m} \\ \text{U.d.l., } W &= 40 \text{ kN/m} \\ \text{Value of } E &= 2 \times 10^5 \text{ N/mm}^2 \\ \text{Value of } I &= 4.3 \times 10^8 \text{ mm}^4 \end{aligned}$$

First calculate the reactions  $R_A$  and  $R_B$ .

Taking moments about A, we get

$$R_B \times 8 = 40 \times 4 \times \left(1 + \frac{4}{2}\right) = 480 \text{ kN}$$

$$\therefore R_B = \frac{480}{8} = 60 \text{ kN}$$

$$\therefore R_A = \text{Total load} - R_B = 40 \times 4 - 60 = 100 \text{ kN}$$

In order to obtain the general expression for the bending moment at a distance  $x$  from the left end A, which will apply for all values of  $x$ , it is necessary to extend the uniformly distributed load upto the support B, compensating with an equal upward load of 40 kN/m over the span DB as shown in Fig. 12.10. Now Macaulay's method can be applied.

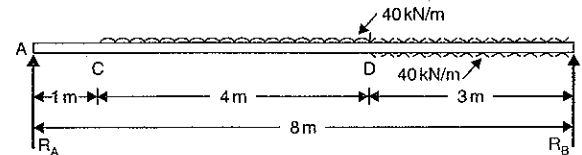

Fig. 12.10

The B.M. at any section at a distance  $x$  from end A is given by,

$$EI \frac{d^2y}{dx^2} = R_A x \quad \vdots \quad -40(x-1) \times \frac{(x-1)}{2} \quad \vdots \quad +40 \times (x-5) \times \frac{(x-5)}{2}$$

$$\text{or } EI \frac{d^2y}{dx^2} = 100x \quad \vdots \quad -20(x-1)^2 \quad \vdots \quad +20(x-5)^2$$

Integrating the above equation, we get

$$EI \frac{dy}{dx} = \frac{100x^2}{2} + C_1 \quad \vdots \quad -\frac{20(x-1)^3}{3} \quad \vdots \quad +20 \frac{(x-5)^3}{3} \quad \dots(i)$$

Integrating again, we get

$$EIy = 50 \frac{x^3}{3} + C_1x + C_2 \quad \vdots \quad -\frac{20}{3} \frac{(x-1)^4}{4} \quad \vdots \quad +\frac{20}{3} \frac{(x-5)^4}{3}$$

$$= 50 \frac{x^3}{3} + C_1x + C_2 \quad \vdots \quad -\frac{5}{3} (x-1)^4 \quad \vdots \quad +\frac{5}{3} (x-5)^4 \quad \dots(ii)$$

where  $C_1$  and  $C_2$  are constants of integration. Their values are obtained from boundary conditions which are:

$$(i) \text{ at } x = 0, y = 0 \quad \text{and} \quad (ii) \text{ at } x = 8 \text{ m}, y = 0$$

(i) Substituting  $x = 0$  and  $y = 0$  in equation (ii) upto first dotted line (as  $x = 0$  lies in the first part AC of the beam), we get

$$0 = 0 + C_1 \times 0 + C_2 \quad \therefore C_2 = 0$$

(ii) Substituting  $x = 8$  and  $y = 0$  in complete equation (ii) (as point  $x = 8$  lies in the last part DB of the beam), we get

$$0 = \frac{50}{3} \times 8^3 + C_1 \times 8 + 0 - \frac{5}{3} (8-1)^4 + \frac{5}{3} (8-5)^4 \quad (\because C_2 = 0)$$

$$= 8533.33 + 8C_1 - 4001.66 + 135$$

$$\text{or} \quad 8C_1 = -4666.67$$

$$\text{or} \quad C_1 = \frac{-4666.67}{8} = -583.33$$

Substituting the value of  $C_1$  and  $C_2$  in equation (ii), we get

$$EIy = \frac{50}{3} x^3 - 583.33x \quad \vdots \quad -\frac{5}{3} (x-1)^4 \quad \vdots \quad +\frac{5}{3} (x-4)^4 \quad \dots(iii)$$

(a) Deflection at the centre

By substituting  $x = 4$  m in equation (iii) upto second dotted line, we get the deflection at the centre. [The point  $x = 4$  lies in the second part (i.e., CD) of the beam].

$$\therefore EIy = \frac{50}{3} \times 4^3 - 583.33 \times 4 - \frac{5}{3} (4-1)^4$$

$$= 1066.66 - 2333.32 - 135 = -1401.66 \text{ kNm}^3$$

$$= -1401.66 \times 1000 \text{ Nm}^3$$

$$= -1401.66 \times 1000 \times 10^9 \text{ Nmm}^3$$

$$= -1401.66 \times 10^{12} \text{ Nmm}^3$$

$$\therefore y = \frac{-1401.66 \times 10^{12}}{EI} = \frac{-1401.66 \times 10^{12}}{2 \times 10^5 \times 4.5 \times 10^8}$$

$$= -16.29 \text{ mm downward. Ans.}$$

(b) Position of maximum deflection

The maximum deflection is likely to lie between C and D. For maximum deflection the slope  $\frac{dy}{dx}$  should be zero. Hence equating the slope given by equation (i) upto second dotted line to zero, we get

$$0 = 100 \frac{x^2}{2} + C_1 - \frac{20}{3} (x-1)^3$$

$$0 = 50x^2 - 583.33 - 6.667(x-1)^3 \quad \dots(iv)$$

The above equation is solved by trial and error method.

Let  $x = 1$ , then R.H.S. of equation (iv)

$$= 50 - 583.33 - 6.667 \times 0 = -533.33$$

$$\text{Let } x = 2, \text{ then R.H.S.} = 50 \times 4 - 583.33 - 6.667 \times 1 = -390.00$$

$$\text{Let } x = 3, \text{ then R.H.S.} = 50 \times 9 - 583.33 - 6.667 \times 8 = -136.69$$

$$\text{Let } x = 4, \text{ then R.H.S.} = 50 \times 16 - 583.33 - 6.667 \times 27 = +36.58$$

In equation (iv), when  $x = 3$  then R.H.S. is negative but when  $x = 4$  then R.H.S. is positive. Hence exact value of  $x$  lies between 3 and 4.

$$\text{Let } x = 3.82, \text{ then R.H.S.} = 50 \times 3.82 - 583.33 - 6.667 (3.82 - 1)^3$$

$$= 729.63 - 583.33 - 149.51 = -3.22$$

$$\text{Let } x = 3.83, \text{ then R.H.S.} = 50 \times 3.83^2 - 583.33 = 6.667 (3.83 - 1)^3$$

$$= 733.445 - 583.33 - 151.1 = -0.99$$

The R.H.S. is approximately zero in comparison to the three terms (i.e., 733.445, 583.33 and 151.1).

$\therefore$  Value of  $x = 3.83$ . Ans.

Hence maximum deflection will be at a distance of 3.83 m from support A.

(c) Maximum deflection

Substituting  $x = 3.83$  m in equation (iii) upto second dotted line, we get the maximum deflection [the point  $x = 3.83$  lies in the second part i.e., CD of the beam.]

$$\therefore EIy_{\max} = \frac{50}{3} \times 3.83^3 - 583.33 \times 3.83 - \frac{5}{3} (3.83 - 1)^4$$

$$= 936.36 - 2234.15 - 106.9 = -1404.69 \text{ kNm}^3$$

$$= -1404.69 \times 10^{12} \text{ Nmm}^3$$

$$\therefore y_{\max} = \frac{-1404.69 \times 10^{12}}{2 \times 10^5 \times 4.3 \times 10^8} = -16.33 \text{ mm. Ans.}$$

**Problem 12.11.** An overhanging beam ABC is loaded as shown in Fig. 12.11. Find the slopes over each support and at the right end. Find also the maximum upward deflection between the supports and the deflection at the right end.

Take  $E = 2 \times 10^5 \text{ N/mm}^2$  and  $I = 5 \times 10^8 \text{ mm}^4$ .

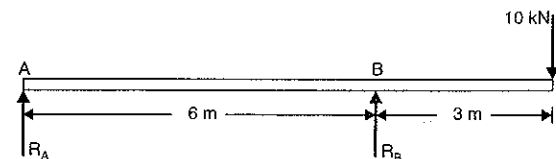

Fig. 12.11

Sol. Given :

$$\text{Point load,} \quad W = 10 \text{ kN}$$

$$\text{Value of} \quad E = 2 \times 10^5 \text{ N/mm}^2$$

$$\text{Value of} \quad I = 5 \times 10^8 \text{ mm}^4$$

First calculate the reaction  $R_A$  and  $R_B$ .

Taking moments about A, we get

$$R_B \times 6 = 10 \times 9$$

$$R_B = \frac{10 \times 9}{6} = 15 \text{ kN}$$

$$R_A = \text{Total load} - R_B = 10 - 15 = -5 \text{ kN}$$

Hence the reaction  $R_A$  will be in the downward direction. Hence Fig. 12.11 will be modified as shown in Fig. 12.12. Now write down an expression for the B.M. in the last section of the beam.

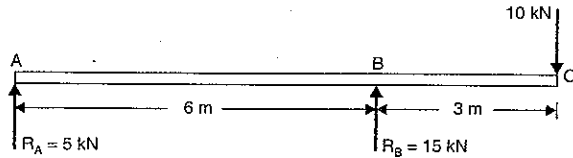

Fig. 12.12

The B.M. at any section at a distance  $x$  from the support A is given by,

$$\begin{aligned} EI \frac{d^2y}{dx^2} &= -R_A \times x \quad \dots + R_B \times (x-6) \\ &= -5x \quad \dots + 15(x-6) \end{aligned} \quad (\because R_A = 5)$$

Integrating the above equation, we get

$$EI \frac{dy}{dx} = \frac{-5x^2}{2} + C_1 \quad \dots + \frac{15(x-6)^2}{2} \quad \dots(i)$$

Integrating again, we get

$$\begin{aligned} EIy &= -\frac{5x^3}{6} + C_1x + C_2 \quad \dots + \frac{15(x-6)^3}{6} \\ &= -\frac{5}{6}x^3 + C_1x + C_2 \quad \dots + \frac{5}{2}(x-6)^3 \end{aligned} \quad \dots(ii)$$

where  $C_1$  and  $C_2$  are constant of integration. Their values are obtained from boundary conditions which are :

(i) at  $x = 0, y = 0$  and

(ii) at  $x = 6 \text{ m}, y = 0$ .

(i) Substituting  $x = 0$  and  $y = 0$  in equation (ii) upto dotted line (as  $x = 0$  lies in the first part AB of the beam), we get

$$0 = 0 + C_1 \times 0 + C_2 \quad \therefore C_2 = 0$$

(ii) Substituting  $x = 6 \text{ m}$  and  $y = 0$  in equation (ii) upto dotted line (as  $x = 6$  lies in the first part AB of the beam), we get

$$0 = -\frac{5}{6} \times 6^3 + C_1 \times 6 + 0 \quad (\because C_2 = 0)$$

$$= -5 \times 36 + 6C_1$$

$$C_1 = \frac{+5 \times 36}{6} = 30$$

Substituting the values of  $C_1$  and  $C_2$  in equations (i) and (ii), we get

$$EI \frac{dy}{dx} = -\frac{5}{2}x^2 + 30 \quad \dots + \frac{15}{2}(x-6)^2 \quad \dots(iii)$$

$$EIy = -\frac{5}{6}x^3 + 30x \quad \dots + \frac{5}{2}(x-6)^3 \quad \dots(iv)$$

(a) Slope over the support A

By substituting  $x = 0$  in equation (iii) upto dotted line, we get the slope at support A (the point  $x = 0$  lies in the first part AB of the beam).

$$\begin{aligned} \therefore EI\theta_A &= -\frac{5}{2} \times 0 + 30 = 30 \text{ kNm}^2 = 30 \times 1000 \text{ Nm}^2 \left( \because \frac{dy}{dx} \text{ at } A = \theta_A \right) \\ &= 30 \times 1000 \times 10^6 \text{ Nmm}^2 = 30 \times 10^9 \text{ Nmm}^2 \\ \therefore \theta_A &= \frac{30 \times 10^9}{E \times I} = \frac{30 \times 10^9}{2 \times 10^5 \times 5 \times 10^8} \\ &= 0.0003 \text{ radians. Ans.} \end{aligned}$$

(b) Slope at the support B

By substituting  $x = 6 \text{ m}$  in equation (iii) upto dotted line, we get the slope at support B (the point  $x = 6$  lies in the first part AB of the beam).

$$\begin{aligned} EI\theta_B &= -\frac{5}{2} \times 6^2 + 30 = -90 + 30 \quad \left( \because \frac{dy}{dx} \text{ at } B = \theta_B \right) \\ &= -60 \text{ kNm}^2 = -60 \times 10^9 \text{ Nmm}^2 \\ \therefore \theta_B &= \frac{-60 \times 10^9}{E \times I} = \frac{-60 \times 10^9}{2 \times 10^5 \times 5 \times 10^8} \\ &= -0.0006 \text{ radians. Ans.} \end{aligned}$$

(c) Slope at the right end i.e., at C

By substituting  $x = 9 \text{ m}$  in equation (iii), we get the slope at C. In this case, complete equation is to be taken as point  $x = 9 \text{ m}$  lies in the last part of the beam.

$$\begin{aligned} \therefore EI\theta_C &= -\frac{5}{2} \times 9^2 + 30 + \frac{15}{2}(9-6)^2 \quad \left( \because \frac{dy}{dx} \text{ at } C = \theta_C \right) \\ &= -202.5 + 30 + 67.5 = -105 \text{ kNm}^2 \\ &= -105 \times 10^9 \text{ Nmm}^2 \\ \therefore \theta_C &= \frac{-105 \times 10^9}{E \times I} = \frac{-105 \times 10^9}{2 \times 10^5 \times 5 \times 10^8} \\ &= -0.00105 \text{ radians. Ans.} \end{aligned}$$

(d) Maximum upward deflection between the supports

For maximum deflection between the supports,  $\frac{dy}{dx}$  should be zero. Hence equating the slope given by the equation (iii) to be zero upto dotted line, we get

$$0 = -\frac{5}{2}x^2 + 30 = -5x^2 + 60$$

$$\text{or } 5x^2 = 60 \quad \text{or } x = \sqrt{\frac{60}{5}} = \sqrt{12} = 3.464 \text{ m}$$

Now substituting  $x = 3.464 \text{ m}$  in equation (iv) upto dotted line, we get the maximum deflection as

$$EIy_{max} = -\frac{5}{6} \times 3.464^3 + 30 \times 3.464$$

$$= -34.638 + 103.92 = 69.282 \text{ kNm}^3$$

$$= 69.282 \times 1000 \times 10^9 \text{ Nmm}^3 = 69.282 \times 10^{12} \text{ mm}^3$$

$$\therefore y_{\max} = \frac{69.282 \times 10^{12}}{2 \times 10^5 \times 5 \times 10^8}$$

$$= 0.6928 \text{ mm (upward). Ans.}$$

(e) Deflection at the right end i.e., at point C

By substituting  $x = 9 \text{ m}$  in equation (iv), we get the deflection at point C. Here complete equation is to be taken as point  $x = 9 \text{ m}$  lies in the last part of the beam.

$$\therefore EI y_C = -\frac{5}{6} \times 9^3 + 30 \times 9 + \frac{5}{2} (9-6)^3$$

$$= -607.5 + 270 + 67.5$$

$$= -270 \text{ kNm}^3 = -270 \times 10^{12} \text{ Nmm}^3$$

$$\therefore y_C = \frac{-270 \times 10^{12}}{2 \times 10^5 \times 5 \times 10^8}$$

$$= -2.7 \text{ mm (downwards). Ans.}$$

**Problem 12.12.** A beam ABC of length 9 m has one support of the left end and the other support at a distance of 6 m from the left end. The beam carries a point load of 12 kN at right end and also carries a uniformly distributed load of 4 kN/m over a length of 3 m as shown in Fig. 12.13. Determine the slope and deflection at point C.

Take  $E = 2 \times 10^5 \text{ N/mm}^2$  and  $I = 5 \times 10^8 \text{ mm}^4$ .

**Sol.** Given :

Point load,  $W = 12 \text{ kN}$   
 U.d.l.,  $w = 4 \text{ kN/m}$   
 Value of  $E = 2 \times 10^5 \text{ N/mm}^2$   
 Value of  $I = 5 \times 10^8 \text{ mm}^4$   
 First calculate the reactions  $R_A$  and  $R_B$ .

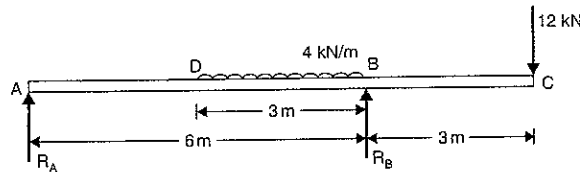

Fig. 12.13

Taking moments about A, we get

$$R_B \times 6 = 4 \times 3 \times \left(3 + \frac{3}{2}\right) + 12 \times 9$$

$$= 54 + 108 = 162$$

$$\therefore R_B = \frac{162}{6} = 27 \text{ kN } (\uparrow)$$

and

$$R_A = \text{Total load} - R_B = 24 - 27 = -3 \text{ kN } (\downarrow)$$

Negative sign shows that  $R_A$  will be acting downwards. In order to obtain general expression for the bending moment at a distance  $x$  from the left end A, which will apply for all values of  $x$ , it is necessary to extend the uniformly distributed load upto point C, compensating with an equal upward load of 4 kN/m over the span BC as shown in Fig. 12.14. Now Macaulay's method can be applied.

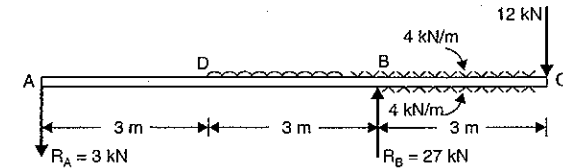

Fig. 12.14

The B.M. at any section at a distance  $x$  from the support A is given by,

$$EI \frac{d^2 y}{dx^2} = -R_A \times x \quad \vdots \quad -4(x-3) \frac{(x-3)}{2} \quad \vdots \quad +R_B(x-6) \quad \vdots \quad +4(x-6) \frac{(x-6)}{2}$$

$$= -3x \quad \vdots \quad -2(x-3)^2 \quad \vdots \quad +27(x-6) \quad \vdots \quad +2(x-6)^2$$

Integrating the above equation, we get

$$EI \frac{dy}{dx} = -\frac{3x^2}{2} + C_1 \quad \vdots \quad -\frac{2(x-3)^3}{3} \quad \vdots \quad +\frac{27(x-6)^2}{2} + \frac{2(x-6)^3}{3} \quad \dots(i)$$

Integrating again, we get

$$EI y = -\frac{3x^3}{2 \cdot 3} + C_1 x + C_2 \quad \vdots \quad -\frac{2(x-3)^4}{3 \cdot 4} \quad \vdots \quad +\frac{27(x-6)^3}{2 \cdot 3} \quad \vdots \quad +\frac{2(x-6)^4}{3 \cdot 4}$$

or

$$EI y = -\frac{x^3}{2} + C_1 x + C_2 \quad \vdots \quad -\frac{(x-3)^4}{6} \quad \vdots \quad +\frac{9}{2}(x-6)^3 \quad \vdots \quad +\frac{1}{6}(x-6)^4 \quad \dots(ii)$$

where  $C_1$  and  $C_2$  are constant of integration. Their values are obtained from boundary conditions which are :

(i) at  $x = 0, y = 0$  and

(ii) at  $x = 6 \text{ m}, y = 0$ .

(i) Substituting the  $x = 0$  and  $y = 0$  in equation (ii) upto first dotted line (as  $x = 0$  lies in the first part AD of the beam), we get

$$0 = 0 + C_1 \times 0 + C_2 \quad \therefore C_2 = 0$$

(ii) Substituting  $x = 6$  and  $y = 0$  in equation (ii) upto second dotted line (as  $x = 6$  lies in the second part DB of the beam), we get

$$0 = -\frac{6^3}{2} + C_1 \times 6 + 0 - \frac{(6-3)^4}{6}$$

$$= -108 + 6C_1 - 13.5 = -121.5 + 6C_1$$

or

$$C_1 = \frac{121.5}{6} = 20.25$$

Substituting the values of  $C_1$  and  $C_2$  in equations (i) and (ii), we get

$$EI \frac{dy}{dx} = -\frac{3}{2} x^2 + 20.25 \quad \vdots \quad -\frac{2(x-3)^3}{3} \quad \vdots \quad +\frac{27}{2} (x-6)^2 \quad \vdots \quad +\frac{2}{3} (x-6)^3 \quad \dots(iii)$$

and

$$EI y = -\frac{x^3}{2} + 20.25 \times x \quad \vdots \quad -\frac{1}{6}(x-3)^4 \quad \vdots \quad +\frac{9}{2}(x-6)^3 \quad \vdots \quad +\frac{1}{6}(x-6)^4 \quad \dots(iv)$$

## (a) Slope at the point C

By substituting  $x = 9$  m in equation (iii), we get the slope at C. Here complete equation is to be taken as point  $x = 9$  m lies in the last part of the beam.

$$EI\theta_C = -\frac{3}{2} \times 9^2 + 20.25 - \frac{2}{3}(9-3)^3 + \frac{27}{2}(9-6)^2 + \frac{1}{3}(9-6)^3$$

$$\left( \because \frac{dy}{dx} \text{ at } C = \theta_C \right)$$

$$= -121.5 + 20.25 - 144 + 121.5 + 18 = -105.75 \text{ kNm}^2$$

$$= -105.75 \times 10^3 \times 10^6 \text{ Nmm}^2 = -105.75 \times 10^9 \text{ Nmm}^2$$

$$\therefore \theta_C = -\frac{105.75 \times 10^9}{2 \times 10^5 \times 5 \times 10^8} = -0.0010575 \text{ radians. Ans.}$$

## (b) Deflection at the point C

By substituting  $x = 9$  m in complete equation (iv), we get the deflection at C.

$$EI \times y_C = -\frac{9^3}{2} + 20.25 \times 9 - \frac{1}{6}(9-3)^4 + \frac{9}{2}(9-6)^3 + \frac{1}{6}(9-6)^4$$

$$= -364.5 + 182.25 - 216 + 121.5 + 13.5$$

$$= -263.25 \text{ kNm}^3 = -263.25 \times 10^{12} \text{ Nmm}^3$$

$$\therefore y_C = -\frac{263.25 \times 10^{12}}{2 \times 10^5 \times 5 \times 10^8} = -2.6325 \text{ mm. Ans.}$$

**Problem 12.13.** A horizontal beam AB is simply supported at A and B, 6 m apart. The beam is subjected to a clockwise couple of 300 kNm at a distance of 4 m from the left end as shown in Fig. 12.15. If  $E = 2 \times 10^5 \text{ N/mm}^2$  and  $I = 2 \times 10^8 \text{ mm}^4$ , determine:

- (i) deflection at the point where couple is acting and  
(ii) the maximum deflection.

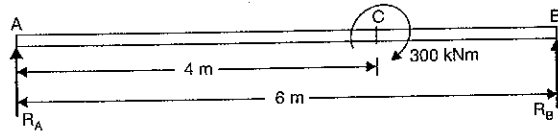

Fig. 12.15

**Sol. Given :**

Length,	$L = 6$ m
Couple	$= 300$ kNm
Value of	$E = 2 \times 10^5 \text{ N/mm}^2$
Value of	$I = 2 \times 10^8 \text{ mm}^4$

First calculate the reactions  $R_A$  and  $R_B$ .

Taking moments about A, we get

$$R_B \times 6 = 300$$

$$R_B = \frac{300}{6} = 50 \text{ kN } (\uparrow)$$

$$R_A = \text{Total load} - R_B = 0 - 50 \text{ kN } (\because \text{ There is no load on beam})$$

$$= -50 \text{ kN}$$

and

Negative sign shows that  $R_A$  is acting downwards as shown in Fig. 12.16.

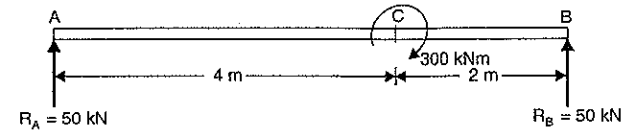

Fig. 12.16

The B.M. at any section at a distance  $x$  from A, is given by

$$EI \frac{d^2y}{dx^2} = -50x \quad \dots + 300$$

$$= -50x \quad \dots + 300(x-4)^0$$

Integrating the above equation, we get

$$EI \frac{dy}{dx} = -\frac{50x^2}{2} + C_1 \quad \dots + 300(x-4) \quad \dots (i)$$

Integrating again, we get

$$EIy = -\frac{50}{2} \times \frac{x^3}{3} + C_1x + C_2 \quad \dots + \frac{300(x-4)^2}{2}$$

$$= -\frac{25}{3}x^3 + C_1x + C_2 \quad \dots + 150(x-4)^2 \quad \dots (ii)$$

where  $C_1$  and  $C_2$  are constants of integration. Their values are obtained from boundary conditions which are :

- (i) at  $x = 0, y = 0$  and (ii) at  $x = 6$  m and  $y = 0$ .  
(i) Substituting  $x = 0$  and  $y = 0$  in equation (ii) upto dotted line, we get

$$0 = 0 + C_1 \times 0 + C_2 \therefore C_2 = 0$$

- (ii) Substituting  $x = 6$  m and  $y = 0$  in complete equation (ii), we get

$$0 = -\frac{25}{3} \times 6^3 + C_1 \times 6 + 0 + 150(6-4)^2$$

$$= -1800 + 6C_1 + 600$$

$$\therefore C_1 = \frac{1800 - 600}{6} = 200$$

Substituting the values of  $C_1$  and  $C_2$  in equation (ii), we get

$$EIy = -\frac{25}{3}x^3 + 200x \quad \dots + 150(x-4)^2 \quad (\because C_2 = 0) \dots (iii)$$

(i) Deflection at C (i.e.,  $y_C$ )

By substituting  $x = 4$  in equation (iii) upto dotted line, we get the deflection at C.

$$\therefore EI y_C = -\frac{25}{3} \times 4^3 + 200 \times 4$$

$$= -533.33 + 800 = +266.67 \text{ kNm}^3$$

$$= 266.67 \times 10^{12} \text{ Nmm}^3$$

$$\therefore y_C = \frac{266.67 \times 10^{12}}{2 \times 10^5 \times 2 \times 10^8} = 6.66 \text{ mm upwards. Ans.}$$



## (ii) Maximum deflection

First find the point where maximum deflection takes place. The maximum deflection is likely to occur in the larger segment AC of the beam. For maximum deflection  $\frac{dy}{dx}$  should be zero. Hence equating the slope given by equation (i) upto dotted line to zero, we get

$$-\frac{50}{2}x^2 + 200 = 0 \quad (\because C_1 = 200)$$

$$\text{or} \quad -25x^2 + 200 = 0$$

$$\text{or} \quad x = \sqrt{\frac{200}{25}} = 2 \times \sqrt{2} \text{ m}$$

Now substituting  $x = 2 \times \sqrt{2}$  in equation (iii) upto dotted line, we get the maximum deflection.

$$\begin{aligned} \therefore EI \times y_{max} &= -\frac{25}{3} \times (2 \times \sqrt{2})^3 + 200(2 \times \sqrt{2}) \\ &= -188.56 + 565.68 \\ &= 377.12 \text{ kNm}^3 = 377.12 \times 10^{12} \text{ Nmm}^3 \end{aligned}$$

$$\therefore y_{max} = \frac{377.12 \times 10^{12}}{2 \times 10^5 \times 2 \times 10^8} = 9.428 \text{ mm upwards. Ans.}$$

## 12.8. MOMENT AREA METHOD

Fig. 12.17 shows a beam AB carrying some type of loading, and hence subjected to bending moment as shown in Fig. 12.17 (a). Let the beam bent into  $AQ_1P_1B$  as shown in Fig. 12.17 (b).

Due to the load acting on the beam. Let A be a point of zero slope and zero deflection.

Consider an element PQ of small length  $dx$  at a distance  $x$  from B. The corresponding points on the deflected beam are  $P_1Q_1$  as shown in Fig. 12.17 (b).

Let  $R$  = Radius of curvature of deflected part  $P_1Q_1$

$d\theta$  = Angle subtended by the arc  $P_1Q_1$  at the centre O

$M$  = Bending moment between P and Q

$P_1C$  = Tangent at point  $P_1$

$Q_1D$  = Tangent at point  $Q_1$ .

The tangent at  $P_1$  and  $Q_1$  are cutting the vertical line through B at points C and D. The angle between the normals at  $P_1$  and  $Q_1$  will be equal to the angle

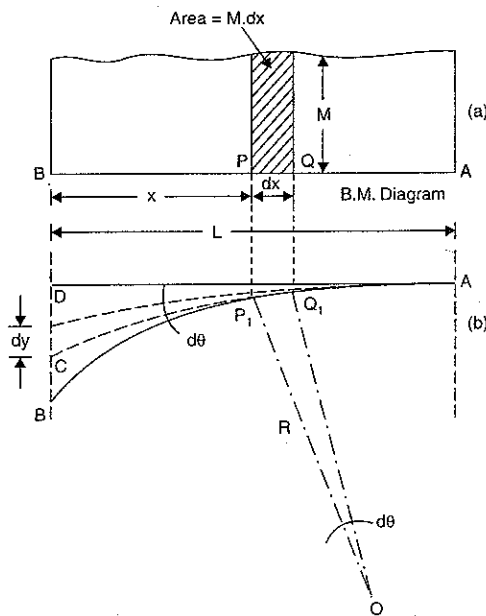

Fig. 12.17

between the tangents at  $P_1$  and  $Q_1$ . Hence the angle between the lines  $CP_1$  and  $DQ_1$  will be equal to  $d\theta$ .

For the deflected part  $P_1Q_1$  of the beam, we have

$$P_1Q_1 = R \cdot d\theta$$

$$\text{But} \quad P_1Q_1 = dx$$

$$\therefore dx = R \cdot d\theta$$

$$\therefore d\theta = \frac{dx}{R} \quad \dots(i)$$

But for a loaded beam, we have

$$\frac{M}{I} = \frac{E}{R} \quad \text{or} \quad R = \frac{EI}{M}$$

Substituting the values of  $R$  in equation (i), we get

$$d\theta = \frac{dx}{\left(\frac{EI}{M}\right)} = \frac{M \, dx}{EI} \quad \dots(ii)$$

Since the slope at point A is assumed zero, hence total slope at B is obtained by integrating the above equation between the limits 0 and L.

$$\therefore \theta = \int_0^L \frac{M \cdot dx}{EI} = \frac{1}{EI} \int_0^L M \cdot dx$$

But  $M \cdot dx$  represents the area of B. M. diagram of length  $dx$ . Hence  $\int_0^L M \cdot dx$  represents the area of B. M. diagram between A and B.

$$\therefore \theta = \frac{1}{EI} [\text{Area of B. M. diagram between A and B}]$$

$$\text{But} \quad \theta = \text{slope at B} = \theta_B$$

$\therefore$  Slope at B,

$$\theta_B = \frac{\text{Area of B. M. diagram between A and B}}{EI} \quad \dots(12.15)$$

If the slope at A is not zero then, we have

"Total change of slope between B and A is equal to the area of B. M. diagram between B and A divided by the flexural rigidity  $EI$ "

$$\text{or} \quad \theta_B - \theta_A = \frac{\text{Area of B.M. between A and B}}{EI} \quad \dots(12.16)$$

Now the deflection, due to bending of the portion  $P_1Q_1$  is given by

$$dy = x \cdot d\theta$$

Substituting the value of  $d\theta$  from equation (ii), we get

$$dy = x \cdot \frac{M \cdot dx}{EI} \quad \dots(iii)$$

Since deflection at A is assumed to be zero, hence the total deflection at B is obtained by integrating the above equation between the limits zero and L.

$$\therefore y = \int_0^L \frac{xM \cdot dx}{EI} = \frac{1}{EI} \int_0^L xM \cdot dx$$

But  $x \times M \cdot dx$  represents the moment of area of the B.M. diagram of length  $dx$  about point B.

Hence  $\int_0^L xM \cdot dx$  represents the moment of area of the B.M. diagram between  $B$  and  $A$  about  $B$ . This is equal to the total area of B.M. diagram between  $B$  and  $A$  multiplied by the distance of the C.G. of the B.M. diagram area from  $B$ .

$$\therefore y = \frac{1}{EI} \times A \times \bar{x} = \frac{A\bar{x}}{EI} \quad \dots(12.17)$$

where  $A$  = Area of B.M. diagram between  $A$  and  $B$   
 $\bar{x}$  = Distance of C.G. of the area  $A$  from  $B$ .

**12.9. MOHR'S THEOREMS**

The results given by equation (12.15) for slope and (12.17) for deflection are known as Mohr's theorems. They are state as :

- I. The change of slope between any two points is equal to the net area of the B.M. diagram between these points divided by  $EI$ .
- II. The total deflection between any two points is equal to the moment of the area of B.M. diagram between the two points about the last point (*i.e.*,  $B$ ) divided by  $EI$ .

The Mohr's theorems is conveniently used for following cases :

- 1. Problems on cantilevers (zero slope at fixed end).
- 2. Simply supported beams carrying symmetrical loading (zero slope at the centre).
- 3. Beams fixed at both ends (zero slope at each end).

The B.M. diagram is a parabola for uniformly distributed loads. The following properties of area and centroids or parabola are given as :

Let  $BC = d$   
 $AB = b$

In Fig. 12.18,  $ABC$  is a parabola and  $ABCD$  is a surrounding rectangle.

- Let  $A_1$  = Area of  $ABC$
- $\bar{x}_1$  = Distance of C.G. of  $A_1$  from  $AD$
- $A_2$  = Area of  $ACD$
- $\bar{x}_2$  = Distance of C.G. of  $A_2$  from  $AD$
- $G_1$  = C.G. of area  $A_1$
- $G_2$  = C.G. of area  $A_2$ .

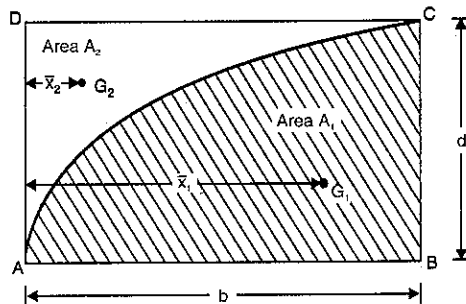

Fig. 12.18

Then  $A_1$  = Area of parabola  $ABC$   
 $= \frac{2}{3}bd$   
 $A_2$  = Area  $ACD$  = Area  $ABCD$  - Area  $ABC$   
 $= b \times d - \frac{2}{3}bd = \frac{1}{3}bd$   
 $\bar{x}_1 = \frac{5}{8}b$   
 $\bar{x}_2 = \frac{1}{4}b$ .

**12.10. SLOPE AND DEFLECTION OF A SIMPLY SUPPORTED BEAM CARRYING A POINT LOAD AT THE CENTRE BY MOHR'S THEOREM**

Fig. 12.19 (a) shows a simply supported  $AB$  of length  $L$  and carrying a point load  $W$  at the centre of the beam *i.e.*, at point  $C$ . The B.M. diagram is shown in Fig. 12.19 (b). This is a case of symmetrical loading, hence slope is zero at the centre *i.e.*, at point  $C$ .

But the deflection is maximum at the centre.

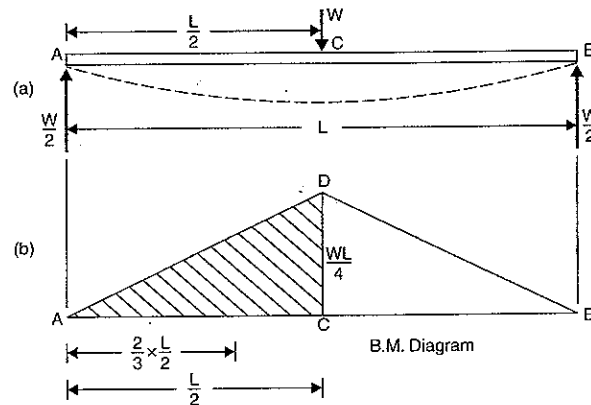

Fig. 12.19

Now using Mohr's theorem for slope, we get

Slope at  $A = \frac{\text{Area of B.M. diagram between A and C}}{EI}$

But area of B.M. diagram between  $A$  and  $C$   
 $=$  Area of triangle  $ACD$   
 $= \frac{1}{2} \times \frac{L}{2} \times \frac{WL}{4} = \frac{WL^2}{16}$

$\therefore$  Slope at  $A$  or  $\theta_A = \frac{WL^2}{EI}$

Now using Mohr's theorem for deflection, we get from equation (12.17) as

$$y = \frac{A\bar{x}}{EI}$$

where  $A$  = Area of B.M. Diagram between  $A$  and  $C$

$$= \frac{WL^2}{16}$$

$\bar{x}$  = Distance of C.G. of area  $A$  from  $A$

$$= \frac{2}{3} \times \frac{L}{2} = \frac{L}{3}$$

$$\therefore y = \frac{\frac{WL^2}{16} \times \frac{L}{3}}{EI} = \frac{WL^3}{48EI}$$

### 12.11. SLOPE AND DEFLECTION OF A SIMPLY SUPPORTED BEAM CARRYING A UNIFORMLY DISTRIBUTED LOAD BY MOHR'S THEOREM

Fig. 12.20 (a) shows a simply supported beam  $AB$  of length  $L$  and carrying a uniformly distributed load of  $w$ /unit length over the entire span. The B.M. diagram is shown in Fig. 12.20 (b). This is a case of symmetrical loading, hence slope is zero at the centre *i.e.*, at point  $C$ .

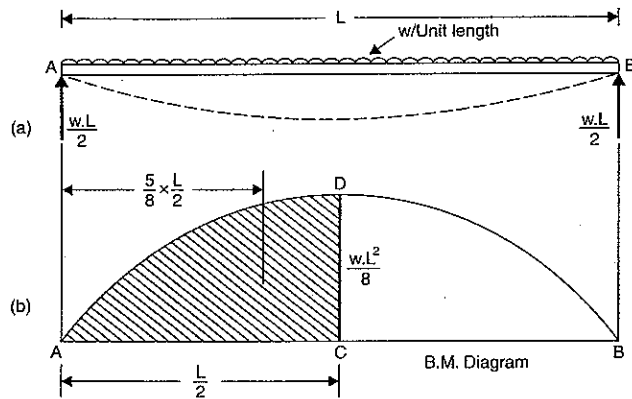

Fig. 12.20

(i) Now using Mohr's theorem for slope, we get

$$\text{Slope at } A = \frac{\text{Area of B.M. diagram between } A \text{ and } C}{EI}$$

$$\begin{aligned} \text{But area of B.M. diagram between } A \text{ and } C &= \text{Area of parabola } ACD \\ &= \frac{2}{3} \times AC \times CD \\ &= \frac{2}{3} \times \frac{L}{2} \times \frac{wL^2}{8} = \frac{w \cdot L^3}{24} \end{aligned}$$

$$\therefore \text{Slope at } A = \frac{w \cdot L^3}{24EI}$$

(ii) Now using Mohr's theorem for deflection, we get from equation (12.17) as

$$y = \frac{A\bar{x}}{EI}$$

where  $A$  = Area of B.M. diagram between  $A$  and  $C$

$$= \frac{w \cdot L^3}{24}$$

and  $\bar{x}$  = Distance of C.G. of area  $A$  from  $A$

$$= \frac{5}{8} \times AC = \frac{5}{8} \times \frac{L}{2} = \frac{5L}{16}$$

$$\therefore y = \frac{\frac{w \cdot L^3}{24} \times \frac{5L}{16}}{EI} = \frac{5}{384} \frac{w \cdot L^4}{EI}$$

### HIGHLIGHTS

1. The relation between curvature, slope, deflection etc. at a section is given by :

$$\text{Deflection} = y$$

$$\text{Slope} = \frac{dy}{dx}$$

$$\text{B.M.} = EI \frac{d^2y}{dx^2}$$

$$\text{S.F.} = EI \frac{d^3y}{dx^3}$$

$$w = EI \frac{d^4y}{dx^4}$$

As deflection is very small, hence slope is also given by  $\frac{dy}{dx} = \tan \theta = \theta$ .

2. Slope at the supports of a simply supported beam carrying a point load at the centre is given by :

$$\theta_A = \theta_B = -\frac{WL^2}{16EI}$$

where  $W$  = Point load at the centre,  $L$  = Length of beam

$E$  = Young's modulus,  $I$  = M.O.I.

3. The deflection at the centre of a simply supported beam carrying a point load at the centre is given by

$$y_C = -\frac{WL^3}{48EI}$$

4. The slope and deflection of a simply supported beam, carrying a uniformly distributed load of  $w$ /unit length over the entire span, are given by,

$$\theta_A = \theta_B = \frac{WL^2}{24EI} \quad \text{and} \quad y_C = \frac{5}{384} \frac{WL^2}{EI}$$

5. Macaulay's method is used in finding slopes and deflections at any point of a beam. In this method :

(i) Brackets are to be integrated as a whole.

(ii) Constants of integrations are written after the first term.

(iii) The section, for which B.M. equation is to be written, should be taken in the last part of the beam.

6. For maximum deflection, the slope  $\frac{dy}{dx}$  is zero.

7. The slope at point  $B$  if slope of  $A$  is zero by moment-area method is given by,

$$\theta_B = \frac{\text{Area of B.M. diagram between } A \text{ and } B}{EI}$$

8. The deflection by moment area method is given by

$$y = \frac{A\bar{x}}{EI}$$

where  $A$  = Area of B.M. diagram between  $A$  and  $B$

$\bar{x}$  = Distance of C.G. of area from  $B$ .

## EXERCISE 12

## (A) Theoretical Questions

1. Derive an expression for the slope and deflection of a beam subjected to uniform bending moment.

2. Prove that the relation that  $M = EI \frac{d^2y}{dx^2}$

where  $M$  = Bending moment,  $E$  = Young's modulus,  $I$  = M.O.I.

3. Find an expression for the slope at the supports of a simply supported beam, carrying a point load at the centre.

4. Prove that the deflection at the centre of a simply supported beam, carrying a point load at the centre, is given by  $y_c = \frac{WL^3}{48EI}$

where  $W$  = Point load,  $L$  = Length of beam.

5. Find an expression for the slope and deflection of a simply supported beam, carrying a point load  $W$  at a distance ' $a$ ' from left support and at a distance ' $b$ ' from right support where  $a > b$ .

6. Prove that the slope and deflection of a simply supported beam of length  $L$  and carrying a uniformly distributed load of  $w$  per unit length over the entire length are given by

$$\text{Slope at supports} = -\frac{WL^2}{24EI}, \text{ and Deflection at centre} = \frac{5}{384} \frac{WL^3}{EI}$$

where  $W$  = Total load =  $w \times L$ .

7. What is a Macaulay's method? Where is it used? Find an expression for deflection at any section of a simply supported beam with an eccentric point load, using Macaulay's method.
8. What is moment-area method? Where is it conveniently used? Find the slope and deflection of a simply supported beam carrying a (i) point load at the centre and (ii) uniformly distributed load over the entire length using moment-area method.

## (B) Numerical Problems

1. A wooden beam 4 m long, simply supported at its ends, is carrying a point load of 7.25 kN at its centre. The cross-section of the beam is 140 mm wide and 240 mm deep. If  $E$  for the beam =  $6 \times 10^3$  N/mm<sup>2</sup>, find the deflection at the centre. [Ans. 10 mm]

2. A beam 5 m long, simply supported at its ends, carries a point load  $W$  at its centre. If the slope at the ends of the beam is not to exceed  $1^\circ$ , find the deflection at the centre of the beam. [Ans. 29.08 mm]

3. Determine: (i) slope at the left support, (ii) deflection under the load and (iii) maximum deflection of a simply supported beam of length 10 m, which is carrying a point load of 10 kN at a distance 6 m from the left end.

Take  $E = 2 \times 10^5$  N/mm<sup>2</sup> and  $I = 1 \times 10^8$  mm<sup>4</sup>. [Ans. 0.00028 rad., 0.96 mm and 0.985 mm]

4. A beam of uniform rectangular section 100 mm wide and 240 mm deep is simply supported at its ends. It carries a uniformly distributed load of 9.125 kN/m run over the entire span of 4 m. Find the deflection at the centre if  $E = 1.1 \times 10^4$  N/mm<sup>2</sup>. [Ans. 6.01 mm]

5. A beam of length 4.8 m and of uniform rectangular section is simply supported at its ends. It carries a uniformly distributed load of 9.375 kN/m run over the entire length. Calculate the width and depth of the beam if permissible bending stress is 7 N/mm<sup>2</sup> and maximum deflection is not to exceed 0.95 cm.

Take  $E$  for beam material =  $1.05 \times 10^4$  N/mm<sup>2</sup>. [Ans.  $b = 240$  mm and  $d = 336.8$  mm]

6. Solve problem 3, using Macaulay's method.

7. A beam of length 10 m is simply supported at its ends and carries two point loads of 100 kN and 60 kN at a distance of 2 m and 5 m respectively from the left support. Calculate the deflections under each load. Find also the maximum deflection.

Take  $I = 18 \times 10^8$  mm<sup>4</sup> and  $E = 2 \times 10^5$  N/mm<sup>2</sup>.

[Ans. (i) - 4.35 mm (ii) - 6.76 mm (iii)  $y_{max} = -6.78$  mm]

8. A beam of length 20 m is simply supported at its ends and carries two point loads of 4 kN and 10 kN at a distance of 8 m and 12 m from left end respectively. Calculate: (i) deflection under each load (ii) maximum deflection.

Take  $E = 2 \times 10^6$  N/mm<sup>2</sup> and  $I = 1 \times 10^9$  mm<sup>4</sup>.

[Ans. (i) 10.3 mm and 10.6 downwards, (ii) 11 mm]

9. A beam of length 6 m is simply supported at its ends. It carries a uniformly distributed load of 10 kN/m as shown in Fig. 12.21. Determine the deflection of the beam at its mid-point and also the position and the maximum deflection.

Take  $EI = 4.5 \times 10^8$  N/mm<sup>2</sup>.

[Ans. - 2.578 mm,  $x = 2.9$  m,  $y_{max} = -2.582$  mm]

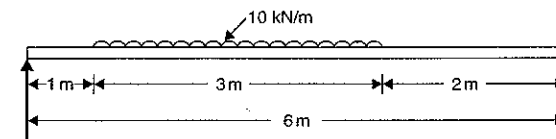

Fig. 12.21

10. A beam  $ABC$  of length 12 metre has one support at the left end and other support at a distance of 8 m from the left end. The beam carries a point load of 12 kN at the right end as shown in Fig. 12.22. Find the slopes over each support and at the right end. Find also the deflection at the right end.

Take  $E = 2 \times 10^5$  N/mm<sup>2</sup> and  $I = 5 \times 10^8$  mm<sup>4</sup>.

[Ans.  $\theta_A = 6.00364$ ,  $\theta_B = -0.00128$ ,  $\theta_C = -0.00224$ ,  $y_C = -7.68$  mm]

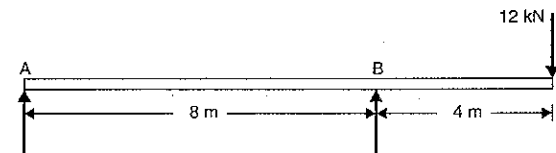

Fig. 12.22

11. An overhanging beam  $ABC$  is loaded as shown in Fig. 12.23. Determine the deflection of the beam at point  $C$ .

Take  $E = 2 \times 10^5$  N/mm<sup>2</sup> and  $I = 5 \times 10^8$  mm<sup>4</sup>.

[Ans.  $y_c = -4.16$  mm]

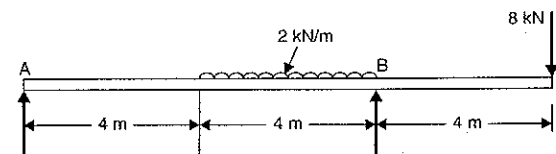

Fig. 12.23

12. A beam of span 8 m and of uniform flexural rigidity  $EI = 40$  MN-m<sup>2</sup>, is simply supported at its ends. It carries a uniformly distributed load of 15 kN/m run over the entire span. It is also subjected to a clockwise moment of 160 kNm at a distance of 3 m from the left support. Calculate the slope of the beam at the point of application of the moment. [Ans. 0.0061 rad.]

## Deflection of Cantilevers

### 13.1. INTRODUCTION

Cantilever is a beam whose one end is fixed and other end is free. In this chapter we shall discuss the methods of finding slope and deflection for the cantilevers when they are subjected to various types of loading. The important methods are (i) Double integration method (ii) Macaulay's method and (iii) Moment-area-method. These methods have also been used for finding deflections and slope of the simply supported beams.

### 13.2. DEFLECTION OF A CANTILEVER WITH A POINT LOAD AT THE FREE END BY DOUBLE INTEGRATION METHOD

A cantilever  $AB$  of length  $L$  fixed at the point  $A$  and free at the point  $B$  and carrying a point load at the free end  $B$  is shown in Fig. 13.1.  $AB$  shows the position of cantilever before any load is applied whereas  $AB'$  shows the position of the cantilever after loading.

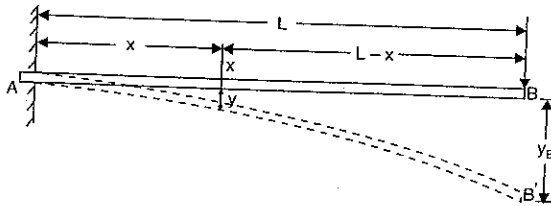

Fig. 13.1

Consider a section  $X$ , at a distance  $x$  from the fixed end  $A$ . The B.M. at this section is given by,

$$M_x = -W(L-x) \quad (\text{Minus sign due to hogging})$$

But B.M. at any section is also given by equation (12.3) as

$$M = EI \frac{d^2y}{dx^2}$$

Equating the two values of B.M., we get

$$EI \frac{d^2y}{dx^2} = -W(L-x) = -WL + Wx$$

Integrating the above equation, we get

$$EI \frac{dy}{dx} = -WLx + \frac{Wx^2}{2} + C_1 \quad \dots(i)$$

Integration again, we get

$$EIy = -WL \frac{x^2}{2} + \frac{W}{2} \frac{x^3}{3} + C_1x + C_2 \quad \dots(ii)$$

where  $C_1$  and  $C_2$  are constant of integrations. Their values are obtained from boundary conditions, which are : (i) at  $x = 0, y = 0$  (ii)  $x = 0, \frac{dy}{dx} = 0$

[At the fixed end, deflection and slopes are zero]

(i) By substituting  $x = 0, y = 0$  in equation (ii), we get

$$0 = 0 + 0 + 0 + C_2 \quad \therefore C_2 = 0$$

(ii) By substituting  $x = 0, \frac{dy}{dx} = 0$  in equation (i), we get

$$0 = 0 + 0 + C_1 \quad \therefore C_1 = 0$$

Substituting the value of  $C_1$  in equation (i), we get

$$\begin{aligned} EI \frac{dy}{dx} &= -WLx + \frac{Wx^2}{2} \\ &= -W \left( Lx - \frac{x^2}{2} \right) \end{aligned} \quad \dots(iii)$$

The equation (iii) is known as *slope equation*. We can find the slope at any point on the cantilever by substituting the value of  $x$ . The slope and deflection are maximum at the free end. These can be determined by substituting  $x = L$  in these equations.

Substituting the values of  $C_1$  and  $C_2$  in equation (ii), we get

$$\begin{aligned} EIy &= -WL \frac{x^2}{2} + \frac{Wx^3}{6} \quad (\because C_1 = 0, C_2 = 0) \\ &= -W \left( \frac{Lx^2}{2} - \frac{x^3}{6} \right) \end{aligned} \quad \dots(iv)$$

The equation (iv) is known as *deflection equation*.

Let  $\theta_B =$  slope at the free end  $B$  i.e.,  $\left( \frac{dy}{dx} \right)$  at  $B = \theta_B$  and

$y_B =$  Deflection at the free end  $B$

(a) Substituting  $\theta_B$  for  $\frac{dy}{dx}$  and  $x = L$  in equation (iii), we get

$$EI\theta_B = -W \left( L \cdot L - \frac{L^2}{2} \right) = -W \cdot \frac{L^2}{2}$$

$$\therefore \theta_B = -\frac{WL^2}{2EI} \quad \dots(13.1)$$

Negative sign shows that tangent at  $B$  makes an angle in the anti-clockwise direction with  $AB$

$$\therefore \theta_B = \frac{WL^2}{2EI} \quad \dots(13.1A)$$

(b) Substituting  $y_B$  for  $y$  and  $x = L$  in equation (iv), we get

$$EI y_B = -W \left( L \cdot \frac{L^2}{2} - \frac{L^3}{6} \right) = -W \left( \frac{L^3}{2} - \frac{L^3}{6} \right) = -W \cdot \frac{L^3}{3}$$

$$\therefore y_B = -\frac{WL^3}{3EI} \quad \dots(13.2)$$

(Negative sign shows that deflection is downwards)

$$\therefore \text{Downward deflection, } y_B = \frac{WL^3}{3EI} \quad \dots(13.2 A)$$

### 13.3. DEFLECTION OF A CANTILEVER WITH A POINT LOAD AT A DISTANCE 'a' FROM THE FIXED END

A cantilever AB of length  $L$  fixed at point A and free at point B and carrying a point load  $W$  at a distance 'a' from the fixed end A, is shown in Fig. 13.2.

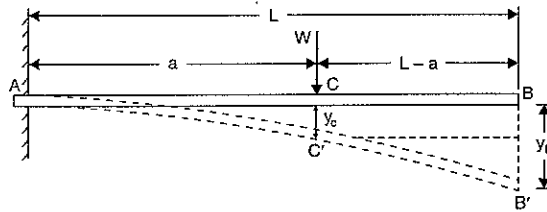

Fig. 13.2

Let  $\theta_C =$  Slope at point C i.e.,  $\left(\frac{dy}{dx}\right)$  at C

$y_C =$  Deflection at point C

$y_B =$  Deflection at point B

The portion AC of the cantilever may be taken as similar to a cantilever in Art. 13.1 (i.e., load at the free end).

$$\therefore \theta_C = +\frac{Wa^2}{2EI} \quad [\text{In equation (13.1 A) change } L \text{ to } a]$$

and  $y_C = \frac{Wa^3}{3EI} \quad [\text{In equation (13.2 A) change } L \text{ to } a]$

The beam will bend only between A and C, but from C to B it will remain straight since B.M. between C and B is zero.

Since the portion CB of the cantilever is straight, therefore

Slope at C = slope at B

or  $\theta_C = \theta_B = \frac{Wa^2}{2EI} \quad \dots(13.3)$

Now from Fig. 13.2, we have

$$y_B = y_C + \theta_C(L-a) = \frac{Wa^3}{3EI} + \frac{Wa^2}{2EI}(L-a) \quad \left( \because \theta_C = \frac{Wa^2}{2EI} \right) \quad \dots(13.4)$$

**Problem 13.1.** A cantilever of length 3 m is carrying a point load of 25 kN at the free end. If the moment of inertia of the beam =  $10^8 \text{ mm}^4$  and value of  $E = 2.1 \times 10^5 \text{ N/mm}^2$ , find (i) slope of the cantilever at the free end and (ii) deflection at the free end.

**Sol.** Given :

Length,  $L = 3 \text{ m} = 3000 \text{ mm}$

Point load,  $W = 25 \text{ kN} = 25000 \text{ N}$

M.O.I.,  $I = 10^8 \text{ mm}^4$

Value of  $E = 2.1 \times 10^5 \text{ N/mm}^2$

(i) Slope at the free end is given by equation (13.1 A).

$$\therefore \theta_B = \frac{WL^2}{2EI} = \frac{25000 \times 3000^2}{2 \times 2.1 \times 10^5 \times 10^8} = 0.005357 \text{ rad. Ans.}$$

(ii) Deflection at the free end is given by equation (13.2 A),

$$y_B = \frac{WL^3}{3EI} = \frac{25000 \times 3000^3}{3 \times 2.1 \times 10^5 \times 10^8} = 10.71 \text{ mm. Ans.}$$

**Problem 13.2.** A cantilever of length 3 m is carrying a point load of 50 kN at a distance of 2 m from the fixed end. If  $I = 10^8 \text{ mm}^4$  and  $E = 2 \times 10^5 \text{ N/mm}^2$ , find (i) slope at the free end and (ii) deflection at the free end.

**Sol.** Given :

Length,  $L = 3 \text{ m} = 3000 \text{ mm}$

Point load,  $W = 50 \text{ kN} = 50000 \text{ N}$

Distance between the load and the fixed end,

$a = 2 \text{ m} = 2000 \text{ mm}$

M.O.I.,  $I = 10^8 \text{ mm}^4$

Value of  $E = 2 \times 10^5 \text{ N/mm}^2$

(i) Slope at the free end is given by equation (13.3) as

$$\theta_B = \frac{Wa^2}{2EI} = \frac{50000 \times 2000^2}{2 \times 2 \times 10^5 \times 10^8} = 0.005 \text{ rad. Ans.}$$

(ii) Deflection at the free end is given by equation (13.4) as

$$y_B = \frac{Wa^3}{3EI} + \frac{Wa^2}{2EI}(L-a) = \frac{50000 \times 2000^3}{3 \times 2 \times 10^5 \times 10^8} + \frac{50000 \times 2000^2}{2 \times 2 \times 10^5 \times 10^8} (3000 - 2000) = 6.67 + 5.0 = 11.67 \text{ mm. Ans.}$$

### 13.4. DEFLECTION OF A CANTILEVER WITH A UNIFORMLY DISTRIBUTED LOAD

A cantilever AB of length  $L$  fixed at the point A and free at the point B and carrying a uniformly distributed load of  $w$  per unit length over the whole length, is shown in Fig. 13.3.

Consider a section X, at a distance  $x$  from the fixed end A. The B.M. at this section is given by,

$$M_x = -w(L-x) \cdot \frac{(L-x)}{2} \quad (\text{Minus sign due to hogging})$$

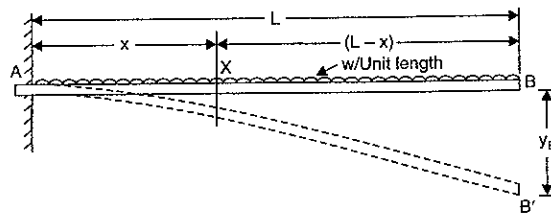

Fig. 13.3

But B.M. at any section is also given by equation (12.3) as

$$M = EI \frac{d^2 y}{dx^2}$$

Equating the two values of B.M., we get

$$EI \frac{d^2 y}{dx^2} = -\frac{w}{2} (L-x)^2$$

Integrating the above equation, we get

$$\begin{aligned} EI \frac{dy}{dx} &= -\frac{w}{2} \frac{(L-x)^3}{3} (-1) + C_1 \\ &= \frac{w}{6} (L-x)^3 + C_1 \end{aligned} \quad \dots(i)$$

Integrating again, we get

$$\begin{aligned} EIy &= \frac{w}{6} \cdot \frac{(L-x)^4}{4} (-1) + C_1 x + C_2 \\ &= -\frac{w}{24} (L-x)^4 + C_1 x + C_2 \end{aligned} \quad \dots(ii)$$

where  $C_1$  and  $C_2$  are constant of integrations. Their values are obtained from boundary conditions, which are : (i) at  $x = 0, y = 0$  and (ii) at  $x = 0, \frac{dy}{dx} = 0$  (as the deflection and slope at fixed end A are zero).

(i) By substituting  $x = 0, y = 0$  in equation (ii), we get

$$0 = -\frac{w}{24} (L-0)^4 + C_1 \times 0 + C_2 = -\frac{wL^4}{24} + C_2$$

$$\therefore C_2 = \frac{wL^4}{24}$$

(ii) By substituting  $x = 0$  and  $\frac{dy}{dx} = 0$  in equation (i), we get

$$0 = \frac{w}{6} (L-0)^3 + C_1 = \frac{wL^3}{6} + C_1$$

$$\therefore C_1 = -\frac{wL^3}{6}$$

Substituting the values of  $C_1$  and  $C_2$  in equation (i) and (ii), we get

$$EI \frac{dy}{dx} = \frac{w}{6} (L-x)^3 - \frac{wL^3}{6} \quad \dots(iii)$$

and

$$EIy = -\frac{w}{24} (L-x)^4 - \frac{wL^3}{6} x + \frac{wL^4}{24} \quad \dots(iv)$$

The equation (iii) is known as *slope equation* and equation (iv) as *deflection equation*. From these equations the slope and deflection can be obtained at any sections. To find the slope and deflection at point B, the value of  $x = L$  is substituted in these equations.

Let  $\theta_B =$  Slope at the free end B i.e.,  $\left(\frac{dy}{dx}\right)$  at B

$y_B =$  Deflection at the free end B.

From equation (iii), we get slope at B as

$$EI \theta_B = \frac{w}{6} (L-L)^3 - \frac{wL^3}{6} = -\frac{wL^3}{6}$$

$$\therefore \theta_B = -\frac{wL^3}{6EI} = -\frac{WL^2}{6EI} \quad (\because W = \text{Total load} = wL) \quad \dots(13.5)$$

From equation (iv), we get the deflection at B as

$$\begin{aligned} EI y_B &= -\frac{w}{24} (L-L)^4 - \frac{wL^3}{6} \times L + \frac{wL^4}{24} \\ &= -\frac{wL^4}{6} + \frac{wL^4}{24} = -\frac{3}{24} wL^4 = -\frac{wL^4}{8} \end{aligned}$$

$$\therefore y_B = -\frac{wL^4}{8EI} = -\frac{WL^3}{8EI} \quad (\because W = wL)$$

$\therefore$  Downward deflection at B,

$$y_B = \frac{wL^4}{8EI} = \frac{WL^3}{8EI} \quad \dots(13.6)$$

**Problem 13.3.** A cantilever of length 2.5 m carries a uniformly distributed load of 16.4 kN per metre length over the entire length. If the moment of inertia of the beam =  $7.95 \times 10^7 \text{ mm}^4$  and value of  $E = 2 \times 10^5 \text{ N/mm}^2$ , determine the deflection at the free end.

**Sol.** Given :

Length,  $L = 2.5 \text{ m} = 2500 \text{ mm}$

U.d.l.,  $w = 16.4 \text{ kN/m}$

$\therefore$  Total load,  $W = w \times L = 16.4 \times 2.5 = 41 \text{ kN} = 41000 \text{ N}$

Value of  $I = 7.95 \times 10^7 \text{ mm}^4$

Value of  $E = 2 \times 10^5 \text{ N/mm}^2$

Let  $y_B =$  Deflection at the free end,

Using equation (13.6), we get

$$\begin{aligned} y_B &= \frac{WL^3}{8EI} = \frac{41000 \times 2500^3}{8 \times 2 \times 10^5 \times 7.95 \times 10^7} \\ &= 5.036 \text{ mm. Ans.} \end{aligned}$$

**Problem 13.4.** A cantilever of length 3 m carries a uniformly distributed load over the entire length. If the deflection at the free end is 40 mm, find the slope at the free end.

Sol. Given :

Length,  $L = 3 \text{ m} = 3000 \text{ m}$

Deflection at free end,  $y_B = 40 \text{ mm}$

Let  $\theta_B = \text{slope at the free end}$

Using equation (13.6), we get

$$y_B = \frac{WL^3}{8EI}$$

$$40 = \frac{WL^2 \times L}{8EI} = \frac{WL^2 \times 3000}{8EI}$$

$$\frac{WL^2}{EI} = \frac{40 \times 8}{3000} \quad \dots(i)$$

Slope at the free end is given by equation (13.5),

$$\theta_B = -\frac{WL^2}{6EI} = -\frac{WL^2}{EI} \times \frac{1}{6} = -\frac{40 \times 8}{3000} \times \frac{1}{6}$$

$$\left[ \because \text{From equation (i), } \frac{WL^2}{EI} = \frac{40 \times 8}{3000} \right]$$

$$= 0.01777 \text{ rad. Ans.}$$

**Problem 13.4 (A).** A cantilever 120 mm wide and 200 mm deep is 2.5 m long. What is the uniformly distributed load which the beam can carry in order to produce a deflection of 5 mm at the free end? Take  $E = 200 \text{ GN/m}^2$ . (Annamalai University, 1991)

Sol. Given :

Width,  $b = 120 \text{ mm}$

Depth,  $d = 200 \text{ mm}$

Length,  $L = 2.5 \text{ m} = 2.5 \times 1000 = 2500 \text{ mm}$

Deflection at free end,  $y_B = 5 \text{ mm}$

Value of  $E = 200 \text{ GN/m}^2 = 200 \times 10^9 \text{ N/m}^2$  ( $\because G = \text{Giga} = 10^9$ )

$$= \frac{200 \times 10^9 \text{ N}}{(1000)^2 \text{ mm}^2} \quad [\because 1 \text{ m}^2 = (1000 \text{ mm})^2]$$

$$= 2 \times 10^5 \text{ N/mm}^2$$

$$\text{Moment of inertia, } I = \frac{bd^3}{12} = \frac{120 \times 200^3}{12} = 8 \times 10^7 \text{ mm}^4$$

Let  $w = \text{uniformly distributed load per m length in N}$

$W = \text{Total load}$

$$= w \times L$$

$$= w \times 2.5 = 2.5 \times w \text{ N}$$

(Here  $L$  is in metre)

Using equation (13.6), we get

$$y_B = \frac{WL^3}{8EI}$$

$$5 = \frac{2.5w \times 2500^3}{8 \times 2 \times 10^5 \times 8 \times 10^7}$$

$$\text{or } w = \frac{5 \times 8 \times 2 \times 10^5 \times 8 \times 10^7}{2.5 \times 2500^3} = 16384 \text{ N/m}$$

$$= 16.384 \text{ kN/m. Ans.}$$

### 13.5. DEFLECTION OF A CANTILEVER WITH A UNIFORMLY DISTRIBUTED LOAD FOR A DISTANCE 'a' FROM THE FIXED END

A cantilever  $AB$  of length  $L$  fixed at the point  $A$  and free at the point  $B$  and carrying a uniformly distributed load of  $w/m$  length for a distance 'a' from the fixed end, is shown in Fig. 13.4.

The beam will bend only between  $A$  and  $C$ , but from  $C$  to  $B$  it will remain straight since B.M. between  $C$  and  $B$  is zero. The deflected shape of the cantilever is shown by  $AC'B'$  in which portion  $C'B'$  is straight.

Let  $\theta_C = \text{Slope at } C, \text{ i.e., } \left(\frac{dy}{dx}\right) \text{ at } C$

$y_C = \text{Deflection at point } C, \text{ and}$

$y_B = \text{Deflection at point } B.$

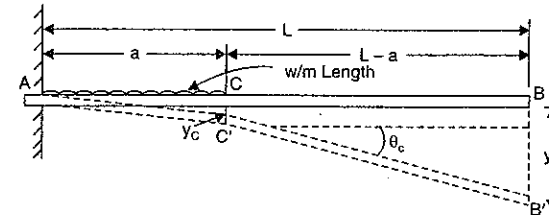

Fig. 13.4

The portion  $AC$  of the cantilever may be taken as similar to a cantilever in Art. 13.4.

$$\therefore \theta_C = \frac{w \cdot a^3}{6EI} \quad [\text{In equation (13.5) put } L = a]$$

$$\text{and } y_C = \frac{w \cdot a^4}{8EI} \quad [\text{In equation (13.6) put } L = a]$$

Since the portion  $C'B'$  of the cantilever is straight, therefore slope at  $C = \text{slope at } B$

$$\text{or } \theta_C = \theta_B = \frac{wa^3}{6EI} \quad \dots(13.7)$$

Now from Fig. 13.4, we have

$$y_B = y_C + \theta_C(L-a)$$

$$= \frac{wa^4}{8EI} + \frac{w \cdot a^3}{6EI}(L-a) \quad \dots(13.8)$$

### 13.6. DEFLECTION OF A CANTILEVER WITH A UNIFORMLY DISTRIBUTED LOAD FOR A DISTANCE 'a' FROM THE FREE END

A cantilever  $AB$  of length  $L$  fixed at the point  $A$  and free at the point  $B$  and carrying a uniformly distributed load of  $w/m$  length for a distance 'a' from the free end is shown in Fig. 13.5 (a).



The slope and deflection at the point  $B$  is determined by considering :

- (i) the whole cantilever  $AB$  loaded with a uniformly distributed load of  $w$  per unit length as shown in Fig. 13.5 (b).  
 (ii) a part of cantilever from  $A$  to  $C$  of length  $(L - a)$  loaded with an upward uniformly distributed load of  $w$  per unit length as shown in Fig. 13.5 (c).

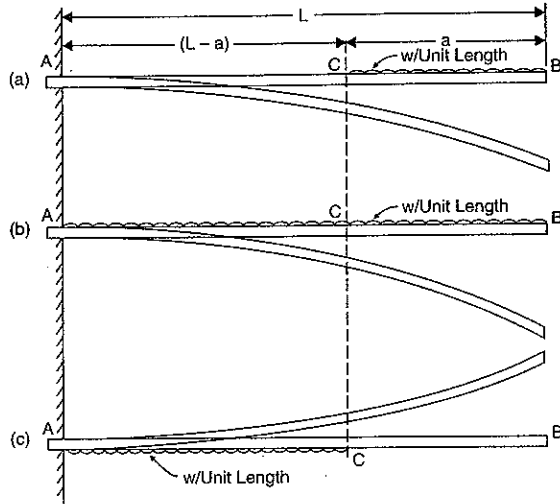

Fig. 13.5

Then slope at  $B$  = Slope due to downward uniform load over the whole length  
 – slope due to upward uniform load from  $A$  to  $C$

and deflection at  $B$  = Deflection due to downward uniform load over the whole length  
 – deflection due to upward uniform load from  $A$  to  $C$ .

(a) Now slope at  $B$  due to downward uniformly distributed load over the whole length

$$= \frac{wL^3}{6EI}$$

(b) Slope at  $B$  or at  $C$  due to upward uniformly distributed load over the length  $(L - a)$

$$= \frac{w(L - a)^3}{6EI}$$

Hence net slope at  $B$  is given by,

$$\theta_B = \frac{wL^3}{6EI} - \frac{w(L - a)^3}{6EI} \quad \dots(13.9)$$

The downward deflection of point  $B$  due to downward distributed load over the whole length  $AB$

$$= \frac{wL^4}{8EI}$$

The upward deflection of point  $B$  due to upward uniformly distributed load acting on the portion  $AC$  = upward deflection of  $C$  + slope at  $C$   $\times CB$

$$= \frac{w(L - a)^4}{8EI} + \frac{w \cdot (L - a)^3}{6EI} \times a \quad (\because CB = a)$$

$\therefore$  Net downward deflection of the free end  $B$  is given by

$$y_B = \frac{wL^4}{8EI} - \left[ \frac{w(L - a)^4}{8EI} + \frac{w(L - a)^3}{6EI} \times a \right] \quad \dots(13.10)$$

**Problem 13.5.** Determine the slope and deflection of the free end of a cantilever of length 3 m which is carrying a uniformly distributed load of 10 kN/m over a length of 2 m from the fixed end.

Take  $I = 10^8 \text{ mm}^4$  and  $E = 2 \times 10^5 \text{ N/mm}^2$ .

**Sol.** Given :

Length,  $L = 3 \text{ m} = 3000 \text{ mm}$

U.d.l.,  $w = 10 \text{ kN/m} = 10000 \text{ N/m} = \frac{10000}{1000} \text{ N/mm} = 10 \text{ N/mm}$

Length of u.d.l. from fixed end,  $a = 2 \text{ m} = 2000 \text{ mm}$ .

Value of  $I = 10^8 \text{ mm}^4$

Value of  $E = 2 \times 10^5 \text{ N/mm}^2$

Let  $\theta_B$  = Slope of the free end and

$y_B$  = Deflection at the free end.

(i) Using equation (13.7), we have

$$\theta_B = \frac{w a^3}{6EI} = \frac{10 \times 2000^3}{6 \times 2 \times 10^5 \times 10^8} = 0.00066. \text{ Ans.}$$

(ii) Using equation (13.8), we get

$$\begin{aligned} y_B &= \frac{w a^4}{8EI} + \frac{w \cdot a^3}{6EI} (L - a) \\ &= \frac{10 \times 2000^4}{8 \times 2 \times 10^5 \times 10^8} + \frac{10 \times 2000^3}{6 \times 2 \times 10^5 \times 10^8} \times (3000 - 2000) \\ &= 1 + 0.67 = 1.67 \text{ mm. Ans.} \end{aligned}$$

**Problem 13.6.** A cantilever of length 3 m carries a uniformly distributed load of 10 kN/m over a length of 2 m from the free end. If  $I = 10^8 \text{ mm}^4$  and  $E = 2 \times 10^5 \text{ N/mm}^2$ ; find : (i) slope at the free end, and (ii) deflection at the free end.

**Sol.** Given :

Length,  $L = 3 \text{ m} = 3000 \text{ mm}$

U.d.l.,  $w = 10 \text{ kN/m} = 10000 \text{ N/m} = \frac{10000}{1000} \text{ N/mm} = 10 \text{ N/mm}$

Length of u.d.l. from free end,  $a = 2 \text{ m} = 2000 \text{ mm}$

Value of  $I = 10^8 \text{ mm}^4$

Value of  $E = 2 \times 10^5 \text{ N/mm}^2$

Let  $\theta_B =$  Slope at the free end i.e.,  $\left(\frac{dy}{dx}\right)$  at B and

$y_B =$  Deflection at the free end.

(i) Using equation (13.9), we get

$$\begin{aligned}\theta_B &= \frac{wL^3}{6EI} - \frac{w(L-a)^3}{6EI} \\ &= \frac{10 \times 3000^3}{6 \times 2 \times 10^5 \times 10^8} - \frac{10(3000-2000)^3}{6 \times 2 \times 10^5 \times 10^8} \\ &= 0.00225 - 0.000083 = \mathbf{0.002167 \text{ rad.}} \quad \text{Ans.}\end{aligned}$$

(ii) Using equation (13.10), we get

$$\begin{aligned}y_B &= \frac{wL^4}{8EI} - \left[ \frac{w(L-a)^4}{8EI} + \frac{w(L-a)^3}{6EI} \times a \right] \\ &= \frac{10 \times 3000^4}{8 \times 2 \times 10^5 \times 10^8} - \left[ \frac{10(3000-2000)^4}{8 \times 2 \times 10^5 \times 10^8} + \frac{10(3000-2000)^3}{6 \times 2 \times 10^5 \times 10^8} \times 2000 \right] \\ &= 5.0625 - [0.0625 + 0.1667] = \mathbf{4.8333 \text{ mm.}} \quad \text{Ans.}\end{aligned}$$

**Problem 13.7.** A cantilever of length 3 m carries two point loads of 2 kN at the free end and 4 kN at a distance of 1 m from the free end. Find the deflection at the free end.

Take  $E = 2 \times 10^5 \text{ N/mm}^2$  and  $I = 10^8 \text{ mm}^4$ .

Sol. Given :

Length,  $L = 3 \text{ m} = 3000 \text{ mm}$

Load at free end,  $W_1 = 2 \text{ kN} = 2000 \text{ N}$

Load at a distance one m from free end,

$W_2 = 4 \text{ kN} = 4000 \text{ N}$

Distance AC,  $a = 2 \text{ m} = 2000 \text{ mm}$

Value of  $E = 2 \times 10^5 \text{ N/mm}^2$

Value of  $I = 10^8 \text{ mm}^4$

Let  $y_1 =$  Deflection at the free end due to load 2 kN alone

$y_2 =$  Deflection at the free end due to load 4 kN alone.

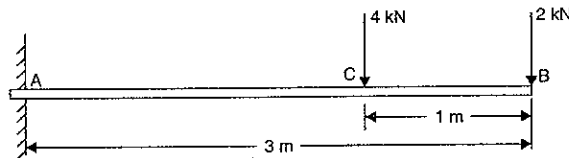

Fig. 13.6

Downward deflection due to load 2 kN alone at the free end is given by equation (13.2 A)

as

$$y_1 = \frac{WL^3}{3EI} = \frac{2000 \times 3000^3}{3 \times 2 \times 10^5 \times 10^8} = 0.9 \text{ mm.}$$

Downward deflection at the free end due to load 4 kN (i.e., 4000 N) alone at a distance 2 m from fixed end is given by (13.4) as

$$\begin{aligned}y_2 &= \frac{Wa^3}{3EI} + \frac{Wa^2}{2EI} (L-a) \\ &= \frac{4000 \times 2000^3}{3 \times 2 \times 10^5 \times 10^8} + \frac{4000 \times 2000^2}{2 \times 2 \times 10^5 \times 10^8} (3000 - 2000) \\ &= 0.54 + 0.40 = 0.94 \text{ mm}\end{aligned}$$

$\therefore$  Total deflection at the free end

$$\begin{aligned}&= y_1 + y_2 \\ &= 0.9 + 0.94 = \mathbf{1.84 \text{ mm.}} \quad \text{Ans.}\end{aligned}$$

**Problem 13.8.** A cantilever of length 2 m carries a uniformly distributed load of 2.5 kN/m run for a length of 1.25 m from the fixed end and a point load of 1 kN at the free end. Find the deflection at the free end if the section is rectangular 12 cm wide and 24 cm deep and  $E = 1 \times 10^4 \text{ N/mm}^2$ . (Annamalai University, 1990)

Sol. Given :

Length,  $L = 2 \text{ m} = 2000 \text{ mm}$

U.d.l.,  $w = 2.5 \text{ kN/m} = 2.5 \times 1000 \text{ N/m}$

$$= \frac{2.5 \times 1000}{1000} \text{ N/mm} = 2.5 \text{ N/mm}$$

Point load at free end,  $W = 1 \text{ kN} = 1000 \text{ N}$

Distance AC,  $a = 1.25 \text{ m} = 1250 \text{ mm}$

Width,  $b = 12 \text{ mm}$

Depth,  $d = 24 \text{ mm}$

Value of  $I = \frac{bd^3}{12} = \frac{12 \times 24^3}{12}$

$$= 13824 \text{ cm}^4 = 13824 \times 10^4 \text{ mm}^4 = 1.3824 \times 10^4 \text{ mm}^4$$

Value of  $E = 1 \times 10^4 \text{ N/mm}^2$

Let

$y_1 =$  Deflection at the free end due to point load 1 kN alone

$y_2 =$  Deflection at the free end due to u.d.l. on length AC.

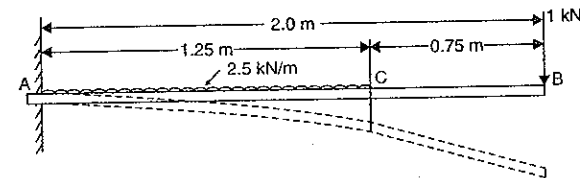

Fig. 13.7

(i) Now the downward deflection at the free end due to point load of 1 kN (or 1000 N) at the free end is given by equation (13.2 A) as

$$y_1 = \frac{WL^3}{3EI} = \frac{1000 \times 2000^3}{3 \times 10^4 \times 1.3824 \times 10^8} = 1.929 \text{ mm.}$$

(ii) The downward deflection at the free end due to uniformly distributed load of 2.5 N/mm on a length of 1.25 m (or 1250 mm) is given by equation (13.8) as

$$y_2 = \frac{wa^4}{8EI} + \frac{w \cdot a^3}{6EI} (L-a)$$

$$= \frac{2.5 \times 1250^4}{8 \times 10^4 \times 1.3824 \times 10^8} + \frac{2.5 \times 1250^3}{6 \times 10^4 \times 1.3824 \times 10^8} (2000 - 1250)$$

$$= 0.5519 + 0.4415 = 0.9934$$

∴ Total deflection at the free end due to point load and u.d.l.

$$= y_1 + y_2 = 1.929 + 0.9934 = \mathbf{2.9224 \text{ mm. Ans.}}$$

**Problem 13.9.** A cantilever of length 2 m carries a uniformly distributed load 2 kN/m over a length of 1 m from the free end, and a point load of 1 kN at the free end. Find the slope and deflection at the free end if  $E = 2.1 \times 10^5 \text{ N/mm}^2$  and  $I = 6.667 \times 10^7 \text{ mm}^4$ .

**Sol.** Given : (See Fig. 13.8)

Length,  $L = 2 \text{ m} = 2000 \text{ mm}$

U.d.l.  $w = 2 \text{ kN/m} = \frac{2 \times 1000}{1000} \text{ N/mm} = 2 \text{ N/mm}$

Length BC,  $a = 1 \text{ m} = 1000 \text{ mm}$

Point load,  $W = 1 \text{ kN} = 1000 \text{ N}$

Value of  $E = 2.1 \times 10^5 \text{ N/mm}^2$

Value of  $I = 6.667 \times 10^7 \text{ mm}^4$ .

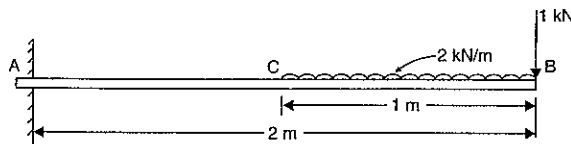

Fig. 13.8

(i) Slope at the free end

Let  $\theta_1 =$  Slope at the free end due to point load of 1 kN i.e., 1000 N

$\theta_2 =$  Slope at the free end due to u.d.l. on length BC.

The slope at the free end due to a point load of 1000 N at B is given by equation (13.1 A)

as

$$\theta_1 = \frac{WL^2}{2EI} \quad (\because \theta_B = \theta_1 \text{ here})$$

$$= \frac{1000 \times 2000^2}{2 \times 2.1 \times 10^5 \times 6.667 \times 10^7} = 0.0001428 \text{ rad.}$$

The slope at the free end due to u.d.l. of 2 kN/m over a length of 1 m from the free end is given by equation (13.9) as

$$\theta_2 = \frac{wL^3}{6EI} - \frac{w(L-a)^3}{6EI} \quad (\because \theta_B = \theta_2 \text{ here})$$

$$= \frac{2 \times 2000^3}{6 \times 2.1 \times 10^5 \times 6.667 \times 10^7} - \frac{2 \times (2000 - 1000)^3}{6 \times 2.1 \times 10^5 \times 6.667 \times 10^7}$$

$$= 0.0001904 - 0.000238 = 0.0001666 \text{ rad.}$$

∴ Total slope at the free end

$$= \theta_1 + \theta_2 = 0.0001428 + 0.0001666 = \mathbf{0.0003094 \text{ rad. Ans.}}$$

(ii) Deflection at the free end

Let  $y_1 =$  Deflection at the free end due to point load of 1000 N

$y_2 =$  Deflection at the free end due to u.d.l. on length BC.

The deflection at the free end due to point load of 1000 N is given by equation (13.2 A) as

$$y_1 = \frac{WL^3}{3EI} \quad (\because \text{Here } y_1 = y_B)$$

$$= \frac{1000 \times 2000^3}{3 \times 2.1 \times 10^5 \times 6.667 \times 10^7} = 0.1904 \text{ mm.}$$

The deflection at the free end due to u.d.l. of 2 N/mm over a length of 1 m from the free end is given by equation (13.10) as

$$y_2 = \frac{wL^4}{8EI} - \left[ \frac{w(L-a)^4}{8EI} + \frac{w(L-a)^3}{6EI} \times a \right]$$

$$= \frac{2 \times 2000^4}{8 \times 2.1 \times 10^5 \times 6.667 \times 10^7} - \left[ \frac{2(2000 - 1000)^4}{8 \times 2.1 \times 10^5 \times 6.667 \times 10^7} + \frac{2(2000 - 1000)^3 \times 1000}{6 \times 2.1 \times 10^5 \times 6.667 \times 10^7} \right]$$

$$= 0.2857 - [0.01785 + 0.0238] = 0.244 \text{ mm}$$

∴ Total deflection at the free end

$$= y_1 + y_2 = 0.1904 + 0.244 = \mathbf{0.4344 \text{ mm. Ans.}}$$

### 13.7. DEFLECTION OF A CANTILEVER WITH A GRADUALLY VARYING LOAD

A cantilever AB of length  $L$  fixed at the point A and free at the point B and carrying a gradually varying load from 0 at B to  $w$  per unit run at the fixed end A, is shown in Fig. 13.9.

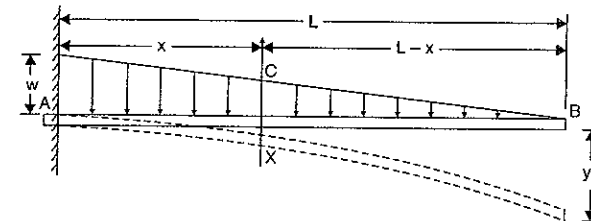

Fig. 13.9

Consider a section X at a distance  $x$  from the fixed end A.

The load at X will be  $\frac{w}{L}(L-x)$  per unit run. Hence vertical height  $XC = \frac{w}{L}(L-x)$ .

Hence the B.M. at this section is given by

$$M_x = -(\text{Load on length } Bx) \times (\text{Distance of C.G. of the load on } Bx \text{ from section } X)$$

$$= -(\text{Area of } \triangle BXC) \times (\text{Distance of C.G. of area } BXC \text{ from } X)$$

(Minus sign is due to hogging)

$$= - \left( \frac{BX \cdot XC}{2} \right) \times \left( \frac{1}{3} \text{ of length } BX \right)$$

$$= - \frac{(L-x)}{2} \cdot \frac{w}{L} (L-x) \times \left[ \frac{1}{3} (L-x) \right] = - \frac{w}{6L} (L-x)^3.$$

But B.M. at any section is also given by equation (12.3) as

$$M = EI \frac{d^2 y}{dx^2}$$

Equating the two values of B.M., we get

$$EI \frac{d^2 y}{dx^2} = - \frac{w}{6L} (L-x)^3$$

Integrating the above equation, we get

$$EI \frac{dy}{dx} = - \frac{w}{6L} \frac{(L-x)^4}{4} (-1) + C_1$$

$$= - \frac{w}{24L} (L-x)^4 + C_1 \quad \dots(i)$$

Integrating again, we get

$$EIy = - \frac{w}{24L} \frac{(L-x)^5}{5} (-1) + C_1 x + C_2$$

$$= - \frac{w}{120L} (L-x)^5 + C_1 x + C_2 \quad \dots(ii)$$

where  $C_1$  and  $C_2$  are constant of integrations. Their values are obtained from boundary conditions, which are :

(i) at  $x = 0, y = 0$  and (ii) at  $x = 0, \frac{dy}{dx} = 0$ .

(i) By substituting  $x = 0$  and  $y = 0$  in equation (ii), we get

$$0 = - \frac{w}{120L} (L-0)^5 + C_1 \times 0 + C_2 \quad \text{or} \quad C_2 = \frac{wL^4}{120}$$

(ii) By substituting  $x = 0$  and  $\frac{dy}{dx} = 0$  in equation (i), we get

$$0 = - \frac{w}{24L} (L-0)^4 + C_1$$

$$\therefore C_1 = - \frac{wL^4}{24L} = - \frac{wL^3}{24}$$

Substituting the values of  $C_1$  and  $C_2$  in equations (i) and (ii), we get

$$EI \frac{dy}{dx} = \frac{w}{24L} (L-x)^4 - \frac{wL^3}{24} \quad \dots(iii)$$

and

$$EIy = - \frac{w}{120L} (L-x)^5 - \frac{wL^3}{24} x + \frac{wL^4}{120} \quad \dots(iv)$$

The equation (iii) is known as *slope equation* and equation (iv) as *deflection equation*. The slope and deflection at the free end (i.e., point B) can be obtained by substituting  $x = L$  in these equations.

Let  $\theta_B =$  Slope at the free end B i.e.,  $\left( \frac{dy}{dx} \right)$  at B and

$y_B =$  Deflection at the free end B.

(a) Substituting  $x = L$  and  $\frac{dy}{dx} = \theta_B$  in equation (iii), we get

$$EI \theta_B = \frac{w}{24L} (L-L)^4 - \frac{wL^3}{24} = - \frac{wL^3}{24}$$

$$\therefore \theta_B = - \frac{wL^3}{24EI} \text{ radians.} \quad \dots(13.11)$$

(b) Substituting  $x = L$  and  $y = y_B$  in equation (iv), we get

$$EI y_B = - \frac{w}{120L} (L-L)^5 - \frac{wL^3}{24} \cdot L + \frac{wL^4}{120}$$

$$= 0 - \frac{wL^4}{24} + \frac{wL^4}{120} = - \frac{5wL^4 + wL^4}{120} = - \frac{wL^4}{30}$$

$$\therefore y_B = - \frac{wL^4}{30EI} \quad (\text{Minus sign means downward deflection})$$

$\therefore$  Downward deflection of B is given by

$$y_B = \frac{wL^4}{30EI} \quad \dots(13.12)$$

**Problem 13.10.** A cantilever of length 4 m carries a uniformly varying load of zero intensity at the free end, and 50 kN/m at the fixed end.

If  $E = 2.0 \times 10^5 \text{ N/mm}^2$  and  $I = 10^8 \text{ mm}^4$ , find the slope and deflection at the free end.

**Sol.** Given :

Length,  $L = 4 \text{ m} = 4000 \text{ mm}$

Load at fixed end,  $w = 50 \text{ kN/m} = \frac{50 \times 1000}{1000} = 50 \text{ N/mm}$

Value of  $E = 2 \times 10^5 \text{ N/mm}^2$

Value of  $I = 10^8 \text{ mm}^4$

Let  $\theta_B =$  Slope at the free end and

$y_B =$  Deflection at the free end.

(i) Using equation (13.11), we get

$$\theta_B = - \frac{wL^3}{24EI} = - \frac{50 \times (4000)^3}{24 \times 2 \times 10^5 \times 10^8} = \mathbf{0.00667 \text{ rad. Ans.}}$$

(ii) Using equation (13.12), we get

$$y_B = \frac{wL^4}{30EI} = \frac{50 \times (4000)^4}{30 \times 2 \times 10^5 \times 10^8} = \mathbf{21.33 \text{ mm. Ans.}}$$

**Problem 13.11.** A cantilever of length 2 m carries a uniformly varying load of 25 kN/m at the free end to 75 kN/m at the fixed end. If  $E = 1 \times 10^5 \text{ N/mm}^2$  and  $I = 10^8 \text{ mm}^4$ , determine the slope and deflection of the cantilever at the free end.

**Sol.** Given :

Length,  $L = 2 \text{ m} = 2000 \text{ mm}$

Load at the free end  $= 25 \text{ kN/m} = \frac{25 \times 1000}{1000} = 25 \text{ N/mm}$

$$\begin{aligned} \text{Load at fixed end} &= 75 \text{ kN/m} = 75 \text{ N/mm} \\ \text{Value of } E &= 1 \times 10^5 \text{ N/mm}^2 \\ \text{Value of } I &= 10^8 \text{ mm}^4. \end{aligned}$$

The load acting on the cantilever is shown in Fig. 13.10. This load is equivalent to a uniformly distributed load of 25 kN/m (or 25 N/mm) over the entire length and a triangular load of zero intensity at free end and  $(75 - 25 = 50 \text{ kN/m}$  or  $50 \text{ N/mm}$ ) 50 N/mm at the fixed end.

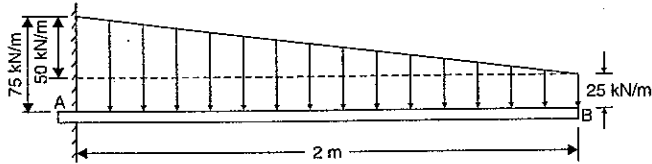

Fig. 13.10

(i) Slope at the free end

Let  $\theta_1$  = Slope at free end due to u.d.l. of 25 N/mm

$\theta_2$  = Slope at free end due to triangular load of intensity 50 N/mm at fixed end.

The slope at the free end due to u.d.l. of 25 N/mm (i.e.,  $w = 25 \text{ N/mm}$ ) is given by equation (13.5) as

$$\begin{aligned} \theta_1 &= \frac{wL^3}{6EI} && \text{(Here } \theta_1 = \theta_B, \text{ and } w = 25) \\ &= \frac{25 \times 2000^3}{6 \times 1 \times 10^5 \times 10^8} = 0.0033 \text{ rad.} \end{aligned}$$

The slope at the free end due to triangular load of intensity of 50 N/mm (i.e.  $w = 50 \text{ N/mm}$ ) is given by equation (13.11) as

$$\begin{aligned} \theta_2 &= \frac{wL^3}{24EI} \\ &= \frac{50 \times 2000^3}{24 \times 1 \times 10^5 \times 10^8} && \text{(Here } w = 50 \text{ N/mm)} \\ &= 0.00167 \text{ rad.} \end{aligned}$$

$$\begin{aligned} \therefore \text{ Total slope at the free end} \\ &= \theta_1 + \theta_2 = 0.0033 + 0.00167 = \mathbf{0.00497. \text{ Ans.}} \end{aligned}$$

(ii) Deflection at the free end

Let  $y_1$  = Deflection at the free end due to u.d.l. of 25 N/mm

$y_2$  = Deflection at the free end due to triangular load.

Using equation (13.11), we get deflection at the free end due to u.d.l.

$$\therefore y_1 = \frac{wL^4}{8EI} = \frac{25 \times 2000^4}{8 \times 1 \times 10^5 \times 10^8} = 5 \text{ mm}$$

Using equation (13.12), we get deflection at the free end to uniformly varying load of zero at the free end and 50 N/mm at the fixed end.

$$\therefore y_2 = \frac{wL^4}{30EI} = \frac{50 \times 2000^4}{30 \times 1 \times 10^5 \times 10^8} = 2.67 \text{ mm}$$

$$\begin{aligned} \therefore \text{ Total deflection at the free end} \\ &= y_1 + y_2 = 5 + 2.67 = \mathbf{7.67 \text{ mm. \text{ Ans.}}} \end{aligned}$$

### 13.8. DEFLECTION AND SLOPE OF A CANTILEVER BY MOMENT AREA METHOD

The moment area method is discussed in Art. 12.8, where this method was applied to a simply supported beam. Let us apply this method to a cantilever. According to this method the change of slope between any two points is equal to the net area of the B.M. diagram between these two points divided by  $EI$ . If one of the points is having zero slope, then we can obtain the slope at the other point.

Similarly if the deflection at a point A is zero, then the deflection at the point B according to this method is given by

$$y = \frac{A\bar{x}}{EI}$$

where  $A$  = Area of B.M. diagram between A and B, and

$\bar{x}$  = Distance of C.G. of the area A from B.

**13.8.1. Cantilever Carrying a Point Load at the Free end.** Fig. 13.11 (a) shows a cantilever of length  $L$  fixed at end A and free at the end B. It carries a point load  $W$  at B.

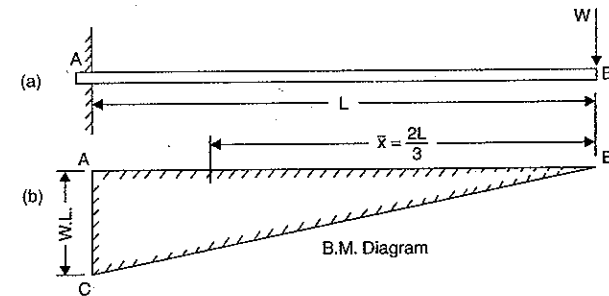

Fig. 13.11

The B.M. will be zero at B and will be  $WL$  at A. The variation of B.M. between A and B is linear as shown in Fig. 13.11 (b).

At the fixed end A, the slope and deflection are zero.

Let  $\theta_B$  = Slope at B i.e.,  $\left(\frac{dy}{dx}\right)$  at B and

$y_B$  = Deflection at B

Then according to moment area method,

$$\begin{aligned} \theta_B &= \frac{\text{Area of B.M. Diagram between A and B}}{EI} \\ &= \frac{\frac{1}{2} \times AB \times AC}{EI} && \text{(Area of triangle ABC)} \\ &= \frac{\frac{1}{2} \times L \times W.L}{EI} = \frac{WL^2}{2EI} \end{aligned}$$

and 
$$y_B = \frac{A\bar{x}}{EI} \quad \dots(i)$$

where  $A = \text{Area of B.M. diagram between A and B} = \frac{W \cdot L^2}{2}$

$\bar{x} = \text{Distance of C.G. of area of B.M. diagram from B} = \frac{2L}{3}$

$$y_B = \frac{\frac{W \cdot L^2}{2} \times \frac{2L}{3}}{EI} = \frac{W \cdot L^3}{3EI}$$

**13.8.2. Cantilever Carrying a Uniformly Distributed load.** Fig. 13.12 (a) shows a cantilever of length  $L$  fixed at end  $A$  and free at the end  $B$ . It carries a uniformly distributed load of  $w/\text{unit length}$  over the entire length.

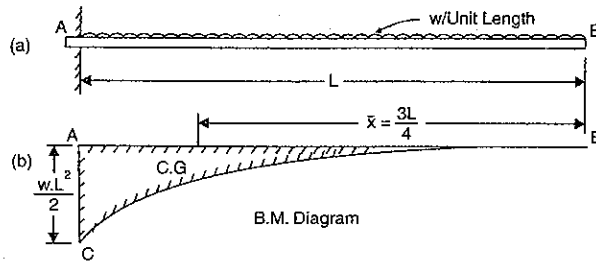

Fig. 13.12

The B.M. will be zero at  $B$  and will be  $\frac{w \cdot L^2}{2}$  at  $A$ . The variation of B.M. between  $A$  and  $B$  is parabolic as shown in Fig. 13.12 (b). At the fixed end  $A$ , the slope and deflection are zero.

Area of B.M. diagram (ABC),  $A = \frac{1}{3} \cdot L \cdot \frac{w \cdot L^2}{2} = \frac{w \cdot L^3}{6}$

and the distance of the C.G. of the B.M. diagram from  $B$ ,

$$\bar{x} = \frac{3L}{4}$$

Let  $\theta_B = \text{Slope at B, i.e., } \left(\frac{dy}{dx}\right)$  and at  $B$

$y_B = \text{Deflection at B.}$

Then according to moment area method,

$$\theta_B = \frac{\text{Area of B.M. diagram}}{EI} = \frac{wL^3}{6EI}$$

$$y_B = \frac{A\bar{x}}{EI} = \frac{w \cdot L^3}{6EI} \times \frac{3L}{4} = \frac{w \cdot L^4}{8EI}$$

and

**13.8.3. Cantilever Carrying a Uniformly Distributed Load upto a Length 'a' from the Fixed end.** Fig. 13.13 (a) shows a cantilever of length  $L$  fixed at end  $A$  and free at the end  $B$ . It carries a uniformly distributed load of  $w/\text{unit length}$  over a length 'a' from the fixed end.

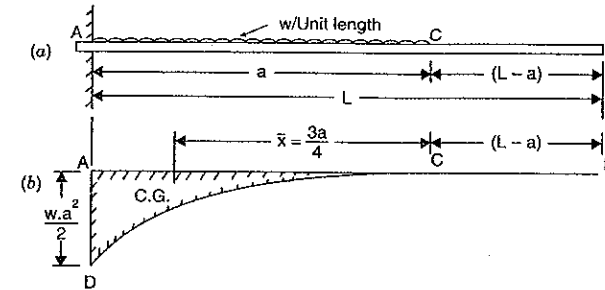

Fig. 13.13

The B.M. will be zero at  $B$  and  $C$ . But B.M. at  $A$  will be  $\frac{w \cdot a^2}{2}$ . The variation of B.M. between  $C$  and  $A$  will be parabolic as shown in Fig. 13.13 (b). At the fixed end the slope and deflection are zero.

Area of B.M. diagram  $A = \frac{1}{3} \cdot a \cdot \frac{w \cdot a^2}{2} = \frac{w \cdot a^3}{6}$

and the distance of the C.G. of B.M. diagram from  $B$ ,

$$\bar{x} = (L - a) + \frac{3a}{4}$$

Let  $\theta_B = \text{Slope at B i.e., } \left(\frac{dy}{dx}\right)$  at  $B$  and

$y_B = \text{Deflection at B.}$

Then according to moment area method,

$$\theta_B = \frac{A}{EI} = \frac{w \cdot a^3}{6EI}$$

and

$$y_B = \frac{A\bar{x}}{EI} = \frac{w \cdot a^3}{6EI} \times \left[ (L - a) + \frac{3a}{4} \right] = \frac{w \cdot a^3}{6EI} (L - a) + \frac{w \cdot a^4}{8EI}$$

**Problem 13.12.** A cantilever of length 2 m carries a point load of 20 kN at the free end and another load of 20 kN at its centre. If  $E = 10^5 \text{ N/mm}^2$  and  $I = 10^8 \text{ mm}^4$  for the cantilever then determine by moment area method, the slope and deflection of the cantilever at the free end.

**Sol. Given :**

Length,  $L = 2 \text{ m}$

Load at free end,  $W_1 = 20 \text{ kN} = 20000 \text{ N}$

Load at centre,  $W_2 = 20 \text{ kN} = 20000 \text{ N}$

Value of  $E = 10^5 \text{ N/mm}^2$

Value of  $I = 10^8 \text{ mm}^4$

First draw the B.M. diagram,

B.M. at  $B = 0$

B.M. at  $C = -20 \times 1 = -20 \text{ kNm} = -20 \times 10^3 \times 10^3 \text{ Nmm}$

$$\text{B.M. at A} = -20 \times 1 - 20 \times 2 = -60 \text{ kNm} = -60 \times 10^3 \times 10^3 \text{ Nmm}$$

B.M. diagram is shown in Fig. 13.14 (b).

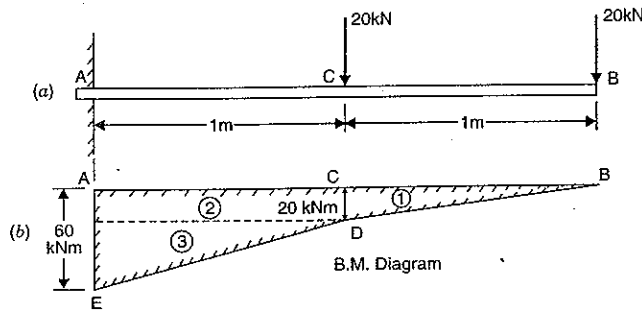

Fig. 13.14

To find the area of B.M. diagram, divide the Fig. 13.14 (b) into two triangles and one rectangle.

$$\begin{aligned} \text{Now area } A_1 &= \frac{1}{2} \times CD \times BC = \frac{1}{2} \times 20 \times 1 \\ &= 10 \text{ kNm}^2 = 10 \times 10^3 \times 10^6 \text{ Nmm}^2 \quad (\because \text{m}^2 = 10^6 \text{ mm}^2) \\ &= 10^{10} \text{ Nmm}^2 \end{aligned}$$

$$\text{Similarly area } A_2 = CD \times AC = 20 \times 1 = 20 \text{ kNm}^2$$

$$\text{and area } A_3 = \frac{1}{2} \times FD \times EF = \frac{1}{2} \times 1 \times 40 = 20 \text{ kNm}^2$$

$\therefore$  Total area of B.M. diagram,

$$\begin{aligned} A &= A_1 + A_2 + A_3 = 10 + 20 + 20 = 50 \text{ kNm}^2 \\ &= 50 \times 10^3 \times 10^6 \text{ Nmm}^2 \quad (\because \text{m}^2 = 10^6 \text{ mm}^2) \end{aligned}$$

Slope and deflection at the fixed end is zero.

Let  $\theta_B =$  Slope at the free end B.

Then according to the moment area method,

$$\begin{aligned} \theta_B &= \frac{\text{Area of B.M. diagram}}{EI} \\ &= \frac{50 \times 10^3 \times 10^6}{10^5 \times 10^8} = 0.005 \text{ radians. Ans.} \end{aligned}$$

Let  $y_B =$  Deflection at the free end B.

Then according to moment area method,

$$y_B = \frac{A\bar{x}}{EI} \quad \dots(i)$$

Now let us find  $\bar{x}$  or  $A\bar{x}$ .

Then total moment of the bending moment diagram about B is given by

$$\begin{aligned} A \cdot \bar{x} &= A_1\bar{x}_1 + A_2\bar{x}_2 + A_3\bar{x}_3 \\ &= 10 \times \left(\frac{2}{3} \times 1\right) + 20 \times \left(1 + \frac{1}{2}\right) + 20 \times \left(1 + \frac{2}{3} \times 1\right) \end{aligned}$$

$$\begin{aligned} &= \frac{20}{3} + 30 + \frac{100}{3} = 70 \text{ kNm}^3 \\ &= 70 \times 10^3 \times 10^9 \text{ Nmm}^3 \quad (\because \text{m}^3 = 10^9 \text{ mm}^3) \\ &= 7 \times 10^{13} \text{ Nmm}^3 \end{aligned}$$

Substituting this value in equation (i), we get

$$y_B = \frac{7 \times 10^{13}}{10^5 \times 10^8} = 7 \text{ mm. Ans.}$$

### HIGHLIGHTS

- The slope i.e.,  $\frac{dy}{dx}$  or  $\theta$  of a cantilever at the free end is given by,

$$\theta_B = \frac{WL^2}{2EI} \quad \text{when the point load is at the free end}$$

$$\theta_B = \theta_C = \frac{W\alpha^2}{2EI} \quad \text{when the point load is at a distance of 'a' from the fixed end}$$

$$\theta_B = \frac{w \cdot L^2}{6EI} \quad \text{when it carries a uniformly distributed load over the whole length.}$$

$$\theta_B = \theta_C = \frac{w\alpha^3}{6EI} \quad \text{when it carries a uniformly distributed load over a length 'a' from the fixed end.}$$

$$\theta_B = \frac{w \cdot L^3}{6EI} - \frac{w \cdot (L - a)^3}{6EI} \quad \text{when it carries a uniformly distributed load over a distance 'a' from the free end}$$

$$\theta_B = \frac{w \cdot L^3}{24EI} \quad \text{when it carries a gradually varying load from zero at the free end to } w/\text{m run at fixed end.}$$

where  $W =$  Point load,

$w =$  Uniformly distributed load,

$L =$  Length of beam,

$I =$  Moment of inertia, and

$E =$  Young's modulus.

- The deflection i.e.,  $y$  of a cantilever of length  $L$ , at the free end is given by,

$$y_B = \frac{WL^3}{3EI} \quad \text{when the point load is at the free end}$$

$$y_B = \frac{W\alpha^3}{3EI} + \frac{W\alpha^2}{2EI} (L - a) \quad \text{when the point load is at a distance of 'a' from the fixed end}$$

$$y_B = \frac{wL^4}{8EI} \quad \text{when it carries a uniformly distributed load over the whole length}$$

$$y_B = \frac{w\alpha^4}{8EI} + \frac{w \cdot \alpha^3}{6EI} (L - a) \quad \text{when it carries a uniformly distributed load over a length 'a' from the fixed end.}$$

$$\begin{aligned} &= \frac{W \cdot b}{W \cdot a \cdot b} (L^2 - b^2) \cdot a - \left( \frac{1}{2} \times a \times \frac{EIL}{W \cdot a \cdot b} \right) \times \left( \frac{3}{a} \right) \\ &= \frac{6EIL}{W \cdot a \cdot b} (L^2 - b^2) - \frac{6EIL}{W \cdot a \cdot b} \\ &= \frac{6EIL}{W \cdot a \cdot b} [L^2 - b^2 - a^2]. \end{aligned}$$

**Problem 14.1.** A simply supported beam of length 5 m carries a point load of 5 kN at a distance of 3 m from the left end. If  $E = 2 \times 10^5 \text{ N/mm}^2$  and  $I = 10^8 \text{ mm}^4$ , determine the slope at the left support and deflection under the point load using conjugate beam method.

**Sol. Given :**

Length,  $L = 5 \text{ m}$   
 Point load,  $W = 5 \text{ kN}$   
 Distance AC,  $a = 3 \text{ m}$   
 Distance BC,  $b = 5 - 3 = 2 \text{ m}$   
 Value of  $E = 2 \times 10^5 \text{ N/mm}^2 = 2 \times 10^6 \text{ N/m}^2$   
 Value of  $I = 1 \times 10^8 \text{ mm}^4 = 10^{-4} \text{ m}^4$

and

Let  $R_A = \text{Reaction at A}$   
 $R_B = \text{Reaction at B}$   
 Taking moments about A, we get

$$R_B \times 5 = 5 \times 3$$

$$R_B = \frac{5}{5} \times 3 = 3 \text{ kN}$$

$$R_A = \text{Total load} - R_B = 5 - 3 = 2 \text{ kN}$$

and

The B.M. at A = 0

B.M. at B = 0

$$\text{B.M. at C} = R_A \times 3 = 2 \times 3 = 6 \text{ kNm.}$$

Now B.M. diagram is drawn as shown in Fig. 14.3 (b).

Now construct the conjugate beam as shown in Fig. 14.3 (c). The vertical load at C\* on

conjugate beam

$$\text{B.M. at C} = \frac{EI}{6} \text{ kNm}$$

Now calculate the reaction at A\* and B\* for conjugate beam

Let  $R_A^* = \text{Reaction at A}^*$  for conjugate beam

$R_B^* = \text{Reaction at B}^*$  for conjugate beam.

Taking moments about A\*, we get

$$R_B^* \times 5 = \text{Load on A}^*C^*D^* \times \text{distance of C.G. of A}^*C^*D^* \text{ from A}^* \\ + \text{Load on B}^*C^*D^* \times \text{Distance of C.G. of B}^*C^*D^* \text{ from A}^*$$

$$= \left( \frac{1}{2} \times 3 \times \frac{EI}{6} \right) \times \left( \frac{3}{2} \times 3 \right) + \left( \frac{1}{2} \times 2 \times \frac{EI}{6} \right) \times \left( 3 + \frac{3}{2} \times 2 \right)$$

$$= \frac{18}{18} \times \frac{EI}{11} + \frac{EI}{6} \times \frac{3}{8} = \frac{EI}{22} + \frac{EI}{8} = \frac{EI}{40}$$

$$R_B^* = \frac{40}{8} \times \frac{EI}{5} = \frac{EI}{1}$$

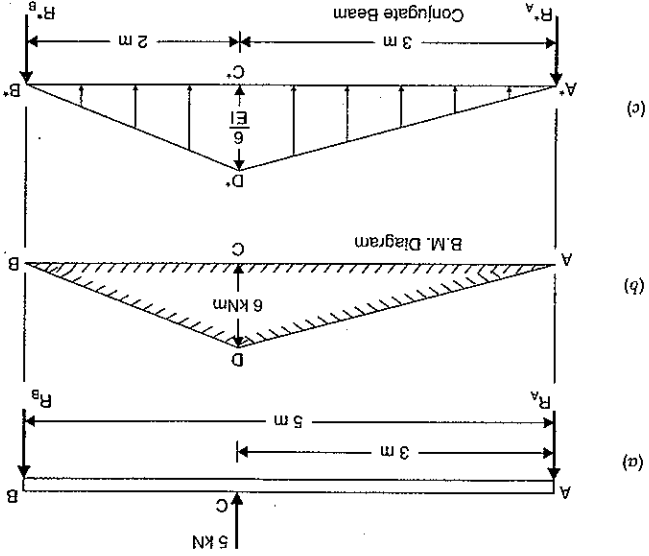

Fig. 14.3

$$R_A^* = \text{Total load (i.e., load A}^*B^*D^*) - R_B^*$$

$$= \left( \frac{1}{2} \times 5 \times \frac{EI}{8} \right) - \frac{EI}{8}$$

$$= \frac{EI}{16} - \frac{EI}{8} = \frac{EI}{8}$$

Let  $\theta_A = \text{Slope at A for the given beam i.e., } \left( \frac{dy}{dx} \right) \text{ at A}$

$y_C = \text{Deflection at C for the given beam}$

Then according to conjugate beam method,

$\theta_A = \text{Shear force at A}^* \text{ for conjugate beam} = R_A^*$

$$\frac{EI}{7} = \frac{2 \times 10^6 \times 10^{-4}}{7} \quad (\because E = 2 \times 10^6 \text{ kN/m}^2 \text{ and } I = 10^{-4} \text{ m}^4)$$

**Ans. = 0.00035 radians.**

$y_C = \text{B.M. at C}^* \text{ for conjugate beam}$

$= R_A^* \times 3 - \text{Load A}^*C^*D^* \times \text{Distance of C.G. of A}^*C^*D^* \text{ from C}^*$

$$= \frac{EI}{7} \times 3 - \left( \frac{1}{2} \times 3 \times \frac{EI}{6} \right) \times \left( \frac{3}{2} \times 3 \right)$$

$$= \frac{21}{12} \frac{EI}{9} - \frac{EI}{12}$$

$$= \frac{2 \times 10^6 \times 10^{-4}}{12} - \frac{10^4}{6} = \frac{6 \times 1000}{6} \text{ mm} = 0.6 \text{ mm. Ans.}$$



Construct now the conjugate beam. The load at any point on the conjugate beam will be equal to B.M. at that point divided by  $EI$ . Fig. 14.2 (c) shows the conjugate beam with the loads. The vertical load on conjugate beam at  $C^*$  will be  $\frac{M}{W \cdot a \cdot b} = \frac{L \times EI}{EI \cdot L}$ .

Let  $R_A^*$  = Reaction at  $A$  for conjugate beam

$R_B^*$  = Reaction at  $B$  for conjugate beam

Taking moments about  $A$  of the conjugate beam, we get

$R_B^* \cdot L$  = Load  $AC^*D^*$   $\times$  Distance of C.G., of  $AC^*D^*$  from  $A$  + Load  $BC^*D^*$   $\times$  Distance of C.G., of  $BC^*D^*$  from  $A$

$$= \left( \frac{1}{2} \times AC^* \times C^*D^* \right) \times \left( \frac{1}{2} \cdot BC^* \cdot C^*D^* \right) \times \left( AC^* + \frac{3}{1} \times BC^* \right) = \left( \frac{1}{2} \times a \times \frac{W \cdot a \cdot b}{EI \cdot L} \right) \times \left( \frac{3}{2} \times a \right) + \left( \frac{1}{2} \times b \times \frac{W \cdot a \cdot b}{EI \cdot L} \right) \times \left( a \times \frac{3}{b} \right) = \frac{3EI}{W \cdot a^3 \cdot b} + \frac{2EI}{W \cdot a \cdot b^3} \left( a + \frac{3}{b} \right)$$

$$= \frac{W \cdot a^3 \cdot b}{3EI} + \frac{2EI}{W \cdot a \cdot b^3}$$

$$= \frac{W \cdot a \cdot b}{2a^2 + b^2 + 2ab + a^2 + ab} \left[ \frac{3EI}{2a^3} + \frac{2EI}{W \cdot a \cdot b^3} \right]$$

$$= \frac{W \cdot a \cdot b}{6EI} [2a^2 + 3ab + b^2]$$

$$= \frac{W \cdot a \cdot b}{6EI} (a + b)^2 + a(a + b)$$

$$= \frac{W \cdot a \cdot b}{6EI} [L^2 + a \cdot L]$$

$$= \frac{W \cdot a \cdot (L - a)}{6EI} \cdot [L(L + a)] = \frac{W \cdot a}{6EI} [L^2 - a^2]$$

$$\therefore R_B^* = \frac{W \cdot a}{6EI} (L^2 - a^2)$$

Similarly the reaction at  $A$  can be obtained as

$$R_A^* = \frac{W \cdot b}{6EI} (L^2 - b^2)$$

Let  $\theta_A$  = Slope at  $A$  for the given beam i.e.,  $\left( \frac{dy}{dx} \right)$  at  $A$

$y_C$  = Deflection at  $C$  for the given beam.

Then according to conjugate beam method,

$\theta_A$  = Shear force at  $A$  for the conjugate beam

$= R_A^*$

$\therefore$  S.F. at  $A$  for conjugate beam =  $R_A^*$

$y_C$  = B.M. at  $C$  for conjugate beam

$$= \frac{6EI}{W \cdot b} (L^2 - b^2)$$

[See Fig. 14.2 (c)]

$= R_A^* \cdot a$  - Load  $AC^*D^*$   $\times$  Distance of C.G. of  $AC^*D^*$  from  $C^*$

$$= R_A^* \cdot \frac{WL^2}{16EI} - \left( \frac{2}{1} \times \frac{WL}{2} \times \frac{4EI}{3} \right) \times \left( \frac{1}{3} \times \frac{L}{2} \right) = \frac{WL^2}{32EI} - \frac{3WL^3}{96EI} = \frac{WL^2}{48EI}$$

$\times$  Distance of C.G. of  $AC^*D^*$  from  $C$

$= R_A^* \times \frac{L}{2}$  - Load corresponding to  $AC^*D^*$

$y_C$  = B.M. at  $C$  for the conjugate beam [See Fig. 14.1 (c)]

and

$\therefore$  S.F. at  $A$  for conjugate beam =  $R_A^*$

Fig. 14.2 (a) shows a beam  $AB$  of length  $L$ , simply supported at  $A$  and  $B$  and carrying a point load of  $W$  at a distance ' $a$ ' from the end  $A$ . The reactions at  $A$  and  $B$  are given by

$$R_A = \frac{W \cdot b}{L} \quad \text{and} \quad R_B = \frac{W \cdot a}{L}$$

The B.M. will be zero at  $A$  and  $B$ . At  $C$ , the B.M. will be  $R_A \times a = \frac{L}{W \cdot b} \times a = \frac{L}{W \cdot a \cdot b}$

Now the B.M. diagram can be drawn as shown in Fig. 14.2 (b).

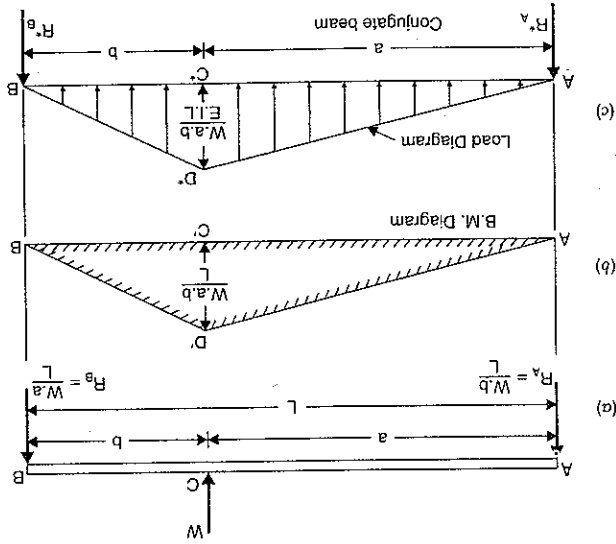

Fig. 14.2

# Conjugate Beam Method, Propped Cantilevers and Beams

## 14.1. INTRODUCTION

The slopes and deflections of beams and cantilevers may be obtained from various methods like double integration method, moment area method, Macaulay's method, etc. But these methods become laborious, when applied to beams whose flexural rigidity (*i.e.*, the product of *E* and *I* is known as flexural rigidity) is not uniform throughout the length of the beam. The slopes and deflections of such beams can be easily obtained by conjugate beam method.

## 14.2. CONJUGATE BEAM METHOD

Before describing the conjugate beam method, let us first define conjugate beam.

Conjugate beam is an imaginary beam of length equal to that of the original beam but for which the load diagram is the  $\frac{M}{EI}$  diagram\* (*i.e.*, the load at any point on the conjugate beam is equal to *B.M.* at that point divided by *EI*).

The slopes and deflection at any section of a beam by conjugate beam method is given by :

1. The slope at any section of the given beam is equal to the shear force at the corresponding section of the conjugate beam.
2. The deflection at any section for the given beam is equal to the bending moment at the corresponding section of the conjugate beam.

Hence before applying the conjugate beam method, conjugate beam is constructed. The load on the conjugate beam at any point is equal to the *B.M.* at that point divided by *EI*. Hence the loading on the conjugate beam is known. Then the shear force at any point on the conjugate beam gives the slope at the corresponding point of actual beam. And the *B.M.* at any point on the conjugate beam gives the deflection at the corresponding point of the actual beam.

## 14.3. DEFLECTION AND SLOPE OF A SIMPLY SUPPORTED BEAM WITH A POINT LOAD AT THE CENTRE

Fig. 14.1 (a) shows a simply supported beam *AB* of length *L* carrying a point load *W* at the centre *C*. The *B.M.* at *A* and *B* is zero and at the centre *B.M.* will be  $\frac{W.L}{4}$ . The *B.M.* varies according to straight line law. The *B.M.* diagram is shown in Fig. 14.1 (b). Now the conjugate beam *AB* can be constructed. The load on the conjugate beam will be obtained by  $\frac{M}{EI}$  diagram is a diagram which shows the variation of  $\frac{M}{EI}$  over the length of the beam.

dividing the *B.M.* at that point by *EI*. The shape of loading on the conjugate beam will be same as of *B.M.* diagram. The ordinate of loading on conjugate beam will be equal to  $\frac{M}{EI} = \frac{W \times L}{4EI}$ . Hence ordinate at the centre will be  $\frac{W.L}{4EI}$  as shown in Fig. 14.1 (c). The load diagram for conjugate beam is shown in Fig. 14.1 (c).

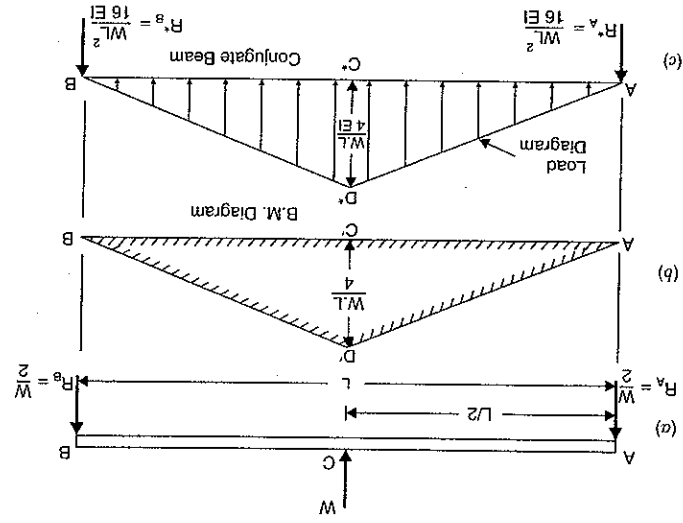

Fig. 14.1

Let  $R_A^*$  = Reaction at *A* for conjugate beam

$R_B^*$  = Reaction at *B* for conjugate beam

Total load on the conjugate beam [See Fig. 14.1 (c)]

= Area of the load diagram

$$= \frac{1}{2} \times AB \times C^*D^* = \frac{1}{2} \times L \times \frac{4EI}{WL}$$

$$= \frac{WL^2}{8EI}$$

Reaction at each support for the conjugate beam will be half of the total load

$$R_A^* = R_B^* = \frac{1}{2} \times \frac{WL^2}{8EI} = \frac{WL^2}{16EI}$$

Let  $\theta_A$  = Slope at *A* for the given beam *i.e.*,  $\left(\frac{dy}{dx}\right)$  at *A*

$y_c$  = deflection at *C* for the given beam.

Then according to conjugate beam method,

$$\theta_A = \text{Shear force at } A \text{ for the conjugate beam}$$

$$y_B = \frac{wL^4}{4EI} - \left[ \frac{w(L-a)^4}{8EI} + \frac{w(L-a)^3}{6EI} \times a \right]$$

when it carries a uniformly distributed load over a length 'a' from the free end

$$y_B = \frac{wL^4}{30EI}$$

when it carries a gradually varying load from zero at the free end to

3. For a cantilever, at the fixed end slope and deflections are zero. Hence moment area method can be easily applied for finding slope and deflections of cantilevers. The slope ( $\theta_B$ ) and deflection ( $y_B$ ) at the free end is given by,

$$\theta_B = \frac{\text{Area of B.M. diagram between free end and fixed end}}{EI}$$

and

$$y_B = \frac{A\bar{x}}{EI}$$

where A = Area of B.M. Diagram and

$\bar{x}$  = Distance of C.G. of B.M. diagram from free end.

4. Area of B.M. diagram sometimes is found easily by splitting the combined areas into triangles and rectangles.

### (A) Theoretical Questions

1. What is a cantilever? What are the different methods of finding of slope and deflection of a cantilever?

2. Derive an expression for the slope and deflection of a cantilever of length L, carrying a point load W at the free end by double integration method.

3. Solve question 2, by moment area method.

4. Prove that the slope and deflection of a cantilever carrying uniformly distributed load over the whole length are given by,

$$\theta_B = \frac{wL^3}{6EI} \quad \text{and} \quad y_B = \frac{wL^4}{8EI}$$

where  $w$  = Uniformly distributed load and

$EI$  = Flexural rigidity.

5. Find the expression for the slope and deflection of a cantilever of length L which carries a uniformly distributed load over a length 'a' from the fixed end by

(i) Double integration method and

(ii) Moment area method.

6. Prove that the slope and deflection of a cantilever length L, which carries a gradually varying load from zero at the free end to  $w/m$  run at the fixed end are given by :

$$\theta_B = \frac{wL^3}{24EI} \quad \text{and} \quad y_B = \frac{wL^4}{30EI}$$

where  $EI$  = Flexural rigidity.

### (B) Numerical Problems

1. A cantilever of length 2 m carries a point load of 30 kN at the free end. If moment of inertia  $I = 10^8 \text{ mm}^4$  and value of  $E = 2 \times 10^5 \text{ N/mm}^2$ , then find :

(i) slope of the cantilever at the free end and

(ii) deflection at the free end.

[Ans. (i) 0.003 rad., (ii) 4 mm]

2. A cantilever of length 3 m carries a point load of 60 kN at a distance of 2 m from the fixed end. If  $E = 2 \times 10^5$  and  $I = 10^8$ , find :

(i) slope at the free end and

(ii) deflection at the free end.

[Ans. 0.006 rad., 14 mm]

3. A cantilever of length 30 m carries a uniformly distributed load of 24 kN/m length over the entire length. If moment of inertia of the beam =  $10^8 \text{ mm}^4$  and value of  $E = 2 \times 10^5 \text{ N/mm}^2$ , determine the slope and deflection at the free end.

4. A cantilever of length 3 m carries a uniformly distributed load over the entire length. If the slope at the free end is 0.01777 radians, find the deflection at the free end.

5. Determine the slope and deflection at the free end of a cantilever of length 4 m which is carrying a uniformly distributed load of 12 kN/m over a length of 3 m from the fixed end. Take  $EI = 2 \times 10^{13} \text{ N/mm}^2$ .

6. A cantilever of length 3 m carries a uniformly distributed load of 15 kN/m over a length of 2 m from the free end. If  $I = 10^8 \text{ mm}^4$  and  $E = 2 \times 10^5 \text{ N/mm}^2$ , find :

(i) slope at the free end and

(ii) deflection at the free end.

7. A cantilever of length 2 m carries a load of 20 kN at the free end and 30 kN at a distance 1 m from the end. Find the slope and deflection at the free end. Take  $E = 2.0 \times 10^5 \text{ N/mm}^2$  and  $I = 1.5 \times 10^8 \text{ mm}^4$ .

8. Determine the deflection at the free end of a cantilever which is 2 m long and carries a point load of 9 kN at the free end and a uniformly distributed load of 8 kN/m over a length of 1 m from the fixed end.

9. Take  $I = 2.25 \times 10^7 \text{ mm}^4$  and  $E = 2.2 \times 10^5 \text{ N/mm}^2$ .

A cantilever of length 2 m carries a uniformly varying load of zero intensity at the free end, and 45 kN/m at the fixed end. If  $E = 2 \times 10^5 \text{ N/mm}^2$  and  $I = 10^8 \text{ mm}^4$ , find the slope and deflection of the free end.

10. A cantilever of length 2 m carries a point load of 30 kN at the free end and another load of 30 kN at its centre. If  $EI = 10^{13} \text{ N/mm}^2$  for the cantilever then determine by moment area method, the slope and deflection at the free end of cantilever.

11. A cantilever of length 'L' carries a U.D.L. of  $w$  per unit for a length of  $\frac{2}{L}$  from the fixed end.

Determine the slope and deflection at the free end using area moment method.

(Bangalore University, 1990)

[Hint. See Article 13.8.3 on page 572. Here  $a = \frac{2}{L}$ . Hence slope at free end,

$$\theta_B = \frac{6EI}{w \times a^3} \times \left( \frac{L}{2} \right) \times \left( \frac{2}{L} \right) \times \left( \frac{2}{L} \right) \times \left( \frac{2}{L} \right) = \frac{6EI}{48EI}$$

and deflection at free end,

$$y_B = \frac{6EI}{w \times a^3} (L-a) + \frac{8EI}{w \times a^4}$$

$$= \frac{6EI}{w \times \left( \frac{2}{L} \right)^3} \times \left( L - \frac{2}{L} \right) + \frac{8EI}{w \times \left( \frac{2}{L} \right)^4} = \frac{6EI}{L} \times \left( \frac{L}{2} - \frac{2}{L} \right) + \frac{128EI}{w \times L^4} = \frac{3EI}{L} + \frac{128EI}{w \times L^4}$$

$$= \frac{96EI}{w \times L^4} + \frac{128EI}{w \times L^4} = \frac{224EI}{w \times L^4} = \frac{96}{1} + \frac{128}{4+3} = \frac{128 \times 3}{EI}$$

[Ans.

**Problem 14.2.** A simply supported beam of length 4 m carries a point load of 3 kN at a distance of 1 m from each end. If  $E = 2 \times 10^5 \text{ N/mm}^2$  and  $I = 10^8 \text{ mm}^4$  for the beam, then using conjugate beam method determine:

- (i) slope at each end and under each load  
 (ii) deflection under each load and at the centre.

**Sol. Given :**

Length,  $L = 4 \text{ m}$   
 Value of  $E = 2 \times 10^5 \text{ N/mm}^2 = 2 \times 10^5 \times 10^6 \text{ N/m}^2$   
 $= 2 \times 10^5 \times 10^3 \text{ kN/m}^2 = 2 \times 10^8 \text{ kN/m}^2$

Value of  $I = 10^8 \text{ mm}^4 = \frac{10^8}{10^{12}} \text{ m}^4 = 10^{-4} \text{ m}^4.$

As the load on the beam is symmetrical as shown in Fig. 14.4 (a), the reactions  $R_A$  and  $R_B$  will be equal to 3 kN.

Now B.M. at A and B are zero.

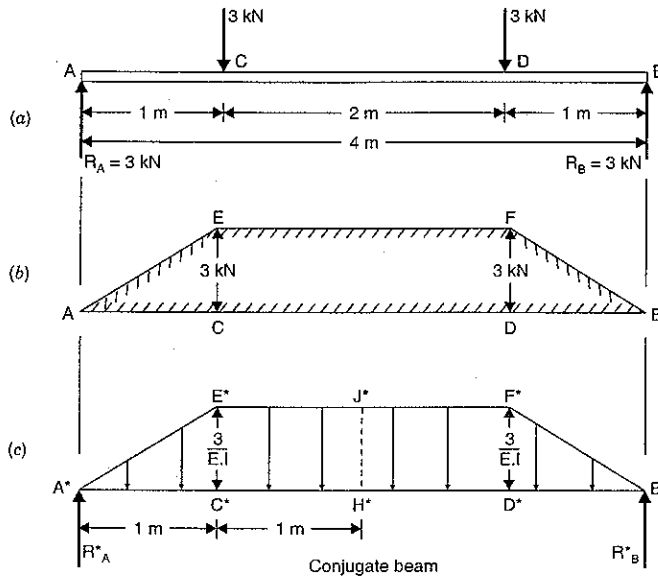

Fig. 14.4

B.M. at C =  $R_A \times 1 = 3 \times 1 = 3 \text{ kNm}$

B.M. at D =  $R_B \times 1 = 3 \times 1 = 3 \text{ kNm}$

Now B.M. diagram can be drawn as shown in Fig. 14.4 (b).

Now by dividing the B.M. at any section by  $EI$ , we can construct the conjugate beam as shown in Fig. 14.4 (c). The loading are shown on the conjugate beam.

Let  $R_{A^*}$  = Reaction at  $A^*$  for the conjugate beam and  
 $R_{B^*}$  = Reaction at  $B^*$  for conjugate beam

The loading on the conjugate beam is symmetrical

$$\begin{aligned} \therefore R_{A^*} &= R_{B^*} = \text{Half of total load on conjugate beam} \\ &= \frac{1}{2} [\text{Area of trapezoidal } A^*B^*F^*E^*] \\ &= \frac{1}{2} \left[ \frac{(E^*F^* + A^*B^*)}{2} \times E^*C^* \right] \\ &= \frac{1}{2} \left[ \frac{(2+4)}{2} \times \frac{3}{EI} \right] = \frac{4.5}{EI} \end{aligned}$$

(i) Slope at each end and under each load

Let  $\theta_A$  = Slope at A for the given beam i.e.,  $\left(\frac{dy}{dx}\right)$  at A

$\theta_B$  = Slope at B for the given beam

$\theta_C$  = Slope at C for the given beam and

$\theta_D$  = Slope at D for the given beam

Then according to conjugate beam method,

$$\begin{aligned} \theta_A &= \text{Shear force at } A^* \text{ for conjugate beam} = R_{A^*} \\ &= \frac{4.5}{EI} = \frac{4.5}{2 \times 10^8 \times 10^{-4}} = 0.000225 \text{ rad. Ans.} \end{aligned}$$

$$\theta_B = R_{B^*} = \frac{4.5}{EI} = 0.000225 \text{ rad. Ans.}$$

$$\begin{aligned} \theta_C &= \text{Shear force at } C^* \text{ for conjugate beam} \\ &= R_{A^*} - \text{Total load } A^*C^*D^* \\ &= \frac{4.5}{EI} - \frac{1}{2} \times 1 \times \frac{3}{EI} = \frac{3}{EI} \\ &= \frac{3}{2 \times 10^8 \times 10^{-4}} = 0.00015 \text{ rad. Ans.} \end{aligned}$$

Similarly,  $\theta_D = 0.00015 \text{ rad. Ans.}$

(By symmetry)

(ii) Deflection under each load

Due to symmetry, the deflection under each load will be equal

Let  $y_C$  = Deflection at C for the given beam and

$y_D$  = Deflection at D for the given beam.

Now according to conjugate beam method,

$$\begin{aligned} y_C &= \text{B.M. at } C^* \text{ for conjugate beam} \\ &= R_{A^*} \times 1.0 - (\text{Load } A^*C^*E^*) \times \text{Distance of C.G. of } A^*C^*E^* \text{ from } C^* \\ &= \frac{4.5}{EI} \times 1 - \left( \frac{1}{2} \times 1 \times \frac{3}{EI} \right) \times \frac{1}{3} \\ &= \frac{4.5}{EI} - \frac{0.5}{EI} = \frac{4.0}{EI} \\ &= \frac{4}{2 \times 10^8 \times 10^{-4}} \text{ m} = \frac{4 \times 1000}{2 \times 10^4} \text{ mm} \\ &= 0.2 \text{ mm. Ans.} \end{aligned}$$

Also  $y_D = 0.2 \text{ mm.}$

Deflection at the centre of the beam

$$\begin{aligned}
 &= \text{B.M. at the centre of the conjugate beam} \\
 &= R_A^* \times 2.0 - \text{Load } A^*C^*E^* \\
 &\quad \times \text{Distance of C.G. of } A^*C^*E^* \text{ from the centre of beam} \\
 &\quad - \text{Load } C^*H^*J^*E^* \\
 &\quad \times \text{Distance of C.G. of } C^*H^*J^*E^* \text{ from the centre of beam} \\
 &= \frac{4.5}{EI} \times 2.0 - \left(\frac{1}{2} \times 1 \times \frac{3}{EI}\right) \times \left(1 + \frac{1}{3}\right) - \left(1 \times \frac{3}{EI}\right) \times \frac{1}{2} \\
 &= \frac{9}{EI} - \frac{2}{EI} - \frac{1.5}{EI} = \frac{6.5}{EI} \\
 &= \frac{6.5}{2 \times 10^8 \times 10^{-4}} \text{ m} = \frac{6.5 \times 1000}{2 \times 10^4} \text{ mm} \\
 &= \mathbf{0.325 \text{ mm. Ans.}}
 \end{aligned}$$

**Problem 14.3.** A simply supported beam  $AB$  of span  $4 \text{ m}$  carries a point load of  $100 \text{ kN}$  at its centre  $C$ . The value of  $I$  for the left half is  $1 \times 10^8 \text{ mm}^4$  and for the right half portion  $I$  is  $2 \times 10^8 \text{ mm}^4$ . Find the slopes at the two supports and deflection under the load.

Take  $E = 200 \text{ GN/m}^2$ .

**Sol. Given :**

Length,  $L = 4 \text{ m}$   
 Length  $AC = \text{Length } BC = 2 \text{ m}$   
 Point load,  $W = 100 \text{ kN}$   
 Moment of inertia for  $AC$

$$I = 1 \times 10^8 \text{ mm}^4 = \frac{10^8}{10^{12}} \text{ m}^4 = 10^{-4} \text{ m}^4$$

Moment of inertia for  $BC$

$$\begin{aligned}
 &= 2 \times 10^8 \text{ mm}^4 \\
 &= 2 \times 10^{-4} \text{ m}^4 = 2I \quad (\because 10^{-4} = I)
 \end{aligned}$$

Value of  $E = 200 \text{ GN/m}^2 = 200 \times 10^9 \text{ N/m}^2$   
 $= 200 \times 10^6 \text{ kN/m}^2$ .

The reactions at  $A$  and  $B$  will be equal, as point load is acting at the centre.

$$\therefore R_A = R_B = \frac{100}{2} = 50 \text{ kN}$$

Now B.M. at  $A$  and  $B$  are zero.

B.M. at  $C = R_A \times 2 = 50 \times 2 = 100 \text{ kNm}$

Now B.M. can be drawn as shown in Fig. 14.5 (b).

Now we can construct the conjugate beam by dividing B.M. at any section by the product of  $E$  and M.O.I.

The conjugate beam is shown in Fig. 14.5 (c). The loading are shown on the conjugate beam. The loading on the length  $A^*C^*$  will be  $A^*C^*D^*$  whereas the loading on length  $B^*C^*$  will be  $B^*C^*E^*$ .

$$\text{The ordinate } C^*D^* = \frac{\text{B.M. at } C}{E \times \text{M.O.I. for } AC} = \frac{100}{EI}$$

$$\text{The ordinate } C^*E^* = \frac{\text{B.M. at } C}{\text{Product of } E \text{ and M.O.I. for } BC} = \frac{100}{E \times 2I} = \frac{50}{EI}$$

Let  $R_A^*$  = Reaction at  $A^*$  for conjugate beam

$R_B^*$  = Reaction at  $B^*$  for conjugate beam

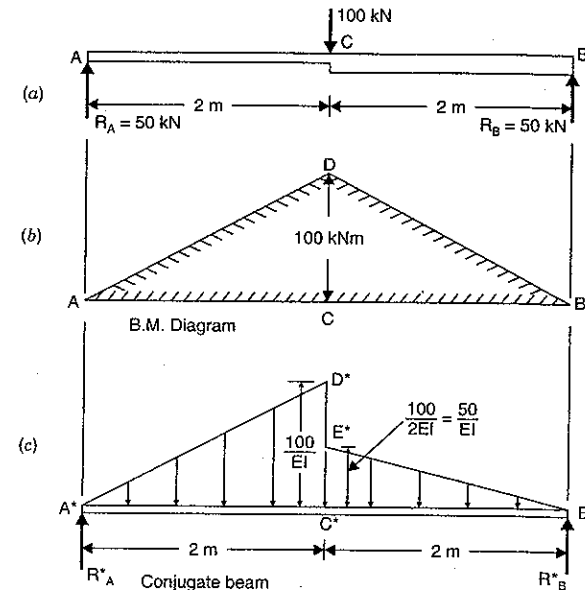

Fig. 14.5

First calculate  $R_A^*$  and  $R_B^*$

Taking moments of all forces about  $A^*$ , we get

$$\begin{aligned}
 R_B^* \times 4 &= \text{Load } A^*C^*D^* \times \text{Distance of C.G. of } A^*C^*D^* \text{ from } A \\
 &\quad + \text{Load } B^*C^*E^* \times \text{Distance of C.G. of } B^*C^*E^* \text{ from } A^* \\
 &= \left(\frac{1}{2} \times 2 \times \frac{100}{EI}\right) \times \left(\frac{2}{3} \times 2\right) + \left(\frac{1}{2} \times 2 \times \frac{50}{EI}\right) \times \left(2 + \frac{1}{3} \times 2\right) \\
 &= \frac{400}{3EI} + \frac{400}{3EI} = \frac{800}{3EI}
 \end{aligned}$$

$$R_B^* = \frac{200}{3EI}$$

and

$$R_A^* = \text{Total load on conjugate beam} - R_B^*$$

$$\begin{aligned}
 &= \left(\frac{1}{2} \times 2 \times \frac{100}{EI} + \frac{1}{2} \times 2 \times \frac{50}{EI}\right) - \frac{200}{3EI} \\
 &= \frac{150}{EI} - \frac{200}{3EI} = \frac{250}{3EI}
 \end{aligned}$$

(i) Slopes at the supports

Let  $\theta_A =$  Slope at A i.e.,  $\left(\frac{dy}{dx}\right)$  at A for the given beam $\theta_B =$  Slope at B i.e.,  $\left(\frac{dy}{dx}\right)$  at B for the given beam

The according to the conjugate beam method,

$$\theta_A = \text{Shear force at } A^* \text{ for conjugate beam} = R_A^*$$

$$= \frac{250}{3EI}$$

$$= \frac{250}{3 \times 200 \times 10^6 \times 10^4} = 0.004166 \text{ rad. Ans.}$$

and

$$\theta_B = \text{Shear force at } B^* \text{ for conjugate beam} = R_B^*$$

$$= \frac{200}{3EI} = \frac{200}{3 \times 200 \times 10^6 \times 10^4} = 0.003333 \text{ rad. Ans.}$$

(ii) Deflection under the load

Let  $y_C =$  Deflection at C for the given beam.

Then according to the conjugate beam method,

 $y_C =$  B.M. at point  $C^*$  of the conjugate beam
$$= R_A^* \times 2 - (\text{Load } A^*C^*D^*) \times \text{Distance of C.G. of } A^*C^*D^* \text{ from } C^*$$

$$= \frac{250}{3EI} \times 2 - \left(\frac{1}{2} \times 2 \times \frac{100}{EI}\right) \times \left(\frac{1}{3} \times 2\right)$$

$$= \frac{500}{3EI} - \frac{200}{3EI} = \frac{100}{EI}$$

$$= \frac{100}{200 \times 10^6 \times 10^{-4}} \text{ m}$$

$$= \frac{1}{200} \text{ m} = \frac{1}{200} \times 1000 = 5 \text{ mm. Ans.}$$

**Problem 14.4.** A beam ABCD is simply supported at its ends A and D over a span of 30 metres. It is made up of three portions AB, BC and CD each 10 m in length. The moments of inertia of the section of these portion are I, 3I and 2I respectively, where  $I = 2 \times 10^{10} \text{ mm}^4$ . The beam carries a point load of 150 kN at B and a point load of 300 kN at C. Neglecting the weight of the beam calculate the slopes and deflections at A, B, C and D. Take  $E = 2 \times 10^2 \text{ kN/mm}^2$ .

Sol. Given :

Length,  $L = 30 \text{ m}$ 

Length AB = Length BC = Length CD = 10 m

M.O.I. of AB,  $I = 2 \times 10^{10} \text{ mm}^4 = \frac{2 \times 10^{10}}{10^{12}} \text{ m}^4 = 2 \times 10^{-2} \text{ m}^4$ .M.O.I. of BC,  $3I = 6 \times 10^{-2} \text{ m}^4$ M.O.I. of CD,  $2I = 4 \times 10^{-2} \text{ m}^4$ 

Point load at B = 150 kN

Point load at C = 300 kN

Value of  $E = 2 \times 10^2 \text{ kN/mm}^2 = 2 \times 10^2 \times 10^6 \text{ kN/m}^2 = 2 \times 10^8 \text{ kN/m}^2$ 

Fig. 14.6

To find reactions  $R_A$  and  $R_D$ , take moments about A.

$$\therefore R_D \times 30 = 150 \times 10 + 300 \times 20 = 7500$$

$$\therefore R_D = \frac{7500}{30} = 250 \text{ kN}$$

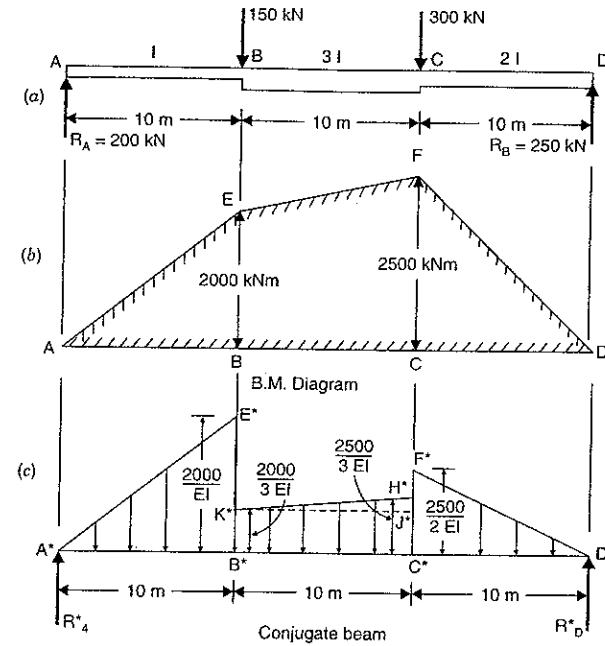
$$\therefore R_A = \text{Total load} - R_D$$

$$= (150 + 300) - 250 = 200 \text{ kN.}$$

Now draw B.M. diagram

B.M. at A and D = 0

B.M. at B =  $R_A \times 10 = 200 \times 10 = 2000 \text{ kNm}$ B.M. at C =  $R_D \times 10 = 250 \times 10 = 2500 \text{ kNm}$ 

B.M. diagram is shown in Fig. 14.6 (b).

Now construct the conjugate beam as shown in Fig. 14.6 (c) by dividing B.M. at any section by their product of  $E$  and  $I$ . For the portion AB corresponding conjugate beam is  $A^*B^*C^*$ , for the portion BC corresponding conjugate beam is  $B^*C^*H^*K^*$  and for the portion CD the corresponding conjugate beam is  $C^*D^*F^*$ . The loading are shown in Fig. 14.6 (c).

$$\text{The ordinates } B^*E^* = \frac{2000}{EI}, \quad B^*K^* = \frac{2000}{3EI}$$

$$C^*F^* = \frac{2500}{2EI}, \quad C^*H^* = \frac{2500}{3EI}$$

$$H^*J^* = \frac{2500}{3EI} - \frac{2000}{3EI} = \frac{500}{3EI}$$

Let  $R_A^*$  = Reaction at  $A^*$  for conjugate beam

$R_D^*$  = Reaction at  $D^*$  for conjugate beam.

To find  $R_A^*$  and  $R_D^*$ , take the moments of all loads acting on the conjugate beam about  $A^*$ , we get

$$\begin{aligned} R_D^* \times 30 &= \left(\frac{1}{2} \times A^*B^* \times B^*E^*\right) \times \left(\frac{2}{3} \times A^*B^*\right) + (B^*C^* \times B^*K^*) \\ &\quad \times \left(10 + \frac{10}{2}\right) + \left(\frac{1}{2} \times K^*J^* \times H^*J^*\right) \times \left(10 + 10 \times \frac{2}{3}\right) \\ &\quad + \left(\frac{1}{2} \times C^*F^* \times C^*D^*\right) \times \left(20 + 10 \times \frac{1}{3}\right) \\ &= \left(\frac{1}{2} \times 10 \times \frac{2000}{EI}\right) \times \left(\frac{2}{3} \times 10\right) + \left(10 \times \frac{2000}{3EI}\right) \times (15) \\ &\quad + \left(\frac{1}{2} \times 10 \times \frac{500}{3EI}\right) \times \left(\frac{50}{3}\right) + \left(\frac{1}{2} \times \frac{2500}{2EI} \times 10\right) \times \left(\frac{70}{3}\right) \\ &= \frac{200000}{3EI} + \frac{300000}{3EI} + \frac{125000}{9EI} + \frac{437500}{3EI} \\ &= \frac{600000 + 900000 + 125000 + 1312500}{9EI} = \frac{2937500}{9EI} \end{aligned}$$

$$R_D^* = \frac{2937500}{9EI \times 30} = \frac{293750}{27EI}$$

$R_A^*$  = Total load on conjugate beam -  $R_D^*$

$$\begin{aligned} &= \left(\frac{1}{2} \times 10 \times \frac{2000}{EI} + 10 \times \frac{2000}{3EI} + \frac{1}{2} \times 10 \times \frac{500}{3EI} + \frac{1}{2} \times 10 \times \frac{2500}{2EI}\right) \\ &\quad - \frac{293750}{27EI} \\ &= \left(\frac{10000}{EI} + \frac{20000}{3EI} + \frac{2500}{3EI} + \frac{6250}{EI}\right) - \frac{293750}{27EI} \\ &= \left(\frac{30000 + 20000 + 2500 + 18750}{3EI}\right) - \frac{293750}{27EI} \\ &= \frac{71250}{3EI} - \frac{293750}{27EI} = \frac{641250 - 293750}{27EI} = \frac{347500}{27EI} \end{aligned}$$

(i) Slopes at A, B, C and D

According to conjugate beam method

(a) Slope at A for the given beam

= S.F. at  $A^*$  for conjugate beam

$$\theta_A = R_A^* = \frac{347500}{27EI} = \frac{347500}{27 \times 2 \times 10^8 \times 2 \times 10^{-2}} = 0.003218 \text{ rad. Ans.}$$

(b) Slope at B for the given beam

= S.F. at  $B^*$  for conjugate beam

=  $R_A^*$  - Load  $A^*B^*E^*$

$$\begin{aligned} &= \frac{347500}{27EI} - \frac{1}{2} \times 10 \times \frac{2000}{EI} \\ &= \frac{347500}{27EI} - \frac{10000}{EI} = \frac{347500 - 270000}{27EI} \end{aligned}$$

$$\begin{aligned} &= \frac{77500}{27EI} = \frac{77500}{27 \times 2 \times 10^8 \times 2 \times 10^{-2}} \\ &= 0.0007176 \text{ radians. Ans.} \end{aligned}$$

(c) Slope at C for the given beam

= S.F. at  $C^*$  for conjugate beam

=  $R_D^*$  - Load  $D^*C^*F^*$

$$\begin{aligned} &= \frac{293750}{27EI} - \frac{1}{2} \times 10 \times \frac{2500}{2EI} \\ &= \frac{293750}{27EI} - \frac{6250}{EI} = \frac{293750 - 27 \times 6250}{27EI} = \frac{125000}{27EI} \\ &= \frac{125000}{27 \times 2 \times 10^8 \times 2 \times 10^{-2}} = 0.001157 \text{ rad. Ans.} \end{aligned}$$

(d) Slope at D for the given beam

= S.F. at  $D^*$  for conjugate beam

$$= R_D^* = \frac{293750}{27EI}$$

$$= \frac{293750}{27 \times 2 \times 10^8 \times 2 \times 10^{-2}} = 0.00272 \text{ rad. Ans.}$$

(ii) Deflection at A, B, C and D

(a) Deflection at A for the given beam

= B.M. at  $A^*$  for the conjugate beam

= 0. Ans.

(b) Deflection at B for the given beam

= B.M. at  $B^*$  for the conjugate beam

=  $R_A^* \times 10$  - Load  $A^*B^*E^* \times$  Distance of C.G. of  $A^*B^*E^*$  from  $B^*$

$$\begin{aligned} &= \frac{347500}{27EI} \times 10 - \left(\frac{1}{2} \times 10 \times \frac{2000}{EI}\right) \times \frac{10}{3} \\ &= \frac{3475000}{27EI} - \frac{100000}{3EI} \\ &= \frac{3475000 - 900000}{27EI} = \frac{2575000}{27EI} \\ &= \frac{2575000}{27 \times 2 \times 10^8 \times 2 \times 10^{-2}} = 0.02384 \text{ m} \\ &= 23.84 \text{ mm. Ans.} \end{aligned}$$

(c) Deflection at C for the given beam

= B.M. at  $C^*$  for the conjugate beam

=  $R_D^* \times 10$  - Load  $D^*C^*F^* \times$  Distance of C.G. of  $D^*C^*F^*$  from  $C^*$

$$\begin{aligned} &= \frac{293750}{27EI} \times 10 - \frac{1}{2} \times 10 \times \frac{2500}{2EI} \times \frac{10}{3} \\ &= \frac{2937500}{27EI} - \frac{62500}{3EI} = \frac{2937500 - 62500 \times 9}{27EI} \end{aligned}$$

$$= \frac{2375000}{27EI} = \frac{2375000}{27 \times 2 \times 10^8 \times 2 \times 10^{-2}} = 0.02199 \text{ m}$$

$$= 21.99 \text{ mm. Ans.}$$

(d) Deflection of  $D$  for the given beam = 0. Ans.

#### 14.5. RELATION BETWEEN ACTUAL BEAM AND CONJUGATE BEAM

The relations between an actual beam and the corresponding conjugate beam for different end conditions are given in Table 14.1.

TABLE 14.1

S. No.	Actual beam	Conjugate beam
1.	Simply supported or roller supported end (Deflection = 0 but slope exists)	Simply supported end B.M. = 0 but S.F. exists
2.	Free end (slope and deflection exist)	Fixed end (S.F. and B.M. exist)
3.	Fixed end (slope and deflection are zero)	Free end (S.F. and B.M. are zero)
4.	Slope at any section	S.F. at the corresponding section
5.	Deflection at any section	B.M. at the corresponding section
6.	Given system of loading	The loading diagram is $M/EI$ diagram
7.	B.M. diagram positive (sagging)	$M/EI$ load diagram is positive (i.e., loading is downward)
8.	B.M. diagram negative (hogging)	$M/EI$ load diagram is negative (i.e., loading is upward)

#### 14.6. DEFLECTION AND SLOPE OF A CANTILEVER WITH A POINT LOAD AT THE FREE END

Fig. 14.7 (a) shows a cantilever  $AB$  of length  $L$  and carrying a point load  $W$  at the free end  $B$ . The B.M. is zero at the free end  $B$  and B.M. at  $A$  is equal to  $W.L$ . The B.M. diagram is shown in Fig. 14.7 (b). The conjugate beam can be drawn by dividing the B.M. at any section by  $EI$ . Fig. 14.7 (c) shows the conjugate beam  $A^*B^*$  (free at  $A^*$  and fixed at  $B^*$ ). The loading on the conjugate beam will be negative (i.e., upwards) as B.M. for cantilever is negative. The loading on conjugate beam is shown in Fig. 14.7 (c).

Let  $\theta_B$  = Slope at  $B$  i.e.,  $\left(\frac{dy}{dx}\right)$  at  $B$  for the given cantilever and

$y_B$  = Deflection at  $B$  for the given cantilever.

Then according to the conjugate beam method,

$$\theta_B = \text{S.F. at } B^* \text{ for the conjugate beam}$$

$$= \text{Load } B^*A^*C^*$$

$$= \frac{1}{2} \times A^*B^* \times A^*C^* = \frac{1}{2} \times L \times \frac{W \cdot L}{EI} = \frac{W \cdot L^2}{2EI}$$

and

$$y_B = \text{B.M. at } B^* \text{ for the conjugate beam}$$

$$= \text{Load } B^*A^*C^* \times \text{Distance of C.G. of } B^*A^*C^* \text{ from } B^*$$

$$= \left(\frac{1}{2} \cdot L \cdot \frac{WL}{EI}\right) \times \left(\frac{2}{3} \times L\right) = \frac{WL^3}{3EI}$$

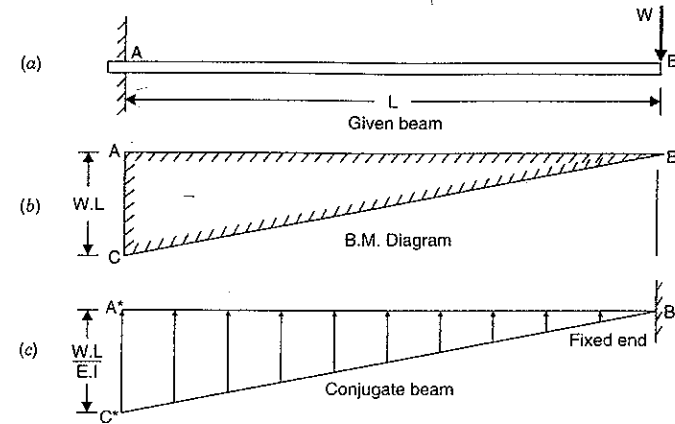

Fig. 14.7

**Problem 14.5.** A cantilever of length 3 m carries a point load of 10 kN at a distance of 2 m from the fixed end. If  $E = 2 \times 10^5 \text{ N/mm}^2$  and  $I = 10^8 \text{ mm}^4$ , find the slope and deflection at the free end using conjugate beam method.

**Sol.** Given :

Length,  $L = 3 \text{ m}$

Point load,  $W = 10 \text{ kN}$

Distance  $AC = 2 \text{ m}$

Value of  $E = 2 \times 10^5 \text{ N/mm}^2$

$$= 2 \times 10^5 \times 10^6 \text{ N/m}^2 = 2 \times 10^8 \text{ kN/m}^2$$

Value of  $I = 10^8 \text{ mm}^4$

$$= 10^8 \times \frac{1}{10^{12}} \text{ m}^4 = 10^{-4} \text{ m}^4$$

B.M. at  $B = 0$

B.M. at  $C = 0$

B.M. at  $A = -10 \times 2 = -20 \text{ kNm}$

Now B.M. can be drawn as shown in Fig. 14.8 (b). Now construct conjugate beam  $A^*B^*$  (free at  $A^*$  and fixed at  $B^*$ ) by dividing the B.M. at any section by  $EI$ , as shown in Fig. 14.8 (c). The loading on the conjugate beam will be negative (i.e., acting upwards) as B.M. is negative.

Let  $\theta_B$  = Slope at the free end for the given cantilever i.e.,  $\left(\frac{dy}{dx}\right)$  at  $B$  and

$y_B$  = Deflection at  $B$  for the given cantilever.

Then according to the conjugate beam method,

$$\theta_B = \text{S.F. at } B^* \text{ for conjugate beam}$$

$$= \text{Load } A^*C^*D^* = \frac{1}{2} \times A^*C^* \times A^*D^*$$



$$= \frac{1}{2} \times 2 \times \frac{20}{EI} = \frac{20}{EI}$$

$$= \frac{20}{2 \times 10^8 \times 10^{-4}} = 0.001 \text{ rad. Ans.}$$

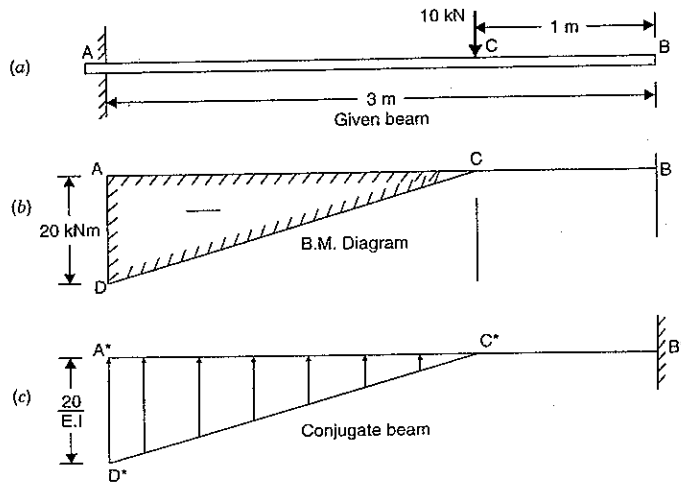

Fig. 14.8

and

$$y_B = \text{B.M. at } B^* \text{ for the conjugate beam}$$

$$= (\text{Load } A^*C^*D^*) \times \text{Distance of C.G. of } A^*C^*D^* \text{ from } B^*$$

$$= \left( \frac{1}{2} \times 2 \times \frac{20}{EI} \right) \times \left( 1 + \frac{2}{3} \times 2 \right)$$

$$= \frac{20}{EI} \times \frac{7}{3} = \frac{20}{2 \times 10^8 \times 10^{-4}} \times \frac{7}{3}$$

$$= 0.00233 \text{ m} = 2.33 \text{ mm. Ans.}$$

**Problem 14.6.** A cantilever beam AB of length 2 m is carrying a point load 10 kN at B. The moment of inertia for the right half of the cantilever is  $10^8 \text{ mm}^4$  whereas that for the left half is  $2 \times 10^8 \text{ mm}^4$ . If  $E = 2 \times 10^8 \text{ kN/m}^2$ , find the slope and deflection at the free end of the cantilever.

**Sol. Given :**

Length,  $L = 2 \text{ m}$

Point load,  $W = 10 \text{ kN}$

Length,  $AC = \text{length } BC = 1 \text{ m}$

M.O.I. of length BC,  $I = 10^8 \text{ mm}^4 = 10^{-4} \text{ m}^4$

M.O.I. of length AC  $= 2 \times 10^8 \text{ mm}^4 = 2 \times 10^{-4} \text{ m}^4 = 2I$

Value of  $E = 2 \times 10^8 \text{ kN/m}^2$

B.M. at B = 0

B.M. at C =  $-10 \times 1 = -10 \text{ kNm}$

B.M. at A =  $-10 \times 2 = -20 \text{ kNm}$ .

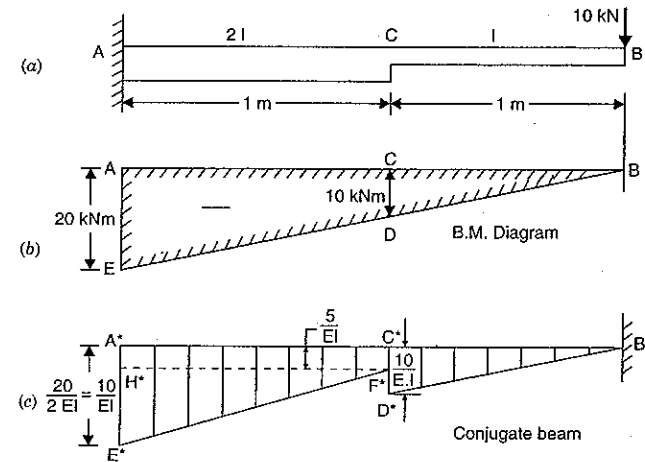

Fig. 14.9

Now B.M. diagram can be drawn as shown in Fig. 14.9 (b). Now construct conjugate beam  $A^*B^*$  (free at  $A^*$  and fixed at  $B^*$ ) by dividing the B.M. at any section by their  $EI$  factor. The loading diagram will be as shown in Fig. 14.9 (c) in which,

$$A^*E^* = \frac{\text{B.M. at A}}{E \times (\text{M.O.I. of AC})} = \frac{20}{E \times 2I} = \frac{10}{EI}$$

$$C^*E^* = \frac{\text{B.M. at C}}{E \times (\text{M.O.I. of AC})} = \frac{10}{E \times 2I} = \frac{5}{EI}$$

$$C^*D^* = \frac{\text{B.M. at C}}{E \times (\text{M.O.I. of BC})} = \frac{10}{E \times I} = \frac{10}{EI}$$

Let  $\theta_B = \text{Slope at } B \text{ i.e., } \left( \frac{dy}{dx} \right) \text{ at } B \text{ for the given cantilever}$

$y_B = \text{Deflection at } B \text{ for the given cantilever.}$

Then according to conjugate beam method,

$$\theta_B = \text{S.F. at } B^* \text{ for conjugate beam}$$

$$= \text{Load } A^*C^*F^*E^* + \text{Load } B^*C^*D^*$$

$$= \frac{1}{2} (A^*E^* + C^*F^*) \times A^*C^* + \frac{1}{2} B^*C^* \times C^*D^*$$

$$= \frac{1}{2} \left( \frac{10}{EI} + \frac{5}{EI} \right) \times 1 + \frac{1}{2} \times 1 \times \frac{10}{EI}$$

$$= \frac{15}{2EI} + \frac{10}{2EI} = \frac{25}{2EI}$$

$$= \frac{25}{2 \times 2 \times 10^8 \times 10^{-4}} = 0.000625 \text{ rad. Ans.}$$

and

$$\begin{aligned}
 y_B &= \text{B.M. at } B^* \text{ for the conjugate beam} \\
 &= \text{Load } A^*C^*F^*H^* \times \text{Distance of its C.G. from } B^* \\
 &\quad + \text{Load } H^*E^*F^* \times \text{Distance of its C.G. from } B^* \\
 &\quad + \text{Load } A^*C^*D^* \times \text{Distance of its C.G. from } B^* \\
 &= \left(1 \times \frac{5}{EI}\right) \times 1.5 + \left(\frac{1}{2} \times 1 \times \frac{5}{EI}\right) \times \left(1 + \frac{2}{3} \times 1\right) + \left(\frac{1}{2} \times 1 \times \frac{10}{EI}\right) \times \left(\frac{2}{3} \times 1\right) \\
 &= \frac{7.5}{EI} + \frac{25}{6EI} + \frac{10}{3EI} = \frac{45 + 25 + 20}{6EI} \\
 &= \frac{90}{6EI} = \frac{15}{EI} = \frac{15}{2 \times 10^8 \times 10^{-4}} \text{ m} \\
 &= 0.00075 \text{ m} = \mathbf{0.75 \text{ mm. Ans.}}
 \end{aligned}$$

**Problem 14.7.** A cantilever of length 3 m carries a uniformly distributed load of 80 kN/m length over the entire length. If  $E = 2 \times 10^8 \text{ kN/m}^2$  and  $I = 10^8 \text{ mm}^4$ , find the slope and deflection at the free end using conjugate beam method.

**Sol. Given :**

$$\begin{aligned}
 \text{Length,} & L = 3 \text{ m} \\
 \text{U.d.l.,} & w = 80 \text{ kN/m} \\
 \text{Value of} & E = 2 \times 10^8 \text{ kN/m}^2
 \end{aligned}$$

$$\text{Value of } I = 10^8 \text{ mm}^4 = \frac{10^8}{10^{12}} \text{ m}^4 = 10^{-4} \text{ m}^4$$

$$\text{B.M. at } B = 0$$

$$\text{B.M. at } A = -(wL) \cdot \frac{L}{2} = -80 \times 3 \times \frac{3}{2} = -360 \text{ kNm}$$

The variation of B.M. between A and B is parabolic as shown in Fig. 14.10 (b).

Now construct conjugate beam  $A^*B^*$  (free at  $A^*$  and fixed at  $B^*$ ) by dividing the B.M. at any section by  $EI$ . The loading diagram will be as shown in Fig. 14.10 (c).

Let  $\theta_B$  = Slope at B for the given cantilever and

$y_B$  = Deflection at B for the given cantilever.

Then according to conjugate beam method,

$$\begin{aligned}
 \theta_B &= \text{S.F. at } B^* \text{ for conjugate beam} \\
 &= \text{Load } B^*A^*C^* \text{ or Area of } B^*A^*C^* \\
 &= \frac{1}{3} \text{ of the rectangle containing parabola} \\
 &= \frac{1}{3} \times (A^*B^* \times A^*C^*) \\
 &= \frac{1}{3} \times 3 \times \frac{360}{EI} \\
 &= \frac{360}{EI} = \frac{360}{2 \times 10^8 \times 10^{-4}} \\
 &= \mathbf{0.008 \text{ rad. Ans.}}
 \end{aligned}$$

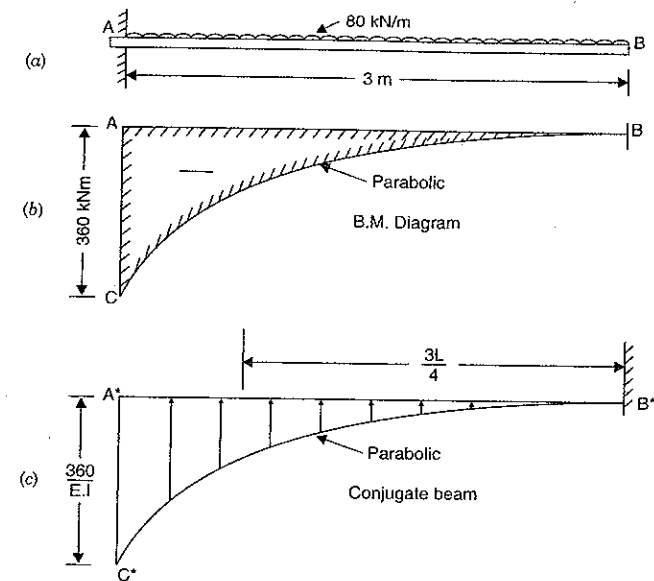

Fig. 14.10

and

$$\begin{aligned}
 y_B &= \text{B.M. at } B^* \text{ for conjugate beam} \\
 &= \text{Load } A^*C^*B^* \times \text{Distance of its C.G. from } B^* \\
 &= \left(\frac{1}{3} \times 3 \times \frac{360}{EI}\right) \times \frac{3L}{4} = \frac{360}{EI} \times \frac{3 \times 3}{4} = \frac{810}{EI} \\
 &= \frac{810}{2 \times 10^8 \times 10^{-4}} = 0.0405 \text{ m} = \mathbf{40.5 \text{ mm. Ans.}}
 \end{aligned}$$

#### 14.7. PROPPED CANTILEVERS AND BEAMS

When a cantilever or a beam carries some load, maximum deflection occurs at the free end in case of cantilever and at the middle point in case of simply supported beam. The deflection can be reduced by providing vertical support at these points or at any suitable point. Propped cantilevers means cantilevers supported on a vertical support at a suitable point. The vertical support is known as prop. The props which does not yield under the loads is known as rigid. The prop (or support) which is of the same height as the original position of the (unloaded) cantilever or beam, does not allow any deflection at the point of support (or prop) when the cantilever or beam is loaded. The prop exerts an upward force on the cantilever or beam. As the deflection at the point of prop is zero, hence the upward force of the prop is such a magnitude as to give an upward deflection at the point of prop equal to the deflection (at the point of prop) due to the load on the beam when there is no prop.

Hence the reaction of the prop (or the upward force of the prop) is calculated by equating the downward deflection due to load at the point of prop to the upward deflection due to prop reaction.

#### 14.8. S.F. AND B.M. DIAGRAMS FOR A PROPPED CANTILEVER CARRYING A POINT LOAD AT THE CENTRE AND PROPPED AT THE FREE END

Fig. 14.11 (a) shows a cantilever  $AB$  of length  $L$  fixed at  $A$  and supported on a prop at  $B$  carrying a point load  $W$  at the centre.

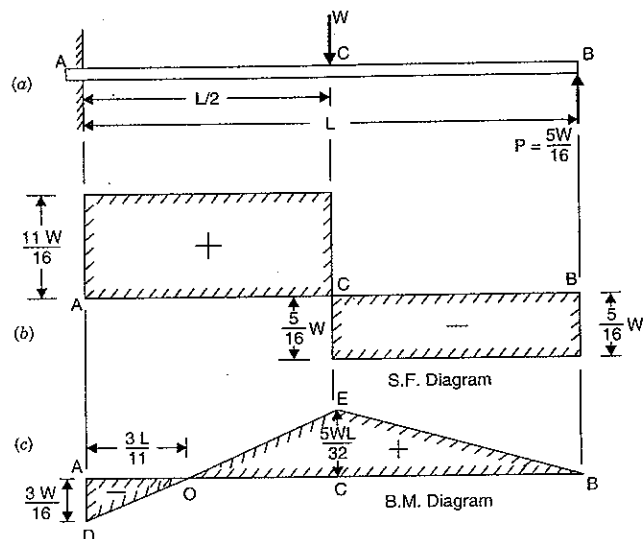

Fig. 14.11

Let  $P$  = Reaction at the rigid prop.

To find the reaction  $P$  at the prop\*, the downward deflection due to  $W$  at the point of prop should be equal to the upward deflection due to prop reaction at  $B$ .

Now we know that downward deflection at point  $B$  due to load  $W$

$$\begin{aligned} &= \frac{W \left(\frac{L}{2}\right)^3}{3EI} + \frac{W \left(\frac{L}{2}\right)^2}{2EI} \times \left(\frac{L}{2}\right) \quad \text{(See equation 13.4)} \\ &= \frac{WL^3}{24EI} + \frac{WL^3}{16EI} \\ &= \frac{2WL^3 + 3WL^3}{48EI} = \frac{5WL^3}{48EI} \quad \dots(i) \end{aligned}$$

The upward deflection at the point  $B$  due to prop reaction  $P$  alone

$$= \frac{PL^3}{3EI} \quad \dots(ii)$$

\*Never calculate  $P$  by equating the clockwise moment due to the load  $W$  to the anticlockwise moment due to  $P$  at the fixed end, as at the fixed end there exist a fixing moment.

Equating equations (i) and (ii), we get

$$\frac{PL^3}{3EI} = \frac{5WL^3}{48EI}$$

$$\therefore P = \frac{5}{16} W \quad \dots(14.1)$$

(i) S.F. Diagrams

$$\begin{aligned} \text{S.F. at } B &= -P \\ &= -\frac{5W}{16} \end{aligned} \quad \text{(Minus sign due to right upwards)}$$

The S.F. will remain constant between  $B$  and  $C$  and equal to  $(-) \frac{5W}{16}$

$$\text{S.F. at } C = -\frac{5W}{16} + W = +\frac{11W}{16}$$

The S.F. will remain  $+\frac{11W}{16}$  between  $C$  and  $A$ .

The S.F. diagram is shown in Fig. 14.11 (b).

(ii) B.M. Diagram

$$\begin{aligned} \text{B.M. at } B &= 0 \\ \text{B.M. at } C &= \frac{5W}{16} \times \frac{L}{2} = \frac{5WL}{32} \\ \text{B.M. at } A &= \frac{5W}{16} \times L - \frac{W \cdot L}{2} \\ &= \frac{5WL - 8WL}{16} = -\frac{3WL}{16} \end{aligned}$$

The B.M. diagram is shown in Fig. 14.11 (c). As the B.M. is changing sign between  $C$  and  $A$ , hence there will be a point of contraflexure between  $C$  and  $A$ . To find its location, equate the B.M. between  $A$  and  $C$  to zero.

The B.M. at any section between  $C$  and  $A$  at a distance  $x$  from  $B$

$$= \frac{5W}{16} \times x - W \left(x - \frac{L}{2}\right)$$

Equating the above B.M. to zero, we get

$$\frac{5W}{16} \cdot x - W \left(x - \frac{L}{2}\right) = 0$$

$$\text{or } \frac{5x}{16} - x + \frac{L}{2} = 0$$

$$\text{or } -\frac{11}{16}x = -\frac{L}{2}$$

$$\text{or } x = \frac{16L}{11 \times 2} = \frac{8L}{11}$$

Hence the point of contraflexure will be at a distance  $8L/11$  from  $B$  or  $3L/11$  from  $A$ .

#### 14.9. S.F. AND B.M. DIAGRAM FOR A PROPPED CANTILEVER CARRYING A UNIFORMLY DISTRIBUTED LOAD AND PROPPED AT THE FREE END

Fig. 14.12 (a) shows a cantilever  $AB$  of length  $L$  fixed at  $A$  and propped at  $B$ , carrying a uniformly distributed load of  $w$ /unit length over its entire length.

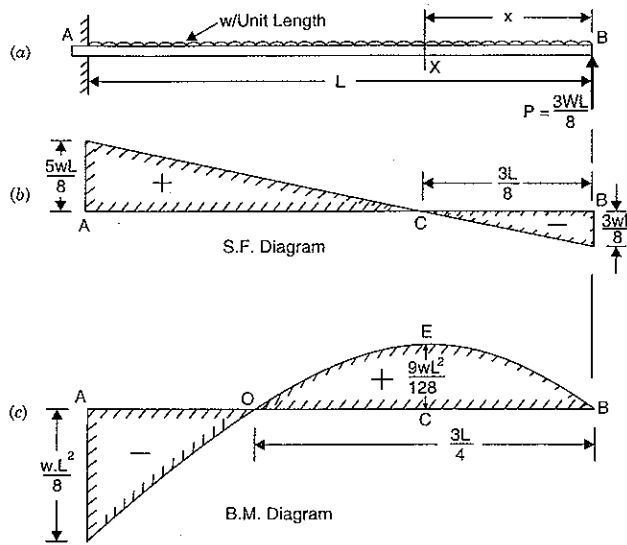

Fig. 14.12

Let  $P$  = Reaction at the prop.

To find the reaction  $P$  at the prop, the downward deflection due to uniformly distributed load at  $B$  should be equated to the upward deflection due to prop reaction at  $B$ .

We know that downward deflection at point  $B$  due to u.d.l.

$$= \frac{wL^4}{8EI} \quad \dots(i) \quad (\text{See equation 13.6})$$

The upward deflection at point  $B$  due to prop reaction  $P$  alone

$$= \frac{PL^3}{3EI} \quad \dots(ii)$$

Equating equations (i) and (ii), we get

$$\frac{PL^3}{3EI} = \frac{w \cdot L^4}{8EI}$$

$$\therefore P = \frac{3}{8} w \cdot L \quad \dots(14.2)$$

(i) S.F. diagram

S.F. at  $B = -P$  (Minus sign due to right upwards)

$$= -\frac{3}{8} wL$$

The S.F. at any section at a distance  $x$  from  $B$  is given by

$$F_x = -\frac{3}{8} w \cdot L + w \cdot x \quad \dots(iii)$$

The S.F. varies by a straight line law between  $A$  and  $B$ . S.F. at  $A$  is obtained by substituting  $x = L$  in the above equation.

$$F_A = -\frac{3}{8} wL + w \cdot L = +\frac{5}{8} w \cdot L$$

To find the point, at which S.F. is zero, equation (iii) should be equated to zero.

$$0 = -\frac{3wL}{8} + wx \quad \text{or} \quad x = \frac{3L}{8}$$

Hence the S.F. is zero at a distance  $3L/8$  from  $B$ . The point of zero shear is shown by  $C$ . The S.F. diagram is shown in Fig. 14.12 (b).

(ii) B.M. diagram

B.M. at  $B = 0$

B.M. at any section at a distance  $x$  from  $B$  is given by,

$$M_x = \frac{3}{8} w \cdot L \cdot x - w \cdot x \cdot \frac{x}{2} \quad \dots(iv)$$

At  $A$ ,  $x = L$  and hence B.M. at  $A$  is given by,

$$M_A = \frac{3}{8} w \cdot L \cdot L - w \cdot L \cdot \frac{L}{2}$$

$$= \frac{3}{8} w \cdot L^2 - \frac{1}{2} w \cdot L^2$$

$$= \frac{(3-4)w \cdot L^2}{8} = -\frac{w \cdot L^2}{8}$$

The S.F. is zero at  $x = \frac{3L}{8}$ , hence B.M. at the point of zero shear is obtained by substituting

$x = \frac{3L}{8}$  in equation (iv). Hence B.M. at  $C$  is given by

$$M_C = \frac{3}{8} w \cdot L \cdot \frac{3L}{8} - w \cdot \frac{3L}{8} \cdot \frac{3L}{8 \times 2}$$

$$= \frac{9wL^2}{64} - \frac{9w \cdot L^2}{128} = \frac{9}{128} w \cdot L^2$$

The B.M. diagram is shown in Fig. 14.12 (c).

(iii) Point of contraflexure

Putting  $M_x = 0$  in equation (iv), we get

$$0 = \frac{3}{8} w \cdot L \cdot x - w \cdot x \cdot \frac{x}{2}$$

or

$$0 = \frac{3}{8} L - \frac{x}{2} \quad (\text{Cancelling } wx)$$

or

$$x = \frac{3 \times 2L}{8} = \frac{3L}{4}$$

(iv) Deflection

The B.M. at any section at a distance  $x$  from  $B$  is given by equation (iv).

$$\therefore M_x = \frac{3}{8} w \cdot L \cdot x - \frac{wx^2}{2}$$

But B.M. at any section is also equal to  $EI \frac{d^2y}{dx^2}$

$$\therefore EI \frac{d^2 y}{dx^2} = \frac{3}{8} w \cdot L \cdot x - \frac{wx^2}{2}$$

Integrating the above equation, we get

$$EI \frac{dy}{dx} = \frac{3w \cdot L \cdot x^2}{8 \times 2} - \frac{w}{2} \cdot \frac{x^3}{3} + C_1$$

$$= \frac{3}{16} w \cdot L \cdot x^2 - \frac{w}{6} \cdot x^3 + C_1 \quad \dots(v)$$

Integrating again, we get

$$EIy = \frac{3}{16} w \cdot L \cdot \frac{x^2}{3} - \frac{w}{6} \cdot \frac{x^4}{4} + C_1 x + C_2$$

$$= \frac{w \cdot L \cdot x^3}{16} - \frac{w}{24} \cdot x^4 + C_1 x + C_2 \quad \dots(vi)$$

where  $C_1$  and  $C_2$  are constant of integration. At the fixed end the slope and deflection are zero. At the end B, deflection is zero. Hence at B,  $x = 0$  and  $y = 0$ .

Substituting  $x = 0$  and  $y = 0$  in equation (vi), we get

$$0 = C_2$$

Substituting  $x = L$  and  $y = 0$  in equation (vi), we get

$$0 = \frac{w \cdot L \cdot L^3}{16} - \frac{w}{24} \cdot L^4 + C_1 \cdot L + 0 \quad (\because C_2 = 0)$$

$$= \frac{wL^3}{16} - \frac{wL^3}{24} + C_1$$

or

$$C_1 = \frac{wL^3}{24} - \frac{wL^3}{16} = \frac{2wL^3 - 3wL^3}{48} = -\frac{wL^3}{48}$$

Substituting the values of  $C_1$  and  $C_2$  in equation (vi), we get

$$EIy = \frac{w \cdot L \cdot x^3}{16} - \frac{w}{24} \cdot x^4 - \frac{wL^3}{48} \cdot x \quad \dots(vii)$$

The above equation gives the deflection at any section of the cantilever.

The deflection at the centre of the cantilever is obtained by substituting  $x = \frac{L}{2}$  in equation (vii). If  $y_c$  is the deflection at the centre then, we have

$$EI \cdot y_c = \frac{wL}{16} \times \left(\frac{L}{2}\right)^3 - \frac{w}{24} \left(\frac{L}{2}\right)^4 - \frac{wL^3}{48} \cdot \frac{L}{2}$$

$$= \frac{wL^4}{16 \times 8} - \frac{wL^4}{24 \times 16} - \frac{wL^4}{96}$$

$$= \frac{3wL^4 - wL^4 - 4wL^4}{24 \times 16} = -\frac{2wL^4}{24 \times 16} = -\frac{wL^4}{192}$$

$$\therefore y_c = -\frac{wL^4}{192EI} \quad (\text{Negative sign means that deflection is downwards})$$

\(\therefore\) Downward deflection,

$$y_c = \frac{wL^4}{192EI} \quad \dots(14.3)$$

(v) Maximum deflection

Maximum deflection takes place where  $\frac{dy}{dx}$  is zero. Differentiating equation (vii) w.r.t.  $x$ , we get

$$EI \frac{dy}{dx} = \frac{3wL}{16} x^2 - \frac{4w}{24} x^3 - \frac{wL^3}{48}$$

$$= \frac{3w \cdot L}{16} x^2 - \frac{w}{6} x^3 - \frac{w \cdot L^3}{48}$$

Putting,  $\frac{dy}{dx} = 0$ , we get

$$0 = \frac{3}{16} w \cdot L \cdot x^2 - \frac{wx^3}{6} - \frac{w \cdot L^3}{48}$$

$$0 = 9w \cdot L \cdot x^2 - 8w \cdot x^3 - wL^3$$

The above equation is solved by trial and error. Hence we get

$$x = 0.422L \quad \dots(14.4)$$

Substituting this value in equation (vii), we get maximum deflection.

$$\therefore EIy_{max} = \frac{wL}{16} \times (.422L)^3 - \frac{w}{24} (.422L)^4 - \frac{wL^3}{48} \times (.422L)$$

$$= -0.005415wL^4$$

$$\therefore y_{max} = \frac{0.005415w \cdot L^4}{EI}$$

\(\therefore\) Maximum downward deflection

$$= \frac{0.005415}{EI} w \cdot L^4 \quad \dots(14.5)$$

**Problem 14.8.** A cantilever of length 6 m carries a point load of 48 kN at its centre. The cantilever is propped rigidly at the free end. Determine the reaction at the rigid prop.

**Sol.** Given :

Length,  $L = 6$  m

Point load,  $W = 48$  kN

Let  $P =$  Reaction at the rigid prop

Using equation (14.1), we get

$$P = \frac{5}{16} \times W$$

$$= \frac{5}{16} \times 48 = 15 \text{ kN. Ans.}$$

**Problem 14.9.** A cantilever of length 4 m carries a uniformly distributed load of 1 kN/m run over the whole length. The cantilever is propped rigidly at the free end. If the value of  $E = 2 \times 10^5$  N/mm<sup>2</sup> and  $I$  of the cantilever =  $10^8$  mm<sup>4</sup>, then determine :

(i) Reaction at the rigid prop,

(ii) The deflection at the centre of the cantilever,

(iii) Magnitude and position of maximum deflection.

**Sol.** Given :

Length,  $L = 4$  m

U.d.l.	$w = 1 \text{ kN/m run}$
Value of	$E = 2 \times 10^5 \text{ N/mm}^2 = 2 \times 10^5 \times 10^6 \text{ N/m}^2$ $= 2 \times 10^{11} \text{ N/m}^2$
Value of	$I = 10^8 \text{ mm}^4 = 10^8 \times 10^{-12} \text{ m}^4 = 10^{-4} \text{ m}^4$

(i) Reaction at the rigid prop

Let  $P =$  Reaction at the rigid prop

Using equation (14.2), we get

$$P = \frac{3}{8} \times w \cdot L$$

$$= \frac{3}{8} \times 1 \times 4 = 1.5 \text{ kN. Ans.}$$

(ii) The deflection at the centre of the cantilever

Let  $y_C =$  Deflection at the centre of cantilever

Using equation (14.3), we get

$$y_C = \frac{wL^4}{192EI}$$

$$= \frac{1000 \times 4^4}{192 \times 2 \times 10^{11} \times 10^{-4}} \text{ m} \quad (\because w = 1 \text{ kN} = 1000 \text{ N})$$

$$= \frac{256}{384 \times 10^4} \text{ m} = \frac{2}{3} \times \frac{1000}{10^4} \text{ mm}$$

$$= 0.0667 \text{ mm. Ans.}$$

(iii) Magnitude and position of maximum deflection

The position of the maximum deflection is given by equation (14.4).

$$\therefore x = 0.422 \times L$$

$$= 0.422 \times 4 = 1.688 \text{ m.}$$

Hence maximum deflection will be at a distance 1.688 m from the free end of the cantilever.

Maximum deflection is given by equation (14.5)

$$\therefore y_{max} = \frac{0.005415w \cdot L^4}{EI}$$

$$= \frac{0.005415 \times 1000 \times 4^4}{2 \times 10^{11} \times 10^{-4}} \text{ m} \quad (\because w = 1 \text{ kN} = 1000 \text{ N})$$

$$= \frac{0.005415 \times 1000 \times 256 \times 1000}{2 \times 10^7} \text{ mm}$$

$$= 0.0693 \text{ mm. Ans.}$$

**Problem 14.10.** A cantilever ABC is fixed at A and rigidly propped at C and is loaded as shown in Fig. 14.13. Find the reaction at C.

**Sol.** Given :

Length,	$L = 6 \text{ m}$
U.d.l.,	$w = 1 \text{ kN/m}$
Loaded length,	$L_1 = 4 \text{ m}$
Let	$P =$ Reaction at the prop C.

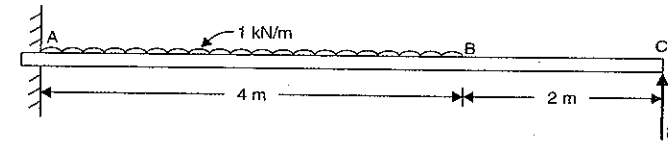

Fig. 14.13

To find the reaction  $P$  at the prop, the downward deflection due to uniformly distributed load on the  $AB$  at point  $C$  should be equated to the upward deflection due to prop reaction at  $C$ .

We know that downward deflection at point  $C$  due to u.d.l. on length  $AB$  is given by,

$$y = \frac{wL_1^4}{8EI} + \frac{wL_1^3}{6EI} (L - L_1)$$

$$= \frac{1 \times 4^4}{8EI} + \frac{1 \times 4^3}{6EI} (6 - 4) = \frac{32}{EI} + \frac{64}{3EI}$$

$$= \frac{96 + 64}{3EI} = \frac{160}{3EI} \quad \dots(i)$$

The upward deflection at point  $C$  due to prop reaction  $P$  alone

$$= \frac{PL^3}{3EI} = \frac{P \times 6^3}{3EI} = \frac{72P}{EI} \quad \dots(ii)$$

Since both the deflections given by equations (i) and (ii) should be equal.

$$\therefore \frac{160}{3EI} = \frac{72P}{EI}$$

or

$$P = \frac{160}{3 \times 72} = 0.741 \text{ kN. Ans.}$$

#### 14.10. S.F. AND B.M. DIAGRAMS FOR A SIMPLY SUPPORTED BEAM WITH A UNIFORMLY DISTRIBUTED LOAD AND PROPPED AT THE CENTRE

Fig. 14.14 (a) shows a simply supported beam  $AB$  of length  $L$  propped at its centre  $C$  and carrying a uniformly distributed load of  $w$ /unit length over its entire span.

Let  $P =$  Reaction of the prop at  $C$

To find the reaction  $P$  at the prop, the downward deflection at  $C$  due to uniformly distributed load should be equated to the upward deflection at  $C$  due to prop reaction.

The downward deflection at the centre of a simply supported beam due to uniformly distributed load is given by,

$$y_C = \frac{5wL^4}{384EI} \quad \dots(i)$$

The upward deflection of the beam at  $C$  due to prop reaction  $P$  alone is given by,

$$y_C = \frac{PL^3}{48EI} \quad \dots(ii)$$

Equating equations (i) and (ii), we get

$$\frac{PL^3}{48EI} = \frac{5wL^4}{384EI}$$

or

$$P = \frac{5wL^4}{384EI} \times \frac{48EI}{L^3}$$

$$= \frac{5}{8} \cdot w \cdot L = \frac{5W}{8} \quad (\because W = w \cdot L)$$

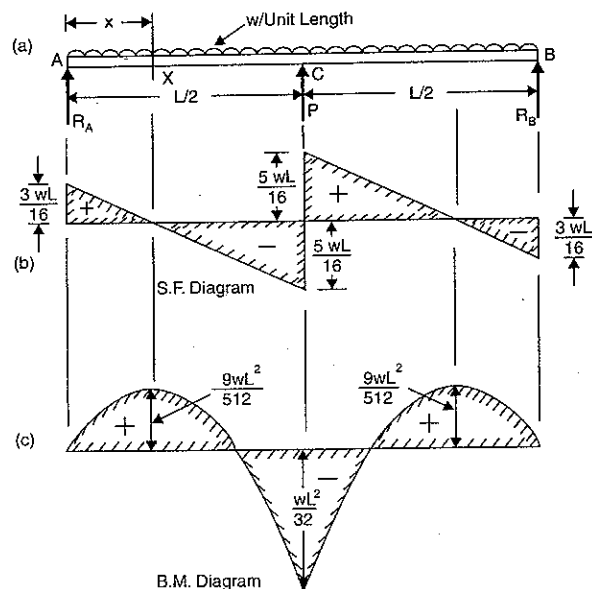

Fig. 14.14

Now reactions  $R_A$  and  $R_B$  can be calculated. Due to symmetry, the reactions  $R_A$  and  $R_B$  would be equal.

$$\text{But } R_A + R_B + P = \text{Total load on beam} = w \cdot L = W$$

$$\therefore R_A + R_A + \frac{5W}{8} = W \quad (\because R_B = R_A \text{ and } P = \frac{5W}{8})$$

or

$$R_A = \frac{1}{2} \left( W - \frac{5W}{8} \right) = \frac{1}{2} \times \frac{3W}{8} = \frac{3W}{16}$$

or

$$R_A = R_B = \frac{3W}{16}$$

(i) S.F. Diagram

$$\text{S.F. at } A = R_A = \frac{3W}{16}$$

The S.F. at any section  $X$  at a distance  $x$  from  $A$  is given by,

$$F_x = \frac{3W}{16} - wx \quad \dots(i)$$

at  $C$ ,

$$x = \frac{L}{2} \text{ and hence S.F. at } C \text{ will be,}$$

$$F_C = \frac{3W}{16} - \frac{wL}{2}$$

$$= \frac{3W}{16} - \frac{W}{2} \quad (\because W = w \cdot L)$$

$$= \frac{3W - 8W}{16} = -\frac{5W}{16}$$

Hence for the span  $AC$ , the S.F. changes uniformly from  $+\frac{3W}{16}$  at  $A$  to  $-\frac{5W}{16}$  at  $C$ .

Similarly for the span  $CB$ , the S.F. will change uniformly from  $+\frac{5W}{16}$  at  $C$  to  $-\frac{3W}{16}$  at  $B$ .

Let at a distance  $x$  from  $A$  in the span  $AC$ , the S.F. is zero. Equating S.F. as zero in equation (i), we get

$$0 = \frac{3W}{16} - w \cdot x$$

$$= \frac{3w \cdot L}{16} - w \cdot x \quad (\because W = w \cdot L)$$

$$= \frac{3L}{16} - x$$

$$\therefore x = \frac{3L}{16}$$

Hence S.F. is zero at a distance  $\frac{3L}{16}$  from  $A$ . Also S.F. will be zero at a distance  $\frac{3L}{16}$  from  $B$  due to symmetry. Now the S.F. diagram can be drawn as shown in Fig. 14.14 (b).

(ii) B.M. Diagram

B.M. at  $A$  is zero and also at  $B$  is zero.

B.M. at any section  $X$  at a distance  $x$  from  $A$  is given by,

$$M_x = R_A \cdot x - w \cdot x \cdot \frac{x}{2}$$

$$= \frac{3wL}{16} \cdot x - \frac{w \cdot x^2}{2} \quad (\because R_A = \frac{3W}{16} \text{ or } \frac{3w \cdot L}{16}) \quad \dots(ii)$$

The B.M. at  $C$  will be obtained by substituting  $x = \frac{L}{2}$  in the above equation.

$$M_C = \frac{3wL}{16} \cdot \frac{L}{2} - \frac{w \cdot \left(\frac{L}{2}\right)^2}{2}$$

$$= \frac{3w \cdot L^2}{32} - \frac{w \cdot L^2}{8} = \frac{3wL^2 - 4wL^2}{32}$$

$$= -\frac{wL^2}{32} \quad \dots(14.6)$$

Now the B.M. will be maximum where S.F. is zero after changing its sign. But S.F. is zero after changing its sign at a distance  $x = \frac{3L}{16}$  from A.

Hence by substituting  $x = \frac{3L}{16}$  in equation (ii), we get maximum B.M.

$$\begin{aligned} \therefore \text{Max. B.M.} &= \frac{3wL}{16} \cdot \frac{3L}{16} - \frac{w}{2} \cdot \left(\frac{3L}{16}\right)^2 \\ &= \frac{9wL^2}{256} - \frac{9wL^2}{2 \times 256} = \frac{18wL^2 - 9wL^2}{2 \times 256} \\ &= \frac{9wL^2}{512} \end{aligned}$$

To find the position of point of contraflexure, the B.M. must be equated to zero. Hence substituting  $M_x = 0$ , in equation (ii), we get

$$\begin{aligned} 0 &= \frac{3wL}{16} \cdot x - \frac{w}{2} \cdot x^2 \\ &= \frac{3L}{16} - \frac{x}{2} \quad \text{(Cancelling } w \cdot x \text{ to both sides)} \\ \text{or } x &= \frac{3L}{16} \times 2 = \frac{3L}{8} \end{aligned}$$

Now the B.M. diagram can be drawn as shown in Fig. 14.14 (c).

**Problem 14.11.** A uniform girder of length 8 m is subjected to a total load of 20 kN uniformly distributed over the entire length. The girder is freely supported at its ends. Calculate the B.M. and the deflection at the centre.

If a prop is introduced at the centre of the beam so as to nullify this deflection, find the net B.M. at the centre.

**Sol. Given :**

$$\begin{aligned} \text{Length,} & L = 8 \text{ m} \\ \text{Total load,} & W = 20 \text{ kN} \\ \therefore \text{U.d.l.,} & w = \frac{W}{L} = \frac{20}{8} = 2.5 \text{ kN/m.} \end{aligned}$$

(i) The deflection at the centre of a simply supported beam carrying a uniformly distributed load is given by (without prop)

$$y = \frac{5wL^4}{384EI} = \frac{5 \times 2.5 \times 8^4}{384EI} = \frac{400}{3EI} \quad \text{Ans.}$$

where  $EI$  = Stiffness of the girder.

(ii) The B.M. at the centre of a simply supported beam due to uniformly distributed load only (i.e., without prop) is given by

$$M = \frac{wL^2}{8} = \frac{2.5 \times 8^2}{8} = 20 \text{ kNm.} \quad \text{Ans.}$$

(iii) Net B.M. at the centre when a prop is introduced at the centre

Let  $M_C$  = Net B.M. at centre when a prop is provided.

Now using equation (14.6), we get

$$M_C = -\frac{wL^2}{32} = -\frac{2.5 \times 8^2}{32} = -5 \text{ kNm.} \quad \text{Ans.}$$

### 14.11. YIELDING OF A PROP

In case of a rigid prop the downward deflection due to load is equal to the upward deflection due to prop reaction. But if the prop sinks down by some amount say  $\delta$ , then downward deflection due to load is equal to the upward deflection due to prop reaction plus the amount by which the prop sinks down.

If  $y_1$  = Downward deflection of beam at the point of prop due to load,

$y_2$  = Upward deflection of the beam due to prop reaction, and

$\delta$  = Amount by which the prop sinks down

Then  $y = y_2 + \delta$  ...(14.7)

**Problem 14.12.** A cantilever of length  $L$  carries a uniformly distributed load  $w$  per unit length over the whole length. The free end of the cantilever is supported on a prop. If the prop sinks by  $\delta$ , find the prop reaction.

**Sol. Given :**

$$\begin{aligned} \text{Length} &= L \\ \text{U.d.l.} &= w \\ \text{Sinking of prop} &= \delta \end{aligned}$$

The downward deflection ( $y_1$ ) of the free end of cantilever due to uniformly distributed

load is equal to  $\frac{wL^4}{8EI}$ .

The upward deflection ( $y_2$ ) of the free end due to prop reaction  $P$  will be equal to  $\frac{PL^3}{3EI}$ .

Now using equation (14.7), we get

$$y_1 = y_2 + \delta$$

$$\frac{wL^4}{8EI} = \frac{PL^3}{3EI} + \delta$$

$$\text{or } \frac{PL^3}{3EI} = \frac{wL^4}{8EI} - \delta$$

$$\text{or } P = \frac{3EI}{L^3} \left( \frac{wL^4}{8EI} - \delta \right). \quad \text{Ans.}$$

**Problem 14.13.** A simply supported beam of span 10 m carries a uniformly distributed load of 1152 N per unit length. The beam is propped at the middle of the span. Find the amount, by which the prop should yield, in order to make all the three reactions equal.

Take  $E = 2 \times 10^5 \text{ N/mm}^2$  and  $I$  for beam =  $10^8 \text{ mm}^4$ .

**Sol. Given :**

$$\begin{aligned} \text{Span,} & L = 10 \text{ m} \\ \text{U.d.l.,} & w = 1152 \text{ N/m} \\ \text{Value of } E &= 2 \times 10^5 \text{ N/mm}^2 = 2 \times 10^5 \times 10^6 \text{ N/m}^2 \\ &= 2 \times 10^{11} \text{ N/m}^2 \end{aligned}$$

$$\text{Value of } I = 10^8 \text{ mm}^4 = 10^8 \times 10^{-12} \text{ m}^4 = 10^{-4} \text{ m}^4$$

$$\text{Total load on beam, } W = w \cdot L = 1152 \times 10 = 11520 \text{ N}$$

If all the three reactions (i.e.,  $R_A$ ,  $R_B$  and  $P$ ) are equal, then each reaction will be one third of the total load on the beam.



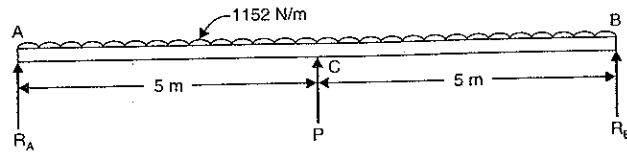

Fig. 14.15

$$\therefore R_A = R_B = P = \frac{W}{3} = \frac{11520}{3} = 3840 \text{ N.}$$

Let  $\delta$  = Amount by which the prop should yield if all the three reactions are equal.

Now the downward deflection of the beam at the centre due to uniformly distributed load alone is given by,

$$\begin{aligned} y_1 &= \frac{5wL^4}{384EI} = \frac{5}{384} \times \frac{1152 \times 10^4}{2 \times 10^{11} \times 10^{-4}} \text{ m} \\ &= \frac{7.5}{10^3} \text{ m} = \frac{7.5}{10^3} \times 10^3 \text{ mm} = 7.5 \text{ mm.} \end{aligned}$$

The upward deflection due to prop reaction at the point of prop is given by,

$$\begin{aligned} y_2 &= \frac{PL^3}{48EI} = \frac{3840 \times 10^3}{48 \times 2 \times 10^{11} \times 10^{-4}} \text{ m} \quad (\because P = 3840 \text{ N}) \\ &= \frac{40}{10^4} \text{ m} = \frac{40 \times 10^3}{10^4} \text{ mm} = 4 \text{ mm} \end{aligned}$$

Now using equation (14.7), we get

$$\begin{aligned} y_1 &= y_2 + \delta \\ \delta &= y_1 - y_2 = 7.5 - 4.0 = 3.5 \text{ mm. Ans.} \end{aligned}$$

or

### HIGHLIGHTS

1. The conjugate beam method is used to find the slope and deflections of such beams whose flexural rigidity (*i.e.*,  $EI$ ) is not uniform throughout of its length.
2. Conjugate beam is an imaginary beam of length equal to that of original beam but for which load diagram is  $M/EI$  diagram.
3. The load on conjugate beam at any point is equal to the B.M. at that point divided by  $EI$ .
4. The slope at any section of the given beam = S.F. at the corresponding section of the conjugate beam.
5. The deflection at any point of the given beam = B.M. at the corresponding point of the conjugate beam.
6. Propped cantilevers means cantilevers supported on a vertical supported at a suitable point.
7. The rigid prop does not allow any deflection at the point of prop.
8. The reaction of the prop (or the upward force of the prop) is calculated by equating the downward deflection due to load at the point of prop to the upward deflection due to prop reaction.
9. For a cantilever carrying a uniformly distributed load over the entire span and propped rigidly at the free end, we have

$$(i) \text{ Prop reaction, } P = \frac{3}{8} w.L$$

$$(ii) \text{ B.M. at fixed end, } M = \frac{w.L^2}{8}$$

$$(iii) \text{ Point of contraflexure, } x = \frac{3L}{4}$$

$$(iv) \text{ Deflection at the centre, } y_C = \frac{wL^4}{192EI}$$

$$(v) \text{ Maximum deflection, } y_{max} = \frac{0.005415wL^4}{EI}$$

where  $w$  = Uniformly distributed load,  
 $x$  = Distance from free end.

10. For a simply supported beam, carrying a uniformly distributed load over the entire span and propped at the centre, we have

$$(i) \text{ Prop reaction, } P = \frac{5}{8} W$$

$$(ii) \text{ Support reactions, } R_A = R_B = \frac{3W}{16}$$

$$(iii) \text{ B.M. at centre, } M = -\frac{wL^2}{32}$$

$$(iv) \text{ Point of contraflexure, } x = \frac{3L}{8}$$

where  $W$  = Total load on beam  
 $= w.L$

$w$  = Uniformly distributed load on beam  
 $x$  = Distance from the support.

### EXERCISE 14

#### (A) Theoretical Questions

1. Define and explain the terms : Conjugate beam, conjugate beam method, flexural rigidity and propped beam.
2. What is the use of conjugate beam method over other methods ?
3. How will you use conjugate beam method for finding slope and deflection at any section of a given beam ?
4. Find the slope and deflection of a simply supported beam carrying a point load at the centre, using conjugate beam method.
5. A cantilever carries a point load at the free end. Determine the deflection at the free end, using conjugate beam method.
6. What is the relation between an actual beam and the corresponding conjugate beam for different end conditions ?
7. What do you mean by propped cantilevers and beams ? What is the use of propping the beam ?
8. How will you find the reaction at the prop ?
9. A cantilever of length  $L$ , carries a uniformly distributed load of  $w/m$  run over the entire length. It is rigidly propped at the free end. Prove that :

$$(i) \text{ Prop reaction} = \frac{3}{8} w.L \text{ and}$$

$$(ii) \text{ Deflection at the centre} = \frac{WL^4}{192EI}$$

10. A simply supported beam of length  $L$ , carries a uniformly distributed load of  $w/m$  run over the entire span. The beam is rigidly propped at the centre. Determine :
- Prop reactions,
  - Support reactions,
  - B.M. at the centre, and
  - Point of contraflexure, if any.

### (B) Numerical Problems

- A beam 6 m long, simply supported at its ends, is carrying a point load at 50 kN at its centre. The moment of inertia of the beam is  $76 \times 10^6 \text{ mm}^4$ . If  $E = 2.1 \times 10^5 \text{ N/mm}^2$ , determine the slope at the supports and deflection at the centre of the beam using conjugate beam method.  
[Ans. (i) 3.935 and 13.736 mm]
- A simply supported beam of length 10 m, carries a point load of 10 kN at a distance 6 m from the left support. If  $E = 2 \times 10^5 \text{ N/mm}^2$  and  $I = 1 \times 10^8 \text{ mm}^4$ , determine the slope at the left support and deflection under the point load using conjugate beam method.  
[Ans. 6.00028 rad. and 0.96 mm]
- A beam of length 6 m is simply supported at its ends and carries two point loads of 48 kN and 40 kN at a distance of 1 m and 3 m respectively from the left support. Find the deflection under each load. Take  $E = 2 \times 10^5 \text{ N/mm}^2$  and  $I = 85 \times 10^6 \text{ mm}^4$ . Use conjugate beam method.  
[Ans. 9.019 mm and 16.7 mm]
- A beam  $AB$  of span  $L$  is simply supported at  $A$  and  $B$  and carries a point load  $W$  at the centre  $C$  of the span. The moment of inertia of the beam section is  $I$  for the left half and  $2I$  for the right half. Calculate the slope at each end and deflection at the centre.  
[Ans.  $\theta_A = \frac{5WL^2}{96EI}$ ,  $\theta_B = \frac{WL^2}{24EI}$  and  $y_C = \frac{WL^3}{68EI}$ ]
- A cantilever of length 3 m is carrying a point load of 25 kN at the free end. If  $I = 10^8 \text{ mm}^4$  and  $E = 2.1 \times 10^5 \text{ N/mm}^2$ , then determine : (i) slope of the cantilever at the free end and (ii) deflection at the free end using conjugate beam method.  
[Ans. 0.005357 rad. and 10.71 mm]
- A cantilever of length 3 m is carrying a point load of 50 kN at a distance of 2 m from the fixed end. If  $I = 10^8 \text{ mm}^4$  and  $E = 2 \times 10^5 \text{ N/mm}^2$ , find (i) slope at the free end, and (ii) deflection at the free end using conjugate beam method.  
[Ans. 0.005 rad. and 11.67 mm]
- A cantilever of length 5 m carries a point load of 24 kN at its centre. The cantilever is propped rigidly at the free end. Determine the reaction at the rigid prop.  
[Ans. 7.5 kN]
- A cantilever of length 4 m carries a uniformly distributed load of 2 kN/m run over the whole length. The cantilever is propped rigidly at the free end. If  $E = 1 \times 10^5 \text{ N/mm}^2$  and  $I = 10^8 \text{ mm}^4$ , then determine :  
  - reaction at the rigid prop
  - the deflection at the centre of the cantilever, and
  - magnitude and position of maximum deflection.  
[Ans. (i) 3 kN (ii) 0.0667 mm (iii)  $x = 1.688 \text{ m}$ ,  $y_{\max} = 0.0693 \text{ mm}$ ]
- A simply supported beam of length 8 m carries a uniformly distributed load of 1 kN/m run over the entire length. The beam is rigidly propped at the centre. Determine : (i) reaction at the prop (ii) reactions at the supports (iii) net B.M. at the centre and (iv) positions of points of contraflexures.  
[Ans. (i) 5 kN (ii) 1.5 kN (iii) -2.0 kNm (iv) 3 m from each support]
- A cantilever of length 10 m carries a uniformly distributed load of 800 N/m length over the whole length. The free end of the cantilever is supported on a prop. The prop sinks by 5 mm. If  $E = 3 \times 10^5 \text{ N/mm}^2$  and  $I = 10^8 \text{ mm}^4$ , then find the prop reaction.  
[Ans. 2750 N]

# 15

## Fixed and Continuous Beams

### 15.1. INTRODUCTION

A beam whose both ends are fixed is known as a fixed beam. Fixed beam is also called a *built-in* or *encaster beam*. In case of a fixed beam both its ends are rigidly fixed and the slope and deflection at the fixed ends are zero. But the fixed ends are subjected to end moments. Hence end moments are not zero in case of a fixed beam.

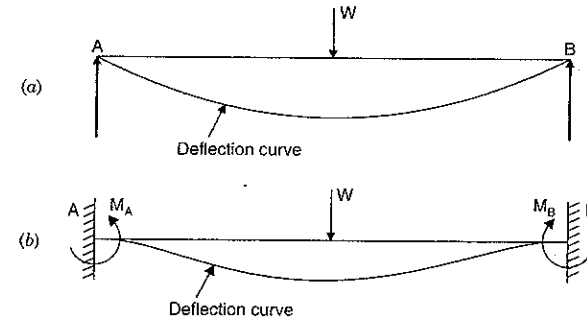

Fig. 15.1

In case of simply supported beam, the deflection is zero at the ends. But the slope is not zero at the ends as shown in Fig. 15.1 (a).

In case of fixed beam, the deflection and slope are zero at the fixed ends as shown in Fig. 15.1 (b). The slope will be zero at the ends if the deflection curve is horizontal at the ends. To bring the slope back to zero (*i.e.*, to make the deflection curve horizontal at the fixed ends), the end moments  $M_A$  and  $M_B$  will be acting in which  $M_A$  will be acting anti-clockwise and  $M_B$  will be acting clockwise as shown in Fig. 15.1 (b).

A beam which is supported on more than two supports is known as continuous beam. This chapter deals with the fixed beams and continuous beam. In case of fixed beams the B.M. diagram, slope and deflection for various types of loading such as point loads, uniformly distributed load and combination of point load and u.d.l., are discussed. In case of continuous beam, Clapeyron's equation of three moments and application of this equation to the continuous beam of simply supported ends and fixed ends are explained.

15.2. BENDING MOMENT DIAGRAM FOR FIXED BEAMS

Fig. 15.1 (c) shows a fixed beam AB of length L subjected to two loads W and 2W at a distance of  $\frac{L}{4}$  from each ends.

Let  $R_A$  = Reaction at A

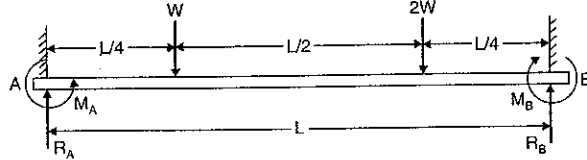

Fig. 15.1 (c)

- $R_B$  = Reaction at B
- $M_A$  = Fixed end moment at A
- $M_B$  = Fixed end moment at B

The above four quantities i.e.,  $R_A, R_B, M_A$  and  $M_B$  are unknown.

The values of  $R_A, R_B, M_A$  and  $M_B$  are calculated by analysing the given beam in the following two stages :

(i) A simply supported beam subjected to given vertical loads as shown in Fig. 15.2.

Consider the beam AB as simply supported.

- Let  $R_A^*$  = Reaction at A due to vertical loads
- $R_B^*$  = Reaction at B due to vertical loads.

Taking moments about A, we get

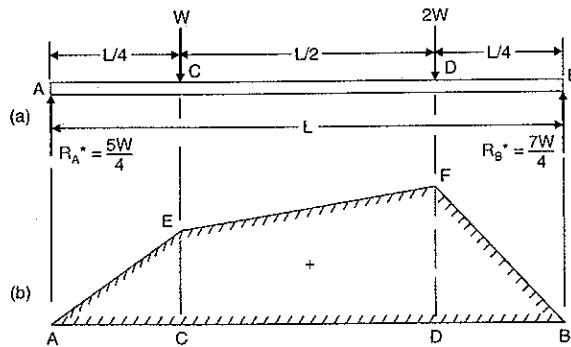

B.M. diagram considering beam as simply supported

Fig. 15.2

$$R_B^* \times L = W \times \frac{L}{4} + 2W \times \frac{3L}{4}$$

$$R_B^* = \frac{W}{4} + \frac{6W}{4} = \frac{7W}{4}$$

$$R_A^* = \text{Total load} - R_B^*$$

and

$$= 3W - \frac{7W}{4} = \frac{5W}{4}$$

B.M. at A = 0, B.M. at B = 0.

$$\text{B.M. at C} = \frac{5W}{4} \times \frac{L}{4} = \frac{5WL}{16}$$

$$\text{B.M. at D} = \frac{7W}{4} \times \frac{L}{4} = \frac{7WL}{16}$$

Now B.M. diagram can be drawn as shown in Fig. 15.2 (b). In this case, B.M. at any point is a sagging (+ve) moment.

(ii) A simply supported beam subjected to end moments only (without given loading) as shown in Fig. 15.3.

- Let  $M_A$  = Fixed end moment at A
- $M_B$  = Fixed end moment at B
- R = Reaction\* at each end due to these moments.

As the vertical loads acting on the beam are not symmetrical (they are W at distance L/4 from A and 2W at a distance L/4 from B), the fixed end moments will be different.

Suppose  $M_B$  is more than  $M_A$  and reaction R at B is acting upwards. Then reaction R at A will be acting downwards as there is no other load on the beam. ( $\Sigma Fy = 0$ ). Taking moments about A, we get clockwise moment at A = Anti-clockwise moment at A.

$$M_B = M_A + R.L$$

$$R = \frac{M_B - M_A}{L} \quad \dots(A)$$

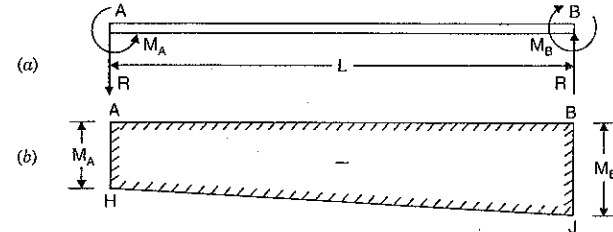

B.M. diagram due to end moments

Fig. 15.3

As  $M_B$  has been assumed more than  $M_A$ , the R.H.S. of equation (A) will be positive. This means the magnitude of reaction R at B is positive. This also means that the direction of reaction R at B is according to our assumption. Hence the reaction R will be upwards at B and downwards at A as shown in Fig. 15.3 (a). The B.M. diagram for this condition is shown in Fig. 15.3 (b). In this case, B.M. at any point is a hogging (-ve) moment.

Since the directions of the two bending moments given by Fig. 15.2 (b) and Fig. 15.3 (b) are opposite to each other, therefore their resultant effect may be obtained by drawing the two moments on the same side of the base AB, as shown in Fig. 15.4.

\*The reaction at each end will be equal. There is no vertical load on the beam hence reaction at A + reaction at B = 0. Or reaction at A = - reaction at B.

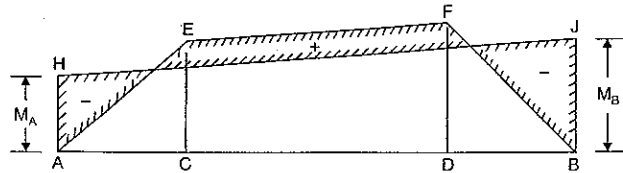

Resultant B.M. diagram

Fig. 15.4

Now the final reactions  $R_A$  and  $R_B$  are given by

$$R_A = R_A^* - R$$

and

$$R_B = R_B^* + R$$

In the above two equations,  $R_A^*$  and  $R_B^*$  are already calculated. They are :  $R_A^* = 5W/4$  and  $R_B^* = 7W/4$ . But the value of  $R$  is in terms of  $M_B$  and  $M_A$ . It is given by  $R = (M_B - M_A)/L$ . Hence to find the value of  $R$ , we must calculate the value of  $M_B$  and  $M_A$  first.

**To find the values of  $M_A$  and  $M_B$**

Let  $M_x$  = B.M. at any section at a distance  $x$  from A due to vertical loads

$M_x'$  = B.M. at any section at a distance  $x$  from A due to end moments.

The resultant B.M. at any section at a distance  $x$  from A

$$= M_x - M_x' \quad (M_x \text{ is +ve but } M_x' \text{ is -ve)}$$

But B.M. at any section is also equal to  $EI \frac{d^2y}{dx^2}$

$$\therefore EI \frac{d^2y}{dx^2} = M_x - M_x' \quad \dots(i)$$

Integrating the above equation for the entire length, we get

$$EI \left[ \frac{dy}{dx} \right]_0^L = \int_0^L M_x dx - \int_0^L M_x' dx$$

But  $\frac{dy}{dx}$  represents the slope. And slope at the fixed ends i.e., at A and B are zero. The above equation can be written as

$$EI \left[ \left( \frac{dy}{dx} \text{ at } x=L \right) - \left( \frac{dy}{dx} \text{ at } x=0 \right) \right]$$

$$= \int_0^L M_x dx - \int_0^L M_x' dx$$

$$EI [0 - 0] = \int_0^L M_x dx - \int_0^L M_x' dx$$

$$\text{or} \quad 0 = \int_0^L M_x dx - \int_0^L M_x' dx \quad \dots(ii)$$

Now  $\int_0^L M_x dx$  represents the area of B.M. diagram due to vertical loads and  $\int_0^L M_x' dx$  represents the area of B.M. diagram due to end moments.

Let  $a$  = Area of B.M. diagram due to vertical loads  
 $a'$  = Area of B.M. diagram due to end moments.

$$\text{Then} \quad \int_0^L M_x dx = a$$

$$\text{and} \quad \int_0^L M_x' dx = a'$$

Substituting these values in equation (ii), we get

$$0 = a - a'$$

or

$$a = a'$$

...(15.1)

The above equation shows that area of B.M. diagram due to vertical loads is equal to the area of B.M. diagram due to end moments.

Again consider the equation (i)

$$EI \frac{d^2y}{dx^2} = M_x - M_x'$$

Multiplying the above equation by  $x$ , we get

$$EI x \frac{d^2y}{dx^2} = x M_x - x M_x'$$

Integrating for the whole length of the beam i.e., from 0 to  $L$ , we get

$$\int_0^L EI x \frac{d^2y}{dx^2} dx = \int_0^L x M_x dx - \int_0^L x M_x' dx$$

$$EI \int_0^L x \frac{d^2y}{dx^2} dx = \int_0^L x M_x dx - \int_0^L x M_x' dx \quad \dots(iii)$$

In the above equation,  $M_x dx$  represents the area of B.M. diagram due to vertical loads at a distance  $x$  from the end A. And the term  $(x M_x dx)$  represents the moment of area of B.M. diagram about the end A. Hence  $\int_0^L x M_x dx$  represents the moment of the total area of B.M. diagram due to vertical loads about A, and it is equal to total area of B.M. diagram due to vertical loads multiplied by the distance of C.G. of area from A,

$$\therefore \int_0^L x M_x dx = a \bar{x}$$

where  $\bar{x}$  = Distance of the C.G. of B.M. diagram due to vertical loads.

$$\text{Similarly} \quad \int_0^L x M_x' dx = a' \bar{x}'$$

where  $\bar{x}'$  = Distance of the C.G. of B.M. diagram due to end moments.

Substituting the above values in equation (iii), we get

$$EI \int_0^L x \frac{d^2y}{dx^2} dx = a \bar{x} - a' \bar{x}'$$

$$\text{or} \quad EI \left[ x \frac{dy}{dx} - y \right]_0^L = a \bar{x} - a' \bar{x}' \quad \left[ \because \frac{d}{dx} \left( x \frac{dy}{dx} - y \right) = \left( x \frac{d^2y}{dx^2} + \frac{dy}{dx} \right) - \frac{dy}{dx} = x \frac{d^2y}{dx^2} \right]$$

or 
$$EI \left[ \left( x \frac{dy}{dx} - y \right)_{\text{at } x=L} - \left( x \frac{dy}{dx} - y \right)_{\text{at } x=0} \right] = a\bar{x} - a'\bar{x}'$$

or 
$$EI [(L\theta_B - y_B) - (0 \times \theta_A - y_A)] = a\bar{x} - a'\bar{x}'$$

Since slope and deflection at A and B are zero, hence  $\theta_A, \theta_B, y_A$  and  $y_B$  are zero.

$$0 = a\bar{x} - a'\bar{x}'$$

or 
$$a\bar{x} = a'\bar{x}' \quad \dots(15.2)$$

But from equation (15.1), we have

$$a = a' \quad \dots(15.3)$$

$$\bar{x} = \bar{x}'$$

Hence the distance of C.G. of B.M. diagram due to vertical loads from A is equal to the distance of C.G. of B.M. diagram due to end moments from A.

Now by using equations (15.1) and (15.3) the unknowns  $M_A$  and  $M_B$  can be calculated.

This also means that  $M_A$  and  $M_B$  can be calculated by

(i) equating the area of B.M. diagram due to vertical loads to the area of B.M. diagram due to end moments.

(ii) equating the distance of C.G. of B.M. diagram due to vertical loads to the distance of C.G. of B.M. diagram due to end moments. The distance of C.G. must be taken from the same end in both cases.

### 15.3. SLOPE AND DEFLECTION FOR A FIXED BEAM CARRYING A POINT LOAD AT THE CENTRE

Fig. 15.5 (a) shows a fixed beam AB of length L, carrying a point load W at the centre C of the beam.

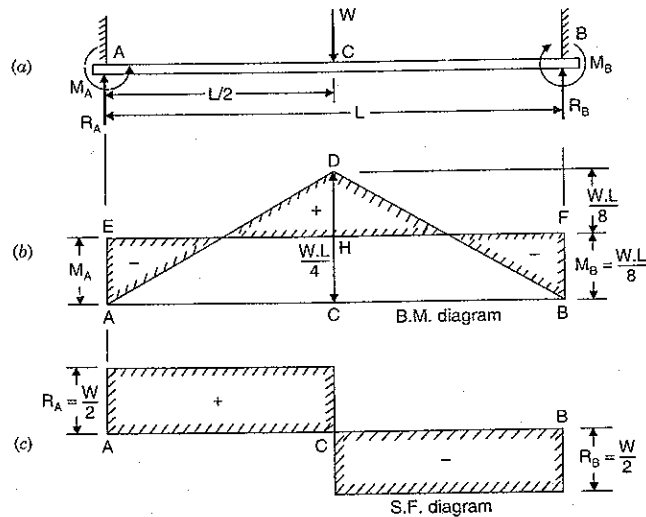

Fig. 15.5

Let  $M_A$  = Fixed end moment at A

$M_B$  = Fixed end moment at B

$R_A$  = Reaction at A

$R_B$  = Reaction at B.

The above four are unknown i.e.,  $R_A, R_B, M_A$  and  $M_B$  are unknown.

(i) *B.M. Diagram*

Due to symmetry, the end moments  $M_A$  and  $M_B$  will be equal. Hence the B.M. diagram due to end moments will be a rectangle as shown in Fig. 15.5 (b) by AEFB. Here the magnitude of  $M_A$  and  $M_B$  are unknown. The bending moment diagram for a simply supported beam carrying a point load at the centre will be a triangle with the maximum B.M. at the centre equal to  $\frac{W.L}{4}$ . The B.M. diagram for this case is shown in Fig. 15.5 (b) by a triangle ADC in which

$$CD = \frac{W.L}{4}$$

Now according to equation (15.1), area of B.M. diagram due to vertical loads should be equal to the area of B.M. diagram due to end moments.

$\therefore$  Equating the areas of the two bending moment diagrams, we get

$$\text{Area of triangle ADC} = \text{Area of rectangle AEFB}$$

or 
$$\frac{1}{2} \times AB \times CD = AB \times AE$$

or 
$$\frac{1}{2} \times L \times \frac{W.L}{4} = L \times M_A$$

$$M_A = \frac{W.L}{8}$$

Also 
$$M_B = M_A = \frac{W.L}{8} \quad \dots(15.4)$$

Now the B.M. diagram can be drawn as shown in Fig. 15.5 (b).

(ii) *S.F. Diagram*

Equating the clockwise moments and anti-clockwise moments about A, we get

$$R_B \times L + M_A = M_B + W \cdot \frac{L}{2}$$

But 
$$M_A = M_B$$

$$\therefore R_B \times L = W \cdot \frac{L}{2}$$

or 
$$R_B = \frac{W}{2}$$

Due to symmetry, 
$$R_A = \frac{W}{2}$$

Now the S.F. diagram can be drawn as shown in Fig. 15.5 (c).

There will be two points of contraflexure at a distance of  $\frac{L}{4}$  from the ends.

## (iii) Slope and Deflection

The B.M. at any section between AC at a distance  $x$  from A is given by,

$$EI \frac{d^2y}{dx^2} = R_A \times x - M_A$$

$$= \frac{W \cdot x}{2} - \frac{W \cdot L}{8} \quad \left( \because M_A = \frac{W \cdot L}{8}, R_A = \frac{W}{2} \right)$$

Integrating the above equation, we get

$$EI \frac{dy}{dx} = \frac{W}{2} \cdot \frac{x^2}{2} - \frac{W \cdot L}{8} \cdot x + C_1$$

where  $C_1$  is a constant of integration.

At  $x = 0$ ,  $\frac{dy}{dx} = 0$ . Hence  $C_1 = 0$

Therefore the above equation becomes as

$$EI \frac{dy}{dx} = \frac{Wx^2}{4} - \frac{W \cdot L}{8} x \quad \dots(i)$$

The above equation (i) gives the slope of the beam at any point :

Integrating equation (i) again, we get

$$EIy = \frac{W}{4} \cdot \frac{x^3}{3} - \frac{WL}{8} \cdot \frac{x^2}{2} + C_2$$

where  $C_2$  is another constant of integration. At  $x = 0$ ,  $y = 0$ . Hence  $C_2 = 0$ .

Therefore the above equation becomes as

$$EIy = \frac{W \cdot x^3}{12} - \frac{W \cdot Lx^2}{16} \quad \dots(ii)$$

The above equation (ii) gives the deflection of the beam at any point. The deflection is

maximum at the centre of the beam, where  $x = \frac{L}{2}$ . Hence substituting  $x = \frac{L}{2}$  in equation (ii),

we get

$$EIy_{max} = \frac{W}{12} \left( \frac{L}{2} \right)^3 - \frac{W \cdot L}{16} \cdot \left( \frac{L}{2} \right)^2$$

$$= \frac{WL^3}{96} - \frac{WL^3}{64} = \frac{2WL^3 - 3WL^3}{192} = - \frac{WL^3}{192}$$

or

$$y_{max} = \frac{-WL^3}{192EI}$$

Minus sign means that the deflection is downwards.

$$\therefore \text{Downward deflection, } y_{max} = \frac{WL^3}{192EI} \quad \dots(15.5)$$

**Note.** The deflection at the centre of a simply supported beam carrying a point load  $W$  at the centre is  $\frac{WL^3}{48EI}$ . Hence the deflection of the simply supported beam is four times the deflection of the fixed beam.

Or in other words, the deflection of a fixed beam is one fourth times the deflection of the simply supported beam. Hence when fixed beams are used, the deflection will be less.

**Problem 15.1.** A fixed beam AB, 6 m long, is carrying a point load of 50 kN at its centre. The moment of inertia of the beam is  $78 \times 10^6 \text{ mm}^4$  and value of  $E$  for beam material is  $2.1 \times 10^5 \text{ N/mm}^2$ . Determine :

(i) Fixed end moments at A and B, and

(ii) Deflection under the load.

**Sol.** Given :

Length,  $L = 6 \text{ m} = 6000 \text{ mm}$

Point load,  $W = 50 \text{ kN} = 50000 \text{ N}$

M.O.I.,  $I = 78 \times 10^6 \text{ mm}^4$

Value of  $E = 2.1 \times 10^5 \text{ N/mm}^2$

Let  $M_A =$  Fixed end moment at A,

$M_B =$  Fixed end moment at B,

$y_{max} =$  Deflection under the central point load.

Using equation (15.4), we get

$$M_A = M_B = \frac{W \cdot L}{8}$$

$$= \frac{50 \times 6}{8} = 37.5 \text{ kNm. Ans.}$$

Using equation (15.5), we get

$$y_{max} = \frac{WL^3}{192EI}$$

$$= \frac{50000 \times 6000^3}{192 \times 2.1 \times 10^5 \times 78 \times 10^6} = 3.434 \text{ mm. Ans.}$$

**Alternate Method**

Fig. 15.5A(b) shows the simply supported beam, which is having Max. B.M. at the centre equal to  $R_A \times 3 = 25 \times 3 = 75 \text{ kNm}$ . Fig. 15.5A (c) shows the B.M. diagram for simply supported beam.

Fig. 15.5A(d) shows the fixed beam with end moments only. Due to symmetry end moments are equal. Hence  $M_A = M_B$ . Fig. 15.5A (e) shows the B.M. diagram due to end moments only. This diagram is a rectangle.

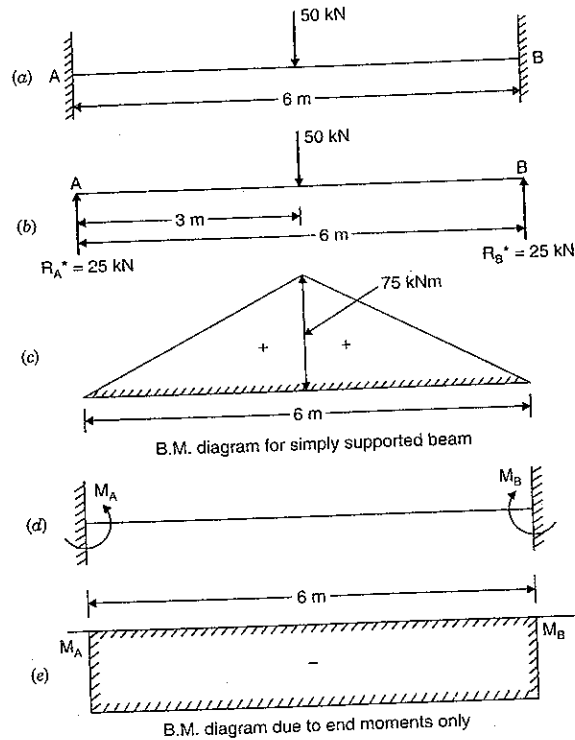

Fig. 15.5A

Equating the areas of two B.M. diagrams, we get  
 Area of B.M. diagram for simply supported beam  
 = Area of B.M. diagram due to end moments.

i.e., 
$$\frac{75 \times 6}{2} = M_A \times 6$$

or 
$$M_A = \frac{75}{2} = 37.5 \text{ kNm}$$

But 
$$M_A = M_B$$

$$M_A = M_B = 37.5 \text{ kNm. Ans.}$$

**15.4. SLOPE AND DEFLECTION FOR A FIXED BEAM CARRYING AN ECCENTRIC POINT LOAD**

Fig. 15.6 (a) shows a fixed beam AB of length L, carrying a point load W at C at a distance of 'a' from A and at a distance of 'b' from B. The fixed end moments  $M_A$  and  $M_B$  and also reactions at A and B i.e.,  $R_A$  and  $R_B$  are shown in the same figure.

(i) B.M. Diagram

As the load is not acting symmetrically, therefore  $M_A$  and  $M_B$  will be different. In this case  $M_B$  will be more than  $M_A$  as the load is nearer to point B. The B.M. diagram due to end moments will be trapezium as shown in Fig. 15.6 (b) by AEFB. Here the length AE (i.e.,  $M_A$ ) and BF (i.e.,  $M_B$ ) are unknown.

The B.M. diagram for a simply supported beam carrying an eccentric point load will be triangle with maximum B.M. under the point load equal to  $\frac{W \cdot a \cdot b}{L}$ . The B.M. diagram for this case is shown in Fig. 15.6 (b) by a triangle ADB in which  $CD = \frac{W \cdot a \cdot b}{L}$ .

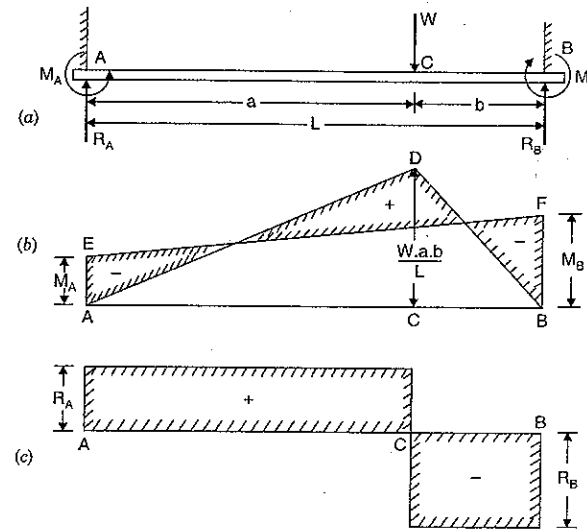

Fig. 15.6

Equating the areas of the two bending moment diagrams, we get  
 Area of trapezium AEFB = Area of triangle ADB

$$\frac{1}{2} (AE + BF) \cdot AB = \frac{1}{2} \times AB \times CD$$

$$\frac{1}{2} (M_A + M_B) \cdot L = \frac{1}{2} \times L \frac{W \cdot a \cdot b}{L}$$

or 
$$M_A + M_B = \frac{W \cdot a \cdot b}{L} \quad \dots(i)$$

Now using equation (15.3),

$$\bar{x} = \bar{x}'$$

or Distance of C.G. of B.M. diagram due to vertical loads from A = Distance of C.G. of B.M. diagram due to end moments from A.

Now

$$\bar{x}' = \frac{A_1 x_1 + A_2 x_2}{(A_1 + A_2)} \quad [\text{See Fig. 15.7 (a)}]$$

$$\begin{aligned} &= \frac{(M_A \cdot L) \cdot \frac{L}{2} + \frac{1}{2} \cdot L(M_B - M_A) \times \frac{2L}{3}}{M_A \cdot L + \frac{1}{2} \cdot L(M_B - M_A)} \\ &= \frac{M_A \cdot \frac{L}{2} + (M_B - M_A) \cdot \frac{L}{3}}{M_A + \frac{1}{2}(M_B - M_A)} = \frac{3M_A \cdot L + 2M_B \cdot L - 2M_A \cdot L}{3(2M_A + M_B - M_A)} \\ &= \frac{M_A \cdot L + 2M_B \cdot L}{3(M_A + M_B)} = \frac{(M_A + 2M_B) \cdot L}{3(M_A + M_B)} \end{aligned}$$

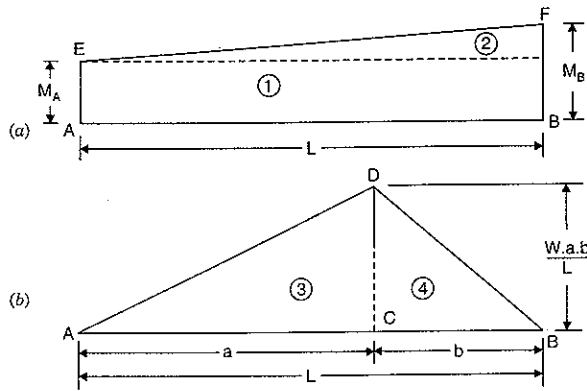

Fig. 15.7

and

$$\bar{x} = \frac{A_3 x_3 + A_4 x_4}{(A_3 + A_4)} \quad [\text{See Fig. 15.7 (b)}]$$

$$= \frac{\left(\frac{1}{2} \times a \times CD\right) \times \frac{2a}{3} + \frac{1}{2} \cdot b \cdot CD \times \left(a + \frac{b}{3}\right)}{\frac{1}{2} \cdot a \cdot CD + \frac{1}{2} \cdot b \cdot CD}$$

$$= \frac{\frac{2a^2}{3} + b\left(a + \frac{b}{3}\right)}{a + b} \quad \left(\text{Cancelling } \frac{CD}{2}\right)$$

$$= \frac{2a^2 + 3ab + b^2}{3(a + b)} = \frac{2a^2 + 2ab + ab + b^2}{3(a + b)}$$

$$= \frac{2a(a + b) + b(a + b)}{3(a + b)} = \frac{(2a + b)(a + b)}{3(a + b)}$$

$$= \frac{2a + b}{3} = \frac{a + (a + b)}{3} = \frac{a + L}{3} \quad (\because a + b = L)$$

But

$$\bar{x}' = \bar{x}$$

$$\therefore \frac{(M_A + 2M_B) \cdot L}{3(M_A + M_B)} = \frac{a + L}{3}$$

or

$$M_A + 2M_B = \frac{(a + L)(M_A + M_B)}{L}$$

$$\begin{aligned} &= \frac{(a + L)}{L} \cdot \frac{W \cdot a \cdot b}{L} \quad \left[\because M_A + M_B = \frac{W \cdot a \cdot b}{L} \text{ from equation (i)}\right] \\ &= (a + L) \cdot \frac{W \cdot a \cdot b}{L^2} \quad \dots(ii) \end{aligned}$$

Subtracting equation (i) from equation (ii), we get

$$M_B = (a + L) \cdot \frac{W \cdot a \cdot b}{L^2} - \frac{W \cdot a \cdot b}{L}$$

$$= \frac{W \cdot a \cdot b}{L} \left(\frac{a + L}{L} - 1\right)$$

$$= \frac{W \cdot a \cdot b}{L} \left(\frac{a + L - L}{L}\right) = \frac{W \cdot a^2 \cdot b}{L^2} \quad \dots(iii)$$

Substituting the value of  $M_B$  in equation (i), we get

$$M_A + \frac{W \cdot a^2 \cdot b}{L^2} = \frac{W \cdot a \cdot b}{L}$$

 $\therefore$ 

$$M_A = \frac{W \cdot a \cdot b}{L} - \frac{W a^2 b}{L^2}$$

$$= \frac{W \cdot a \cdot b}{L^2} (L - a) = \frac{W \cdot a \cdot b \cdot b}{L^2} \quad (\because L - a = b)$$

$$= \frac{W \cdot a \cdot b^2}{L^2} \quad \dots(iv)$$

Now  $M_A$  and  $M_B$  are known and hence bending moment diagram can be drawn. From equations (iii) and (iv), it is clear that if  $a > b$  then  $M_B > M_A$ .

(ii) S. F. Diagram

Equating the clockwise moments and anticlockwise about A,

$$R_B \times L + M_A = M_B + W \cdot a$$

$$\therefore R_B = \frac{(M_B - M_A) + W \cdot a}{L}$$

Similarly

$$R_A = \frac{(M_A - M_B) + W \cdot b}{L}$$

By substituting the values of  $M_A$  and  $M_B$  from equations (iii) and (iv), in the above equations, we shall get  $R_A$  and  $R_B$ . Now S.F. can be drawn as shown in Fig. 15.6 (c).

(iii) Slope and Deflection

The B.M. at any section between AC at a distance  $x$  is given by

$$EI \frac{d^2 y}{dx^2} = R_A \times x - M_A$$



Substituting the value of  $R_A$  in the above equation, we get

$$\begin{aligned} EI \frac{d^2 y}{dx^2} &= \left[ \frac{(M_A - M_B) + W \cdot b}{L} \right] \cdot x - M_A \\ &= \frac{(M_A - M_B)}{L} x + \frac{W \cdot b}{L} \cdot x - M_A \\ &= \frac{W \cdot b}{L} \cdot x - \left[ M_A + (M_B - M_A) \frac{x}{L} \right] \end{aligned}$$

Substituting the values of  $M_A$  and  $M_B$ , we get

$$\begin{aligned} EI \frac{d^2 y}{dx^2} &= \frac{W \cdot b}{L} \cdot x - \left[ \frac{W \cdot a \cdot b^2}{L^2} + \left( \frac{W \cdot a^2 \cdot b}{L^2} - \frac{W \cdot a \cdot b^2}{L^2} \right) \frac{x}{L} \right] \\ &= \frac{W \cdot b \cdot x}{L} - \frac{W \cdot a \cdot b^2}{L^2} - \left( \frac{W \cdot a^2 \cdot b}{L^2} - \frac{W \cdot a \cdot b^2}{L^2} \right) \frac{x}{L} \\ &= \frac{W \cdot b \cdot x}{L} - \frac{W \cdot a \cdot b^2}{L^2} - \frac{W \cdot a \cdot b}{L^2} (a - b) \cdot \frac{x}{L} \\ &= \frac{W \cdot b \cdot x}{L} - \frac{W \cdot a \cdot b}{L^2} (a - b) \cdot \frac{x}{L} - \frac{W \cdot a \cdot b^2}{L^2} \\ &= \frac{W \cdot b}{L^3} [L^2 x - a(a - b)x] - \frac{W \cdot a \cdot b^2}{L^2} \\ &= \frac{W \cdot b}{L^3} (L^2 - a^2 + ab)x - \frac{W \cdot a \cdot b^2}{L^2} \end{aligned}$$

But  $L = a + b$

$$\therefore L^2 = (a + b)^2 = a^2 + b^2 + 2ab.$$

Substituting the value of  $L^2$  in the above equation, we get

$$\begin{aligned} \therefore EI \frac{d^2 y}{dx^2} &= \frac{W \cdot b}{L^3} (a^2 + b^2 + 2ab - a^2 + ab)x - \frac{W \cdot a \cdot b^2}{L^2} \\ &= \frac{W \cdot b}{L^3} (b^2 + 3ab)x - \frac{W \cdot a \cdot b^2}{L^2} \\ &= \frac{W \cdot b^2}{L^3} (b + 3a)x - \frac{W \cdot a \cdot b^2}{L^2} \end{aligned}$$

Integrating the above equation, we get

$$EI \frac{dy}{dx} = \frac{W \cdot b^2}{L^3} (b + 3a) \cdot \frac{x^2}{2} - \frac{W \cdot a \cdot b^2}{L^2} x + C_1$$

where  $C_1$  is a constant of integration.

At  $x = 0$ ,  $\frac{dy}{dx} = 0$ . Hence  $C_1 = 0$ .

$$\therefore EI \frac{dy}{dx} = \frac{W \cdot b^2}{2L^3} (b + 3a) \cdot x^2 - \frac{W \cdot a \cdot b^2}{L^2} \cdot x \quad \dots(v)$$

Integrating again, we get

$$EIy = \frac{W \cdot b^2}{2L^3} (b + 3a) \cdot \frac{x^3}{3} - \frac{W \cdot a \cdot b^2}{L^2} \cdot \frac{x^2}{2} + C_2$$

where  $C_2$  is another constant of integration. At  $x = 0$ ,  $y = 0$ . Hence  $C_2 = 0$ .

$$\therefore EIy = \frac{W \cdot b^2}{6L^3} (b + 3a)x^3 - \frac{W \cdot a \cdot b^2}{2L^2} \cdot x^2 \quad \dots(vi)$$

The deflection under the load is obtained by substituting  $x = a$  in the above equation. Let  $y_c$  is the deflection under the load, then

$$\begin{aligned} EIy_c &= \frac{W \cdot b^2}{6L^3} (b + 3a) \cdot a^3 - \frac{W \cdot a \cdot b^2}{2L^2} \cdot a^2 \\ &= \frac{W \cdot b^2 \cdot a^3}{6L^3} \cdot (b + 3a - 3L) \\ &= -\frac{W \cdot a^3 \cdot b^2}{6L^3} (3L - 3a - b) \\ &= -\frac{W \cdot a^3 \cdot b^2}{6L^3} [3(L - a) - b] \\ &= -\frac{W \cdot a^3 \cdot b^2}{6L^3} (3b - b) \quad (\because L - a = b) \\ &= -\frac{W \cdot a^3 \cdot b^3}{3L^3} \\ \therefore y_c &= -\frac{W \cdot a^3 \cdot b^3}{3EIL^3} \quad \dots(15.6) \end{aligned}$$

*Maximum deflection*

Since  $a > b$ , hence maximum deflection will take place between A and C. For maximum deflection,  $\frac{dy}{dx}$  should be zero. Hence substituting  $\frac{dy}{dx} = 0$  in equation (v), we get

$$\begin{aligned} 0 &= \frac{W \cdot b^2}{2L^3} (b + 3a) \cdot x^2 - \frac{W \cdot a \cdot b^2}{L^2} \cdot x \\ \frac{W \cdot a \cdot b^2}{L^2} x &= \frac{W \cdot b^2}{2L^3} (b + 3a)x^2 \\ \therefore x &= \frac{W \cdot a \cdot b^2}{L^2} \times \frac{2L^3}{W \cdot b^2 (b + 3a)} = \frac{2aL}{(b + 3a)} \quad \dots(15.7) \end{aligned}$$

Substituting this value of  $x$  in equation (vi), we get maximum deflection. If  $y_{max}$  represents the maximum deflection, then

$$EIy_{max} = \frac{W \cdot b^2}{6L^3} (b + 3a) \left( \frac{2aL}{b + 3a} \right)^3 - \frac{W \cdot a \cdot b^2}{2L^2} \times \left( \frac{2aL}{b + 3a} \right)^2$$

$$\begin{aligned}
 &= \frac{W \cdot b^2}{6L^3} \cdot \left( \frac{2aL}{b+3a} \right)^2 \left[ (b+3a) \cdot \frac{2aL}{(b+3a)} - 3aL \right] \\
 &= -\frac{Wb^2}{6L^3} \cdot \left( \frac{2aL}{b+3a} \right)^2 \cdot aL \\
 &= -\frac{Wb^2}{6L^3} \cdot \frac{4a^2L^2}{(b+3a)^2} \cdot aL = -\frac{2}{3} \cdot \frac{Wa^3b^2}{(b+3a)^2} \\
 \therefore y_{max} &= -\frac{2}{3EI} \cdot \frac{Wa^3b^2}{(b+3a)^2} \quad \dots(15.8)
 \end{aligned}$$

**Problem 15.2.** A fixed beam AB of length 3 m carries a point load of 45 kN at a distance of 2 m from A. If the flexural rigidity (i.e., EI) of the beam is  $1 \times 10^4$  kNm<sup>2</sup>, determine :

- Fixed end moments at A and B,
- Deflection under the load,
- Maximum deflection, and
- Position of maximum deflection.

**Sol.** Given :

Length,  $L = 3$  m  
 Point load,  $W = 45$  kN  
 Flexural rigidity,  $EI = 1 \times 10^4$  kNm<sup>2</sup>  
 Distance of load from A,

$$a = 2 \text{ m}$$

$\therefore$  Distance of load from B,

$$b = 1 \text{ m}$$

Let  $M_A$  and  $M_B$  = Fixed end moments,

$y_c$  = Deflection under the load

$y_{max}$  = Maximum deflection and

$x$  = Distance of maximum deflection from A.

(i) The fixed end moments at A and B are given by

$$M_A = \frac{W \cdot a \cdot b^2}{L^2} = \frac{45 \times 2 \times 1^2}{3^2} = 10 \text{ kNm. Ans.}$$

and

$$M_B = \frac{W \cdot a^2 \cdot b}{L^2} = \frac{45 \times 2^2 \times 1}{3^2} = 20 \text{ kNm. Ans.}$$

(ii) Deflection under load is given by equation (15.6) as

$$\begin{aligned}
 y_c &= -\frac{W \cdot a^3 \cdot b^3}{3EIL^3} = -\frac{45 \times 2^3 \times 1^3}{3 \times 1 \times 10^4 \times 3^3} = -0.000444 \text{ m} \\
 &= -0.444 \text{ mm. Ans.}
 \end{aligned}$$

-ve sign means the deflection is downwards.

(iii) Maximum deflection is given by equation (15.8) as

$$y_{max} = -\frac{2}{3EI} \times \frac{Wa^3 \cdot b^2}{(b+3a)^2}$$

$$\begin{aligned}
 &= -\frac{2}{3 \times 1 \times 10^4} \cdot \frac{45 \times 2^3 \times 1^2}{(1+3 \times 2)^2} = -\frac{16 \times 45}{3 \times 10^4 \times 49} \\
 &= -0.00049 \text{ m} = -0.49 \text{ mm. Ans.}
 \end{aligned}$$

(iv) The distance of maximum deflection from point A is given by equation (15.7) as

$$\begin{aligned}
 x &= \frac{2a \cdot L}{(b+3a)} \\
 &= \frac{2 \times 2 \times 3}{1+3 \times 2} = \frac{12}{7} = 1.714 \text{ m. Ans.}
 \end{aligned}$$

#### Alternate Method

Fig. 15.7A (b) shows the simply supported beam with vertical load of 45 kN at a distance of 2 m from A.

The reactions  $R_A^*$  and  $R_B^*$  due to vertical load will be :

$$3R_B^* = 45 \times 2 \quad \text{or} \quad R_B^* = 90/3 = 30 \text{ kN and } R_A^* = 45 - 30 = 15 \text{ kN.}$$

Fig. 15.7A (c) shows the B.M. diagram with max. B.M. at C and equal to  $R_A^* \times 2 = 15 \times 2 = 30$  kNm.

Fig. 15.7A (d) shows the fixed beam with end moments and reactions. As the vertical load is not acting symmetrically, therefore  $M_A$  and  $M_B$  will be different. In this case  $M_B$  will be more than  $M_A$ , as load is nearer to point B. The B.M. diagram is shown in Fig. 15.7A(e)

(i) Fixed end moments at A and B. To find the value of  $M_A$  and  $M_B$ , equate the areas of two B.M. diagrams.

$\therefore$  Area of B.M. diagram due to vertical loads

= Area of B.M. diagram due to end moments

$$\therefore A_1 + A_2 = A_3 + A_4 \quad \text{where } A_1 = \frac{30 \times 2}{2} = 30, A_2 = \frac{30 \times 1}{2} = 15$$

$$\begin{aligned}
 A_3 &= 3M_A, A_4 = \frac{(M_B - M_A) \times 3}{2} \\
 &= 1.5(M_B - M_A)
 \end{aligned}$$

$$\text{or } 30 + 15 = 3M_A + 1.5M_B - 1.5M_A$$

$$\text{or } 45 = 1.5M_A + 1.5M_B$$

$$\text{or } \frac{45}{1.5} = M_A + M_B \quad \text{or} \quad M_A + M_B = 30 \quad \dots(i)$$

Now equating the distance of C.G. of B.M. diagram due to vertical load to the distance of C.G. of B.M. diagram due to end moments from the same end (i.e., from end A)

$$\text{or } \bar{x} = \bar{x}'$$

$$\text{or } \frac{A_1x_1 + A_2x_2}{A_1 + A_2} = \frac{A_3x_3 + A_4x_4}{A_3 + A_4}$$

$$\text{or } \frac{30 \times \frac{4}{3} + 15 \times \left(2 + \frac{1}{3}\right)}{30 + 15} = \frac{3M_A \times \frac{3}{2} + 1.5(M_B - M_A) \times 2}{3M_A + 1.5M_B - 1.5M_A}$$

$$\text{or } \frac{40 + 35}{45} = \frac{4.5M_A + 3M_B - 3M_A}{1.5M_A + 1.5M_B} = \frac{1.5M_A + 3M_B}{1.5M_A + 1.5M_B}$$

or 
$$\frac{75}{45} = \frac{15(M_A + 2M_B)}{15(M_A + M_B)} \quad \text{or} \quad \frac{5}{3} = \frac{M_A + 2M_B}{M_A + M_B}$$

or 
$$5M_A + 5M_B = 3M_A + 6M_B$$

or 
$$2M_A = M_B \quad \dots(ii)$$

Solving equations (i) and (ii), we get

$$M_A = 10 \text{ kNm and } M_B = 20 \text{ kNm. Ans.}$$

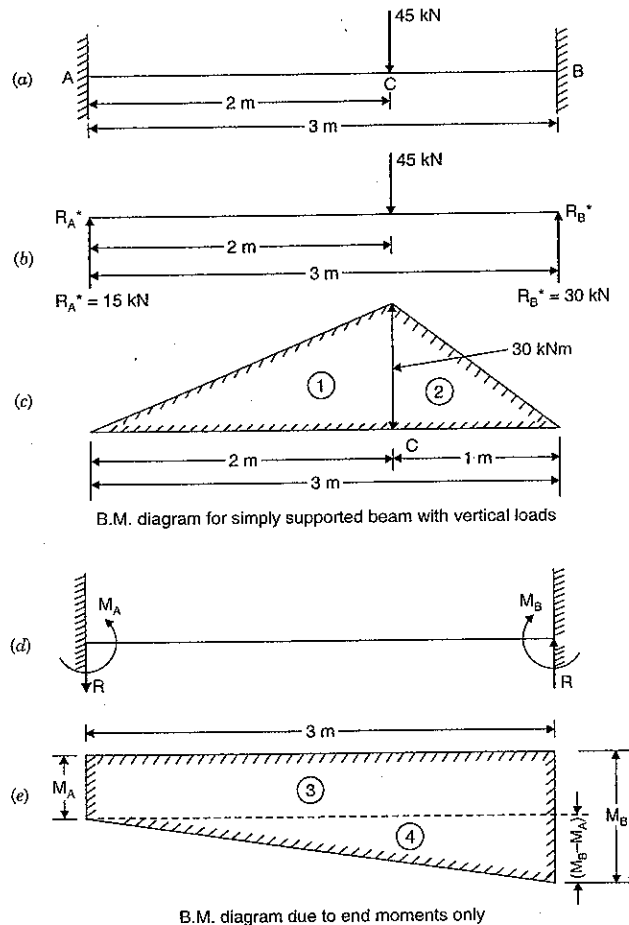

Fig. 15.7A

Let us now find the reaction  $R$  due to end moments only. As the end moments are different, hence there will be reaction at A and B. Both the reactions will be equal and opposite in direction, as there is no vertical load, when we consider end moments only. As  $M_B$  is more, the reaction  $R$  will be upwards at B and downwards at A as shown in Fig. 15.7A (d).

Taking the moments about A for Fig. 15.7A(d), we get clockwise moment at A = Anti-clockwise moments at A

$$M_B = M_A + R \times 3$$

$$\therefore R = \frac{M_B - M_A}{3} = \frac{20 - 10}{3} = \frac{10}{3} \text{ kN}$$

Now the total reaction at A and B will be,

$$R_A = R_A^* - R = 15 - \frac{10}{3} = \frac{35}{3} \text{ kN}$$

and

$$R_B = R_B^* + R = 30 + \frac{10}{3} = \frac{100}{3} \text{ kN}$$

Now, consider the fixed beam as shown in Fig. 15.7B.

The B.M. at any section between AC at a distance  $x$  from A is given by  $R_A \times x - M_A$

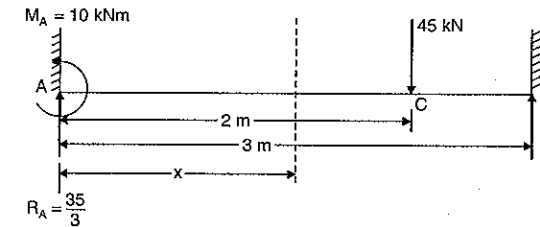

Fig. 15.7B

or

$$EI \frac{d^2 y}{dx^2} = R_A \times x - M_A$$

$$= \frac{35}{3} \times x - 10$$

Integrating, we get

$$EI \frac{dy}{dx} = \frac{35}{3} \times \frac{x^2}{2} - 10x + C_1$$

$$\text{at } x = 0, \frac{dy}{dx} = 0 \quad \therefore C_1 = 0$$

$$\therefore EI \frac{dy}{dx} = \frac{35}{6} x^2 - 10x \quad \dots(iii)$$

Integrating again, we get

$$EI \times y = \frac{35}{6} \times \frac{x^3}{3} - \frac{10x^2}{2} + C_2$$

$$\text{at } x = 0, y = 0, \quad \therefore C_2 = 0$$

$$\therefore EI \times y = \frac{35}{18} x^3 - 5x^2 \quad \dots(iv)$$

(ii) Deflection under the load

From equation (iv), we have

$$y = \frac{1}{EI} \left[ \frac{35}{18} x^3 - 5x^2 \right]$$

To find the deflection under the load, substitute  $x = 2$  m in the above equation.

$$\begin{aligned} \therefore y &= \frac{1}{EI} \left[ \frac{35}{18} \times 2^3 - 5 \times 2^2 \right] \\ &= \frac{1}{1 \times 10^4} \left[ \frac{35 \times 8}{18} - 20 \right] \quad (\because EI = 1 \times 10^4) \\ &= -0.000444 \text{ m} = -0.444 \text{ mm. Ans.} \end{aligned}$$

(-ve sign means the deflection is downwards).

(iii) Maximum deflection

Deflection ( $y$ ) will be maximum when  $\frac{dy}{dx} = 0$ .

Hence substituting the value of  $\frac{dy}{dx} = 0$  in equation (iii), we get

$$0 = \frac{35}{6}x^2 - 10x$$

$$\text{or } 0 = 35x^2 - 60x$$

$$\text{or } 0 = x(35x - 60)$$

This means that either  $x = 0$  or  $35x - 60 = 0$  for maximum deflection.

But  $x$  cannot be zero, because when  $x = 0$ ,  $y = 0$ .

$$\therefore 35x - 60 = 0$$

$$x = \frac{60}{35} = \frac{12}{7} = 1.714 \text{ m}$$

Substituting  $x = 1.714$  m in equation (iv), we get maximum deflection.

$$\therefore EIy_{\max} = \frac{35}{18}(1.714)^3 - 5(1.714)^2$$

$$\text{or } y_{\max} = \frac{1}{EI} \left[ \frac{35}{18}(1.714)^3 - 5(1.714)^2 \right]$$

$$= \frac{1}{1 \times 10^4} [9.79 - 14.69]$$

$$= 0.00049 \text{ m} = 0.49 \text{ mm. Ans.}$$

(iv) Position of maximum deflection

The maximum deflection will be at a distance of 1.714 m (i.e.,  $x = 1.714$  m) from end A.

Ans.

**Problem 15.3.** A fixed beam AB of length 6 m carries point loads of 160 kN and 120 kN at a distance of 2 m and 4 m from the left end A. Find the fixed end moments and the reactions at the supports. Draw B.M. and S.F. diagrams.

**Sol.** Given :

Length = 6 m

Load at C,  $W_C = 160$  kN

Load at D,  $W_D = 120$  kN

Distance AC = 2 m

Distance AD = 4 m

For the sake of convenience, let us first calculate the fixed end moments due to loads at C and D and then add up the moments.

(i) Fixed end moments due to load at C.

For the load at C,  $a = 2$  m and  $b = 4$  m

$$\therefore M_{A_1} = \frac{W_C \cdot a \cdot b^2}{L^2}$$

$$= \frac{160 \times 2 \times 4^2}{6^2} = 142.22 \text{ kNm}$$

$$M_{B_1} = \frac{W_C \cdot a^2 \cdot b}{L^2} = \frac{160 \times 2^2 \times 4}{6^2} = 71.11 \text{ kNm}$$

(ii) Fixed end moments due to load at D.

Similarly for the load at D,  $a = 4$  m and  $b = 2$  m

$$\therefore M_{A_2} = \frac{W_D \cdot a \cdot b^2}{L^2}$$

$$= \frac{120 \times 4 \times 2^2}{6^2} = 53.33 \text{ kNm}$$

and

$$M_{B_2} = \frac{W_D \cdot a^2 \cdot b}{L^2} = \frac{120 \times 4^2 \times 2}{6^2} = 106.66 \text{ kNm}$$

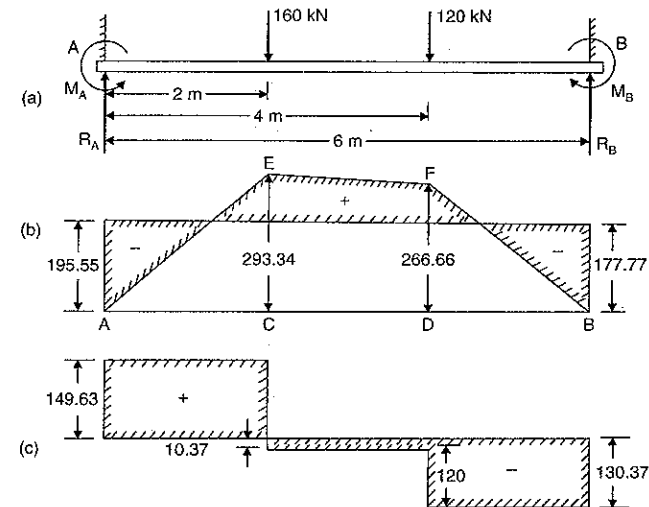

Fig. 15.8

$\therefore$  Total fixing moment at A,

$$M_A = M_{A_1} + M_{A_2} = 142.22 + 53.33$$

$$= 195.55 \text{ kNm. Ans.}$$

and total fixing moment at  $B$ ,

$$M_B = M_{B_1} + M_{B_2} = 71.11 + 106.66 \\ = 177.77 \text{ kNm. Ans.}$$

*B.M. diagram due to vertical loads*

Consider the beam  $AB$  as simply supported. Let  $R_A^*$  and  $R_B^*$  are the reactions at  $A$  and  $B$  due to simply supported beam. Taking moments about  $A$ , we get

$$R_B^* \times 6 = 160 \times 2 + 120 \times 4 \\ = 320 + 480 = 800$$

$$R_B^* = \frac{800}{6} = 133.33 \text{ kN}$$

and

$$R_A^* = \text{Total load} - R_B^* = (160 + 120) - 133.33 \\ = 146.67 \text{ kN}$$

B.M. at  $A = 0$

B.M. at  $C = R_A^* \times 2 = 146.67 \times 2 = 293.34 \text{ kNm}$

B.M. at  $D = R_B^* \times 2 = 133.33 \times 2 = 266.66 \text{ kNm}$

B.M. at  $B = 0$ .

Now the B.M. diagram due to vertical loads can be drawn as shown in Fig. 15.8 (b).

In the same figure the B.M. diagram due to fixed end moments is also shown.

*S.F. Diagram*

Let  $R_A$  = Resultant reaction at  $A$  due to fixed end moments and vertical loads

$R_B$  = Resultant reaction at  $B$ .

Equating the clockwise moments and anti-clockwise moments about  $A$ , we get

$$R_B \times 6 + M_A = 160 \times 2 + 120 \times 4 + M_B \\ R_B \times 6 + 195.55 = 320 + 480 + 177.77$$

or

$$R_B = \frac{800 + 177.77 - 195.55}{6} = 130.37 \text{ kN}$$

and

$$R_A = \text{Total load} - R_B \\ = (160 + 120) - 130.37 = 149.63 \text{ kN}$$

S.F. at  $A = R_A = 149.63 \text{ kN}$

S.F. at  $C = 149.63 - 160 = -10.37 \text{ kN}$

S.F. at  $D = -10.37 - 120 = -130.37 \text{ kN}$

S.F. at  $B = -130.37 \text{ kN}$

Now S.F. diagram can be drawn as shown in Fig. 15.8 (c).

**Alternate Method**

Fig. 15.8A (b) shows the simply supported beam with vertical loads.

Let  $R_A^*$  and  $R_B^*$  are the reactions at  $A$  and  $B$  due to vertical loads. Taking moments about  $A$ , we get

$$R_B^* \times 6 = 160 \times 2 + 120 \times 4 = 320 + 480 = 800$$

$$R_B^* = \frac{800}{6} = \frac{400}{3} = 133.33 \text{ kN}$$

and

$$R_A^* = \text{Total load} - R_B^* \\ = (160 + 120) - 133.33 = 146.67 \text{ kN}$$

B.M. at  $A = 0$

B.M. at  $C = R_A^* \times 2 = 146.67 \times 2 = 293.34 \text{ kNm}$

B.M. at  $D = R_B^* \times 2 = 133.33 \times 2 = 266.66 \text{ kNm}$

Now the B.M. diagram due to vertical loads can be drawn as shown in Fig. 15.8A(c)

Fig. 15.8A (d) shows the fixed beam with end moments only. As the load  $160 \text{ kN}$  is nearer to end  $A$ , hence  $M_A$  will be more than  $M_B$ . The B.M. diagram due to end moments is shown in Fig. 15.8A(e).

To find the values of  $M_A$  and  $M_B$ , equate the areas of two B.M. diagrams.

$\therefore$  Area of B.M. diagram due to vertical loads

= Area of B.M. diagram due to end moments

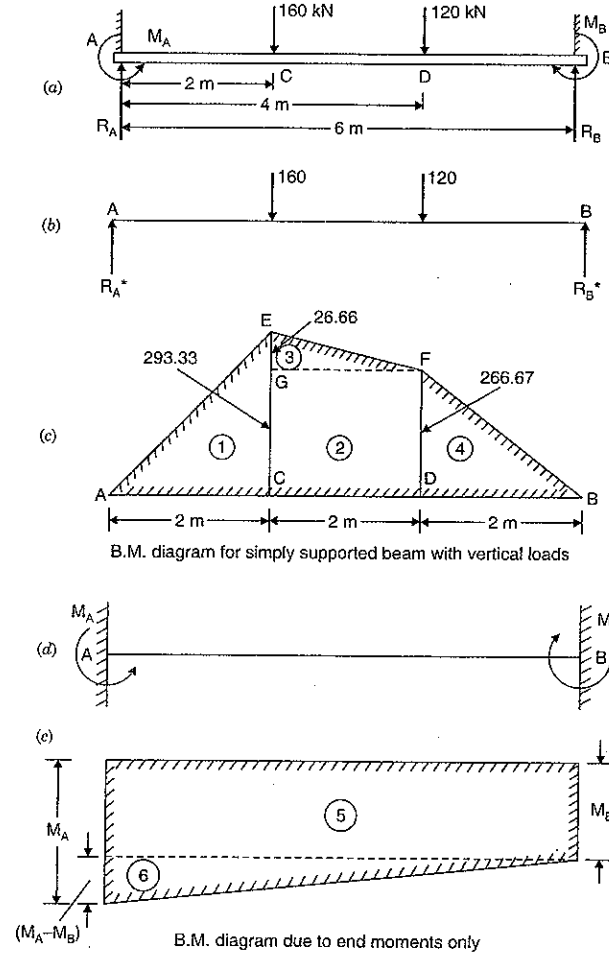

Fig. 15.8A

$$\therefore A_1 + A_2 + A_3 + A_4 = A_5 + A_6 \quad \dots(i)$$

$$\text{where } A_1 = \frac{AC \times CE}{2} = \frac{2 \times 293.33}{2} = 293.33$$

$$A_2 = CD \times DF = 2 \times 266.67 = 533.34$$

$$A_3 = \frac{GF \times GE}{2} = \frac{2 \times 26.66}{2} = 66.66$$

$$A_4 = \frac{DB \times DF}{2} = \frac{2 \times 266.67}{2} = 266.67$$

$$A_5 = M_B \times 6 = 6M_B, A_6 = \frac{6 \times (M_A - M_B)}{2} = 3(M_A - M_B) = 3M_A - 3M_B$$

Substituting these values in equation (i), we get

$$293.33 + 533.34 + 66.66 + 266.67 = 6M_B + 3M_A - 3M_B$$

$$\text{or } 1119.98 = 3M_B + 3M_A = 3(M_B + M_A)$$

$$\therefore M_B + M_A = \frac{1119.98}{3} = 373.33 \quad \dots(ii)$$

To get the other equation between  $M_A$  and  $M_B$ , equate the distance of C.G. of B.M. diagram due to vertical loads to the distance of C.G. of B.M. diagram due to end moments from end A.

$$\begin{aligned} \bar{x} &= \bar{x}' \\ \frac{A_1x_1 + A_2x_2 + A_3x_3 + A_4x_4}{A_1 + A_2 + A_3 + A_4} &= \frac{A_5x_5 + A_6x_6}{A_5 + A_6} \\ 293.33 \times \frac{4}{3} + 533.34 \times 3 + 26.66 \times \left(2 + \frac{2}{3}\right) + 266.66 \times \left(4 + \frac{2}{3}\right) & \\ &= \frac{6M_B \times 3 + 3(M_A - 3M_B) \times \frac{1}{3} \times 6}{6M_B + 3M_A - 3M_B} \end{aligned}$$

$$\begin{aligned} \frac{391.1 + 1600 + 70.91 + 1245.35}{1119.98} &= \frac{3(6M_B + 2M_A - 2M_B)}{3(M_B + M_A)} \\ 2.95 &= \frac{4M_B + 2M_A}{M_B + M_A} \end{aligned}$$

$$2.95M_B + 2.95M_A = 4M_B + 2M_A$$

$$2.95M_A - 2M_A = 4M_B - 2.95M_B$$

$$0.95M_A = 1.05M_B$$

$$M_A = \frac{1.05}{0.95} M_B = 1.1M_B \quad \dots(iii)$$

Substituting this value of  $M_A$  in equation (ii), we get

$$M_B + 1.1M_B = 373.33$$

$$\text{or } M_B = \frac{373.33}{2.1} = 177.77 \text{ kNm. Ans.}$$

From equation (iii),  $M_A = 1.1 \times 177.77 = 195.55 \text{ kNm. Ans.}$

### Combined B.M. Diagram

$M_A = 195.55 \text{ kNm}$  and  $M_B = 177.77 \text{ kNm}$ . Now the combined B.M. diagram can be drawn as shown in Fig. 15.8 (b).

To draw the S.F. diagram, let us first find the values of resultant reactions due to vertical loads and fixed end moments  $R_A$  and  $R_B$ . Refer to Fig. 15.8A(a). Taking moments about A, we get clockwise moments at A = Anti-clockwise moments at A

$$\therefore 160 \times 2 + 120 \times 4 + M_B = M_A + R_B \times 6$$

$$\text{or } 320 + 480 + M_B = M_A + 6R_B$$

$$\text{or } 800 + 177.77 = 195.55 + 6R_B$$

$$\therefore R_B = \frac{800 + 177.77 - 195.55}{6} = 130.37 \text{ kN}$$

$$\text{and } R_A = \text{Total load} - R_B = (160 + 120) - 130.37 = 149.63 \text{ kN}$$

### S.F. Diagram

$$\text{S.F. at A} = R_A = 149.63 \text{ kN}$$

$$\text{S.F. at C} = 149.63 - 160 = -10.37 \text{ kN}$$

$$\text{S.F. at D} = -10.37 - 120 = -130.37 \text{ kN}$$

$$\text{S.F. at B} = -130.37 \text{ kN}$$

Now S.F. diagram can be drawn as shown in Fig. 15.8(c).

**Problem 15.4.** A fixed beam of length 6 m carries two point loads of 30 kN each at a distance of 2 m from both ends. Determine the fixed end moments and draw the B.M. diagram.

**Sol.** Given :

$$\text{Length, } L = 6 \text{ m}$$

$$\text{Point load at C, } W_1 = 30 \text{ kN}$$

$$\text{Point load at D, } W_2 = 30 \text{ kN}$$

$$\text{Distance } AC = 2 \text{ m}$$

$$\text{Distance } AD = 4 \text{ m}$$

The fixing moment at A due to loads at C and D is given by

$$M_A = \text{Fixing moment due to load at C} + \text{Fixing moment due to load at D}$$

$$= \frac{W_1 a_1 b_1^2}{L^2} + \frac{W_2 a_2 b_2^2}{L^2}$$

$$= \frac{30 \times 2 \times 4^2}{6^2} + \frac{30 \times 4 \times 2^2}{6^2} = \frac{80}{3} + \frac{40}{3} = 40 \text{ kNm.}$$

Since the beam and loading is symmetrical, therefore fixing moments at A and B should be equal.

$$\therefore M_B = M_A = 40 \text{ kNm. Ans.}$$

To draw the B.M. diagram due to vertical loads, consider the beam AB as simply supported. The reactions at the simply supported beam will be equal to 30 kN each.

$$\text{B.M. at A and B} = 0$$

$$\text{B.M. at C} = 30 \times 2 = 60 \text{ kNm}$$

$$\text{B.M. at D} = 30 \times 2 = 60 \text{ kNm.}$$

Now the B.M. diagram due to vertical loads and due to end moments can be drawn as shown in Fig. 15.9 (b).

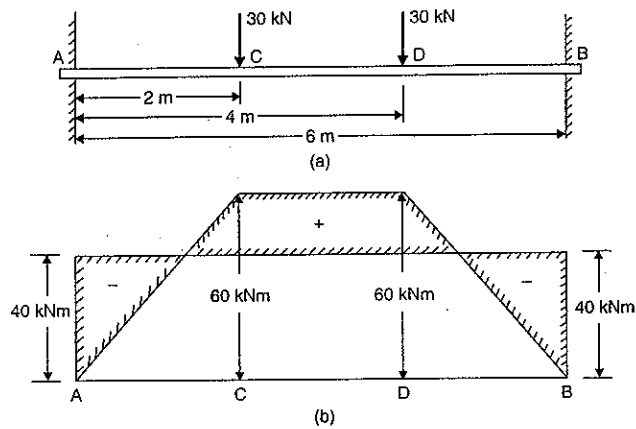

Fig. 15.9

### 15.5. SLOPE AND DEFLECTION FOR A FIXED BEAM CARRYING A UNIFORMLY DISTRIBUTED LOAD OVER THE ENTIRE LENGTH

Fig. 15.10 (a) shows a fixed beam of length  $L$ , carrying uniformly distributed load of  $w$ /unit length over the entire length.

Let  $M_A$  = Fixed end moment at A  
 $M_B$  = Fixed end moment at B  
 $R_A$  = Reaction at A  
 $R_B$  = Reaction at B.

(i) *B.M. Diagram*

Since the loading on the beam is symmetrical, hence  $M_A = M_B$ . The B.M. diagram due to end moments will be a rectangle as shown in Fig. 15.10 (b) by  $AEFB$ . The magnitude of  $M_A$  or  $M_B$  is unknown.

The B.M. diagram for a simply supported beam carrying a uniformly distributed load will be parabola whose central ordinate will be  $wL^2/8$ . The B.M. diagram for this case is shown

in Fig. 15.10 (b) by parabola  $ADB$  in which  $CD = \frac{wL^2}{8}$ .

Equating the areas of the two bending moment diagrams, we get

Area of rectangle  $AEFB$  = Area of parabola  $ADB$

$$AB \times AE = \frac{2}{3} \times [AB \times CD]$$

$$L \times M_A = \frac{2}{3} \times L \times \frac{wL^2}{8} \quad \text{or} \quad M_A = \frac{wL^2}{12}$$

$$\therefore M_B = M_A = \frac{wL^2}{12} \quad \dots(15.9)$$

Now the B.M. diagram can be drawn as shown in Fig. 15.10 (b).

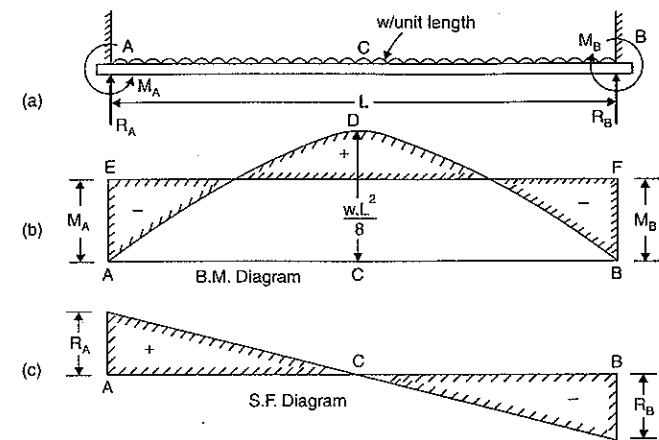

Fig. 15.10

(ii) *S.F. Diagram*

Equating the clockwise moments and anti-clockwise moments about A, we get

$$R_B \times L + M_A = wL \cdot \frac{L}{2} + M_B$$

But  $M_A = M_B$

$$\therefore R_B \times L = wL \cdot \frac{L}{2} \quad \text{or} \quad R_B = \frac{wL}{2}$$

Due to symmetry,

$$R_A = R_B = \frac{wL}{2} \quad \dots(15.10)$$

Now the S.F. diagram can be drawn as shown in Fig. 15.10 (c).

(iii) *Slope and deflection*

The B.M. at any section at a distance  $x$  from A is given by,

$$EI \frac{d^2y}{dx^2} = R_A \times x - M_A - wx \cdot \frac{x}{2}$$

$$= \frac{wL}{2} \cdot x - \frac{wL^2}{12} - \frac{wx^2}{2} \quad \left( \because R_A = \frac{wL}{2}, M_A = \frac{wL^2}{12} \right)$$

$$= \frac{wLx}{2} - \frac{wx^2}{2} - \frac{wL^2}{12} \quad \dots(i)$$

Integrating the above equation, we get

$$EI \frac{dy}{dx} = \frac{wL}{2} \cdot \frac{x^2}{2} - \frac{wx^3}{2 \cdot 3} - \frac{wL^2}{12} \cdot x + C_1$$

$$= \frac{wL}{4} \cdot x^2 - \frac{w}{6} x^3 - \frac{wL^2}{12} \cdot x + C_1$$

where  $C_1$  is a constant of integration.

At  $x = 0$ ,  $\frac{dy}{dx} = 0$ . Hence  $C_1 = 0$ .

Therefore, the above equation becomes as

$$EI \frac{dy}{dx} = \frac{wL}{4} x^2 - \frac{w}{6} x^3 - \frac{wL^2}{12} x \quad \dots(ii)$$

Integrating the above equation, we get

$$\begin{aligned} EIy &= \frac{wL}{4} \cdot \frac{x^3}{3} - \frac{w}{6} \cdot \frac{x^4}{4} - \frac{wL^2}{12} \cdot \frac{x^2}{2} + C_2 \\ &= \frac{wL}{12} x^3 - \frac{w}{24} x^4 - \frac{wL^2}{24} x^2 - C_2 \end{aligned}$$

where  $C_2$  is another constant of integration.

At  $x = 0$ ,  $y = 0$ . Hence  $C_2 = 0$ .

Therefore, the above equation becomes as

$$EIy = \frac{wL}{12} x^3 - \frac{w}{24} x^4 - \frac{wL^2}{24} x^2 \quad \dots(iii)$$

The deflection at the centre is obtained by substituting  $x = \frac{L}{2}$  in the above equation. Let

the deflection at the centre is  $y_c$

$$\begin{aligned} \therefore EIy_c &= \frac{wL}{12} \left(\frac{L}{2}\right)^3 - \frac{w}{24} \left(\frac{L}{2}\right)^4 - \frac{wL^2}{24} \left(\frac{L}{2}\right)^2 \\ &= \frac{wL^4}{96} - \frac{wL^4}{384} - \frac{wL^4}{96} = -\frac{wL^4}{384} \\ \therefore y_c &= -\frac{wL^4}{384EI} \quad \dots(15.11) \end{aligned}$$

Minus sign means that the deflection is downwards.

**Note.** The deflection at the centre of a simply supported beam carrying a uniformly distributed load over the entire length is  $\frac{5}{384} wL^4$ . This means that the central deflection for the fixed beam is one-fifth of the central deflection of the simply supported beam.

(iv) *Points of contraflexures*

For the points of contraflexures, B.M. given by equation (i) should be zero. Hence equating equation (i) to zero, we get

$$\begin{aligned} 0 &= \frac{wLx}{2} - \frac{wx^2}{2} - \frac{wL^2}{12} \\ 0 &= wLx - wx^2 - \frac{wL^2}{6} = Lx - x^2 - \frac{L^2}{6} \end{aligned}$$

$$x^2 - Lx + \frac{L^2}{6} = 0$$

Solving the above quadratic equation, we get

$$x = \frac{L \pm \sqrt{L^2 - \frac{4 \times L^2}{6}}}{2} = \frac{L \pm \sqrt{\frac{L^2}{3}}}{2} = \frac{L}{2} \pm \frac{L}{2\sqrt{3}}$$

As  $L/2$  represents the centre of the beam. Hence the two points of contraflexures occur at a distance of  $L/2\sqrt{3}$  from the centre of the beam.

**Problem 15.5.** A fixed beam of length 5 m carries a uniformly distributed load of 9 kN/m run over the entire span. If  $I = 4.5 \times 10^{-4} \text{ m}^4$  and  $E = 1 \times 10^7 \text{ kN/m}^2$ , find the fixing moments at the ends and the deflection at the centre.

**Sol.** Given :

Length,  $L = 5 \text{ m}$

U.d.l.  $w = 9 \text{ kN/m}$

Value of  $I = 4.5 \times 10^{-4} \text{ m}^4$

Value of  $E = 1 \times 10^7 \text{ kN/m}^2$ .

(i) The fixing moments at the ends is given by equation (15.9) as

$$M_A = M_B = \frac{wL^2}{12} = \frac{9 \times 5^2}{12} = 18.75 \text{ kNm. Ans.}$$

(ii) The deflection at the centre is given by equation (15.11) as

$$\begin{aligned} y_c &= -\frac{wL^4}{384EI} = -\frac{9 \times 5^4}{384 \times 1 \times 10^7 \times 4.5 \times 10^{-4}} \\ &= 0.003254 \text{ m} = -3.254 \text{ mm. Ans.} \end{aligned}$$

**Problem 15.6.** Find the fixing moments and support reactions of a fixed beam AB of length 6 m, carrying a uniformly distributed load of 4 kN/m over the left half of the span.

**Sol.** Given :

Length,  $L = 6 \text{ m}$

U.d.l.,  $w = 4 \text{ kN/m}$

(i) *B.M. diagram due to end moments*

Let  $M_A$  = Fixing moment at A

$M_B$  = Fixing moment at B.

The value of  $M_A$  will be more than  $M_B$  as load due u.d.l. is nearer to point A.

The B.M. diagram due to end moments will be trapezium as shown in Fig. 15.11 (b) by *AEFB*.

The area of B.M. diagram due to end moments is given by,

$$a' = \frac{1}{2} (M_A + M_B) \times 6 = 3(M_A + M_B) \quad \dots(i)$$

(ii) *B.M. diagram due to vertical loads*

Now draw the B.M. diagram due to u.d.l. for a simply supported beam.

Let  $R_A^*$  = Reaction at A for a simply supported beam

$R_B^*$  = Reaction at B for a simply supported beam.

Taking moments about A for a simply supported beam, we get

$$R_B^* \times 6 = 4 \times 3 \times 1.5 = 18$$

$$\therefore R_B^* = \frac{18}{6} = 3 \text{ kN}$$

and

$$\begin{aligned} R_A^* &= \text{Total load} - R_B^* \\ &= 4 \times 3 - 3 = 9 \text{ kN} \end{aligned}$$

The B.M. at A and B are zero.



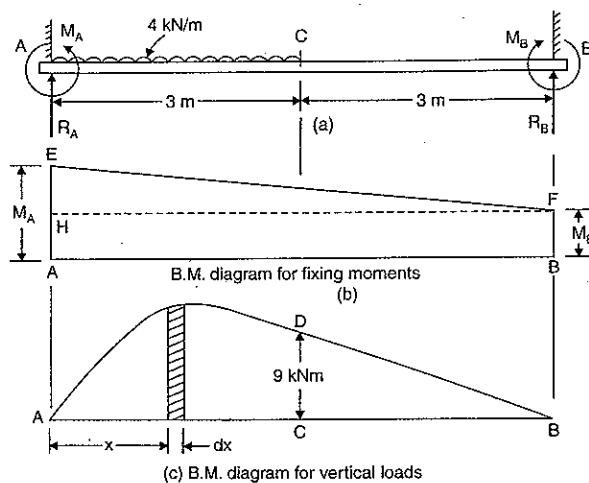

Fig. 15.11

B.M. at  $C = R_B \times 3 = 3 \times 3 = 9 \text{ kNm}$ .

The B.M. diagram from  $A$  to  $C$  will be parabolic and from  $C$  to  $B$  the B.M. diagram will follow a straight line law as shown in Fig. 15.11 (c).

The area of the B.M. due to vertical loads is given by

$$\begin{aligned} a &= \text{Area of parabola } ACD + \text{Area of triangle } BCD \\ &= \text{Area of parabola } ACD + \frac{1}{2} \times 9 \times 3 \end{aligned} \quad \dots(ii)$$

To find the area of the parabola  $ACD$ , consider a strip of length ' $dx$ ' at a distance  $x$  from  $A$  in portion  $AC$ .

The B.M. at a distance  $x$  from  $A$  is given by

$$M_x = R_A \times x - 4 \times x \cdot \frac{x}{2} = 9x - 2x^2 \quad (\because R_A = 9)$$

Area of B.M. diagram of length  $dx$

$$= M_x \cdot dx = (9x - 2x^2) \cdot dx$$

Total area of parabola from  $A$  to  $C$  is obtained by integrating the above equation between the limits of 0 and 3.

$\therefore$  Area of parabola  $ACD$

$$\begin{aligned} &= \int_0^3 (9x - 2x^2) \cdot dx \\ &= \left[ \frac{9x^2}{2} - \frac{2x^3}{3} \right]_0^3 = \frac{9 \times 3^2}{2} - \frac{2 \times 3^3}{3} = 40.5 - 18 = 22.5 \end{aligned}$$

Substituting this value in equation (ii), we get

$$a = 22.5 + \frac{1}{2} \times 9 \times 3 = 36.0 \quad \dots(iii)$$

Equating the two areas given by equations (i) and (iii), we get

$$3(M_A + M_B) = 36.0$$

$$\text{or} \quad M_A + M_B = 12.0 \quad \dots(iv)$$

Now moment of B.M. diagram due to vertical loads about  $A$  is given by

$$\begin{aligned} a\bar{x} &= \int_0^3 x \cdot M_x \cdot dx + \text{Area of triangle } BCD \\ &\quad \times \text{Distance of C.G. of } BCD \text{ from } A \\ &= \int_0^3 x(9x - 2x^2) \cdot dx + \frac{1}{2} \times 9 \times 3 \times \left( 3 + \frac{1}{3} \times 3 \right) \\ &= \int_0^3 (9x^2 - 2x^3) \cdot dx + 54 \\ &= \left[ \frac{9x^3}{3} - \frac{2x^4}{4} \right]_0^3 + 54 = \left[ 3 \times 3^3 - \frac{1}{2} \times 3^4 \right] + 54 \\ &= (81 - 40.5) + 54 = 94.5 \end{aligned} \quad \dots(v)$$

Moment of B.M. diagram due to end moments about  $A$  is given by [see Fig. 15.11 (b)].

$$\begin{aligned} a'\bar{x}' &= \text{Area } ABFH \times \text{Distance of C.G. of } ABFH \text{ from } A \\ &\quad + \text{Area } HFE \times \text{Distance of its C.G. from } A \end{aligned}$$

$$\begin{aligned} &= (M_B \times L) \times \frac{L}{2} + \frac{1}{2} \times L \times (M_A - M_B) \times \frac{1}{3} \times L \\ &= M_B \times 6 \times \frac{6}{2} + \frac{1}{2} \times 6 \times (M_A - M_B) \times \frac{6}{3} \\ &= 18M_B + 6M_A - 6M_B \\ &= 6M_A + 12M_B = 6(M_A + 2M_B) \end{aligned} \quad \dots(vi)$$

$$\text{But} \quad a\bar{x} = a'\bar{x}'$$

$$\therefore \quad 94.5 = 6(M_A + 2M_B)$$

$$\text{or} \quad M_A + 2M_B = \frac{94.5}{6} = 15.75 \quad \dots(vii)$$

Subtracting equation (iv) from (vii), we get

$$M_B = 15.75 - 12.0 = 3.75 \text{ kNm. Ans.}$$

Substituting this value in equation (iv), we get

$$M_A = 12 - 3.75 = 8.25 \text{ kNm. Ans.}$$

*Support reactions*

Let  $R_A$  = Resultant reaction at  $A$

$R_B$  = Resultant reaction at  $B$ .

Equating the anti-clockwise moments and clockwise moments about  $A$ ,

$$R_B \times 6 + M_A = 4 \times 3 \times 1.5 + M_B$$

$$\text{or} \quad R_B \times 6 + 8.25 = 18 + 3.75 = 21.75$$

$$\therefore \quad R_B = \frac{21.75 - 8.25}{6} = \frac{13.50}{6} = 2.25 \text{ kN. Ans.}$$

and

$$\begin{aligned} R_A &= \text{Total load} - R_B \\ &= 4 \times 3 - 2.25 = 9.75 \text{ kN. Ans.} \end{aligned}$$

### Second Method for Problem 15.6

Macaulay's method can be used and directly the fixing moments and end reactions can be calculated. This method is used where the areas of B.M. diagrams cannot be determined conveniently.

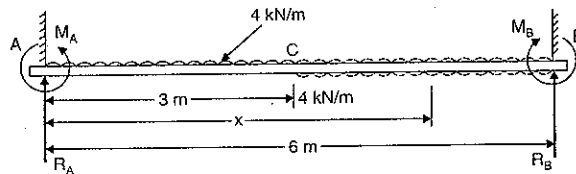

Fig. 15.12

For this method it is necessary that u.d.l. should be extended upto B and then compensated for upward u.d.l. for length BC as shown in Fig. 15.12.

The B.M. at any section at a distance  $x$  from A is given by

$$\begin{aligned} EI \frac{d^2y}{dx^2} &= R_A \cdot x - M_A - w \times x \times \frac{x}{2} + w \times (x-3) \times \frac{(x-3)}{2} \\ &= R_A \cdot x - M_A - \frac{4 \times x^2}{2} + \frac{4(x-3)^2}{2} \\ &= R_A \cdot x - M_A - 2x^2 + 2(x-3)^2 \end{aligned} \quad \dots(A)$$

Integrating, we get

$$EI \frac{dy}{dx} = R_A \cdot \frac{x^2}{2} - M_A \cdot x - \frac{2x^3}{3} + C_1 + \frac{2(x-3)^3}{3} \quad \dots(i)$$

when  $x = 0$ ,  $\frac{dy}{dx} = 0$ .

Substituting this value in the above equation upto dotted line, we get

$$C_1 = 0.$$

Therefore equation (i) becomes as

$$EI \frac{dy}{dx} = R_A \cdot \frac{x^2}{2} - M_A \cdot x - \frac{2x^3}{3} + \frac{2(x-3)^3}{3} \quad \dots(ii)$$

Integrating again, we get

$$EI y = \frac{R_A \cdot x^3}{2 \cdot 3} - \frac{M_A \cdot x^2}{2} - \frac{2x^4}{3 \cdot 4} + C_2 + \frac{2(x-3)^4}{3 \cdot 4} \quad \dots(iii)$$

when  $x = 0$ ,  $y = 0$ .

Substituting this value upto dotted line, we get

$$C_2 = 0$$

Therefore equation (iii) becomes as

$$EI y = \frac{R_A \cdot x^3}{6} - \frac{M_A \cdot x^2}{2} - \frac{1}{6} x^4 + \frac{1}{6} (x-3)^4 \quad \dots(iv)$$

when  $x = 6$ ,  $y = 0$ .

Substituting this value in equation (iv) [Here complete equation is taken], we get

$$\begin{aligned} 0 &= \frac{R_A \times 6^3}{6} - \frac{M_A \times 6^2}{2} - \frac{1}{6} \times 6^4 + \frac{1}{6} \times (6-3)^4 \\ &= 36R_A - 18M_A - 216 + 13.5 \end{aligned}$$

$$\begin{aligned} \text{or} \quad 202.50 &= 36R_A - 18M_A \\ 101.25 &= 18R_A - 9M_A \end{aligned} \quad \dots(v)$$

At  $x = 6$  m,  $\frac{dy}{dx} = 0$ .

Substituting these values in the complete equation (ii), we get

$$\begin{aligned} 0 &= R_A \times \frac{6^2}{2} - M_A \times 6 - \frac{2}{3} \times 6^3 + \frac{2}{3} (6-3)^3 \\ &= 18R_A - M_A \times 6 - 144 + 18 \\ 126 &= 18R_A - 6M_A \end{aligned} \quad \dots(vi)$$

Subtracting equation (v) from equation (vi), we get

$$126 - 101.25 = 9M_A - 6M_A$$

$$\text{or} \quad 24.75 = 3M_A$$

$$\therefore M_A = \frac{24.75}{3} = 8.25 \text{ kNm. Ans.}$$

Substituting this value in equation (vi), we get

$$126 = 18R_A - 6 \times 8.25$$

$$\therefore R_A = \frac{126 + 6 \times 8.25}{18} = 9.75 \text{ kN. Ans.}$$

Now

$$\begin{aligned} R_B &= \text{Total load} - R_A \\ &= 4 \times 3 - 9.75 = 2.25 \text{ kN. Ans.} \end{aligned}$$

To find the value of  $M_B$ , we must equate the clockwise moments and anti-clockwise moments about B. Hence

Clockwise moments about B = Anti-clockwise moments about B.

$$M_B + R_A \times 6 = M_A + 4 \times 3 \times (4.5)$$

$$\text{or} \quad M_B + 9.75 \times 6 = 8.25 + 54 \quad (\because R_A = 9.75 \text{ and } M_A = 8.25)$$

$$\text{or} \quad M_B + 58.50 = 62.25$$

$$\therefore M_B = 62.25 - 58.50 = 3.75 \text{ kNm. Ans.}$$

**Problem 15.7.** A fixed beam of length 20 m, carries a uniformly distributed load of 8 kN/m on the left hand half together with a 120 kN load at 15 m from the left hand end. Find the end reactions and fixing moments and magnitude and the position of the maximum deflection. Take  $E = 2 \times 10^8 \text{ kN/m}^2$  and  $I = 4 \times 10^8 \text{ mm}^4$ .

**Sol.** Given :

Length,  $L = 20 \text{ m}$

U.d.l.,  $w = 8 \text{ kN/m}$

Point load,  $W = 120 \text{ kN}$

Value of  $E = 2 \times 10^8 \text{ kN/m}^2$

Value of  $I = 4 \times 10^8 \text{ mm}^4 = 4 \times 10^{-4} \text{ m}^4$

Lengths,  $AC = 10 \text{ m}$ ,  $AD = 15 \text{ m}$

Fig. 15.13 shows the loading on the fixed beam.

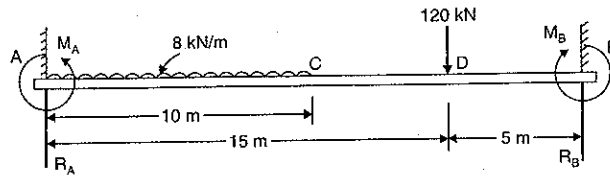

Fig. 15.13

Let  $R_A$  and  $R_B$  = End reactions at A and B

$M_A$  and  $M_B$  = Fixing moments at A and B

Let us apply Macaulay's method for this case. Hence it is necessary that the u.d.l. should be extended upto B and then compensated for upward u.d.l. for length BC as shown in Fig. 15.14.

The B.M. at any section at a distance  $x$  from A is given by,

$$EI \frac{d^2y}{dx^2} = R_A x - M_A - w \times x \times \left(\frac{x}{2}\right) - 120(x-15) + w \times (x-10) \times \left(\frac{x-10}{2}\right)$$

$$= R_A x - M_A - 8 \times \frac{x^2}{2} - 120(x-15) + \frac{8 \times (x-10)^2}{2}$$

$$= R_A x - M_A - 4x^2 - 120(x-15) + 4(x-10)^2$$

Integrating the above equation, we get

$$EI \frac{dy}{dx} = R_A \cdot \frac{x^2}{2} - M_A \cdot x - 4 \cdot \frac{x^3}{3} + C_1 - \frac{120(x-15)^2}{2} + \frac{4(x-10)^3}{3} \quad \dots(i)$$

when  $x=0$ ,  $\frac{dy}{dx} = 0$ . Substituting this value in the above equation upto first dotted line, we get  $C_1 = 0$ . Therefore, equation (i) becomes as

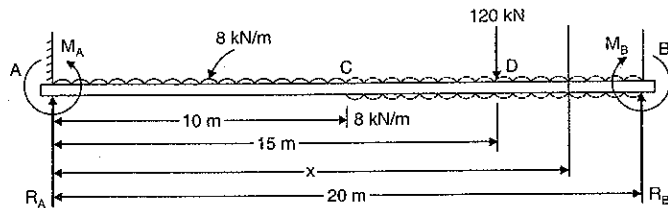

Fig. 15.14

$$EI \frac{dy}{dx} = \frac{R_A}{2} x^2 - M_A x - \frac{4}{3} x^3 - 60(x-15)^2 + \frac{4}{3} (x-10)^3 \quad \dots(ii)$$

Integrating again, we get

$$EIy = \frac{R_A \cdot x^3}{6} - \frac{M_A \cdot x^2}{2} - \frac{4x^4}{3 \times 4} + C_2 - \frac{60(x-15)^3}{3} + \frac{4}{3} \frac{(x-10)^4}{4} \quad \dots(iii)$$

when  $x=0$ ,  $y=0$ . Substituting this value in the above equation upto first dotted line, we get  $C_2 = 0$ . Therefore equation (iii) becomes as

$$EIy = \frac{R_A \cdot x^3}{6} - \frac{M_A \cdot x^2}{2} - \frac{x^4}{3} - 20(x-15)^3 + \frac{1}{3} (x-10)^4 \quad \dots(iv)$$

when  $x=20$ ,  $y=0$ . Substituting these values in complete equation (iv), we get

$$0 = \frac{R_A \times 20^3}{6} - \frac{M_A \times 20^2}{2} - \frac{20^4}{3} - 20(20-15)^3 + \frac{1}{3} (20-10)^4$$

$$= \frac{20}{6} R_A - \frac{M_A}{2} - \frac{20^2}{3} - \frac{125}{20} + \frac{1}{3} \times \frac{10^4}{400} \quad \text{(Dividing by } 20^2)$$

$$= \frac{20}{6} R_A - \frac{M_A}{2} - \frac{400}{3} - \frac{12.5}{2} + \frac{25}{3}$$

$$= \frac{20R_A - 3M_A - 800 - 37.5 + 50}{6}$$

$$\text{or } 20R_A - 3M_A = 800 + 37.5 - 50 = 787.5 \quad \dots(v)$$

At  $x=20$ ,  $\frac{dy}{dx} = 0$ . Substituting these values in complete equation (ii), we get

$$0 = \frac{R_A}{2} \times 20^2 - M_A \times 20 - \frac{4}{3} \times 20^3 - 60(20-15)^2 + \frac{4}{3} (20-10)^3$$

$$= 10R_A - M_A - \frac{4 \times 400}{3} - 3 \times 25 + \frac{4}{3} \times \frac{1000}{20} \quad \text{(Dividing by } 20)$$

$$= 10R_A - M_A - \frac{1600}{3} - 75 + \frac{200}{3}$$

$$\text{or } 10R_A - M_A = \frac{1600}{3} + 75 - \frac{200}{3} = \frac{1400}{3} + 75$$

$$\text{or } 10R_A - M_A = 541.66$$

$$\text{or } 20R_A - 2M_A = 1083.32 \quad \text{(Multiplying by 2 both sides)} \quad \dots(vi)$$

Subtracting equation (v) from equation (vi), we get

$$M_A = 1083.32 - 787.50 = 295.82 \text{ kNm. Ans.}$$

Substituting this values of  $M_A$  in equation (vi), we get

$$20R_A - 2 \times 295.82 = 1083.32$$

$$\therefore R_A = \frac{1083.32 + 2 \times 295.82}{20}$$

$$= 83.748 \text{ kN. Ans.}$$

Now

$$R_B = \text{Total load on beam} - R_A$$

$$= (10 \times 8 + 120) - 83.748 = 116.252 \text{ kN. Ans.}$$

Equating the clockwise moment and anti-clockwise moment about B, we get

$$M_B + R_A \times 20 = M_A + 120 \times 5 + 8 \times 10 \times 15$$

$$\text{or } M_B + 83.748 \times 20 = 295.82 + 600 + 1200$$

$$\text{or } M_B = 2095.82 - 83.748 \times 20 = 420.86 \text{ kNm. Ans.}$$

**Maximum deflection and position of maximum deflection**

Since the point load is more than the total distributed load and acts at an equal distance from the nearest end, hence maximum deflection will be in the portion *AD*. For maximum deflection,  $\frac{dy}{dx}$  should be zero. Substituting the value of  $\frac{dy}{dx} = 0$  in equation (ii) [the term  $-60(x-15)^2$  in equation (ii) should be ignored as this term is for the portion *DB*], we get

$$\begin{aligned} 0 &= \frac{R_A \times x^2}{2} - M_A \cdot x - \frac{4}{3}x^3 + \frac{4}{3}(x-10)^3 \\ &= \frac{83.748}{2} \times x^2 - 295.82x - \frac{4x^3}{3} + \frac{4(x-10)^3}{3} \\ &= 41.874x^2 - 295.82x - \frac{4}{3}x^3 + \frac{4}{3}[x^3 - 1000 - 3x \times 10(x-10)] \\ &= 41.874x^2 - 295.82x - \frac{4000}{3} - \frac{4}{3} \times 3x \times 10 \times x + \frac{4}{3} \times 3x \times 10 \times 10 \\ &= 41.874x^2 - 295.82x - \frac{4000}{3} - 40x^2 + 400x \\ &= 1.874x^2 + 104.18x - 1333.33 \end{aligned}$$

This is a quadratic equation. Hence its solution is

$$\begin{aligned} x &= \frac{-104.18 \pm \sqrt{104.18^2 + 4 \times 1.874 \times 1333.33}}{2 \times 1.874} \\ &= \frac{-104.81 + 144.387}{2 \times 1.874} \quad (\text{Neglecting } -ve \text{ root}) \\ &= 10.727 \text{ m. Ans.} \end{aligned}$$

Hence maximum deflection occurs at a distance of 10.27 m from A. Maximum deflection is obtained by substituting  $x = 10.727$  m in equation (iv) [neglecting the term  $-20(x-15)^3$ ]

$$\begin{aligned} \therefore EIy_{max} &= \frac{R_A \cdot x^2}{6} - \frac{M_A \cdot x^2}{2} - \frac{x^4}{3} + \frac{1}{3}(x-10)^4 \\ &= \frac{83.748 \times 10.727^3}{6} - \frac{295.82 \times 10.727^2}{2} - \frac{10.727^4}{3} + \frac{1}{3}(10.727-10)^4 \\ &= 17228.9 - 17019.8 - 4413.6 + 0.09 \\ &= -4204.5 \\ \therefore y_{max} &= \frac{-4204.5}{EI} = \frac{-4204.5}{2 \times 10^8 \times 4 \times 10^{-4}} \\ &= 0.05255 \text{ m} = 52.56 \text{ mm. Ans.} \end{aligned}$$

**15.6. FIXED END MOMENTS OF FIXED BEAM DUE TO SINKING OF A SUPPORT**

If the ends of a fixed beam are not at the same level, then the support which is at a lower level is known as sinking support. Fig. 15.15 (a) shows a fixed beam *AB* of length *L* whose ends *A* and *B* are fixed at different levels. The end *A* is at a higher level than the end *B*. The beam carries no load. Hence rate of loading on the beam is zero.

Let  $\delta$  = Difference of level between the ends

$M_A$  = Fixing moment at the end *A*

$M_B$  = Fixing moment at the end *B*

$R_A$  = Normal reaction at *A* and

$R_B$  = Normal reaction at *B*.

In this particular case,  $M_A$  is a negative (hogging) and  $M_B$  is a positive moment. Numerically  $M_A$  and  $M_B$  are equal.

$$\begin{aligned} \text{We know that } EI \frac{d^4 y}{dx^4} &= \text{Rate of loading} \\ &= 0 \end{aligned}$$

$$\text{Integrating, we get } EI \frac{d^3 y}{dx^3} = C_1 \quad \dots(i)$$

where  $C_1$  is a constant of integration. And  $EI \frac{d^3 y}{dx^3}$  represents the shear force. At  $x = 0$ , S.F. is equal to  $R_A$ . Hence  $EI \frac{d^3 y}{dx^3}$  (at  $x = 0$ ) is  $R_A$ .

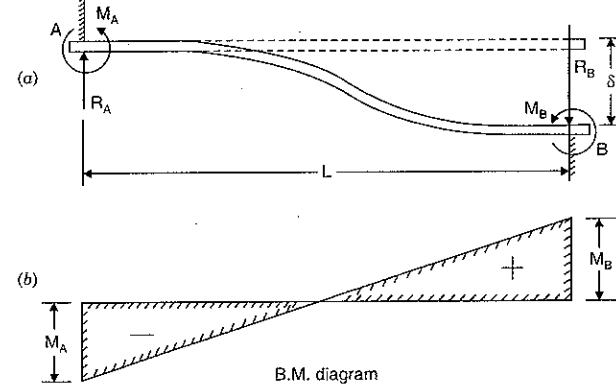

B.M. diagram

Fig. 15.15

Substituting this value in equation (i), we get

$$R_A = C_1$$

$\therefore$  Equation (i) becomes as

$$EI \frac{d^3 y}{dx^3} = R_A$$

Integrating again, we get

$$EI \frac{d^2 y}{dx^2} = R_A \cdot x + C_2 \quad \dots(ii)$$

where  $C_2$  is another constant of integration. And  $EI \frac{d^2 y}{dx^2}$  represents the B.M. at  $x = 0$ , B.M. is equal to  $-M_A$ .

$$\text{Hence at } x = 0, EI \frac{d^2 y}{dx^2} = -M_A.$$

Substituting  $x = 0$  and  $EI \frac{d^2y}{dx^2} = -M_A$  in equation (ii), we get

$$-M_A = R_A \times 0 + C_2$$

or

$$C_2 = -M_A$$

Substituting  $C_2$  in equation (ii), we get

$$EI \frac{d^2y}{dx^2} = R_A x - M_A \quad \dots(A)$$

Integrating the above equation again, we get

$$EI \frac{dy}{dx} = R_A \cdot \frac{x^2}{2} - M_A x + C_3$$

where  $C_3$  is another constant of integration. At  $x = 0$ ,  $\frac{dy}{dx} = 0$ .

Hence  $C_3 = 0$ .

Therefore the above equation becomes as

$$EI \frac{dy}{dx} = \frac{R_A x^2}{2} - M_A x \quad \dots(iii)$$

Integrating again, we get

$$EI y = \frac{R_A}{2} \cdot \frac{x^3}{3} - M_A \cdot \frac{x^2}{2} + C_4$$

where  $C_4$  is a constant of integration. At  $x = 0$ ,  $y = 0$ . Hence  $C_4 = 0$ . Therefore the above equation becomes as

$$EI y = \frac{R_A}{6} x^3 - \frac{M_A}{2} x^2 \quad \dots(iv)$$

At  $x = L$ ,  $y = -\delta$ . Hence the above equation becomes as

$$-EI\delta = \frac{R_A}{6} L^3 - \frac{M_A}{2} L^2 \quad \dots(v)$$

At  $x = L$ ,  $\frac{dy}{dx} = 0$ . Substituting these values in equation (iii), we get

$$0 = \frac{R_A}{2} L^2 - M_A L$$

$$R_A = \frac{2M_A}{L} \quad \dots(vi)$$

Substituting the value of  $R_A$  in equation (v), we get

$$-EI\delta = \frac{2M_A}{6L} L^3 - \frac{M_A}{2} L^2$$

$$= \frac{M_A L^2}{3} - \frac{M_A L^2}{2} = \frac{2M_A L^2 - 3M_A L^2}{6}$$

$$= -\frac{1}{6} M_A L^2$$

$$\therefore M_A = \frac{6EI\delta}{L^2}$$

Now the B.M. at any section at a distance  $x$  from  $A$  is given by equation (A) as

$$EI \frac{d^2y}{dx^2} = R_A x - M_A$$

$$= \frac{2M_A}{L} x - M_A \quad \left( \because R_A = \frac{2M_A}{L} \right)$$

$$= \frac{2}{L} \times \frac{6EI\delta}{L^2} x - \frac{6EI\delta}{L^2} \quad \left( \because M_A = \frac{6EI\delta}{L^2} \right)$$

$$= \frac{12EI\delta}{L^3} x - \frac{6EI\delta}{L^2}$$

At  $x = L$ ,  $EI \frac{d^2y}{dx^2}$  represents B.M. at  $B$  i.e.,  $EI \frac{d^2y}{dx^2} = M_B$ . Hence the above equation becomes as

$$M_B = \frac{12EI\delta}{L^3} \times L - \frac{6EI\delta}{L^2}$$

$$= \frac{12EI\delta}{L^2} - \frac{6EI\delta}{L^2} = \frac{6EI\delta}{L^2}$$

Hence numerically  $M_A = M_B = \frac{6EI\delta}{L^2}$ . This means that if the ends of a fixed beam are at

different levels (or one end sinks down by an amount  $\delta$  with respect to other end), the fixing moment at each end is equal. At the higher end, this moment is a hogging moment and at the lower end this moment is a sagging moment. The B.M. diagram is shown in Fig. 15.15 (b).

**Problem 15.8.s** A fixed beam  $AB$  of length 3 m is having moment of inertia  $I = 3 \times 10^6 \text{ mm}^4$ . The support  $B$  sinks down by 3 mm. If  $E = 2 \times 10^5 \text{ N/mm}^2$ , find the fixing moments.

**Sol.** Given :

Length,  $L = 3 \text{ m} = 3000 \text{ mm}$

Value of  $I = 3 \times 10^6 \text{ mm}^4$

Value of  $E = 2 \times 10^5 \text{ N/mm}^2$

The amount by which the support  $B$  sinks down,

$$\delta = 3 \text{ mm.}$$

The fixing moments at the ends is given by,

$$M_A = M_B = \frac{6EI\delta}{L^2}$$

$$= \frac{6 \times 2 \times 10^5 \times 3 \times 10^6 \times 3}{3000^2}$$

$$= 12 \times 10^5 \text{ Nmm} = 12 \times 10^3 \text{ Nm} = 12 \text{ kNm. Ans.}$$

The fixing moment at  $A$  will be a hogging moment whereas at  $B$  it will be a sagging moment.

## 15.7. ADVANTAGES OF FIXED BEAMS

The following are the advantages of a fixed beam over a simply supported beam :

(i) For the same loading, the maximum deflection of a fixed beam is less than that of a simply supported beam.

(ii) For the same loading, the fixed beam is subjected to a lesser maximum bending moment.

(iii) The slope at both ends of a fixed beam is zero.

(iv) The beam is more stable and stronger.

15.8. CONTINUOUS BEAMS

Continuous beam is a beam which is supported on more than two supports. Fig. 15.16 shows such a beam, which is subjected to some external loading (here a uniformly distributed load). The deflection curve for the beam is shown by dotted line. The deflection curve is having convexity upwards over the intermediate supports, and concavity upwards over the mid of the span. Hence there will be hogging moments (i.e., negative) over the intermediate supports and sagging moments (i.e., positive) over the mid of the span. The end supports of a simply supported continuous beam will not be subjected to any bending moment. But the end support of fixed continuous beam will be subjected to fixing moments. If the moments over the intermediate supports are known, then the B.M. diagram can be drawn.

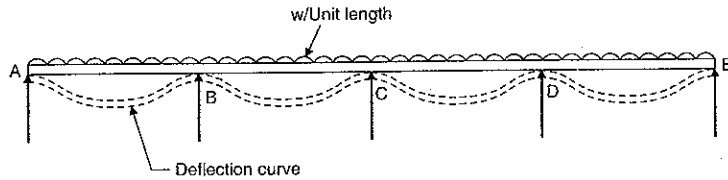

Fig. 15.16

The Fig. 15.16 shows a simply supported continuous beam. In this figure the end supports at A and E will not be subjected to any bending moment. Hence in this case  $M_A = M_E = 0$ .

Fig. 15.16 (a) shows a continuous beam with fixed ends at A and E. Here the end supports at A and E will be subjected to fixing moments. Hence  $M_A$  and  $M_E$  will not be zero.

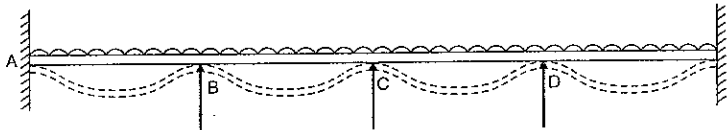

Fig. 15.16 (a)

15.9. BENDING MOMENT DIAGRAM FOR CONTINUOUS BEAMS

In Art. 15.8 it is mentioned that if the moments over the intermediate supports of a continuous beam are known, then the B.M. diagram can be drawn easily. The moments over the intermediate supports are determined by using *Clapeyron's theorem of three moments* which states that :

If BC and CD are any two consecutive span of a continuous beam subjected to an external loading, then the moments  $M_B, M_C$  and  $M_D$  at the supports B, C and D are given by,

$$M_B L_1 + 2M_C(L_1 + L_2) + M_D L_2 = \frac{6a_1 \bar{x}_1}{L_1} + \frac{6a_2 \bar{x}_2}{L_2} \quad \dots(15.12)$$

- where  $L_1$  = Length of span BC  
 $L_2$  = Length of span CD  
 $a_1$  = Area of B.M. diagram due to vertical loads on span BC  
 $a_2$  = Area of B.M. diagram due to vertical loads on span CD

- $\bar{x}_1$  = Distance of C.G. of the B.M. diagram due to vertical loads on BC from B  
 $\bar{x}_2$  = Distance of C.G. of the B.M. diagram due to vertical loads on CD from D.

The equation (15.12) is known as the *equation of three moments* or *Clapeyron's equation*.

**15.9.1. Derivation of Clapeyron's Equation of three Moments.** Fig. 15.17 shows the length BCD (two consecutive spans) of a continuous beam which is shown in Fig. 15.16. Let  $M_B, M_C$  and  $M_D$  are the support moments at B, C and D respectively.

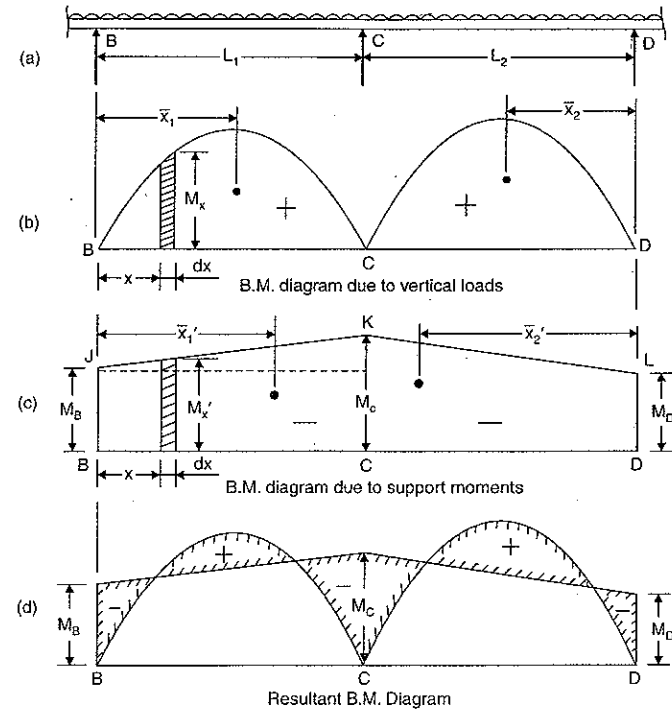

Fig. 15.17

- Let  $L_1$  = Length of span BC  
 $L_2$  = Length of span CD  
 $a_1$  = Area of B.M. diagram due to vertical loads on span BC  
 $a_2$  = Area of B.M. diagram due to vertical loads on span CD  
 $a_1'$  = Area of B.M. diagram due to support moments  $M_B$  and  $M_C$   
 $a_2'$  = Area of B.M. diagram due to support moments  $M_C$  and  $M_D$   
 $\bar{x}_1$  = Distance of C.G. of B.M. diagram due to vertical loads on BC  
 $\bar{x}_2$  = Distance of C.G. of B.M. diagram due to vertical loads on CD  
 $\bar{x}_1'$  = Distance of C.G. of B.M. diagram due to support moments on BC  
 $\bar{x}_2'$  = Distance of C.G. of B.M. diagram due to support moments on CD.

Fig. 15.17 (b) and (c) shows the B.M. diagrams due to vertical loads and due to supports moments respectively.

(i) Consider the span BC

Let  $M_x$  = B.M. due to vertical loads at a distance  $x$  from  $B$  (sagging)

$M_x'$  = B.M. due to support moments at a distance  $x$  from  $B$  (hogging)

∴ Net B.M. at a distance  $x$  from  $B$  is given by,

$$EI \frac{d^2 y}{dx^2} = M_x - M_x'$$

Multiplying by  $x$  to both sides, we get

$$EI x \frac{d^2 y}{dx^2} = x M_x - x M_x'$$

Integrating from zero to  $L_1$ , we get

$$\int_0^{L_1} EI x \frac{d^2 y}{dx^2} dx = \int_0^{L_1} x M_x dx - \int_0^{L_1} x M_x' dx$$

or

$$EI \left[ x \frac{dy}{dx} - y \right]_0^{L_1} = a_1 \bar{x}_1 - a_1' \bar{x}_1' \quad \dots(i)$$

(∵  $M_x dx$  = Area of B.M. diagram of length  $dx$ . And  $x M_x dx$  = Moment of area of B.M. diagram of length  $dx$  about  $B$ .)

Hence  $\int_0^{L_1} x M_x dx = a_1 \bar{x}_1$ . And so on)

Substituting the limits in L.H.S. of equation (i), we have

$$EI \left[ \left\{ L_1 \left( \frac{dy}{dx} \right)_{at C} - y_C \right\} - \left\{ 0 \times \left( \frac{dy}{dx} \right)_{at B} - y_B \right\} \right] = a_1 \bar{x}_1 - a_1' \bar{x}_1'$$

or

$$EI[(L_1 \theta_C - y_C) - (0 - y_B)] = a_1 \bar{x}_1 - a_1' \bar{x}_1' \quad \left[ \because \left( \frac{dy}{dx} \right)_{at C} = \theta_C \right]$$

But deflection at  $B$  and  $C$  are zero. Hence  $y_B = 0$  and  $y_C = 0$ . Hence above equation becomes as

$$[EI L_1 \theta_C = a_1 \bar{x}_1 - a_1' \bar{x}_1'] \quad \dots(ii)$$

But  $a_1'$  = Area of B.M. diagram due to supports moments

= Area of trapezium  $BCKJ$

$$= \frac{1}{2}(M_B + M_C) \times L_1$$

and

$\bar{x}_1'$  = Distance of C.G. of area  $BCKJ$  from  $B$

$$= \frac{M_B \cdot L_1 \cdot \frac{L_1}{2} + \frac{1}{2} \times (M_C - M_B) \cdot L_1 \times \frac{2L_1}{3}}{M_B \cdot L_1 + \frac{1}{2}(M_C - M_B) \cdot L_1}$$

$$= \frac{M_B \cdot \frac{L_1}{2} + (M_C - M_B) \times \frac{L_1}{3}}{M_B + (M_C - M_B) \cdot \frac{1}{2}} = \frac{3M_B L_1 + 2L_1(M_C - M_B)}{2M_B + M_C - M_B} = \frac{3M_B L_1 + 2L_1(M_C - M_B)}{2M_B + M_C - M_B}$$

$$= \frac{L_1}{3} [3M_B + 2M_C - 2M_B] = \left( \frac{M_B + 2M_C}{M_B + M_C} \right) \times \frac{L_1}{3}$$

Substituting the values of  $\bar{a}_1$  and  $\bar{x}_1'$  in equation (ii), we get

$$EI L_1 \theta_C = a_1 \bar{x}_1 - \frac{1}{2}(M_B + M_C) \cdot L_1 \times \left( \frac{M_B + 2M_C}{M_B + M_C} \right) \times \frac{L_1}{3} = a_1 \bar{x}_1 - \frac{L_1^2}{6}(M_B + 2M_C)$$

or

$$6EI \theta_C = \frac{6a_1 \bar{x}_1}{L_1} - L_1(M_B + 2M_C) \quad \dots(iii)$$

(ii) Consider the span CD

Similarly considering the span  $CD$  and taking  $D$  as origin and  $x$  positive to the left, it can be shown that

$$6EI(-\theta_C) = \frac{6a_2 \bar{x}_2}{L_2} - L_2(M_D + 2M_C)$$

[In the above case the slope at  $C$  (i.e.,  $\theta_C$ ) will have opposite sign than that given by equation (iii). The reason is that the direction of  $x$  from  $B$  for the span  $BC$ , and from  $D$  for span  $CD$  are in the opposite direction].

Hence the above equation becomes as

$$\therefore -6EI\theta_C = \frac{6a_2 \bar{x}_2}{L_2} - L_2(M_D + 2M_C) \quad \dots(iv)$$

Adding equation (iii) and (iv), we get

$$0 = \frac{6a_1 \bar{x}_1}{L_1} - L_1(M_B + 2M_C) + \frac{6a_2 \bar{x}_2}{L_2} - L_2(M_D + 2M_C) = \frac{6a_1 \bar{x}_1}{L_1} + \frac{6a_2 \bar{x}_2}{L_2} - L_1 M_B - 2L_1 M_C - L_2 M_D - 2L_2 M_C$$

or

$$L_1 M_B + L_2 M_D + 2M_C(L_1 + L_2) = \frac{6a_1 \bar{x}_1}{L_1} + \frac{6a_2 \bar{x}_2}{L_2}$$

or

$$M_B L_1 + 2M_C(L_1 + L_2) + M_D L_2 = \frac{6a_1 \bar{x}_1}{L_1} + \frac{6a_2 \bar{x}_2}{L_2}$$

**15.9.2. Application of Clapeyron's equation of Three Moments to Continuous Beam with Simply Supported ends.** The fixing moments on the ends of a simply supported beam is zero. The continuous beam with simply supported ends may carry uniformly distributed load or point loads as given in the following problems:

**Problem 15.9.** A continuous beam  $ABC$  covers two consecutive span  $AB$  and  $BC$  of lengths 4 m and 6 m, carrying uniformly distributed loads of 6 kN/m and 10 kN/m respectively. If the ends  $A$  and  $C$  are simply supported, find the support moments at  $A$ ,  $B$  and  $C$ . Draw also B.M. and S.F. diagrams.

**Sol.** Given :

Length  $AB$ ,  $L_1 = 4$  m

Length  $BC$ ,  $L_2 = 6$  m

U.d.l. on AB,  $w_1 = 6 \text{ kN/m}$

U.d.l. on BC,  $w_2 = 10 \text{ kN/m}$

Since the ends A and C are simply supported, the support moments at A and C will be zero.

$$M_A = M_C = 0$$

To find the support moment at B (i.e.,  $M_B$ ), Clapeyron's equation of three moments should be applied. Hence, we get

$$M_A L_1 + 2M_B(L_1 + L_2) + M_C L_2 = \frac{6a_1 \bar{x}_1}{L_1} + \frac{6a_2 \bar{x}_2}{L_2}$$

$$0 \times 4 + 2M_B(4 + 6) + 0 \times L_2 = \frac{6a_1 \bar{x}_1}{4} + \frac{6a_2 \bar{x}_2}{6}$$

$$20M_B = \frac{3a_1 \bar{x}_1}{2} + a_2 \bar{x}_2 \quad \dots(i)$$

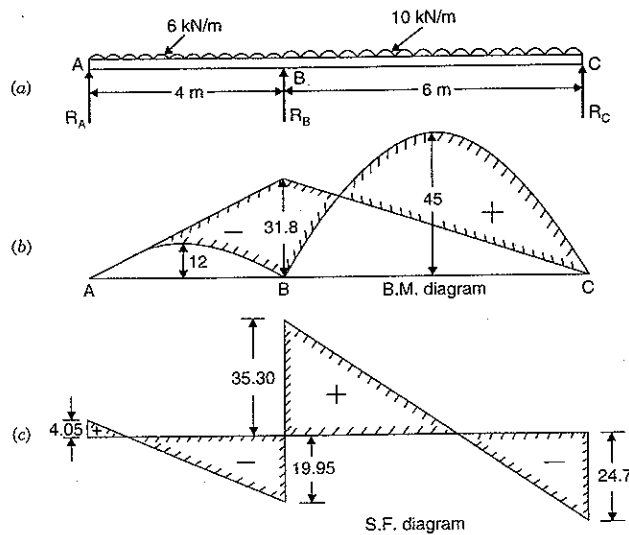

Fig. 15.18

The B.M. diagram on a simply supported beam carrying u.d.l. is a parabola having an altitude of  $\frac{wL^2}{8}$ . And area of B.M. diagram =  $\frac{2}{3} \times \text{Span} \times \text{Altitude}$ . The distance of C.G. of this

area from one end =  $\frac{\text{Span}}{2}$ .

Now  $a_1 = \text{Area of B.M. diagram due to u.d.l. on AB}$

$$= \frac{2}{3} \times AB \times \text{Altitude} = \frac{2}{3} \times AB \times \frac{w_1 L_1^2}{8}$$

$$= \frac{2}{3} \times 4 \times \frac{6 \times 4^2}{8} = 32$$

$$\bar{x}_1 = \frac{L_1}{2} = \frac{4}{2} = 2 \text{ m}$$

$a_2 = \text{Area of B.M. diagram due to u.d.l. on BC}$

$$= \frac{2}{3} \times BC \times \frac{w_2 L_2^2}{8} = \frac{2}{3} \times 6 \times \frac{10 \times 6^2}{8} = 180$$

$$\text{and } \bar{x}_2 = \frac{L_2}{2} = \frac{6}{2} = 3 \text{ m.}$$

Substituting these values in equation (i), we get

$$20M_B = \frac{3 \times 32 \times 2}{2} + 180 \times 3$$

$$= 96 + 540 = 636$$

$$\therefore M_B = \frac{636}{20} = 31.8 \text{ kNm.}$$

Now B.M. diagram due to supports moments is drawn as shown in Fig. 15.18 (b) in which

$$M_A = 0, M_C = 0 \text{ and } M_B = 31.8 \text{ kNm.}$$

The B.M. diagram due to vertical loads (here u.d.l.) on span AB and span BC are also shown by parabolas of altitudes

$$\frac{w_1 L_1^2}{8} = \frac{6 \times 4^2}{8} = 12 \text{ kNm and } \frac{w_2 L_2^2}{8} = \frac{10 \times 6^2}{8} = 45 \text{ kNm}$$

respectively in Fig. 15.18 (b).

#### S.F. Diagram

First calculate the reactions  $R_A$ ,  $R_B$  and  $R_C$  at A, B and C respectively. For the span AB, taking moments about B, we get

$$R_A \times 4 - 6 \times 4 \times \frac{4}{2} = M_B \quad (\text{The support B has moment } M_B)$$

$$= -31.8$$

or

$$(\because M_B = 31.8. \text{ Negative sign is taken as the moment at B is hogging})$$

$$4R_A - 48 = -31.8$$

or

$$R_A = \frac{-31.8 + 48}{4} = 4.05 \text{ kN.}$$

Similarly for the span BC, taking moments about B, we get

$$R_C \times 6 - 6 \times 10 \times \frac{6}{2} = M_B = -31.8$$

or

$$6R_C - 180 = -31.8$$

or

$$R_C = \frac{180 - 31.8}{6} = 24.7 \text{ kN.}$$

Now

$$R_B = \text{Total load on ABC} - (R_A + R_C)$$

$$= (6 \times 4 + 10 \times 6) - (4.05 + 24.7) = 55.25 \text{ kN.}$$

Now complete the S.F. diagram as shown in Fig. 15.18 (c).



**Problem 15.10.** A continuous beam ABCD of length 15 m rests on four supports covering 3 equal spans and carries a uniformly distributed load of 1.5 kN/m length. Calculate the moments and reactions at the supports. Draw the S.F. and B.M. diagrams also.

**Sol. Given :**

Length AB,  $L_1 = 5$  m

Length BC,  $L_2 = 5$  m

Length CD,  $L_3 = 5$  m

U.d.l.,  $w_1 = w_2 = w_3 = 1.5$  kN/m.

Since ends A and D are simply supported, the support moments at A and D will be zero.

$\therefore M_A = 0$  and  $M_D = 0$

From symmetry  $M_B = M_C$

To find the support moments at B and D, Clapeyron's equation of three moments is applied for ABC and for BCD.

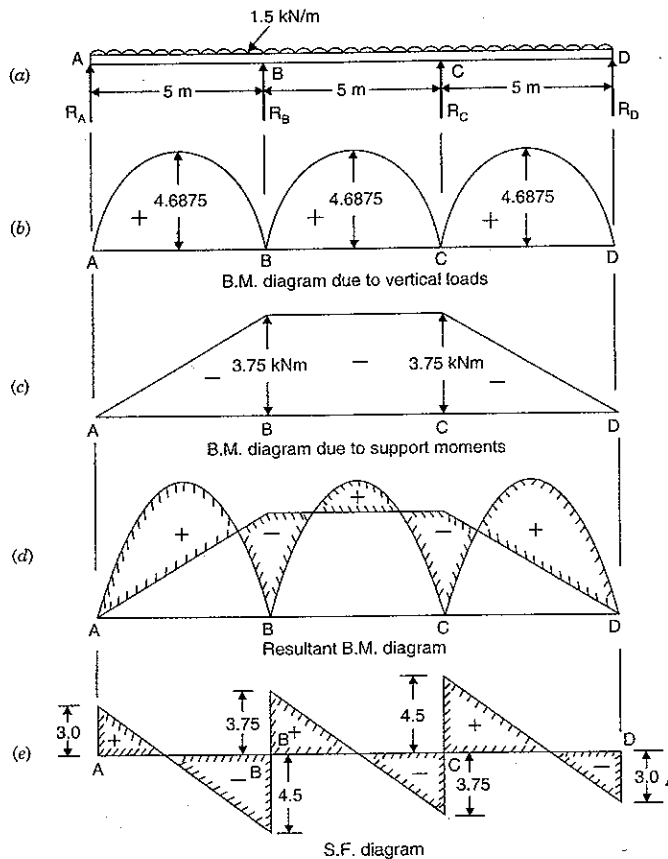

Fig. 15.19

For ABC, we get

$$M_A L_1 + 2M_B(L_1 + L_2) + M_C \cdot L_2 = \frac{6a_1 \bar{x}_1}{L_1} + \frac{6a_2 \bar{x}_2}{L_2}$$

or  $0 \times 5 + 2M_B(5 + 5) + M_C \times 5 = \frac{6a_1 \bar{x}_1}{5} + \frac{6a_2 \bar{x}_2}{5}$

or  $20M_B + 5M_C = \frac{6}{5} (a_1 \bar{x}_1 + a_2 \bar{x}_2) \dots(i)$

Now  $a_1$  = Area of B.M. Diagram due to u.d.l. on AB when AB is considered as simply supported beam

$$= \frac{2}{3} \times AB \times \text{Altitude of parabola}$$

$$= \frac{2}{3} \times 5 \times \frac{w_1 L_1}{8} = \frac{2}{3} \times 5 \times \frac{15 \times 5^2}{8} = 15.625$$

$$\bar{x}_2 = \frac{L_1}{2} = \frac{5}{2} = 2.5 \text{ m}$$

Due to symmetry  $a_2 = a_1 = 15.625$  and  $\bar{x}_2 = \bar{x}_1 = 2.5$

Substituting these values in equation (i), we get

$$20M_B + 5M_C = \frac{6}{5} (15.625 \times 2.5 + 15.625 \times 2.5)$$

$$= \frac{6}{5} \times 2 \times 15.625 \times 2.5 = 93.750$$

or  $20M_B + 5M_B = 93.750 \quad (\because M_B = M_C \text{ due to symmetry})$

or  $M_B = \frac{93.750}{25} = 3.75 \text{ kNm}$

$\therefore M_B = M_C = 3.75 \text{ kNm. Ans.}$

Now the B.M. diagram due to supports moments is drawn as shown in Fig. 15.19 (c), in which

$$M_A = 0, M_D = 0, M_B = M_C = 3.75 \text{ kNm.}$$

The B.M. diagram due to vertical loads (here u.d.l.) on span AB, BC and CD (considering each span as simply supported) are shown by parabolas of altitudes  $\frac{w_1 L_1^2}{8} = \frac{15 \times 5^2}{8} = 4.6875 \text{ kNm}$  each in Fig. 15.19 (b). Resultant B.M. diagram is shown in Fig. 15.19 (d).

**Support Reactions**

Let  $R_A, R_B, R_C$  and  $R_D$  are the support reactions at A, B, C and D respectively.

Due to symmetry,  $R_A = R_D$

$$R_B = R_C$$

For the span AB, taking moments about B, we get

$$M_B = R_A \times 5 - 1.5 \times 5 \times \frac{5}{2}$$

or  $-3.75 = R_A \times 5 - 18.75 \quad (\because M_B = -3.75)$

or  $5R_A = 18.75 - 3.75 = 15$

$\therefore R_A = \frac{15}{5} = 3.0 \text{ kN. Ans.}$

∴ Due to symmetry,  $R_D = R_A = 3.0 \text{ kN}$ . Ans.

Now  $R_A + R_B + R_C + R_D = \text{Total load on } ABCD$

$$R_A + R_B + R_B + R_A = 1.5 \times 15$$

$$(\because R_C = R_B, R_D = R_A)$$

$$2(R_A + R_B) = 22.5$$

$$R_A + R_B = \frac{22.5}{2} = 11.25$$

$$R_B = 11.25 - R_A = 11.25 - 3.00 = 8.25$$

$$(\because R_A = 3.0)$$

$$R_B = R_C = 8.25 \text{ kN. Ans.}$$

Now the S.F. diagram can be drawn as shown in Fig. 15.19 (e).

**Problem 15.11.** A continuous beam ABCD, simply supported at A, B, C and D is loaded as shown in Fig. 15.20 (a). Find the moments over the beam and draw B.M. and S.F. diagrams.

Sol. Given :

Length AB,  $L_1 = 6 \text{ m}$

Length BC,  $L_2 = 5 \text{ m}$

Length CD,  $L_3 = 4 \text{ m}$

Point load in BD,  $W_1 = 9 \text{ kN}$

Point load in BC,  $W_2 = 8 \text{ kN}$

U.d.l. on CD,  $w = 3 \text{ kN/m}$ .

(i) B.M. diagram due to vertical loads taking each span as simply supported

Consider beam AB as simply supported

$$\begin{aligned} \text{B.M. at point load at } E &= \frac{W_1 \times a \times b}{L_1} = \frac{9 \times 2 \times 4}{6} \quad (\because \text{Here } a = 2 \text{ m, } b = 4 \text{ m}) \\ &= 12 \text{ kNm} \end{aligned}$$

Similarly B.M. at F, considering beam BC as simply supported

$$\begin{aligned} &= \frac{W_2 \cdot a \cdot b}{L_2} = \frac{8 \times 2 \times 3}{5} \quad (\because \text{Here } a = 2, b = 3 \text{ and } L_2 = 5) \\ &= 9.6 \text{ kNm} \end{aligned}$$

The B.M. at the centre of a simply supported beam CD, carrying u.d.l.

$$= \frac{w \times L_3^2}{8} = \frac{3 \times 4^2}{8} = 6 \text{ kNm.}$$

Now the B.M. diagram due to vertical loads taking each span as simply supported can be drawn as shown in Fig. 15.20 (b).

(ii) B.M. diagram due to support moments

Let  $M_A, M_B, M_C$  and  $M_D$  are the supports moments at A, B, C and D respectively. But the end supports of a simply supported beam are not subjected to any bending moment. Hence the support moments at A and D will be zero.

$$\therefore M_A = 0 \text{ and } M_D = 0$$

To find the support moments at B and C, Clapeyron's equation of three moments is applied for ABC and for BCD.

(a) For spans AB and BC from equation of three moments, we have

$$M_A \cdot L_1 + 2M_B(L_1 + L_2) + M_C \cdot L_2 = \frac{6a_1\bar{x}_1}{L_1} + \frac{6a_2\bar{x}_2}{L_2}$$

or

$$0 + 2M_B(6 + 5) + M_C \times 5 = \frac{6a_1\bar{x}_1}{6} + \frac{6a_2\bar{x}_2}{5}$$

or

$$22M_B + 5M_C = a_1\bar{x}_1 + \frac{6}{5}a_2\bar{x}_2 \quad \dots(i)$$

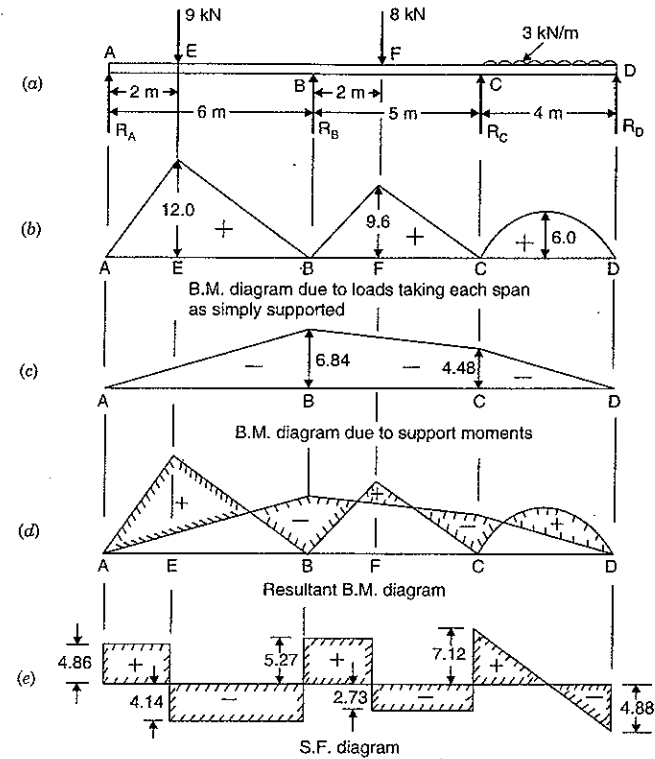

Fig. 15.20

Now

$a_1\bar{x}_1 = \text{Moment of area of B.M. diagram due to vertical load on AB when AB is considered as simply supported beam about point A.}$

$$\begin{aligned} &= \frac{1}{2} \times 2 \times 12 \times \frac{2 \times 2}{3} + \frac{1}{2} \times 4 \times 12 \times \left(2 + \frac{1}{3} \times 4\right) \\ &= 16 + 80 = 96 \end{aligned}$$

$a_2\bar{x}_2 = \text{Moment of area of B.M. diagram due to vertical load on BC when BC is considered as simply supported beam about point C}$

$$\begin{aligned} &= \frac{1}{2} \times 3 \times 9.6 \times \frac{2}{3} \times 3 + \frac{1}{2} \times 2 \times 9.6 \times \left(3 + \frac{1}{3} \times 2\right) \\ &= 28.8 + 35.2 = 64.0 \end{aligned}$$

Substituting these values in equation (i), we get

$$22M_B + 5M_C = 96 + \frac{6}{5} \times 64 = 172.8 \quad \dots(ii)$$

(b) For spans BC and CD from equation of three moments, we have

$$M_B \cdot L_2 + 2M_C(L_2 + L_3) + M_D \cdot L_3 = \frac{6a_2\bar{x}_2}{L_2} + \frac{6a_3\bar{x}_3}{L_3}$$

or  $M_B \times 5 + 2M_C(5 + 4) + 0 = \frac{6a_2\bar{x}_2}{5} + \frac{6a_3\bar{x}_3}{4} \quad (\because M_D = 0)$

or  $5M_B + 18M_C = \frac{6}{5}a_2\bar{x}_2 + \frac{6}{5}a_3\bar{x}_3 \quad \dots(iii)$

where  $a_2\bar{x}_2$  = Moment of area of B.M. diagram due to vertical load on BC when BC is considered as simply supported beam, about point B

$$= \frac{1}{2} \times 2 \times 9.6 \times \frac{2}{3} \times 2 + \frac{1}{2} \times 3 \times 9.6 \times \left(2 + \frac{1}{3} \times 3\right) = 12.8 + 43.2 = 56.0$$

and  $a_3\bar{x}_3$  = Moment of area of B.M. diagram due to u.d.l. on CD, when CD is considered as simply supported beam, about point D

$$= \left(\frac{2}{3} \times \text{Base} \times \text{Altitude}\right) \times \frac{\text{Base}}{2} = \frac{2}{3} \times 4 \times 6 \times \frac{4}{2} = 32$$

Substituting these values in equation (iii), we get

$$5M_B + 18M_C = \frac{6}{5} \times 56 + \frac{6}{4} \times 32 = 115.2 \quad \dots(iv)$$

Solving equations (ii) and (iv), we get

$$M_B = 6.84 \text{ kNm} \quad \text{and} \quad M_C = 4.48 \text{ kNm.}$$

Now the B.M. diagram due to supports moments is drawn as shown in Fig. 15.20 (c), in which

$$M_A = 0, M_B = 6.84, M_C = 4.48 \text{ and } M_D = 0.$$

The B.M. diagram due to supports moments will be negative. Resultant B.M. diagram is shown in Fig. 15.20 (d).

(iii) Support Reactions

Let  $R_A, R_B, R_C$  and  $R_D$  are the support reactions at A, B, C and D respectively,

For the span AB, taking moments about B, we get

$$M_B = R_A \times 6 - 9 \times 4$$

or  $-6.84 = 6R_A - 36 \quad (\because M_B = -6.84)$

or  $R_A = \frac{36 - 6.84}{6} = 4.86 \text{ kN. Ans.}$

For the span CD, taking moments about C, we get

$$M_C = R_D \times 4 - 3 \times 4 \times \frac{4}{2}$$

or  $-4.48 = 4R_D - 24 \quad (\because M_C = -4.48)$

$\therefore R_D = \frac{24 - 4.48}{4} = 4.88 \text{ kN. Ans.}$

Now taking moments about C for ABC, we get

$$M_C = R_A \times (6 + 5) - 9(5 + 4) + R_B \times 5 - 8 \times 3$$

or  $-4.48 = 4.86 \times 11 - 9 \times 9 + R_B \times 5 - 24 \quad (\because M_C = -4.48, R_A = 4.86)$

$\therefore 5R_B = 81 + 24 - 4.86 \times 11 - 4.48 = 47.06$

$\therefore R_B = \frac{47.06}{5} = 9.41 \text{ kN. Ans.}$

Now  $R_C = \text{Total load on ABCD} - (R_A + R_B + R_D)$   
 $= (9 + 8 + 4 \times 3) - (4.86 + 9.41 + 4.88)$   
 $= 9.85 \text{ kN. Ans.}$

Now complete the S.F. diagram as shown in Fig. 15.20 (e).

**15.9.3. Clapeyron's Equation of Three Moments Applied to Continuous Beam with Fixed end Supports.** We have seen in Art. 15.9.2 that fixing moments on the ends of a simply supported continuous beam are zero. But in case of a continuous beam fixed at its one or both ends, there will be fixing moments at the ends, which are fixed. To analyse the continuous beam which is fixed at the ends by the equation of three moments an imaginary support of zero span is introduced. The fixing moment at this imaginary support is always equal to zero.

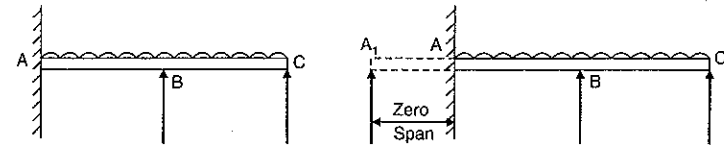

(a) Continuous beam fixed at A

(b) Continuous beam with zero span

Fig. 15.21

If the beam is fixed at the left end A, then an imaginary zero span is introduced to the left of A as shown in Fig. 15.21 (b). But if the beam is fixed at the right end, then an imaginary zero span is introduced to the right end support. After this Clapeyron's equation of three moments is applied.

**Problem 15.12.** A continuous beam ABC of uniform section, with span AB and BC as 4 m each, is fixed at A and simply supported at B and C. The beam is carrying a uniformly distributed load of 6 kN/m run throughout its length. Find the support moments and the reactions. Also draw the bending moment and S.F. diagrams.

**Sol.** Given :

Length AB,  $L_1 = 4 \text{ m}$

Length BC,  $L_2 = 4 \text{ m}$

U.d.l.,  $w = 6 \text{ kN/m.}$

(i) B.M. diagram due to u.d.l. taking each span as simply supported

Consider beam AB as simply supported. The B.M. at the centre of the span AB

$$= \frac{w \cdot L_1^2}{8} = \frac{6 \times 4^2}{8} = 12 \text{ kNm}$$

Similarly B.M. at the centre of span *BC*, considering beam *BC* as simply supported

$$= \frac{w \cdot L^2}{8} = \frac{6 \times 4^2}{8} = 12 \text{ kNm}$$

The B.M. diagram due to u.d.l. taking each span as simply supported is drawn in Fig. 15.22 (c).

(ii) *B.M. diagram due to support moments*

As beam is fixed at *A*, therefore introduce an imaginary zero span *AA*<sub>1</sub> to the left of *A* as shown in Fig. 15.22 (b). The support moment at *A*<sub>1</sub> is zero.

Let  $M_0$  = Support moment at *A*<sub>1</sub> and is zero

$M_A$  = Support moment at *A*

$M_B$  = Support moment at *B*

$M_C$  = Support moment at *C*.

The extreme end *C* is simply supported hence  $M_C = 0$ . To find  $M_A$  and  $M_B$  theorem of three moments is used.

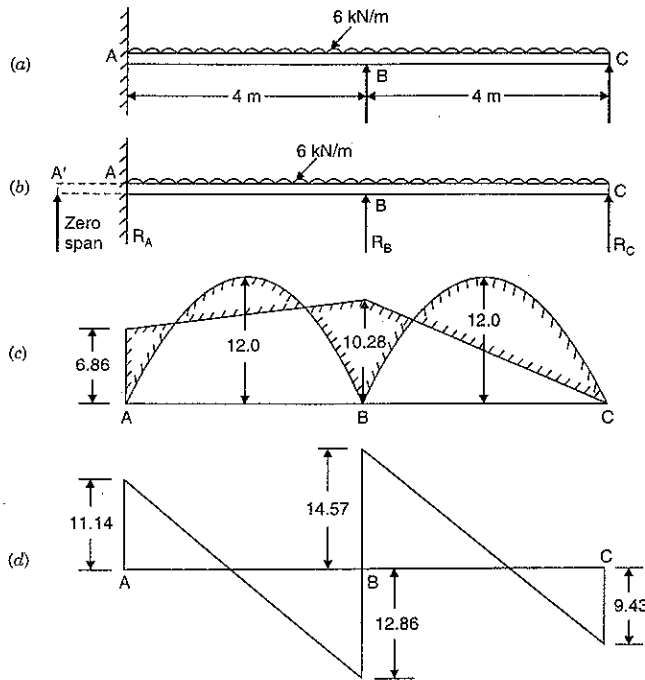

Fig. 15.22

Applying the theorem of three moments for the spans *A*<sub>1</sub>*A* and *AB*, we have

$$M_0 \times 0 + 2M_A(0 + L_1) + M_B L_1 = \frac{6a_0 \bar{x}_0}{L_0} + \frac{6a_1 \bar{x}_1}{L_1}$$

$$\text{or } 0 + 2M_A(0 + 4) + M_B \times 4 = 0 + \frac{6a_1 \bar{x}_1}{4}$$

$$\text{or } 8M_A + 4M_B = \frac{3}{2} a_1 \bar{x}_1 \quad \dots(i)$$

where  $a_1 \bar{x}_1$  = Moment of area of B.M. diagram due to u.d.l. on *AB* when *AB* is considered as simply supported beam about point *B*

$$= \left( \frac{2}{3} \times \text{Base} \times \text{Altitude} \right) \times \frac{L_1}{2}$$

$$= \frac{2}{3} \times 4 \times 12 \times \frac{4}{2} = 64.$$

Substituting this value in equation (i), we get

$$8M_A + 4M_B = \frac{3}{2} \times 64 = 96$$

$$\text{or } 2M_A + M_B = 24 \quad \dots(ii)$$

Now applying the theorem of three moments for the spans *AB* and *BC*, we get

$$M_A \cdot L_1 + 2M_B(L_1 + L_2) + M_C \cdot L_2 = \frac{6a_1 \bar{x}_1}{L_1} + \frac{6a_2 \bar{x}_2}{L_2}$$

$$\text{or } M_A \times 4 + 2M_B(4 + 4) + 0 = \frac{6a_1 \bar{x}_1}{4} + \frac{6a_2 \bar{x}_2}{4} \quad (\because M_C = 0)$$

$$\text{or } 4M_A + 16M_B = \frac{3}{2} a_1 \bar{x}_1 + \frac{3}{2} a_2 \bar{x}_2 \quad \dots(iii)$$

where  $a_1 \bar{x}_1$  = Moment of area of B.M. diagram due to u.d.l. on *AB* when *AB* is considered as simply supported beam about *C*

$$= \frac{2}{3} \times 4 \times 12 \times \frac{4}{2} = 64$$

$a_2 \bar{x}_2$  = Moment of area of B.M. diagram due to u.d.l. on *BC* when *BC* is considered as simply supported beam about *C*

$$= \frac{2}{3} \times 4 \times 12 \times \frac{4}{2} = 64.$$

Substituting these values in equation (iii), we get

$$4M_A + 16M_B = \frac{3}{2} \times 64 + \frac{3}{2} \times 64 = 192$$

$$\text{or } M_A + 4M_B = 48$$

Multiplying the above equation by 2, we get

$$2M_A + 8M_B = 96 \quad \dots(iv)$$

Subtracting equation (ii) from equation (iv), we get

$$7M_B = 96 - 24 = 72$$

$$\text{or } M_B = \frac{72}{7} = 10.28 \text{ kNm. Ans.}$$

Substituting this value in equation (ii), we get

$$2M_A + 10.28 = 24$$

$$\text{or } M_A = \frac{24 \times 10.28}{2} = 6.86 \text{ kNm. Ans.}$$

Now B.M. diagram due to support moments is drawn as shown in Fig. 10.22 (c) in which  $M_B = 6.86$ ,  $M_B = 10.28$ , and  $M_C = 0$ . The B.M. due to supports moments will be negative. Resultant B.M. diagram is also shown in Fig. 15.22 (c).

(iii) *Support Reactions*

Let  $R_A$ ,  $R_B$  and  $R_C$  are the support reactions at A, B and C respectively.

For the span BC, taking moments about B, we get

$$M_B = R_C \times 4 - 6 \times 4 \times \frac{4}{2}$$

$$-10.28 = 4R_C - 48 \quad (\because M_B \text{ is negative})$$

or

or

$$R_C = \frac{48 - 10.28}{4} = 9.43 \text{ kN. Ans.}$$

For the span AB, taking moments about B, we get

$$M_B = M_A + R_A \times 4 - 6 \times 4 \times \frac{4}{2}$$

$$-10.28 = -6.86 + 4R_A - 48 \quad (\because M_B \text{ and } M_A \text{ are negative})$$

or

or

$$R_A = \frac{48 + 6.86 - 10.28}{4} = 11.14 \text{ kN. Ans.}$$

and

$$R_B = \text{Total load} - (R_A + R_C)$$

$$= 6 \times 8 - (11.14 + 9.43) = 27.43 \text{ kN. Ans.}$$

Now complete the S.F. diagram as shown in Fig. 15.22 (d).

**Problem 15.13.** A continuous beam ABC of uniform section, with span AB and BC as 6 m each, is fixed at A and C and supported at B as shown in Fig. 15.23 (a). Find the support moments and the reactions. Draw the S.F. and B.M. diagrams of the beam.

**Sol.** Given :

Length AB,  $L_1 = 6 \text{ m}$   
 Length BC,  $L_2 = 6 \text{ m}$   
 U.d.l. in AB,  $w = 2 \text{ kN/m}$   
 Point load in BC,  $W = 12 \text{ kN}$ .

(i) *B.M. diagram due to vertical loads taking each span as simply supported*

Consider beam AB as simply supported. The B.M. at the centre of AB

$$= \frac{w L_1^2}{8} = \frac{2 \times 6^2}{8} = 9 \text{ kNm.}$$

Consider beam BC as simply supported. The B.M. at the centre of BC

$$= \frac{W \times L_2}{4} = \frac{12 \times 6}{4} = 18 \text{ kNm}$$

The B.M. diagram due to vertical loads is drawn as shown in Fig. 15.23 (c).

(ii) *B.M. diagram due to support moments*

As beam is fixed at A and C, therefore introduce an imaginary zero span  $AA_1$  and  $CC_1$  to the left of A and to the right of C respectively as shown in Fig. 15.23 (b). The support moments at  $A_1$  and  $C_1$  are zero.

Let  $M_0$  = Support moment at  $A_1$  and  $C_1$  and it is zero

$M_A$  = Fixing moment at A

$M_B$  = Support moment at B

$M_C$  = Fixing moment at C.

To find  $M_A$ ,  $M_B$  and  $M_C$ , theorem of three moments is used.

(a) Applying the theorem of three moments for the spans  $A_1A$  and AB, we get

$$M_0 \times 0 + 2M_A(0 + L_1) + M_B \cdot L_1 = \frac{6a_0\bar{x}_0}{L_0} + \frac{6a_1\bar{x}_1}{L_1}$$

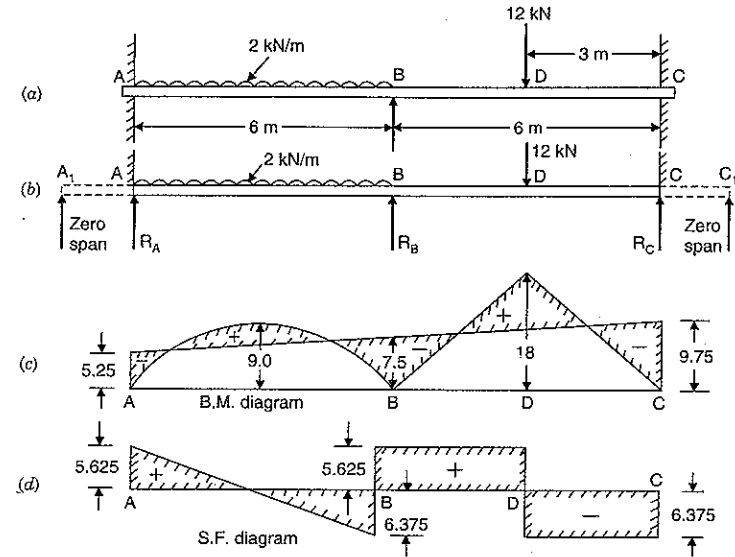

Fig. 15.23

or

$$0 + 2M_A(0 + 6) + M_B \times 6 = 0 + \frac{6a_1\bar{x}_1}{6}$$

or

$$12M_A + 6M_B = a_1\bar{x}_1 \quad \dots(i)$$

where

$a_1\bar{x}_1$  = Moment of area of B.M. diagram due to u.d.l. on AB when it is considered as simply supported beam about B.

$$= \frac{2}{3} \times \text{Base} \times \text{Altitude} \times \frac{L_1}{2}$$

$$= \frac{2}{3} \times 6 \times 9 \times \frac{6}{2} = 108.$$

Substituting this value in equation (i), we get

$$12M_A + 6M_B = 108$$

$$2M_A + M_B = 18 \quad \dots(ii)$$

or

(b) Applying the theorem of three moments for the span AB and BC, we get

$$M_A \cdot L_1 + 2M_B(L_1 + L_2) + M_C \cdot L_2 = \frac{6a_1\bar{x}_1}{L_1} + \frac{6a_2\bar{x}_2}{L_2}$$

$$\text{or } M_A \times 6 + 2M_B(6 + 6) + M_C \times 6 = \frac{6a_1\bar{x}_1}{L_1} + \frac{6a_2\bar{x}_2}{6}$$

$$\text{or } 6M_A + 24M_B + 6M_C = a_1\bar{x}_1 + a_2\bar{x}_2 \quad \dots(iii)$$

$$\text{where } a_1\bar{x}_1 = \frac{2}{3} \times 6 \times 9 \times \frac{6}{2} = 108$$

$$a_2\bar{x}_2 = \text{Moment of area of B.M. diagram due to point load on } BC \text{ when it is considered as simply supported beam about } C$$

$$= \frac{1}{2} \times 6 \times 18 \times 3 = 162$$

Substituting these values in equation (iii), we get

$$6M_A + 24M_B + 6M_C = 108 + 162 = 270$$

$$\text{or } M_A + 4M_B + M_C = 45 \quad \dots(iv)$$

(c) Now applying the theorem of three moments for the span  $BC$  and  $CC_1$ , we get

$$M_B \cdot L_2 + 2M_C(L_2 + 0) + M_0 \times 0 = \frac{6a_2\bar{x}_2}{L_2} + \frac{6a_0\bar{x}_0}{L_0}$$

$$\text{or } M_B \times 6 + 2M_C(6 + 0) + 0 = \frac{6a_2\bar{x}_2}{6} + 0$$

$$\text{or } 6M_B + 12M_C = a_2\bar{x}_2 \quad \dots(v)$$

where  $a_2\bar{x}_2 = \text{Moment of area of B.M. diagram due to point load on } BC \text{ when it is considered as simply supported beam about } B$

$$= \frac{1}{2} \times 6 \times 18 \times 3 = 162.$$

Substituting this value in equation (v), we get

$$6M_B + 12M_C = 162 \quad \dots(vi)$$

$$\text{or } M_B + 2M_C = 27$$

Solving equations (ii), (iv) and (vi), we get

$$M_A = 5.25 \text{ kNm}, \quad M_B = 7.5 \text{ kNm}$$

$$\text{and } M_C = 9.75 \text{ kNm}.$$

Now B.M. diagram due to support moments is drawn as shown in Fig. 15.23 (c). The B.M. due to support moments is negative.

(iii) Support reactions

Let  $R_A$ ,  $R_B$  and  $R_C$  are the support reactions at  $A$ ,  $B$  and  $C$  respectively.

For the span  $AB$ , taking moments about  $B$ , we get

$$M_B = R_A \times 6 - 6 \times 2 \times 3 + M_A$$

$$\text{or } -7.5 = R_A \times 6 - 36 - 5.25 \quad (\because M_B \text{ and } M_A \text{ are negative})$$

$$\text{or } R_A = \frac{36 + 5.25 - 7.5}{6} = 5.625 \text{ kN. Ans.}$$

For the span  $BC$ , taking moments about  $B$ , we get

$$M_B = R_C \times 6 - 12 \times 3 + M_C$$

$$\text{or } -7.5 = R_C \times 6 - 36 - 9.75 \quad (\because M_B \text{ and } M_C \text{ are negative})$$

$$\text{or } R_C = \frac{36 + 9.75 - 7.5}{6} = 6.375 \text{ kN. Ans.}$$

$$\text{Now } R_B = \text{Total load} - (R_A + R_C)$$

$$= (6 \times 2 + 12) - (5.625 + 6.375) = 12 \text{ kN. Ans.}$$

The S.F. is shown in Fig. 15.23 (d).

### HIGHLIGHTS

1. A beam whose both ends are fixed is known as fixed beam. And a beam which is supported on more than two supports is known as a continuous beam.

2. In case of a fixed beam :

$$(i) \alpha = \alpha' \quad (ii) \alpha\bar{x} = \alpha'\bar{x}' \quad \text{and} \quad \bar{x} = \bar{x}'$$

Or

(i) The area of B.M. diagram due to vertical loads is equal to the area of B.M. diagram due to end moments.

(ii) Distance of C.G. of B.M. diagram due to vertical loads is equal to the distance of C.G. of B.M. diagram due to end moments from the same point.

3. The deflection at the centre of a fixed beam carrying a point load at the centre is given by

$$y_c = \frac{WL^3}{192EI}$$

where  $W = \text{Point load,}$

$L = \text{Length of beam.}$

4. The deflection at the centre of a fixed beam carrying a point load at the centre is one-fourth of the deflection of a simply supported beam.

5. The deflection of a fixed beam with an eccentric load, under the point load is given by,

$$y_c = \frac{Wa^3b^3}{3EIL^3}$$

6. (a) For a fixed beam carrying uniformly distributed load over the whole length :

$$\text{End moments} = \frac{W \times L^2}{12}$$

$$\text{Max. deflection} = \frac{w \cdot L^4}{384EI}$$

(b) The deflection at the centre of a fixed beam carrying uniformly distributed load over the whole span is one-fifth of the deflection of a simply supported beam.

7. The end moments of a fixed beam due to sinking of a support is given by

$$M_A = M_B \frac{6EI\delta}{L^2}$$

where  $\delta = \text{Sinking of one support with respect to the other. At the higher end this moment is -ve whereas at the lower end it is positive.}$

8. Clapeyron's theorem of three moments for a continuous beam  $ABC$  is given by,

$$M_A L_1 + 2M_B(L_1 + L_2) + M_C \times L_2 = \frac{6a_1\bar{x}_1}{L_1} + \frac{6a_2\bar{x}_2}{L_2}$$

where  $a_1 = \text{Area of B.M. diagram due to vertical loads on span } AB$

$a_2 = \text{Area of B.M. diagram due to vertical loads on span } BC$

$\bar{x}_1 = \text{Distance of C.G. of B.M. diagram due to vertical loads on } AB \text{ from } A$

$\bar{x}_2 = \text{Distance of C.G. of B.M. diagram due to vertical loads on } BC \text{ from point } C.$

9. To apply the theorem of three moments to a fixed continuous beam, an imaginary support of zero span is introduced.

### EXERCISE 15

#### (A) Theoretical Questions

- What do you mean by a fixed beam and a continuous beam ?
- Prove that for a fixed beam :
  - Area of B.M. diagram due to vertical loads is equal to the area of B.M. diagram due to end moments.
  - Distance of C.G. of B.M. diagram due to vertical loads is equal to the distance of C.G. of B.M. diagram due to end moment from the same point.
- Find an expression for the deflection for a fixed beam carrying a point load at the centre. Also obtain the value of maximum deflection.
- Prove that the deflection at the centre of a fixed beam is one-fourth the deflection of a simply supported beam of the same length, when they carry a point load  $W$  at the centre.
- Draw the S.F. and B.M. diagrams for a fixed beam, carrying an eccentric load.
- Prove that the deflection at the centre of a fixed beam, carrying a uniformly distributed load is given by

$$y_c = \frac{wL^4}{384EI}$$

Determine the position of points of contraflexures also.

- Derive an expression for the fixing moments, when one of the supports of a fixed beam sinks down by  $\delta$  from its original position.
- What are advantages and disadvantages of a fixed beam over a simply supported beam ?
- What is the Clapeyron's theorem of three moments ? Derive an expression for Clapeyron's theorem of three moments.
- How will you apply Clapeyron's theorem of three moments to a
  - continuous beam with simply supported ends
  - continuous beam with fixed end supports ?

#### (B) Numerical Problems

- A fixed beam  $AB$ , 5 m long, carries a point load of 48 kN at its centre. The moment of inertia of the beam is  $5 \times 10^7 \text{ mm}^4$  and value of  $E$  for the beam material is  $2 \times 10^5 \text{ N/mm}^2$ . Determine :
  - Fixed end moments at  $A$  and  $B$ , and
  - Deflection under the load. [Ans. (i)  $M_A = M_B = 30 \text{ kNm}$ , (ii)  $3.125 \text{ mm}$ ]
- A fixed beam of length 5 m carries a point load of 20 kN at a distance of 2 m from  $A$ . Determine the fixed end moments and deflection under the load, if the flexural rigidity of the beam is  $1 \times 10^4 \text{ kNm}^2$ . [Ans.  $M_A = 14.4 \text{ kNm}$ ,  $M_B = 9.6 \text{ kNm}$ ,  $y_C = 1.15 \text{ mm}$ ]
- A fixed beam of length 6 m carries point loads of 20 kN and 15 kN at distances 2 m and 4 m from the left end  $A$ . Find the fixed end moments and the reactions at the supports. Draw B.M. and S.F. diagrams. [Ans.  $M_A = 24.44 \text{ kNm}$ ,  $M_B = 22.22 \text{ kNm}$ ,  $R_A = 18.70 \text{ kN}$ ,  $R_B = 16.30 \text{ kN}$ ]
- A fixed beam of length 3 m carries two point loads of 30 kN each at a distance of 1 m from both the ends. Determine the fixing moments and draw the B.M. diagram. [Ans.  $M_A = M_B = 20 \text{ kNm}$ ]

- A fixed beam  $AB$  of length 6 m carries a uniformly distributed load of 3 kN/m over the left half of the span together with a point load of 4 kN at a distance of 4.5 m from the left end. Determine the fixing end moments and the support reactions. [Ans.  $M_A = 7.3 \text{ kNm}$ ,  $M_B = 6.2 \text{ kNm}$ ,  $R_A = 7.93 \text{ kN}$ ,  $R_B = 5.07 \text{ kN}$ ]
- A fixed beam  $AB$  of length 6 m is having moment of inertia  $I = 5 \times 10^6 \text{ mm}^4$ . The support  $B$  sinks down by 6 mm. If  $E = 2 \times 10^5 \text{ N/mm}^2$  find the fixing moments. [Ans.  $M_A = M_B = 1000 \text{ Nm}$ ]
- A continuous beam  $ABC$  of length 10 m rests on three supports  $A$ ,  $B$  and  $C$  at the same level in which span  $AB = 6 \text{ m}$  and span  $BC = 4 \text{ m}$ . In span  $AB$ , there is a point load of 3 kN at a distance of 2 m from the end  $A$ , whereas in the span  $BC$ , there is a uniformly distributed load of 1 kN/m run over the whole length. Determine the support moments and support reactions. Draw S.F. and B.M. diagrams also. [Ans. (i)  $M_A = M_C = 0$ ,  $M_B = 2.4 \text{ kNm}$ , (ii)  $R_A = 1.6 \text{ kN}$ ,  $R_B = 4 \text{ kN}$ ,  $R_C = 1.4 \text{ kN}$ ]
- A continuous beam consists of three successive spans of 8 m, 10 m and 6 m and carries loads of 6 kN/m, 4 kN/m and 8 kN/m respectively on the spans. Determine the bending moments and reactions at the supports. [Ans. (i)  $M_A = M_D = 0$ ,  $M_C = 32.2 \text{ kNm}$ ,  $M_B = 40.16 \text{ kNm}$ , (ii)  $R_A = 18.98 \text{ kN}$ ,  $R_B = 49.82 \text{ kN}$ ,  $R_C = 48.57 \text{ kN}$ ,  $R_D = 18.63 \text{ kN}$ ]
- A continuous beam  $ABC$  consists of two consecutive spans  $AB$  and  $BC$  of length 8 m and 6 m respectively. The beam carries a uniformly distributed load of 1 kN/m throughout its length. The end  $A$  is fixed and the end  $C$  is simply supported. Find the support moments and the reactions. Also draw the S.F. and B.M. diagrams. [Ans. (i)  $M_A = 5.75 \text{ kNm}$ ,  $M_B = 4.5 \text{ kNm}$ ,  $M_C = 0$ , (ii)  $R_A = 4.15 \text{ kN}$ ,  $R_B = 7.6 \text{ kN}$ ,  $R_C = 2.25 \text{ kN}$ ]
- Draw the S.F. and B.M. diagram of a continuous beam  $ABC$  of length 10 m which is fixed at  $A$  and is supported on  $B$  and  $C$ . The beam carries a uniformly distributed load of 2 kN/m length over the entire length. The spans  $AB$  and  $BC$  are equal to 5 m each. [Ans. (i)  $M_A = 3.57 \text{ kNm}$ ,  $M_B = 5.357 \text{ kNm}$ ,  $M_C = 0$ , (ii)  $R_A = 5.357 \text{ kN}$ ,  $R_B = 8.571 \text{ kN}$ ,  $R_C = 6.071 \text{ kN}$ ]

# 16

## Torsion of Shafts and Springs

### 16.1. INTRODUCTION

A shaft is said to be in torsion, when equal and opposite torques are applied at the two ends of the shaft. The torque is equal to the product of the force applied (tangentially to the ends of a shaft) and radius of the shaft. Due to the application of the torques at the two ends, the shaft is subjected to a twisting moment. This causes the shear stresses and shear strains in the material of the shaft.

### 16.2. DERIVATION OF SHEAR STRESS PRODUCED IN A CIRCULAR SHAFT SUBJECTED TO TORSION

When a circular shaft is subjected to torsion, shear stresses are set up in the material of the shaft. To determine the magnitude of shear stress at any point on the shaft, consider a shaft fixed at one end *AA* and free at the end *BB* as shown in Fig. 16.1. Let *CD* is any line on the outer surface of the shaft. Now let the shaft is subjected to a torque *T* at the end *BB* as shown in Fig. 16.2. As a result of this torque *T*, the shaft at the end *BB* will rotate clockwise and every cross-section of the shaft will be subjected to shear stresses. The point *D* will shift to *D'* and hence line *CD* will be deflected to *CD'* as shown in Fig. 16.2 (a). The line *OD* will be shifted to *OD'* as shown in Fig. 16.2 (b).

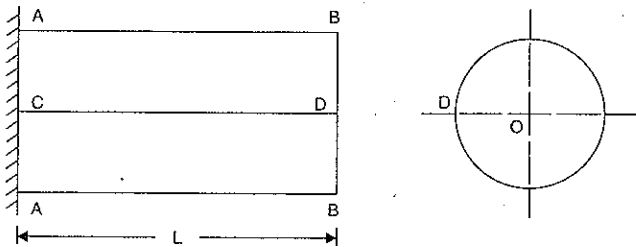

Fig. 16.1. Shaft fixed at one end *AA* before torque *T* is applied.

- Let *R* = Radius of shaft
- L* = Length of shaft
- T* = Torque applied at the end *BB*
- $\tau$  = Shear stress induced at the surface of the shaft due to torque *T*
- C* = Modulus of rigidity of the material of the shaft

$\phi = \angle DCD'$  also equal to shear strain  
 $\theta = \angle DOD'$  and is also called angle of twist.

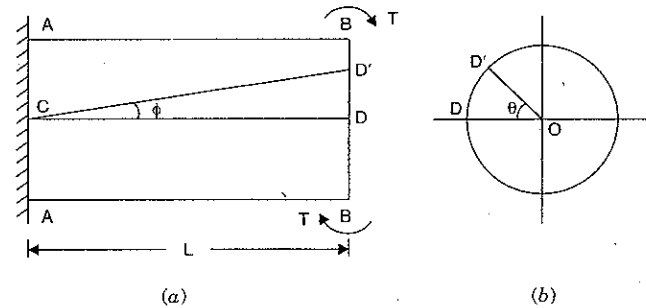

Fig. 16.2. Shaft fixed at *AA* and subjected to torque *T* at *BB*.

Now distortion at the outer surface due to torque *T*

$$= DD'$$

$\therefore$  Shear strain at outer surface

= Distortion per unit length

$$= \frac{\text{Distortion at the outer surface}}{\text{Length of shaft}} = \frac{DD'}{L}$$

$$= \frac{DD'}{CD} = \tan \phi$$

(if  $\phi$  is very small then  $\tan \phi \approx \phi$ )

$\therefore$  Shear strain at outer surface,

$$\phi = \frac{DD'}{L} \quad \dots(i)$$

Now from Fig. 16.2 (b).

$$\text{Arc } DD' = OD \times \theta = R\theta \quad (\because OD = R = \text{Radius of shaft})$$

Substituting the value of *DD'* in equation (i), we get

Shear strain at outer surface

$$\phi = \frac{R \times \theta}{L} \quad \dots(ii)$$

Now the modulus of rigidity (*C*) of the material of the shaft is given as

$$C = \frac{\text{Shear stress induced}}{\text{Shear strain produced}} = \frac{\text{Shear stress at the outer surface}}{\text{Shear strain at outer surface}}$$

$$= \frac{\tau}{\left(\frac{R\theta}{L}\right)} \quad \left(\because \text{From equation (ii), shear strain} = \frac{R\theta}{L}\right)$$

$$= \frac{\tau \times L}{R\theta}$$

$$\therefore \frac{C\theta}{L} = \frac{\tau}{R} \quad \dots(16.1)$$



$$\tau = \frac{R \times C \times \theta}{L}$$

Now for a given shaft subjected to a given torque ( $T$ ), the values of  $C$ ,  $\theta$  and  $L$  are constant. Hence shear stress produced is proportional to the radius  $R$ .

$$\therefore \tau \propto R \quad \text{or} \quad \frac{\tau}{R} = \text{constant} \quad \dots(iii)$$

If  $q$  is the shear stress induced at a radius ' $r$ ' from the centre of the shaft then

$$\frac{\tau}{R} = \frac{q}{r} \quad \dots(16.2)$$

But  $\frac{\tau}{R} = \frac{C\theta}{L}$  from equation (16.1)

$$\therefore \frac{\tau}{R} = \frac{C\theta}{L} = \frac{q}{r} \quad \dots(16.3)$$

From equation (iii), it is clear that shear stress at any point in the shaft is proportional to the distance of the point from the axis of the shaft. Hence the shear stress is maximum at the outer surface and shear stress is zero at the axis of the shaft.

**16.2.1. Assumptions Made in the Derivation of Shear Stress Produced in a Circular Shaft Subjected to Torsion.** The derivation of shear stress produced in a circular shaft subjected to torsion, is based on the following assumptions :

1. The material of the shaft is uniform throughout.
2. The twist along the shaft is uniform.
3. The shaft is of uniform circular section throughout.
4. Cross-sections of the shaft, which are plane before twist remain plane after twist.
5. All radii which are straight before twist remain straight after twist.

### 16.3. MAXIMUM TORQUE TRANSMITTED BY A CIRCULAR SOLID SHAFT

The maximum torque transmitted by a circular solid shaft, is obtained from the maximum shear stress induced at the outer surface of the solid shaft. Consider a shaft subjected to a torque  $T$  as shown in Fig. 16.3.

- Let  $\tau$  = Maximum shear stress induced at the outer surface  
 $R$  = Radius of the shaft  
 $q$  = Shear stress at a radius ' $r$ ' from the centre.

Consider an elementary circular ring of thickness ' $dr$ ' at a distance ' $r$ ' from the centre as shown in Fig. 16.3. Then the area of the ring,

$$dA = 2\pi r dr$$

From equation (16.2), we have

$$\frac{\tau}{R} = \frac{q}{r}$$

$\therefore$  Shear stress at the radius  $r$ ,

$$q = \frac{\tau}{R} r = \tau \frac{r}{R}$$

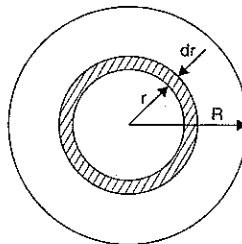

Fig. 16.3

$\therefore$  Turning force on the elementary circular ring

$$= \text{Shear stress acting on the ring} \times \text{Area of ring} \\ = q \times dA$$

$$= \tau \times \frac{r}{R} \times 2\pi r dr \quad \left( \because q = \tau \times \frac{r}{R} \right) \\ = \frac{\tau}{R} \times 2\pi r^2 dr$$

Now turning moment due to the turning force on the elementary ring,

$$dT = \text{Turning force on the ring} \times \text{Distance of the ring from the axis}$$

$$= \frac{\tau}{R} \times 2\pi r^2 dr \times r$$

$$= \frac{\tau}{R} \times 2\pi r^3 dr \quad \dots[16.3 (A)]$$

$\therefore$  The total turning moment (or total torque) is obtained by integrating the above equation between the limits  $O$  and  $R$

$$T = \int_0^R dT = \int_0^R \frac{\tau}{R} \times 2\pi r^3 dr$$

$$= \frac{\tau}{R} \times 2\pi \int_0^R r^3 dr = \frac{\tau}{R} \times 2\pi \left[ \frac{r^4}{4} \right]_0^R$$

$$= \frac{\tau}{R} \times 2\pi \times \frac{R^4}{4} = \tau \times \frac{\pi}{2} \times R^3$$

$$= \tau \times \frac{\pi}{2} \times \left( \frac{D}{2} \right)^3 \quad \left( \because R = \frac{D}{2} \right)$$

$$= \tau \times \frac{\pi}{2} \times \frac{D^3}{8} = \tau \times \frac{\pi D^3}{16} = \frac{\pi}{16} \tau D^3 \quad \dots(16.4)$$

**Problem 16.1.** A solid shaft of 150 mm diameter is used to transmit torque. Find the maximum torque transmitted by the shaft if the maximum shear stress induced to the shaft is 45 N/mm<sup>2</sup>.

**Sol.** Given :

Diameter of the shaft,  $D = 150$  mm

Maximum shear stress,  $\tau = 45$  N/mm<sup>2</sup>

Let  $T$  = Maximum torque transmitted by the shaft.

$$\text{Using equation (16.4), } T = \frac{\pi}{16} \tau D^3 = \frac{\pi}{16} \times 45 \times 150^3$$

$$= 29820586 \text{ N-mm} = \mathbf{29820.586 \text{ N-m. Ans.}}$$

**Problem 16.2.** The shearing stress in a solid shaft is not to exceed 40 N/mm<sup>2</sup> when the torque transmitted is 20000 N-m. Determine the minimum diameter of the shaft.

**Sol.** Given :

Maximum shear stress,  $\tau = 40$  N/mm<sup>2</sup>

Torque transmitted,  $T = 20000$  N-m =  $20000 \times 10^3$  N-mm

Let  $D$  = Minimum diameter of the shaft in mm.

Using equation (16.4),

$$T = \frac{\pi}{16} \tau D^3$$

or

$$D = \left( \frac{16T}{\pi\tau} \right)^{1/3} = \left( \frac{16 \times 20000 \times 10^3}{\pi \times 40} \right)^{1/3} = 136.2 \text{ mm. Ans.}$$

#### 16.4. TORQUE TRANSMITTED BY A HOLLOW CIRCULAR SHAFTS

Torque transmitted by a hollow circular shaft is obtained in the same way as for a solid shaft. Consider a hollow shaft. Let it is subjected to a torque  $T$  as shown in Fig. 16.4. Take an elementary circular ring of thickness ' $dr$ ' at a distance  $r$  from the centre as shown in Fig. 16.4.

Let  $R_0$  = Outer radius of the shaft

$R_i$  = Inner radius of the shaft

$r$  = Radius of elementary circular ring

$dr$  = Thickness of the ring

$\tau$  = Maximum shear stress induced at outer surface of the shaft

$q$  = Shear stress induced on the elementary ring

$dA$  = Area of the elementary circular ring

$$= 2\pi r \times dr$$

Shear stress at the elementary ring is obtained from equation (16.2) as

$$\frac{\tau}{R_0} = \frac{q}{r} \quad (\because \text{Here outer radius } R = R_0)$$

$$\therefore q = \frac{\tau}{R_0} \times r$$

$\therefore$  Turning force on the ring = Stress  $\times$  Area =  $q \times dA$

$$= \frac{\tau}{R_0} r \times 2\pi r dr \quad \left( \because q = \frac{\tau}{R_0} r \right)$$

$$= 2\pi \frac{\tau}{R_0} r^2 dr$$

Turning moment ( $dT$ ) on the ring,

$dT$  = Turning force  $\times$  Distance of the ring from centre

$$= 2\pi \frac{\tau}{R_0} r^2 dr \times r = 2\pi \frac{\tau}{R_0} r^3 dr$$

The total turning moment (or total torque  $T$ ) is obtained by integrating the above equation between the limits  $R_i$  and  $R_0$ .

$$T = \int_{R_i}^{R_0} dT = \int_{R_i}^{R_0} 2\pi \frac{\tau}{R_0} r^3 dr$$

$$= 2\pi \frac{\tau}{R_0} \int_{R_i}^{R_0} r^3 dr$$

( $\because \tau$  and  $R_0$  are constant and can be taken outside the integral)

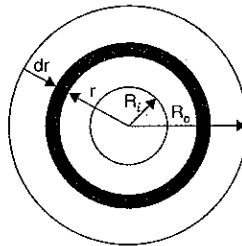

Fig. 16.4. Hollow shaft.

$$\begin{aligned} &= 2\pi \frac{\tau}{R_0} \left[ \frac{r^4}{4} \right]_{R_i}^{R_0} = 2\pi \frac{\tau}{R_0} \left[ \frac{R_0^4 - R_i^4}{4} \right] \\ &= \frac{\pi}{2} \tau \left[ \frac{R_0^4 - R_i^4}{R_0} \right] \quad \dots(16.5) \end{aligned}$$

Let  $D_0$  = Outer diameter of the shaft

$D_i$  = Inner diameter of the shaft.

Then  $R_0 = \frac{D_0}{2}$  and  $R_i = \frac{D_i}{2}$ .

Substituting the values of  $R_0$  and  $R_i$  in equation (16.5),

$$\begin{aligned} T &= \frac{\pi}{2} \tau \left[ \frac{\left( \frac{D_0}{2} \right)^4 - \left( \frac{D_i}{2} \right)^4}{\left( \frac{D_0}{2} \right)} \right] = \frac{\pi}{2} \tau \left[ \frac{\frac{D_0^4}{16} - \frac{D_i^4}{16}}{\frac{D_0}{2}} \right] \\ &= \frac{\pi}{2} \tau \left[ \frac{D_0^4 - D_i^4}{16} \times \frac{2}{D_0} \right] \\ &= \frac{\pi}{16} \tau \left[ \frac{D_0^4 - D_i^4}{D_0} \right] \quad \dots(16.6) \end{aligned}$$

#### 16.5. POWER TRANSMITTED BY SHAFTS

Once the expression for torque ( $T$ ) for a solid or a hollow shaft is obtained, power transmitted by the shafts can be determined.

Let  $N$  = r.p.m. of the shaft

$T$  = Mean torque transmitted in N-m

$\omega$  = Angular speed of shaft.

Then Power =  $\frac{2\pi NT^*}{60}$  watts ...(16.7)

$$= \omega \times T \quad \left( \because \frac{2\pi N}{60} = \omega \right)$$

$$= T \times \omega \quad \dots[16.7 (A)]$$

**Problem 16.3.** In a hollow circular shaft of outer and inner diameters of 20 cm and 10 cm respectively, the shear stress is not to exceed 40 N/mm<sup>2</sup>. Find the maximum torque which the shaft can safely transmit.

**Sol.** Given :

Outer diameter,  $D_0 = 20 \text{ cm} = 200 \text{ mm}$

Inner diameter,  $D_i = 10 \text{ cm} = 100 \text{ mm}$

Maximum shear stress,  $\tau = 40 \text{ N/mm}^2$

Let  $T$  = Maximum torque transmitted by the shaft.

\*The torque  $T$  obtained by this formula is the average (or mean) torque.

Using equation (16.6),

$$T = \frac{\pi}{16} \tau \left[ \frac{D_0^4 - D_i^4}{D_0} \right] = \frac{\pi}{16} \times 40 \left[ \frac{200^4 - 100^4}{200} \right]$$

$$= \frac{\pi}{16} \times 40 \left[ \frac{16 \times 10^8 - 1 \times 10^8}{200} \right] = 58904860 \text{ Nmm}$$

$$= 58904.86 \text{ Nm. Ans.}$$

**Problem 16.4.** Two shafts of the same material and of same lengths are subjected to the same torque, if the first shaft is of a solid circular section and the second shaft is of hollow circular section, whose internal diameter is 2/3 of the outside diameter and the maximum shear stress developed in each shaft is the same, compare the weights of the shafts.

(AMIE, Summer 1989)

**Sol. Given :**

Two shafts of the same material and same lengths (one is solid and other is hollow) transmit the same torque and develops the same maximum stress.

Let  $T$  = Torque transmitted by each shaft

$\tau$  = Max. shear stress developed in each shaft

$D$  = Outer diameter of the solid shaft

$D_0$  = Outer diameter of the hollow shaft

$D_i$  = Inner diameter of the hollow shaft =  $\frac{2}{3}D_0$

$W_s$  = Weight of the solid shaft

$W_h$  = Weight of the hollow shaft

$L$  = Length of each shaft

$w$  = Weight density of the material of each shaft.

Torque transmitted by the solid shaft is given by equation (16.4)

$$T = \frac{\pi}{16} \tau D^3 \quad \dots(i)$$

Torque transmitted by the hollow shaft is given by equation (16.6),

$$T = \frac{\pi}{16} \tau \left[ \frac{D_0^4 - D_i^4}{D_0} \right] = \frac{\pi}{16} \tau \left[ \frac{D_0^4 - (2/3 D_0)^4}{D_0} \right]$$

$$= \frac{\pi}{16} \tau \left[ \frac{D_0^4 - \frac{16}{81} D_0^4}{D_0} \right] = \frac{\pi}{16} \tau \times \frac{65 D_0^4}{81 \times D_0}$$

$$= \frac{\pi}{16} \tau \times \frac{65 D_0^3}{81} \quad \dots(ii)$$

As torque transmitted by solid and hollow shafts are equal, hence equating equations (i) and (ii),

$$\frac{\pi}{16} \tau D^3 = \frac{\pi}{16} \tau \times \frac{65}{81} D_0^3$$

Cancelling  $\frac{\pi}{16} \tau$  to both sides

$$\text{or} \quad D^3 = \frac{65}{81} D_0^3$$

$$\therefore D = \left[ \frac{65}{81} D_0^3 \right]^{1/3} = \left( \frac{65}{81} \right)^{1/3} D_0 = 0.929 D_0 \quad \dots(iii)$$

Now weight of solid shaft,  $W_s$  = Weight density  $\times$  Volume of solid shaft

$$= w \times \text{Area of cross-section} \times \text{Length}$$

$$= w \times \frac{\pi}{4} D^2 \times L \quad \dots(iv)$$

Weight of hollow shaft,

$$W_h = w \times \text{Area of cross-section of hollow shaft} \times \text{Length}$$

$$= w \times \frac{\pi}{4} [D_0^2 - D_i^2] \times L = w \times \frac{\pi}{4} [D_0^2 - (2/3 D_0)^2] \times L$$

$$= w \times \frac{\pi}{4} \left[ D_0^2 - \frac{4}{9} D_0^2 \right] \times L = w \times \frac{\pi}{4} \times \frac{5}{9} D_0^2 \times L \quad \dots(v)$$

Dividing equation (iv) by equation (v),

$$\frac{W_s}{W_h} = \frac{w \times \frac{\pi}{4} D^2 \times L}{w \times \frac{\pi}{4} \times \frac{5}{9} D_0^2 \times L} = \frac{9D^2}{5D_0^2}$$

$$= \frac{9}{5} \times \frac{(0.929 D_0)^2}{D_0^2} \quad [\because D = 0.929 D_0 \text{ from equation (iii)}]$$

$$= \frac{9}{5} \times 0.929^2 \times \frac{D_0^2}{D_0^2} = \frac{1.55}{1}$$

$$\therefore \frac{\text{Weight of solid shaft}}{\text{Weight of hollow shaft}} = \frac{1.55}{1} \quad \text{Ans.}$$

**Problem 16.5.** A solid circular shaft and a hollow circular shaft whose inside diameter is  $\left(\frac{3}{4}\right)$  of the outside diameter, are of the same material, of equal lengths and are required to transmit a given torque. Compare the weights of these two shafts if the maximum shear stress developed in the two shafts are equal. (AMIE, Winter 1988)

**Sol. Given :**

Dia. of hollow shaft,  $D_i = \frac{3}{4}$  Dia. at outside

$$= \frac{3}{4} D_0 = 0.75 D_0$$

Let  $L$  = Length of both shaft (equal length),

$T$  = Torque transmitted by each shaft (equal torque),

$\tau$  = Maximum shear stress developed in each shaft (equal max. shear stress),

$D$  = Dia. of solid shaft,

$W_s$  = Weight of solid shaft, and

$W_h$  = Weight of hollow shaft.

Torque transmitted by a solid shaft is given by equation (16.4) as

$$T = \frac{\pi}{16} \tau \times D^3 \quad \dots(i)$$

Torque transmitted by a hollow shaft is given by equation (16.6) as

$$\begin{aligned} T &= \frac{\pi}{16} \times \tau \times \left[ \frac{D_0^4 - D_i^4}{D_0} \right] = \frac{\pi}{16} \times \tau \times \left[ \frac{D_0^4 - (0.75 D_0)^4}{D_0} \right] \\ &= \frac{\pi}{16} \times \tau \times \frac{D_0^4}{D_0} [1 - (0.75)^4] = \frac{\pi}{16} \times \tau \times D_0^3 \times [1 - 0.3164] \\ &= \frac{\pi}{16} \times \tau \times D_0^3 \times 0.6836 \quad \dots(ii) \end{aligned}$$

But torque transmitted by solid shaft

= Torque transmitted by hollow shaft.

Hence equating equations (i) and (ii), we get

$$\begin{aligned} \frac{\pi}{16} \times \tau \times D^3 &= \frac{\pi}{16} \times \tau \times D_0^3 \times 0.6836 \quad \text{or} \quad D^3 = 0.6836 D_0^3 \\ \therefore D &= (0.6836)^{1/3} \times D_0 \quad \text{or} \quad D = 0.8809 D_0 \quad \dots(iii) \end{aligned}$$

Now weight of solid shaft,

$$\begin{aligned} W_s &= \rho \times g \times \text{Volume of solid shaft} \\ &= \rho \times g \times \left( \frac{\pi}{4} D^2 \times L \right) \quad \dots(iv) \end{aligned}$$

Weight of hollow shaft,

$$\begin{aligned} W_h &= \rho \times g \times \text{Volume of hollow shaft} \\ &= \rho \times g \times \left[ \frac{\pi}{4} (D_0^2 - D_i^2) \times L \right] = \rho \times g \times \frac{\pi}{4} [D_0^2 - (0.75 D_0)^2] \times L \\ &= \rho \times g \times \frac{\pi}{4} [D_0^2 - 0.5625 D_0^2] \times L = \rho \times g \times \frac{\pi}{4} \times D_0^2 (1 - 0.5625) \times L \\ &= \rho \times g \times \frac{\pi}{4} \times D_0^2 \times 0.4375 \times L \quad \dots(v) \end{aligned}$$

Dividing equation (iv) by equation (v),

$$\begin{aligned} \frac{W_s}{W_h} &= \frac{\rho \times g \times \frac{\pi}{4} \times D^2 \times L}{\rho \times g \times \frac{\pi}{4} D_0^2 \times 0.4375 \times L} = \frac{D^2}{0.4375 D_0^2} \\ &= \frac{(0.8809 D_0)^2}{0.4375 D_0^2} \quad [\because \text{From (iii), } D = 0.8809 D_0] \\ &= \frac{0.776 D_0^2}{0.4375 D_0^2} = 1.7737. \quad \text{Ans.} \end{aligned}$$

**Problem 16.6.** A hollow circular shaft 20 mm thick transmits 300 kW power at 200 r.p.m. Determine the external diameter of the shaft if the shear strain due to torsion is not to exceed 0.00086. Take modulus of rigidity =  $0.8 \times 10^5 \text{ N/mm}^2$ .

(AMIE, Summer 1989 Converted to S.I. units)

**Sol. Given :**

Thickness,  $t = 20 \text{ mm}$   
Power transmitted,  $P = 300 \text{ kW} = 300,000 \text{ W}$

Speed,  $N = 200 \text{ r.p.m.}$   
Shear strain,  $\phi = 0.00086$   
Modulus of rigidity,  $C = 0.8 \times 10^5 \text{ N/mm}^2$   
Let  $D_0 =$  External dia. of shaft and  
 $D_i =$  Internal dia. of shaft  
Then  $D_0 = D_i + 2t = D_i + 2 \times 20$   
 $\therefore D_i = D_0 - 40 \quad \dots(i)$

Using equation (16.7),

$$P = \frac{2\pi NT}{60} \quad (\text{or } T \times \omega) \quad \text{or} \quad 300000 = \frac{2\pi \times 200 \times T}{60} \quad (\text{or } T \times \omega)$$

$$\begin{aligned} \therefore T &= \frac{300000 \times 60}{2\pi \times 200} = 14323.9 \text{ Nm} \\ &= 14323.9 \times 1000 \text{ Nmm} = 14323900 \text{ Nmm.} \end{aligned}$$

Also we know,  $C = \frac{\text{Shear stress}}{\text{Shear strain}}$

$$\text{or} \quad 0.8 \times 10^5 = \frac{\text{Shear stress}}{0.00086}$$

$\therefore$  Shear stress ( $\tau$ ) =  $0.8 \times 10^5 \times 0.00086 = 68.8 \text{ N/mm}^2$

Now using equation (16.6),

$$T = \frac{\pi}{16} \times \tau \times \frac{(D_0^4 - D_i^4)}{D_0}$$

$$\text{or} \quad 14323900 = \frac{\pi}{16} \times 68.8 \times \frac{(D_0^4 - D_i^4)}{D_0}$$

$$\text{or} \quad \frac{14323900 \times 16 \times D_0}{\pi \times 68.8} = D_0^4 - D_i^4$$

$$1060334.6 D_0 = D_0^4 - D_i^4 = (D_0^2 + D_i^2)(D_0^2 - D_i^2)$$

Substituting the value of  $D_i$  from equation (i) into the above equation, we get

$$\begin{aligned} 1060334.6 D_0 &= [D_0^2 + (D_0 - 40)^2][D_0^2 - (D_0 - 40)^2] \\ &= [D_0^2 + D_0^2 + 1600 - 80D_0][D_0^2 - D_0^2 - 1600 + 80D_0] \\ &= (2D_0^2 + 1600 - 80D_0)(80D_0 - 1600) \\ &= 2(D_0^2 + 800 - 40D_0)80(D_0 - 20) \\ &= 160(D_0^2 - 40D_0 + 800)(D_0 - 20) \end{aligned}$$

$$\text{or} \quad \frac{1060334.6 D_0}{160} = (D_0^2 - 40D_0 + 800)(D_0 - 20)$$

$$\text{or} \quad 6627 D_0 = D_0^3 - 20D_0^2 - 40D_0^2 + 800D_0 + 800D_0 - 16000$$

$$\text{or} \quad D_0^3 - 60D_0^2 + 1600D_0 - 6627D_0 - 16000 = 0$$

$$\text{or} \quad D_0^3 - 60D_0^2 - 5027D_0 - 16000 = 0 \quad \dots(ii)$$

The equation (ii) is solved by trial and error method.

(i) Let  $D_0 = 100$  mm.

Substituting this value of  $D_0$  in the L.H.S. of equation (ii), we get

$$\begin{aligned} \text{L.H.S.} &= 100^3 - 60 \times 100^2 - 5027 \times 100 - 16000 \\ &= 1000000 - 600000 - 502700 - 16000 = 1000000 - 1118700 = -118700 \end{aligned}$$

(ii) Let  $D_0 = 110$  mm

Substituting this value in the L.H.S. of equation (ii), we get

$$\begin{aligned} \text{L.H.S.} &= 110^3 - 60 \times 110^2 - 5027 \times 110 - 16000 \\ &= 1331000 - 726000 - 552970 - 16000 = 1331000 - 1294970 = 36030 \end{aligned}$$

When  $D_0 = 100$  mm, the L.H.S. of equation (ii), is negative but when  $D_0 = 110$  mm, the L.H.S. is positive. Hence the value of  $D_0$  lies between 100 and 110 mm. The value of  $D_0$  is more nearer to 110 mm as 36030 is less than 118700.

(iii) Let  $D_0 = 108$  mm.

Substituting this value in the L.H.S. of equation (ii), we get

$$\begin{aligned} \text{L.H.S.} &= 108^3 - 6 \times 108^2 - 5027 \times 108 - 16000 \\ &= 1259910 - 699840 - 542916 - 16000 = 1259910 - 1258716 = 1194 \end{aligned}$$

The value of  $D_0$  will be slightly less than 108 mm, which may be taken as 107.5 mm. **Ans.**

**Problem 16.7.** A hollow shaft of external diameter 120 mm transmits 300 kW power at 200 r.p.m. Determine the maximum internal diameter if the maximum stress in the shaft is not to exceed 60 N/mm<sup>2</sup>. (AMIE, Summer 1990)

**Sol.** Given :

External dia.,	$D_0 = 120$ mm
Power,	$P = 300$ kW = 300,000 W
Speed,	$N = 200$ r.p.m.
Max. shear stress,	$\tau = 60$ N/mm <sup>2</sup>
Let	$D_i =$ Internal dia. of shaft

Using equation (16.7),

$$P = \frac{2\pi NT}{60} \quad \text{or} \quad 300,000 = \frac{2\pi \times 200 \times T}{60}$$

$$T = \frac{300,000 \times 60}{2\pi \times 200} = 14323.9 \text{ Nm}$$

$$= 14323.9 \times 1000 \text{ Nmm} = 14323900 \text{ Nmm}$$

Now using equation (16.6),

$$T = \frac{\pi}{16} \times \tau \times \frac{(D_0^4 - D_i^4)}{D_0}$$

$$\text{or} \quad 14323900 = \frac{\pi}{16} \times 60 \times \frac{(120^4 - D_i^4)}{120}$$

$$\text{or} \quad \frac{14323900 \times 16 \times 120}{\pi \times 60} = 120^4 - D_i^4$$

$$145902000 = 207360000 - D_i^4$$

$$D_i^4 = 207360000 - 145902000 = 61458000$$

$$D_i = (61458000)^{1/4} = 88.5 \text{ mm. Ans.}$$

**Problem 16.8.** Find the maximum shear stress induced in a solid circular shaft of diameter 15 cm when the shaft transmits 150 kW power at 180 r.p.m.

**Sol.** Given :

Diameter of shaft,	$D = 15$ cm = 150 mm
Power transmitted,	$P = 150$ kW = $150 \times 10^3$ W
Speed of shaft,	$N = 180$ r.p.m.

Let  $\tau =$  Maximum shear stress induced in the shaft

Power transmitted is given by equation (16.7) as

$$P = \frac{2\pi NT}{60}$$

$$150 \times 10^3 = \frac{2\pi \times 180 \times T}{60}$$

$$\therefore T = \frac{150 \times 10^3 \times 60}{2\pi \times 180} = 7957.7 \text{ Nm} = 7957700 \text{ Nmm}$$

Now using equation (16.4) as,

$$T = \frac{\pi}{16} \tau D^3$$

$$7957700 = \frac{\pi}{16} \times \tau \times 150^3$$

$$\therefore \tau = \frac{16 \times 7957700}{\pi \times 150^3} = 12 \text{ N/mm}^2. \text{ Ans.}$$

**Problem 16.9.** A solid cylindrical shaft is to transmit 300 kW power at 100 r.p.m.

(a) If the shear stress is not to exceed 80 N/mm<sup>2</sup>, find its diameter.

(b) What percent saving in weight would be obtained if this shaft is replaced by a hollow one whose internal diameter equals to 0.6 of the external diameter, the length, the material and maximum shear stress being the same? (AMIE, Winter 1983)

**Sol.** Given :

Power,	$P = 300$ kW = 300,000 W
Speed,	$N = 100$
Max. shear stress,	$\tau = 80$ N/mm <sup>2</sup>

(a) Let  $D =$  Dia. of solid shaft

Using equation (16.7),

$$P = \frac{2\pi NT}{60}$$

$$300 \times 10^3 = \frac{2\pi \times 100 \times T}{60}$$

$$\therefore T = \frac{300 \times 10^3 \times 60}{2\pi \times 100} = 28647.8 \text{ Nm} = 28647800 \text{ Nmm}$$

Now using equation (16.4),

$$T = \frac{\pi}{16} \times \tau \times D^3 \quad \text{or} \quad 28647800 = \frac{\pi}{16} \times 80 \times D^3$$

$$D = \left( \frac{16 \times 28647800}{\pi \times 80} \right)^{1/3} = 121.8 \text{ mm}$$

$$= \text{say } 122.0 \text{ mm. Ans.}$$

(b) *Percent saving in weight*

Let  $D_0$  = External dia. of hollow shaft

$D_i$  = Internal dia. of hollow shaft

$$= 0.6 \times D_0 \quad (\text{given})$$

The length, material and maximum shear stress in solid and hollow shafts are given the same. Hence torque transmitted by solid shaft is equal to the torque transmitted by hollow shaft. But the torque transmitted by hollow shaft is given by equation (16.6).

∴ Using equation (16.6),

$$\begin{aligned} T &= \frac{\pi}{16} \times \tau \times \frac{(D_0^4 - D_i^4)}{D_0} \\ &= \frac{\pi}{16} \times 800 \times \frac{[D_0^4 - (0.6 D_0)^4]}{D_0} \quad (\because D_i = 0.6 D_0) \\ &= \pi \times 50 \times \frac{[D_0^4 - (0.6 D_0)^4]}{D_0} \end{aligned}$$

But torque transmitted by solid shaft

$$= 28647800 \text{ Nmm}$$

∴ Equating the two torques, we get

$$28647800 = \pi \times 50 \times \left( \frac{0.8704 D_0^4}{D_0} \right) = \pi \times 50 \times 0.8704 D_0^3$$

$$\therefore D_0 = \left( \frac{28647800}{\pi \times 50 \times 0.8704} \right)^{1/3} = 127.6 \text{ mm} = \text{say } 128 \text{ mm}$$

$$\therefore \text{Internal dia. } D_i = 0.6 \times D_0 = 0.6 \times 128 = 76.8 \text{ mm}$$

Now let  $W_s$  = Weight of solid shaft,

$W_h$  = Weight of hollow shaft.

Then  $W_s$  = Weight density  $\times$  Area of solid shaft  $\times$  Length

$$= w \times \frac{\pi}{4} D^2 \times L \quad (\text{where } w = \text{weight density})$$

Similarly  $W_h$  = Weight density  $\times$  Area of hollow shaft  $\times$  Length

$$= w \times \frac{\pi}{4} [D_0^2 - D_i^2] \times L$$

(∵ Both shafts are of same lengths and of same material)

Now percent saving in weight

$$= \frac{W_s - W_h}{W_s} \times 100$$

$$= \frac{w \times \frac{\pi}{4} D^2 \times L - w \times \frac{\pi}{4} [D_0^2 - D_i^2] \times L}{w \times \frac{\pi}{4} D^2 \times L} \times 100$$

$$= \frac{D^2 - (D_0^2 - D_i^2)}{D^2} \times 100 \quad \left( \text{Cancelling } w \times \frac{\pi}{4} \times L \right)$$

$$\begin{aligned} &= \frac{122^2 - (128^2 - 75.8^2)}{122^2} \times 100 = \frac{14884 - (16364 - 5898)}{14884} \times 100 \\ &= \frac{14884 - 10466}{14884} \times 100 = 29.55\% \quad \text{Ans.} \end{aligned}$$

**Problem 16.10.** A solid steel shaft has to transmit 75 kW at 200 r.p.m. Taking allowable shear stress as 70 N/mm<sup>2</sup>, find suitable diameter for the shaft, if the maximum torque transmitted at each revolution exceeds the mean by 30%. (AMIE, Summer 1978)

**Sol.** Given :

Power transmitted,  $P = 75 \text{ kW} = 75 \times 10^3 \text{ W}$

R.P.M. of the shaft,  $N = 200$

Shear stress,  $\tau = 70 \text{ N/mm}^2$

Let  $T$  = Mean torque transmitted

$T_{max}$  = Maximum torque transmitted = 1.3  $T$

$D$  = Suitable diameter of the shaft

Power is given by the relation,

$$P = \frac{2\pi NT}{60}$$

$$\text{or } 75 \times 10^3 = \frac{2\pi \times 200 \times T}{60}$$

$$\therefore T = \frac{75 \times 10^3 \times 60}{2\pi \times 200} = 3580.98 \text{ Nm} = 3580980 \text{ Nmm}$$

$$\therefore T_{max} = 1.3 T = 1.3 \times 3580980 = 4655274 \text{ Nmm.}$$

Maximum torque transmitted by a solid shaft is given by equation (16.4) as,

$$T_{max} = \frac{\pi}{16} \times \tau \times D^3$$

$$\text{or } 4655274 = \frac{\pi}{16} \times 70 \times D^3$$

$$\therefore D = \left( \frac{16 \times 4655274}{\pi \times 70} \right)^{1/3} = 69.57 \text{ mm} \approx 70 \text{ mm.} \quad \text{Ans.}$$

**Problem 16.11.** A hollow shaft is to transmit 300 kW power at 80 r.p.m. If the shear stress is not to exceed 60 N/mm<sup>2</sup> and the internal diameter is 0.6 of the external diameter, find the external and internal diameters assuming that the maximum torque is 1.4 times the mean. (AMIE, Winter 1986)

**Sol.** Given :

Power transmitted,  $P = 300 \text{ kW} = 300 \times 10^3 \text{ W}$

Speed of the shaft,  $N = 80 \text{ r.p.m.}$

Maximum shear stress,  $\tau = 60 \text{ N/mm}^2$

Internal diameter,  $D_i = 0.6 \times \text{External diameter} = 0.6 D_0$

Maximum torque,  $T_{max} = 1.4 \text{ times the mean torque} = 1.4 \times T$

Power is given by the relation,

$$P = \frac{2\pi NT}{60}$$

or  $T = \frac{60 \times P}{2\pi N} = \frac{60 \times 300 \times 10^3}{2\pi \times 80} = 35809.8 \text{ Nm}$   
 $\therefore T_{max} = 1.4 T = 1.4 \times 35809.8 \text{ Nm} = 50133.7 \text{ Nm} = 50133700 \text{ Nmm.}$   
 Now maximum torque transmitted by a hollow shaft is given by equation (16.6) as,

$$T_{max} = \frac{\pi}{16} \times \tau \times \left[ \frac{D_0^4 - D_i^4}{D_0} \right]$$

$$50133700 = \frac{\pi}{16} \times 60 \times \left[ \frac{D_0^4 - (0.6D_0)^4}{D_0} \right]$$

$$= \frac{\pi}{16} \times 60 \left[ \frac{D_0^4 - .1296D_0^4}{D_0} \right] = \frac{\pi}{16} \times 60 \times .8704 D_0^3$$

$$\therefore D_0 = \left( \frac{16 \times 50133700}{\pi \times 60 \times .8704} \right)^{1/3} = 169.2 \approx 170 \text{ mm. Ans.}$$

and

$$D_i = 0.6 \times D_0 = 0.6 \times 170 = 102 \text{ mm. Ans.}$$

**Problem 16.12.** A hollow shaft, having an inside diameter 60% of its outer diameter, is to replace a solid shaft transmitting the same power at the same speed. Calculate the percentage saving in material, if the material to be used is also the same.

**Sol.** Given :

Let  $D_0$  = Outer diameter of the hollow shaft

$D_i$  = Inside diameter of the hollow shaft = 60% of  $D_0$

$$= \frac{60}{100} \times D_0 = 0.6 D_0$$

$D$  = Diameter of the solid shaft

$P$  = Power transmitted by hollow shaft or by solid shaft

$N$  = Speed of each shaft

$\tau$  = Maximum shear stress induced in each shaft. Since material of both shafts is same and hence shear stress will be same.

Power by solid shaft or hollow shaft is given by

$$P = \frac{2\pi NT}{60}$$

$$\therefore T = \frac{60 \times P}{2\pi N} = \text{constant}$$

( $\because P$  and  $N$  are same for solid and hollow shafts)

$\therefore$  Torque transmitted by solid shaft is the same as the torque transmitted by hollow shaft.

Torque transmitted by solid shaft is given by equation (16.4) as

$$T = \frac{\pi}{16} \tau D^3 \quad \dots(i)$$

Torque transmitted by hollow shaft is given by equation (16.6) as

$$T = \frac{\pi}{16} \tau \left[ \frac{D_0^4 - D_i^4}{D_0} \right] = \frac{\pi}{16} \tau \left[ \frac{D_0^4 - (.6D_0)^4}{D_0} \right]$$

$$= \frac{\pi}{16} \tau \left[ \frac{D_0^4 - 0.1296D_0^4}{D_0} \right] = \frac{\pi}{16} \tau \times 0.8704 D_0^3 \quad \dots(ii)$$

Since torque transmitted is the same and hence equating equations (i) and (ii)

$$\frac{\pi}{16} \tau D^3 = \frac{\pi}{16} \tau \times 0.8704 D_0^3$$

$$\therefore D = (0.8704)^{1/3} D_0 = 0.9548 D_0$$

$$\therefore \text{Area of solid shaft} = \frac{\pi}{4} D^2 = \frac{\pi}{4} (0.9548 D_0)^2 = 0.716 D_0^2$$

$$\text{Area of hollow shaft} = \frac{\pi}{4} [D_0^2 - D_i^2] = \frac{\pi}{4} [D_0^2 - (0.6D_0)^2]$$

$$= \frac{\pi}{4} [D_0^2 - 0.36D_0^2] = \frac{\pi}{4} \times 0.64 D_0^2 = 0.502 D_0^2$$

For the shafts of the same material, the weight of the shafts is proportional to the areas.

$\therefore$  Saving in material = Saving in area

$$= \frac{\text{Area of solid shaft} - \text{Area of hollow shaft}}{\text{Area of solid shaft}}$$

$$= \frac{0.716 D_0^2 - 0.502 D_0^2}{0.716 D_0^2} = 0.2988$$

$\therefore$  Percentage saving in material =  $0.2988 \times 100 = 29.88$ . Ans.

## 16.6. EXPRESSION FOR TORQUE IN TERMS OF POLAR MOMENT OF INERTIA

Polar moment of inertia of a plane area is defined as the moment of inertia of the area about an axis perpendicular to the plane of the figure and passing through the C.G. of the area. It is denoted by symbol  $J$ .

The torque in terms of polar moment of inertia ( $J$ ) is obtained from equation [16.3 (A)] of Art. 16.3.

The moment ( $dT$ ) on the circular ring is given by equation [16.3 (A)] as

$$dT = \frac{\tau}{R} 2\pi r^3 dr = \frac{\tau}{R} 2\pi r \times r^2 dr = \frac{\tau}{R} r^2 \times 2\pi r \times dr$$

$$= \frac{\tau}{R} r^2 dA \quad (\because dA = 2\pi r dr \text{ see Fig. 16.3})$$

$$\therefore \text{Total torque, } T = \int_0^R dT = \int_0^R \frac{\tau}{R} r^2 dA = \frac{\tau}{R} \int_0^R r^2 dA \quad \dots(i)$$

But  $\int_0^R r^2 dA$  = Moment of inertia of the elementary ring about an axis perpendicular to the plane of Fig. 16.3 and passing through the centre of the circle.

$$\therefore \int_0^R r^2 dA = \text{Moment of inertia of the circle about an axis perpendicular to the plane of the circle and passing through the centre of the circle}$$

$$= \text{Polar moment of inertia } (J) = \frac{\pi}{32} D^4$$

Hence equation (i) becomes as

$$T = \frac{\tau}{R} \times J \quad \left( \because J = \int_0^R r^2 dA \right)$$

$$\therefore \frac{T}{J} = \frac{\tau}{R} \quad \dots(16.8)$$

But from equation (16.1), we have

$$\frac{\tau}{R} = \frac{C\theta}{L}$$

$$\therefore \frac{T}{J} = \frac{\tau}{R} = \frac{C\theta}{L} \quad \dots(16.9)$$

where  $C$  = Modulus of rigidity  
 $\theta$  = Angle of twist in radiation  
 $L$  = Length of the shaft.

### 16.7. POLAR MODULUS

Polar modulus is defined as the ratio of the polar moment of inertia to the radius of the shaft. It is also called torsional section modulus. It is denoted by  $Z_p$ . Mathematically,

$$Z_p = \frac{J}{R}$$

$$(a) \text{ For a solid shaft, } J = \frac{\pi}{32} D^4$$

$$\therefore Z_p = \frac{\frac{\pi}{32} D^4}{\frac{D}{2}} = \frac{\pi D^4}{32} \times \frac{2}{D} = \frac{\pi}{16} D^3 \quad \dots(16.10)$$

$$(b) \text{ For a hollow shaft, } J = \frac{\pi}{32} (D_o^4 - D_i^4) \quad \dots(16.11)$$

$$\therefore Z_p = \frac{\frac{\pi}{32} [D_o^4 - D_i^4]}{R} \quad (\text{Here } R \text{ is the outer radius})$$

$$\left( \because R = \frac{D_o}{2} \right)$$

$$= \frac{\frac{\pi}{32} [D_o^4 - D_i^4]}{D_o/2} = \frac{\pi}{16D_o} \times [D_o^4 - D_i^4] \quad \dots(16.12)$$

### 16.8. STRENGTH OF A SHAFT AND TORSIONAL RIGIDITY

The strength of a shaft means the *maximum torque* or *maximum power* the shaft can transmit.

Torsional rigidity or stiffness of the shaft is defined as the product of modulus of rigidity ( $C$ ) and polar moment of inertia of the shaft ( $J$ ). Hence mathematically, the torsional rigidity is given as,

$$\text{Torsional rigidity} = C \times J.$$

Torsional rigidity is also defined as the torque required to produce a twist of one radian per unit length of the shaft.

Let a twisting moment  $T$  produces a twist of  $\theta$  radians in a shaft of length  $L$ .

Using equation (16.9), we have

$$\frac{T}{J} = \frac{C\theta}{L} \quad \text{or} \quad C \times J = \frac{T \times L}{\theta}$$

But  $C \times J =$  Torsional rigidity

$$\therefore \text{Torsional rigidity} = \frac{T \times L}{\theta}$$

If  $L =$  one metre and  $\theta =$  one radian

Then torsional rigidity = Torque.

**Problem 16.13.** Determine the diameter of a solid steel shaft which will transmit 90 kW at 160 r.p.m. Also determine the length of the shaft if the twist must not exceed  $1^\circ$  over the entire length. The maximum shear stress is limited to  $60 \text{ N/mm}^2$ . Take the value of modulus of rigidity =  $8 \times 10^4 \text{ N/mm}^2$ .

**Sol.** Given :

$$\text{Power, } P = 90 \text{ kW} = 90 \times 10^3 \text{ W}$$

$$\text{Speed, } N = 160 \text{ r.p.m.}$$

$$\text{Angle of twist, } \theta = 1^\circ \quad \text{or} \quad \frac{\theta}{180} \text{ radian} \quad \left( \because 1^\circ = \frac{\pi}{180} \text{ radian} \right)$$

$$\text{Max. shear stress, } \tau = 60 \text{ N/mm}^2$$

$$\text{Modulus of rigidity, } C = 8 \times 10^4 \text{ N/mm}^2$$

Let  $D =$  Diameter of the shaft and

$L =$  Length of the shaft.

(i) Diameter of the shaft

Using equation (16.7),

$$P = \frac{2\pi NT}{60}$$

$$\text{or} \quad 90 \times 10^3 = \frac{2\pi \times 160 \times T}{60}$$

$$\therefore T = \frac{90 \times 10^3 \times 60}{2\pi \times 160} = 5371.48 \text{ N-m} = 5371.48 \times 10^3 \text{ N-mm}$$

Now using equation (16.4),

$$T = \frac{\pi}{16} \tau D^3$$

$$\text{or} \quad 5371.48 \times 10^3 = \frac{\pi}{16} \times 60 \times D^3$$

$$\therefore D^3 = \frac{5371.48 \times 10^3 \times 16}{\pi \times 60} = 455945$$

$$\therefore D = (455945)^{1/3} = 76.8 \text{ mm. Ans.}$$

(ii) Length of the shaft

Using equation (16.7),

$$\frac{\tau}{R} = \frac{C\theta}{L}$$



$$\text{or } \left(\frac{76.8}{2}\right) = \frac{8 \times 10^4 \times \pi}{L \times 180} \quad \left(\because R = \frac{D}{2} = \frac{76.8}{2} \text{ mm, } \theta = \frac{\pi}{180} \text{ radian}\right)$$

$$\text{or } L = \frac{8 \times 10^4 \times \pi \times 76.8}{60 \times 180 \times 2} = 893.6 \text{ mm. Ans.}$$

**Problem 16.14.** Determine the diameter of a solid shaft which will transmit 300 kW at 250 r.p.m. The maximum shear stress should not exceed 30 N/mm<sup>2</sup> and twist should not be more than 1° in a shaft length of 2 m. Take modulus of rigidity = 1 × 10<sup>5</sup> N/mm<sup>2</sup>.

**Sol.** Given :

Power transmitted,  $P = 300 \text{ kW} = 300 \times 10^3 \text{ W}$

Speed of the shaft,  $N = 250 \text{ r.p.m.}$

Maximum shear stress,  $\tau = 30 \text{ N/mm}^2$

Twist in shaft,  $\theta = 1^\circ = \frac{\pi}{180} = 0.01745 \text{ radian}$

Length of shaft,  $L = 2 \text{ m} = 2000 \text{ mm}$

Modulus of rigidity,  $C = 1 \times 10^5 \text{ N/mm}^2$

Let  $D =$  Diameter of the shaft.

Power is given by the relation,

$$P = \frac{2\pi NT}{60}$$

$$\text{or } 300 \times 10^3 = \frac{2\pi \times 250 \times T}{60}$$

$$\therefore T = \frac{300 \times 10^3 \times 60}{2\pi \times 250} = 11459.1 \text{ N-m} = 11459.1 \times 10^3 \text{ N-mm}$$

(i) Diameter of the shaft when maximum shear stress,

$$\tau = 30 \text{ N/mm}^2$$

Maximum torque transmitted by a solid shaft is given by equation (16.4) as

$$T = \frac{\pi}{16} \times \tau \times D^3$$

$$\therefore 11459100 = \frac{\pi}{16} \times 30 \times D^3$$

$$\therefore D = \left(\frac{16 \times 11459100}{\pi \times 30}\right)^{1/3} = 124.5 \text{ mm} \quad \dots(i)$$

(ii) Diameter of shaft when twist should not be more than 1°.

Using equation (16.9),

$$\frac{T}{J} = \frac{C\theta}{L}$$

where  $J =$  Polar moment of inertia of solid shaft

$$= \frac{\pi}{32} D^4$$

$$\therefore \frac{11459100}{\frac{\pi}{32} D^4} = \frac{10^5 \times 0.01745}{2000}$$

$$\therefore D^4 = \frac{32 \times 2000 \times 11459100}{10^5 \times \pi \times 0.01745} = 13377.81 \times 10^4$$

$$\therefore D = (13377.81 \times 10^4)^{1/4} = 107.5 \text{ mm} \quad \dots(ii)$$

The suitable diameter of the shaft is the greater\* of the two values given by equations (i) and (ii).

$$\therefore \text{Diameter of the shaft} = 124.5 \text{ mm say } 125 \text{ mm. Ans.}$$

\*If diameter is taken smaller of the two values say 107.5 mm, then from equation

$$T = \frac{\pi}{16} \tau D^3, \text{ the value of shear stress will be}$$

$$11459100 = \frac{\pi}{16} \tau \times (107.5)^3$$

$$\text{or } 11459100 = 243920 \tau$$

$$\text{or } \tau = \frac{11459100}{243920} = 46.978 \text{ N/mm}^2$$

which is more than the given value of 30 N/mm<sup>2</sup>).

**Problem 16.15.** A hollow shaft of diameter ratio  $\frac{3}{8}$  (internal dia. to outer dia.) is to transmit 375 kW power at 100 r.p.m. The maximum torque being 20% greater than the mean. The shear stress is not to exceed 60 N/mm<sup>2</sup> and twist in a length of 4 m not to exceed 2°. Calculate its external and internal diameters which would satisfy both the above conditions. Assume modulus of rigidity,  $C = 0.85 \times 10^5 \text{ N/mm}^2$ . (AMIE, Summer 1988 Converted to S.I. units)

**Sol.** Given :

Diameter ratio,  $\frac{D_i}{D_o} = \frac{3}{8}$

$$\therefore D_i = \frac{3}{8} D_o$$

Power,  $P = 375 \text{ kW} = 375000 \text{ W}$

Speed,  $N = 100 \text{ r.p.m.}$

Max. torque,  $T_{max} = 1.2 T_{mean}$

Length,  $L = 4 \text{ m} = 4000 \text{ mm}$

Max. twist,  $\theta = 2^\circ = 2 \times \frac{\pi}{180} \text{ radians} = 0.0349 \text{ radians}$

Modulus of rigidity,  $C = 0.85 \times 10^5 \text{ N/mm}^2$

Power is given by,  $P = \frac{2\pi NT}{60}$  Here torque is  $T_{mean}$

$$\text{or } T = \frac{P \times 60}{2\pi N} = \frac{375000 \times 60}{2\pi \times 100} = 35810 \text{ Nm}$$

$$\text{or } T_{mean} = 35810 \text{ Nm}$$

$$\therefore T_{max} = 1.2 \times T_{mean} = 1.2 \times 35810 = 42972 \text{ Nm} = 42972 \times 1000 \text{ Nmm.}$$

(i) *Diameters of the shaft when shear stress is not to exceed 60 N/mm<sup>2</sup>.*

For the hollow shaft, the torque transmitted is given by

$$T_{max} = \frac{\pi}{16} \times \tau \times \frac{(D_0^4 - D_i^4)}{D_0}$$

$$42972 \times 1000 = \frac{\pi}{16} \times 60 \times \frac{\left[ D_0^4 - \left( \frac{3}{8} D_0 \right)^4 \right]}{D_0}$$

$$\frac{42972000 \times 16}{\pi \times 60} = \frac{D_0^4}{D_0} \left( 1 - \frac{81}{4096} \right) = D_0^3 \times \frac{4015}{4096}$$

$$D_0^3 = \frac{42972000 \times 16 \times 4096}{\pi \times 60 \times 4015}$$

$$D_0 = \left( \frac{42972000 \times 16 \times 4096}{\pi \times 60 \times 4015} \right)^{1/3} = 154.97 \text{ mm say } 155 \text{ mm}$$

$$D_i = \frac{3}{8} D_0 = \frac{3}{8} \times 155 \approx 58.1 \text{ mm.}$$

(ii) *Diameters of the shaft when the twist is not to exceed 2 degrees.*

Using equation (16.9) in terms of torque and  $\theta$ , we get

$$\frac{T}{J} = \frac{C \times \theta}{L}$$

$$\frac{42972000}{\frac{\pi}{32} [D_0^4 - D_i^4]} = \frac{(0.85 \times 10^5) \times 0.0349}{4000}$$

$$\frac{42972000 \times 4000 \times 32}{\pi \times 0.85 \times 10^5 \times 0.0349} = D_0^4 - D_i^4 = D_0^4 - \left( \frac{3}{8} D_0 \right)^4 = D_0^4 - \frac{81}{4096} D_0^4$$

$$= D_0^4 \left[ 1 - \frac{81}{4096} \right] = \frac{4015}{4096} D_0^4$$

$$D_0^4 = \frac{42972000 \times 4000 \times 32 \times 4096}{\pi \times 0.85 \times 10^5 \times 0.0349 \times 4015}$$

$$D_0 = 156.65 \text{ mm say } 157 \text{ mm}$$

$$D_i = \frac{3}{8} \times 156.65 = 58.74 \text{ mm say } 59 \text{ mm.}$$

The diameters of the shaft, which would satisfy both the conditions are the greater of the two values.

∴ External dia.,  $D_0 = 157 \text{ mm. Ans.}$

Internal dia.,  $D_i = 59 \text{ mm. Ans.}$

**Problem 16.16.** A solid circular shaft transmits 75 kW power at 200 r.p.m. Calculate the shaft diameter, if the twist in the shaft is not to exceed 1° in 2 metres length of shaft, and shear stress is limited to 50 N/mm<sup>2</sup>. Take  $C = 1 \times 10^5 \text{ N/mm}^2$ .

**Sol.** Given :

Power transmitted,  $P = 75 \text{ kW} = 75 \times 10^3 \text{ W}$

Speed of the shaft,  $N = 200$

Twist in the shaft,  $\theta = 1^\circ$

$$= \frac{\pi}{180} \text{ radians} = 0.01745 \text{ rad.}$$

Length of the shaft,  $L = 2 \text{ m} = 2000 \text{ mm}$

Maximum shear stress,  $\tau = 50 \text{ N/mm}^2$

Modulus of rigidity,  $C = 1 \times 10^5 \text{ N/mm}^2$

$$P = \frac{2\pi NT}{60} \text{ or } 75 \times 10^3 = \frac{2\pi \times 200 \times T}{60}$$

$$T = \frac{75 \times 10^3 \times 60}{2\pi \times 200} = 3580.98 \text{ Nm} = 3580980 \text{ Nmm.}$$

(i) *Diameter of the shaft when maximum shear stress is limited to 50 N/mm<sup>2</sup>.*

Using equation (16.4),

$$T = \frac{\pi}{16} \tau D^3 \text{ or } 3580980 = \frac{\pi}{16} \times 50 \times D^3.$$

$$D = \left( \frac{16 \times 3580980}{\pi \times 50} \right)^{1/3} = 71.3 \text{ mm} \quad \dots(i)$$

(ii) *Diameter of the shaft when the twist in the shaft is not to exceed 1°.*

Using equation (16.9),

$$\frac{T}{J} = \frac{C\theta}{L}$$

$$\text{or } \frac{3580980}{\frac{\pi}{32} D^4} = \frac{10^5 \times 0.01745}{2000} \quad \left( \because J = \frac{\pi}{32} D^4 \right)$$

$$D = \left( \frac{32 \times 2000 \times 3580980}{\pi \times 10^5 \times 0.01745} \right)^{1/4} = 80.4 \text{ mm.} \quad \dots(ii)$$

The suitable diameter of the shaft is the greater value of the two diameters given by equations (i) and (ii) i.e., 80.4 mm say 81 mm. **Ans.**

**Problem 16.17.** A hollow shaft, having an internal diameter 40% of its external diameter, transmits 562.5 kW power at 100 r.p.m. Determine the external diameter of the shaft if the shear stress is not to exceed 60 N/mm<sup>2</sup> and the twist in a length of 2.5 m should not exceed 1.3 degrees. Assume maximum torque = 1.25 mean torque and modulus of rigidity =  $9 \times 10^4 \text{ N/mm}^2$ .

**Sol.** Given :

Internal diameter,  $D_i = 40\%$  of external diameter,  $(D_0) = 0.40 D_0$

Power transmitted,  $P = 562.5 \text{ kW} = 562.5 \times 10^3 \text{ W}$

Speed of the shaft,  $N = 100 \text{ r.p.m.}$

Maximum shear stress,  $\tau = 60 \text{ N/mm}^2$

Twist in the shaft,  $\theta = 1.3^\circ = 1.3 \times \frac{\pi}{180} \text{ radians} = 0.02269 \text{ rad}$

Length of shaft,  $L = 2.5 \text{ m} = 2500 \text{ mm}$

Maximum torque,  $T_{max} = 1.25 \times T_{mean}$   
 Modulus of rigidity,  $C = 9 \times 10^4 \text{ N/mm}^2$   
 The horse power transmitted is given by

$$P = \frac{2\pi NT}{60}$$

or  $562.5 \times 10^3 = \frac{2\pi \times 100 \times T_{mean}}{60}$  ( $\because$  Here  $T = T_{mean}$ )

or  $T_{mean} = \frac{60 \times 562.5 \times 10^3}{2\pi \times 100} = 53714.7 \text{ Nm} = 53714700 \text{ Nmm}$

$\therefore T_{max} = 1.25 \times T_{mean} = 1.25 \times 53714700 = 67143375 \text{ Nmm}$ .

(i) Diameter of the hollow shaft when maximum shear stress is  $60 \text{ N/mm}^2$ .

Using equation (16.6) for torque in case of hollow shaft

$$T = \frac{\pi}{16} \tau \left[ \frac{D_0^4 - D_i^4}{D_0} \right]$$

where  $T = T_{max} = 67143375$  and  $D_i = 0.4 D_0$ ,  $\tau = 60 \text{ N/mm}^2$

$$\therefore 67143375 = \frac{\pi}{16} \times 60 \left[ \frac{D_0^4 - (0.4D_0)^4}{D_0} \right]$$

$$= \frac{\pi}{16} \times 60 \left[ \frac{D_0^4 - 0.0256D_0^4}{D_0} \right]$$

$$= \frac{\pi}{16} \times 60 \times 0.9744D_0^3 = 11.479D_0^3$$

$$\therefore D_0 = \left( \frac{67143375}{11.479} \right)^{1/3} = 179.6 \text{ mm} \quad \dots(i)$$

(ii) Diameter of the shaft when the twist in the hollow shaft is not to exceed  $1.3^\circ$ .

Using equation (16.9), we have

$$\frac{T}{J} = \frac{C\theta}{L} \quad \dots(ii)$$

where  $T = T_{max} = 67143375$ ,  $\theta = 1.3^\circ = 0.02269 \text{ rad}$ ,  $L = 2500 \text{ mm}$ ,  $C = 9 \times 10^4 \text{ N/mm}^2$   
 and  $J = \text{Polar moment of inertia for hollow shaft}$

$$= \frac{\pi}{32} [D_0^4 - D_i^4] \quad (\text{see equation 16.11})$$

$$= \frac{\pi}{32} [D_0^4 - (0.4D_0)^4] \quad (\because D_i = 0.4D_0)$$

$$= \frac{\pi}{32} \times 0.9744 D_0^4 = 0.09566 D_0^4.$$

Substituting these values in equation (ii), we get

$$\frac{67143375}{0.09566D_0^4} = \frac{9 \times 10^4 \times 0.02269}{2500}$$

$$\therefore D_0^4 = \frac{2500 \times 67143375}{0.09566 \times 9 \times 10^4 \times 0.02269} = 85928.215 \times 10^4$$

$$\therefore D_0 = 85928.215 \times 10^4 = 171.2 \text{ mm} \quad \dots(iii)$$

The external diameter of the shaft should be  $179.6 \text{ mm}$  say  $180 \text{ mm}$  (i.e., greater of the two values given by equations (i) and (iii)). **Ans.**

### 16.9. FLANGED COUPLING

A flange coupling is used to connect two shafts. Fig. 16.5 shows such a coupling.

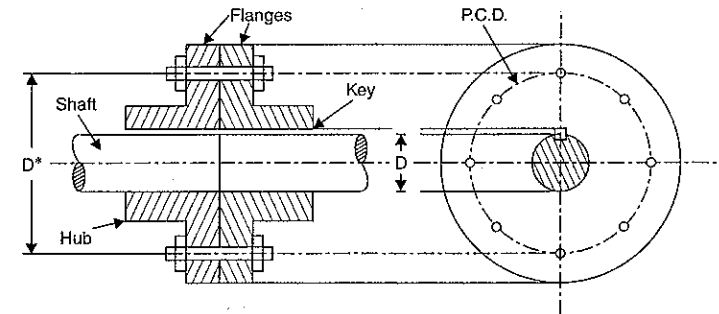

Fig. 16.5

The flanges of the two shafts are joined together by bolts and nuts (or rivets) and torque is then transferred from one shaft to another through the bolts. Connection between each shaft and coupling is provided by the key. The bolts are arranged along a circle called the pitch circle. The bolts are subjected to shear stress when torque is transmitted from one shaft to another.

Let  $\tau = \text{Shear stress in the shaft}$

$q = \text{Shear stress in the bolt}$

$d = \text{Diameter of bolt}$

$D = \text{Diameter of shaft}$

$D^* = \text{Diameter of bolt pitch circle}$

$n = \text{Number of bolts}$

Maximum load that can be resisted by one bolt

$$= \text{Stress in bolt} \times \text{Area of one bolt} = q \times \frac{\pi}{4} d^2$$

Torque resisted by one bolt = Load resisted by one bolt  $\times$  Radius of pitch circle

$$= q \times \frac{\pi}{4} d^2 \times \frac{D^*}{2}$$

$\therefore$  Total torque resisted by  $n$  bolts

$$= n \times q \times \frac{\pi}{4} d^2 \times \frac{D^*}{2} = n \times q \times \frac{\pi d^2 \times D^*}{8} \quad \dots(i)$$

But the torque transmitted by the shaft,

$$T = \frac{\pi}{16} \tau \times D^3 \quad \dots(ii)$$

Since the torque resisted by the bolts should be equal to the torque transmitted by the shafts, therefore equating (i) and (ii), we get

$$n \times q \times \frac{\pi d^2 \times D^*}{8} = \frac{\pi}{16} \times \tau \times D^3$$

From the above equation the unknown value of any parameter (say number of bolts or diameter of bolt) can be calculated.

**Problem 16.18.** Two shafts are connected end to end by means of a flanged coupling in which there are 12 bolts, the pitch circle diameter being 25 cm. The maximum shear stress is limited to 55 N/mm<sup>2</sup> in the shafts and 20 N/mm<sup>2</sup> in the bolts. If one shaft is solid of 5 cm diameter and the other is hollow of 10 cm external diameter, calculate the internal diameter of the hollow shaft and the bolt diameter so that both shafts and the coupling are all equally strong in torsion. (AMIE, Summer 1983)

**Sol. Given :**

Number of bolts,  $n = 12$   
 Pitch circle diameter = 25 cm = 250 mm  
 Maximum shear stress in the shaft,  
 $\tau = 55 \text{ N/mm}^2$   
 Maximum shear stress in the bolts,  
 $q = 20 \text{ N/mm}^2$   
 Dia. of solid shaft,  $D = 5 \text{ cm} = 50 \text{ mm}$   
 External dia. of hollow shaft,  
 $D_0 = 10 \text{ cm} = 100 \text{ mm}$   
 Let  $D_i$  = Internal dia. of hollow shaft  
 $d$  = Dia. of the bolt in mm.

In case of a coupling, the torque from one shaft to other shaft is transmitted through bolts. As the shafts and coupling are all equally strong in torsion, the torque transmitted by the solid shaft must be equal to the torque transmitted by the bolts which must be equal to the torque transmitted by hollow shaft.

The torque transmitted by solid shaft is given by equation (16.4).

$\therefore$  Using equation (16.4),

$$T = \frac{\pi}{16} \tau \times D^3 = \frac{\pi}{16} \times 55 \times 50^3 = 1349900 \text{ Nmm} \quad \dots(i)$$

$$\text{Area of one bolt} = \frac{\pi}{4} d^2 \quad (\because \text{Dia. of bolt} = d)$$

$$\text{Area of 12 bolts} = 12 \times \frac{\pi}{4} d^2$$

$$\begin{aligned} \text{Shear force in 12 bolts} &= \text{Shear stress in bolts} \times \text{Area of 12 bolts} \\ &= 20 \times 12 \times \frac{\pi}{4} d^2 = 60 \pi d^2 \text{ N} \end{aligned}$$

$$\begin{aligned} \text{Torque transmitted by the bolts} &= \text{Shear force in bolts} \times \frac{\text{Pitch circle dia.}}{2} \\ &= 60 \pi d^2 \times \frac{250}{2} \text{ Nmm} = 7500 \pi d^2 \text{ Nmm} \quad \dots(ii) \end{aligned}$$

Equating equations (i) and (ii), we get  
 $1349900 = 7500 \pi d^2$

$$d = \sqrt{\frac{1349900}{7500 \times \pi}} = \sqrt{57.3} = 7.57 \text{ mm. Ans.}$$

Torque transmitted by the hollow shaft is given by equation (16.6).

$\therefore$  Using equation (16.6),

$$\begin{aligned} T &= \frac{\pi}{16} \times \tau \times \left[ \frac{D_0^4 - D_i^4}{D_0} \right] \\ &= \frac{\pi}{16} \times 55 \times \left[ \frac{100^4 - D_i^4}{100} \right] \quad (\because \tau = 55, D_0 = 100) \\ &= 0.10799 \times (10^8 - D_i^4) \quad \dots(iii) \end{aligned}$$

Equating equations (i) and (iii),

$$1349900 = 0.10799 (10^8 - D_i^4)$$

$$\text{or} \quad D_i^4 = 10^8 - \frac{1349900}{0.10799} = 10^8 - 1250 \times 10^4 = 8750 \times 10^4$$

$$D_i = (8750 \times 10^4)^{1/4} = 96.72 \text{ mm. Ans.}$$

**Problem 16.19.** A shaft is to be fitted with a flanged coupling having 8 bolts on a circle of diameter 150 mm. The shaft may be subjected to either a direct tensile load of 400 kN or a twisting moment of 18 kNm. If the maximum direct and shearing stresses permissible in the bolt material are 125 N/mm<sup>2</sup> and 55 N/mm<sup>2</sup> respectively, find the minimum diameter of the bolt required. Assume that each bolt takes an equal share of the load or torque.

(AMIE, Summer 1985)

**Sol. Given :**

Number of bolts,  $n = 8$   
 Pitch circle diameter,  $D^* = 150 \text{ mm}$   
 $\therefore$  Radius of pitch circle =  $\frac{150}{2} = 75 \text{ mm}$   
 Direct tensile load,  $W = 400 \text{ kN} = 400 \times 10^3 \text{ N}$   
 Twisting moment,  $T = 18 \text{ kNm} = 18 \times 10^3 \text{ Nm}$   
 $= 18 \times 10^3 \times 10^3 \text{ Nmm} = 18 \times 10^6 \text{ Nmm}$   
 Maximum direct stress,  $p = 125 \text{ N/mm}^2$   
 Maximum shear stress,  $\tau = 55 \text{ N/mm}^2$   
 Let  $d$  = Diameter of bolt in mm

$$\text{Area of one bolt} = \frac{\pi}{4} d^2$$

$$\text{Area of 8 bolts} = 8 \times \frac{\pi}{4} d^2 = 2 \pi d^2 \text{ mm}^2.$$

First consider the strength of the bolt material from shearing effect.

$$\begin{aligned} \text{Max. shear force in 8 bolts} &= \text{Max. shear stress in bolts} \times \text{Area of 8 bolts} \\ &= 55 \times 2 \pi d^2 \text{ N.} \end{aligned}$$

$$\begin{aligned} \text{Torque transmitted by the bolts} &= \text{Shear force in bolts} \times \text{Radius of pitch circle} \\ &= 55 \times 2 \pi d^2 \times 75 \quad (\because \text{Radius} = 75 \text{ mm}) \\ &= 110 \times 75 \times \pi d^2 \text{ Nmm} \end{aligned}$$

But torque transmitted = Twisting moment  $T = 18 \times 10^6$  Nmm

Equating the two values of the torque,

$$110 \times 75 \times \pi d^2 = 18 \times 10^6$$

$$\therefore d^2 = \frac{18 \times 10^6}{110 \times 75 \times \pi} = 694.4$$

$$\therefore d = \sqrt{694.4} = 26.35 \text{ mm} \quad \dots(i)$$

Now consider the strength of the bolt material from direct tensile load.

$$\begin{aligned} \text{Max. tensile load in 8 bolts} &= \text{Max. tensile stress} \times \text{Area of 8 bolts} \\ &= 125 \times 2 \pi d^2 \text{ N} \end{aligned}$$

But direct tensile load,  $W = 400 \times 10^3$  N

$\therefore$  Equating the two values of direct tensile load

$$125 \times 2 \pi d^2 = 400000$$

$$d^2 = \frac{400000}{125 \times 2 \times \pi} = 509.3$$

or

$$\therefore d = \sqrt{509.3} = 22.56 \text{ mm} \quad \dots(ii)$$

Comparing the results of (i) and (ii), the minimum diameter of the bolt required is the maximum of the two values.

$\therefore$  Minimum diameter should be 26.35 mm. **Ans.**

### 16.10. STRENGTH OF A SHAFT OF VARYING SECTIONS

When a shaft is made up of different lengths and of different diameters, the torque transmitted by individual sections should be calculated first. The strength of such a shaft is the minimum value of these torques.

**Problem 16.20.** A shaft ABC of 500 mm length and 40 mm external diameter is bored, for a part of its length AB, to a 20 mm diameter and for the remaining length BC to a 30 mm diameter bore. If the shear stress is not to exceed 80 N/mm<sup>2</sup>, find the maximum power, the shaft can transmit at a speed of 200 r.p.m.

If the angle of twist in the length of 20 mm diameter bore is equal to that in the 30 mm diameter bore, find the length of the shaft that has been bored to 20 mm and 30 mm diameter.

**Sol.** Given :

Total length,  $L = 500$  mm

External dia.,  $D = 40$  mm

Let

$L_1 =$  Length of shaft AB

$d_1 =$  Internal dia. of AB

$= 20$  mm

$L_2 =$  Length of shaft BC

$d_2 =$  Internal dia. of BC

$= 30$  mm

$\tau =$  Maximum shear stress

$= 80$  N/mm<sup>2</sup>

$N =$  Speed = 200 r.p.m.

$T_1 =$  Torque transmitted by shaft AB

$T_2 =$  Torque transmitted by shaft BC.

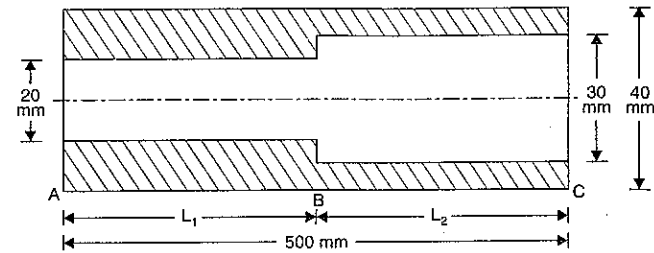

Fig. 16.6

The torque transmitted by a hollow shaft is given by equation (16.6) as

$$T = \frac{\pi}{16} \cdot \tau \cdot \left[ \frac{D_0^4 - D_i^4}{D_0} \right]$$

Hence the torque transmitted by hollow shaft AB is given by,

$$\begin{aligned} T_1 &= \frac{\pi}{16} \cdot \tau \cdot \left[ \frac{D^4 - D_i^4}{D} \right] \quad (\because \text{Here } D_0 = D, D_i = d_1) \\ &= \frac{\pi}{16} \times 80 \times \left[ \frac{40^4 - 20^4}{40} \right] \text{ Nmm} \\ &= 942500 \text{ Nmm} = 942.500 \text{ Nm.} \end{aligned}$$

Similarly torque transmitted by hollow shaft BC is given by,

$$\begin{aligned} T_2 &= \frac{\pi}{16} \cdot \tau \cdot \left[ \frac{D^4 - d_2^4}{D} \right] = \frac{\pi}{16} \times 80 \times \left[ \frac{40^4 - 30^4}{40} \right] \\ &= 687200 \text{ Nmm} = 687.2 \text{ Nm.} \end{aligned}$$

According to Art. 16.10, the safe torque transmitted by the complete shaft is the minimum of the above two torques.

$\therefore$  Safe torque ( $T$ ) transmitted by the shaft is 687.2 Nm

$\therefore T = 687.2$  Nm.

The power transmitted ( $P$ ) is given by equation (16.7) as

$$\begin{aligned} P &= \frac{2\pi NT}{60} \quad W = \frac{2\pi \times 200 \times 687.2}{60} = 14390 \text{ W} \\ &= 14.39 \text{ kW.} \quad \text{Ans.} \end{aligned}$$

Now from equation (16.9), we have

$$\frac{T}{J} = \frac{C \times \theta}{L} \quad \text{or} \quad \theta = \frac{T \cdot L}{C \cdot J}$$

The safe torque  $T$  and shear modulus ( $C$ ) are same for the given shaft.

Hence angle of twist in shaft AB =  $\frac{T \cdot L_1}{C \cdot J_1}$

and angle of twist in shaft BC =  $\frac{T \cdot L_2}{C \cdot J_2}$

But angle of twist in shaft AB = Angle of twist in shaft BC

$$\therefore \frac{T \cdot L_1}{C \cdot J_1} = \frac{T \cdot L_2}{C \cdot J_2}$$

$$\text{or } \frac{L_1}{J_1} = \frac{L_2}{J_2} \quad \dots(i)$$

where  $J$  is the polar moment of inertia. From equation (16.11), its value for a hollow shaft is given by

$$J = \frac{\pi}{32} [D_o^4 - D_i^4]$$

$$\therefore J_1 = \text{Polar moment of inertia for the shaft AB}$$

$$= \frac{\pi}{32} [40^4 - 20^4]$$

$$J_2 = \text{Polar moment of inertia for the shaft BC}$$

$$= \frac{\pi}{32} [40^4 - 30^4]$$

Substituting these values in equation (i), we get

$$\frac{L_1}{\frac{\pi}{32} [40^4 - 20^4]} = \frac{L_2}{\frac{\pi}{32} [40^4 - 30^4]}$$

$$\frac{L_1}{L_2} = \frac{(40^4 - 20^4)}{(40^4 - 30^4)} = 1.37$$

$$L_1 = 1.37 \times L_2 = 1.37 (500 - L_1)$$

$$(\because L_1 + L_2 = 500 \therefore L_2 = 500 - L_1)$$

$$= 1.37 \times 500 - 1.37 L_1$$

$$L_1 + 1.37 L_1 = 1.37 \times 500 \quad \text{or} \quad 2.37 L_1 = 1.37 \times 500$$

$$L_1 = \frac{1.37 \times 500}{2.37} = 289 \text{ mm. Ans.}$$

$$L_2 = 500 - 289 = 211 \text{ mm. Ans.}$$

**Problem 16.21.** A steel shaft ABCD having a total length of 2.4 m consists of three lengths having different sections as follows :

AB is hollow having outside and inside diameters of 80 mm and 50 mm respectively and BC and CD are solid, BC having a diameter of 80 mm and CD a diameter of 70 mm. If the angle of twist is the same for each section, determine the length of each section and the total angle of twist if the maximum shear stress in the hollow portion is 50 N/mm<sup>2</sup>. Take  $C = 8.2 \times 10^4$  Nmm<sup>2</sup>.

**Sol.** Given :

Total length of shaft,  $L = 2.4 \text{ m} = 2400 \text{ mm}$

Shaft AB : Length =  $L_1$

Outer dia.,  $D_1 = 80 \text{ mm}$

Inner dia.,  $d_1 = 50 \text{ mm}$

Shaft BC : Length =  $L_2$

Diameter,  $D_2 = 80 \text{ mm}$

Shaft CD : Length =  $L_3$

Diameter,  $D_3 = 70 \text{ mm}$

Angle of twist is same for each section.

Hence  $\theta_1 = \theta_2 = \theta_3$

Max. shear stress in hollow portion,

$$\tau_1 = 50 \text{ N/mm}^2$$

Value of  $C = 8.2 \times 10^4 \text{ N/mm}^2$

Polar moment of inertia of each shaft is given as :

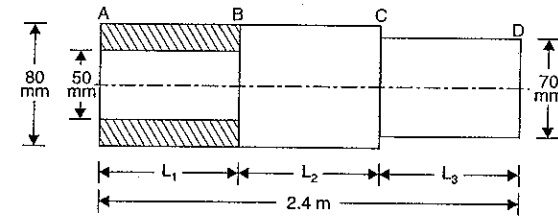

Fig. 16.7

$$\text{For shaft AB, } J_1 = \frac{\pi}{32} (D_1^4 - d_1^4) = \frac{\pi}{32} (80^4 - 50^4) = 340.9 \times 10^4 \text{ mm}^4$$

$$\text{For shaft BC, } J_2 = \frac{\pi}{32} D_2^4 = \frac{\pi}{32} \times 80^4 = 402.4 \times 10^4 \text{ mm}^4$$

$$\text{For shaft CD, } J_3 = \frac{\pi}{32} D_3^4 = \frac{\pi}{32} \times 70^4 = 235.8 \times 10^4 \text{ mm}^4$$

Now using equation,

$$\frac{T}{J} = \frac{C \times \theta}{L} \quad \text{or} \quad \theta = \frac{T \cdot L}{J \cdot C}$$

$$\text{Hence } \theta_1 = \frac{T \times L_1}{J_1 \times C}, \quad \theta_2 = \frac{T \times L_2}{J_2 \times C} \quad \text{and} \quad \theta_3 = \frac{T \times L_3}{J_3 \times C}$$

But  $\theta_1 = \theta_2 = \theta_3$

$$\therefore \frac{T \cdot L_1}{J_1 \cdot C} = \frac{T \cdot L_2}{J_2 \cdot C} = \frac{T \cdot L_3}{J_3 \cdot C} \quad [\text{Torque } T \text{ and } C \text{ are same for each portion}]$$

$$\text{or } \frac{L_1}{J_1} = \frac{L_2}{J_2} = \frac{L_3}{J_3}$$

$$\text{or } \frac{L_1}{340.9 \times 10^4} = \frac{L_2}{402.4 \times 10^4} = \frac{L_3}{235.8 \times 10^4}$$

$$\text{or } \frac{L_1}{340.9} = \frac{L_2}{402.4} = \frac{L_3}{235.8}$$

$$\therefore L_1 = \frac{340.9}{235.8} L_3 = 1.44 L_3 \quad \dots(i)$$

$$L_2 = \frac{402.4}{235.8} L_3 = 1.71 L_3 \quad \dots(ii)$$

But  $L_1 + L_2 + L_3 = 2.4 \text{ m} = 2400 \text{ mm}$   
 or  $1.44 L_3 + 1.71 L_3 + L_3 = 2400$  or  $4.15 L_3 = 2400$

$$\therefore L_3 = \frac{2400}{4.15} = 578.35 \text{ mm.}$$

Substituting the value of  $L_3$  in equations (i) and (ii), we get

$$L_1 = 1.44 \times 578.3 = 832.75 \text{ mm}$$

$$L_2 = 1.71 \times 578.3 = 988.80 \text{ mm}$$

As the shear stress is given in shaft  $AB$ . The angle of twist of shaft  $AB$  can be obtained by using equation

$$\frac{\tau}{R} = \frac{C \times \theta}{L}$$

$\therefore$  For shaft  $AB$ ,

$$\frac{\tau_1}{\left(\frac{D_1}{2}\right)} = \frac{C \times \theta_1}{L_1}$$

$$\therefore \theta_1 = \frac{\tau_1 \times L_1}{\left(\frac{D_1}{2}\right) \times C} = \frac{50 \times 832.75}{\left(\frac{80}{2}\right) \times 8.2 \times 10^4}$$

$$= 0.01269 \text{ radians} = 0.7273^\circ$$

$\therefore$  Total angle of twist of the whole shaft

$$= \theta_1 + \theta_2 + \theta_3 = 0.7273 \times 3 = 2.1819^\circ. \text{ Ans.}$$

**Problem 16.22.** A hollow shaft is 1 m long and has external diameter 50 mm. It has 20 mm internal diameter for a part of the length and 30 mm internal diameter for the rest of the length. If the maximum shear stress in it is not to exceed  $80 \text{ N/mm}^2$ , determine the maximum power transmitted by it at a speed of 300 r.p.m. If the twists produced in the two portions of the shafts are equal, find the lengths of the two portions. (AMIE, Winter 1984)

**Sol.** Given :

Total length,  $L = 1 \text{ m} = 1000 \text{ mm}$

External dia.,  $D_0 = 50 \text{ mm}$

Let  $L_1 =$  Length of the portion of the shaft whose internal dia. is 20 mm.

$L_2 =$  Length of the portion of the shaft whose internal dia. is 30 mm.  
 $= (1000 - L_1) \text{ mm}$

Maximum shear stress,

$$\tau = 80 \text{ N/mm}^2$$

Speed,  $N = 300 \text{ r.p.m.}$

Twists produced in the two portions of the shaft are given equal.

Using equation (16.9), we get

$$\frac{T}{J} = \frac{\tau}{R}$$

$$\therefore \tau = \frac{T}{J} \times R.$$

For a hollow shaft,  $R$  is the outer radius of the shaft. As the outer radius of the hollow shaft is

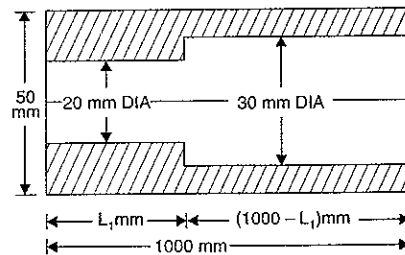

Fig. 16.8

same for both portions of the shaft, the shear stress will be maximum for the portion for which polar moment of inertia (i.e.,  $J$ ) is less. Polar moment of inertia for a hollow shaft is given by equation (16.11) as

$$J = \frac{\pi}{32} [D_0^4 - D_i^4]$$

$\therefore$  Polar moment of inertia of the portion having 20 mm internal diameter,

$$J_1 = \frac{\pi}{32} [50^4 - 20^4] \text{ mm}^4 \quad (\because D_0 = 50 \text{ mm}, D_i = 20 \text{ mm})$$

$$= \frac{\pi}{32} [6250000 - 160000] = 597884 \text{ mm}^4.$$

Similarly polar moment of inertia of the portion having 30 mm internal diameter,

$$J_2 = \frac{\pi}{32} [50^4 - 30^4] \text{ mm}^4$$

$$= \frac{\pi}{32} [6250000 - 810000] = 534070 \text{ mm}^4.$$

As the polar moment of inertia of the portion having 30 mm internal diameter is less, the maximum shear stress will develop in the portion of 30 mm internal diameter. Also maximum torque transmitted will be given by the portion of 30 mm internal diameter.

Now using equation (16.9),

$$\frac{T}{J} = \frac{\tau}{R}$$

$\therefore$  Maximum torque,

$$T = \frac{\tau}{R} \times J = \frac{80}{25} \times 534070 \quad \left(\because R = \frac{D_0}{2} = 25 \text{ mm}\right)$$

$$= 1709024 \text{ N-mm} = 1709.024 \text{ N-m} \quad (\because 1000 \text{ mm} = 1 \text{ m})$$

$\therefore$  Maximum power is given by equation (16.7) as

$$P = \frac{2\pi NT}{60} \text{ W} = \frac{2\pi \times 300 \times 1709.024}{60}$$

$$= 53688 \text{ W} = 53.688 \text{ kW. Ans.}$$

Lengths of the two portions

Using equation (16.9), we have

$$\frac{T}{J} = \frac{C\theta}{L} \quad \dots(i)$$

For the two portions the shear modulus ( $C$ ), the twist ( $\theta$ ) and torque  $T$  transmitted are equal.

For the portion having internal diameter 20 mm,

Polar moment of inertia,  $J_1 = 597884 \text{ mm}^4$ ,  $L_1 =$  Length.

Substituting these values in equation (i),

$$\therefore \frac{T}{J_1} = \frac{C\theta}{L_1} \quad \dots(ii)$$

For the portion having internal diameter 30 mm.

Polar moment of inertia,

$$J_2 = 534070 \text{ mm}^4$$

Length,  $L_2 = (1000 - L_1) \text{ mm.}$

Substituting these values in equation (i), we get

$$\frac{T}{J_2} = \frac{C\theta}{L_2} \quad \dots(iii)$$

Dividing equations (ii) and (iii),

$$\frac{J_2}{J_1} = \frac{L_2}{L_1}$$

$$\frac{534070}{597884} = \frac{1000 - L_1}{L_1} \quad [\because L_2 = (1000 - L_1) \text{ mm}]$$

$$\text{or} \quad 0.8932 = \frac{1000 - L_1}{L_1} \quad \text{or} \quad 0.8932 L_1 = 1000 - L_1$$

$$\text{or} \quad 0.8932 L_1 + L_1 = 1000 \quad \text{or} \quad 1.8932 L_1 = 1000$$

$$\text{or} \quad L_1 = \frac{1000}{1.8932} = 528.2 \text{ mm. Ans.}$$

$$\text{and} \quad L_2 = 1000 - L_1 = 1000 - 528.2 = 471.8 \text{ mm. Ans.}$$

**Problem 16.23.** Two solid shafts AB and BC of aluminium and steel respectively are rigidly fastened together at B and attached to two rigid supports at A and C. Shaft AB is 7.5 cm in diameter and 2 m in length. Shaft BC is 5.5 cm in diameter and 1 m in length. A torque of 20000 N-cm is applied at the junction B. Compute the maximum shearing stresses in each material. What is the angle of twist at the junction? Take modulus of rigidity of the materials as  $C_{Al} = 0.3 \times 10^5 \text{ N/mm}^2$  and  $C_{St} = 0.9 \times 10^5 \text{ N/mm}^2$ . (AMIE, Summer 1987)

**Sol.** Given :

Solid Shaft AB

Material = Aluminium

Length,  $L_1 = 2 \text{ m} = 2000 \text{ mm}$

Dia.,  $d_1 = 7.5 \text{ cm} = 75 \text{ mm}$

Modulus of rigidity,

$$C_1 = 0.3 \times 10^5 \text{ N/mm}^2$$

Torque at junction B,  $T = 20000 \text{ N cm}$

$$= 200000 \text{ Nmm.}$$

Solid Shaft BC

Material = Steel

Length,  $L_2 = 1 \text{ m} = 1000 \text{ mm}$

Dia.,  $d_2 = 5.5 \text{ cm} = 55 \text{ mm}$

Modulus of rigidity,

$$C_2 = 0.9 \times 10^5 \text{ N/mm}^2$$

The torque is applied at junction B, hence angle of twist in shaft AB and in shaft BC will be same (i.e.,  $\theta_1 = \theta_2 = \theta$ )

where  $\theta_1 =$  Angle of twist in shaft AB, and

$\theta_2 =$  Angle of twist in shaft BC.

Let  $T_1 =$  Torque transmitted to shaft AB, and

$T_2 =$  Torque transmitted to shaft BC

$$\therefore T_1 + T_2 = 20000 \text{ Nmm} \quad \dots(i)$$

Using equation (16.9), we get

$$\frac{T}{J} = \frac{C \times \theta}{L}$$

For the shaft AB, the above equation becomes as

$$\frac{T_1}{J_1} = \frac{C_1 \times \theta_1}{L_1}$$

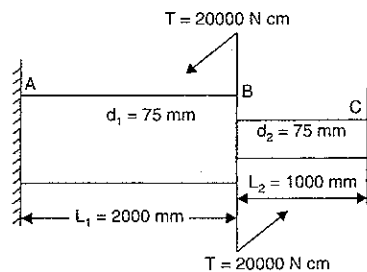

Fig. 16.8 (a)

$$\therefore \theta_1 = \frac{T_1 \times L_1}{J_1 \times C_1} \quad \text{where } J_1 = \frac{\pi}{32} d_1^4 = \frac{\pi}{32} \times 75^4$$

$$= \frac{T_1 \times 2000}{\frac{\pi}{32} \times 75^4 \times 0.3 \times 10^5} = \frac{T_1 \times 2000 \times 32}{\pi \times 75^4 \times 0.3 \times 10^5} \quad \dots(ii)$$

For the shaft BC, the value of  $\theta_2$  is given by,

$$\theta_2 = \frac{T_2 \times L_2}{J_2 \times C_2} \quad \text{where } J_2 = \frac{\pi}{32} d_2^4 = \frac{\pi}{32} \times 55^4$$

$$= \frac{T_2 \times 1000}{\frac{\pi}{32} \times 55^4 \times 0.9 \times 10^5} = \frac{T_2 \times 1000 \times 32}{\pi \times 55^4 \times 0.9 \times 10^5} \quad \dots(iii)$$

But

$$\theta_1 = \theta_2$$

$$\therefore \frac{T_1 \times 2000 \times 32}{\pi \times 75^4 \times 0.3 \times 10^5} = \frac{T_2 \times 1000 \times 32}{\pi \times 55^4 \times 0.9 \times 10^5}$$

$$\text{or} \quad \frac{2T_1}{75^4 \times 0.3} = \frac{T_2}{55^4 \times 0.9}$$

$$\text{or} \quad T_1 = \frac{75^4 \times 0.3}{55^4 \times 0.9 \times 2} T_2 = 0.576 T_2$$

Substituting this value in equation (i),

$$0.576 T_2 + T_2 = 200000$$

$$\text{or} \quad 1.576 T_2 = 200000$$

$$\therefore T_2 = \frac{200000}{1.576} = 126900 \text{ Nmm}$$

$$\text{But} \quad T_1 + T_2 = 200000$$

$$\therefore T_1 = 200000 - T_2 = 200000 - 126900 = 73100 \text{ Nmm.}$$

$$\text{From equation (16.9), } \frac{T}{J} = \frac{\tau}{R}$$

$$\text{For shaft AB} \quad \frac{T_1}{J_1} = \frac{\tau_1}{R_1}$$

$$\therefore \tau_1 = \frac{T_1 \times R_1}{J_1} = \frac{73100 \times 37.5}{\frac{\pi}{32} \times 75^4} \quad \left( \because R_1 = \frac{d_1}{2} = \frac{75}{2} = 37.5 \right)$$

$$= \frac{73100 \times 37.5 \times 32}{\pi \times 75^4} = 0.882 \text{ N/mm}^2. \text{ Ans.}$$

$$\text{For shaft BC} \quad \frac{T_2}{J_2} = \frac{\tau_2}{R_2}$$

$$\therefore \tau_2 = \frac{T_2 \times R_2}{J_2} = \frac{126900 \times 27.5}{\frac{\pi}{32} \times 55^4} \quad \left( \because R_2 = \frac{d_2}{2} = \frac{55}{2} = 27.5 \right)$$

$$= \frac{126900 \times 27.5 \times 32}{\pi \times 55^4} = 3.884 \text{ N/mm}^2. \text{ Ans.}$$



## 16.11. COMPOSITE SHAFT

A shaft made up of two or more different materials, and behaving as a single shaft is known as composite shaft. Hence in a composite shaft one type of shaft is rigidly seelved over another type of shaft. The total torque transmitted by a composite shaft is the sum of the torques transmitted by each individual shaft. But the angle of twist in each shaft will be equal.

**Problem 16.24.** A composite shaft consists of a steel rod 60 mm diameter surrounded by a closely fitting tube of brass. Find the out-side diameter of the tube so that when a torque of 1000 Nm is applied to the composite shaft, it will be shared equally by the two materials. Take  $C$  for steel =  $8.4 \times 10^4$  N/mm<sup>2</sup> and  $C$  for brass =  $4.2 \times 10^4$  N/mm<sup>2</sup>.

Find also the maximum shear stress in each material and common angle of twist in a length of 4 m.

**Sol.** Given :

Dia. of steel rod,  $d = 60$  mm

Torque,  $T = 1000$  Nm =  $1000 \times 10^3$  Nmm

Value of  $C$  for steel,  $C_s = 8.4 \times 10^4$  N/mm<sup>2</sup>

Value of  $C$  for brass,  $C_b = 4.2 \times 10^4$  N/mm<sup>2</sup>

Length of composite shaft,  $L = 4$  m = 4000 mm

Let  $D$  = Outside dia. of brass tube in mm

$\tau_s$  = Shear stress in steel

$\tau_b$  = Shear stress in brass

The inner dia. of brass tube will be equal to dia. of steel rod.

$\therefore$  Inner dia. of brass tube,

$$d = 60 \text{ mm}$$

Polar moment of inertia for steel rod is given by,

$$J_s = \frac{\pi}{32} d^4 = \frac{\pi}{32} \times 60^4 \text{ mm}^4$$

Polar moment of inertia for brass tube is given by,

$$J_b = \frac{\pi}{32} [D^4 - 60^4] \text{ mm}^4$$

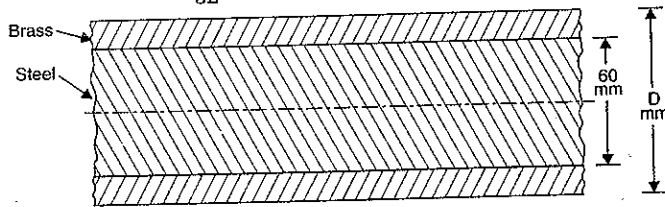

Fig. 16.9

Let  $T_s$  = Torque transmitted by steel rod, and

$T_b$  = Torque transmitted by brass tube.

But total torque,

$$T = T_s + T_b = T_s + T_s \quad (\because T_s = T_b \text{ given})$$

$$\therefore T_s = \frac{T}{2} = \frac{1000 \times 10^3}{2} \text{ Nmm} = 500 \times 10^3 \text{ Nmm}$$

and

$$T_b = T_s = 500 \times 10^3 \text{ Nmm}$$

Using equation (16.9), we have

$$\frac{T}{J} = \frac{C \times \theta}{L} \quad \text{or} \quad T = \frac{C \times \theta \times J}{L}$$

For steel rod, we have

$$T_s = \frac{C_s \times \theta_s \times J_s}{L_s} \quad \dots(i)$$

For brass tube, we have

$$T_b = \frac{C_b \times \theta_b \times J_b}{L_b} \quad \dots(ii)$$

But

$$T_s = T_b$$

Hence equating equations (i) and (ii), we get

$$\frac{C_s \times \theta_s \times J_s}{L_s} = \frac{C_b \times \theta_b \times J_b}{L_b}$$

But

$$L_s = L_b = L$$

Hence above equation becomes as

$$C_s \times \theta_s \times J_s = C_b \times \theta_b \times J_b$$

But in a composite shaft, the angle of twist in each shaft is same.

$\therefore \theta_s = \theta_b$

Now the above equation becomes as

$$C_s \times J_s = C_b \times J_b$$

$$\text{or} \quad 8.4 \times 10^4 \times \frac{\pi}{32} \times 60^4 = 4.2 \times 10^4 \times \frac{\pi}{32} [D^4 - 60^4]$$

$$\text{or} \quad \frac{8.4}{4.2} \times 60^4 = (D^4 - 60^4) \quad \text{or} \quad 2 \times 60^4 = D^4 - 60^4$$

$$\text{or} \quad 3 \times 60^4 = D^4 \quad \text{or} \quad (3)^{1/4} \times 60 = D$$

$$\text{or} \quad D = 78.98 \text{ mm} \approx 79 \text{ mm. Ans.}$$

(i) Shear stresses in each material

Using the equation,

$$\frac{T}{J} = \frac{\tau}{R} \quad \text{or} \quad \tau = \frac{T \times R}{J}$$

(a) For a steel rod, we have

$$\tau_s = \frac{T_s \times \left(\frac{d}{2}\right)}{J_s} \quad \left(\because R = \frac{d}{2}\right)$$

$$= \frac{500 \times 10^3 \times \left(\frac{60}{2}\right)}{\frac{\pi}{32} \times 60^4} = 117.9 \text{ N/mm}^2. \text{ Ans.}$$

(b) For a brass tube, we have

$$\tau_b = \frac{T_b \times \left(\frac{D}{2}\right)}{J_b} = \frac{500 \times 10^3 \times \left(\frac{79}{2}\right)}{\frac{\pi}{32} (D^4 - 60^4)}$$

$$= \frac{500 \times 10^3 \times 39.5}{\frac{\pi}{32} [79^4 - 60^4]} = 77.6 \text{ N/mm}^2. \text{ Ans.}$$

(ii) Common angle of twist

Using equation (i), we get

$$T_s = \frac{C_s \times \theta_s \times J_s}{L_s}$$

$$\text{or } \theta_s = \frac{T_s \times L_s}{C_s \times J_s} = \frac{500 \times 10^3 \times 4000}{8.4 \times 10^4 \times \frac{\pi}{32} \times 60^4} \quad (\because L_s = L = 4000)$$

$$= 0.01871 \text{ radians}$$

$$= 0.01871 \times \frac{180}{\pi} \text{ degrees} = 1.072^\circ.$$

But angle of twist in each shaft will be equal. The common angle to twist will be equal to the angle of twist in any shaft.

$\therefore$  Common angle of twist =  $1.072^\circ$ . Ans.

**Problem 16.25.** A composite shaft consists of copper rod of 30 mm diameter enclosed in a steel tube of external diameter 50 mm and 10 mm thick. The shaft is required to transmit a torque of 1000 Nm. Determine the shear stresses developed in copper and steel, if both the shafts have equal lengths and welded to a plate at each end, so that their twists are equal. Take modulus of rigidity for steel as twice that of copper.

**Sol.** Given :

Dia. of copper rod,  $d = 30 \text{ mm}$

External dia. of steel,  $D_0 = 50 \text{ mm}$

Internal dia. ( $D_i$ ) of steel shaft =  $D - 2 \times \text{Thickness}$   
 $= 50 - 2 \times 10 = 30 \text{ mm}$

$\therefore D_i = 30 \text{ mm}$

Total torque,  $T = 1000 \text{ Nm} = 1000 \times 10^3 \text{ Nmm}$

Let  $\tau_s$  = Shear stress in steel shaft

$\tau_c$  = Shear stress in copper

$C_s$  = Modulus of rigidity of steel

$C_c$  = Modulus of rigidity of copper

$L$  = Common length

$\theta$  = Common angle of twist =  $\theta_c = \theta_s$

$J_c$  = Polar moment of inertia of copper rod

$$= \frac{\pi}{32} \times d^4 = \frac{\pi}{32} \times 30^4 \text{ mm}^4$$

$J_s$  = Polar moment of inertia of steel shaft

$$= \frac{\pi}{32} [D_0^4 - D_i^4] = \frac{\pi}{32} [50^4 - 30^4] \text{ mm}^4$$

$$= \frac{\pi}{32} [125 \times 10^4 - 81 \times 10^4] = \frac{\pi}{32} \times 44 \times 10^4 \text{ mm}^4$$

$T_c$  = Torque transmitted by copper rod

$T_s$  = Torque transmitted by steel shaft.

Now for a composite shaft,

Total torque,

$$T = T_c + T_s$$

$$\text{or } T_c + T_s = 1000 \times 10^3 \quad (\because T = 1000 \times 10^3) \quad \dots(i)$$

Using the relation,

$$\frac{T}{J} = \frac{C \times \theta}{L} \text{ or } \theta = \frac{T \times L}{J \times C}$$

$$\text{For copper rod, } \theta_c = \frac{T_c \times L_c}{T_c \times C_c}$$

$$\text{For steel shaft, } \theta_s = \frac{T_s \times L_s}{T_s \times C_s}$$

$$\text{But } \theta_c = \theta_s \quad (\because \text{Angle of twist are same})$$

$$\therefore \frac{T_c \times L_c}{J_c \times C_c} = \frac{T_s \times L_s}{J_s \times C_s}$$

$$\text{But } L_c = L_s = L$$

Hence the above equation becomes as

$$\frac{T_c}{J_c \times C_c} = \frac{T_s}{J_s \times C_s}$$

$$\text{or } T_c = \frac{J_c}{J_s} \cdot \frac{C_c}{C_s} \cdot T_s = \frac{\frac{\pi}{32} \times 30^4}{\frac{\pi}{32} \times 44 \times 10^4} \times \frac{C_c}{2C_c} \times T_s \quad (\because C_s = 2C_c)$$

$$= \frac{81}{44} \times \frac{1}{2} \times T_s = \frac{81}{88} \times T_s$$

Substituting the value of  $T_c$  in equation (i), we get

$$\frac{81}{88} T_s + T_s = 1000,000$$

$$\text{or } \frac{81T_s + 88T_s}{88} = 1000,000$$

$$\text{or } 169 T_s = 1000,000 \times 88$$

$$\therefore T_s = \frac{1000,000 \times 88}{169} = 520710 \text{ Nmm}$$

Substituting this value in (i), we get

$$T_c + 520710 = 1000,000$$

$$\therefore T_c = 1000,000 - 520710 = 479290 \text{ Nmm}$$

Now using the relation,

$$\frac{T}{J} = \frac{\tau}{R}$$

$$\tau = \frac{T \times R}{J}$$

For a copper rod, we have

$$\tau_c = \frac{T_c \times \left(\frac{d}{2}\right)}{J_c} \quad \left(\because R = \frac{d}{2}\right)$$

$$= \frac{479290 \times \frac{30}{2}}{\frac{\pi}{32} \times 30^4} = \frac{479290 \times 15 \times 32}{\pi \times 30^4} = 90.407 \text{ N/mm}^2. \text{ Ans.}$$

And for a steel shaft, we have

$$\tau_s = \frac{T_s \times \left(\frac{D_0}{2}\right)}{J_s} = \frac{520710 \times \frac{50}{2}}{\frac{\pi}{32} \times 44 \times 10^4}$$

$$= \frac{520710 \times 25 \times 32}{\pi \times 44 \times 10^4} = 301.358 \text{ N/mm}^2. \text{ Ans.}$$

## 16.12. COMBINED BENDING AND TORSION

When a shaft is transmitting torque or power, it is subjected to shear stresses. At the same time the shaft is also subjected to bending moments due to gravity or inertia loads. Due to bending moment, bending stresses are also set up in the shaft. Hence each particle in a shaft is subjected to shear stress and bending stress. For design purposes it is necessary to find the principal stresses, maximum shear stress and strain energy. The principal stresses and maximum shear stress when a shaft is subjected to bending and torsion, are obtained as :

Consider any point on the cross-section of a shaft.

Let  $T$  = Torque at the section  
 $D$  = Diameter of the shaft  
 $M$  = B.M. at the section.

The torque  $T$  will produce shear stress at the point whereas the B.M. will produce bending stress.

Let  $q$  = Shear stress at the point produced by torque  $T$  and  
 $\sigma$  = Bending stress at the point produced by B.M. ( $M$ )

The shear stress at any point due to torque ( $T$ ) is given by

$$\frac{q}{r} = \frac{T}{J} \quad \left(\because \frac{q}{r} = \frac{\tau}{R} = \frac{T}{J}\right)$$

or 
$$q = \frac{T}{J} \times r$$

The bending stress at any point due to bending moment ( $M$ ) is given by

$$\frac{M}{I} = \frac{\sigma}{y} \quad \text{or} \quad \sigma = \frac{M \times y}{I}$$

From Art. 3.4.4, we know that the angle  $\theta$  made by the plane of maximum shear with the normal cross-section is given by,

$$\tan 2\theta = \frac{2\tau}{\sigma}$$

The bending stress and shear stress is maximum at a point on the surface of the shaft,

where  $r = R = \frac{D}{2}$  and  $y = \frac{D}{2}$

Let  $\sigma_b$  = Maximum bending stress i.e., on the surface of the shaft

$$= \frac{M}{I} \times \frac{D}{2} = \frac{M}{\frac{\pi}{64} D^4} \times \frac{D}{2} = \frac{32M}{\pi D^3}$$

$\tau$  = Maximum shear stress i.e., on the surface of the shaft

$$= \frac{T}{J} \times R = \frac{T}{\frac{\pi}{32} D^4} \times \frac{D}{2} = \frac{16T}{\pi D^3}$$

$$\therefore \tan \theta = \frac{2\tau}{\sigma} = \frac{2\tau_c}{\sigma_b} = \frac{2 \times \frac{16T}{\pi D^3}}{\frac{32M}{\pi D^3}} = \frac{T}{M} \quad \dots(16.13)$$

Major principal stress

$$= \frac{\sigma}{2} + \sqrt{\left(\frac{\sigma}{2}\right)^2 + \tau^2} = \frac{\sigma_b}{2} + \sqrt{\left(\frac{\sigma_b}{2}\right)^2 + \tau_s^2}$$

$$= \frac{32M}{2 \times \pi D^3} + \sqrt{\left(\frac{32M}{2 \times \pi D^3}\right)^2 + \left(\frac{16T}{\pi D^3}\right)^2}$$

$$= \frac{16}{\pi D^3} (M + \sqrt{M^2 + T^2}) \quad \dots(16.14)$$

and minor principal stress 
$$= \frac{16}{\pi D^3} (M - \sqrt{M^2 + T^2}) \quad \dots(16.15)$$

Maximum shear stress = 
$$\frac{\text{Major principal stress} - \text{Minor principal stress}}{2}$$

$$= \frac{16}{\pi D^3} (\sqrt{M^2 + T^2}) \quad \dots(16.16)$$

For a hollow shaft

Major principal stress 
$$= \frac{16D_0}{\pi[D_0^4 - D_i^4]} (M + \sqrt{M^2 + T^2}) \quad \dots(16.17)$$

Minor principal stress 
$$= \frac{16D_0}{\pi[D_0^4 - D_i^4]} (M - \sqrt{M^2 + T^2}) \quad \dots(16.18)$$

Maximum shear stress 
$$= \frac{16D_0}{\pi[D_0^4 - D_i^4]} (\sqrt{M^2 + T^2}) \quad \dots(16.19)$$

**Problem 16.26.** A solid shaft of diameter 80 mm is subjected to a twisting moment of 8 MN mm and a bending moment of 5 MN mm at a point. Determine :

- Principal stresses and
- Position of the plane on which they act.

**Sol. Given :**

Diameter of shaft,  $D = 80 \text{ mm}$   
 Twisting moment,  $T = 8 \text{ MN mm} = 8 \times 10^6 \text{ Nmm}$   
 Bending moment,  $M = 5 \text{ MN mm} = 5 \times 10^6 \text{ Nmm}$

The major principal stress is given by equation (16.14), as

$$\begin{aligned} \text{Major principal stress} &= \frac{16}{\pi D^3} (M + \sqrt{M^2 + T^2}) \\ &= \frac{16}{\pi \times 80^3} \left( 5 \times 10^6 + \sqrt{(5 \times 10^6)^2 + (8 \times 10^6)^2} \right) \\ &= \frac{16 \times 10^6}{\pi \times 80^3} (5 + \sqrt{25 + 64}) = 143.57 \text{ N/mm}^2. \text{ Ans.} \end{aligned}$$

Minor principal stress is given by equation (16.15).

$\therefore$  Minor principal stress

$$\begin{aligned} &= \frac{16}{\pi D^3} (M - \sqrt{M^2 + T^2}) \\ &= \frac{16}{\pi \times 80^3} \left( 5 \times 10^6 - \sqrt{(5 \times 10^6)^2 + (8 \times 10^6)^2} \right) \\ &= \frac{16 \times 10^6}{\pi \times 80^3} (5 - \sqrt{25 + 64}) = -44.1 \text{ N/mm}^2 \\ &= 44.1 \text{ N/mm}^2 \text{ (tensile)}. \text{ Ans.} \end{aligned}$$

Position of plane is given by equation (16.13), as

$$\tan 2\theta = \frac{T}{M} = \frac{8 \times 10^6}{5 \times 10^6} = 1.6$$

$$2\theta = \tan^{-1} 1.6 = 57^\circ 59.68', \text{ or } 237^\circ 59.68'$$

$$\theta = 28^\circ 59.84' \text{ or } 118^\circ 59.84'. \text{ Ans.}$$

or

**Problem 16.27.** The maximum allowable shear stress in a hollow shaft of external diameter equal to twice the internal diameter, is  $80 \text{ N/mm}^2$ . Determine the diameter of the shaft if it is subjected to a torque of  $4 \times 10^6 \text{ Nmm}$  and a bending moment of  $3 \times 10^6 \text{ Nmm}$ .

**Sol. Given :**

Maximum shear stress =  $80 \text{ N/mm}^2$   
 Torque,  $T = 4 \times 10^6 \text{ Nmm}$   
 Bending moment,  $M = 3 \times 10^6 \text{ Nmm}$

Let  $D_0$  = External diameter of shaft  
 $D_i$  = Internal diameter of shaft

Then  $D_0 = 2D_i$

Using equation (16.19) for a hollow shaft, we get

$$\begin{aligned} \text{Maximum shear stress} &= \frac{16D_0}{\pi(D_0^4 - D_i^4)} (\sqrt{M^2 + T^2}) \\ 80 &= \frac{16D_0}{\pi \left[ D_0^4 - \left( \frac{D_0}{2} \right)^4 \right]} \left[ \sqrt{(3 \times 10^6)^2 + (4 \times 10^6)^2} \right] \end{aligned}$$

or

$$= \frac{16D_0 \times 10^6 [\sqrt{9 + 16}]}{\pi D_0^4 \left[ 1 - \frac{1}{16} \right]} = \frac{16 \times 10^6 \times 5}{\pi D_0^3 \times \frac{15}{16}}$$

$$D_0^3 = \frac{16 \times 10^6 \times 5 \times 16}{\pi \times 15 \times 80} = 0.3395 \times 10^6$$

$$D_0 = (0.3395 \times 10^6)^{1/3} = 0.3395^{1/3} \times 10^2 = 69.78 \text{ mm. Ans.}$$

and

$$D_i = \frac{D_0}{2} = \frac{69.78}{2} = 34.89 \text{ mm. Ans.}$$

### 16.13. EXPRESSION FOR STRAIN ENERGY STORED IN A BODY DUE TO TORSION

Consider a solid shaft which is in torsion. Take an elementary ring of width  $dr$  at a radius  $r$  as shown in Fig. 16.10.

Let  $D$  = Diameter of shaft

$l$  = Length of shaft

$R$  = Radius of shaft =  $\frac{D}{2}$

$\tau$  = Shear stress on the surface of the shaft i.e., at radius  $R$

$C$  = Shear modulus or modulus of rigidity

$U$  = Total shear strain energy in the shaft.

Then shear stress due to torsion at a radius  $r$  from the centre is given by

$$\frac{\tau_r}{r} = \frac{\tau}{R} \text{ or } \tau_r = \frac{r}{R} \times \tau$$

Area of elementary ring,  $dA = 2\pi r \cdot dr$

$\therefore$  Volume of ring,  $V = dA \cdot l = 2\pi r \times dr \times l$

The shear strain energy is given by equation (16.9) as,

$$\text{Shear strain energy} = \frac{(\text{Shear stress})^2}{2C} \times \text{Volume}$$

$\therefore$  Shear strain energy in the ring of radius  $r$

$$= \frac{\left( \frac{r}{R} \times \tau \right)^2}{2C} \times 2\pi r \cdot dr \cdot l = \frac{\tau^2 \cdot l}{2CR^2} \times r^2 \times 2\pi r \cdot dr$$

Total shear strain energy stored in the shaft is obtained by integrating the above equation between limits 0 to  $R$ .

$\therefore$  Total strain energy stored in the shaft,

$$\begin{aligned} U &= \int_0^R \frac{\tau^2 \cdot l}{2CR^2} \cdot r^2 \cdot 2\pi r \cdot dr = \frac{\tau^2 \cdot l}{2CR^2} \int_0^R r^2 \cdot 2\pi r \cdot dr \\ &= \frac{\tau^2 \cdot l}{2CR^2} \int_0^R r^2 \cdot dA. \end{aligned} \quad (\because dA = 2\pi \cdot dr)$$

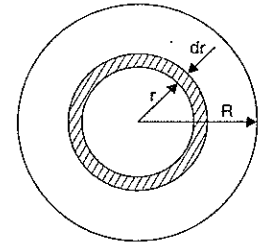

Fig. 16.10

$$= \frac{\tau^2 \cdot l}{2CR^2} J \quad \left[ \because \int_0^R r^2 \cdot dA = J \right] \quad \dots(i)$$

where  $J$  = Polar moment of inertia of the shaft

$$= \frac{\pi}{32} \times D^4 \text{ for a solid shaft.}$$

$\therefore$  Total strain energy in the shaft due to torsion,

$$\begin{aligned} U &= \frac{\tau^2 \cdot l}{2CR^2} \times \frac{\pi}{32} D^4 \\ &= \frac{\tau^2 \cdot l}{2CR^2} \times \frac{\pi}{32} \times (2R)^4 \quad (\because D = 2R) \\ &= \frac{\tau^2 \cdot l}{2CR^2} \times \frac{\pi}{32} \times 16R^4 = \frac{\tau^2}{4C} \cdot \pi R^2 \cdot l \\ &= \frac{\tau^2}{4C} \cdot V \quad (\because \text{Volume, } V = \pi R^2 \cdot l) \quad \dots(16.20) \end{aligned}$$

**Total strain energy in the hollow shaft due to torsion**

Let  $D$  = Outer dia. of shaft

$d$  = Inner dia. of shaft

$J$  = Polar moment of inertia of hollow shaft

$$= \frac{\pi}{32} [D^4 - d^4]$$

Substituting the value of  $J$  in equation (i), we get

Total strain energy in the hollow shaft due to torsion,

$$\begin{aligned} U &= \frac{\tau^2 \cdot l}{2CR^2} \times \frac{\pi}{32} [D^4 - d^4] \\ &= \frac{\tau^2 \cdot l}{2C \left(\frac{D}{2}\right)^2} \times \frac{\pi}{32} [D^4 - d^4] \quad \left[ \because R = \frac{D}{2} \right] \\ &= \frac{\tau^2 \cdot l \times 4}{2C \cdot D^2} \times \frac{\pi}{32} [D^4 - d^4] \\ &= \frac{\tau^2}{4CD^2} \times \frac{\pi}{4} \times (D^4 - d^4) \cdot l \\ &= \frac{\tau^2}{4CD^2} \times V \times (D^2 + d^2) \quad \left[ \because V = \frac{\pi}{4} (D^2 - d^2) \cdot l \right] \\ &= \frac{\tau^2}{4CD^2} (D^2 + d^2) \times V \quad \dots(16.21) \end{aligned}$$

**Problem 16.28.** Determine the maximum strain energy stored in a solid shaft of diameter 10 cm and of length 1.25 m, if the maximum allowable shear stress is 50 N/mm<sup>2</sup>. Take  $C = 8 \times 10^4$  N/mm<sup>2</sup>.

**Sol. Given :**

Dia. of shaft,  $D = 10$  cm

$$\therefore \text{Area of shaft, } A = \frac{\pi}{4} \times 10^2 = 78.54 \text{ cm}^2 = 7854 \text{ mm}^2$$

Length of shaft,  $l = 1.25 \text{ m} = 125 \text{ cm}$

$$\therefore \text{Volume of shaft, } V = A \times l = 78.54 \times 125 = 9817.5 \text{ cm}^3 = 9817.5 \times 10^3 \text{ mm}^3$$

Maximum allowable shear stress,

$$\tau = 50 \text{ N/mm}^2$$

(shear stress is maximum on the surface of the shaft)

Modulus of rigidity,  $C = 8 \times 10^4$  N/mm<sup>2</sup>

Let  $U$  = Shear strain energy stored in the shaft.

Using equation (16.20), we get

$$\begin{aligned} U &= \frac{\tau^2}{4C} \times V = \frac{50^2}{4 \times 8 \times 10^4} \times 9817.5 \times 10^3 \\ &= 76699 \text{ Nmm. Ans.} \end{aligned}$$

**Problem 16.29.** The external and internal diameters of a hollow shaft are 40 cm and 20 cm. Determine the maximum strain energy stored in the hollow shaft if the maximum allowable shear stress is 50 N/mm<sup>2</sup> and length of the shaft is 5 m. Take  $C = 8 \times 10^4$  N/mm<sup>2</sup>.

**Sol. Given :**

External dia.,  $D = 40 \text{ cm} = 400 \text{ mm}$

Internal dia.,  $d = 20 \text{ cm} = 200 \text{ mm}$

$$\therefore \text{Area of cross-section, } A = \frac{\pi}{4} (40^2 - 20^2) = 942.47 \text{ cm}^2 = 94247 \text{ mm}^2$$

Maximum allowable shear stress (i.e., shear stress on the surface of the shaft),

$$\tau = 50 \text{ N/mm}^2$$

Length of shaft,  $l = 5 \text{ m} = 500 \text{ cm}$

$\therefore$  Volume of hollow shaft,

$$V = A \times l = 942.47 \times 500 = 471235 \text{ cm}^3 = 471235 \times 10^3 \text{ mm}^3$$

Modulus of rigidity,  $C = 8 \times 10^4$  N/mm<sup>2</sup>

Let  $U$  = Strain energy stored

Using equation (16.21), we have

$$\begin{aligned} U &= \frac{\tau^2}{4CD^2} (D^2 + d^2) \times V \\ &= \frac{50^2}{4 \times 8 \times 10^4 \times 400^2} \times (400^2 + 200^2) \times 471235 \times 10^3 \\ &= 4601900 \text{ Nmm} = 4601.9 \text{ Nm. Ans.} \end{aligned}$$

**Problem 16.30.** Calculate the diameters of a hollow shaft of the same length and same cross-sectional area as a solid shaft of 15 cm diameter if the strain energy in the hollow shaft is 25% greater than that of solid shaft transmitting the same torque at the same maximum shear stress.

**Sol. Given :**

Dia. of solid shaft,  $D = 15 \text{ cm}$

$$\therefore \text{Area of solid shaft, } A = \frac{\pi}{4} \times 15^2 = 56.25 \pi \text{ cm}^2$$

Area of solid shaft = Area of hollow shaft

Length of solid shaft = Length of hollow shaft

$\therefore$  Volume of solid shaft = Volume of hollow shaft

Strain energy in solid shaft = 1.25 of strain energy in solid shaft

Maximum shear stress in solid shaft

= Maximum shear stress in hollow shaft

Let  $D_1$  = External dia. of hollow shaft

$D_2$  = Internal dia. of hollow shaft

∴ Cross-sectional area of hollow shaft

$$= \frac{\pi}{4} [D_1^2 - D_2^2]$$

But cross-sectional area of hollow shaft

= Area of solid shaft (given)

$$\therefore \frac{\pi}{4} (D_1^2 - D_2^2) = 56.25\pi$$

$$\therefore D_1^2 - D_2^2 = 56.25 \times 4 = 225 \quad \dots(i)$$

Let  $\tau$  = Max. shear stress in solid as well as in hollow shafts,

$U_s$  = Strain energy of solid shaft, and

$U_h$  = Strain energy of hollow shaft.

Using equation (16.20) for the strain energy in solid shaft, we get

$$U_s = \frac{\tau^2}{4C} \times \text{Volume of solid shaft.}$$

Using equation (16.21) for the strain energy in hollow shaft,

$$U_h = \frac{\tau^2}{4CD_1^2} (D_1^2 - D_2^2) \times \text{Volume of hollow shaft}$$

(∵ External dia. =  $D_1$ , Internal dia. =  $D_2$ )

But  $U_h = 1.25 \times U_s$

$$\frac{\tau^2}{4CD_1^2} (D_1^2 + D_2^2) \times \text{Volume of hollow shaft}$$

$$= 1.25 \times \frac{\tau^2}{4C} \times \text{Volume of solid shaft}$$

$$\frac{\tau^2}{4CD_1^2} (D_1^2 + D_2^2) = 1.25 \frac{\tau^2}{4C}$$

(∵ Volume of hollow shaft = Volume of solid shaft)

$$\frac{D_1^2 + D_2^2}{D_1^2} = 1.25 \quad \left( \text{Cancelling } \frac{\tau^2}{4C} \text{ to both sides} \right)$$

$$D_1^2 + D_2^2 = 1.25 D_1^2$$

$$D_2^2 = 1.25 D_1^2 - D_1^2 = 0.25 D_1^2$$

$$\therefore D_2 = \sqrt{0.25 D_1^2} = 0.5 D_1 \quad \dots(ii)$$

Substituting this value of  $D_2$  in equation (i), we get

$$D_1^2 - 0.25 D_1^2 = 225 \quad \text{or} \quad 0.75 D_1^2 = 225$$

$$\therefore D_1^2 = \frac{225}{0.75} = 300$$

$$\therefore D_1 = \sqrt{300} = 17.32 \text{ cm. Ans.}$$

Substituting this value of  $D_1$  in equation (ii), we get

$$D_2 = 0.5 \times 17.32 = 8.66 \text{ cm. Ans.}$$

**Problem 16.31.** A solid circular shaft of 10 cm diameter of length 4 m is transmitting 112.5 kW power at 150 r.p.m. Determine : (i) the maximum shear stress induced in the shaft and (ii) Strain energy stored in the shaft. Take  $C = 8 \times 10^4 \text{ N/mm}^2$ .

**Sol.** Given :

Dia. of shaft,  $D = 10 \text{ cm} = 100 \text{ mm}$

Length of shaft,  $l = 4 \text{ m} = 4000 \text{ mm}$

Power,  $P = 112.5 \text{ kW} = 112.5 \times 10^3 \text{ W}$

Speed of shaft,  $N = 150 \text{ r.p.m.}$

Modulus of rigidity,  $C = 8 \times 10^4 \text{ N/mm}^2$

Let  $\tau$  = Maximum shear stress induced in the shaft and

$U$  = Strain energy stored in the shaft.

$$\text{We know} \quad P = \frac{2\pi NT}{60}$$

$$\text{or} \quad 112.5 \times 10^3 = \frac{2\pi \times 150 \times T}{60}$$

$$\therefore T = \frac{112.5 \times 10^3 \times 60}{2\pi \times 150} = 7159 \text{ Nm} = 7159000 \text{ Nmm}$$

$$\text{But we know,} \quad T^* = \frac{\pi}{16} \times \tau \times D^3$$

$$\text{or} \quad 7159000 = \frac{\pi}{16} \times \tau \times 100^3$$

$$\therefore \tau = \frac{7159000 \times 16}{\pi \times 10^6} = 36.5 \text{ N/mm}^2$$

Using equation (16.20) for strain energy,

$$U = \frac{\tau^2}{4C} \times \text{Volume of shaft}$$

$$= \frac{36.5^2}{4 \times 8 \times 10^4} \times \text{Volume of shaft}$$

$$= \frac{36.5^2}{4 \times 8 \times 10^4} \times \frac{\pi}{4} \times 100^2 \times 4000 \quad \left( \because \text{Volume} = \frac{\pi}{4} \times D^2 \times l \right)$$

$$= 130793 \text{ Nmm. Ans.}$$

**Problem 16.32.** A hollow shaft of internal diameter 10 cm, is subjected to pure torque and attains a maximum shear stress  $q$  on the outer surface of the shaft. If the strain energy stored in the hollow shaft is given by  $\frac{\tau^2}{3C} \times V$ , determine the external diameter of the shaft.

**Sol.** Given :

Internal dia.,  $d = 10 \text{ cm}$

Maximum shear stress =  $\tau$

\*Please see equation 16.4 on page 675. Here  $q = \tau$ .

Strain energy stored,  $U = \frac{\tau^2}{3C} \times V$  where  $V = \text{Volume}$

Let  $D = \text{External diameter of the hollow shaft.}$

Using equation (16.21) for the strain energy in hollow shaft

$$U = \frac{\tau^2}{4CD^2} (D^2 + d^2) \times V$$

Equating the two values of strain energy, we get

$$\frac{\tau^2}{4CD^2} (D^2 + d^2) \times V = \frac{\tau^2}{3C} \times V$$

$$\text{or } \frac{D^2 + d^2}{4D^2} = \frac{1}{3} \quad \left( \text{Cancelling } \frac{\tau^2}{C} \times V \text{ to both sides} \right)$$

$$\text{or } 3D^2 + 3d^2 = 4D^2$$

$$\text{or } 3d^2 = 4D^2 - 3D^2 = D^2$$

$$\text{or } \frac{D^2}{d^2} = 3 \quad \text{or} \quad \frac{D}{d} = \sqrt{3} = 1.732$$

$$\therefore D = 1.732 \times d = 1.732 \times 10 = 17.32 \text{ cm. Ans.}$$

**16.13.1. Torsion of tapering shafts.** Fig. 16.10 (a) shows a shaft which tapers uniformly from radius  $R_1$  to radius  $R_2$  and the shaft is subjected to a twisting moment  $T$ . Due to the twisting moment, the shear stress will be developed in the shaft. The shear stress is directly proportional to radius. Hence shear stress will be different at the surface of the two ends of the shaft (as the two ends are having different radius).

Let  $\tau_1 = \text{Shear stress on the surface of the shaft at left end where radius is } R_1$

$\tau_2 = \text{Shear stress on the surface of the shaft at right end where radius is } R_2$

$\tau_x = \text{Shear stress on the surface of the shaft which is at a distance of } x \text{ from the left end}$

$L = \text{Length of the shaft}$

$D_1 = \text{Dia. of shaft at left end} = 2R_1$

$D_2 = \text{Dia. of shaft at right end} = 2R_2$

$D_x = \text{Dia. of shaft at a distance } x \text{ from the left end} = 2R_x \text{ where } R_x \text{ is the radius at that section.}$

The radius  $R_x$  at a distance  $x$  from left end is given by,

$$R_x = R_1 + \left( \frac{R_2 - R_1}{L} \right) \times x$$

or diameter  $D_x$  at a distance  $x$  from left end is given by

$$D_x = D_1 + \left( \frac{D_2 - D_1}{L} \right) \times x \quad \dots(i)$$

We know that,  $T = \tau \times \frac{\pi}{16} D^3.$

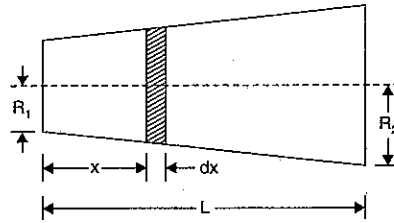

Fig. 16.10 (a)

The shaft is subjected to a constant torque  $T$ .

$$\therefore T = \tau_1 \times \frac{\pi}{16} D_1^3 = \tau_2 \times \frac{\pi}{16} D_2^3 = \tau_x \times \frac{\pi}{16} D_x^3$$

$$\text{or } \tau_1 \times D_1^3 = \tau_2 \times D_2^3 = \tau_x \times D_x^3 \quad \dots(ii)$$

Let us find the total angle of twist for this tapering shaft of length 'L'.

Consider a small length  $dx$  of this shaft.

Let  $d\theta = \text{Angle of twist of small length } dx$

$\theta = \text{Total angle of twist of total length } L'$

$$\text{Using equation, } \frac{T}{J} = \frac{C\theta}{L}$$

For a small length  $dx$ , the angle of twist is  $d\theta$ . Hence the above equation becomes as

$$\frac{T}{J} = \frac{C \times d\theta}{dx}$$

where  $J = \text{Polar moment of inertia corresponding to diameter } D_x$

$$= \frac{\pi}{32} D_x^4$$

$$\text{or } d\theta = \frac{T \times dx}{J \times C} = \frac{T \times dx}{\frac{\pi}{32} D_x^4 \times C} = \frac{32T \times dx}{\pi C \times D_x^4}$$

$$\text{or } d\theta = \frac{32T \, dx}{\pi \times C \times \left[ D_1 + \frac{D_2 - D_1}{L} \times x \right]^4}$$

[  $\because D_x = D_1 + \frac{D_2 - D_1}{L} \times x$  from equation (i) ]

$$\text{Let } \frac{D_2 - D_1}{L} = k \text{ (some constant)}$$

$$\text{Then } d\theta = \frac{32T \, dx}{\pi \times C \times [D_1 + kx]^4}$$

The total angle of twist for the total length of the shaft is obtained by integrating the above equation as given by

$$\begin{aligned} \theta &= \int d\theta \\ &= \int_0^L \frac{32T \, dx}{\pi \times C \times [D_1 + kx]^4} \quad (\because x \text{ varies from } 0 \text{ to } L) \\ &= \frac{32T}{\pi \times C} \int_0^L \frac{dx}{[D_1 + kx]^4} \quad (\because T \text{ is constant}) \\ &= \frac{32T}{\pi \times C} \int_0^L [D_1 + kx]^{-4} dx = \frac{32T}{\pi \times C} \left[ \frac{(D_1 + kx)^{-3}}{(-3) \times k} \right]_0^L \\ &= (-) \frac{32T}{\pi \times C} \times \frac{1}{3k} \left[ (D_1 + kx)^{-3} \right]_0^L \\ &= (-) \frac{32T}{\pi \times C} \times \frac{1}{3k} \left[ (D_1 + kL)^{-3} - (D_1)^{-3} \right] \end{aligned}$$

$$= (-) \frac{32T}{\pi \times C} \times \frac{1}{3k} \left[ \frac{1}{(D_1 + kL)^3} - \frac{1}{D_1^3} \right]$$

As  $\frac{D_2 - D_1}{L} = k$  hence  $D_2 = Lk + D_1$  or  $D_2 = D_1 + kL$

Now above equation becomes as

$$\theta = (-) \frac{32T}{\pi C} \times \frac{1}{3k} \left[ \frac{1}{D_2^3} - \frac{1}{D_1^3} \right]$$

$$= \frac{32T}{\pi C} \times \frac{1}{3k} \left[ \frac{1}{D_1^3} - \frac{1}{D_2^3} \right] \quad \dots[16.21(A)]$$

**Problem 16.32(A).** Determine the angle of twist and maximum shear stress developed in a shaft which tapers uniformly from a diameter of 160 mm to a diameter of 240 mm. The length of shaft is 2 m and transmits a torque of 48 kNm. Take the value of modulus of rigidity for shaft material as = 80 GN/m<sup>2</sup>.

**Sol.** Given :

$D_1 = 160 \text{ mm} = 0.16 \text{ m}$  ;  $D_2 = 240 \text{ mm} = 0.24 \text{ m}$ ,  $L = 2 \text{ m}$ ,  $T = 48 \text{ kNm} = 48 \times 10^3 \text{ Nm}$ , and  $C = 80 \text{ GN/m}^2 = 80 \times 10^9 \text{ N/m}^2$

Find : (i) Angle of twist  $\theta$  and

(ii) Maximum shear stress developed.

(i) **Angle of twist,  $\theta$**

The angle of twist,  $\theta$  is given by equation 16.21(A), as

$$\theta = \frac{32T}{\pi C} \times \frac{1}{3k} \left[ \frac{1}{D_1^3} - \frac{1}{D_2^3} \right]$$

where  $k = \frac{D_2 - D_1}{L}$

$$= \frac{0.240 - 0.160}{2} = \frac{0.08}{2} = 0.04$$

$$\therefore \theta = \frac{32 \times 48 \times 10^3}{\pi \times 80 \times 10^9} \times \frac{1}{3 \times 0.04} \left[ \frac{1}{0.16^3} - \frac{1}{0.24^3} \right]$$

$$[\because T = 48 \times 10^3 \text{ Nm and } C = 80 \times 10^9 \text{ N/m}^2]$$

$$= 0.00005093 [244.14 - 72.34]$$

$$= 0.00875 \text{ radians} = .00875 \times \frac{180}{\pi} = \mathbf{0.501. \text{ Ans.}}$$

(ii) **Maximum shear stress developed**

We know  $T = \tau \times \frac{\pi}{16} \times D^3$

For a given torque, the shear stress on the surface of the shaft will be maximum where diameter is minimum. Hence at smaller diameter, the shear stress will be maximum.

$$\therefore T = \tau_{\max} \times \frac{\pi}{16} \times D_1^3 \quad \text{where } D_1 = \text{smaller diameter} = 0.160 \text{ m}$$

or  $48 \times 10^3 = \tau_{\max} \times \frac{\pi}{16} \times 0.16^3$

or  $\tau_{\max} = \frac{48 \times 10^3 \times 16}{\pi \times 0.16^3} = 59683103 \text{ N/m}^2 = \mathbf{59.683103 \text{ MN/m}^2. \text{ Ans.}}$

## 16.14. SPRINGS

Springs are the elastic bodies which absorb energy due to resilience. The absorbed energy may be released as and when required. A spring which is capable of absorbing the greatest amount of energy for the given stress, without getting permanently distorted, is known as the best spring. The two important types of springs are :

1. Laminated or leaf springs and
2. Helical springs.

**16.14.1. Laminated or leaf spring.** The laminated springs are used to absorb shocks in railway wagons, coaches and road vehicles (such as cars, lorries etc.).

Fig. 16.11 shows a laminated spring which consists of a number of parallel strips of a metal having different lengths and same width, placed one over the other. Initially all the plates are bent to the same radius and are free to slide one over the other. Fig. 16.11 shows the initial position of the spring, which is having some central deflection  $\delta$ . The spring rests on the axis of the vehicle and its top plate is pinned at the ends to the chassis of the vehicle.

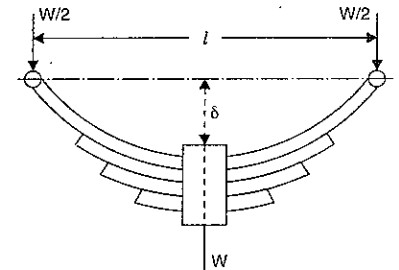

Fig. 16.11

When the spring is loaded to the designed load  $W$ , all the plates become flat and the central deflection ( $\delta$ ) disappears.

Let  $b$  = Width of each plate

$n$  = Number of plates

$l$  = Span of spring

$\sigma$  = Maximum bending stress developed in the plates

$t$  = Thickness of each plates

$W$  = Point load acting at the centre of the spring and

$\delta$  = Original deflection of the top spring.

**Expression for maximum bending stress developed in the plate.** The load  $W$  acting at the centre of the lowermost plate, will be shared equally on the two ends of the top plate as shown in Fig. 16.11.

$$\therefore \text{B.M. at the centre} = \text{Load at one end} \times \frac{l}{2}$$

or  $M = \frac{W}{2} \times \frac{l}{2} = \frac{W \cdot l}{4} \quad \dots(i)$

The moment of inertia of each plate,

$$I = \frac{bt^3}{12}$$



But the relation among bending stress ( $\sigma$ ), bending moment ( $M$ ) and moment of inertia ( $I$ ) is given by

$$\frac{M}{I} = \frac{\sigma}{y} \quad \left( \text{Here } y = \frac{t}{2} \right)$$

or

$$M = \frac{\sigma}{y} \times I = \frac{\sigma \times \frac{bt^3}{12}}{\frac{t}{2}} = \frac{\sigma \cdot bt^2}{6}$$

$\therefore$  Total resisting moment by  $n$  plates

$$= n \times M = \frac{n \times \sigma \cdot bt^2}{6} \quad \dots(ii)$$

As the maximum B.M. due to load is equal to the total resisting moment, therefore equating (i) and (ii),

$$\frac{W \cdot l}{4} = \frac{n \sigma \cdot bt^2}{6}$$

$$\therefore \sigma = \frac{6W \cdot l}{4 \cdot n \cdot b \cdot t^2} = \frac{3Wl}{2nbt^2} \quad \dots(16.22)$$

Equation (16.22) gives the maximum stress developed in the plate of the spring.

#### Expression for central deflection of the leaf spring

Now  $R$  = Radius of the plate to which they are

bent.

From triangle  $ACO$  of Fig. 16.12, we have

$$AO^2 = AC^2 + CO^2$$

or

$$R^2 = \left( \frac{l}{2} \right)^2 + (R - \delta)^2$$

$$= \frac{l^2}{4} + R^2 + \delta^2 - 2R\delta$$

$$= \frac{l^2}{4} + R^2 - 2R\delta \quad (\text{Neglecting } \delta^2 \text{ which is a small quantity})$$

$$\therefore 2R\delta = \frac{l^2}{4}$$

$$\therefore \delta = \frac{l^2}{4 \times 2R} = \frac{l^2}{8R} \quad \dots(iii)$$

But the relation between bending stress, modulus of elasticity and radius of curvature ( $R$ ) is given by

$$\frac{\sigma}{y} = \frac{E}{R}$$

$$R = \frac{E \times y}{\sigma} = \frac{E \times t}{2\sigma} \quad \left( \text{Here } y = \frac{t}{2} \right)$$

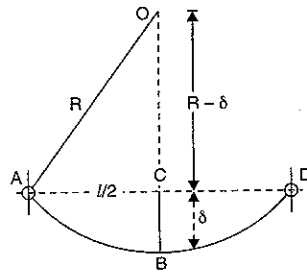

Fig. 16.12

Substituting this value of  $R$  in equation (iii), we get

$$\delta = \frac{l^2 \times 2\sigma}{8 \times E \times t} = \frac{\sigma \cdot l^2}{4Et} \quad \dots(16.23)$$

Equation (16.23) gives the central deflection of the spring.

**Problem 16.33.** A leaf spring carries a central load of 3000 N. The leaf spring is to be made of 10 steel plates 5 cm wide and 6 mm thick. If the bending stress is limited to 150 N/mm<sup>2</sup> determine :

(i) Length of the spring and

(ii) Deflection at the centre of the spring.

Take  $E = 2 \times 10^5$  N/mm<sup>2</sup>.

**Sol.** Given :

Central load,  $W = 3000$  N

No. of plates,  $n = 10$

Width of each plates,  $b = 5$  cm = 50 mm

Thickness,  $t = 6$  mm

Bending stress,  $\sigma = 150$  N/mm<sup>2</sup>

Modulus of elasticity,  $E = 2 \times 10^5$  N/mm<sup>2</sup>.

Let  $l$  = Length of spring

$\delta$  = Deflection at the centre of spring.

Using equation (16.22),

$$\sigma = \frac{3Wl}{2nbt^2}$$

or

$$150 = \frac{3 \times 3000 \times l}{2 \times 10 \times 50 \times 6^2}$$

$\therefore$

$$l = \frac{150 \times 2 \times 10 \times 50 \times 6^2}{3 \times 3000} = 600 \text{ mm. Ans.}$$

Using equation (16.23) for deflection,

$$\delta = \frac{\sigma \cdot l^2}{4Et} = \frac{150 \times 600^2}{4 \times 2 \times 10^5 \times 6} = 11.25 \text{ mm. Ans.}$$

**Problem 16.34.** A laminated spring 1 m long is made up of plates each 5 cm wide and 1 cm thick. If the bending stress in the plate is limited to 100 N/mm<sup>2</sup>, how many plates would be required to enable the spring to carry a central point load of 2 kN? If  $E = 2.1 \times 10^5$  N/mm<sup>2</sup>, what is the deflection under the load? (AMIE, Summer 1982)

**Sol.** Given :

Length of spring,  $l = 1$  m = 1000 mm

Width of each plate,  $b = 5$  cm = 50 mm

Thickness of each plate,  $t = 1$  cm = 10 mm

Bending stress,  $\sigma = 100$  N/mm<sup>2</sup>

Central load on spring,  $W = 2$  kN = 2000 N

Young's modulus,  $E = 2.1 \times 10^5$  N/mm<sup>2</sup>

Let  $n$  = Number of plates and

$\delta$  = Deflection under the load.

Using the equation (16.22),

$$\sigma = \frac{3Wl}{2\pi b t^2} \quad \text{or} \quad 100 = \frac{3 \times 2000 \times 1000}{2 \times n \times 50 \times 10^2}$$

$$n = \frac{3 \times 2000 \times 1000}{100 \times 2 \times 50 \times 100} = 6. \quad \text{Ans.}$$

Deflection under load

Using equation (16.23),

$$\delta = \frac{\sigma \times l^2}{4E \times t} = \frac{100 \times 1000^2}{4 \times 2.1 \times 10^5 \times 10} = 11.9 \text{ mm. Ans.}$$

**16.14.2. Helical Springs.** Helical springs are the thick spring wires coiled into a helix.

They are of two types :

1. Close-coiled helical springs and
2. Open coiled helical springs.

**Close-coiled helical springs.** Close-coiled helical springs are the springs in which helix angle is very small or in other words the pitch between two adjacent turns is small. A close-coiled helical spring carrying an axial load is shown in Fig. 16.13. As the helix angle in case of close-coiled helical springs are small, hence the bending effect on the spring is ignored and we assume that the coils of a close-coiled helical springs are to stand purely torsional stresses.

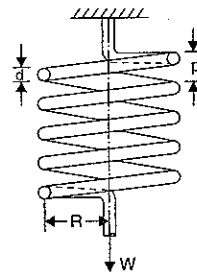

Fig. 16.13

**Expression for max. shear stress induced in wire.**

Fig. 16.13 shows a close-coiled helical spring subjected to an axial load.

- Let
- $d$  = Diameter of spring wire
  - $p$  = Pitch of the helical spring
  - $n$  = Number of coils
  - $R$  = Mean radius of spring coil
  - $W$  = Axial load on spring
  - $C$  = Modulus of rigidity
  - $\tau$  = Max. shear stress induced in the wire
  - $\theta$  = Angle of twist in spring wire, and
  - $\delta$  = Deflection of spring due to axial load
  - $l$  = Length of wire.

Now twisting moment on the wire,

$$T = W \times R \quad \dots(i)$$

But twisting moment is also given by

$$T = \frac{\pi}{16} \tau d^3 \quad \dots(ii)$$

Equating equations (i) and (ii), we get

$$W \times R = \frac{\pi}{16} \tau d^3 \quad \text{or} \quad \tau = \frac{16W \times R}{\pi d^3} \quad \dots(16.24)$$

Equation (16.24) gives the max. shear stress induced in the wire.

**Expression for deflection of spring**

Now length of one coil =  $\pi D$  or  $2\pi R$

$\therefore$  Total length of the wire = Length of one coil  $\times$  No. of coils or  $l = 2\pi R \times n$ .

As the every section of the wire is subjected to torsion, hence the strain energy stored by the spring due to torsion is given by equation (16.20).

$\therefore$  Strain energy stored by the spring,

$$\begin{aligned} U &= \frac{\tau^2}{4C} \cdot \text{Volume} = \frac{\tau^2}{4C} \cdot \text{Volume} \\ &= \left( \frac{16W \cdot R}{\pi d^3} \right)^2 \times \frac{1}{4C} \times \left( \frac{\pi}{4} d^2 \times 2\pi R \cdot n \right) \\ &\quad \left( \because \tau = \frac{16WR}{\pi d^3} \text{ and Volume} = \frac{\pi}{4} d^2 \times \text{Total length of wire} \right) \\ &= \frac{32W^2 R^2}{Cd^4} \cdot R \cdot n = \frac{32W^2 R^3 \cdot n}{Cd^4} \quad \dots(16.25) \end{aligned}$$

Work done on the spring = Average load  $\times$  Deflection

$$= \frac{1}{2} W \times \delta \quad (\because \text{Deflection} = \delta)$$

Equating the work done on spring to the energy stored, we get

$$\begin{aligned} \frac{1}{2} W \cdot \delta &= \frac{32W^2 R^3 \cdot n}{Cd^4} \\ \therefore \delta &= \frac{64WR^3 n}{Cd^4} \quad \dots(16.26) \end{aligned}$$

**Expression for stiffness of spring**

The stiffness of spring,

$$\begin{aligned} s &= \text{Load per unit deflection} \\ &= \frac{W}{\delta} = \frac{W}{\frac{64 \cdot WR^3 \cdot n}{Cd^4}} = \frac{Cd^4}{64 \cdot R^3 \cdot n} \quad \dots(16.27) \end{aligned}$$

**Note.** The solid length of the spring means the distance between the coils when the coils are touching each other. There is no gap between the coils. The solid length is given by

$$\text{Solid length} = \text{Number of coils} \times \text{Dia. of wire} = n \times d \quad \dots(16.28)$$

**Problem 16.35.** A closely coiled helical spring is to carry a load of 500 N. Its mean coil diameter is to be 10 times that of the wire diameter. Calculate these diameters if the maximum shear stress in the material of the spring is to be 80 N/mm<sup>2</sup>.

(AMIE, Summer 1985)

**Sol. Given :**

Load on spring,  $W = 500 \text{ N}$

Max. shear stress,  $\tau = 80 \text{ N/mm}^2$

Let  $d$  = Diameter of wire

$D$  = Mean diameter of coil

$D = 10 d$ .

Using equation (16.24),  $\tau = \frac{16WR}{\pi d^3}$

$$\text{or } 80 = \frac{16 \times 500 \times \left(\frac{D}{2}\right)}{\pi d^3} \quad \left(\because R = \frac{D}{2}\right)$$

$$= \frac{8000 \times \left(\frac{10d}{2}\right)}{\pi d^3} \quad (\because D = 10d)$$

$$\text{or } 80 \times \pi d^3 = 8000 \times 5d$$

$$\text{or } d^2 = \frac{8000 \times 5}{80 \times \pi} = 159.25$$

$$\therefore d = \sqrt{159.15} = 12.6 \text{ mm} = 1.26 \text{ cm. Ans.}$$

$$\therefore D = 10 \times d = 10 \times 1.26 = 12.6 \text{ cm. Ans.}$$

**Problem 16.36.** In problem 16.35, if the stiffness of the spring is 20 N per mm deflection and modulus of rigidity =  $8.6 \times 10^4 \text{ N/mm}^2$ , find the number of coils in the closely coiled helical spring.

**Sol. Given :**

$$\text{Stiffness, } s = 20 \text{ N/mm}$$

$$\text{Modulus of rigidity, } C = 8.4 \times 10^4 \text{ N/mm}^2$$

From problem 16.35,

$$W = 500 \text{ N, } \tau = 80 \text{ N/mm}^2$$

$$d = 12.6 \text{ mm and } D = 126 \text{ mm}$$

$$\therefore R = D/2 = 126/2 = 63 \text{ mm}$$

Let  $n =$  Number of coils in the spring

$$\text{We know, stiffness} = \frac{\text{Load}}{\delta}$$

$$\text{or } 20 = \frac{500}{\delta}$$

$$\therefore \delta = \frac{500}{20} = 25 \text{ mm}$$

Using equation (16.26),

$$\delta = \frac{64WR^3 \cdot n}{C \cdot d^4}$$

$$\text{or } 25 = \frac{64 \times 500 \times (63)^3 \times n}{8.4 \times 10^4 \times 12.6^4} \quad (\because R = 63 \text{ mm})$$

$$\therefore n = \frac{25 \times 8.4 \times 10^4 \times 12.6^4}{64 \times 500 \times (63)^3} = 6.6 \text{ say } 7.0$$

$$\text{or } n = 7. \text{ Ans.}$$

**Problem 16.37.** A closely coiled helical spring of round steel wire 10 mm in diameter having 10 complete turns with a mean diameter of 12 cm is subjected to an axial load of 200 N. Determine : (i) the deflection of the spring (ii) maximum shear stress in the wire, (iii) stiffness of the spring. Take  $C = 8 \times 10^4 \text{ N/mm}^2$ .

**Sol. Given :**

$$\text{Dia. of wire, } d = 10 \text{ mm}$$

$$\text{No. of turns, } n = 10$$

$$\text{Mean dia. of coil, } D = 12 \text{ cm} = 120 \text{ mm}$$

$$\therefore \text{Radius of coil, } R = D/2 = 60 \text{ mm}$$

$$\text{Axial load, } W = 200 \text{ N}$$

$$\text{Modulus of rigidity, } C = 8 \times 10^4 \text{ N/mm}^2$$

$$\text{Let } \delta = \text{Deflection of the spring}$$

$$\tau = \text{Max. shear stress in the wire}$$

$$s = \text{Stiffness of the spring.}$$

(i) Using equation (16.26),

$$\delta = \frac{64WR^3 \times n}{Cd^4} = \frac{64 \times 200 \times 60^3 \times 10}{8 \times 10^4 \times 10^4} = 34.5 \text{ mm. Ans.}$$

(ii) Using equation (16.24),

$$\tau = \frac{16WR}{\pi d^3} = \frac{16 \times 200 \times 60}{\pi \times 10^3} = 61.1 \text{ N/mm}^2. \text{ Ans.}$$

(iii) Stiffness of the spring,

$$s = \frac{W}{\delta} = \frac{200}{34.5} = 5.8 \text{ N/mm. Ans.}$$

**Problem 16.38.** A close coiled helical spring of 10 cm mean diameter is made up of 1 cm diameter rod and has 20 turns. The spring carries an axial load of 200 N. Determine the shear stress. Taking the value of modulus of rigidity =  $8.4 \times 10^4 \text{ N/mm}^2$ , determine the deflection when carrying this load. Also calculate the stiffness of the spring and the frequency of free vibration for a mass hanging from it. (AMIE, Winter 1982)

**Sol. Given :**

$$\text{Mean diameter of coil, } D = 10 \text{ cm} = 100 \text{ mm}$$

$$\therefore \text{Mean radius of coil, } R = 5 \text{ cm} = 50 \text{ mm}$$

$$\text{Diameter of rod, } d = 1 \text{ cm} = 10 \text{ mm}$$

$$\text{Number of turns, } n = 20$$

$$\text{Axial load, } W = 200 \text{ N}$$

$$\text{Modulus of rigidity, } C = 8.4 \times 10^4 \text{ N/mm}^2$$

$$\text{Let } \tau = \text{Shear stress in the material of the spring}$$

$$\delta = \text{Deflection of the spring due to axial load}$$

$$s = \text{Stiffness of spring}$$

$$\tau = \text{Frequency of free vibration.}$$

Using equation (16.24),

$$\tau = \frac{16WR}{\pi d^3} = \frac{16 \times 200 \times 50}{\pi \times 10^3} = 50.93 \text{ N/mm}^2. \text{ Ans.}$$

Deflection of the spring

Using equation (16.26),

$$\delta = \frac{64WR^3 \times n}{Cd^4} = \frac{64 \times 200 \times 50^3 \times 20}{8.4 \times 10^4 \times 10^4} = 38.095 \text{ mm. Ans.}$$

Stiffness of the spring

$$\text{Stiffness} = \frac{\text{Load on spring}}{\text{Deflection of spring}} = \frac{200}{38.095} = 5.25 \text{ N/mm. Ans.}$$

Frequency of free vibration

$$\delta = 38.095 \text{ mm} = 3.8096 \text{ cm}$$

$$\text{Using the relation, } \tau = \frac{1}{2\pi} \sqrt{\frac{g}{\delta}} = \frac{1}{2\pi} \sqrt{\frac{981}{3.8095}} = 2.55 \text{ cycles/sec. Ans.}$$

**Problem 16.39.** A closely coiled helical spring of mean diameter 20 cm is made of 3 cm diameter rod and has 16 turns. A weight of 3 kN is dropped on this spring. Find the height by which the weight should be dropped before striking the spring so that the spring may be compressed by 18 cm. Take  $C = 8 \times 10^4 \text{ N/mm}^2$ .

Sol. Given :

$$\text{Mean dia. of coil, } D = 20 \text{ cm} = 200 \text{ mm}$$

$$\therefore \text{Mean radius of coil, } R = \frac{200}{2} = 100 \text{ mm}$$

$$\text{Dia. of spring rod, } d = 3 \text{ cm} = 30 \text{ mm}$$

$$\text{Number of turns, } n = 16$$

$$\text{Weight dropped, } W = 3 \text{ kN} = 3000 \text{ N}$$

$$\text{Compression of the spring, } \delta = 18 \text{ cm} = 180 \text{ mm}$$

$$\text{Modulus of rigidity, } C = 8 \times 10^4 \text{ N/mm}^2$$

Let  $h$  = Height through which the weight  $W$  is dropped

$W$  = Gradually applied load which produces the compression of spring equal to 180 mm.

Now using equation (16.26),

$$\delta = \frac{64W.R^3.n}{Cd^4}$$

$$180 = \frac{64 \times W \times 100^3 \times 16}{8 \times 10^4 \times 30^4}$$

$$W = \frac{180 \times 8 \times 10^4 \times 30^4}{64 \times 100^3 \times 16} = 11390 \text{ N}$$

Work done by the falling weight on spring

$$= \text{Weight falling } (h + \delta) = 3000 (h + 180) \text{ N-mm}$$

Energy stored in the spring =  $\frac{1}{2} W \times \delta$

$$= \frac{1}{2} \times 11390 \times 180 = 1025100 \text{ N-mm.}$$

Equating the work done by the falling weight on the spring to the energy stored in the spring, we get

$$3000(h + 180) = 1025100$$

$$h + 180 = \frac{1025100}{3000} = 341.7 \text{ mm}$$

$$\therefore h = 341.7 - 180 = 161.7 \text{ mm. Ans.}$$

**Problem 16.40.** The stiffness of a close-coiled helical spring is 1.5 N/mm of compression under a maximum load of 60 N. The maximum shearing stress produced in the wire of the

spring is 125 N/mm<sup>2</sup>. The solid length of the spring (when the coils are touching) is given as 5 cm. Find : (i) diameter of wire, (ii) mean diameter of the coils and (iii) number of coils required. Take  $C = 4.5 \times 10^4 \text{ N/mm}^2$ .

Sol. Given :

$$\text{Stiffness of spring, } s = 1.5 \text{ N/mm}$$

$$\text{Load on spring, } W = 60 \text{ N}$$

$$\text{Maximum shear stress, } \tau = 125 \text{ N/mm}^2$$

$$\text{Solid length of spring, } = 5 \text{ cm} = 50 \text{ mm}$$

$$\text{Modulus of rigidity, } C = 4.5 \times 10^4 \text{ N/mm}^2.$$

Let  $d$  = Diameter of wire,

$D$  = Mean dia. of coil, and

$$R = \text{Mean radius of coil} = \frac{D}{2}$$

$n$  = Number of coils.

Using equation (16.27),

$$s = \frac{Cd^4}{64.R^3.n} \quad \text{or} \quad 1.5 = \frac{4.5 \times 10^4 \times d^4}{64 \times R^3 \times n}$$

$$\therefore d^4 = \frac{1.5 \times 64 \times R^3 \times n}{4.5 \times 10^4} = 0.002133R^3 \times n \quad \dots(i)$$

Using equation (16.24),

$$\tau = \frac{16W \times R}{\pi d^3} \quad \text{or} \quad 125 = \frac{16 \times 60 \times R}{\pi d^3}$$

$$\therefore R = \frac{125 \times \pi d^3}{16 \times 60} = 0.40906d^3 \quad \dots(ii)$$

Substituting the value of  $R$  in equation (i), we get

$$d^4 = 0.002133 \times (0.40906d^3)^3 \times n \\ = 0.002133 \times (0.40906^3) \times d^9 \times n = 0.00014599 \times d^9 \times n$$

$$\text{or } \frac{d^9 \cdot n}{d^4} = \frac{1}{0.00014599} \quad \text{or} \quad d^5 \cdot n = \frac{1}{0.00014599} \quad \dots(iii)$$

Now using equation (16.28),

$$\text{Solid length} = n \times d \text{ or } 50 = n \times d$$

$$\therefore n = \frac{50}{d} \quad \dots(iv)$$

Substituting this value of  $n$  in equation (iii), we get

$$d^5 \times \frac{50}{d} = \frac{1}{0.00014599}$$

$$\text{or } d^4 = \frac{1}{0.00014599} \times \frac{1}{50} = 136.99$$

$$\therefore d = (136.99)^{1/4} = 3.42 \text{ mm. Ans.}$$

Substituting this value in equation (iv)

$$n = \frac{50}{d} = \frac{50}{3.42} = 14.62 \text{ say } 15. \text{ Ans.}$$

Also from equation (ii),

$$R = 0.40906 d^3 = 0.40906 \times (3.42)^3 = 16.36 \text{ mm}$$

i.e., Mean dia. of coil,  $D = 2R = 2 \times 16.36 = 32.72 \text{ mm}$ . **Ans.**

**Problem 16.41.** A close-coiled helical spring has a stiffness of 10 N/mm. Its length when fully compressed, with adjacent coils touching each other is 40 cm. The modulus of rigidity of the material of the spring is  $0.8 \times 10^5 \text{ N/mm}^2$ .

(i) Determine the wire diameter and mean coil diameter if their ratio is  $\frac{1}{10}$ .

(ii) If the gap between any two adjacent coil is 0.2 cm, what maximum load can be applied before the spring becomes solid, i.e., adjacent coils touch?

(iii) What is the corresponding maximum shear stress in the spring? (AMIE, May 1976)

**Sol.** Given :

Stiffness of spring,  $s = 10 \text{ N/mm}$

Length of spring when fully compressed i.e., solid length  
 $= 40 \text{ cm} = 400 \text{ mm}$

Modulus of rigidity,  $C = 0.8 \times 10^5 \text{ N/mm}^2$

Let  $d =$  Diameter of wire of spring

$D =$  Mean coil diameter

$n =$  Number of turns

$W =$  Maximum load applied when spring becomes solid

$\tau =$  Maximum shear stress induced in the wire.

Now 
$$\frac{d}{D} = \frac{1}{10}$$

Gap between any two adjacent coil = 0.2 cm = 2.0 mm

$\therefore$  Total gap in coils = Gap between two adjacent coil  $\times$  Number of turns  
 $= 2 \times n \text{ mm}$ .

When spring is fully compressed, there is no gap in the coils and hence maximum compression of the coil will be equal to the total gap in the coil.

$\therefore$  Maximum compression,  $\delta = 2 \times n \text{ mm}$

Now using equation (16.27),

$$s = \frac{Cd^4}{64 \cdot R^3 \cdot n} \quad \text{or} \quad 10 = \frac{0.8 \times 10^5 \times d^4}{64 \cdot R^3 \cdot n}$$

$$\therefore d^4 = \frac{10 \times 64 \times R^3 \times n}{0.8 \times 10^5} = \left(\frac{8}{10^3}\right) R^3 \times n \quad \dots(i)$$

But from equation (16.28),

Solid length =  $n \times d$  or  $400 = n \times d$ .

$$\therefore n = \frac{400}{d} \quad \dots(ii)$$

Substituting the value of  $n$  in equation (i),

$$d^4 = \left(\frac{8}{10^3}\right) \times R^3 \times \frac{400}{d} = 3.2 \times \frac{R^3}{d}$$

$$d^5 = 3.2 \times R^3.$$

or

But mean coil radius,

$$R = \frac{D}{2}$$

$$\therefore d^5 = 3.2 \times \left(\frac{D}{2}\right)^3 = \frac{3.2 \times D^3}{8} = 0.4 D^3$$

$$\text{or} \quad \frac{d^5}{D^3} = 0.4 \quad \text{or} \quad \frac{d^3}{D^3} \cdot d^2 = 0.4$$

$$\text{or} \quad \left(\frac{1}{10}\right)^3 \cdot d^2 = 0.4 \quad \left(\because \frac{d}{D} = \frac{1}{10}\right)$$

$$\therefore d^2 = 0.4 \times 10^3 = 400$$

$$\therefore d = \sqrt{400} = 20 \text{ mm} = 2 \text{ cm. Ans.}$$

$$\text{But} \quad \frac{d}{D} = \frac{1}{10}$$

$$\therefore D = 10 \times d = 10 \times 2 = 20.0 \text{ cm. Ans.}$$

Let us find first number of turns.

From equation (ii), we have

$$n = \frac{400}{d} = \frac{400}{20} = 20 \quad (\because d = 20)$$

$$\therefore \delta = 2 \times n = 2 \times 20 = 40 \text{ mm}$$

We know, stiffness of spring is given by

$$s = \frac{W}{\delta} \quad \text{or} \quad 10 = \frac{W}{40}$$

$$\therefore W = 10 \times 40 = 400 \text{ N. Ans.}$$

Using equation (16.24), we have

$$\begin{aligned} \tau &= \frac{16 \cdot W \cdot R}{\pi d^3} \\ &= \frac{16 \times 400 \times 100}{\pi \times 20^3} \quad \left(\because R = \frac{D}{2} = \frac{20}{2} = 10 \text{ cm} = 100 \text{ mm}\right) \\ &= 25.465 \text{ N/mm}^2. \text{ Ans.} \end{aligned}$$

**Problem 16.42.** Two close-coiled concentric helical springs of the same length, are wound out of the same wire, circular in cross-section and supports a compressive load 'P'. The inner spring consists of 20 turns of mean diameter 16 cm and the outer spring has 18 turns of mean diameter 20 cm. Calculate the maximum stress produced in each spring if the diameter of wire = 1 cm and  $P = 1000 \text{ N}$ . (AMIE, Summer 1989)

**Sol.** Given :

Total load supported,  $P = 1000 \text{ N}$

Both the springs are of the same length of the same material and having same dia. of wire. Hence values of  $L$ ,  $C$  and ' $d$ ' will be same.

For inner spring

No. of turns,  $n_i = 20$

Mean dia.,  $D_i = 16 \text{ cm} = 160 \text{ mm} \quad \therefore R_i = \frac{160}{2} = 80 \text{ mm}$

Dia. of wire,  $d_i = 1 \text{ cm} = 10 \text{ mm}$

For outer spring

No. of turns,  $n_0 = 18$

Mean dia.,  $D_0 = 20 \text{ cm} = 200 \text{ mm} \therefore R_0 = \frac{200}{2} = 100 \text{ mm}$

Dia. of wire,  $d_0 = 1 \text{ cm} = 10 \text{ mm}$

Let  $W_i =$  Load carried by inner spring

$W_0 =$  Load carried by outer spring

$\tau_i =$  Max. shear stress produced in inner spring

$\tau_0 =$  Max. shear stress produced in outer spring.

Now  $W_i + W_0 =$  Total load carried = 1000 ... (i)

Since there are two close-coiled concentric helical springs, hence deflection of both the springs will be same.

$\therefore \delta_0 = \delta_i$  where  $\delta_0 =$  Deflection of outer spring  
 $\delta_i =$  Deflection of inner spring.

The deflection of close-coiled spring is given by equation (16.26) as

$$\delta = \frac{64W \times R^3 \times n}{C \times d^4}$$

Hence for outer spring, we have

$$\delta_0 = \frac{64W_0 \times R_0^3 \times n_0}{C \times d_0^4} = \frac{64W_0 \times 100^3 \times 18}{C \times 10^4} \quad (\because R_0 = 100, d_0 = 10)$$

Similarly for inner spring, we have

$$\delta_i = \frac{64W_i \times R_i \times n_i}{C \times d_i^4} = \frac{64W_i \times 80^3 \times 20}{C \times 10^4}$$

(Material of wires is same. Hence value of  $C$  will be same.)

But  $\delta_0 = \delta_i$

$$\therefore \frac{64W_0 \times 100^3 \times 18}{C \times 10^4} = \frac{64W_i \times 80^3 \times 20}{C \times 10^4}$$

or  $W_0 \times 100^3 \times 18 = W_i \times 80^3 \times 20$

$$W_0 = \frac{W_i \times 80^3 \times 20}{100^3 \times 18} = 0.569 W_i$$

Substituting the value of  $W_0$  in equation (i), we get

$$W_i + 0.569 W_i = 1000 \text{ or } 1.569 W_i = 1000$$

$$\therefore W_i = \frac{1000}{1.569} = 637.3 \text{ N.}$$

But from equation (i),  $W_i + W_0 = 1000$

$$\therefore W_0 = 1000 - W_i = 1000 - 637.3 = 362.7 \text{ N.}$$

The maximum shear stress produced is given by equation (16.24) as

$$\tau = \frac{16WR}{\pi d^3}$$

For outer spring, the maximum shear stress produced is given by,

$$\tau_0 = \frac{64W_0 \times R_0}{\pi d_0^3} = \frac{16 \times 362.7 \times 100}{\pi \times 10^3} = 184.72 \text{ N/mm}^2. \text{ Ans.}$$

Similarly for inner spring, the maximum shear stress produced is given by,

$$\tau_i = \frac{16 \times W_i \times R_i}{\pi \times d_i^3} = \frac{16 \times 637.3 \times 80}{\pi \times 10^3} = 259.66 \text{ N/mm}^2. \text{ Ans.}$$

**Problem 16.43.** A closely coiled helical spring made of 10 mm diameter steel wire has 15 coils of 100 mm mean diameter. The spring is subjected to an axial load of 100 N. Calculate :

(i) The maximum shear stress induced,

(ii) The deflection, and

(iii) Stiffness of the spring.

Take modulus of rigidity,  $C = 8.16 \times 10^4 \text{ N/mm}^2$ .

(AMIE, Winter 1990 ; Converted to S.I. units)

**Sol.** Given :

Dia. of wire,  $d = 10 \text{ mm}$

Number of coils,  $n = 15$

Mean dia. of coil,  $D = 100 \text{ mm}$

$$\therefore \text{Mean radius of coil, } R = \frac{100}{2} = 50 \text{ mm}$$

Axial load,  $W = 100 \text{ N}$

Modulus of rigidity,  $C = 8.16 \times 10^4 \text{ N/mm}^2$ .

(i) Maximum shear stress induced

$$\text{Using equation (16.24), } \tau = \frac{16WR}{\pi d^3} = \frac{16 \times 100 \times 50}{\pi \times 10^3} = 24.46 \text{ N/mm}^2. \text{ Ans.}$$

(ii) The deflection ( $\delta$ )

Using equation (16.26),

$$\delta = \frac{64W \times R^3 \times n}{C \times d^4} = \frac{64 \times 100 \times 50^3 \times 15}{8.16 \times 10^4 \times 10^4} = 14.7 \text{ mm. Ans.}$$

(iii) Stiffness of the spring

$$\text{Stiffness} = \frac{\text{Load on spring}}{\text{Deflection of spring}}$$

$$= \frac{\text{Load on spring}}{\text{Deflection of spring}} = \frac{100}{14.7} = 6.802 \text{ N/mm. Ans.}$$

## HIGHLIGHTS

1. A shaft is in torsion, when equal and opposite torques are applied at the two ends of a shaft.
2. The relation of maximum shear stress induced in a shaft subjected to twisting moment is given by

$$\frac{\tau}{R} = \frac{C\theta}{L}$$

where  $\tau$  = Maximum shear stress,  
 $R$  = Radius of shaft,  
 $C$  = Modulus of rigidity,  
 $\theta$  = Angle of twist in radian, and  
 $L$  = Length of the shaft.

3. When a circular shaft is subjected to torsion, the shear stress at any point varies linearly from the axis to the surface i.e.,

$$\frac{\tau}{R} = \frac{q}{r}$$

where  $\tau$  = Maximum shear stress on the surface of the shaft  
 $R$  = Radius of surface  
 $q$  = Shear stress at a point which is at a radius 'r'.

4. The shear stress is maximum on the surface of the shaft and is zero at the axis of the shaft.
5. The torque transmitted by a solid shaft is given by

$$T = \frac{\pi}{16} \tau D^3$$

where  $D$  = Dia. of solid shaft and  
 $\tau$  = Max. shear stress.

6. The torque transmitted by a hollow circular shaft is given by

$$T = \frac{\pi}{16} \tau \left( \frac{D_0^4 - D_i^4}{D_0} \right)$$

where  $D_0$  = External diameter, and  
 $D_i$  = Internal diameter.

7. Relation between torque, polar moment of inertia and shear stress is given as

$$\frac{T}{J} = \frac{\tau}{R} = \frac{C\theta}{L}$$

where  $I$  = Polar moment of inertia

$$= \frac{\pi}{32} D^4 \quad \dots \text{For a solid shaft}$$

$$= \frac{\pi}{32} [D_0^4 - D_i^4] \quad \dots \text{For a hollow shaft.}$$

8. The ratio of the polar moment of inertia to the radius of the shaft is known as polar modulus or torsional section modulus. It is denoted by  $Z_p$ .

$$Z_p = \frac{J}{R}$$

$$= \frac{\pi}{16} D^3 \quad \dots \text{For a solid shaft}$$

$$= \frac{\pi}{16D_0} [D_0^4 - D_i^4] \quad \dots \text{For a hollow shaft.}$$

9. Strength of a shaft means the maximum torque or maximum power the shaft can transmit.
10. The product of modulus of rigidity and polar moment of inertia of a shaft is known as torsional rigidity or stiffness of the shaft. Mathematically,

$$\text{Torsional rigidity} = C \times J$$

$$= \frac{T \times L}{\theta}$$

$$= T \text{ if } L = 1 \text{ metre and } \theta = \text{one radian.}$$

$$\left( \because \frac{T}{J} = \frac{C\theta}{L} \therefore C \times J = \frac{T \times L}{\theta} \right)$$

11. The power transmitted by a shaft is given by

$$P = \frac{2\pi NT}{60}$$

12. The strain energy stored in a shaft due to torsion is given by,

$$U = \frac{\tau^2}{4C} \times V \quad \dots \text{For a solid shaft}$$

$$= \frac{\tau}{4C \cdot D^2} (D^2 + d^2) \times V \quad \dots \text{For a hollow shaft}$$

where  $D$  = External diameter of shaft,  
 $d$  = Internal diameter of shaft,  
 $T$  = Modulus of rigidity, and  
 $\tau$  = Shear stress on the surface of the shaft.

13. Polar moment of inertia ( $J$ ) is given by

$$J = \frac{\pi}{32} D^4 \quad \dots \text{For a solid shaft}$$

$$= \frac{\pi}{32} (D^4 - d^4) \quad \dots \text{For hollow shaft.}$$

14. Springs are the elastic bodies which absorb energy due to resilience. Two important types of springs are :

1. Laminated or leaf springs and
2. Helical springs.

15. The maximum stress developed in the plates of a leaf spring is given by,

$$\sigma = \frac{3 \cdot W \cdot l}{2n \cdot b \cdot t^2}$$

where  $W$  = Point load acting at the centre of leaf spring,  
 $l$  = Span of leaf spring or length of leaf spring,  
 $n$  = Number of plates,  
 $b$  = Width of each plate, and  
 $t$  = Thickness of each plate.

16. The central deflection ( $\delta$ ) of the laminated spring is given by,

$$\delta = \frac{\sigma \cdot l^2}{4E \cdot t}$$

where  $\sigma$  = Maximum stress developed in the plates,  
 $E$  = Modulus of elasticity,  
 $l$  = Length of leaf spring, and  
 $t$  = Thickness of each plate.

17. Helical springs are the thick spring wires coiled into a helix. They are of two types :

1. Close-coiled helical springs and
2. Open-coiled helical spring.

18. The maximum shear stress induced in the wire of a close-coiled helical spring which carries an axial load is given by,

$$\tau = \frac{16 \cdot W \cdot R}{\pi d^3}$$

where  $W$  = Axial load on the spring,  
 $R$  = Mean radius of spring coil, and  
 $d$  = Diameter of spring wire.

19. For a close-coiled helical spring which carries an axial load, we have  
 (i) Strain energy stored,

$$U = \frac{32 \cdot W^2 \cdot R^3 \cdot n}{Cd^4}$$

(ii) The deflection of the spring at the centre due to axial load is given as

$$\delta = \frac{64 \cdot W \cdot R^3 \cdot n}{Cd^4} \text{ and}$$

(iii) The stiffness of the spring,

$$s = \frac{Cd^4}{64 \cdot R^3 \cdot n}$$

where  $W$  = Axial load on the spring,  
 $n$  = Number of coils,  
 $C$  = Modulus of rigidity, and  
 $R$  = Mean radius of spring coil.

### EXERCISE 16

#### (A) Theoretical Problems

- Define the terms : Torsion, torsional rigidity and polar moment of inertia.
- Derive an expression for the shear stress produced in a circular shaft which is subject to torsion. What are the assumptions made in the derivation?
- Prove that the torque transmitted by a solid shaft when subjected to torsion is given by

$$T = \frac{\pi}{16} \tau D^3$$

where  $D$  = Dia. of solid shaft and  $\tau$  = Max. shear stress.

- When a circular shaft is subjected to torsion show that the shear stress varies linearly from the axis to the surface. (AMIE, Winter 1982)
- Derive the relation for a circular shaft when subjected to torsion as given below

$$\frac{T}{J} = \frac{\tau}{R} = \frac{C\theta}{L}$$

where  $T$  = Torque transmitted,  
 $J$  = Polar moment of inertia,  
 $\tau$  = Max. shear stress,  
 $R$  = Radius of the shaft,  
 $C$  = Modulus of rigidity,  
 $\theta$  = Angle of twist, and  
 $L$  = Length of the shaft.

- Find an expression for the torque transmitted by a hollow circular shaft of external diameter =  $D_0$  and internal diameter =  $D_1$ .

- Define the term 'Polar modulus'. Find the expressions for polar modulus for a solid shaft and for a hollow shaft.
- What do you mean by 'strength of a shaft'?
- Define torsional rigidity of a shaft. Prove that the torsional rigidity is the torque required to produce a twist of one radian in a unit length of the shaft.
- Prove that the strain energy stored in a body due to shear stress is given by,

$$U = \frac{\tau^2}{2C} \times V$$

where  $\tau$  = Shear stress,  
 $C$  = Modulus of rigidity, and  
 $V$  = Volume of the body.

- Find an expression for strain energy stored in a body which due to torsion or Prove that the strain energy stored in a body due to torsion is given by,

$$U = \frac{\tau^2}{4C} \times V$$

where  $\tau$  = Shear stress on the surface of the shaft,  
 $C$  = Modulus of rigidity, and  $V$  = Volume of the body.

- A hollow shaft of external diameter  $D$  and internal diameter  $d$  is subjected to torsion, prove that the strain energy stored is given by,

$$U = \frac{\tau^2}{4CD^2} (D^2 + d^2) \times V$$

where  $V$  = Volume of the hollow shaft and  
 $\tau$  = Shear stress on the surface of the shaft.

- What is a spring? Name the two important types of spring.
- Prove that the maximum stress developed in the plates of a leaf spring is given by

$$\sigma = \frac{3W \cdot l}{2n \cdot b \cdot t^2}$$

where  $W$  = Point load acting at the centre of leaf spring,  
 $l$  = Span of leaf spring or length of the leaf spring,  
 $n$  = Number of plates,  
 $b$  = Width of each plate, and  
 $t$  = Thickness of each plate.

- Prove that the central deflection of the laminated spring (or leaf spring) is given by

$$\delta = \frac{\sigma \times l^2}{4Et}$$

where  $\sigma$  = Maximum stress developed in plates,  
 $E$  = Modulus of elasticity,  
 $l$  = Length of leaf spring, and  
 $t$  = Thickness of each plate.

- Define helical springs. Name the two important types of helical springs.
- Prove that the maximum shear stress induced in the wire of a close-coiled helical spring is given by

$$\tau = \frac{16 \cdot W \cdot R}{\pi d^3}$$

where  $\tau$  = Maximum shear stress induced in the wire,  
 $W$  = Axial load on spring,  
 $R$  = Mean radius of spring coil, and  $d$  = Diameter of spring wire.



18. Find an expression for the strain energy stored by the close-coiled helical spring when subjected to axial load  $W$ .
19. Prove that the deflection of a close-coiled helical spring at the centre due to axial load  $W$  is given by

$$\delta = \frac{64 \cdot W \cdot R^3 \cdot n}{Cd^4}$$

where  $R$  = Mean radius of spring coil,  
 $n$  = Number of coils,  
 $C$  = Modulus of rigidity, and  
 $d$  = Diameter of spring wire.

### (B) Numerical Problems

1. A solid shaft of 20 cm diameter is used to transmit torque. Find the maximum torque transmitted by the shaft if the maximum shear stress induced in the shaft is 50 N/mm<sup>2</sup>.  
 [Ans. 78539.8 Nm]
2. The shearing stress in a solid shaft is not to exceed 45 N/mm<sup>2</sup> when the torque transmitted is 40000 N-m. Determine the minimum diameter of the shaft.  
 [Ans. 16.49 cm]
3. Find the maximum torque transmitted by a hollow circular shaft of external diameter 30 cm and internal diameter 15 cm if the shear stress is not to exceed 40 N/mm<sup>2</sup>.  
 [Ans. 198.8 kNm]
4. Two shafts of the same material and of same lengths are subjected to the same torque, if the first shaft is of a solid circular section and the second shaft is of hollow circular section, whose internal diameter is 0.7 times the outside diameter and the maximum shear stress developed in each shaft is the same, compare the weights of the shafts.  
 [Ans.  $\frac{1.633}{1}$ ]
5. Find the maximum shear stress induced in a solid circular shaft of diameter 20 cm when the shaft transmit 187.5 kW at 200 r.p.m.  
 [Ans. 5.7 N/mm<sup>2</sup>]
6. A solid circular shaft is to transmit 375 kW at 150 r.p.m.  
 (i) Find the diameter of the shaft if the shear stress is not to exceed 65 N/mm<sup>2</sup>.  
 (ii) What per cent saving in weight would be obtained if this shaft is replaced by a hollow shaft whose internal diameter equal to 2/3rd of its external diameter, the length, the material and maximum shear stress being the same?  
 [Ans. (i) 12.29 cm (ii) 35.71%]
7. A solid shaft has to transmit 112.5 kW at 250 r.p.m. Taking allowable shear stress as 70 N/mm<sup>2</sup>, find suitable diameter for the shaft, if the maximum torque transmitted at each revolution exceeds the mean by 20%.  
 [Ans. 7.20 cm]
8. A hollow shaft is to transmit 337.5 kW at 100 r.p.m. If the shear stress is not to exceed 65 N/mm<sup>2</sup> and the internal diameter is 0.6 of the external diameter, find the external and internal diameters assuming that the maximum torque is 1.3 times the mean.  
 [Ans. 15.52 cm, 9.312 cm]
9. Determine the diameter of a solid steel shaft which will transmit 112.5 kW at 200 r.p.m. Also determine the length of the shaft if the twist must not exceed 1.5° over the entire length. The maximum shear stress is limited to 55 N/mm<sup>2</sup>. Take the value of modulus of rigidity =  $8 \times 10^4$  N/mm<sup>2</sup>.  
 [Ans. 7.9 cm, 150.4 cm]
10. Determine the diameter of a solid shaft which will transmit 337.5 kW at 300 r.p.m. The maximum shear stress should not exceed 35 N/mm<sup>2</sup> and twist should not be more than 1° in a shaft length of 2.5 m. Take modulus of rigidity =  $9 \times 10^4$  N/mm<sup>2</sup>.  
 [Ans. 11.57 cm]
11. A hollow shaft, having an internal diameter 50% of its external diameter transmits 600 kW at 150 r.p.m. Determine the external diameter of the shaft if the shear stress is not to exceed 65 N/mm<sup>2</sup> and the twist in a length of 3 m should not exceed 1.4 degrees. Assume maximum torque = 1.20 mean torque and modulus of rigidity =  $1 \times 10^5$  N/mm<sup>2</sup>.  
 [Ans. 15.70 cm]

12. Two shafts are connected end to end by means of a flanged coupling in which there are 12 bolts, the pitch circle diameter being 30 cm. The maximum shear stress is limited to 60 N/mm<sup>2</sup> in the shafts and 25 N/mm<sup>2</sup> in the bolts. If one shaft is solid of 6 cm diameter and the other is hollow of 12 cm external diameter, calculate the internal diameter of the hollow shaft and the bolt diameter so that both shafts and the coupling are all equally strong in torsion.  
 [Ans. 11.6 cm, 0.848 cm]
13. A hollow shaft of 1.5 m long has external diameter 60 mm. It has 30 mm internal diameter for a part of the length and 40 mm internal diameter for the rest of the length. If the maximum shear stress in it is not to exceed 85 N/mm<sup>2</sup>, determine the maximum horse power transmitted by it at a speed of 350 r.p.m. If the twists produced in the two portions of the shafts are equal find the lengths of the two portions.  
 [Ans. 141.37, 808.23 mm, 691.77 mm]
14. A leaf spring carries a central load of 2.5 kN. The leaf spring is to be made of 10 steel plate 6 cm wide and 5 mm thick. If the bending stress is limited to 100 N/mm<sup>2</sup> determine: (i) length of the spring and deflection at the centre of the spring. Take  $E = 2 \times 10^5$  N/mm<sup>2</sup>. [Ans. 40 cm, 0.4 cm]
15. A laminated spring 0.9 m long is made up of plates each 5 cm wide and 1 cm thick. If the bending stress in the plate is limited to 120 N/mm<sup>2</sup>, how many plates would be required to enable the spring to carry a central point load of 2.65 kN? If  $E = 2.0 \times 10^5$  N/mm<sup>2</sup>, what is the deflection under the load?  
 [Ans. 6 plates, 1.215 cm]
16. A closely-coiled helical spring is to carry a load of 1 kN. Its mean coil diameter is to be 10 times that of wire diameter. Calculate these diameters if the maximum shear stress in the material of the spring is to be 90 N/mm<sup>2</sup>.  
 [Ans. 16.82 cm and 1.68 cm]
17. In question 16, if the stiffness of the spring is 20 N/mm deflection and modulus of rigidity =  $8.4 \times 10^4$  N/mm<sup>2</sup>, find the number of coils in the closely-coiled helical spring.  
 [Ans. 9]
18. A closely-coiled helical spring of round steel wire 8 mm in diameter having 10 complete turns with a mean diameter of 10 cm is subjected to an axial load of 250 N. Determine: (i) the deflection of the spring, (ii) maximum shear stress in the wire and (iii) stiffness of the spring. Take  $C = 8 \times 10^4$  N/mm<sup>2</sup>.  
 [Ans. (i) 6.1 cm, (ii) 124.34 N/mm<sup>2</sup>, (iii) 4.1 N/mm<sup>2</sup>]
19. A close-coiled helical spring of 10 cm mean diameter is made up of 1.0 cm diameter rod and has 20 turns. The spring carried an axial load of 300 N. Determine the shearing stress. Taking the value of modulus of rigidity =  $8.2 \times 10^4$  N/mm<sup>2</sup>, determine the deflection when carrying this load. Also calculate the stiffness of the spring and frequency of free vibration for a mass hanging from it.  
 [Ans. 76.4 N/mm<sup>2</sup>, 5.71 cm, 5.25 N/mm and 2.08 cycles/sec]

# 17

## Thin Cylinders and Spheres

### 17.1. INTRODUCTION

The vessels such as boilers, compressed air receivers etc., are of cylindrical and spherical forms. These vessels are generally used for storing fluids (liquid or gas) under pressure. The walls of such vessels are thin as compared to their diameters. If the thickness of the wall of the cylindrical vessel is less than  $\frac{1}{15}$  to  $\frac{1}{20}$  of its internal diameter, the cylindrical vessel is known as a *thin cylinder*. In case of thin cylinders, the stress distribution is assumed uniform over the thickness of the wall.

### 17.2. THIN CYLINDRICAL VESSEL SUBJECTED TO INTERNAL PRESSURE

Fig. 17.1 shows a thin cylindrical vessel in which a fluid under pressure is stored.

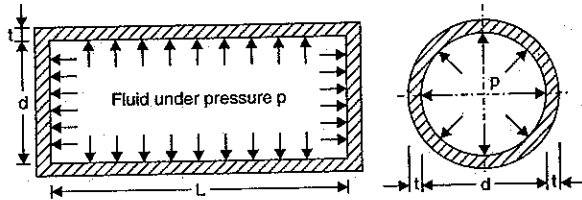

Fig. 17.1

- Let  $d$  = Internal diameter of the thin cylinder  
 $t$  = Thickness of the wall of the cylinder  
 $p$  = Internal pressure of the fluid  
 $L$  = Length of the cylinder.

On account of the internal pressure  $p$ , the cylindrical vessel may fail by splitting up in any one of the two ways as shown in Fig. 17.2 (a) and 17.2 (b).

The forces, due to pressure of the fluid acting vertically upwards and downwards on the thin cylinder, tend to burst the cylinder as shown in Fig. 17.2 (a).

The forces, due to pressure of the fluid, acting at the ends of the thin cylinder, tend to burst the thin cylinder as shown in Fig. 17.2 (b).

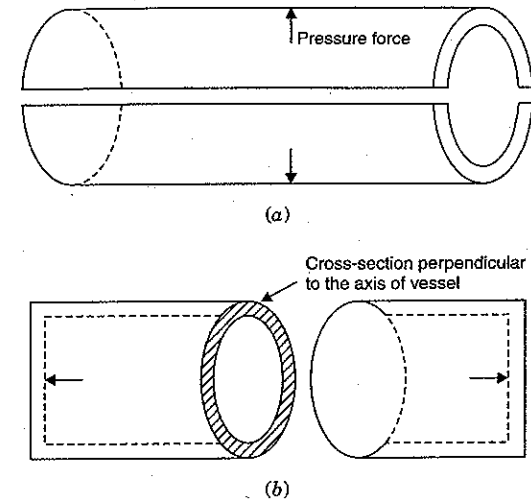

Fig. 17.2

### 17.3. STRESSES IN A THIN CYLINDRICAL VESSEL SUBJECTED TO INTERNAL PRESSURE

When a thin cylindrical vessel is subjected to internal fluid pressure, the stresses in the wall of the cylinder on the cross-section along the axis and on the cross-section perpendicular to the axis are set up. These stresses are tensile and are known as :

1. Circumferential stress (or hoop stress) and
2. Longitudinal stress.

The name of the stress is given according to the direction in which the stress is acting. The stress acting along the circumference of the cylinder is called circumferential stress whereas the stress acting along the length of the cylinder (*i.e.*, in the longitudinal direction) is known as longitudinal stress. The circumferential stress is also known as *hoop stress*. The stress set up in Fig. 17.2 (a) is circumferential stress whereas the stress set up in Fig. 17.2 (b) is longitudinal stress.

### 17.4. EXPRESSION FOR CIRCUMFERENTIAL STRESS (OR HOOP STRESS)

Consider a thin cylindrical vessel subjected to an internal fluid pressure. The circumferential stress will be set up in the material of the cylinder, if the bursting of the cylinder takes place as shown in Fig. 17.3 (a).

The expression for hoop stress or circumferential stress ( $\sigma_1$ ) is obtained as given below.

- Let  $p$  = Internal pressure of fluid  
 $d$  = Internal diameter of the cylinder  
 $t$  = Thickness of the wall of the cylinder  
 $\sigma_1$  = Circumferential or hoop stress in the material.

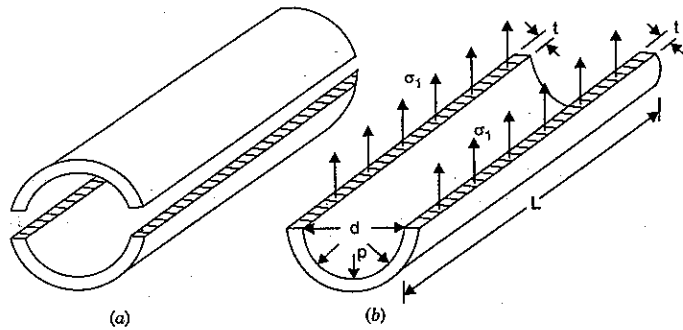

Fig. 17.3

The bursting will take place if the force due to fluid pressure is more than the resisting force due to circumferential stress set up in the material. In the limiting case, the two forces should be equal.

$$\begin{aligned} \text{Force due to fluid pressure} &= p \times \text{Area on which } p \text{ is acting} \\ &= p \times (d \times L) \end{aligned} \quad \dots(i)$$

$$(\because p \text{ is acting on projected area } d \times L)$$

$$\begin{aligned} \text{Force due to circumferential stress} &= \sigma_1 \times \text{Area on which } \sigma_1 \text{ is acting} \\ &= \sigma_1 \times (L \times t + L \times t) \\ &= \sigma_1 \times 2Lt = 2\sigma_1 \times L \times t \end{aligned} \quad \dots(ii)$$

Equating (i) and (ii), we get

$$p \times d \times L = 2\sigma_1 \times L \times t$$

$$\therefore \sigma_1 = \frac{pd}{2t} \quad (\text{cancelling } L) \quad \dots(17.1)$$

This stress is tensile as shown in Fig. 17.3 (b).

### 17.5. EXPRESSION FOR LONGITUDINAL STRESS

Consider a thin cylindrical vessel subjected to internal fluid pressure. The longitudinal stress will be set up in the material of the cylinder, if the bursting of the cylinder takes place along the section AB of Fig. 17.4 (a).

The longitudinal stress ( $\sigma_2$ ) developed in the material is obtained as :

Let  $p$  = Internal pressure of fluid stored in thin cylinder

$d$  = Internal diameter of cylinder

$t$  = Thickness of the cylinder

$\sigma_2$  = Longitudinal stress in the material.

The bursting will take place if the force due to fluid pressure acting on the ends of the cylinder is more than the resisting force due to longitudinal stress ( $\sigma_2$ ) developed in the material as shown in Fig. 17.4 (b). In the limiting case, both the forces should be equal.

$$\begin{aligned} \text{Force due to fluid pressure} &= p \times \text{Area on which } p \text{ is acting} \\ &= p \times \frac{\pi}{4} d^2 \end{aligned}$$

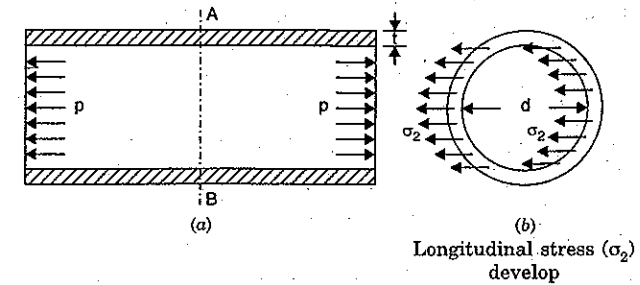

Fig. 17.4

$$\begin{aligned} \text{Resisting force} &= \sigma_2 \times \text{Area on which } \sigma_2 \text{ is acting} \\ &= \sigma_2 \times \pi d \times t \end{aligned}$$

$\therefore$  Hence in the limiting case

Force due to fluid pressure = Resisting force

$$p \times \frac{\pi}{4} d^2 = \sigma_2 \times \pi d \times t$$

$$\therefore \sigma_2 = \frac{p \times \frac{\pi}{4} d^2}{\pi d \times t} = \frac{pd}{4t} \quad \dots(17.2)$$

The stress  $\sigma_2$  is also tensile.

Equation (17.2) can be written as

$$\sigma_2 = \frac{pd}{2 \times 2t} = \frac{1}{2} \times \sigma_1 \quad \left( \because \sigma_1 = \frac{pd}{2t} \right)$$

or Longitudinal stress = Half of circumferential stress.

This also means that circumferential stress ( $\sigma_1$ ) is two times the longitudinal stress ( $\sigma_2$ ). Hence in the material of the cylinder the permissible stress should be less than the circumferential stress. Or in other words, the circumferential stress should not be greater than the permissible stress.

**Maximum shear stress.** At any point in the material of the cylindrical shell, there are two principal stresses, namely a circumferential stress of magnitude  $\sigma_1 = \frac{pd}{2t}$  acting circumferentially and a longitudinal stress of magnitude  $\sigma_2 = \frac{pd}{4t}$  acting parallel to the axis of the shell. These two stresses are tensile and perpendicular to each other.

$$\therefore \text{Maximum shear stress } \tau_{\max} = \frac{\sigma_1 - \sigma_2}{2} = \frac{\frac{pd}{2t} - \frac{pd}{4t}}{2} = \frac{pd}{8t} \quad \dots[17.2 (A)]$$

**Note.** (i) If the thickness of the thin cylinder is to be determined then equation (17.1) should be used.

(ii) If maximum permissible stress in the material is given. This stress should be taken circumferential stress ( $\sigma_1$ ).

(iii) While using equations (17.1) and (17.2), the units of  $p$ ,  $\sigma_1$  and  $\sigma_2$  should be same. They should be expressed either in  $\text{N/mm}^2$  or  $\text{N/m}^2$ . Also the units of  $d$  and  $t$  should be same. They may be in metre (m) or millimetre (mm).

**Problem 17.1.** A cylindrical pipe of diameter 1.5 m and thickness 1.5 cm is subjected to an internal fluid pressure of 1.2 N/mm<sup>2</sup>. Determine :

- (i) Longitudinal stress developed in the pipe, and  
 (ii) Circumferential stress developed in the pipe.

**Sol. Given :**

Dia. of pipe,  $d = 1.5$  m  
 Thickness,  $t = 1.5$  cm =  $1.5 \times 10^{-2}$  m  
 Internal fluid pressure,  $p = 1.2$  N/mm<sup>2</sup>

As the ratio  $\frac{t}{d} = \frac{1.5 \times 10^{-2}}{1.5} = \frac{1}{100}$ , which is less than  $\frac{1}{20}$ , hence this is a case of thin cylinder.

Here unit of pressure ( $p$ ) is in N/mm<sup>2</sup>. Hence the unit of  $\sigma_1$  and  $\sigma_2$  will also be in N/mm<sup>2</sup>.

(i) The longitudinal stress ( $\sigma_2$ ) is given by equation (17.2) as,

$$\begin{aligned}\sigma_2 &= \frac{p \times d}{4t} \\ &= \frac{1.2 \times 1.5}{4 \times 1.5 \times 10^{-2}} = 30 \text{ N/mm}^2. \text{ Ans.}\end{aligned}$$

(ii) The circumferential stress ( $\sigma_1$ ) is given by equation (17.1) as

$$\begin{aligned}\sigma_1 &= \frac{pd}{2t} \\ &= \frac{1.2 \times 1.5}{2 \times 1.5 \times 10^{-2}} = 60 \text{ N/mm}^2. \text{ Ans.}\end{aligned}$$

**Problem 17.2.** A cylinder of internal diameter 2.5 m and of thickness 5 cm contains a gas. If the tensile stress in the material is not to exceed 80 N/mm<sup>2</sup>, determine the internal pressure of the gas.

**Sol. Given :**

Internal dia. of cylinder,  $d = 2.5$  m  
 Thickness of cylinder,  $t = 5$  cm =  $5 \times 10^{-2}$  m  
 Maximum permissible stress = 80 N/mm<sup>2</sup>

As maximum permissible stress is given. Hence this should be equal to circumferential stress ( $\sigma_1$ ).

We know that the circumferential stress should not be greater than the maximum permissible stress. Hence take circumferential stress equal to maximum permissible stress.

$$\therefore \sigma_1 = 80 \text{ N/mm}^2$$

Let  $p$  = Internal pressure of the gas

Using equation (17.1),

$$\begin{aligned}\sigma_1 &= \frac{pd}{2t} \\ p &= \frac{2t \times \sigma_1}{d} = \frac{2 \times 5 \times 10^{-2} \times 80}{2.5} \quad (\text{Here unit of } \sigma_1 \text{ is in N/mm}^2, \\ &\quad \text{hence unit of } p \text{ will also be in N/mm}^2) \\ &= 3.2 \text{ N/mm}^2. \text{ Ans.}\end{aligned}$$

**Problem 17.3.** A cylinder of internal diameter 0.50 m contains air at a pressure of 7 N/mm<sup>2</sup> (gauge). If the maximum permissible stress induced in the material is 80 N/mm<sup>2</sup>, find the thickness of the cylinder.

**Sol. Given :**

Internal dia. of cylinder,  $d = 0.50$  m  
 Internal pressure of air,  $p = 7$  N/mm<sup>2</sup>

Maximum permissible stress in the material means the circumferential stress ( $\sigma_1$ ).

As stated earlier that the circumferential stress should not be greater than the maximum permissible stress. Hence take circumferential stress equal to maximum permissible stress.

$$\therefore \text{Circumferential stress, } \sigma_1 = 80 \text{ N/mm}^2$$

Let  $t$  = Thickness of the cylinder

Using equation (17.1),

$$\begin{aligned}\sigma_1 &= \frac{pd}{2t} \\ \therefore t &= \frac{pd}{2 \times \sigma_1} = \frac{7 \times 0.50}{2 \times 80} = 0.021875 \text{ m} \\ &\quad (\text{Here } p \text{ and } \sigma_1 \text{ are in N/mm}^2, d \text{ is in } m \text{ hence } t \text{ will be in } m) \\ &= 2.188 \text{ cm. Ans.}\end{aligned}$$

If the value of  $t$  is taken 2.1875 cm, the stress induced will be 80 N/mm<sup>2</sup>. If the value of  $t$  is less than 2.1875 cm, the stress induced will be more than 80 N/mm<sup>2</sup>. But the stress induced should not be more than 80 N/mm<sup>2</sup>. If the value of  $t$  is taken more than 2.1875 cm (say  $t = 2.188$  cm), the stress induced will be less than 80 N/mm<sup>2</sup>.

Hence take  $t = 2.188$  cm or say 2.2 cm. Ans.

**Problem 17.4.** A thin cylinder of internal diameter 1.25 m contains a fluid at an internal pressure of 2 N/mm<sup>2</sup>. Determine the maximum thickness of the cylinder if :

(i) The longitudinal stress is not to exceed 30 N/mm<sup>2</sup>.

(ii) The circumferential stress is not to exceed 45 N/mm<sup>2</sup>.

**Sol. Given :**

Internal dia. of cylinder,  $d = 1.25$  m  
 Internal pressure of fluid,  $p = 2$  N/mm<sup>2</sup>  
 Longitudinal stress,  $\sigma_2 = 30$  N/mm<sup>2</sup>  
 Circumferential stress,  $\sigma_1 = 45$  N/mm<sup>2</sup>

Using equation (17.1),

$$\begin{aligned}\sigma_1 &= \frac{pd}{2t} \\ \therefore t &= \frac{p \times d}{2 \times \sigma_1} = \frac{2 \times 1.25}{2 \times 45} = 0.0277 \text{ m} \\ &= 2.77 \text{ cm.} \quad \dots(i)\end{aligned}$$

Using equation (17.2),

$$\begin{aligned}\sigma_2 &= \frac{pd}{4t} \\ \therefore t &= \frac{pd}{4 \times \sigma_2} = \frac{2 \times 1.25}{4 \times 30} = 0.0208 \text{ m} \\ &= 2.08 \text{ cm.} \quad \dots(ii)\end{aligned}$$

The longitudinal or circumferential stresses induced in the material are inversely proportional to the thickness ( $t$ ) of the cylinder. Hence the stress induced will be less if the value of  $t$  is more. Hence take the maximum value of  $t$  calculated in equations (i) and (ii)

From the equations (i) and (ii) it is clear that  $t$  should not be less than 2.77 cm.

Take  $t = 2.80$  cm. Ans.

**Problem 17.5.** A water main 80 cm diameter contains water at a pressure head of 100 m. If the weight density of water is 9810 N/m<sup>3</sup>, find the thickness of the metal required for the water main. Given the permissible stress as 20 N/mm<sup>2</sup>. (AMIE, Summer 1974)

**Sol.** Given :

Dia. of main,  $d = 80$  cm

Pressure head of water,  $h = 100$  m

Weight density of water,  $w = \rho \times g = 1,000 \times 9.81 = 9810$  N/m<sup>3</sup>

Permissible stress = 20 N/mm<sup>2</sup>

Permissible stress is equal to circumferential stress ( $\sigma_1$ )

$$\sigma_1 = 20 \text{ N/mm}^2$$

Pressure of water inside the water main,

$$p = \rho \times g \times h = wh = 9810 \times 100 \text{ N/m}^2$$

Here  $\sigma_1$  is in N/mm<sup>2</sup>, hence pressure ( $p$ ) should also be N/mm<sup>2</sup>. The value of  $p$  in N/mm<sup>2</sup> is given as

$$p = \frac{9810 \times 100}{1000^2 \text{ mm}^2} \text{ N/mm}^2 \quad (\because 1 \text{ m} = 1000 \text{ mm})$$

$$= 0.981 \text{ N/mm}^2$$

Let  $t =$  Thickness of the metal required.

Using equation (17.1),

$$\sigma_1 = \frac{p \times d}{2 \times t} \quad (\text{Here 'd' is in cm hence 't' will also be in cm})$$

$$t = \frac{p \times d}{2 \times \sigma_1} = \frac{0.981 \times 80}{2 \times 20} = 2 \text{ cm. Ans.}$$

## 17.6. EFFICIENCY OF A JOINT

The cylindrical shells such as boilers are having two types of joints namely longitudinal joint and circumferential joint. In case of a joint, holes are made in the material of the shell for the rivets. Due to the holes, the area offering resistance decreases. Due to the decrease in area, the stress (which is the equal to the force divided by the area) developed in the material of the shell will be more.

Hence in case of rivetted shell the circumferential and longitudinal stresses are greater than what are given by equations (17.1) and (17.2). If the efficiency of a longitudinal joint and circumferential joint are given then the circumferential and longitudinal stresses are obtained as :

Let  $\eta_l =$  Efficiency of a longitudinal joint, and

$\eta_c =$  Efficiency of the circumferential joint.

Then the circumferential stress ( $\sigma_1$ ) is given as

$$\sigma_1 = \frac{p \times d}{2t \times \eta_l} \quad \dots(17.3)$$

and the longitudinal stress ( $\sigma_2$ ) is given as

$$\sigma_2 = \frac{p \times d}{4t \times \eta_c} \quad \dots(17.4)$$

**Note.** (i) In longitudinal joint, the circumferential stress is developed whereas in circumferential joint, the longitudinal stress is developed.

(ii) Efficiency of a joint means the efficiency of a longitudinal joint.

(iii) If efficiencies of a joint are given, the thickness of the thin shell is determined from equation (17.3).

**Problem 17.6.** A boiler is subjected to an internal steam pressure of 2 N/mm<sup>2</sup>. The thickness of boiler plate is 2.6 cm and permissible tensile stress is 120 N/mm<sup>2</sup>. Find out the maximum diameter, when efficiency of longitudinal joint is 90% and that of circumferential joint is 40%. (AMIE, 1976)

**Sol.** Given :

Internal steam pressure,  $p = 2$  N/mm<sup>2</sup>

Thickness of boiler plates,  $t = 2.0$  cm

Permissible tensile stress = 120 N/mm<sup>2</sup>

In case of a joints, the permissible stress may be circumferential stress or longitudinal stress.

Efficiency of longitudinal joint,  $\eta_l = 90\% = 0.90$

Efficiency of circumferential joint,  $\eta_c = 40\% = 0.40$ .

Max. diameter for circumferential stress is given by equation (17.3).

$\therefore$  Using equation (17.3),

$$\sigma_1 = \frac{p \times d}{2 \times \eta_l \times t}$$

where  $\sigma_1 =$  Given permissible stress = 120 N/mm<sup>2</sup>

$$\therefore 120 = \frac{2 \times d}{2 \times 0.90 \times 2.0} \quad (\text{Here } p \text{ and } \sigma_1 \text{ are in same units. Thickness is in cm hence 'd' will be in cm})$$

$$\therefore d = \frac{120 \times 2 \times 0.9 \times 2.0}{2} = 216.0 \text{ cm.} \quad \dots(i)$$

Max. diameter for longitudinal stress is given by equation (17.4).

$\therefore$  Using equation (17.4),

$$\sigma_2 = \frac{p \times d}{4 \times \eta_c \times t}$$

where  $\sigma_2 =$  Given permissible stress = 120 N/mm<sup>2</sup>.

$$\therefore 120 = \frac{2 \times d}{4 \times 0.4 \times 2.0}$$

$$\therefore d = \frac{120 \times 4 \times 0.4 \times 2.0}{2} = 192 \text{ cm.} \quad \dots(ii)$$

The longitudinal or circumferential stresses induced in the material are directly proportional to diameter ( $d$ ). Hence the stress induced will be less if the value of  $d$  is less. Hence take the minimum value of  $d$  calculated from equations (i) and (ii).

Maximum diameter of the boiler is equal to the minimum\* value of diameter given by equation (i) and (ii).

Hence maximum diameter,  $d = 192 \text{ cm}$ . **Ans.**

(\*Please note that if  $d$  is taken as equal to 216.0 cm, the longitudinal stress ( $\sigma_2$ ) will be more than the given permissible value as shown below :

$$\sigma_2 = \frac{p \times d}{4 \times \eta_c \times t} = \frac{2 \times 216}{4 \times 0.4 \times 2.0} = 135 \text{ N/mm}^2.$$

**Problem 17.7.** A boiler shell is to be made of 15 mm thick plate having a limiting tensile stress of 120 N/mm<sup>2</sup>. If the efficiencies of the longitudinal and circumferential joints are 70% and 30% respectively determine :

(i) The maximum permissible diameter of the shell for an internal pressure of 2 N/mm<sup>2</sup>,

and

(ii) Permissible intensity of internal pressure when the shell diameter is 1.5 m.

(AMIE, Winter 1981)

**Sol. Given :**

Thickness of boiler shell,  $t = 15 \text{ mm}$

Limiting tensile stress = 120 N/mm<sup>2</sup>

Limiting tensile stress may be circumferential stress or longitudinal stress.

Efficiency of longitudinal joint,  $\eta_l = 70\% = 0.70$

Efficiency of circumferential joint,  $\eta_c = 30\% = 0.30$ .

(i) Maximum Permissible diameter for an internal pressure,

$$p = 2 \text{ N/mm}^2.$$

The boiler shell should be designed for the limiting tensile stress of 120 N/mm<sup>2</sup>. First consider the limiting tensile stress as circumferential stress and then as longitudinal stress. The minimum diameter of the two case will satisfy the condition.

(a) Taking limiting tensile stress = Circumferential stress

$$\sigma_1 = 120 \text{ N/mm}^2.$$

$\therefore$

$$\sigma_1 = 120 \text{ N/mm}^2$$

But  $\sigma_1$  is also given by equation (17.3) as

$$\sigma_1 = \frac{p \times d}{2 \times \eta_l \times t}$$

$\therefore$

$$120 = \frac{2 \times d}{2 \times 0.7 \times 15} \quad (\text{Here } t \text{ is in mm hence 'd' will be in mm})$$

$\therefore$

$$d = \frac{120 \times 2 \times 0.7 \times 15}{2} = 1260 \text{ mm} \quad \dots(i)$$

(b) Taking limiting tensile stress = Longitudinal stress

$$(\sigma_2) = 120 \text{ N/mm}^2.$$

$\therefore$

$$\sigma_2 = 120 \text{ N/mm}^2$$

Using equation (17.4),

$$\sigma_2 = \frac{p \times d}{4 \times \eta_c \times t}$$

or

$$120 = \frac{2 \times d}{4 \times 0.30 \times 15}$$

$$\therefore d = \frac{120 \times 4 \times 0.3 \times 15}{2} = 1080 \text{ mm} \quad \dots(ii)$$

Thus the maximum diameter of the shell, in order both the conditions may be satisfied = 1080 mm. **Ans.**

(ii) Permissible intensity of internal pressure when the shell diameter is 1.5 m.

or

$$d = 1.5 \text{ m} = 1500 \text{ mm}.$$

(a) Taking limiting tensile stress = Circumferential stress ( $\sigma_1$ )  
= 120 N/mm<sup>2</sup>

Using equation (17.3),

$$\sigma_1 = \frac{p \times d}{2 \times \eta_l \times t}$$

or

$$120 = \frac{p \times 1500}{2 \times 0.7 \times 15} \quad (\text{Here } \sigma_1 \text{ is in N/mm}^2 \text{ hence 'p' will be in N/mm}^2)$$

$\therefore$

$$p = \frac{120 \times 2 \times 0.7 \times 15}{1500} = 1.68 \text{ N/mm}^2 \quad \dots(i)$$

(b) Taking limiting tensile stress = Longitudinal stress ( $\sigma_2$ )  
= 120 N/mm<sup>2</sup>

Using equation (17.4),

$$\sigma_2 = \frac{p \times d}{4 \times \eta_c \times t}$$

$$120 = \frac{p \times 1500}{4 \times 0.30 \times 15}$$

$\therefore$

$$p = \frac{120 \times 4 \times 0.30 \times 15}{1500} = 1.44 \text{ N/mm}^2 \quad \dots(ii)$$

Hence in order both the conditions may be satisfied the maximum permissible internal pressure is equal to the minimum\* value of pressure given by (i) and (ii).

$\therefore$  Maximum permissible internal pressure = 1.44 N/mm<sup>2</sup>

(\*If  $p$  is taken equal to 1.68 N/mm<sup>2</sup>, then longitudinal stress ( $\sigma_2$ ) will be,

$$\sigma_2 = \frac{p \times d}{4 \times \eta_c \times t} = \frac{1.68 \times 1500}{4 \times 0.30 \times 15} = 140 \text{ N/mm}^2.$$

This value is more than the given limiting tensile stress.

**Problem 17.8.** A cylinder of thickness 1.5 cm, has to withstand maximum internal pressure of 1.5 N/mm<sup>2</sup>. If the ultimate tensile stress in the material of the cylinder is 300 N/mm<sup>2</sup>, factor of safety 3.0 and joint efficiency 80%, determine the diameter of the cylinder.

**Sol. Given :**

Thickness of cylinder,  $t = 1.5 \text{ cm}$

Internal pressure,  $p = 1.5 \text{ N/mm}^2$

Ultimate tensile stress = 300 N/mm<sup>2</sup>

Factor of safety = 3.0

$\therefore$  Working stress or  $\sigma_1$

$$= \frac{\text{Ultimate tensile stress}}{\text{Factor of safety}} = \frac{300}{3} = 100 \text{ N/mm}^2$$

Joint efficiency,  $\eta = 80\% = 0.80$

Joint efficiency means the efficiency of longitudinal joint (or  $\eta_l$ ),

$$\therefore \eta_l = 0.80.$$

The stress corresponding to longitudinal joint is given by equation (17.3).

Using equation (17.3),

$$\sigma_1 = \frac{p \times d}{2 \times \eta_l \times t}$$

$$100 = \frac{1.5 \times d}{2 \times 0.80 \times 1.5}$$

$$\therefore d = \frac{100 \times 2 \times 0.80 \times 1.5}{1.5} = 160 \text{ cm} = 1.6 \text{ m. Ans.}$$

### 17.7. EFFECT OF INTERNAL PRESSURE ON THE DIMENSIONS OF A THIN CYLINDRICAL SHELL

When a fluid having internal pressure ( $p$ ) is stored in a thin cylindrical shell, due to internal pressure of the fluid the stresses set up at any point of the material of the shell are :

(i) Hoop or circumferential stress ( $\sigma_1$ ), acting on longitudinal section.

(ii) Longitudinal stress ( $\sigma_2$ ) acting on the circumferential section.

These stresses are principal stresses, as they are acting on principal planes. The stress in the third principal plane is zero as the thickness ( $t$ ) of the cylinder is very small. Actually the stress in the third principal plane is radial stress which is very small for thin cylinders and can be neglected.

Let  $p$  = Internal pressure of fluid

$L$  = Length of cylindrical shell

$d$  = Diameter of the cylindrical shell

$t$  = Thickness of the cylindrical shell

$E$  = Modulus of Elasticity for the material of the shell

$\sigma_1$  = Hoop stress in the material

$\sigma_2$  = Longitudinal stress in the material

$\mu$  = Poisson's ratio

$\delta d$  = Change in diameter due to stresses set up in the material

$\delta L$  = Change in length

$\delta V$  = Change in volume.

The values of  $\sigma_1$  and  $\sigma_2$  are given by equations (17.1) and (17.2) as

$$\sigma_1 = \frac{pd}{2t}$$

$$\sigma_2 = \frac{p \times d}{4t}$$

Let  $e_1$  = Circumferential strain,

$e_2$  = Longitudinal strain.

Then circumferential strain,

$$e_1 = \frac{\sigma_1}{E} - \frac{\mu\sigma_2}{E} \quad \dots(17.5)$$

$$\begin{aligned} &= \frac{pd}{2tE} - \frac{\mu pd}{4tE} \quad \left( \because \sigma_1 = \frac{pd}{2t} \text{ and } \sigma_2 = \frac{pd}{4t} \right) \\ &= \frac{pd}{2tE} \left[ 1 - \frac{\mu}{2} \right] \quad \dots(17.6) \end{aligned}$$

and longitudinal strain,

$$e_2 = \frac{\sigma_2}{E} - \frac{\mu\sigma_1}{E} \quad \dots(17.7)$$

$$\begin{aligned} &= \frac{pd}{4tE} - \frac{\mu pd}{2tE} \quad \text{(substituting values of } \sigma_1 \text{ and } \sigma_2) \\ &= \frac{pd}{2tE} \left( \frac{1}{2} - \mu \right) \quad \dots(17.8) \end{aligned}$$

But circumferential strain is also given as,

$$\begin{aligned} e_1 &= \frac{\text{Change in circumference due to pressure}}{\text{Original circumference}} \\ &= \frac{\text{Final circumference} - \text{Original circumference}}{\text{Original circumference}} \\ &= \frac{\pi(d + \delta d) - \pi d}{\pi d} \\ &= \frac{\pi d + \pi \delta d - \pi d}{\pi d} = \frac{\pi \delta d}{\pi d} \\ &= \frac{\delta d}{d} \quad \left( \text{or} = \frac{\text{Change in diameter}}{\text{Original diameter}} \right) \quad \dots(17.9) \end{aligned}$$

Equating the two values of  $e_1$  given by equations (17.6) and (17.9), we get

$$\frac{\delta d}{d} = \frac{pd}{2tE} \left[ 1 - \frac{\mu}{2} \right] \quad \dots(17.10)$$

$\therefore$  Change in diameter,

$$\delta d = \frac{pd^2}{2tE} \left( 1 - \frac{\mu}{2} \right) \quad \dots(17.11)$$

Similarly longitudinal strain is also given as,

$$\begin{aligned} e_2 &= \frac{\text{Change in length due to pressure}}{\text{Original length}} \\ &= \frac{\delta L}{L} \quad \dots(17.12) \end{aligned}$$

Equating the two values of  $e_2$  given by equations (17.8) and (17.12).

$$\therefore \frac{\delta L}{L} = \frac{pd}{2tE} \left( \frac{1}{2} - \mu \right) \quad \dots(17.13)$$

$\therefore$  Change in length,

$$\delta L = \frac{p \times d \times L}{2tE} \left( \frac{1}{2} - \mu \right) \quad \dots(17.14)$$

**Volumetric strains.** It is defined as change in volume divided by original volume.

$$\therefore \text{Volumetric strain} = \frac{\delta V}{V}$$

$$\begin{aligned} \text{But change in volume } (\delta V) &= \text{Final volume} - \text{Original volume} \\ \text{Original volume } (V) &= \text{Area of cylindrical shell} \times \text{Length} \\ &= \frac{\pi}{4} d^2 \times L \end{aligned}$$

$$\begin{aligned} \text{Final volume} &= (\text{Final area of cross-section}) \times \text{Final length} \\ &= \frac{\pi}{4} [d + \delta d]^2 \times [L + \delta L] \\ &= \frac{\pi}{4} [d^2 + (\delta d)^2 + 2d \delta d] \times [L + \delta L] \\ &= \frac{\pi}{4} [d^2 L + (\delta d)^2 L + 2d L \delta d + \delta L d^2 + \delta L (\delta d)^2 + 2d \delta d \delta L] \end{aligned}$$

Neglecting the smaller quantities such as  $(\delta d)^2 L$ ,  $\delta L (\delta d)^2$  and  $2d \delta d \delta L$ , we get

$$\text{Final volume} = \frac{\pi}{4} [d^2 L + 2d L \delta d + \delta L d^2]$$

$$\begin{aligned} \therefore \text{Change in volume } (\delta V) &= \frac{\pi}{4} [d^2 L + 2d L \delta d + \delta L d^2] - \frac{\pi}{4} d^2 \times L \\ &= \frac{\pi}{4} [2d L \delta d + \delta L d^2] \end{aligned}$$

$$\begin{aligned} \therefore \text{Volumetric strains} &= \frac{\delta V}{V} = \frac{\frac{\pi}{4} [2d L \delta d + \delta L d^2]}{\frac{\pi}{4} d^2 \times L} \\ &= \frac{2\delta d}{d} + \frac{\delta L}{L} \quad \dots(17.15) \end{aligned}$$

$$= 2e_1 + e_2 \quad \left( \because \frac{\delta d}{d} = e_1, \frac{\delta L}{L} = e_2 \right) \quad \dots(17.16)$$

$$= 2 \times \frac{pd}{2Et} \left[ 1 - \frac{\mu}{2} \right] + \frac{pd}{2Et} \left( \frac{1}{2} - \mu \right)$$

(Substituting the values of  $e_1$  and  $e_2$ )

$$\begin{aligned} &= \frac{pd}{2Et} \left( 2 - \frac{2\mu}{2} + \frac{1}{2} - \mu \right) \\ &= \frac{pd}{2Et} \left( 2 + \frac{1}{2} - \mu - \mu \right) \\ &= \frac{pd}{2Et} \left( \frac{5}{2} - 2\mu \right) \quad \dots(17.17) \end{aligned}$$

$$\text{Also change in volume } (\delta V) = V(2e_1 + e_2) \quad \dots(17.18)$$

**Problem 17.9.** Calculate : (i) the change in diameter, (ii) change in length and (iii) change in volume of a thin cylindrical shell 100 cm diameter, 1 cm thick and 5 m long when subjected to internal pressure of 3 N/mm<sup>2</sup>. Take the value of  $E = 2 \times 10^5$  N/mm<sup>2</sup> and Poisson's ratio,  $\mu = 0.3$ .

**Sol.** Given :

Diameter of shell,  $d = 100$  cm

Thickness of shell,  $t = 1$  cm

Length of shell,  $L = 5$  m =  $5 \times 100 = 500$  cm

Internal pressure,  $p = 3$  N/mm<sup>2</sup>

Young's modulus,  $E = 2 \times 10^5$  N/mm<sup>2</sup>

Poisson's ratio,  $\mu = 0.30$

(i) Change in diameter ( $\delta d$ ) is given by equation (17.11) as

$$\begin{aligned} \delta d &= \frac{pd^2}{2tE} \left[ 1 - \frac{\mu}{2} \right] \\ &= \frac{3 \times 100^2}{2 \times 1 \times 2 \times 10^5} \left[ 1 - \frac{1}{2} \times 0.30 \right] \\ &= \frac{3}{40} [1 - 0.15] = \mathbf{0.06375 \text{ cm.}} \quad \text{Ans.} \end{aligned}$$

(ii) Change in length ( $\delta L$ ) is given by equation (17.14) as

$$\begin{aligned} \delta L &= \frac{pdL}{2tE} \left[ \frac{1}{2} - \mu \right] \\ &= \frac{3 \times 100 \times 500}{2 \times 1 \times 2 \times 10^5} \left[ \frac{1}{2} - 0.30 \right] \\ &= \frac{15}{40} \times 0.20 = \mathbf{0.075 \text{ cm.}} \quad \text{Ans.} \end{aligned}$$

(iii) Change in volume ( $\delta V$ ) is given by equation (17.18) as

$$\begin{aligned} \delta V &= V [2e_1 + e_2] \\ &= V \left[ 2 \frac{\delta d}{d} + \frac{\delta L}{L} \right] \quad \left( \because e_1 = \frac{\delta d}{d}, e_2 = \frac{\delta L}{L} \right) \end{aligned}$$

Substituting the values of  $\delta d$ ,  $\delta L$ ,  $d$  and  $L$ , we get

$$\begin{aligned} \delta V &= V \left[ 2 \times \frac{0.06375}{100} + \frac{0.075}{500} \right] \\ &= V [0.001275 + 0.00015] = \mathbf{0.001425 V.} \end{aligned}$$

But

$$\begin{aligned} V &= \text{Original volume} = \frac{\pi}{4} d^2 L \\ &= \frac{\pi}{4} \times 100^2 \times 500 \text{ cm}^3 = 3926990.817 \text{ cm}^3 \\ \therefore \delta V &= 0.001425 \times 3926990.817 = \mathbf{5595.96 \text{ cm}^3.} \quad \text{Ans.} \end{aligned}$$

**Problem 17.10.** A cylindrical thin drum 80 cm in diameter and 3 m long has a shell thickness of 1 cm. If the drum is subjected to an internal pressure of 2.5 N/mm<sup>2</sup>, determine (i) change in diameter, (ii) change in length and (iii) change in volume.

Take  $E = 2 \times 10^5$  N/mm<sup>2</sup> ; Poisson's ratio = 0.25. (Annamalai University 1990)

**Sol.** Given :

Diameter of drum,  $d = 80$  cm

Length of drum,  $L = 3$  m =  $3 \times 100 = 300$  cm

Thickness of drum,  $t = 1$  cm

Internal pressure,  $p = 2.5$  N/mm<sup>2</sup>

Young's modulus,  $E = 2 \times 10^5$  N/mm<sup>2</sup>

Poisson's ratio,  $\mu = 0.25$



(i) Change in diameter ( $\delta d$ ) is given by equation (17.11) as

$$\begin{aligned}\delta d &= \frac{pd^2}{2tE} \left(1 - \frac{1}{2} \times \mu\right) \\ &= \frac{2.5 \times 80^2}{2 \times 1 \times 2 \times 10^5} \left[1 - \frac{1}{2} \times 0.25\right] \\ &= 0.04 [1 - 0.125] = 0.035 \text{ cm. Ans.}\end{aligned}$$

(ii) Change in length ( $\delta L$ ) is given by equation (17.14) as

$$\begin{aligned}\delta L &= \frac{pdL}{2tE} \left[\frac{1}{2} - \mu\right] \\ &= \frac{2.5 \times 80 \times 300}{2 \times 1 \times 2 \times 10^5} \left[\frac{1}{2} - 0.25\right] = 0.0357 \text{ cm. Ans.}\end{aligned}$$

(iii) Using equation (17.15) for volumetric strain  $\left(\frac{\delta V}{V}\right)$ , we have

$$\begin{aligned}\frac{\delta V}{V} &= 2 \frac{\delta d}{d} + \frac{\delta L}{L} \\ &= 2 \times \frac{0.035}{80} + \frac{0.0375}{300} \quad \left(\because \begin{array}{l} \delta d = 0.035, \quad \delta L = 0.0375 \\ d = 80, \quad L = 300 \end{array}\right) \\ &= 0.000875 + 0.000125 = 0.001 \\ \delta V &= 0.001 \times V\end{aligned}$$

$$\text{where volume } V = \frac{\pi}{4} d^2 \times L = \frac{\pi}{4} \times 80^2 \times 300 = 1507964.473 \text{ cm}^3$$

$\therefore$  Change in volume,  $\delta V = 0.001 \times 1507964.473 = 1507.96 \text{ cm}^3$ . Ans.

**Problem 17.11.** A cylindrical shell 90 cm long 20 cm internal diameter having thickness of metal as 8 mm is filled with fluid at atmospheric pressure. If an additional 20 cm<sup>3</sup> of fluid is pumped into the cylinder, find (i) the pressure exerted by the fluid on the cylinder and (ii) the hoop stress induced. Take  $E = 2 \times 10^5 \text{ N/mm}^2$  and  $\mu = 0.3$ . (AMIE, Summer 1977)

**Sol.** Given :

Length of cylinder,	$L = 90 \text{ cm}$
Diameter of cylinder,	$d = 20 \text{ cm}$
Thickness of cylinder,	$t = 8 \text{ mm} = 0.8 \text{ cm}$
Volume of additional fluid	$= 20 \text{ cm}^3$

$$\begin{aligned}\text{Volume of cylinder, } V &= \frac{\pi}{4} d^2 \times L = \frac{\pi}{4} \times 20^2 \times 90 \\ &= 28274.33 \text{ cm}^3\end{aligned}$$

$$\begin{aligned}\text{Increase in volume, } \delta V &= \text{Volume of additional fluid} \\ &= 20 \text{ cm}^3\end{aligned}$$

(i) Let  $p$  = Pressure exerted by fluid on the cylinder

$$E = 2 \times 10^5 \text{ N/mm}^2$$

$$\mu = 0.3.$$

Now using equation (17.16), volumetric strain is given as

$$\frac{\delta V}{V} = 2e_1 + e_2$$

$$\text{or } \frac{20}{28274.33} = 2e_1 + e_2 \quad \dots(i)$$

But  $e_1$  and  $e_2$  are circumferential and longitudinal strains and are given by equation (17.6) and (17.8) respectively as

$$e_1 = \frac{pd}{2Et} \left[1 - \frac{1}{2} \times \mu\right]$$

$$\text{and } e_2 = \frac{pd}{2tE} \left(\frac{1}{2} - \mu\right).$$

Substituting these values in equation (i), we get

$$\begin{aligned}\frac{20}{28274.33} &= \frac{2pd}{2Et} \left[1 - \frac{1}{2} \times \mu\right] + \frac{pd}{2tE} \left[\frac{1}{2} - \mu\right] \\ &= \frac{2p \times 20}{2 \times 2 \times 10^5 \times 0.8} \left[1 - \frac{1}{2} \times 0.3\right] + \frac{p \times 20}{0.8 \times 2 \times 10^5} \left[\frac{1}{2} - 0.3\right]\end{aligned}$$

$$\begin{aligned}\text{or } 0.000707 &= \frac{p}{8000} \times 0.85 + \frac{p}{8000} \times 0.20 = \frac{1.05p}{8000} \\ \therefore p &= \frac{0.000707 \times 8000}{1.05} = 5.386 \text{ N/mm}^2. \text{ Ans.}\end{aligned}$$

(ii) Hoop stress ( $\sigma_1$ ) is given by equation (17.1) as

$$\sigma_1 = \frac{pd}{2t} = \frac{5.386 \times 20}{2 \times 0.8} = 67.33 \text{ N/mm}^2. \text{ Ans.}$$

**Problem 17.12.** A cylindrical vessel whose ends are closed by means of rigid flange plates, is made of steel plate 3 mm thick. The length and the internal diameter of the vessel are 50 cm and 25 cm respectively. Determine the longitudinal and hoop stresses in the cylindrical shell due to an internal fluid pressure of 3 N/mm<sup>2</sup>. Also calculate the increase in length, diameter and volume of the vessel. Take  $E = 2 \times 10^5 \text{ N/mm}^2$  and  $\mu = 0.3$ . (AMIE, Winter 1984)

**Sol.** Given :

Thickness,	$t = 3 \text{ mm} = 0.3 \text{ cm}$
Length of the cylindrical vessel,	$L = 50 \text{ cm}$
Internal diameter,	$d = 25 \text{ cm}$
Internal fluid pressure,	$p = 3 \text{ N/mm}^2$
Young's modulus,	$E = 2 \times 10^5 \text{ N/mm}^2$
Poisson's ratio,	$\mu = 0.3$

Let  $\sigma_1$  = Hoop stress and

$\sigma_2$  = Longitudinal stress.

Using equation (17.1) for hoop stress,

$$\sigma_1 = \frac{p \times d}{2t} = \frac{3 \times 25}{2 \times 0.3} = 125 \text{ N/mm}^2. \text{ Ans.}$$

Using equation (17.2) for longitudinal stress,

$$\sigma_2 = \frac{p \times d}{4t} = \frac{3 \times 25}{4 \times 0.3} = 62.5 \text{ N/mm}^2. \text{ Ans.}$$

Using equation (17.5) for circumferential strain,

$$\begin{aligned} e_1 &= \frac{\sigma_1}{E} - \frac{\mu \times \sigma_2}{E} \\ &= \frac{1}{E} [\sigma_1 - \mu \times \sigma_2] \\ &= \frac{1}{2 \times 10^5} [125 - 62.5 \times 0.3] \quad (\because \mu = 0.3, \sigma_1 = 125 \text{ and } \sigma_2 = 62.5) \\ &= \frac{1}{2 \times 10^5} (125 - 18.75) = \frac{106.25}{2 \times 10^5} \\ &= 53.125 \times 10^{-5}. \end{aligned}$$

But circumferential strain is also given by equation (17.9) as

$$e_1 = \frac{\delta d}{d}$$

Equating the two values of circumferential strain  $e_1$ , we get

$$\begin{aligned} \frac{\delta d}{d} &= 53.125 \times 10^{-5} \\ \therefore \delta d &= 53.125 \times 10^{-5} \times d = 53.125 \times 10^{-5} \times 25 = 0.0133 \text{ cm} \end{aligned}$$

$\therefore$  Increase in diameter,  $\delta d = 0.0133 \text{ cm}$ . Ans.

Longitudinal strain is given by equation (17.7) as

$$\begin{aligned} e_2 &= \frac{\delta L}{L} = \frac{\sigma_2}{E} - \frac{\mu \times \sigma_1}{E} \\ &= \frac{1}{E} [\sigma_2 - \mu \times \sigma_1] \\ &= \frac{1}{2 \times 10^5} [62.5 - 125 \times 0.3] = \frac{1}{2 \times 10^5} [62.5 - 37.5] \\ &= \frac{2.5}{2 \times 10^5} = 12.5 \times 10^{-5} \end{aligned}$$

$\therefore$  Increase in length,  $\delta L = 12.5 \times 10^{-5} \times L$

$$= 12.5 \times 10^{-5} \times 50 = 0.00625 \text{ cm. Ans.}$$

Volumetric strain is given by equation (17.16), as

$$\begin{aligned} \frac{\delta V}{V} &= 2 \frac{\delta d}{d} + \frac{\delta l}{l} \\ &= 2e_1 + e_2 = 2 \times 53.125 \times 10^{-5} + 12.5 \times 10^{-5} \\ &= 106.25 \times 10^{-5} + 12.5 \times 10^{-5} = 118.75 \times 10^{-5} \end{aligned}$$

$\therefore$  Increase in volume,

$$\begin{aligned} \delta V &= 118.75 \times 10^{-5} \times V \\ &= 118.75 \times 10^{-5} \times \frac{\pi}{4} \times 25^2 \times 50 \quad \left( \because \text{volume} = \frac{\pi}{4} d^2 \times L \right) \\ &= 29.13 \text{ cm}^3. \text{ Ans.} \end{aligned}$$

**Problem 17.13.** A cylindrical vessel is 1.5 m diameter and 4 m long is closed at ends by rigid plates. It is subjected to an internal pressure of 3 N/mm<sup>2</sup>. If the maximum principal stress is not to exceed 150 N/mm<sup>2</sup>, find the thickness of the shell. Assume  $E = 2 \times 10^5 \text{ N/mm}^2$  and Poisson's ratio = 0.25. Find the changes in diameter, length and volume of the shell.

(AMIE, Winter 1988)

Sol. Given :

Dia.,  $d = 1.5 \text{ m} = 1500 \text{ mm}$

Length,  $L = 4 \text{ m} = 4000 \text{ mm}$

Internal pressure,  $p = 3 \text{ N/mm}^2$

Max. principal stress = 150 N/mm<sup>2</sup>

Max. principal stress means the circumferential stress

$\therefore$  Circumferential stress,  $\sigma_1 = 150 \text{ N/mm}^2$

Value of  $E = 2 \times 10^5 \text{ N/mm}^2$ .

Poisson's ratio,  $\mu = 0.25$

Let  $t$  = thickness of the shell,

$\delta d$  = change in diameter,

$\delta L$  = change in length, and

$\delta V$  = change in volume.

(i) Using equation (17.1),

$$\sigma_1 = \frac{p \times d}{2t}$$

$$\therefore t = \frac{p \times d}{2 \times \sigma_1} = \frac{3 \times 1500}{2 \times 150}$$

(Here  $p$  and  $\sigma_1$  are in same units, 'd'

is in mm hence 't' will be in mm)

$$= 15 \text{ mm. Ans.}$$

(ii) Using equation (17.11),

$$\delta d = \frac{pd^2}{2t \times E} \left( 1 - \frac{1}{2} \times \mu \right)$$

$$= \frac{3 \times 1500^2}{2 \times 15 \times 2 \times 10^5} \left( 1 - \frac{1}{2} \times 0.25 \right) = 0.984 \text{ mm. Ans.}$$

(iii) Using equation (17.14),

$$\delta L = \frac{p \times d \times L}{2t \times E} \left( \frac{1}{2} - \mu \right)$$

$$= \frac{3 \times 1500 \times 4000}{2 \times 15 \times 2 \times 10^5} \left( \frac{1}{2} - 0.25 \right)$$

$$= 0.75 \text{ mm. Ans.}$$

(iv) Using equation (17.17),

$$\frac{\delta V}{V} = \frac{p \times d}{2E \times t} \left( \frac{5}{2} - 2 \times \mu \right)$$

$$= \frac{3 \times 1500}{2 \times 2 \times 10^5 \times 15} \left( \frac{5}{2} - 2 \times 0.25 \right) = \frac{3 \times 1500 \times 2}{4 \times 10^5 \times 15}$$

$\therefore$

$$\delta V = \frac{3}{2000} \times V = \frac{3}{2000} \times \left( \frac{\pi}{4} \times d^2 \times L \right)$$

$$= \frac{3}{2000} \times \left( \frac{\pi}{4} \times 1500^2 \times 4000 \right) = 10602875 \text{ mm}^3. \text{ Ans.}$$

**Problem 17.14.** A closed cylindrical vessel made of steel plates 4 mm thick with plane ends, carries fluid under a pressure of 3 N/mm<sup>2</sup>. The dia. of cylinder is 25 cm and length is 75 cm, calculate the longitudinal and hoop stresses in the cylinder wall and determine the change in diameter, length and volume of the cylinder. Take  $E = 2.1 \times 10^5$  N/mm<sup>2</sup> and  $\mu = 0.286$ . (AMIE, Summer 1990)

**Sol. Given :**

Thickness,	$t = 4$ mm
Fluid pressure,	$p = 3$ N/mm <sup>2</sup>
Diameter,	$d = 25$ cm = 250 mm
Length,	$L = 75$ cm = 750 mm
Value of	$E = 2.1 \times 10^5$ N/mm <sup>2</sup>
Poisson's ratio,	$\mu = 0.286$

Let  $\sigma_1$  = Hoop stress,  
 $\sigma_2$  = Longitudinal stress,  
 $\delta d$  = Change in diameter,  
 $\delta L$  = Change in length, and  
 $\delta V$  = Change in volume.

(i) Longitudinal stress is given by equation (17.2) as

$$\begin{aligned}\sigma_2 &= \frac{p \times d}{4 \times t} \\ &= \frac{3 \times 250}{4 \times 4} = 46.875 \text{ N/mm}^2. \text{ Ans.}\end{aligned}$$

(ii) Hoop stress is given by equation (17.1) as

$$\begin{aligned}\sigma_1 &= \frac{p \times d}{2 \times t} \\ &= \frac{3 \times 250}{2 \times 4} = 93.75 \text{ N/mm}^2. \text{ Ans.}\end{aligned}$$

(iii) The change in diameter is given by equation (17.11) as

$$\begin{aligned}\delta d &= \frac{p \times d^2}{2t \times E} \left(1 - \frac{1}{2} \times \mu\right) \\ &= \frac{3 \times 250^2}{2 \times 4 \times 2.1 \times 10^5} \left(1 - \frac{1}{2} \times 0.286\right) = 0.0956 \text{ mm. Ans.}\end{aligned}$$

(iv) The change in length is given by equation (17.14) as

$$\begin{aligned}\delta L &= \frac{p \times d \times L}{2E \times t} \left(\frac{1}{2} - \mu\right) \\ &= \frac{3 \times 250 \times 750}{2 \times 2.1 \times 10^5 \times 4} \left(\frac{1}{2} - 0.286\right) = 0.0716 \text{ mm. Ans.}\end{aligned}$$

(v) The change in volume is given by equation (17.17) as

$$\begin{aligned}\frac{\delta V}{V} &= \frac{p \times d}{2t \times E} \left(\frac{5}{2} - 2 \times \mu\right) \\ &= \frac{3 \times 250}{2 \times 4 \times 2.1 \times 10^5} \left(\frac{5}{2} - 2 \times 0.286\right)\end{aligned}$$

$$\begin{aligned}&= \frac{750}{16.8 \times 10^5} (2.5 - 0.572) = \frac{750 \times 1.928}{16.8 \times 10^5} \\ \therefore \delta V &= \frac{750 \times 1.928}{16.8 \times 10^5} \times V \\ &= \frac{750 \times 1.928}{16.8 \times 10^5} \times \left(\frac{\pi}{4} \times 250^2 \times 750\right) \\ &\quad \left(\because V = \frac{\pi}{4} d^2 \times L = \frac{\pi}{4} \times 250^2 \times 750\right) \\ &= 31680 \text{ mm}^3. \text{ Ans.}\end{aligned}$$

**Problem 17.15.** A cylindrical shell 3 metres long which is closed as the ends has an internal diameter of 1 m and a wall thickness of 15 mm. Calculate the circumferential and longitudinal stresses induced and also changes in the dimensions of the shell, if it is subjected to an internal pressure of 1.5 N/mm<sup>2</sup>. Take  $E = 2 \times 10^5$  N/mm<sup>2</sup> and  $\mu = 0.3$ .

(AMIE, Summer 1983 ; Annamalai University 1991)

**Sol. Given :**

Length of shell,	$L = 3$ m = 300 cm
Internal diameter,	$d = 1$ m = 100 cm
Wall thickness,	$t = 15$ mm = 1.5 cm
Internal pressure,	$p = 1.5$ N/mm <sup>2</sup>
Young's modulus,	$E = 2 \times 10^5$ N/mm <sup>2</sup>
Poisson's ratio,	$\mu = 0.3$

Let  $\sigma_1$  = Circumferential (or Hoop) stress, and  
 $\sigma_2$  = Longitudinal stress.

Using equation (17.1) for hoop stress,

$$\begin{aligned}\sigma_1 &= \frac{pd}{2t} \\ &= \frac{1.5 \times 100}{2 \times 1.5} = 50 \text{ N/mm}^2. \text{ Ans.}\end{aligned}$$

Using equation (17.2) for longitudinal stress,

$$\begin{aligned}\sigma_2 &= \frac{p \times d}{4t} \\ &= \frac{1.5 \times 100}{4 \times 1.5} = 25 \text{ N/mm}^2. \text{ Ans.}\end{aligned}$$

*Changes in the dimensions*

Using equation (17.11) for the change in diameter ( $\delta d$ ),

$$\begin{aligned}\delta d &= \frac{pd^2}{2tE} \left(1 - \frac{1}{2} \times \mu\right) \\ &= \frac{1.5 \times 100^2}{2 \times 1.5 \times 2 \times 10^5} \left(1 - \frac{1}{2} \times 0.3\right) \\ &= \frac{1}{4 \times 10^3} (1 - 0.15) = \frac{0.85}{4 \times 10^3} \\ &= 0.2125 \times 10^{-3} \text{ cm. Ans.}\end{aligned} \quad (\because \mu = 0.3)$$

Using equation (17.14) for change in length, we get

$$\begin{aligned}\delta L &= \frac{p \times d \times L}{2tE} \left( \frac{1}{2} - \mu \right) \\ &= \frac{1.5 \times 100 \times 300}{2 \times 1.5 \times 2 \times 10^8} \left( \frac{1}{2} - 0.3 \right) \\ &= \frac{10 \times 100 \times 300}{4 \times 10^6} \times 0.2 = \frac{0.06}{4} = 0.015 \text{ cm. Ans.}\end{aligned}$$

Using equation (17.17) for volumetric strain, we get

$$\begin{aligned}\frac{\delta V}{V} &= \frac{p \times d}{2Et} \left[ \frac{5}{2} - 2\mu \right] \\ &= \frac{5 \times 100}{2 \times 2 \times 10^5 \times 1.5} [2.5 - 2 \times 0.3] \quad (\because \mu = 0.3) \\ &= 0.25 \times 10^{-3} \times [2.5 - 0.6] \\ &= 0.25 \times 10^{-3} \times 1.9 = 0.475 \times 10^{-3}\end{aligned}$$

$\therefore$  Change in volume,  $\delta V = 0.475 \times 10^{-3} \times V$

where  $V$  = Original volume

$$= \frac{\pi}{4} d^2 \times L = \frac{\pi}{4} \times 100^2 \times 300 = 2356194.49 \text{ cm}^3.$$

$\therefore \delta V = 0.475 \times 10^{-3} \times 2356194.49 = 1119.19 \text{ cm}^3. \text{ Ans.}$

**Problem 17.16.** A thin cylindrical shell with following dimensions is filled with a liquid atmospheric pressure : Length = 1.2 m, external diameter = 20 cm, thickness of metal = 8 mm.

Find the value of the pressure exerted by the liquid on the walls of the cylinder and the hoop stress induced if an additional volume of 25 cm<sup>3</sup> of liquid is pumped into the cylinder. Take  $E = 2.1 \times 10^5 \text{ N/mm}^2$  and Poisson's ratio = 0.33. (AMIE, Summer 1989)

**Sol.** Given :

Length,  $L = 1.2 \text{ m} = 1200 \text{ mm}$

External dia.  $D = 20 \text{ cm} = 200 \text{ mm}$

Thickness,  $t = 8 \text{ mm}$

$\therefore$  Internal dia.,  $d = D - 2 \times t = 200 - 2 \times 8 = 184 \text{ mm}$

Additional volume,  $\delta V = 25 \text{ cm}^3 = 25 \times 10^3 \text{ mm}^3 = 25000 \text{ mm}^3$

Value of  $E = 2.1 \times 10^5 \text{ N/mm}^2$

Poisson's ratio,  $\mu = 0.33$

Let  $p$  = Pressure exerted, and

$\sigma_1$  = hoop stress produced.

Volume of liquid or inside volume of cylinder,

$$\begin{aligned}V &= \frac{\pi}{4} d^2 \times L \\ &= \frac{\pi}{4} \times 184^2 \times 1200 = 31908528 \text{ mm}^3\end{aligned}$$

(i) Using equation (17.17),

$$\frac{\delta V}{V} = \frac{p \times d}{2E \times t} \left( \frac{5}{2} - 2\mu \right)$$

$$\begin{aligned}\text{or } \frac{25000}{31908528} &= \frac{p \times 184}{2 \times 2.1 \times 10^5 \times 8} \left( \frac{5}{2} - 2 \times 0.33 \right) \\ \therefore p &= \frac{25000 \times 2 \times 2.1 \times 10^5 \times 8}{31908528 \times 184 \times (2.5 - 0.66)} = 7.77 \text{ N/mm}^2. \text{ Ans.}\end{aligned}$$

(ii) Using equation (17.1),

$$\sigma_1 = \frac{p \times d}{2t} = \frac{7.77 \times 184}{2 \times 8} = 89.42 \text{ N/mm}^2. \text{ Ans.}$$

**Problem 17.17.** A hollow cylindrical drum 600 mm in diameter and 3 m long, has a shell thickness of 10 mm. If the drum is subjected to an internal air pressure of 3 N/mm<sup>2</sup>, determine the increase in its volume. Take  $E = 2 \times 10^5 \text{ N/mm}^2$  and Poisson's ratio = 0.3 for the material. (AMIE, Winter 1986)

**Sol.** Given :

External diameter,  $D = 600 \text{ mm}$

Length of drum,  $L = 3 \text{ m} = 3000 \text{ mm}$

Thickness of drum,  $t = 10 \text{ mm}$

Internal pressure,  $p = 3 \text{ N/mm}^2$

Young's modulus,  $E = 2 \times 10^5 \text{ N/mm}^2$

Poisson's ratio,  $\mu = 0.3$

Internal dia.,  $d = D - 2 \times t = 600 - 2 \times 10 = 580 \text{ mm}$

Using equation (17.17),

$$\begin{aligned}\frac{\delta V}{V} &= \frac{p \times d}{2E \times t} \left( \frac{5}{2} - 2\mu \right) \\ &= \frac{3 \times 580}{2 \times 2 \times 10^5} \times 10 \left( \frac{5}{2} - 2 \times 0.3 \right) = 0.000435 \times 1.9 = 0.0008265 \\ \therefore \delta V &= 0.0008265 \times V \\ &= 0.0008265 \times \left( \frac{\pi}{4} \times d^2 \times L \right) = 0.0008265 \times \left( \frac{\pi}{4} \times 580^2 \times 3000 \right) \\ &= 792623000 \text{ mm}^3. \text{ Ans.}\end{aligned}$$

### 17.8. A THIN CYLINDRICAL VESSEL SUBJECTED TO INTERNAL FLUID PRESSURE AND A TORQUE

When a thin cylindrical vessel is subjected to internal fluid pressure ( $p$ ), the stresses set up in the material of the vessel are circumferential stress  $\sigma_1$  and longitudinal stress  $\sigma_2$ . These two stresses are tensile and are acting perpendicular to each other. If the cylindrical vessel is subjected to a torque, shear stresses will also be set up in the material of the vessel.

Hence at any point in the material of the cylindrical vessel, there will be two tensile stresses mutually perpendicular to each other accompanied by a shear stress. The major principal stress, the minor principal stress and maximum shear stress will be obtained as given in Art. 3.4.4 on page 106 and 108.

Let  $\sigma_1$  = Circumferential stress (tensile)

$\sigma_2$  = Longitudinal stress (tensile)

$\tau$  = Shear stress due to torque.

$$\text{The major principal stress} = \frac{\sigma_1 + \sigma_2}{2} + \sqrt{\left(\frac{\sigma_1 - \sigma_2}{2}\right)^2 + \tau^2} \quad \dots(17.19)$$

$$\text{Minor principal stress} = \frac{\sigma_1 + \sigma_2}{2} - \sqrt{\left(\frac{\sigma_1 - \sigma_2}{2}\right)^2 + \tau^2} \quad \dots(17.20)$$

$$\text{and maximum shear stress} = \frac{1}{2} [\text{Major principal stress} - \text{Minor principal stress}] \quad \dots(17.21)$$

**Problem 17.18.** A thin cylindrical tube 80 mm internal diameter and 5 mm thick, is closed at the ends and is subjected to an internal pressure of 6 N/mm<sup>2</sup>. A torque of 2009600 Nmm is also applied to the tube. Find the hoop stress, longitudinal stress, maximum and minimum principal stresses and the maximum shear stress. (AMIE, Summer 1984)

**Sol.** Given :

Internal diameter,  $d = 80$  mm

Thickness of tube,  $t = 5$  mm

Internal pressure,  $p = 6$  N/mm<sup>2</sup>

Torque applied,  $T = 2009600$  Nmm

Let  $\sigma_1 =$  Hoop stress and

$\sigma_2 =$  Longitudinal stress.

Using equation (17.1) for hoop stress,

$$\sigma_1 = \frac{p \times d}{2t} = \frac{6 \times 80}{2 \times 5} = 48 \text{ N/mm}^2. \quad \text{Ans.}$$

Using equation (17.2) for longitudinal stress,

$$\sigma_2 = \frac{p \times d}{4t} = \frac{6 \times 80}{4 \times 5} = 24 \text{ N/mm}^2. \quad \text{Ans.}$$

*Maximum and minimum principal stresses*

The stresses  $\sigma_1$  and  $\sigma_2$  are tensile stresses. But the cylindrical tube is also subjected to torque. Due to torque, shear stress will be produced in the tube. As the thickness of the wall of the tube is small, the shear stress is assumed to be uniform throughout the thickness.

Let  $\tau =$  Shear stress in the wall of the tube

$\therefore$  Shear force = Shear stress  $\times$  Area

$$= \tau \times (\pi d \times t) \quad (\because \text{Area} = \text{Circumference} \times \text{Thickness} = \pi d \times t)$$

$$= \tau \times \pi \times 80 \times 5$$

$$= 400\pi\tau$$

$$\text{and torque, } T = \text{Shear force} \times \frac{d}{2} = 400\pi \times \tau \times \frac{d}{2}$$

$$= 400\pi \times \tau \times \frac{80}{2} = 16000\pi \times \tau \text{ Nmm}$$

But torque applied = 2009600 Nmm (given)

$\therefore$  Equating the two values of the torque, we get

$$16000\pi \times \tau = 2009600$$

$$\therefore \tau = \frac{2009600}{16000\pi} = 40 \text{ N/mm}^2.$$

Hence the material of the tube is subjected to two tensile stresses (i.e.,  $\sigma_1 = 48$  N/mm<sup>2</sup> and  $\sigma_2 = 24$  N/mm<sup>2</sup>) accompanied by a shear stress ( $\tau = 40$  N/mm<sup>2</sup>).

$\therefore$  Maximum principal stress\* is given by equation (17.19) as

$$\begin{aligned} \text{Max. principal stress} &= \frac{\sigma_1 + \sigma_2}{2} + \sqrt{\left(\frac{\sigma_1 - \sigma_2}{2}\right)^2 + \tau^2} \\ &= \frac{48 + 24}{2} + \sqrt{\left(\frac{48 - 24}{2}\right)^2 + 40^2} \\ &= 36 + \sqrt{12^2 + 1600} \\ &= 36 + 41.76 = 77.7 \text{ N/mm}^2 \text{ (tensile)}. \quad \text{Ans.} \end{aligned}$$

Minimum principal stress is given by equation (17.20) as

$$\begin{aligned} \text{Min. principal stress} &= \frac{\sigma_1 + \sigma_2}{2} - \sqrt{\left(\frac{\sigma_1 - \sigma_2}{2}\right)^2 + \tau^2} \\ &= \frac{48 + 24}{2} - \sqrt{\left(\frac{48 - 24}{2}\right)^2 + 40^2} \\ &= 36 - 41.76 \\ &= -5.76 \text{ N/mm}^2 \text{ (compressive)}. \quad \text{Ans.} \end{aligned}$$

(- ve sign shows compressive stress)

Max. shear stress is given by equation (17.21) as

$$\begin{aligned} \therefore \text{Maximum shear stress} &= \frac{\text{Max. principal stress} - \text{Min. principal stress}}{2} \\ &= \frac{77.76 - (-5.76)}{2} = \frac{77.76 + 5.76}{2} = \frac{83.52}{2} \\ &= 41.76 \text{ N/mm}^2. \quad \text{Ans.} \end{aligned}$$

**Problem 17.19.** A copper cylinder, 90 cm long, 40 cm external diameter and wall thickness 6 mm has its both ends closed by rigid blank flanges. It is initially full of oil at atmospheric pressure. Calculate the additional volume of oil which must be pumped into it in order to raise the oil pressure to 5 N/mm<sup>2</sup> above atmospheric pressure. For copper assume  $E = 1.0 \times 10^5$  N/mm<sup>2</sup> and Poisson's ratio = 1/3. Take bulk modulus of oil as  $2.6 \times 10^3$  N/mm<sup>2</sup>. (AMIE, Winter 1983)

**Sol.** Given :

Length of cylinder,  $L = 90$  cm

External diameter,  $D = 40$  cm

Wall thickness,  $t = 6$  mm = 0.6 cm.

$\therefore$  Internal diameter,  $d = \text{External dia.} - 2 \times \text{Wall thickness}$   
 $= 40 - 2 \times 0.6 = 38.8$  cm.

Initial volume of oil,  $V =$  Internal volume of cylinder

$$= \frac{\pi}{4} \times d^2 \times L$$

\*See equation 3.15 on page 106.

$$= \frac{\pi}{4} \times 38.8 \times 90 = 106413 \text{ cm}^3$$

Increase in oil pressure,  $p = 5 \text{ N/mm}^2$ .

Young's modulus for copper,  $E = 1.0 \times 10^5 \text{ N/mm}^2$

Poisson's ratio,  $\mu = \frac{1}{3}$ .

\*Bulk modulus of oil,  $k = 2.6 \times 10^5 \text{ N/mm}^2$

Due to internal pressure of fluid inside the cylinder, there will be a change in the dimensions of the cylinder. Due to this, there will be a increase in the volume of the cylinder. Let us first calculate this increase in volume of the cylinder.

Let  $\delta V_1 = \text{Increase in volume of cylinder.}$

Then volumetric strain  $= \frac{\delta V_1}{V}$ .

But volumetric strain due to fluid pressure is given by equation (17.17), as

$$\frac{\delta V_1}{V} = \frac{pd}{2Et} \left( \frac{5}{2} - 2\mu \right) \quad (\text{Here } \delta V_1 = \text{Increase of volume instead of } \delta V)$$

$$= \frac{5 \times 38.8}{2 \times 1.0 \times 10^5 \times 0.6} \left( \frac{5}{2} - 2 \times \frac{1}{3} \right) \quad (\because \mu = \frac{1}{3})$$

$$= \frac{5 \times 38.8}{2 \times 10^5 \times 0.6} (2.5 - 0.667) = 0.00296.$$

$$\therefore \delta V_1 = 0.00296 \times V$$

$$= 0.00296 \times 106413 \quad (\because V = 106413 \text{ cm}^3)$$

$$= 314.98 \text{ cm}^3.$$

As bulk modulus of oil is given, then due to increase of fluid pressure on the oil, the original volume of oil will decrease. Let us find this decrease in volume of the oil.

Let  $\delta V_2 = \text{Decrease in volume of oil due to increase of pressure.}$

Bulk modulus is given as

$$k = \frac{\text{Increase in pressure of oil}}{\left( \frac{\text{Decrease in volume of oil}}{\text{Original volume of oil}} \right)} = \frac{p}{\left( \frac{\delta V_2}{V} \right)}$$

$$= \frac{p \times V}{\delta V_2}$$

$$\therefore \frac{\delta V_2}{V} = \frac{p}{k}$$

or  $\delta V_2 = \frac{p}{k} \times V$

$$= \frac{5}{2.6 \times 10^5} \times 106413 = 204.64 \text{ cm}^3.$$

\* Bulk modulus,  $k = \frac{\text{Increase of pressure}}{\left( \frac{\text{Decrease in volume}}{\text{Volume}} \right)} = \frac{dp}{\left( \frac{dV}{V} \right)}$ .

$\therefore$  Resultant additional space created in the cylinder

$$= \text{Increase in volume of cylinder} + \text{Decrease in volume of oil}$$

$$= \delta V_1 + \delta V_2$$

$$= 314.98 + 204.64 = 519.62 \text{ cm}^3.$$

$\therefore$  Additional quantity of oil which must be pumped in order to raise the oil pressure to  $5 \text{ N/mm}^2$

$$= 519.62 \text{ cm}^3. \text{ Ans.}$$

### 17.9. WIRE WINDING OF THIN CYLINDERS

We have seen in previous articles that hoop stress (or circumferential stress) is two times the longitudinal stress in a thin cylinder, when the cylinder is subjected to internal fluid pressure. Hence the failure of a thin cylinder will be due to hoop stress. Also the hoop stress which is tensile in nature (for a given internal diameter and thickness of a pipe) is directly proportional to the fluid pressure inside the cylinder. Hence the maximum fluid pressure inside the cylinder is limited corresponding to the condition that the hoop stress reaches the permissible value. In case of cylinders which have to carry high internal fluid pressures, some methods of reducing the hoop stresses have to be devised.

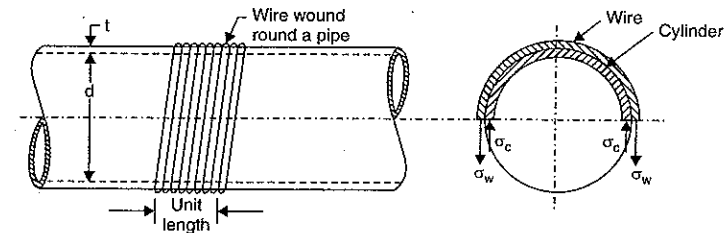

$\sigma_w = \text{Winding stress in wire (tensile)}$

$\sigma_c = \text{Compressive stress exerted by wire on cylinder}$

Fig. 17.5

One method is to wind strong steel wire under tension on the walls of the cylinders. The effect of the wire is to put the cylinder wall under an initial compressive stress. If now this cylinder is subjected to internal fluid pressure, the walls of the cylinder will be subjected to hoop tensile stress. The net effect of the initial compressive stress due to wire winding and those due to internal fluid pressure is to make resultant stress less. The resultant stress in the material of the cylinder will be the hoop (tensile) stress due to internal fluid pressure minus the initial compressive stress. Whereas the stress (tensile) in the wire will be equal to the sum of the tensile stress due to internal pressure in the cylinder and initial tensile winding stress.

If  $\sigma_w = \text{Initial winding stress in wire (tensile)}$

$\sigma_c = \text{Compressive circumferential stress exerted by wire on cylinder}$

The relation between  $\sigma_w$  and  $\sigma_c$  is obtained by considering a length 'L' of cylinder [Refer to Fig. 17.6 (a) and (b)].

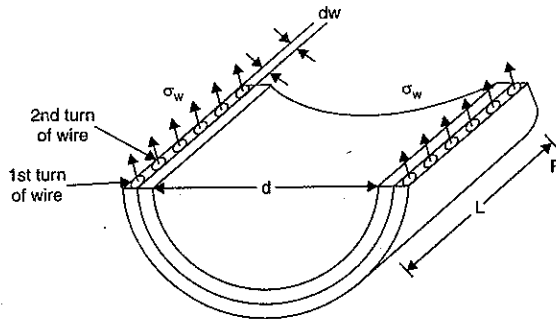

Initial tensile stress in wire =  $\sigma_w$

Initial tensile force in wire for length 'L' =  $n \times \left( 2 \times \frac{\pi}{4} dw^2 \right) \times \sigma_w$

where  $n$  = No. of turns in length  $L$

Fig. 17.6 (a)

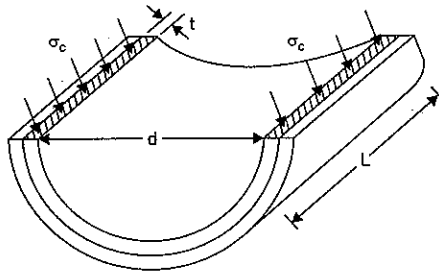

Initial compressive stress in cylinder =  $\sigma_c$

Initial compressive force in cylinder for length  $L = 2L \times t \times \sigma_c$

Fig. 17.6 (b)

Initial tensile force in wire for length  $L$  of cylinder

$$= n \times \left( 2 \times \frac{\pi}{4} dw^2 \right) \times \sigma_w$$

where  $n$  = No. of turns of wire in length  $L$

$dw$  = Dia. of wire

$$\therefore n = \frac{L}{dw}$$

$$= \frac{L}{dw} \times \left( 2 \times \frac{\pi}{4} dw^2 \right) \times \sigma_w$$

$$= L \times \frac{\pi}{2} \times dw \times \sigma_w$$

Compressive force exerted by wire on cylinder for length  $L = 2 \times L \times t \times \sigma_c$

For equilibrium

Initial tensile force in wire = Compressive force on cylinder

$$\text{or } L \times \frac{\pi}{2} \times dw \times \sigma_w = 2 \times L \times t \times \sigma_c$$

$$\text{or } \sigma_c = \frac{\pi \times dw}{4t} \times \sigma_w \quad \dots [17.21 (A)]$$

$\sigma_c^*$  = Circumferential stress developed in the cylinder due to fluid pressure only (tensile)

$\sigma_w^*$  = Stress developed in the wire due to fluid pressure only (tensile)

Then resultant stress in the cylinder =  $(\sigma_c^* - \sigma_c)$

and resultant stress in wire =  $(\sigma_w + \sigma_w^*)$

**Hence wire-winding of thin cylinder is used :**

(i) to increase the pressure-carrying capacity of the cylinder, and

(ii) to reduce the chances of bursting of the cylinder in longitudinal direction.

The hoop stress (or circumferential stress) will be set up in the material of the cylinder if the bursting of the cylinder takes place in longitudinal direction. In wire winding of thin cylinders, the bursting of the cylinder should be considered only in longitudinal direction.

In such cases the bursting force (due to internal pressure) per cm length will be resisted by the pipe as well as the wires, offering tensile stresses.

The bursting force due to fluid along longitudinal section per cm length =  $p \times d \times L$  (Here  $p$ ,  $d$  and  $L$  should be in consistent units i.e., if  $p$  is in  $\text{N/mm}^2$ ,  $d$  and  $L$  should be in mm. Hence  $L = 1 \text{ cm} = 10 \text{ mm}$ .)

Resisting force of cylinder along longitudinal section per cm length

$$= \sigma_c^* \times 2L \times t$$

where  $\sigma_c^*$  = circumferential stress in cylinder due to fluid pressure.

(Here  $L$  and  $t$  are in mm.  $L = 1 \text{ cm} = 10 \text{ mm}$ )

Resisting force of wire per cm length

= No. of turns of wire  $\times$  (2  $\times$  Area of cross-section of wire)

$\times$  Stress in wire due to fluid pressure

$$= n \times 2 \times \frac{\pi}{4} dw^2 \times \sigma_w^* \quad \left( \text{where } n = \frac{L}{dw} \text{ and } dw = \text{Dia. of wire} \right)$$

$$= \frac{L}{dw} \times \frac{\pi}{2} \times dw^2 \times \sigma_w^* = L \times \frac{\pi}{2} \times dw \times \sigma_w^*$$

$\therefore$  Bursting force due to fluid pressure

= Resisting force of cylinder + resisting force of wire

$$p \times d \times L = \sigma_c^* \times 2L \times t + L \times \frac{\pi}{2} \times dw \times \sigma_w^*$$

or

$$p \times d = \sigma_c^* \times 2t + \frac{\pi}{2} \times dw \times \sigma_w^* \quad \dots [17.21 (B)]$$

The circumferential strain in the pipe is also equal to the strain in the steel wire.

Since the wire and cylinder remain in contact, the circumferential strain in the cylinder should be equal to the strain in the steel wire. Due to fluid pressure, the stresses set up in the cylinder are circumferential stress and longitudinal stress. But in the wire, there is only one stress.

∴ Circumferential strain in cylinder = Strain in wire

$$\left( \frac{\sigma_c^*}{E_c} - \frac{\mu \times \sigma_l^*}{E_c} \right) = \frac{\sigma_w^*}{E_w}$$

where  $E_c$  = Young's modulus for cylinder

$E_w$  = Young's modulus for wire

$\sigma_c^*$  = Circumferential stress in cylinder due to fluid pressure

$\sigma_l^*$  = Longitudinal stress in cylinder due to fluid pressure

$$= \frac{p \times d}{4 \times t}$$

$\sigma_w^*$  = Stress developed in wire due to fluid pressure.

**Problem 17.20.** A cast iron pipe of 200 mm internal diameter and 12 mm thick is wound closely with a single layer of circular steel wire of 5 mm diameter, under a tension of 60 N/mm<sup>2</sup>. Find the initial compressive stress in the pipe section. Also find the stresses set up in the pipe and steel wire, when water under a pressure of 3.5 N/mm<sup>2</sup> is admitted into the pipe. Take  $E$  for cast iron as  $1 \times 10^5$  N/mm<sup>2</sup> and for steel as  $2 \times 10^5$  N/mm<sup>2</sup>. Poisson's ratio is given as 0.3.

**Sol.** Given :

Internal diameter of pipe,  $d = 200$  mm

Pipe thickness,  $t = 12$  mm

Diameter of wire = 5 mm

Tension in wire = 60 N/mm<sup>2</sup>

Water pressure,  $p = 3.5$  N/mm<sup>2</sup>

$E$  for C.I.,  $E_c = 3 \times 10^5$  N/mm<sup>2</sup>

$E$  for steel,  $E_s = 2 \times 10^5$  N/mm<sup>2</sup>

Poisson's ratio,  $\mu = 0.3$

(i) Before the fluid under pressure is admitted in the cylinder

Let  $\sigma_w$  = Winding stress in wire

$$= 60 \text{ N/mm}^2$$

$P_c$  = Compressive force exerted by wire on cylinder

$\sigma_c$  = Compressive stress exerted by wire on cylinder.

Consider one cm length of the pipe. Number of turns of the wire of 1 cm pipe length

$$= \frac{\text{Length of pipe}}{\text{Diameter of wire}} = \frac{1 \text{ cm}}{0.5 \text{ cm}} = 2$$

The compressive force exerted by one turn of the wire on the cylinder (see Fig. 17.7)

$$= 2 \times \text{Area of cross-section of wire} \times \sigma_w$$

$$= 2 \times \frac{\pi}{4} \times 5^2 \times 60 \text{ N}$$

∴ Total compressive force exerted by the wire on the cylinder per cm length of the pipe

$$= \text{No. of turns} \times \text{Force exerted by one turn}$$

$$= 2 \times \left( 2 \times \frac{\pi}{4} \times 5^2 \times 60 \right) = 4712 \text{ N}$$

Sectional area of the cylinder which takes this compressive force

$$= 2 \times l \times t$$

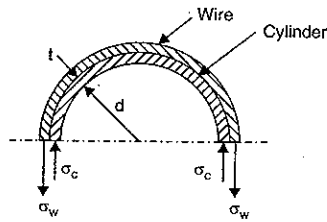

Fig. 17.7

$$= 2 \times 10 \times 12 \text{ mm}^2 \quad (\because \text{Here } l = 1 \text{ cm} = 10 \text{ mm and } t = 12 \text{ mm})$$

∴ Initial compressive stress in the material of the cylinder due to wire winding,

$$\sigma_c = \frac{\text{Total compressive force on the cylinder}}{\text{Sectional area of cylinder}}$$

$$= \frac{4712}{2 \times 10 \times 20} = 19.63 \text{ N/mm}^2. \quad \text{Ans.}$$

Hence before the water is admitted into the pipe, stresses in the pipe and wire are :

In the pipe = 19.63 N/mm<sup>2</sup> (compressive)

In the wire = 60 N/mm<sup>2</sup> (tensile)

(ii) Stresses due to fluid pressure alone

Let  $\sigma_c^*$  = Stress in the pipe due to fluid pressure 3.5 N/mm<sup>2</sup> alone

$\sigma_w^*$  = Stress in the wires due to pressure 3.5 N/mm<sup>2</sup> alone.

Consider 1 cm length of the pipe.

The force of fluid which tends to burst the cylinder along longitudinal section

$$= p.d.l = 3.5 \times 200 \times 10 \quad (\because l = 1 \text{ cm} = 10 \text{ mm})$$

$$= 7000 \text{ N}$$

...(i)

This bursting force is resisted by the cylinder as well as wire.

Resisting force of cylinder

$$= \text{Stress in the cylinder} \times \text{Area of cylinder resisting}$$

$$= \sigma_c^* \times 2l \times t = \sigma_c^* \times 2 \times 10 \times 12$$

$$= 240 \sigma_c^*$$

$$\text{Resisting force of wire} = \text{No. of turns} \times \left( 2 \times \frac{\pi}{4} \times 5^2 \right)$$

$$\times \text{Stress in wire due to fluid pressure}$$

$$= 2 \times \left( 2 \times \frac{\pi}{4} \times 5^2 \right) \times \sigma_w^* = 78.54 \sigma_w^*$$

∴ Total resisting force

$$= 240 \sigma_c^* + 78.54 \sigma_w^* \quad \dots(ii)$$

Equating the resisting force to the bursting force given by equations (i) and (ii), we get

$$= 240 \sigma_c^* + 78.54 \sigma_w^* = 7000 \quad \dots(iii)$$

Now we know that circumferential strain in cylinder is equal to the strain in wire.

But circumferential strain in cylinder

$$= \frac{\text{Circumferential stress}}{E} - \frac{\text{Longitudinal stress} \times \mu}{E}$$

$$= \frac{\sigma_c^*}{E_c} - \left( \frac{p \times d}{4t} \right) \times \frac{\mu}{E_c} \quad (\because \text{For pipe, } E = E_c)$$

$$= \frac{1}{E_c} \left( \sigma_c^* - \frac{3.5 \times 200}{4 \times 12} \times 0.3 \right)$$

$$= \frac{1}{E_c} (\sigma_c^* - 4.375) \quad \dots(iv)$$



$$\text{Strain in wire} = \frac{\sigma_w^*}{E_s} \quad (\because \text{For wire } E = E_s) \dots(v)$$

Equating equations (iv) and (v), we get

$$\frac{1}{E_c} (\sigma_c^* - 4.375) = \frac{\sigma_w^*}{E_s}$$

$$\begin{aligned} \text{or} \quad \sigma_w^* &= \frac{E_s}{E_c} (\sigma_c^* - 4.375) \\ &= \frac{2 \times 10^5}{1 \times 10^5} (\sigma_c^* - 4.375) = 2(\sigma_c^* - 4.375) \dots(vi) \end{aligned}$$

Substituting the above value in equation (iii), we get

$$240 \sigma_c^* + 78.54 \times [2(\sigma_c^* - 4.375)] = 7000$$

$$397.08 \sigma_c^* = 7687.225$$

$$\therefore \sigma_c^* = \frac{7687.225}{397.08} = 19.36 \text{ N/mm}^2 \text{ (tensile)}$$

Substituting the value of  $\sigma_c^*$  in equation (vi), we get

$$\sigma_w^* = 2(19.36 - 4.375) = 29.97 \text{ N/mm}^2 \text{ (tensile).}$$

(iii) Resultant stresses in pipe and wire

Resultant stress in pipe

$$\begin{aligned} &= \text{Initial stress in pipe} + \text{Stress due to fluid pressure alone} \\ &= 19.63 \text{ (compressive)} + 19.36 \text{ (tensile)} \\ &= \mathbf{0.27 \text{ N/mm}^2 \text{ (compressive). Ans.}} \end{aligned}$$

Resultant stress in wire

$$\begin{aligned} &= \text{Initial stress in wire} + \text{Stress due to fluid pressure alone} \\ &= 60 \text{ (tensile)} + 29.97 \text{ (tensile)} \\ &= \mathbf{89.97 \text{ N/mm}^2 \text{ (tensile). Ans.}} \end{aligned}$$

### 17.10. THIN SPHERICAL SHELLS

Fig. 17.8 shows a thin spherical shell of internal diameter 'd' and thickness 't' and subjected to an internal fluid pressure 'p'. The fluid inside the shell has a tendency to split the shell into two hemispheres along x-x axis.

The force (P) which has a tendency to split the shell

$$= p \times \frac{\pi}{4} d^2$$

The area resisting this force =  $\pi \cdot d \cdot t$

$\therefore$  Hoop or circumferential stress ( $\sigma_1$ ) induced in the material of the shell is given by,

$$\begin{aligned} \sigma_1 &= \frac{\text{Force } P}{\text{Area resisting the force } P} \\ &= \frac{p \times \frac{\pi}{4} d^2}{\pi \cdot d \cdot t} = \frac{p \cdot d}{4t} \end{aligned}$$

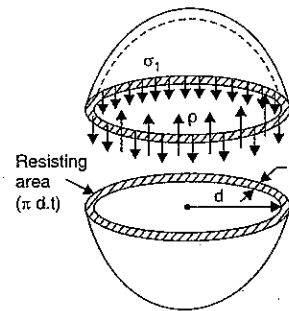

Fig. 17.8

The stress  $\sigma_1$  is tensile in nature.

The fluid inside the shell is also having tendency to split the shell into two hemispheres along Y-Y axis. Then it can be shown that the tensile hoop stress will also be equal to  $\frac{p \cdot d}{4t}$ . Let this stress is  $\sigma_2$ .

$$\therefore \sigma_2 = \frac{p \cdot d}{4t}$$

The stress  $\sigma_2$  will be at right angles to  $\sigma_1$ .

**Problem 17.21.** A vessel in the shape of a spherical shell of 1.20 m internal diameter and 12 mm shell thickness is subjected to pressure of 1.6 N/mm<sup>2</sup>. Determine the stress induced in the material of the vessel.

**Sol.** Given :

Internal diameter,  $d = 1.2 \text{ m} = 1.2 \times 10^3 \text{ mm}$

Shell thickness,  $t = 12 \text{ mm}$

Fluid pressure,  $p = 1.6 \text{ N/mm}^2$

The stress induced in the material of spherical shell is given by,

$$\sigma_1 = \frac{p \cdot d}{4t} = \frac{1.6 \times 1.2 \times 10^3}{4 \times 12} = \mathbf{40 \text{ N/mm}^2. \text{ Ans.}}$$

**Problem 17.22.** A spherical vessel 1.5 m diameter is subjected to an internal pressure of 2 N/mm<sup>2</sup>. Find the thickness of the plate required if maximum stress is not to exceed 150 N/mm<sup>2</sup> and joint efficiency is 75%.

**Sol.** Given :

Diameter of shell,  $d = 1.5 \text{ m} = 1.5 \times 10^3 \text{ mm}$

Fluid pressure,  $p = 2 \text{ N/mm}^2$

Stress in material,  $\sigma_1 = 150 \text{ N/mm}^2$

Joint efficiency,  $\eta = 75\% \text{ or } 0.75$

Let  $t =$  thickness of the plate.

The stress induced is given by,

$$\sigma_1 = \frac{p \cdot d}{4t \cdot \eta}$$

$$\text{or} \quad t = \frac{p \cdot d}{4 \cdot \eta \cdot \sigma_1} = \frac{2 \times 1.5 \times 10^3}{4 \times 0.75 \times 150} = \mathbf{6.67 \text{ mm. Ans.}}$$

### 17.11. CHANGE IN DIMENSIONS OF A THIN SPHERICAL SHELL DUE TO AN INTERNAL PRESSURE

In previous article, we have seen that the stresses  $\sigma_1$  and  $\sigma_2$  at any point are equal (each equal to  $p \cdot d / 4t$ ) and like. There is no shear stress at any point in the shell.

(Maximum shear stress =  $\frac{\sigma_1 - \sigma_2}{2} = \frac{p \cdot d}{4t} - \frac{p \cdot d}{4t} = 0$ ). The stresses  $\sigma_1$  and  $\sigma_2$  are acting at right angles to each other.

$\therefore$  Strain in any one direction is given by,

$$e = \frac{\sigma_1}{E} - \frac{\mu \times \sigma_1}{E}$$

$$= \frac{\sigma_1}{E} - \frac{\mu \times \sigma_1}{E} \quad \left( \because \sigma_1 = \sigma_2 = \frac{p \times d}{4t} \right)$$

$$= \frac{\sigma_1}{E} (1 - \mu) = \frac{p \times d}{4tE} (1 - \mu)$$

We know that strain in any direction is also

$$= \frac{\delta d}{d}$$

$$\therefore \frac{\delta d}{d} = \frac{p \times d}{4tE} (1 - \mu) \quad \dots(i)$$

**Volumetric strain**  $\left( \frac{dV}{V} \right)$

The ratio of change of volume to the original volume is known as volumetric strain. If

$V$  = original volume and  $dV$  = change in volume. Then  $\frac{dV}{V}$  = volumetric strain.

Let  $V$  = Original volume

$$= \frac{\pi}{6} d^3 \quad \left( \because \text{For a sphere, } V = \frac{4}{3} \pi r^3 = \frac{\pi}{6} d^3 \right)$$

Taking the differential of the above equation, we get

$$dV = \frac{\pi}{6} \times 3d^2 \times d(d)$$

$$\text{Hen.} \quad \frac{dV}{V} = \frac{\frac{\pi}{6} \times 3d^2 \times d(d)}{\frac{\pi}{6} \times d^3}$$

$$= 3 \frac{d(d)}{d} \quad \dots(ii)$$

But from equation (i), we have

$$\frac{\delta d}{d} \text{ or } \frac{d(d)}{d} = \frac{p \times d}{4tE} (1 - \mu)$$

Substituting this value in equation (ii), we get

$$\frac{dV}{V} = \frac{3 \times p \times d}{4tE} (1 - \mu).$$

**Problem 17.23.** A spherical shell of internal diameter 0.9 m and of thickness 10 mm is subjected to an internal pressure of 1.4 N/mm<sup>2</sup>. Determine the increase in diameter and increase

in volume. Take  $E = 2 \times 10^5$  N/mm<sup>2</sup> and  $\mu = \frac{1}{3}$ .

**Sol. Given :**

Internal diameter,  $d = 0.9 \text{ m} = 0.9 \times 10^3 \text{ mm}$

Thickness of shell,  $t = 10 \text{ mm}$

Fluid pressure,  $p = 1.4 \text{ N/mm}^2$

Value of  $E = 2 \times 10^5 \text{ N/mm}^2$

Value of  $\mu = \frac{1}{3}$

Using the relation,

$$\frac{\delta d}{d} = \frac{p \times d}{4tE} (1 - \mu)$$

or

$$\frac{\delta d}{d} = \frac{p \times d}{4tE} (1 - \mu)$$

$$= \frac{1.4 \times (0.9 \times 10^3)}{4 \times 10 \times 2 \times 10^5} \left( 1 - \frac{1}{3} \right) = 105 \times 10^{-6}$$

$\therefore$  Increase in diameter,

$$\delta d = 105 \times 10^{-6} \times 0.9 \times 10^3 \\ = 94.5 \times 10^{-3} \text{ mm} = \mathbf{0.0945 \text{ mm. Ans.}}$$

Now, volumetric strain =  $3 \times \frac{\delta d}{d}$

$$= 3 \times 105 \times 10^{-6} = 315 \times 10^{-6}$$

or

$$\frac{\delta V}{V} = 315 \times 10^{-6}$$

$\therefore$  Increase in volume,

$$\delta V = 315 \times 10^{-6} \times V \\ = 315 \times 10^{-6} \times \left( \frac{\pi}{6} d^3 \right) \quad \left( \because V = \frac{\pi}{6} d^3 \text{ for a sphere} \right) \\ = 315 \times 10^{-6} \times \frac{\pi}{6} \times (0.9 \times 10^3)^3 \\ = \mathbf{12028.5 \text{ mm}^3. \text{ Ans.}}$$

## 17.12. ROTATIONAL STRESSES IN THIN CYLINDERS

Fig. 17.9 shows a thin cylinder rotating at an angular velocity  $\omega$  about its axis.

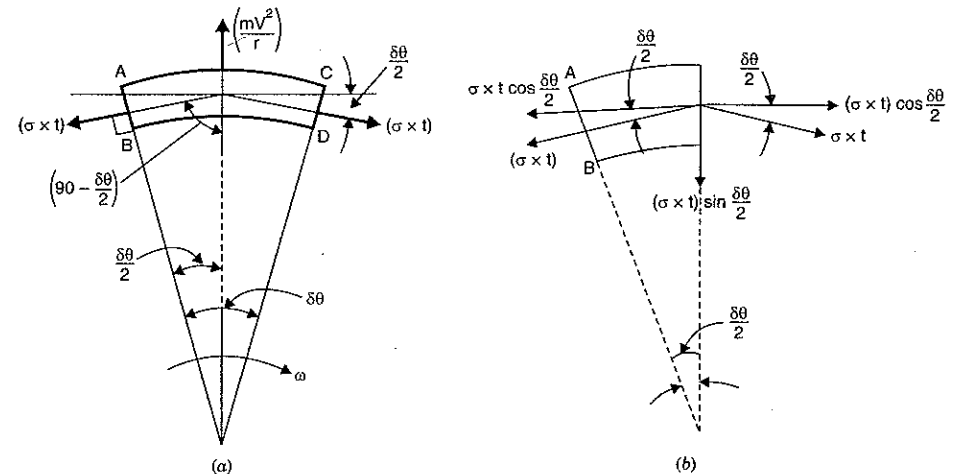

Fig. 17.9

- Let  $r$  = mean radius of the cylinder  
 $t$  = thickness of the cylinder  
 $\omega$  = angular speed of the cylinder  
 $\rho$  = density of the material of cylinder

Due to rotation of cylinder, centrifugal force will be acting on the walls of the cylinder. This centrifugal force will produce a circumferential (or hoop) stress  $\sigma$ . For a thin cylinder, this hoop stress  $\sigma$  may be assumed constant.

Consider a small element  $ABCD$  of the rotating cylinder. Let this element makes an angle  $\delta\theta$  at the centre as shown in Fig. 17.9 (a). Consider unit length of this element perpendicular to the plane of paper.

The forces acting on the element are :

(i) Centrifugal force  $\left(\frac{mV^2}{r} \text{ or } m\omega^2 r\right)$  acting radially outwards. Here  $m$  is the mass of the element per unit length.

$$\begin{aligned} \therefore m &= \text{mass of element} \\ &= \rho \times \text{volume of element} \\ &= \rho \times (\text{area of element}) \times \text{unit length} \\ &= \rho \times [(r \times \delta\theta) \times t] \times 1 \\ &= \rho \times r \times \delta\theta \times t \\ \therefore \text{Centrifugal force} &= m\omega^2 r = (\rho r \delta\theta t) \omega^2 r \\ &= \rho r^2 \times \omega^2 \times \delta\theta \times t \end{aligned}$$

(ii) Tensile force due to hoop stress ( $\sigma$ ) on the face  $AB$ . This force is equal to  $(\sigma \times t \times 1)$  and acts perpendicular to face  $AB$ .

(iii) Tensile force due to hoop stress ( $\sigma$ ) on the face  $CD$ . This force is equal to  $(\sigma \times t \times 1)$  and acts perpendicular to face  $CD$ .

The horizontal component  $\sigma \times t \times \cos \frac{\delta\theta}{2}$  on the face  $AB$  and  $CD$  are equal and opposite.

The radial components  $\sigma \times t \times \sin \frac{\delta\theta}{2}$  are acting towards centre and they will be added.

Resolving the forces radially for equilibrium, we get

$$\text{Centrifugal force} = \sigma t \times \sin \frac{\delta\theta}{2} + \sigma t \times \sin \frac{\delta\theta}{2}$$

$$\begin{aligned} \text{or } \rho r^2 \times \omega^2 \times \delta\theta \times t &= 2 \times \sigma \times t \times \sin \frac{\delta\theta}{2} \\ &= 2 \times \sigma \times t \times \frac{\delta\theta}{2} \quad \left(\text{As } \delta\theta \text{ is very small, hence } \sin \frac{\delta\theta}{2} \approx \frac{\delta\theta}{2}\right) \end{aligned}$$

$$\begin{aligned} \text{or } \rho r^2 \times \omega^2 &= \sigma \\ \text{or } \sigma &= \rho r^2 \times \omega^2 \quad \dots(17.22) \end{aligned} \quad \text{(Cancelling } \delta\theta \times t \text{ to both sides)}$$

The equation (17.22) gives the expression for hoop stress produced in a thin cylinder due to rotation. The above equation can also be used approximately for rim-type flywheels.

**Problem 17.24.** A rim-type flywheel is rotating at a speed of 2400 r.p.m. If the mean diameter of the flywheel is 750 mm and density of the material of the wheel is 8000 kg/m<sup>3</sup>, then find the hoop stress produced in the rim due to rotation.

**Sol. Given :**

$$\text{Speed, } N = 2400 \text{ r.p.m. } \therefore \omega = \frac{2\pi N}{60} = \frac{2\pi \times 2400}{60} = 80\pi \text{ rad/s}$$

$$\text{Mean dia, } d = 750 \text{ mm } \therefore r = \frac{750}{2} = 375 \text{ mm} = 0.375 \text{ m}$$

$$\text{Density, } \rho = 8000 \text{ kg/m}^3$$

Let  $\sigma$  = hoop stress produced.

Using equation (17.22), we get

$$\begin{aligned} \sigma &= \rho \times r^2 \times \omega^2 \\ &= 8000 \times 0.375^2 \times (80\pi)^2 \text{ N/m}^2 \\ &= 71.0485 \times 10^6 \text{ N/m}^2 = \mathbf{71.0485 \text{ MN/m}^2}. \quad \text{Ans.} \end{aligned}$$

**Problem 17.25.** If in problem 17.24  $E = 200 \text{ GN/m}^2$  then what will be the change in diameter of the flywheel due to rotation.

**Sol. Given :**

From problem 17.24,

$$\text{Original dia, } d = 750 \text{ mm, } \sigma = 71.0485 \text{ MN/m}^2 = 71.0485 \times 10^6 \text{ N/m}^2$$

$$E = 200 \text{ GN/m}^2 = 200 \times 10^9 \text{ N/m}^2$$

Due to hoop stress, circumferential strain =  $\frac{\sigma}{E}$

$$= \frac{71.0485 \times 10^6}{200 \times 10^9} = 0.3552 \times 10^{-3}$$

But circumferential strain is also equal to  $\frac{\delta d}{d}$

where  $\delta d$  = change in diameter

$$\therefore \frac{\delta d}{d} = 0.3552 \times 10^{-3}$$

$$\begin{aligned} \text{or } \delta d &= 0.3552 \times 10^{-3} \times d = 0.3552 \times 10^{-3} \times 750 \\ &= \mathbf{0.2664 \text{ mm}}. \quad \text{Ans.} \end{aligned}$$

**Problem 17.26.** Find the speed of rotation of a wheel of diameter 750 mm, if the hoop stress is not to exceed 120 MN/m<sup>2</sup>. The wheel has a thin rim and density of the wheel is 7200 kg/m<sup>3</sup>.

**Sol. Given :**

$$\text{Dia, } d = 750 \text{ mm } \therefore r = \frac{750}{2} = 375 \text{ mm} = 0.375 \text{ m}$$

$$\text{Max. hoop stress, } \sigma = 120 \text{ MN/m}^2 = 120 \times 10^6 \text{ N/m}^2$$

$$\text{Density, } \rho = 7200 \text{ kg/m}^3.$$

Using equation (17.22), we get

$$\begin{aligned} \sigma &= \rho \times r^2 \times \omega^2 \\ \text{or } 120 \times 10^6 &= 7200 \times 0.375^2 \times \omega^2 \end{aligned}$$

$$\text{or } \omega = \sqrt{\frac{120 \times 10^6}{7200 \times 0.375^2}} = 344.26 \text{ rad/s}$$

But 
$$\omega = \frac{2\pi N}{60}$$

$$N = \frac{60 \times \omega}{2\pi} = \frac{60 \times 344.26}{2\pi} = 3287.4 \text{ r.p.m. Ans.}$$

### HIGHLIGHTS

- If the thickness of the wall of the cylindrical vessel is less than 1/20 of its internal diameter, the cylindrical vessel is known as a thin cylinder. Or if  $\frac{t}{d} < \frac{1}{20}$ , the cylinder is a thin cylinder.
- In case of thin cylinders, the stress distribution is assumed uniform over the thickness of wall.
- When a thin cylindrical vessel is subjected to internal fluid pressure, the stresses set up in the material of a thin cylinder are :
  - Circumferential or hoop stress and
  - Longitudinal stress.
- The circumferential stress ( $\sigma_1$ ) is given by
 
$$\sigma_1 = \frac{p \times d}{2t}$$
 where  $p$  = Internal fluid pressure,  
 $d$  = Internal diameter of the thin cylinder, and  
 $t$  = Thickness of the wall of the cylinder.
- The longitudinal stress ( $\sigma_2$ ) is given by
 
$$\sigma_2 = \frac{p \times d}{4t}$$
- The circumferential and longitudinal stresses are tensile stresses.
- The circumferential stress is twice the longitudinal stress.
- If the thickness of the thin cylinder is to be determined then circumferential stress is used.
- Maximum shear stress at any point in a thin cylinder, subjected to internal fluid pressure is given by,
 
$$\text{Max. shear stress} = \frac{\sigma_1 - \sigma_2}{2} = \frac{pd}{8t}$$
- If  $\eta_l$  = Efficiency of longitudinal joint, and  
 $\eta_c$  = Efficiency of a circumferential joint  
 then the circumferential stress ( $\sigma_1$ ) and longitudinal stress ( $\sigma_2$ ) are given by
 
$$\sigma_1 = \frac{p \times d}{2t \times \eta_l} \text{ and } \sigma_2 = \frac{p \times d}{4t \times \eta_c}$$
- In longitudinal joint, the circumferential stress is developed whereas in circumferential joint the longitudinal stress is developed.
- The circumferential strain ( $e_1$ ) and longitudinal strain ( $e_2$ ) are given by
 
$$e_1 = \frac{pd}{2tE} \left(1 - \frac{1}{2} \times \mu\right) \text{ and } e_2 = \frac{pd}{2tE} \left(\frac{1}{2} - \mu\right)$$
- The circumferential strain ( $e_1$ ) and longitudinal strain ( $e_2$ ) are also equal to
 
$$e_1 = \frac{\delta d}{d} \text{ and } e_2 = \frac{\delta L}{L}$$

14. The change in diameter, of a cylindrical shell subjected to internal fluid pressure  $p$ , is given by

$$\delta d = \frac{pd^2}{2tE} \left(1 - \frac{1}{2} \times \mu\right)$$

where  $\mu$  = Poisson's ratio.

15. The change in length, of a cylindrical shell subjected to internal fluid pressure  $p$ , is given by

$$\delta L = \frac{p \times d \times L}{2tE} \left(\frac{1}{2} - \mu\right)$$

16. The change in volume, of a cylindrical shell subjected to internal fluid pressure  $p$ , is given by

$$\delta V = \frac{pd}{2Et} \left(\frac{5}{2} - 2 \times \mu\right) \times \text{volume.}$$

17. When a thin cylindrical shell is subjected to internal fluid pressure  $p$  and a torque, then the principal stresses are given by

$$\text{Major principal stress} = \frac{\sigma_1 + \sigma_2}{2} + \sqrt{\left(\frac{\sigma_1 - \sigma_2}{2}\right)^2 + \tau^2}$$

$$\text{Minor principal stress} = \frac{\sigma_1 + \sigma_2}{2} - \sqrt{\left(\frac{\sigma_1 - \sigma_2}{2}\right)^2 + \tau^2} \text{ and}$$

$$\text{Maximum shear stress} = \frac{1}{2} [\text{Major principal stress} - \text{Minor principal stress}]$$

where  $\sigma_1$  = Circumferential stress,

$\sigma_2$  = Longitudinal stress, and

$\tau$  = Shear stress due to torque.

18. The hoop stress in the thin spherical shell is given by

$$\sigma_1 = \frac{p \times d}{4 \times t}$$

19. Wire-winding of thin cylinder is necessary for

- increasing the pressure-carrying capacity of the cylinder and
- reducing the chances of bursting of the cylinder in longitudinal direction.

20. For wire-winding of thin cylinders the equations used are :

- Before fluid is admitted into the cylinder

$$n \times \left(2 \times \frac{\pi}{4} dw^2\right) \times \sigma_w = (2L \times t) \times \sigma_c$$

$$\text{where } n = \frac{L}{dw}$$

- After fluid is admitted

$$(a) p \times d \times L = 2L \times t \times \sigma_c^* + n \times \left(2 \times \frac{\pi}{4} dw^2\right) \times \sigma_w^*$$

$$(b) \text{circumferential strain in cylinder} = \text{Strain in wire.}$$

### EXERCISE 17

#### (A) Theoretical Problems

- Define thin cylinders. Name the stresses set up in a thin cylinder subjected to internal fluid pressure.

2. (a) Prove that the circumferential stress ( $\sigma_1$ ) and longitudinal stress ( $\sigma_2$ ) are given by,

$$\sigma_1 = \frac{p \times d}{2t}$$

$$\sigma_2 = \frac{p \times d}{4t}$$

where  $p$  = Internal fluid pressure

$d$  = Internal diameter of thin cylinder

$t$  = Thickness of wall of the thin cylinder.

- (b) Derive an expression for circumferential stress and longitudinal stress for a thin shell subjected to an internal pressure. (Bhavnagar University, Feb. 1992)

3. (a) Derive the expressions for hoop stress and longitudinal stress in a thin cylinder with ends closed by rigid flanges and subjected to an internal fluid pressure  $p$ . Take the internal diameter and shell thickness of the cylinder to be ' $d$ ' and ' $t$ ' respectively.

(AMIE, Summer 1983, 85)

- (b) Derive from the first principles the expressions for circumferential and longitudinal stresses in a thin cylinder closed at both ends and subjected to internal fluid pressure.

(AMIE, Winter 1988)

4. Show that in thin cylinder shells subjected to internal fluid pressure, the circumferential stress is twice the longitudinal stress. (AMIE, Summer 1982)
5. While resigning a cylindrical vessel, which stress should be used for calculating the thickness of the cylindrical vessel?
6. Prove that maximum shear stress at any point in a thin cylinder, subjected to internal fluid pressure is given by,

$$\text{Max. shear stress} = \frac{p \times d}{8t}$$

where  $p$  = Internal fluid pressure,

$d$  = Internal dia. of thin cylinder, and

$t$  = Wall thickness of cylinder.

7. Find the expression for circumferential stress and longitudinal stress for a longitudinal joint and circumferential joint.
8. Prove that the circumferential strain ( $e_1$ ) and longitudinal strain ( $e_2$ ), produced in a thin cylinder when subjected to internal fluid pressure ( $p$ ), are given by

$$e_1 = \frac{pd}{2tE} \left( 1 - \frac{1}{2} \times \mu \right) \text{ and}$$

$$e_2 = \frac{pd}{2tE} \left( \frac{1}{2} - \mu \right)$$

where  $p$  = Internal fluid pressure,

$d$  = Internal dia. of thin cylinder,

$t$  = Thickness of wall of thin cylinder, and

$\mu$  = Poisson's ratio.

9. A cylindrical shell is subjected to internal fluid pressure, find an expression for change in diameter and change in length of the cylinder.
10. (a) Prove that volumetric strain in case of a thin cylinder, subjected to internal fluid pressure is equal to two times the circumferential strain plus longitudinal strain.
- (b) Show that when a thin walled cylindrical vessel of dia.  $D$ , length  $L$  and thickness  $t$  is subjected to an internal pressure  $p$ , the change in volume is given by

$$\frac{\pi \times p \times D^3 \times L}{16tE} (5 - 4 \times \mu).$$

(AMIE, Summer 1990)

11. Find an expression for the change in volume of a thin cylindrical shell subjected to internal fluid pressure.
12. Write down the expression for major principal stress, minor principal stress and maximum shear stress when a thin cylindrical shell is subjected to internal fluid pressure and a torque.
13. Show that when a thin walled spherical vessel of dia. ' $d$ ' and thickness ' $t$ ' is subjected to internal fluid pressure ' $p$ ', the increase in volume equal to

$$\frac{\pi}{8} \times \frac{pd^4}{tE} \left( 1 - \frac{1}{\mu} \right)$$

where  $E$  = Elastic modulus and

$\mu$  = Poisson's ratio.

(AMIE, Summer 1989)

### (B) Numerical Problems

1. A cylindrical pipe of diameter 2.0 m and thickness 2.0 cm is subjected to an internal fluid pressure of 1.5 N/mm<sup>2</sup>. Determine :  
(i) Longitudinal stress, and  
(ii) Circumferential stress developed in the pipe material. [Ans. 37.5 N/mm<sup>2</sup>, 75 N/mm<sup>2</sup>]
2. A cylinder of internal diameter 3.0 m and of thickness 6 cm contains a gas. If the tensile stress in the material is not to exceed 70 N/mm<sup>2</sup>, determine the internal pressure of the gas. [Ans. 2.8 N/mm<sup>2</sup>]
3. A cylinder of internal diameter 0.60 m contains air at a pressure of 7.5 N/mm<sup>2</sup> (gauge). If the maximum permissible stress induced in the material is 75 N/mm<sup>2</sup>, find the thickness of the cylinder. [Ans. 3 cm]
4. A thin cylinder of internal diameter 2.0 m contains a fluid at an internal pressure of 3 N/mm<sup>2</sup>. Determine the maximum thickness of the cylinder if (i) the longitudinal stress is not to exceed 30 N/mm<sup>2</sup> and (ii) the circumferential stress is not to exceed 40 N/mm<sup>2</sup>. [Ans. 7.5 cm]
5. A water main 90 cm diameter contains water at a pressure head of 110 m. If the weight density of water is 9810 N/mm<sup>3</sup>, find the thickness of the metal required for the water main. Given the permissible stress as 22 N/mm<sup>2</sup>. [Ans. 2.25 cm]
6. A boiler is subjected to an internal steam pressure of 3 N/mm<sup>2</sup>. The thickness of the boiler plate is 2.5 cm and the permissible tensile stress is 125 N/mm<sup>2</sup>. Find out the maximum diameter, when efficiency of longitudinal joint is 90% and that of circumferential joint is 35%. [Ans. 145.83 cm]
7. A boiler shell is to be made of 20 mm thick plate having a limiting tensile stress of 125 N/mm<sup>2</sup>. If the efficiencies of the longitudinal and circumferential joints are 80% and 30% respectively, determine :  
(i) The maximum permissible diameter of the shell for an internal pressure of 2.5 N/mm<sup>2</sup>, and  
(ii) Permissible intensity of internal pressure when the shell diameter is 1.6 m. [Ans. (i) 120 cm, (ii) 1.875 N/mm<sup>2</sup>]
8. A cylinder of thickness 2.0 cm has to withstand maximum internal pressure of 2 N/mm<sup>2</sup>. If the ultimate tensile stress in the material of the cylinder is 292 N/mm<sup>2</sup>, factor of safety 4 and joint efficiency 80%, determine the diameter of the cylinder. [Ans. 116.8 cm]
9. A thin cylindrical shell of 120 cm diameter, 1.5 cm thick and 6 m long is subjected to internal fluid pressure of 2.5 N/mm<sup>2</sup>. If the value of  $E = 2 \times 10^5$  N/mm<sup>2</sup> and Poisson's ratio = 0.3, calculate :  
(i) change in diameter, (ii) change in length, and (iii) change in volume. [Ans. (i) 0.051 m (ii) 0.06 cm (iii) 6449.7 cm<sup>3</sup>]
10. A cylindrical shell 100 cm long 20 cm internal diameter having thickness of metal as 10 mm is filled with fluid at atmospheric pressure. If an additional 20 cm<sup>3</sup> of fluid is pumped into cylinder find (i) the pressure exerted by the fluid on the cylinder and (ii) the hoop stress induced. Take  $E = 2 \times 10^5$  N/mm<sup>2</sup> and  $\mu = 0.3$ . [Ans. 10.05 N/mm<sup>2</sup>, 100.52 N/mm<sup>2</sup>]

11. A cylindrical vessel whose ends are closed by means of rigid flange plates, is made of steel plate 4 mm thick. The length and the internal diameter of the vessel are 100 cm and 30 cm respectively. Determine the longitudinal and hoop stresses in the cylindrical shell due to an internal fluid pressure of 2 N/mm<sup>2</sup>. Also calculate the increase in length, diameter and volume of the vessel. Take  $E = 2 \times 10^5$  N/mm<sup>2</sup> and  $\mu = 0.3$ .  
 [Ans. 37.5 N/mm<sup>2</sup>, 75 N/mm<sup>2</sup>, 0.075 cm, 0.0095 cm, 50.36 cm<sup>3</sup>]
12. A thin cylindrical tube 100 mm internal diameter and 5 mm thick is closed at the ends and is subjected to an internal pressure of 5 N/mm<sup>2</sup>. A torque of 22000 Nm is also applied to the tube. Find the hoop stress, longitudinal stress, maximum and minimum principal stresses and the maximum shear stress.  
 [Ans. 50 N/mm<sup>2</sup>, 25 N/mm<sup>2</sup>, 28 N/mm<sup>2</sup>, 68.16 N/mm, 6.84 N/mm<sup>2</sup>, 30.66 N/mm<sup>2</sup>]
13. A copper cylinder, 100 cm long, 50 cm external diameter and wall thickness 5 mm has its both ends closed by rigid blank flanges. It is initially full of oil at atmospheric pressure. Calculate the additional volume of oil which must be pumped into it in order to raise the oil pressure to 4 N/mm<sup>2</sup> above atmospheric pressure. For copper assume,  $E = 1.0 \times 10^5$  N/mm<sup>2</sup> and Poisson's ratio = 0.3. Take bulk modulus of oil as  $2.5 \times 10^3$  N/mm<sup>2</sup>.  
 [Ans. 486.3 cm<sup>3</sup>]
14. A vessel in the shape of a spherical shell of 1.4 m internal diameter and 4.5 mm thickness is subjected to a pressure of 1.8 N/mm<sup>2</sup>. Determine the stress induced in the material of the vessel.  
 [Ans. 140 N/mm<sup>2</sup>]
15. A thin spherical of 1.20 m internal diameter is subjected to an internal pressure of 1.6 N/mm<sup>2</sup>. If the permissible stress in the plate material is 80 N/mm<sup>2</sup> and joint efficiency is 75%, find the minimum thickness.  
 [Ans. 8 mm]
16. A thin spherical shell of internal diameter 1.5 m and of thickness 8 mm is subjected to an internal pressure of 1.5 N/mm<sup>2</sup>. Determine the increase in diameter and increase in volume. Take  $E = 2 \times 10^5$  N/mm<sup>2</sup> and  $\mu = 0.3$ .  
 [Ans. 0.369 mm,  $1304 \times 10^3$  mm<sup>3</sup>]

# 18

## Thick Cylinders and Spheres

### 18.1. INTRODUCTION

In the last chapter, we have mentioned that if the ratio of thickness to internal diameter of a cylindrical shell is less than about 1/20, the cylindrical shell is known as thin cylinders. For them it may be assumed with reasonable accuracy that the hoop and longitudinal stresses are constant over the thickness and the radial stress is small and can be neglected. If the ratio of thickness to internal diameter is more than 1/20, then cylindrical shell is known as thick cylinders.

The hoop stress in case of a thick cylinder will not be uniform across the thickness. Actually the hoop stress will vary from a maximum value at the inner circumference to a minimum value at the outer circumference.

### 18.2. STRESSES IN A THICK CYLINDRICAL SHELL

Fig. 18.1 (a) shows a thick cylinder subjected to an internal fluid pressure.

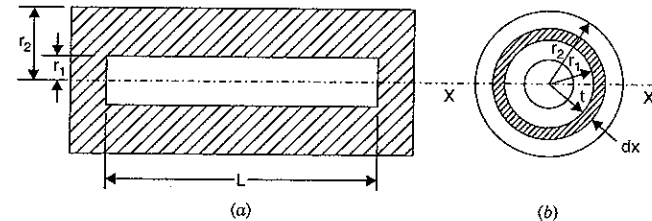

Fig. 18.1

- Let  $r_2$  = External radius of the cylinder,
- $r_1$  = Internal radius of the cylinder, and
- $L$  = Length of cylinder.

Consider an elementary ring of the cylinder of radius  $x$  and thickness  $dx$  as shown in Fig. 18.1 (b) and 18.2.

- Let  $p_x$  = Radial pressure on the inner surface of the ring
- $p_x + dp_x$  = Radial pressure on the outer surface of the ring
- $\sigma_x$  = Hoop stress induced in the ring.

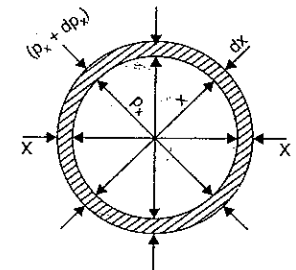

Fig. 18.2

Take a longitudinal section  $x-x$  and consider the equilibrium of half of the ring of Fig. 18.2 as shown in Fig. 18.2 (a) or in Fig. 18.2 (b).

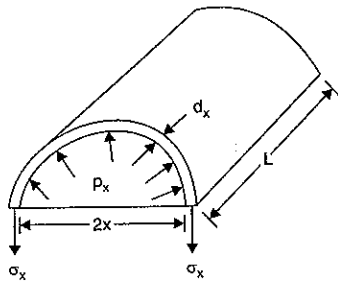

Fig. 18.2 (a)

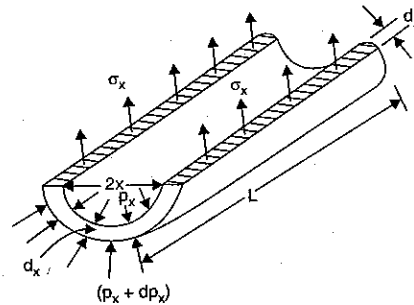

Fig. 18.2 (b)

Bursting force

$$\begin{aligned} &= p_x (2xL) - (p_x + dp_x) \times 2(x + dx) \cdot L \\ &= 2L [p_x \cdot x - (p_x \cdot x + p_x \cdot dx + x dp_x + dp_x \cdot dx)] \\ &= 2L [-p_x \cdot dx - x \cdot dp_x] \quad (\text{Neglecting } dp_x \cdot dx \text{ which is a small quantity}) \\ &= -2L (p_x dx + x \cdot dp_x) \quad \dots(i) \end{aligned}$$

Resisting force = Hoop stress  $\times$  Area on which it acts =  $\sigma_x \times 2dx \cdot L$   $\dots(ii)$

Equating the resisting force to the bursting force, we get

$$\sigma_x \times 2dx \cdot L = -2L (p_x \cdot dx + x \cdot dp_x) \quad \dots(iii)$$

or

$$\sigma_x = -p_x - x \frac{dp_x}{dx} \quad \dots(iii)$$

The longitudinal strain at any point in the section is constant and is independent of the radius. This means that cross-sections remain plane after straining and this is true for sections, remote from any end fixing. As longitudinal strain is constant, hence longitudinal stress will also be constant.

Let  $\sigma_2$  = Longitudinal stress.

Hence at any point at a distance  $x$  from the centre, three principal stresses are acting :

They are :

- (i) the radial compressive stress,  $p_x$
- (ii) the hoop (or circumferential) tensile stress,  $\sigma_x$
- (iii) the longitudinal tensile stress  $\sigma_2$ .

The longitudinal strain ( $e_2$ ) at this point is given by,

$$e_2 = \frac{\sigma_2}{E} - \frac{\mu\sigma_x}{E} + \frac{\mu p_x}{E}$$

But longitudinal strain is constant.

$$\therefore \frac{\sigma_2}{E} - \frac{\mu\sigma_x}{E} + \frac{\mu p_x}{E} = \text{constant}$$

But  $\sigma_2$  is also constant, and for the material of the cylinder  $E$  and  $\mu$  are constant.

$$\begin{aligned} \therefore \sigma_x - p_x &= \text{constant} \\ &= 2a \text{ where } a \text{ is constant} \end{aligned}$$

$$\therefore \sigma_x = p_x + 2a \quad \dots(iv)$$

Equating the two values of  $\sigma_x$  given by equations (iii) and (iv), we get

$$p_x + 2a = -p_x - x \frac{dp_x}{dx}$$

or

$$x \cdot \frac{dp_x}{dx} = -p_x - p_x - 2a = -2p_x - 2a$$

or

$$\frac{dp_x}{dx} = -\frac{2p_x}{x} - \frac{2a}{x} = -\frac{2(p_x + a)}{x}$$

or

$$\frac{dp_x}{(p_x + a)} = -\frac{2dx}{x}$$

Integrating the above equation, we get

$$\log_e (p_x + a) = -2 \log_e x + \log_e b$$

where  $\log_e b$  is a constant of integration.

The above equation can also be written as

$$\log_e (p_x + a) = -\log_e x^2 + \log_e b$$

$$= \log_e \frac{b}{x^2}$$

$$\therefore p_x + a = \frac{b}{x^2}$$

or

$$p_x = \frac{b}{x^2} - a \quad \dots(18.1)$$

Substituting the values of  $p_x$  in equation (iv), we get

$$\sigma_x = \frac{b}{x^2} - a + 2a = \frac{b}{x^2} + a \quad \dots(18.2)$$

The equation (18.1) gives the radial pressure  $p_x$  and equation (18.2) gives the hoop stress at any radius  $x$ . These two equations are called *Lame's equations*. The constants 'a' and 'b' are obtained from boundary conditions, which are :

- (i) at  $x = r_1$ ,  $p_x = p_0$  or the pressure of fluid inside the cylinder, and
- (ii) at  $x = r_2$ ,  $p_x = 0$  or atmosphere pressure.

After knowing the values of 'a' and 'b', the hoop stress can be calculated at any radius.

**18.2.1. Alternate Method for finding stresses in a thick-cylinder.** In case of thick-cylinders, due to internal fluid pressure, the three principal stresses acting at a point are :

- (i) radial pressure ( $p$ ) which is compressive,
- (ii) circumferential stress or hoop stress ( $\sigma_1$ ) which is tensile, and
- (iii) longitudinal stress ( $\sigma_2$ ), which is also tensile.

Let  $e_1$  = circumferential strain,

$e_2$  = longitudinal strain, and

$e_r$  = radial strain.

In case of thick-cylinder, it may be assumed that longitudinal strain ( $e_2$ ) is constant, which means that cross-section remain plane after straining.

Consider a circular ring of radius  $r$  and thickness ' $dr$ '. Due to internal fluid pressure, let the radius  $r$  increases to  $(r + u)$  and increase in the thickness  $dr$  be  $du$ .

∴ Initial radius =  $r$  whereas final radius =  $(r + u)$

$$\begin{aligned} \text{Now circumferential strain} &= \frac{\text{Final circumference} - \text{Original circumference}}{\text{Original circumference}} \\ &= \frac{2\pi(r + u) - 2\pi r}{2\pi r} = \frac{2\pi u}{2\pi r} = \frac{u}{r} \end{aligned}$$

$$e_1 = \frac{u}{r} \quad (\because \text{Circumferential strain} = e_1) \quad \dots(i)$$

$$\begin{aligned} \text{Now original thickness of ring} &= dr \\ \text{Final thickness of ring} &= dr + du \end{aligned}$$

$$\begin{aligned} \therefore \text{Radial strain} &= \frac{\text{Final thickness of ring} - \text{Original thickness}}{\text{Original thickness}} \\ &= \frac{(dr + du) - dr}{dr} = \frac{du}{dr} \end{aligned}$$

$$e_r = \frac{du}{dr} \quad (\because \text{radial strain} = e_r) \quad \dots(ii)$$

The circumferential strain, longitudinal strain and radial strains in terms of stresses and Poisson's ratio are also given by,

$$e_1 = \frac{\sigma_1}{E} - \frac{\mu\sigma_2}{E} - \left(\frac{-\mu p}{E}\right) = \frac{\sigma_1}{E} - \frac{\mu\sigma_2}{E} + \frac{\mu p}{E} \quad (\because p \text{ is compressive}) \quad \dots(iii)$$

$$e_2 = \frac{\sigma_2}{E} - \frac{\mu\sigma_1}{E} + \frac{\mu p}{E} \quad \dots(iv)$$

$$e_r = \frac{-p}{E} - \frac{\mu\sigma_1}{E} - \frac{\mu\sigma_2}{E} \quad \dots(v)$$

Equating the two values of circumferential strain ( $e_1$ ) given by equations (i) and (iii). Also equate the two values of radial strain ( $e_r$ ) given by equations (ii) and (v), we get

$$\frac{u}{r} = \frac{\sigma_1}{E} - \frac{\mu\sigma_2}{E} + \frac{\mu p}{E} \quad [\text{Equations (i) = (iii)}] \quad \dots(vi)$$

$$\frac{du}{dr} = \frac{-p}{E} - \frac{\mu\sigma_1}{E} - \frac{\mu\sigma_2}{E} \quad [\text{Equations (ii) = (v)}] \quad \dots(vii)$$

Let us first eliminate 'u' from equations (vi) and (vii).

From equation (vi),

$$u = \left( \frac{\sigma_1}{E} - \frac{\mu\sigma_2}{E} + \frac{\mu p}{E} \right) \times r$$

Differentiating the above equation with respect to  $r$ , we get

$$\frac{du}{dr} = \left( \frac{\sigma_1}{E} - \frac{\mu\sigma_2}{E} + \frac{\mu p}{E} \right) + \frac{r}{E} \left( \frac{d\sigma_1}{dr} - \frac{\mu d\sigma_2}{dr} + \frac{\mu dp}{dr} \right) \quad \dots(viii)$$

(∵  $\sigma_1, \sigma_2$  and  $p$  are function of  $r$ )

Equating the two values of  $\frac{du}{dr}$  given by equations (vii) and (viii),

$$\frac{-p}{E} - \frac{\mu\sigma_1}{E} - \frac{\mu\sigma_2}{E} = \left( \frac{\sigma_1}{E} - \frac{\mu\sigma_2}{E} + \frac{\mu p}{E} \right) + \frac{r}{E} \left( \frac{d\sigma_1}{dr} - \frac{\mu d\sigma_2}{dr} + \frac{\mu dp}{dr} \right)$$

$$\text{or} \quad -p - \mu\sigma_1 - \mu\sigma_2 = \sigma_1 - \mu\sigma_2 + \mu p + r \left( \frac{d\sigma_1}{dr} - \mu \frac{d\sigma_2}{dr} + \mu \frac{dp}{dr} \right)$$

(Cancelling  $E$  to both sides)

$$\begin{aligned} \text{or} \quad 0 &= p + \mu\sigma_1 + \mu\sigma_2 + \sigma_1 - \mu\sigma_2 + \mu p + r \left( \frac{d\sigma_1}{dr} - \mu \frac{d\sigma_2}{dr} + \mu \frac{dp}{dr} \right) \\ &= p(1 + \mu) + \sigma_1(1 + \mu) + r \left( \frac{d\sigma_1}{dr} - \mu \frac{d\sigma_2}{dr} + \mu \frac{dp}{dr} \right) \\ &= (p + \sigma_1)(1 + \mu) + r \left( \frac{d\sigma_1}{dr} - \mu \frac{d\sigma_2}{dr} + \mu \frac{dp}{dr} \right) \quad \dots(ix) \end{aligned}$$

To find the value of  $\sigma_1$  in terms of  $p$ , the value of  $\frac{d\sigma_2}{dr}$  must be substituted in the above equation (ix).

Longitudinal strain ( $e_2$ ) is given by equation (iv) as

$$e_2 = \frac{\sigma_2}{E} - \frac{\mu\sigma_1}{E} + \frac{\mu p}{E}$$

Since longitudinal strain ( $e_2$ ) is assumed constant. Its differentiation with respect to  $r$  will be zero. Differentiating the above equation with respect to 'r', we get

$$0 = \frac{1}{E} \left( \frac{d\sigma_2}{dr} - \mu \frac{d\sigma_1}{dr} + \frac{\mu dp}{dr} \right) \quad \left( \because \frac{de_2}{dr} = 0 \right)$$

$$\text{or} \quad 0 = \frac{d\sigma_2}{dr} - \mu \frac{d\sigma_1}{dr} + \mu \frac{dp}{dr}$$

$$\text{or} \quad \frac{d\sigma_2}{dr} = \mu \frac{d\sigma_1}{dr} - \mu \frac{dp}{dr}$$

Substituting the value of  $\frac{d\sigma_2}{dr}$  in equation (ix), we get

$$\begin{aligned} 0 &= (p + \sigma_1)(1 + \mu) + r \left[ \frac{d\sigma_1}{dr} - \mu \left( \mu \frac{d\sigma_1}{dr} - \mu \frac{dp}{dr} \right) + \mu \frac{dp}{dr} \right] \\ &= (p + \sigma_1)(1 + \mu) + r \left[ \frac{d\sigma_1}{dr} (1 - \mu^2) + \mu \frac{dp}{dr} (1 + \mu) \right] \\ &= (p + \sigma_1)(1 + \mu) + r(1 - \mu^2) \frac{d\sigma_1}{dr} + \mu r(1 + \mu) \frac{dp}{dr} \\ &= (p + \sigma_1)(1 + \mu) + r(1 + \mu)(1 - \mu) \frac{d\sigma_1}{dr} + \mu r(1 + \mu) \frac{dp}{dr} \\ &= (1 + \mu) \left[ (p + \sigma_1) + r(1 - \mu) \frac{d\sigma_1}{dr} + \mu r \frac{dp}{dr} \right] \quad [\because (1 + \mu) \neq 0] \end{aligned}$$

$$\text{or} \quad 0 = (p + \sigma_1) + r(1 - \mu) \frac{d\sigma_1}{dr} + \mu r \frac{dp}{dr} \quad \dots(x)$$

For the equilibrium of the element, resolving the forces acting on the element in the radial direction we get [Refer to Fig. 18.2 (c)],

$$(p + dp)(r + dr) \delta\theta - p \times r \times \delta\theta + 2\sigma_1 \times dr \times \sin \frac{\delta\theta}{2} = 0$$

As  $\delta\theta$  is small, hence  $\sin \frac{\delta\theta}{2} \approx \frac{\delta\theta}{2}$ . Now the above equation becomes



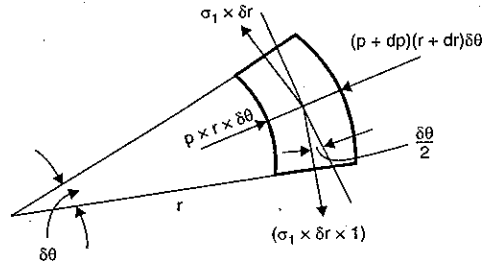

Fig. 18.2 (c)

$$(p + dp)(r + dr) \delta\theta - pr\delta\theta + 2\sigma_1 \times dr \times \frac{\delta\theta}{2} = 0$$

$$\text{or } (p + dp)(r + dr) - pr + \sigma_1 \times dr = 0 \quad [\text{Cancelling } \delta\theta \text{ to both sides}]$$

$$\text{or } pr + pdr + rdp + dp \times dr - pr + \sigma_1 \times dr = 0$$

$$\text{or } pdr + rdp + \sigma_1 dr = 0$$

[ $dp \times dr$  is the product of two small quantities and can be neglected]

$$\text{or } p + r \frac{dp}{dr} + \sigma_1 = 0 \quad \text{or } p + \sigma_1 = -r \frac{dp}{dr} \quad \dots(x)$$

Substituting the value of  $(p + \sigma_1)$  in equation (x), we get

$$0 = -r \frac{dp}{dr} + r(1 - \mu) \frac{d\sigma_1}{dr} + \mu r \frac{dp}{dr}$$

$$0 = -r \frac{dp}{dr} (1 - \mu) + r(1 - \mu) \frac{d\sigma_1}{dr}$$

$$\text{or } 0 = -\frac{dp}{dr} + \frac{d\sigma_1}{dr} \quad [\text{Cancelling } r(1 - \mu) \text{ to both sides}]$$

$$\text{or } \frac{d\sigma_1}{dr} - \frac{dp}{dr} = 0$$

Integrating, we get

$$\sigma_1 - p = \text{constant} = 2a \quad (\text{let the constant} = 2a) \quad \dots(xii)$$

In equations (xii) and (xi), the two unknown are  $\sigma_1$  and  $p$ . Let us find the value of  $\sigma_1$  from equation (xii) and substitute this value in equation (xi).

From equation (xii),  $\sigma_1 = 2a + p$

Substituting this value of  $\sigma_1$  in equation (xi), we get

$$p + (2a + p) = -r \frac{dp}{dr}$$

$$\text{or } 2p + 2a = -r \frac{dp}{dr} \quad \text{or } 2p + r \frac{dp}{dr} = -2a$$

$$\text{or } \frac{1}{r} \frac{d(pr^2)}{dr} = -2a \quad \text{or } \frac{d}{dr} (pr^2) = -2ar$$

Integrating, we get

$$pr^2 = \frac{-2ar^2}{2} + b \quad \text{where } b \text{ is another constant.}$$

$$= -ar^2 + b$$

$$\text{or } p = \frac{-ar^2}{r^2} + \frac{b}{r^2} \quad \text{or } p = \frac{b}{r^2} - a \quad \dots(xiii)$$

The above equation gives the radial pressure at radius ' $r$ '. This equation is same as equation (18.1). To find the value of  $\sigma_1$  at any radius, substitute this value of  $p$  in equation (xiii).

$$\therefore \sigma_1 - \left( \frac{b}{r^2} - a \right) = 2a \quad \text{or } \sigma_1 - \frac{b}{r^2} + a = 2a$$

$$\text{or } \sigma_1 = \frac{b}{r^2} + 2a - a = \frac{b}{r^2} + a \quad \dots(xiv)$$

The above equation gives the circumferential stress (or hoop stress) at any radius  $r$ . This equation is same as equation (18.2).

**Problem 18.1.** Determine the maximum and minimum hoop stress across the section of a pipe of 400 mm internal diameter and 100 mm thick, when the pipe contains a fluid at a pressure of 8 N/mm<sup>2</sup>. Also sketch the radial pressure distribution and hoop stress distribution across the section. (Annamalai University, 1991)

**Sol.** Given :

$$\text{Internal dia.} = 400 \text{ mm}$$

$$\therefore \text{Internal radius, } r_1 = \frac{400}{2} = 200 \text{ mm}$$

$$\text{Thickness} = 100 \text{ mm}$$

$$\therefore \text{External dia.} = 400 + 2 \times 100 = 600 \text{ mm}$$

$$\therefore \text{External radius, } r_2 = \frac{600}{2} = 300 \text{ mm}$$

$$\text{Fluid pressure, } p_0 = 8 \text{ N/mm}^2$$

$$\text{or } \text{at } x = r_1, p_x = p_0 = 8 \text{ N/mm}^2$$

The radial pressure ( $p_x$ ) is given by equation (18.1) as

$$p_x = \frac{b}{x^2} - a \quad \dots(i)$$

Now apply the boundary conditions to the above equations. The boundary conditions are :

$$1. \text{ At } x = r_1 = 200 \text{ mm, } p_x = 8 \text{ N/mm}^2$$

$$2. \text{ At } x = r_2 = 300 \text{ mm, } p_x = 0$$

Substituting these boundary conditions in equation (i), we get

$$8 = \frac{b}{200^2} - a = \frac{b}{40000} - a \quad \dots(ii)$$

$$\text{and } 0 = \frac{b}{300^2} - a = \frac{b}{90000} - a \quad \dots(iii)$$

Subtracting equation (iii) from equation (ii), we get

$$8 = \frac{b}{40000} - \frac{b}{90000} = \frac{9b - 4b}{360000} = \frac{5b}{360000}$$

$$\therefore b = \frac{360000 \times 8}{5} = 576000$$

Substituting this value in equation (iii), we get

$$0 = \frac{576000}{90000} - a \quad \text{or} \quad a = \frac{576000}{90000} = 6.4$$

The values of 'a' and 'b' are substituted in the hoop stress.

Now hoop stress at any radius  $x$  is given by equation (18.2) as

$$\sigma_x = \frac{b}{x^2} + a = \frac{576000}{x^2} + 6.4$$

$$\text{At } x = 200 \text{ mm, } \sigma_{200} = \frac{576000}{200^2} + 6.4 = 14.4 + 6.4 = 20.8 \text{ N/mm}^2. \quad \text{Ans.}$$

$$\text{At } x = 300 \text{ mm, } \sigma_{300} = \frac{576000}{300^2} + 6.4 = 6.4 + 6.4 = 12.8 \text{ N/mm}^2. \quad \text{Ans.}$$

Fig. 18.3 shows the radial pressure distribution and hoop stress distribution across the section.  $AB$  is taken a horizontal line.  $AC = 8 \text{ N/mm}^2$ . The variation between  $B$  and  $C$  is parabolic. The curve  $BC$  shows the variation of radial pressure across  $AB$ .

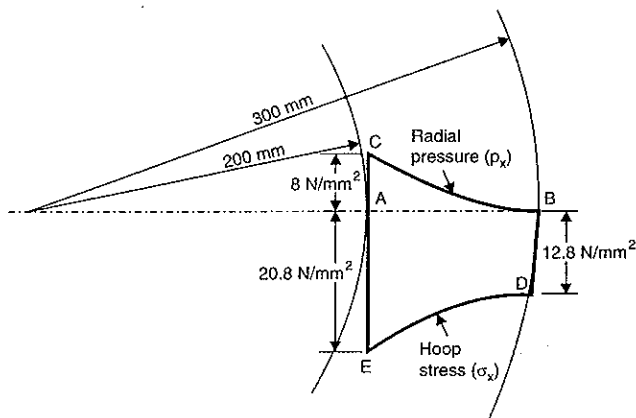

Fig. 18.3

The curve  $DE$  which is also parabolic, shows the variation of hoop stress across  $AB$ . Values  $BD = 12.8 \text{ N/mm}^2$  and  $AE = 20.8 \text{ N/mm}^2$ . The radial pressure is compressive whereas the hoop stress is tensile.

**Problem 18.2.** Find the thickness of metal necessary for a cylindrical shell of internal diameter 160 mm to withstand an internal pressure of  $8 \text{ N/mm}^2$ . The maximum hoop stress in the section is not to exceed  $35 \text{ N/mm}^2$ .

**Sol.** Given :

Internal dia. = 160 mm

∴ Internal radius,  $r_1 = \frac{160}{2} = 80 \text{ mm}$

Internal pressure =  $8 \text{ N/mm}^2$

This means at  $x = 80 \text{ mm}$ ,  $p_x = 8 \text{ N/mm}^2$

Maximum hoop stress,  $\sigma_x = 35 \text{ N/mm}^2$

The maximum hoop stress is at the inner radius of the shell.

Let  $r_2 =$  External radius.

The radial pressure and hoop stress at any radius  $x$  are given by equations (18.1) and (18.2) is

$$p_x = \frac{b}{x^2} - a \quad \dots(i)$$

and

$$\sigma_x = \frac{b}{x^2} + a \quad \dots(ii)$$

Let us now apply the boundary conditions. The boundary conditions are :

at  $x = 80 \text{ mm}$ ,  $p_x = 8 \text{ N/mm}^2$  and  $\sigma_x = 35 \text{ N/mm}^2$

Substituting  $x = 80 \text{ mm}$  and  $p_x = 8 \text{ N/mm}^2$  in equation (i), we get

$$8 = \frac{b}{80^2} - a = \frac{b}{6400} - a \quad \dots(iii)$$

Substituting  $x = 80 \text{ mm}$  and  $\sigma_x = 35 \text{ N/mm}^2$  in equation (ii), we get

$$35 = \frac{b}{80^2} + a = \frac{b}{6400} + a \quad \dots(iv)$$

Subtracting equation (iii) from equation (iv), we get

$$27 = 2a \quad \text{or} \quad a = \frac{27}{2} = 13.5$$

Substituting the value of  $a$  in equation (iii), we get

$$8 = \frac{b}{6400} - 13.5$$

or

$$b = (8 + 13.5) \times 6400 = 21.5 \times 6400$$

Substituting the values of 'a' and 'b' in equation (i),

$$p_x = \frac{21.5 \times 6400}{x^2} - 13.5$$

But at the outer surface, the pressure is zero. Hence at  $x = r_2$ ,  $p_x = 0$ . Substituting these values in the above equation, we get

$$0 = \frac{21.5 \times 6400}{r_2^2} - 13.5$$

or

$$r_2^2 = \frac{21.5 \times 6400}{13.5} \quad \text{or} \quad r_2 = \sqrt{\frac{21.5 \times 6400}{13.5}} = 100.96 \text{ mm}$$

∴ Thickness of the shell,  $t = r_2 - r_1$

$$= 100.96 - 80 = 20.96 \text{ mm.} \quad \text{Ans.}$$

### 18.3. STRESSES IN COMPOUND THICK CYLINDERS

From problem 18.1, we find that the hoop stress is maximum at the inner radius and it decreases towards the outer radius. The hoop stress is tensile in nature and it is caused by the internal fluid pressure inside the cylinder. This maximum hoop stress at the inner radius is always greater than the internal fluid pressure. Hence the maximum fluid pressure inside the cylinder is limited corresponding to the condition that the hoop stress at the inner radius reaches the permissible value. In case of cylinders which have to carry high internal fluid pressures, some methods of reducing the hoop stress have to be devised.

One method is to wind\* strong steel wire under tension on the cylinder. The effect of the wire is to put the cylinder wall under an initial compressive stress.

Another method is to shrink one cylinder over the other. Due to this, the inner cylinder will be put into initial compression whereas the outer cylinder will be put into initial tension. If now the compound cylinder is subjected to internal fluid pressure, both the inner and outer cylinders will be subjected to hoop tensile stress. The net effect of the initial stresses due to shrinking and those due to internal fluid pressure is to make the resultant stresses more or less uniform.

Fig. 18.4 shows a compound thick cylinder made up of two cylinders.

Let  $r_2$  = Outer radius of compound cylinder

$r_1$  = Inner radius of compound cylinder

$r^*$  = Radius at the junction of the two cylinders  
(i.e., outer radius of inner cylinder or inner radius of outer cylinder)

$p^*$  = Radial pressure at the junction of the two cylinders.

Let us now apply Lamé's equation i.e., equations (18.1) and (18.2) for the initial conditions i.e., after shrinking the outer cylinder over the inner cylinder and fluid under pressure is not admitted into the inner cylinder).

(i) For outer cylinder

The Lamé's equations at a radius  $x$  for outer cylinder are given by

$$p_x = \frac{b_1}{x^2} - a_1 \quad \dots(i) \quad \sigma_x = \frac{b_1}{x^2} + a_1 \quad \dots(ii)$$

where  $a_1, b_1$  are constants for outer cylinder.

At  $x = r_2, p_x = 0$ . And at  $x = r^*, p_x = p^*$

Substituting these conditions in equation (i), we get

$$0 = \frac{b_1}{r_2^2} - a_1 \quad \dots(iii) \quad p^* = \frac{b_1}{r^{*2}} - a_1 \quad \dots(iv)$$

From equations (iii) and (iv), the constants  $a_1$  and  $b_1$  can be determined. These values are substituted in equation (ii). And then hoop stresses in the outer cylinder due to shrinking can be obtained.

(ii) For inner cylinder

The Lamé's equations for inner cylinder at a radius  $x$  are given by

$$p_x = \frac{b_2}{x^2} - a_2, \quad \sigma_x = \frac{b_2}{x^2} + a_2$$

where  $a_2, b_2$  are constants for inner cylinder.

At  $x = r_1, p_x = 0$  as fluid under pressure is not admitted into the inner cylinder. And at  $x = r^*, p_x = p^*$ .

Substituting these values in the above value of  $p_x$ , we get

$$0 = \frac{b_2}{r_1^2} - a_2 \quad \dots(v) \quad \text{and} \quad p^* = \frac{b_2}{r^{*2}} - a_2 \quad \dots(vi)$$

\* This method has already been explained in chapter 17 on page 765.

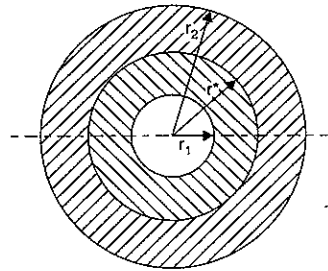

Fig. 18.4

From equations (v) and (vi), the constants  $a_2$  and  $b_2$  can be determined. These values are substituted in  $\sigma_x$ . And then hoop stresses are obtained.

### Hoop stresses in compound cylinder due to internal fluid pressure alone

When the fluid under pressure is admitted into the compound cylinder, the hoop stresses are set in the compound cylinder. To find these stresses, the inner cylinder and outer cylinder will together will be considered as one thick shell. Let  $p$  = internal fluid pressure. Now the Lamé's equations are applied, which are given by

$$p_x = \frac{B}{x^2} - A \quad \dots(vii) \quad \text{and} \quad \sigma_x = \frac{B}{x^2} + A \quad \dots(viii)$$

where  $A$  and  $B$  are constants for single thick shell due to internal fluid pressure.

At  $x = r_2, p_x = 0$ .

Substituting these values in equation (vii), we get

$$0 = \frac{B}{r_2^2} - A \quad \dots(ix)$$

At  $x = r_1, p_x = p$ .

Substituting these values in equation (vii), we get

$$p = \frac{B}{r_1^2} - A \quad \dots(x)$$

From equations (ix) and (x), the constants  $A$  and  $B$  can be determined. These values are substituted in equation (viii). And then hoop stresses across the section can be obtained.

The resultant hoop stresses will be the algebraic sum of the hoop stresses caused due to shrinking and those due to internal fluid pressure.

**Problem 18.3.** A compound cylinder is made by shrinking a cylinder of external diameter 300 mm and internal diameter of 250 mm over another cylinder of external diameter 250 mm and internal diameter 200 mm. The radial pressure at the junction after shrinking is 8 N/mm<sup>2</sup>. Find the final stresses set up across the section, when the compound cylinder is subjected to an internal fluid pressure of 84.5 N/mm<sup>2</sup>.

**Sol.** Given :

For outer cylinder :

External diameter = 300 mm

∴ External radius,

$$r_2 = \frac{300}{2} = 150 \text{ mm}$$

Internal diameter = 250 mm

∴ Radius at the junction,

$$r^* = \frac{250}{2} = 125 \text{ mm.}$$

For inner cylinder

Internal diameter = 200 mm

∴ Internal radius

$$r_1 = \frac{200}{2} = 100 \text{ mm}$$

Radial pressure due to shrinking at the junction,

$$p^* = 8 \text{ N/mm}^2$$

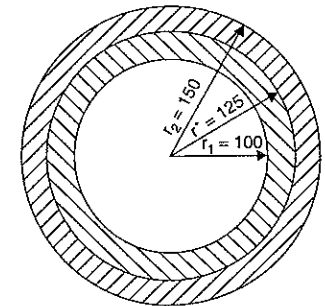

Fig. 18.5

Fluid pressure in the compound cylinder,

$$p = 84.5 \text{ N/mm}^2.$$

(i) Stresses due to shrinking in the outer and inner cylinders before the fluid pressure is admitted.

(a) Lamé's equations for outer cylinders are

$$p_x = \frac{b_1}{x^2} - a_1 \quad \dots(i) \quad \text{and} \quad \sigma_x = \frac{b_1}{x^2} + a_1 \quad \dots(ii)$$

At  $x = 150 \text{ mm}$ ,  $p_x = 0$ .

Substituting these values in equation (i),

$$0 = \frac{b_1}{150^2} - a_1 = \frac{b_1}{22500} - a_1 \quad \dots(iii)$$

At  $x = r^* = 125 \text{ mm}$ ,  $p_x = p^* = 8 \text{ N/mm}^2$ .

Substituting these values in equation (i), we get

$$8 = \frac{b_1}{125^2} - a_1 = \frac{b_1}{15625} - a_1 \quad \dots(iv)$$

Subtracting equation (iii) from equation (iv), we get

$$8 = -\frac{b_1}{22500} + \frac{b_1}{15625} = \frac{(-15625 + 22500) b_1}{22500 \times 15625}$$

$$\therefore b_1 = \frac{8 \times 22500 \times 15625}{(-15625 + 22500)} = 409090.9$$

Substituting the value of  $b_1$  in equation (iii), we get

$$0 = \frac{409090.9}{22500} - a_1 \quad \text{or} \quad a_1 = \frac{409090.9}{22500} = 18.18$$

Substituting the values of  $a_1$  and  $b_1$  in equation (ii), we get

$$\sigma_x = \frac{409090.9}{x^2} + 18.18$$

The above equation gives the hoop stress in the outer cylinder due to shrinking. The hoop stress at the outer and inner surface of the outer cylinder is obtained by substituting  $x = 150 \text{ mm}$  and  $x = 125 \text{ mm}$  respectively in the above equation.

$$\sigma_{150} = \frac{409090.9}{150^2} + 18.18 = 36.36 \text{ N/mm}^2 \text{ (tensile)}$$

$$\text{and} \quad \sigma_{125} = \frac{409090.9}{125^2} + 18.18 = 44.36 \text{ N/mm}^2 \text{ (tensile).}$$

(b) Lamé's equations for the inner cylinder are :

$$p_x = \frac{b_2}{x^2} - a_2 \quad \dots(v) \quad \text{and} \quad \sigma_x = \frac{b_2}{x^2} + a_2 \quad \dots(vi)$$

At  $x = r_1 = 100 \text{ mm}$ ,  $p_x = 0$  (There is no fluid under pressure.)

Substituting these values in equation (v), we get

$$0 = \frac{b_2}{100^2} - a_2 = \frac{b_2}{10000} - a_2 \quad \dots(vii)$$

At  $x = r^* = 125 \text{ mm}$ ,  $p_x = p^* = 8 \text{ N/mm}^2$ . Substituting these values in equation (v), we get

$$8 = \frac{b_2}{125^2} - a_2 = \frac{b_2}{15625} - a_2 \quad \dots(viii)$$

Subtracting equation (vii) from equation (viii), we get

$$8 = \frac{b_2}{15625} - \frac{b_2}{10000} \\ = \frac{b_2(10000 - 15625)}{15625 \times 10000} = \frac{-5625 b_2}{15625 \times 10000}$$

$$\therefore b_2 = \frac{8 \times 15625 \times 10000}{5625} = -222222.2$$

Substituting the value  $b_2$  in equation (vii), we get

$$0 = -\frac{222222.2}{10000} - a_2$$

or

$$a_2 = -22.22$$

Substituting the values of  $a_2$  and  $b_2$  in equation (vi), we get

$$\sigma_x = -\frac{222222.2}{x^2} - 22.22$$

Hence the hoop stress for the inner cylinder is obtained by substituting  $x = 125 \text{ mm}$  respectively in the above equation.

$$\therefore \sigma_{125} = -\frac{222222.2}{125^2} - 22.22 \\ = -14.22 - 22.22 = -36.22 \text{ N/mm}^2 \text{ (compressive)}$$

and

$$\sigma_{100} = -\frac{222222.2}{100^2} - 22.22 \\ = -22.22 - 22.22 = -44.44 \text{ N/mm}^2 \text{ (compressive)}$$

(ii) Stresses due to fluid pressure alone

When the fluid under pressure is admitted inside the compound cylinder, the two cylinders together will be considered as one single unit. The hoop stresses are calculated by Lamé's equations, which are

$$p_x = \frac{B}{x^2} - A \quad \dots(ix) \quad \text{and} \quad \sigma_x = \frac{B}{x^2} + A \quad \dots(x)$$

where  $A$  and  $B$  are constants.

At  $x = 100 \text{ mm}$ ,  $p_x = p = 84.5 \text{ N/mm}^2$ . Substituting the values in equation (ix), we get

$$84.5 = \frac{B}{100^2} - A = \frac{B}{10000} - A \quad \dots(xi)$$

At  $x = 150 \text{ mm}$ ,  $p_x = 0$ . Substituting these values in equation (ix), we get

$$0 = \frac{B}{150^2} - A = \frac{B}{22500} - A \quad \dots(xii)$$

Subtracting equation (xii) from equation (xi), we get

$$84.5 = \frac{B}{10000} - \frac{B}{22500} \\ = \frac{B(22500 - 10000)}{10000 \times 22500} = \frac{12500 \times B}{10000 \times 22500} \\ B = \frac{84.5 \times 10000 \times 22500}{12500} = 1521000$$

Substituting this values in equation (xii), we get

$$0 = \frac{1521000}{22500} - A \quad \text{or} \quad A = \frac{1521000}{22500} = 67.6$$

Substituting the values of  $A$  and  $B$  in equation (x), we get

$$\sigma_x = \frac{1521000}{x^2} + 67.6$$

Hence the hoop stresses due to internal fluid pressure alone are given by,

$$\sigma_{100} = \frac{1521000}{100^2} + 67.6 = 219.7 \text{ N/mm}^2 \text{ (tensile)}$$

$$\begin{aligned} \sigma_{125} &= \frac{1521000}{125^2} + 67.6 = 97.344 + 67.6 \\ &= 164.94 \text{ N/mm}^2 \end{aligned}$$

$$\sigma_{150} = \frac{1521000}{150^2} + 67.6 = 67.6 + 67.6 = 135.2 \text{ N/mm}^2.$$

The resultant stresses will be the algebraic sum of the initial stresses due to shrinking and those due to internal fluid pressure.

*Inner cylinder*

$$\begin{aligned} F_{100} &= \sigma_{100} \text{ due to shrinkage} + \sigma_{100} \text{ due to internal fluid pressure} \\ &= -44.44 + 219.7 = 175.26 \text{ N/mm}^2 \text{ (tensile). Ans.} \end{aligned}$$

$$\begin{aligned} F_{125} &= \sigma_{125} \text{ due to shrinkage} + \sigma_{125} \text{ due to internal fluid pressure} \\ &= -36.22 + 164.94 = 128.72 \text{ N/mm}^2 \text{ (tensile). Ans.} \end{aligned}$$

*Outer cylinder*

$$\begin{aligned} F_{125} &= \sigma_{125} \text{ due to shrinkage} + \sigma_{125} \text{ due to internal fluid pressure} \\ &= 44.36 + 164.94 = 209.3 \text{ N/mm}^2 \text{ (tensile). Ans.} \end{aligned}$$

$$\begin{aligned} F_{150} &= \sigma_{150} \text{ due to shrinkage} + \sigma_{150} \text{ due to internal fluid pressure} \\ &= 36.36 + 135.2 = 171.56 \text{ N/mm}^2 \text{ (tensile). Ans.} \end{aligned}$$

#### 18.4. INITIAL DIFFERENCE IN RADII AT THE JUNCTION OF A COMPOUND CYLINDER FOR SHRINKAGE

By shrinking the outer cylinder over the inner cylinder, some compressive stresses are produced in the inner cylinder. In order to shrink the outer cylinder over the inner cylinder, the inner diameter of the outer cylinder should be slightly less than the outer diameter of the inner cylinder. Now the outer cylinder is heated and inner cylinder is inserted into it. After cooling, the outer cylinder shrinks over the inner cylinder. Thus inner cylinder is put into compression and outer cylinder is put into tension. After shrinking the outer radius of inner cylinder decreases whereas the inner radius of outer cylinder increases from the initial values.

Let  $r_2$  = Outer radius of the outer cylinder

$r_1$  = Inner radius of the inner cylinder

$r^*$  = Radius of junction after shrinking or it is common radius after shrinking

$p^*$  = Radial pressure at the junction after shrinking.

Before shrinking the outer radius of the inner cylinder is slightly more than  $r^*$  and inner radius of the outer cylinder is slightly less than  $r^*$ .

For the outer and inner cylinder Lamé's equations are used. These equations are

$$p_x = \frac{b}{x^2} - a \quad \text{and} \quad \sigma_x = \frac{b}{x^2} + a$$

The values of constants  $a$  and  $b$  will be different for each cylinder.

Let the constants for inner cylinder be  $a_2, b_2$  and for outer cylinder  $a_1, b_1$ .

The radial pressure at the junction (i.e.,  $p^*$ ) is same for outer cylinder and inner cylinder.

At the junction,  $x = r^*$  and  $p_x = p^*$ . Hence radial pressure at the junction.

$$p^* = \frac{b_1}{r^{*2}} - a_1 = \frac{b_2}{r^{*2}} - a_2 \quad \dots(A)$$

$$\text{or} \quad \frac{b_1 - b_2}{r^{*2}} = (a_1 - a_2) \quad \dots(B)$$

or  $(b_1 - b_2) = r^{*2} (a_1 - a_2)$   
Now the hoop strain (or circumferential strain) in the cylinders at any point

$$= \frac{\sigma_x}{E} + \frac{p_x}{mE} \quad \dots(C)$$

But circumferential strain

$$\begin{aligned} &= \frac{\text{Increase in circumference}}{\text{Original circumference}} \\ &= \frac{2\pi(r + dr) - 2\pi r}{2\pi r} = \frac{dr}{r} \quad \dots(D) \\ &= \text{Radial strain} \end{aligned}$$

Hence equating the two values of circumferential strain given by equations (C) and (D), we get

$$\frac{dr}{r} = \frac{\sigma_x}{E} + \frac{p_x}{mE} \quad \dots(i)$$

On shrinking, at the junction there is extension in the inner radius of the outer cylinder and compression in the outer radius of the inner cylinder.

At the junction where  $x = r^*$ , increase in the inner radius of outer cylinder

$$= r^* \left( \frac{\sigma_x}{E} + \frac{p_x}{mE} \right) \quad \dots(ii)$$

But for outer cylinder at the junction, we have

$$\sigma_x = \frac{b_1}{r^{*2}} + a_1 \quad \text{and} \quad p_x = \frac{b_1}{r^{*2}} - a_1$$

where  $a_1$  and  $b_1$  are constants for outer cylinders.

Substituting the values of  $\sigma_x$  and  $p_x$  in equation (ii), we get

Increase in the inner radius of outer cylinder

$$= r^* \left[ \frac{1}{E} \left( \sigma_x + \frac{p_x}{m} \right) \right] = r^* \left[ \frac{1}{E} \left( \frac{b_1}{r^{*2}} + a_1 \right) + \frac{1}{mE} \left( \frac{b_1}{r^{*2}} - a_1 \right) \right]$$

Similarly, decrease in the outer radius of the inner cylinder is obtained from equation

(i) as

$$= -r^* \left[ \frac{\sigma_x}{E} + \frac{p_x}{mE} \right] \quad (- \text{ve sign is due to decrease}) \quad \dots(iii)$$

But for inner cylinder at the junction, we have

$$\sigma_x = \frac{b_2}{r^{*2}} + a_2 \quad \text{and} \quad p_x = \frac{b_2}{r^{*2}} - a_2$$

Substituting these values in equation (iii), we get

Decrease in the outer radius of inner cylinder

$$= -r^* \left[ \frac{1}{E} \left( \frac{b_2}{r^{*2}} + a_2 \right) + \frac{1}{mE} \left( \frac{b_2}{r^{*2}} - a_2 \right) \right] \quad \dots(iv)$$

But the original difference in the outer radius of the inner cylinder and inner radius of the outer cylinder.

= Increase in inner radius of outer cylinder

+ Decrease in outer radius of the inner cylinder

$$\begin{aligned} &= r^* \left[ \frac{1}{E} \left( \frac{b_1}{r^{*2}} + a_1 \right) + \frac{1}{mE} \left( \frac{b_1}{r^{*2}} - a_1 \right) \right] - r^* \left[ \frac{1}{E} \left( \frac{b_2}{r^{*2}} + a_2 \right) + \frac{1}{mE} \left( \frac{b_2}{r^{*2}} - a_2 \right) \right] \\ &= \frac{r^*}{E} \left[ \left( \frac{b_1}{r^{*2}} + a_1 \right) - \left( \frac{b_2}{r^{*2}} + a_2 \right) \right] + \frac{r^*}{mE} \left[ \left( \frac{b_1}{r^{*2}} - a_1 \right) - \left( \frac{b_2}{r^{*2}} - a_2 \right) \right] \end{aligned}$$

But from equation (A),

$$\frac{b_1}{r^{*2}} - a_1 = \frac{b_2}{r^{*2}} - a_2.$$

Hence second part of the above equation is zero. Hence above equation becomes as

Original difference of radii at the junction

$$\begin{aligned} &= \frac{r^*}{E} \left[ \left( \frac{b_1}{r^{*2}} + a_1 \right) - \left( \frac{b_2}{r^{*2}} + a_2 \right) \right] \\ &= \frac{r^*}{E} \left[ \frac{(b_1 - b_2)}{r^{*2}} + (a_1 - a_2) \right] \\ &= \frac{r^*}{E} [(a_1 - a_2) + (a_1 - a_2)] \quad \left[ \because \text{From equation (B), } \frac{b_1 - b_2}{r^{*2}} = a_1 - a_2 \right] \\ &= \frac{2r^*}{E} (a_1 - a_2) \quad \dots(18.3) \end{aligned}$$

The values of  $a_1$  and  $a_2$  are obtained from the given conditions. The value of  $a_1$  is for outer cylinder whereas of  $a_2$  is for inner cylinder.

**Problem 18.4.** A steel cylinder of 300 mm external diameter is to be shrunk to another steel cylinder of 150 mm internal diameter. After shrinking the diameter at the junction is 120 mm and radial pressure at the common junction is 28 N/mm<sup>2</sup>. Find the original difference in radii at the junction. Take  $E = 2 \times 10^5$  N/mm<sup>2</sup>.

**Sol.** Given :

External dia. of outer cylinder = 300 mm

$\therefore$  Radius,  $r_2 = 150$  mm

Internal dia. of inner cylinder = 150 mm

$\therefore$  Radius,  $r_1 = 75$  mm

Diameter at the junction = 250 mm

$\therefore$  Radius,  $r^* = 125$  mm

Radial pressure at the junction,  $p^* = 28$  N/mm<sup>2</sup>

Value of  $E = 2 \times 10^5$  N/mm<sup>2</sup>

Using equation (18.3), we get

Original difference of radii at the junction

$$= \frac{2r^*}{E} (a_1 - a_2) \quad \dots(i)$$

First find the values of  $a_1$  and  $a_2$  from the given conditions. These are the constants for outer cylinder and inner cylinder respectively. They are obtained by using Lamé's equations.

For outer cylinder

$$p_x = \frac{b_1}{x^2} - a_1$$

(i) At junction,  $x = r^* = 125$  mm and  $p_x = p^* = 28$  N/mm<sup>2</sup>

(ii) At  $x = 150$  mm,  $p_x = 0$ .

Substituting these two conditions in the above equation, we get

$$28 = \frac{b_1}{125^2} - a_1 = \frac{b_1}{15625} - a_1 \quad \dots(ii)$$

and

$$0 = \frac{b_1}{150^2} - a_1 = \frac{b_1}{22500} - a_1 \quad \dots(iii)$$

Solving equations (ii) and (iii), we get

$$b_1 = 1432000 \quad \text{and} \quad a_1 = 63.6.$$

For inner cylinder

$$p_x = \frac{b_2}{x^2} - a_2$$

(i) At junction,  $x = r^* = 125$  mm and  $p_x = p^* = 28$  N/mm<sup>2</sup>

(ii) At  $x = 75$  mm,  $p_x = 0$ .

Substituting these two conditions in the above equation, we get

$$28 = \frac{b_2}{125^2} - a_2 = \frac{b_2}{15625} - a_2 \quad \dots(iv)$$

and

$$0 = \frac{b_2}{75^2} - a_2 = \frac{b_2}{5625} - a_2 \quad \dots(v)$$

Solving equations (iv) and (v), we get

$$b_2 = -246100$$

and

$$a_2 = -43.75$$

Now substituting the values of  $a_2$  and  $a_1$  in equation (i), we get

Difference of radii at the junction

$$\begin{aligned} &= \frac{2 \times 125}{2 \times 10^5} [63.6 - (-43.75)] \\ &= \frac{125}{10^5} \times 107.35 = 0.13 \text{ mm. Ans.} \end{aligned}$$

**Problem 18.5.** A steel tube of 200 mm external diameter is to be shrunk on to another steel tube of 60 mm internal diameter. The diameter at the junction after shrinking is 120 mm.

Before shrinking on, the difference of diameters at the junction is 0.08 mm. Calculate the radial pressure at the junction and the hoop stresses developed in the two tubes after shrinking on. Take  $E$  as  $2 \times 10^5 \text{ N/mm}^2$ .

**Sol.** Given :

External dia. of outer tube = 200 mm

∴ Radius,  $r_2 = 100 \text{ mm}$

Internal dia. of inner tube = 60 mm

∴ Radius,  $r_1 = 30 \text{ mm}$

The diameter at the junction after shrinking = 120 mm

∴ Radius,  $r^* = 60 \text{ mm}$

Before shrinking on the difference of dia. at the junction = 0.08 mm

∴ Difference of original radii = 0.04 mm

Value of  $E = 2 \times 10^5 \text{ N/mm}^2$

Let  $p^*$  = Radial pressure at the junction

Using equation (19.3),

Original difference of radii at junction

$$= \frac{2r^*}{E} (a_1 - a_2)$$

$$\text{or } 0.04 = \frac{2 \times 60}{2 \times 10^5} (a_1 - a_2) \quad \text{or} \quad \frac{0.04 \times 2 \times 10^5}{2 \times 60} = (a_1 - a_2)$$

$$\text{or } (a_1 - a_2) = \frac{200}{3} \quad \dots(i)$$

Now using Lamé's equation for outer tube

$$p_x = \frac{b_1}{x^2} - a_1 \quad \dots(ii) \quad \text{and} \quad \sigma_x = \frac{b_1}{x^2} + a_1 \quad \dots(iii)$$

At  $x = 100 \text{ mm}$ ,  $p_x = 0$ .

Substituting these values in equation (ii),

$$0 = \frac{b_1}{100^2} - a_1 = \frac{b_1}{10000} - a_1 \quad \dots(iv)$$

At  $x = 60 \text{ mm}$ ,  $p_x = p^*$ .

Substituting these values in equation (ii),

$$p^* = \frac{b_1}{60^2} - a_1 = \frac{b_1}{3600} - a_1 \quad \dots(v)$$

Now applying Lamé's equation for inner tube

$$p_x = \frac{b_2}{x^2} - a_2 \quad \dots(vi) \quad \text{and} \quad \sigma_x = \frac{b_2}{x^2} + a_2 \quad \dots(vii)$$

At  $x = 30 \text{ mm}$ ,  $p_x = 0$ .

Substituting these values in equation (vi),

$$0 = \frac{b_2}{30^2} - a_2 = \frac{b_2}{900} - a_2 \quad \dots(viii)$$

At  $x = 60 \text{ mm}$ ,  $p_x = p^*$ .

Substituting these values in equation (vi),

$$p^* = \frac{b_2}{60^2} - a_2 = \frac{b_2}{3600} - a_2 \quad \dots(ix)$$

Equating the two values of  $p^*$ , given by equations (v) and (ix), we get

$$\frac{b_2}{3600} - a_2 = \frac{b_1}{3600} - a_1$$

$$\text{or } \frac{b_2 - b_1}{3600} = a_2 - a_1 \quad \dots(x)$$

But from equation (iv),  $b_1 = 10000 a_1$

and, from equation (viii),  $b_2 = 900 a_2$

Substituting these values in equation (x), we get

$$\frac{900 a_2 - 10000 a_1}{3600} = a_2 - a_1$$

$$\text{or } 900 a_2 - 10000 a_1 = 3600 a_2 - 3600 a_1$$

$$\text{or } 900 a_2 - 3600 a_2 = -3600 a_1 + 10000 a_1$$

$$\text{or } -2700 a_2 = 6400 a_1$$

$$\text{or } a_1 = -\frac{2700}{6400} a_2 = -\frac{27}{64} a_2 \quad \dots(xi)$$

Substituting the value of  $a_1$  in equation (i), we get

$$-\frac{27}{64} a_2 - a_2 = \frac{200}{3}$$

$$\text{or } -\frac{(27 a_2 + 64 a_2)}{64} = \frac{200}{3} \quad \text{or} \quad a_2 = -\frac{200 \times 64}{3 \times 91} = -46.88$$

Substituting this value in equation (xi), we get

$$a_1 = +\frac{27}{64} \times 46.88 = +19.77$$

$$b_1 = 10000 \times a_1 = 10000 \times (19.77) = 197700$$

$$\text{and } b_2 = 900 \times a_2 = -900 \times 46.88 = -42192$$

(i) Radial pressure at the junction ( $p^*$ )

Substituting the values of  $a_2$  and  $b_2$  in equation (ix), we get

$$p^* = \frac{b_2}{3600} - a_2 = -\frac{42192}{3600} + 46.88$$

$$= +35.16 \text{ N/mm}^2. \quad \text{Ans.}$$

The value of  $p^*$  can also be obtained by substituting  $a_1$  and  $b_1$  in equation (v)

$$p^* = \frac{b_1}{3600} - a_1$$

$$= \frac{197700}{3600} - 19.77 = 54.916 - 19.77$$

$$= 35.146 \text{ N/mm}^2. \quad \text{Ans.}$$

(ii) Hoop stresses in the two tubes after shrinking on

The hoop stresses can be calculated from equations (iii) and (vii).

(a) For outer tube

$$\sigma_x = \frac{b_1}{x^2} + a_1 = \frac{197700}{x^2} + 19.77 \quad (\because b_1 = 197700, a_1 = 19.77)$$

$$\sigma_{100} = \frac{197700}{100^2} + 19.77$$

$$= 39.54 \text{ N/mm}^2 \text{ (tensile). Ans.}$$

and

$$\sigma_{60} = \frac{197700}{60^2} + 19.77 = 74.68 \text{ N/mm}^2 \text{ (tensile). Ans.}$$

(b) For inner tube

$$\sigma_x = \frac{b_2}{x^2} + a_2$$

$$= -\frac{42192}{x^2} - 46.88 \quad (\because b_2 = -42192, a_2 = -46.88)$$

$$\sigma_{60} = -\frac{42192}{60^2} - 46.88$$

$$= -58.6 \text{ N/mm}^2 \text{ (compressive). Ans.}$$

and

$$\sigma_{30} = -\frac{42192}{30^2} - 46.88 = -93.76 \text{ N/mm}^2 \text{ (compressive). Ans.}$$

### 18.5. THICK SPHERICAL SHELLS

Fig. 18.6 shows a spherical shell subjected to an internal fluid pressure  $p$ .

Let  $r_2$  = External radius

$r_1$  = Internal radius.

Consider an *elemental disc* of the spherical shell of thickness  $dx$  at a radius  $x$ . Let this elemental disc subtend an angle  $d\theta$  at the centre.

Due to internal fluid pressure, let the radius  $x$  increase to  $(x + u)$  and increase in thickness  $dx$  be  $du$ .

Let  $e_y$  = Circumferential strain and

$e_x$  = Radial strain

Now increase in radius =  $u$

$\therefore$  Final radius =  $x + u$

$\therefore$  Circumferential strain,

$$e_y = \frac{\text{Final circumference} - \text{Original circumference}}{\text{Original circumference}}$$

$$= \frac{2\pi(x + u) - 2\pi x}{2\pi x} = \frac{u}{x} \quad \dots(i)$$

Now original thickness of element =  $dx$

Final thickness of element =  $dx + du$

$\therefore$  Radial strain,

$$e_x = \frac{\text{Final thickness of element} - \text{Original thickness}}{\text{Original thickness}}$$

$$= \frac{(dx + du) - dx}{dx} = \frac{du}{dx} \quad \dots(ii)$$

But from equation (i),

$$u = x \cdot e_y$$

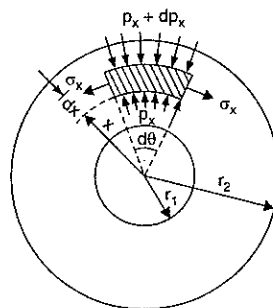

Fig. 18.6

$\therefore$  Radial strain,

$$e_x = \frac{d}{dx} (x \cdot e_y) = e_y + x \cdot \frac{de_y}{dx} \quad \dots(iii)$$

Now consider an *elemental spherical shell* of radius  $x$  and thickness  $dx$  as shown in Fig. 18.7. Let  $p_x$  and  $p_x + dp_x$  be the radial pressures at radii  $x$  and  $x + dx$  respectively. And  $\sigma_x$  is the circumferential tensile stress which is equal in all directions in a spherical shell.

Considering the equilibrium of half of the elementary spherical shell on which the following external forces are acting :

- (i) An upward force of  $\pi x^2 \cdot p_x$  due to internal radial pressure  $p$
- (ii) A downward force of  $\pi(x + dx)^2 \cdot (p_x + dp_x)$  due to radial pressure  $p_x + dp_x$ .
- (iii) A downward resisting force  $\sigma_x (2\pi x \cdot dx)$ .

Equating the upward and downward forces, we get

$$\pi x^2 p_x = \pi(x + dx)^2 \cdot (p_x + dp_x) + 2\pi x \cdot dx \cdot \sigma_x$$

or

$$x^2 \cdot p_x = (x^2 + dx^2 + 2x \cdot dx)(p_x + dp_x) + 2x \cdot dx \cdot \sigma_x$$

$$= (x^2 \cdot p_x + dx^2 \cdot p_x + 2x \cdot dx \cdot p_x + x^2 \cdot dp_x + dx^2 \cdot dp_x + 2x \cdot dx \cdot dp_x) + 2x \cdot dx \cdot \sigma_x$$

Neglecting squares and products of  $dx$  and  $dp_x$ , we get

$$x^2 \cdot p_x = x^2 \cdot p_x + 0 + 2x \cdot dx \cdot p_x + x^2 \cdot dp_x + 0 + 0 + 2x \cdot dx \cdot \sigma_x$$

or

$$0 = 2x \cdot dx \cdot p_x + x^2 \cdot dp_x + 2x \cdot dx \cdot \sigma_x$$

or

$$2x \cdot dx \cdot \sigma_x = -2x \cdot dx \cdot p_x - x^2 \cdot dp_x$$

or

$$2 \cdot \sigma_x = -2 \cdot p_x - x \cdot \frac{dp_x}{dx} \quad \text{(Dividing both sides by } x \cdot dx)$$

or

$$\sigma_x = -p_x - \frac{x}{2} \cdot \frac{dp_x}{dx} \quad \dots(A)$$

Differentiating the above equation w.r.t.  $x$ , we get

$$\frac{d}{dx} (\sigma_x) = \frac{d}{dx} (-p_x) - \frac{1}{2} \frac{d}{dx} \left( x \cdot \frac{dp_x}{dx} \right) = -\frac{dp_x}{dx} - \frac{1}{2} \left( x \cdot \frac{d^2 p_x}{dx^2} + \frac{dp_x}{dx} \right) \quad \dots(iv)$$

At any point in the elementary spherical shell, there are three principal stresses :

- (i) The radial pressure  $p_x$ , which is compressive
- (ii) Circumferential (or hoop stress)  $\sigma_x$ , which is tensile and
- (iii) Circumferential (or hoop stress)  $\sigma_x$ , which is tensile of the same magnitude as of (ii) and on a plane at right angles to the plane of  $\sigma_x$  of (ii).

Now radial strain,

$$e_x = \frac{p_x}{E} + \frac{\sigma_x}{mE} + \frac{\sigma_x}{mE}$$

$$= \frac{p_x}{E} + \frac{2\sigma_x}{mE}$$

$$\text{Here } \frac{1}{m} = \text{Poisson's ratio} = \mu$$

(compressive)

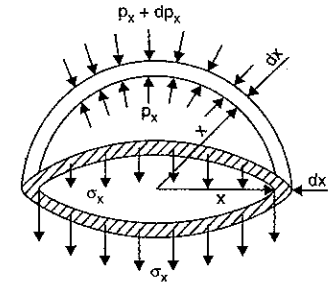

Fig. 18.7



$$= -\left(\frac{p_x}{E} + \frac{2\sigma_x}{mE}\right) \text{ (tensile)} \quad \dots(v)$$

and circumferential strain,

$$e_y = \frac{\sigma_x}{E} - \frac{\sigma_x}{mE} + \frac{p_x}{mE} \quad \text{(tensile)}$$

$$= \frac{1}{E} \left( \sigma_x - \frac{\sigma_x}{m} + \frac{p_x}{m} \right) = \frac{1}{E} \left[ \sigma_x \left( \frac{m-1}{m} \right) + \frac{p_x}{m} \right] \quad \dots(vi)$$

Substituting the values of  $e_x$  and  $e_y$  from equations (v) and (vi) in equation (vii), we get

$$-\left(\frac{p_x}{E} + \frac{2\sigma_x}{mE}\right) = \frac{1}{E} \left[ \sigma_x \left( \frac{m-1}{m} \right) + \frac{p_x}{m} \right] + x \cdot \frac{d}{dx} \left[ \frac{1}{E} \left\{ \sigma_x \left( \frac{m-1}{m} \right) + \frac{p_x}{m} \right\} \right]$$

$$\text{or } -\frac{1}{E} \left( p_x + \frac{2\sigma_x}{m} \right) = \frac{1}{E} \left[ \frac{\sigma_x(m-1)}{m} + \frac{p_x}{m} \right] + \frac{x}{E} \left[ \left( \frac{m-1}{m} \right) \frac{d\sigma_x}{dx} + \frac{1}{m} \frac{dp_x}{dx} \right]$$

$$\text{or } -\left( p_x + \frac{2\sigma_x}{m} \right) = \left( \frac{\sigma_x(m-1)}{m} + \frac{p_x}{m} \right) + \frac{x(m-1)}{m} \frac{d\sigma_x}{dx} + \frac{x}{m} \frac{dp_x}{dx}$$

$$\text{or } -mp_x - 2\sigma_x = (m-1)\sigma_x + p_x + x(m-1) \frac{d\sigma_x}{dx} + x \frac{dp_x}{dx}$$

$$\text{or } -p_x(m+1) - \sigma_x(2+m-1) = x(m-1) \frac{d\sigma_x}{dx} + x \frac{dp_x}{dx}$$

$$\text{or } -(m+1)(p_x + \sigma_x) = x(m-1) \frac{d\sigma_x}{dx} + x \frac{dp_x}{dx}$$

$$\text{or } (m+1)(p_x + \sigma_x) + x(m-1) \frac{d\sigma_x}{dx} + x \frac{dp_x}{dx} = 0.$$

Now substituting the value of  $\sigma_x$  and  $\frac{d}{dx}(\sigma_x)$  from equations (A) and (iv) in the above equation, we get

$$(m+1) \left( p_x + -p_x - \frac{x}{2} \frac{dp_x}{dx} \right) + x(m-1) \times \left[ -\frac{dp_x}{dx} - \frac{1}{2} \left( x \frac{d^2 p_x}{dx^2} + \frac{dp_x}{dx} \right) \right] + x \frac{dp_x}{dx} = 0$$

$$\text{or } (m+1) \left( -\frac{x}{2} \frac{dp_x}{dx} \right) + x(m-1) \left( -\frac{3}{2} \frac{dp_x}{dx} - \frac{1}{2} x \frac{d^2 p_x}{dx^2} \right) + x \frac{dp_x}{dx} = 0$$

$$\text{or } \frac{dp_x}{dx} \left[ -\frac{x}{2}(m+1) - \frac{3x}{2}(m-1) + x \right] - \frac{x^2(m-1)}{2} \frac{d^2 p_x}{dx^2} = 0$$

$$\text{or } x \cdot \frac{dp_x}{dx} \left[ \frac{-m-1-3m+3+2}{2} \right] - \frac{x^2}{m} (m-1) \frac{d^2 p_x}{dx^2} = 0$$

$$\text{or } \frac{dp_x}{dx} \left( \frac{-4m+4}{2} \right) - \frac{x}{2} (m-1) \frac{d^2 p_x}{dx^2} = 0 \quad \text{(Cancelling } x)$$

$$\text{or } -\frac{4}{2} \frac{dp_x}{dx} (m-1) - \frac{x}{2} (m-1) \frac{d^2 p_x}{dx^2} = 0$$

$$\text{or } \frac{4dp_x}{dx} + x \frac{d^2 p_x}{dx^2} = 0 \quad \left[ \text{Cancelling } -\frac{(m-1)}{2} \right]$$

Substituting  $\frac{dp_x}{dx} = Z$  in the above equation, we get

$$4Z + x \cdot \frac{d}{dx} \left( \frac{dp_x}{dx} \right) = 0$$

$$\text{or } 4Z + x \cdot \frac{dZ}{dx} = 0$$

$$\text{or } 4Z = -x \cdot \frac{dZ}{dx}$$

$$\text{or } \frac{dZ}{Z} = -4 \frac{dx}{x}$$

Integrating the above equation, we get

$$\log_e Z = -4 \log_e x + \log_e C_1$$

where  $C_1$  is the constant of integration.

The above equation can also be written as

$$\log_e Z = \log_e x^{-4} + \log_e C_1 = \log_e C_1 \times x^{-4}$$

$$= \log_e \left( \frac{C_1}{x^4} \right) \quad \text{or} \quad Z = \frac{C_1}{x^4}$$

$$\text{But } Z = \frac{dp_x}{dx}$$

$$\therefore \frac{dp_x}{dx} = \frac{C_1}{x^4} \quad \text{or} \quad dp_x = \frac{C_1}{x^4} dx$$

Integrating the above equation, we get

$$p_x = -\frac{C_1}{3x^3} + C_2 \quad \dots(vii)$$

where  $C_2$  is another constant of integration.

Substituting this value of  $p_x$  in equation (A), we get

$$\sigma_x = -\left( -\frac{C_1}{3x^3} + C_2 \right) - \frac{x}{2} \frac{dp_x}{dx}$$

$$= \frac{C_1}{3x^3} - C_2 - \frac{x}{2} \cdot \frac{C_1}{x^4} \quad \left( \because \frac{dp_x}{dx} = \frac{C_1}{x^4} \right)$$

$$= \frac{C_1}{3x^3} - C_2 - \frac{C_1}{2x^3} = -\frac{C_1}{6x^3} - C_2 \quad \dots(viii)$$

If we substitute  $C_1 = -6b$  and  $C_2 = -a$  in equations (vii) and (viii), we get

$$p_x = -\frac{(-6b)}{3x^3} + (-a) = \frac{2b}{x^3} - a \quad \dots(ix)$$

and

$$\sigma_x = -\frac{(-6b)}{6x^3} - (-a) = \frac{b}{x^3} + a \quad \dots(x)$$

The constants  $a$  and  $b$  are obtained from initial given conditions.

For example, (i) at  $x = r_1$ ,  $p_x = 0$  and at  $x = r_2$ ,  $p_x = p$ .

Substituting these values in equation (ix), we get

$$0 = \frac{2b}{r_1^3} - a \quad \dots(xi) \quad \text{and} \quad p = \frac{2b}{r_2^3} - a \quad \dots(xii)$$

Solving equations (xi) and (xii), we get

$$a = \frac{pr_2^3}{r_1^3 - r_2^3} \quad \text{and} \quad b = \frac{pr_1^3 r_2^3}{2(r_1^3 - r_2^3)}$$

**Problem 18.6.** A thick spherical shell of 200 mm internal diameter is subjected to an internal fluid pressure of 7 N/mm<sup>2</sup>. If the permissible tensile stress in the shell material is 8 N/mm<sup>2</sup>, find the thickness of the shell.

**Sol. Given :**

Internal dia. = 200 mm

∴ Internal radius,  $r_1 = 100$  mm

Internal fluid pressure,  $p = 7$  N/mm<sup>2</sup>

Permissible tensile stress,  $\sigma_x = 8$  N/mm<sup>2</sup>.

The radial pressure and hoop stress at any radius of spherical shell are given by

$$p_x = \frac{2b}{x^3} - a \quad \dots(i) \quad \text{and} \quad \sigma_x = \frac{b}{x^3} + a \quad \dots(ii)$$

The hoop stress,  $\sigma_x$  will be maximum at the internal radius. Hence permissible tensile stress of 8 N/mm<sup>2</sup> is the hoop stress at the internal radius.

At  $x = 100$  mm,  $p_x = 7$  N/mm<sup>2</sup>.

Substituting these values in equation (i), we get

$$7 = \frac{2b}{100^3} - a = \frac{2b}{1000000} - a \quad \dots(iii)$$

At  $x = 100$  mm,  $\sigma_x = 8$  N/mm<sup>2</sup>.

Substituting these values in equation (ii), we get

$$8 = \frac{b}{100^3} + a = \frac{b}{1000000} + a \quad \dots(iv)$$

Adding equations (iii) and (iv), we get

$$15 = \frac{3b}{1000000}$$

$$b = \frac{1000000 \times 15}{3} = 5000000.$$

Substituting the value of  $b$  in equation (iv), we get

$$8 = \frac{5000000}{1000000} + a = 5 + a$$

$$\therefore a = 8 - 5 = 3$$

Substituting the values of  $a$  and  $b$  in equation (i), we get

$$p_x = \frac{2 \times 5000000}{x^3} - 3 \quad \dots(v)$$

Let  $r_2 =$  External radius of the shell.

At outside, the pressure

$$p_x = 0 \text{ or at } x = r_2, p_x = 0.$$

Substituting these values in equation (v), we get

$$0 = \frac{2 \times 5000000}{r_1^3} - 3 \quad \text{or} \quad r_1^3 = \frac{10000000}{3}$$

$$\therefore r_1 = \left(\frac{10^7}{3}\right)^{1/3} = (3.333)^{1/3} \times 10^2 = 149.3 \text{ mm}$$

∴ Thickness of the shell,

$$t = r_2 - r_1 = 149.3 - 100 = 49.3 \text{ mm. Ans.}$$

**Problem 18.7.** For the problem 18.6, find the minimum value of the hoop stress.

**Sol. Given :**

The data from Problem 18.6 is :

$$r_1 = 100 \text{ mm, } r_2 = 149.3 \text{ mm}$$

$$p = 7 \text{ N/mm}^2, \sigma_x \text{ at internal radius} = 8 \text{ N/mm}^2$$

Values of constants are ;

$$a = 3, b = 5000000$$

The hoop stress at any radius of spherical shell is given by

$$\sigma_x = \frac{b}{x^3} + a = \frac{5000000}{x^3} + 3$$

The hoop stress will be minimum at the external radius i.e., at  $x = r_2 = 149.3$  mm.

Substituting this value of  $x$  in the above equation, we get

$$\sigma_x = \frac{5000000}{(149.3)^3} + 3 = \left(\frac{5000000}{10000000}\right) + 3 = 1.5 + 3 = 4.5 \text{ N/mm}^2. \text{ Ans.}$$

### HIGHLIGHTS

1. The hoop stress is maximum at the inner circumference and minimum at the outer circumference of a thick cylinder.
2. The radial pressure ( $p_x$ ) and hoop stress ( $\sigma_x$ ) at any radius  $x$  in case of a thick cylinder are given by

$$p_x = \frac{b}{x^2} - a \quad \text{and} \quad \sigma_x = \frac{b}{x^2} + a.$$

The above equations are known as Lamé's equations. In these equations  $a$  and  $b$  are constants whose values are obtained from boundary conditions.

3. The hoop stresses in a compound thick cylinder is the algebraic sum of the hoop stresses caused due to shrinking and those due to internal fluid pressure.
4. The hoop stress in case of thin cylinders are reduced by wire winding on the cylinders.
5. The hoop stress in case of thick cylinders are reduced by shrinking one cylinder over another cylinder.
6. The original difference of radii at the junction of a compound cylinder for shrinkage is given by,

$$dr = \frac{2r^*}{E} (a_1 - a_2)$$

where  $r^* =$  Radius of junction after shrinking

$E =$  Young's modulus

$a_1$  and  $a_2 =$  Constants whose values are obtained from boundary conditions.

7. For a thick-spherical shell, the radial pressure and hoop stresses are given by

$$p_x = \frac{2b}{x^3} - a \quad \text{and} \quad \sigma_x = \frac{b}{x^3} + a.$$

## EXERCISE 18

## (A) Theoretical Questions

1. Differentiate between a thin cylinder and a thick cylinder. Find an expression for the radial pressure and hoop stress at any point in case of a thick cylinder.
2. What do you mean by Lamé's equations? How will you derive these equations?
3. "The hoop stress is minimum at the outer surface and is maximum at the inner surface of a thick cylinder", prove this statement. Sketch the radial pressure distribution and hoop stress distribution across the section of a thick cylinder.
4. What do you mean by a thick compound cylinder? How will you determine the hoop stresses in a thick compound cylinder?
5. What are the different methods of reducing hoop stresses? Explain the terms: Wire winding of thin cylinders and shrinking one cylinder over another cylinder.
6. Prove that the original difference in radii at the junction of a compound cylinder for shrinkage is given by

$$dr = \frac{2r^*}{E} (a_1 - a_2)$$

where  $r^*$  = Common radius after shrinking

$E$  = Young's modulus

$a_1$  and  $a_2$  = Constants whose values are obtained from the boundary conditions.

7. Derive an expression for the radial pressure and hoop stress for a thick spherical shell.

## (B) Numerical Problems

1. Determine the maximum hoop stress across the section of a pipe of external diameter 600 mm and internal diameter 440 mm, when the pipe is subjected to an internal fluid pressure of 0 N/mm<sup>2</sup>. [Ans. 99.9 N/mm<sup>2</sup>]
2. Find the thickness of metal necessary for a cylindrical shell of internal diameter 150 mm to withstand an internal pressure of 50 N/mm<sup>2</sup>. The maximum hoop stress in the section is not to exceed 150 N/mm<sup>2</sup>. [Ans. 31 mm] (Annamalai University, 1990)

[Hint.  $p_x = \frac{b}{x^2} - a$ . And  $\sigma_x = \frac{b}{x^2} + a$ .

Let  $r_2$  = External radius in mm,  $r_1$  = Internal radius.

And  $x$  is any radius.

At  $x = 75$  mm,  $p_x = 50$  N/mm<sup>2</sup> and  $\sigma_x = 150$  N/mm<sup>2</sup>

$$\therefore 50 = \frac{b}{5625} - a \quad \dots(i) \quad 150 = \frac{b}{5625} + a \quad \dots(ii)$$

Solve equations (i) and (ii). The values of  $a$  and  $b$  are  $a = 50$  and  $b = 562500$ . Now at  $x = r_2$ ,  $p_x = 0$

$$\therefore 0 = \frac{b}{r_2^2} - a. \text{ Find } r_2. \text{ Then } r_2 = 106 \text{ mm. Now } t = 106 - 75 = 31 \text{ mm.}]$$

3. A compound cylinder is made by shrinking a cylinder of external diameter 200 mm and internal diameter 160 mm over another cylinder of external diameter 160 mm and internal diameter 120 mm. The radial pressure at the junction after shrinking is 8 N/mm<sup>2</sup>. Find the final stresses set up across the section, when the compound cylinder is subjected to an internal fluid pressure of 60 N/mm<sup>2</sup>.

[Ans. Inner  $F_{80} = 90.9$  and  $F_{80} = 57.9$  N/mm<sup>2</sup>; Outer  $F_{80} = 122.9$  and  $F_{100} = 25.9$  N/mm<sup>2</sup>]

4. A steel cylinder of 200 mm external diameter is to be shrunk to another steel cylinder of 100 mm internal diameter. After shrinking the diameter at the junction is 150 mm and radial pressure at the junction is 12.5 N/mm. Find the original difference in radii at the junction. Take  $E = 2 \times 10^5$  N/mm<sup>2</sup>. [Ans. 0.02025 mm]
5. A steel tube 240 mm external diameter is to be shrunk on another steel tube of 80 mm internal diameter. After shrinking, the diameter at the junction is 160 mm. Before shrinking on, the difference of diameters at the junction was 0.08 mm. Calculate the radial pressure at the junction and hoop stresses developed in the two tubes after shrinking on. Take  $E = 2 \times 10^5$  N/mm<sup>2</sup>. [Ans.  $p^* = 23.44$  N/mm<sup>2</sup>,  $\sigma_{40} = 62.5$  N/mm<sup>2</sup>,  $\sigma_{80} = 39.1$  N/mm<sup>2</sup>,  $\sigma_{120} = 37.5$  N/mm<sup>2</sup>]
6. A thick spherical shell of 400 mm internal diameter is subjected to an internal fluid pressure of 1.5 N/mm<sup>2</sup>. If the permissible tensile stress in the shell material is 3 N/mm<sup>2</sup>, find the necessary thickness of the shell. [Ans. 52 mm]

# 19

## Columns and Struts

### 19.1. INTRODUCTION

Column or strut is defined as a member of a structure, which is subjected to axial compressive load. If the member of the structure is vertical and both of its ends are fixed rigidly while subjected to axial compressive load, the member is known as *column*, for example a vertical pillar between the roof and floor. If the member of the structure is not vertical and one or both of its ends are hinged or pin joined, the bar is known as *strut*. Examples of struts are : connecting rods, piston rods etc.

### 19.2. FAILURE OF A COLUMN

The failure of a column takes place due to the any one of the following stresses set up in the columns :

- (i) Direct compressive stresses,
- (ii) Buckling stresses, and
- (iii) Combined of direct compressive and buckling stresses.

**19.2.1. Failure of a Short Column.** A short column of uniform cross-sectional area  $A$ , subjected to an axial compressive load  $P$ , is shown in Fig. 19.1. The compressive stress induced given by

$$p = \frac{P}{A}$$

If the compressive load on the short column is gradually increased, a stage will reach when the column will be on the point of failure by crushing. The stress induced in the column corresponding to this load is known as crushing stress and the load is called crushing load.

Let  $P_c$  = Crushing load,  
 $\sigma_c$  = Crushing stress, and  
 $A$  = Area of cross-section.

Then  $\sigma_c = \frac{P_c}{A}$

All short columns fail due to crushing.

**19.2.2. Failure of a Long Column.** A long column of uniform cross-sectional area  $A$  and of length  $l$ , subjected to an axial compressive load  $P$ , is shown in Fig. 19.2. A column is known as long column if the length of the column in comparison to its lateral dimensions, is very large. Such columns do not fail by crushing alone, but also by bending (also known buckling) as shown

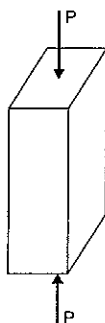

Fig. 19.1

in Fig. 19.2. The load at which the column just buckles, is known as *buckling load* or *critical just or crippling load*. The buckling load is less than the crushing load for a long column. Actually the value of buckling load for long columns is low whereas for short columns the value of buckling load is relatively high.

Refer to Fig. 19.2.

Let  $l$  = Length of a long column  
 $P$  = Load (compressive) at which the column has just buckled  
 $A$  = Cross-sectional area of the column  
 $e$  = Maximum bending of the column at the centre

$$\sigma_0 = \text{Stress due to direct load} = \frac{P}{A}$$

$$\sigma_b = \text{Stress due to bending at the centre of the column} = \frac{P \times e}{Z}$$

where  $Z$  = Section modulus about the axis of bending.

The extreme stresses on the mid-section are given by

$$\text{Maximum stress} = \sigma_0 + \sigma_b$$

and  $\text{Minimum stress} = \sigma_0 - \sigma_b$ .

The column will fail when maximum stress (i.e.,  $\sigma_0 + \sigma_b$ ) is more than the crushing stress  $\sigma_c$ . But in case of long columns, the direct compressive stresses are negligible as compared to buckling stresses. Hence very long columns are subjected to buckling stresses only.

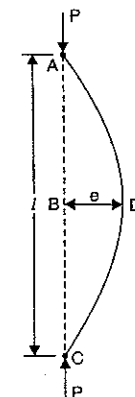

Fig. 19.2

### 19.3. ASSUMPTIONS MADE IN THE EULER'S COLUMN THEORY

The following assumptions are made in the Euler's column theory :

1. The column is initially perfectly straight and the load is applied axially.
2. The cross-section of the column is uniform throughout its length.
3. The column material is perfectly elastic, homogeneous and isotropic and obeys Hooke's law.
4. The length of the column is very large as compared to its lateral dimensions.
5. The direct stress is very small as compared to the bending stress.
6. The column will fail by buckling alone.
7. The self-weight of column is negligible.

### 19.4. END CONDITIONS FOR LONG COLUMNS

In case of long columns, the stress due to direct load is very small in comparison with the stress due to buckling. Hence the failure of long columns take place entirely due to buckling (or bending). The following four types of end conditions of the columns are important :

1. Both the ends of the column are hinged (or pinned).
2. One end is fixed and the other end is free.
3. Both the ends of the column are fixed.
4. One end is fixed and the other is pinned.

For a hinged end, the deflection is zero. For a fixed end the deflection and slope are zero. For a free end the deflection is not zero.

**19.4.1. Sign Conventions.** The following sign conventions for the bending of the columns will be used :

1. A moment which will bend the column with its *convexity* towards its initial central line as shown in Fig. 19.3 (a) is taken as positive. In Fig. 19.3 (a), *AB* represents the initial centre line of a column. Whether the column bends taking the shape *AB'* or *AB''*, the moment producing this type of curvature is positive.

2. A moment which will tend to bend the column with its *concavity* towards its initial centre line as shown in Fig. 19.3 (b) is taken as negative.

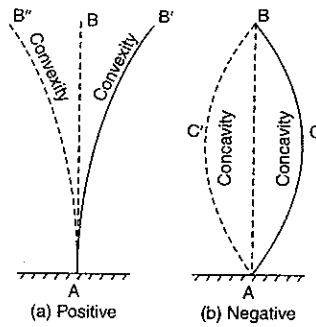

Fig. 19.3

**19.5. EXPRESSION FOR CRIPPLING LOAD WHEN BOTH THE ENDS OF THE COLUMN ARE HINGED**

The load at which the column just buckles (or bends) is called crippling load. Consider a column *AB* of length *l* and uniform cross-sectional area, hinged at both of its ends *A* and *B*. Let *P* be the crippling load at which the column has just buckled. Due to the crippling load, the column will deflect into a curved form *ACB* as shown in Fig. 19.4.

Consider any section at a distance *x* from the end *A*.

Let *y* = Deflection (lateral displacement) at the section.

The moment due to the crippling load at the section =  $-P \cdot y$

(-ve sign is taken due to sign convention

given in Art. 19.4.1)

But moment  $= EI \frac{d^2y}{dx^2}$ .

Equating the two moments, we have

$$EI \frac{d^2y}{dx^2} = -P \cdot y \quad \text{or} \quad EI \frac{d^2y}{dx^2} + P \cdot y = 0$$

or  $\frac{d^2y}{dx^2} + \frac{P}{EI} \cdot y = 0$

The solution\* of the above differential equation is

$$y = C_1 \cdot \cos \left( x \sqrt{\frac{P}{EI}} \right) + C_2 \cdot \sin \left( x \sqrt{\frac{P}{EI}} \right) \quad \dots(i)$$

where *C*<sub>1</sub> and *C*<sub>2</sub> are the constants of integration. The values of *C*<sub>1</sub> and *C*<sub>2</sub> are obtained as given below :

\*The equation  $\frac{d^2y}{dx^2} + \frac{P}{EI} \cdot y = 0$  can be written as  $\frac{d^2y}{dx^2} + \alpha^2 y = 0$  where  $\alpha^2 = \frac{P}{EI}$  or  $\alpha = \sqrt{\frac{P}{EI}}$

The solution of the equation is  $y = C_1 \cos (\alpha x) + C_2 \sin (\alpha x)$

$$= C_1 \cos \left( \sqrt{\frac{P}{EI}} \times x \right) + C_2 \sin \left( \sqrt{\frac{P}{EI}} \times x \right) \quad \text{as } \alpha = \sqrt{\frac{P}{EI}}$$

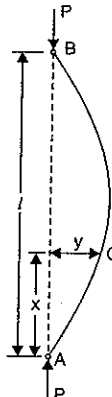

Fig. 19.4

(i) At *A*,  $x = 0$  and  $y = 0$  (See Fig. 19.4)

Substituting these values in equation (i), we get

$$\begin{aligned} 0 &= C_1 \cdot \cos 0^\circ + C_2 \sin 0 \\ &= C_1 \times 1 + C_2 \times 0 \quad (\because \cos 0 = 1 \text{ and } \sin 0 = 0) \\ &= C_1 \end{aligned}$$

$\therefore C_1 = 0$  ... (ii)

(ii) At *B*,  $x = l$  and  $y = 0$  (See Fig. 19.4).

Substituting these values in equation (i), we get

$$\begin{aligned} 0 &= C_1 \cdot \cos \left( l \times \sqrt{\frac{P}{EI}} \right) + C_2 \cdot \sin \left( l \times \sqrt{\frac{P}{EI}} \right) \\ &= 0 + C_2 \cdot \sin \left( l \times \sqrt{\frac{P}{EI}} \right) \quad [ \because C_1 = 0 \text{ from equation (ii)} ] \\ &= C_2 \sin \left( l \sqrt{\frac{P}{EI}} \right) \quad \dots(iii) \end{aligned}$$

From equation (iii), it is clear that either  $C_2 = 0$

or  $\sin \left( l \sqrt{\frac{P}{EI}} \right) = 0$ .

As  $C_1 = 0$ , then if  $C_2$  is also equal to zero, then from equation (i) we will get  $y = 0$ . This means that the bending of the column will be zero or the column will not bend at all. Which is not true.

$\therefore \sin \left( l \sqrt{\frac{P}{EI}} \right) = 0$   
 $= \sin 0 \text{ or } \sin \pi \text{ or } \sin 2\pi \text{ or } \sin 3\pi \text{ or } \dots$

or  $l \sqrt{\frac{P}{EI}} = 0 \text{ or } \pi \text{ or } 2\pi \text{ or } 3\pi \text{ or } \dots$

Taking the least practical value,

$$l \sqrt{\frac{P}{EI}} = \pi$$

or  $P = \frac{\pi^2 EI}{l^2}$  ... (19.1)

**19.6. EXPRESSION FOR CRIPPLING LOAD WHEN ONE END OF THE COLUMN IS FIXED AND THE OTHER END IS FREE**

Consider a column *AB*, of length *l* and uniform cross-sectional area, fixed at the end *A* and free at the end *B*. The free end will sway sideways when load is applied at free end and curvature in the length *l* will be similar to that of upper half of the column whose both ends are hinged. Let *P* is the crippling load at which the column has just buckled. Due to the crippling load *P*, the column will deflect as shown in Fig. 19.5 in which *AB* is the original position of the column and *AB'*, is the deflected position due to crippling load *P*.

Consider any section at a distance *x* from the fixed end *A*.

Let  $y$  = Deflection (or lateral displacement) at the section

$a$  = Deflection at the free end  $B$ .

Then moment at the section due to the crippling load =  $P(a - y)$   
(+ve sign is taken due to sign convention given in Art. 19.4.1)

But moment is also =  $EI \frac{d^2 y}{dx^2}$

∴ Equating the two moments, we get

$$EI \frac{d^2 y}{dx^2} = P(a - y) = P \cdot a - P \cdot y$$

$$EI \frac{d^2 y}{dx^2} + P \cdot y = P \cdot a$$

$$\frac{d^2 y}{dx^2} + \frac{P}{EI} \cdot y = \frac{P}{EI} \cdot a \quad \dots(A)$$

The solution\* of the differential equation is

$$y = C_1 \cdot \cos \left( x \sqrt{\frac{P}{EI}} \right) + C_2 \cdot \sin \left( x \sqrt{\frac{P}{EI}} \right) + a \quad \dots(i)$$

where  $C_1$  and  $C_2$  are constant of integration. The values of  $C_1$  and  $C_2$  are obtained from boundary conditions. The boundary conditions are :

(i) For a fixed end, the deflection as well as slope is zero.

Hence at end  $A$  (which is fixed), the deflection  $y = 0$  and also slope  $\frac{dy}{dx} = 0$ .

Hence at  $A$ ,  $x = 0$  and  $y = 0$

Substituting these values in equation (i), we get

$$\begin{aligned} 0 &= C_1 \cdot \cos 0 + C_2 \sin 0 + a \\ &= C_1 \times 1 + C_2 \times 0 + a \quad (\because \cos 0 = 1, \sin 0 = 0) \\ &= C_1 + a \end{aligned}$$

$$\therefore C_1 = -a \quad \dots(ii)$$

At  $A$ ,  $x = 0$  and  $\frac{dy}{dx} = 0$ .

Differentiating the equation (i) w.r.t.  $x$ , we get

$$\frac{dy}{dx} = C_1 \cdot (-1) \sin \left( x \sqrt{\frac{P}{EI}} \right) \cdot \sqrt{\frac{P}{EI}} + C_2 \cos \left( x \sqrt{\frac{P}{EI}} \right) \cdot \sqrt{\frac{P}{EI}} + 0$$

\*The equation (A) can be written as

$$\frac{d^2 y}{dx^2} + \alpha^2 y = \alpha^2 \times a \text{ where } \alpha^2 = \frac{P}{EI} \text{ or } \alpha = \sqrt{\frac{P}{EI}}$$

The complete solution of this equation is  $y = C_1 \cos(\alpha \cdot x) + C_2 \sin(\alpha \cdot x) + \frac{\alpha^2 \times a}{\alpha^2}$

$$= C_1 \cos \left( \sqrt{\frac{P}{EI}} \times x \right) + C_2 \sin \left( \sqrt{\frac{P}{EI}} \times x \right) + a$$

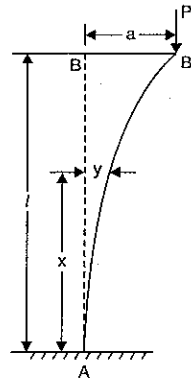

Fig. 19.5

$$= -C_1 \cdot \sqrt{\frac{P}{EI}} \sin \left( x \sqrt{\frac{P}{EI}} \right) + C_2 \cdot \sqrt{\frac{P}{EI}} \cos \left( x \sqrt{\frac{P}{EI}} \right)$$

But at  $A$ ,  $x = 0$  and  $\frac{dy}{dx} = 0$ .

∴ The above equation becomes as

$$0 = -C_1 \cdot \sqrt{\frac{P}{EI}} \sin 0 + C_2 \sqrt{\frac{P}{EI}} \cos 0$$

$$= -C_1 \sqrt{\frac{P}{EI}} \times 0 + C_2 \cdot \sqrt{\frac{P}{EI}} \times 1 = C_2 \sqrt{\frac{P}{EI}}$$

From the above equation it is clear that either  $C_2 = 0$ .

$$\text{or } \sqrt{\frac{P}{EI}} = 0.$$

But for the crippling load  $P$ , the value of  $\sqrt{\frac{P}{EI}}$  cannot be equal to zero.

$$\therefore C_2 = 0.$$

Substituting the values of  $C_1 = -a$  and  $C_2 = 0$  in equation (i), we get

$$y = -a \cdot \cos \left( x \sqrt{\frac{P}{EI}} \right) + a \quad \dots(iii)$$

But at the free end of the column,  $x = l$  and  $y = a$ .

Substituting these values in equation (iii), we get

$$a = -a \cdot \cos \left( l \cdot \sqrt{\frac{P}{EI}} \right) + a$$

$$\text{or } 0 = -a \cdot \cos \left( l \cdot \sqrt{\frac{P}{EI}} \right) \text{ or } a \cos \left( l \cdot \sqrt{\frac{P}{EI}} \right) = 0$$

But ' $a$ ' cannot be equal to zero

$$\therefore \cos \left( l \cdot \sqrt{\frac{P}{EI}} \right) = 0 = \cos \frac{\pi}{2} \text{ or } \cos \frac{3\pi}{2} \text{ or } \cos \frac{5\pi}{2} \text{ or } \dots$$

$$\therefore l \cdot \sqrt{\frac{P}{EI}} = \frac{\pi}{2} \text{ or } \frac{3\pi}{2} \text{ or } \frac{5\pi}{2} \dots$$

Taking the least practical value,

$$l \cdot \sqrt{\frac{P}{EI}} = \frac{\pi}{2} \text{ or } \sqrt{\frac{P}{EI}} = \frac{\pi}{2l}$$

$$\text{or } P = \frac{\pi^2 EI}{4l^2} \quad \dots(19.2)$$

### 19.7. EXPRESSION FOR CRIPPLING LOAD WHEN BOTH THE ENDS OF THE COLUMN ARE FIXED

Consider a column  $AB$  of length  $l$  and uniform cross-sectional area fixed at both of its ends  $A$  and  $B$  as shown in Fig. 19.6. Let  $P$  is the crippling load at which the column has buckled.

Due to the crippling load  $P$ , the column will deflect as shown in Fig. 19.6. Due to fixed ends, there will be fixed end moments (say  $M_0$ ) at the ends  $A$  and  $B$ . The fixed end moments will be acting in such direction so that slope at the fixed ends becomes zero.

Consider a section at a distance  $x$  from the end  $A$ . Let the deflection of the column at the section is  $y$ . As both the ends of the column are fixed and the column carries a crippling load, there will be some fixed end moments at  $A$  and  $B$ .

Let  $M_0$  = Fixed end moments at  $A$  and  $B$ .

Then moment at the section =  $M_0 - P \cdot y$

But moment at the section is also =  $EI \frac{d^2 y}{dx^2}$

∴ Equating the two moments, we get

$$EI \frac{d^2 y}{dx^2} = M_0 - P \cdot y$$

$$\text{or } EI \frac{d^2 y}{dx^2} + P \cdot y = M_0$$

$$\begin{aligned} \text{or } \frac{d^2 y}{dx^2} + \frac{P}{EI} \cdot y &= \frac{M_0}{EI} \quad \dots(A) \\ &= \frac{M_0}{EI} \times \frac{P}{P} = \frac{P}{EI} \cdot \frac{M_0}{P} \end{aligned}$$

The solution\* of the above differential equation is

$$y = C_1 \cdot \cos \left( x \cdot \sqrt{\frac{P}{EI}} \right) + C_2 \cdot \sin \left( x \cdot \sqrt{\frac{P}{EI}} \right) + \frac{M_0}{P} \quad \dots(i)$$

where  $C_1$  and  $C_2$  are constant of integration and their values are obtained from boundary conditions. Boundary conditions are :

(i) At  $A$ ,  $x = 0$ ,  $y = 0$  and also  $\frac{dy}{dx} = 0$  as  $A$  is a fixed end.

(ii) At  $B$ ,  $x = l$ ,  $y = 0$  and also  $\frac{dy}{dx} = 0$  as  $B$  is also a fixed end.

\*The equation (A) can be written as

$$\frac{d^2 y}{dx^2} + \alpha^2 \times y = \frac{M_0}{EI} \quad \text{where } \alpha^2 = \frac{P}{EI} \quad \text{or } \alpha = \sqrt{\frac{P}{EI}}$$

The complete solution of this equation is

$$\begin{aligned} y &= C_1 \cos(\alpha \cdot x) + C_2 \sin(\alpha \cdot x) + \frac{M_0}{EI \times \alpha^2} \\ &= C_1 \cos \left( \sqrt{\frac{P}{EI}} \times x \right) + C_2 \sin \left( \sqrt{\frac{P}{EI}} \times x \right) + \frac{M_0}{EI \times \frac{P}{EI}} \\ &= C_1 \cos \left( x \times \sqrt{\frac{P}{EI}} \right) + C_2 \sin \left( x \times \frac{P}{\sqrt{EI}} \right) + \frac{M_0}{P} \end{aligned}$$

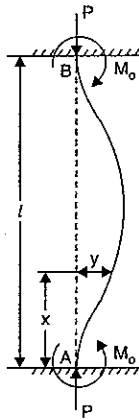

Fig. 19.6

Substituting the value  $x = 0$  and  $y = 0$  in equation (i), we get

$$0 = C_1 \times 1 + C_2 \times 0 + \frac{M_0}{P} \quad (\because \cos 0 = 1)$$

$$= C_1 + \frac{M_0}{P}$$

$$\therefore C_1 = -\frac{M_0}{P} \quad \dots(ii)$$

Differentiating the equation (i), with respect to  $x$ , we get

$$\frac{dy}{dx} = C_1 \cdot (-1) \sin \left( x \cdot \sqrt{\frac{P}{EI}} \right) \cdot \sqrt{\frac{P}{EI}} + C_2 \cos \left( x \cdot \sqrt{\frac{P}{EI}} \right) \cdot \sqrt{\frac{P}{EI}} + 0$$

$$= -C_1 \sin \left( x \cdot \sqrt{\frac{P}{EI}} \right) \cdot \sqrt{\frac{P}{EI}} + C_2 \cos \left( x \cdot \sqrt{\frac{P}{EI}} \right) \cdot \sqrt{\frac{P}{EI}}$$

Substituting the value  $x = 0$  and  $\frac{dy}{dx} = 0$ , the above equation becomes

$$0 = -C_1 \times 0 + C_2 \times 1 \times \sqrt{\frac{P}{EI}} \quad (\because \sin 0 = 0 \text{ and } \cos 0 = 1)$$

$$= C_2 \sqrt{\frac{P}{EI}}$$

From the above equation, it is clear that either  $C_2 = 0$  or  $\sqrt{\frac{P}{EI}} = 0$ . But for a given

crippling load  $P$ , the value of  $\sqrt{\frac{P}{EI}}$  cannot be equal to zero.

$$\therefore C_2 = 0.$$

Now substituting the values of  $C_1 = -\frac{M_0}{P}$  and  $C_2 = 0$  in equation (i), we get

$$y = -\frac{M_0}{P} \cos \left( x \sqrt{\frac{P}{EI}} \right) + 0 + \frac{M_0}{P}$$

$$= -\frac{M_0}{P} \cos \left( x \sqrt{\frac{P}{EI}} \right) + \frac{M_0}{P} \quad \dots(iii)$$

At the end  $B$  of the column,  $x = l$  and  $y = 0$ .

Substituting these values in equation (iii), we get

$$0 = -\frac{M_0}{P} \cos \left( l \cdot \sqrt{\frac{P}{EI}} \right) + \frac{M_0}{P}$$

$$\text{or } \frac{M_0}{P} \cos \left( l \cdot \sqrt{\frac{P}{EI}} \right) = \frac{M_0}{P}$$

$$\text{or } \cos \left( l \cdot \sqrt{\frac{P}{EI}} \right) = \frac{M_0}{P} \times \frac{P}{M_0} = 1 = \cos 0, \cos 2\pi, \cos 4\pi, \cos 6\pi, \dots$$

$$l \cdot \sqrt{\frac{P}{EI}} = 0, 2\pi, 4\pi, 6\pi, \dots$$

Taking the least practical value,

$$l \cdot \sqrt{\frac{P}{EI}} = 2\pi \quad \text{or} \quad P = \frac{\pi^2 EI}{l^2} \quad \dots(19.3)$$

### 19.8. EXPRESSION FOR CRIPPLING LOAD WHEN ONE END OF THE COLUMN IS FIXED AND THE OTHER END IS HINGED (OR PINNED)

Consider a column  $AB$  of length  $l$  and uniform cross-sectional area fixed at the end  $A$  and hinged at the end  $B$  as shown in Fig. 19.7. Let  $P$  be the crippling load at which the column has buckled. Due to the crippling load  $P$ , the column will deflect as shown in Fig. 19.7.

There will be fixed end moment ( $M_0$ ) at the fixed end  $A$ . This will try to bring back the slope of deflected column zero at  $A$ . Hence it will be acting anticlockwise at  $A$ . The fixed end moment  $M_0$  at  $A$  is to be balanced. This will be balanced by a horizontal reaction ( $H$ ) at the top end  $B$  as shown in Fig. 19.7.

Consider a section at a distance  $x$  from the end  $A$ .

Let  $y$  = Deflection of the column at the section,

$M_0$  = Fixed end moment at  $A$ , and

$H$  = Horizontal reaction at  $B$ .

The moment at the section = Moment due to crippling load at  $B$   
+ Moment due to horizontal reaction at  $B$   
=  $-P \cdot y + H \cdot (l - x)$

But the moment at the section is also

$$= EI \frac{d^2 y}{dx^2}$$

Equating the two moments, we get

$$EI \frac{d^2 y}{dx^2} = -P \cdot y + H(l - x)$$

or 
$$EI \frac{d^2 y}{dx^2} + P \cdot y = H(l - x)$$

or 
$$\frac{d^2 y}{dx^2} + \frac{P}{EI} \cdot y = \frac{H}{EI} (l - x)$$

$$= \frac{H}{EI} (l - x) \times \frac{P}{P} = \frac{P}{EI} \cdot \frac{H(l - x)}{P}$$

(Dividing by  $EI$ ) ... (A)

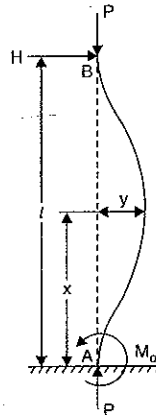

Fig. 19.7

The solution\* of the above differential equation is

$$y = C_1 \cos \left( x \sqrt{\frac{P}{EI}} \right) + C_2 \sin \left( x \sqrt{\frac{P}{EI}} \right) + \frac{H}{P} (l - x) \quad \dots(i)$$

where  $C_1$  and  $C_2$  are constants of integration and their values are obtained from boundary conditions. Boundary conditions are :

(i) At the fixed end  $A$ ,  $x = 0$ ,  $y = 0$  and also  $\frac{dy}{dx} = 0$

(ii) At the hinged end  $B$ ,  $x = l$  and  $y = 0$ .

Substituting the value  $x = 0$  and  $y = 0$  in equation (i), we get

$$0 = C_1 \times 1 + C_2 \times 0 + \frac{H}{P} (l - 0) = C_1 + \frac{H \cdot l}{P}$$

$$\therefore C_1 = -\frac{H}{P} \cdot l \quad \dots(ii)$$

Differentiating the equation (i) w.r.t.  $x$ , we get

$$\begin{aligned} \frac{dy}{dx} &= C_1 (-1) \sin \left( x \cdot \sqrt{\frac{P}{EI}} \right) \cdot \sqrt{\frac{P}{EI}} + C_2 \cos \left( x \cdot \sqrt{\frac{P}{EI}} \right) \cdot \sqrt{\frac{P}{EI}} - \frac{H}{P} \\ &= -C_1 \sin \left( x \cdot \sqrt{\frac{P}{EI}} \right) \cdot \sqrt{\frac{P}{EI}} + C_2 \cos \left( x \cdot \sqrt{\frac{P}{EI}} \right) \cdot \sqrt{\frac{P}{EI}} - \frac{H}{P} \end{aligned}$$

At  $A$ ,  $x = 0$  and  $\frac{dy}{dx} = 0$ .

$$\begin{aligned} \therefore 0 &= -C_1 \times 0 + C_2 \cdot 1 \cdot \sqrt{\frac{P}{EI}} - \frac{H}{P} \quad (\because \sin 0 = 0, \cos 0 = 1) \\ &= C_2 \sqrt{\frac{P}{EI}} - \frac{H}{P} \quad \text{or} \quad C_2 = \frac{H}{P} \sqrt{\frac{EI}{P}} \end{aligned}$$

Substituting the values of  $C_1 = -\frac{H}{P} \cdot l$  and  $C_2 = \frac{H}{P} \sqrt{\frac{EI}{P}}$  in equation (i), we get

$$y = -\frac{H}{P} \cdot l \cos \left( x \sqrt{\frac{P}{EI}} \right) + \frac{H}{P} \sqrt{\frac{EI}{P}} \sin \left( x \sqrt{\frac{P}{EI}} \right) + \frac{H}{P} (l - x)$$

\*The equation (A) can be written as

$$\frac{d^2 y}{dx^2} + \alpha^2 \cdot y = \frac{H}{EI} (l - x) \quad \text{where} \quad \alpha^2 = \frac{P}{EI} \quad \text{or} \quad \alpha = \sqrt{\frac{P}{EI}}$$

The complete solution of this equation is

$$\begin{aligned} y &= C_1 \cos (\alpha \cdot x) + C_2 \sin (\alpha \cdot x) + \frac{H(l - x)}{EI \times \alpha^2} \\ &= C_1 \cos \left( \sqrt{\frac{P}{EI}} \times x \right) + C_2 \sin \left( \sqrt{\frac{P}{EI}} \times x \right) + \frac{H}{EI} \times \frac{(l - x)}{\left( \frac{P}{EI} \right)} \\ &= C_1 \cos \left( x \times \sqrt{\frac{P}{EI}} \right) + C_2 \sin \left( x \times \sqrt{\frac{P}{EI}} \right) + \frac{H}{P} (l - x) \end{aligned}$$



At the end  $B$ ,  $x = l$  and  $y = 0$ .

Hence the above equation becomes as

$$0 = -\frac{H}{P} l \cos \left( l \sqrt{\frac{P}{EI}} \right) + \frac{H}{P} \sqrt{\frac{EI}{P}} \sin \left( l \sqrt{\frac{P}{EI}} \right) + \frac{H}{P} (l - l)$$

$$= -\frac{H}{P} l \cos \left( l \sqrt{\frac{P}{EI}} \right) + \frac{H}{P} \sqrt{\frac{EI}{P}} \sin \left( l \sqrt{\frac{P}{EI}} \right) + 0$$

or 
$$\frac{H}{P} \sqrt{\frac{EI}{P}} \sin \left( l \sqrt{\frac{P}{EI}} \right) = \frac{H}{P} l \cos \left( l \sqrt{\frac{P}{EI}} \right)$$

or 
$$\sin \left( l \sqrt{\frac{P}{EI}} \right) = \frac{H}{P} \cdot l \times \frac{P}{H} \times \sqrt{\frac{P}{EI}} \cdot \cos \left( l \sqrt{\frac{P}{EI}} \right)$$

$$= l \cdot \sqrt{\frac{P}{EI}} \cdot \cos \left( l \sqrt{\frac{P}{EI}} \right)$$

or 
$$\tan \left( l \sqrt{\frac{P}{EI}} \right) = l \cdot \sqrt{\frac{P}{EI}}$$

The solution to the above equation is,  $l \cdot \sqrt{\frac{P}{EI}} = 4.5$  radians

Squaring both sides, we get

$$l^2 \cdot \frac{P}{EI} = 4.5^2 = 20.25$$

$$\therefore P = 20.25 \frac{EI}{l^2}$$

But approximately  $20.25 = 2\pi^2$

$$\therefore P = \frac{2\pi^2 EI}{l^2} \quad \dots(19.4)$$

### 19.9. EFFECTIVE LENGTH (OR EQUIVALENT LENGTH) OF A COLUMN

The effective length of a given column with given end conditions is the length of an equivalent column of the same material and cross-section with hinged ends, and having the value of the crippling load equal to that of the given column. Effective length is also called equivalent length.

Let  $L_e$  = Effective length of a column,

$l$  = Actual length of the column, and

$P$  = Crippling load for the column.

Then the crippling load for any type of end condition is given by

$$P = \frac{\pi^2 EI}{L_e^2} \quad \dots(19.5)$$

The crippling load ( $P$ ) in terms of actual length and effective length and also the relation between effective length and actual length are given in Table 19.1.

TABLE 19.1

S.No.	End conditions of column	Crippling load in terms of		Relation between effective length and actual length
		Actual length	Effective length	
1.	Both ends hinged	$\frac{\pi^2 EI}{l^2}$	$\frac{\pi^2 EI}{L_e^2}$	$L_e = l$
2.	One end is fixed and other is free	$\frac{\pi^2 EI}{4l^2}$	$\frac{\pi^2 EI}{L_e^2}$	$L_e = 2l$
3.	Both ends fixed	$\frac{4\pi^2 EI}{l^2}$	$\frac{\pi^2 EI}{L_e^2}$	$L_e = \frac{l}{2}$
4.	One end fixed and other is hinged	$\frac{4\pi^2 EI}{l^2}$	$\frac{\pi^2 EI}{L_e^2}$	$L_e = \frac{l}{\sqrt{2}}$

There are two values of moment of inertia i.e.,  $I_{xx}$  and  $I_{yy}$ .

The value of  $I$  (moment of inertia) in the above expressions should be taken as the least value of the two moments of inertia as the column will tend to bend in the direction of least moment of inertia.

#### 19.9.1. Crippling Stress in Terms of Effective Length and Radius of Gyration.

The moment of inertia ( $I$ ) can be expressed in terms of radius of gyration ( $k$ ) as

$$I = Ak^2 \text{ where } A = \text{Area of cross-section.}$$

As  $I$  is the least value of moment of inertia, then

$$k = \text{Least radius of gyration of the column section.}$$

Now crippling load  $P$  in terms of effective length is given by

$$P = \frac{\pi^2 EI}{L_e^2} = \frac{\pi^2 E \times Ak^2}{L_e^2} \quad (\because I = Ak^2)$$

$$= \frac{\pi^2 E \times A}{\frac{L_e^2}{k^2}} = \frac{\pi^2 E \times A}{\left(\frac{L_e}{k}\right)^2} \quad \dots(19.6)$$

And the stress corresponding to crippling load is given by

$$\text{Crippling stress} = \frac{\text{Crippling load}}{\text{Area}} = \frac{P}{A}$$

$$= \frac{\pi^2 E \times A}{A \left(\frac{L_e}{k}\right)^2} \quad (\text{Substituting the value of } P)$$

$$= \frac{\pi^2 E}{\left(\frac{L_e}{k}\right)^2} \quad \dots(19.7)$$

**19.9.2. Slenderness Ratio.** The ratio of the actual length of a column to the least radius of gyration of the column, is known as slenderness ratio.

Mathematically, slenderness ratio is given by

$$\text{Slenderness ratio} = \frac{\text{Actual length}}{\text{Least radius of gyration}} = \frac{l}{k} \quad \dots(19.8)$$

### 19.10. LIMITATION OF EULER'S FORMULA

From equation (19.6), we have

$$\text{Crippling stress} = \frac{\pi^2 E}{\left(\frac{L_e}{k}\right)^2}$$

For a column with both ends hinged,  $L_e = l$ . Hence Crippling stress becomes as  $= \frac{\pi^2 E}{\left(\frac{l}{k}\right)^2}$ ,

where  $\frac{l}{k}$  is slenderness ratio.

If the slenderness ratio (i.e.,  $\frac{l}{k}$ ) is small, the crippling stress (or the stress at failure)

will be high. But for the column material, the crippling stress cannot be greater than the crushing stress. Hence when the slenderness ratio is less than a certain limit, Euler's formula gives a value of crippling stress greater than the crushing stress. In the limiting case, we can find the value of  $l/k$  for which crippling stress is equal to crushing stress.

For example, for a mild steel column with both ends hinged,

Crushing stress = 330 N/mm<sup>2</sup>

Young's modulus,  $E = 2.1 \times 10^5$  N/mm<sup>2</sup>.

Equating the crippling stress to the crushing stress corresponding to the minimum value of slenderness ratio, we get

Crippling stress = Crushing stress

$$\text{or} \quad \frac{\pi^2 E}{\left(\frac{l}{k}\right)^2} = 330 \quad \text{or} \quad \frac{\pi^2 \times 2.1 \times 10^5}{\left(\frac{l}{k}\right)^2} = 330$$

$$\therefore \left(\frac{l}{k}\right)^2 = \frac{\pi^2 \times 2.1 \times 10^5}{330} = 6282$$

$$\therefore \frac{l}{k} = \sqrt{6282} = 79.27, \text{ say } 80.$$

Hence, if the slenderness ratio is less than 80 for mild steel column with both ends hinged, then Euler's formula will not be valid.

**Problem 19.1.** A solid round bar 3 m long and 5 cm in diameter is used as a strut with both ends hinged. Determine the crippling (or collapsing) load. Take  $E = 2.0 \times 10^5$  N/mm<sup>2</sup>.

**Sol. Given :**

Length of bar,  $l = 3 \text{ m} = 3000 \text{ mm}$

Diameter of bar,  $d = 5 \text{ cm} = 50 \text{ mm}$

Young's modulus,  $E = 2.0 \times 10^5 \text{ N/mm}^2$

Moment of inertia,  $I = \frac{\pi}{64} \times 5^4 = 30.68 \text{ cm}^4 = 30.68 \times 10^4 \text{ mm}^4$

Let  $P =$  Crippling load.

As both the ends of the bar are hinged, hence the crippling load is given by equation (19.1).

$$\therefore P = \frac{\pi^2 EI}{l^2} = \frac{\pi^2 \times 2 \times 10^5 \times 30.68 \times 10^4}{3000^2} = 67288 \text{ N} = 67.288 \text{ kN. Ans.}$$

**Problem 19.2.** For the problem 19.1 determine the crippling load, when the given strut is used with the following conditions :

(i) One end of the strut is fixed and the other end is free

(ii) Both the ends of strut are fixed

(iii) One end is fixed and other is hinged.

**Sol. Given :**

The data from Problem 19.1, is  $l = 3000 \text{ mm}$ , diameter = 50 mm,  $E = 2.0 \times 10^5 \text{ N/mm}^2$  and  $I = 30.68 \times 10^4 \text{ mm}^4$ .

Let  $P =$  Crippling load.

(i) Crippling load when one end is fixed and other is free

$$\text{Using equation (19.2), } P = \frac{\pi^2 EI}{4l^2} = \frac{\pi^2 \times 2 \times 10^5 \times 30.68 \times 10^4}{4 \times 3000^2} = 16822 \text{ N. Ans.}$$

**Alternate Method**

The crippling load for any type of end condition is given by equation (19.5) as,

$$P = \frac{\pi^2 EI}{L_e^2} \quad \dots(i)$$

where  $L_e =$  Effective length.

The effective length ( $L_e$ ) when one end is fixed and other end is free from Table 19.1 on page 819 is given as

$$L_e = 2l = 2 \times 3000 = 6000 \text{ mm}$$

Substituting the value of  $L$  in equation (i), we get

$$P = \frac{\pi^2 \times 2 \times 10^5 \times 30.68 \times 10^4}{6000^2} = 16822 \text{ N. Ans.}$$

(ii) Crippling load when both the ends are fixed

$$\text{Using equation (19.3), } P = \frac{4\pi^2 EI}{l^2} = \frac{4\pi^2 \times 2 \times 10^5 \times 30.68 \times 10^4}{3000^2} = 269152 \text{ N} = 269.152 \text{ kN. Ans.}$$

**Alternate Method**

$$\text{Using equation (19.5), } P = \frac{\pi^2 EI}{L_e^2}$$

where  $L_e$  = Effective length

$$= \frac{l}{2} \quad (\text{when both the ends are fixed})$$

$$= \frac{3000}{2} \quad (\because l = 3000)$$

$$= 1500 \text{ mm}$$

$$\therefore P = \frac{\pi^2 \times 2.0 \times 10^5 \times 30.68 \times 10^4}{1500^2} = 269152 \text{ N. Ans.}$$

(iii) Crippling load when one end is fixed and the other is hinged

$$\text{Using equation (19.4), } P = \frac{2\pi^2 EI}{l^2} = \frac{2 \times \pi^2 \times 2.0 \times 10^5 \times 30.68 \times 10^4}{3000^2} = 134576 \text{ N. Ans.}$$

**Alternate Method**

$$\text{Using equation (19.5), } P = \frac{\pi^2 EI}{L_e^2}$$

where  $L_e$  = Effective length.

$$= \frac{l}{\sqrt{2}} \quad (\text{when one end is fixed and the other is hinged})$$

$$= \frac{3000}{\sqrt{2}}$$

$$\therefore P = \frac{\pi^2 \times 2.0 \times 10^5 \times 30.68 \times 10^4}{\left(\frac{3000}{\sqrt{2}}\right)^2} = 134576 \text{ N. Ans.}$$

**Problem 19.3.** A column of timber section 15 cm × 20 cm is 6 metre long both ends being fixed. If the Young's modulus for timber = 17.5 kN/mm<sup>2</sup>, determine :

(i) Crippling load and

(ii) Safe load for the column if factor of safety = 3.

**Sol.** Given :

Dimension of section = 15 cm × 20 cm

Actual length,  $l = 6 \text{ m} = 6000 \text{ mm}$

Young's modulus,  $E = 17.5 \text{ kN/mm}^2$

(i) Let  $P$  = Crippling load

Using equation (19.5), we get

$$P = \frac{\pi^2 EI}{L_e^2} \quad \dots(i)$$

where  $L_e$  = Effective length

$$= \frac{l}{2} \quad (\text{when both the ends are fixed})$$

$$= \frac{6000}{2} = 3000 \text{ mm} \quad (\because l = 6000 \text{ mm})$$

$l$  = Least value of moment of inertia

Moment of inertia of the section about X-X axis,

$$I_{XX} = \frac{15 \times 20^3}{12} = 10000 \text{ cm}^4$$

$$= 10000 \times 10^4 \text{ mm}^4$$

And moment of inertia of the section about Y-Y axis,

$$I_{YY} = \frac{20 \times 15^3}{12} = 5625 \text{ cm}^4$$

$$= 5625 \times 10^4 \text{ mm}^4.$$

Since  $I_{YY}$  is less than  $I_{XX}$ , therefore the column will tend to buckle in Y-Y direction.

And the value of  $I$  will be the least value of the two moment of inertia.

$$\therefore I = 5625 \text{ cm}^4 = 5625 \times 10^4 \text{ mm}^4$$

Substituting the values of  $I = 5625 \times 10^4 \text{ mm}^4$  and  $L = 3000 \text{ mm}$  in equation (i), we get

$$P = \frac{\pi^2 \times 17.5 \times 5625 \times 10^4}{3000} = 1079.48 \text{ kN. Ans.}$$

(ii) Safe load for the column

Factor of safety = 3.0 (given)

$$\therefore \text{Safe load} = \frac{\text{Crippling load}}{\text{Factor of safety}} = \frac{1079.48}{3} = 359.8 \text{ say } 360 \text{ kN. Ans.}$$

**Problem 19.4.** A hollow mild steel tube 6 m long 4 cm internal diameter and 6 mm thick is used as a strut with both ends hinged. Find the crippling load and safe load taking factor of safety as 3. Take  $E = 2 \times 10^5 \text{ N/mm}^2$ .

**Sol.** Given :

Length of tube,  $l = 6 \text{ m} = 600 \text{ cm}$

Internal dia.,  $d = 4 \text{ cm}$

Thickness,  $t = 5 \text{ mm} = 0.5 \text{ cm}$

$\therefore$  External dia.,  $D = d + 2t = 4 + 2 \times 0.5 = 4 + 1 = 5 \text{ cm}$

Young's modulus,  $E = 2 \times 10^5 \text{ N/mm}^2$

Factor of safety = 3.0

$$\text{Moment of inertia of section, } I = \frac{\pi}{64} (D^4 - d^4) = \frac{\pi}{64} [5^4 - 4^4] \text{ cm}^4$$

$$= \frac{\pi}{64} (625 - 256) = 18.11 \text{ cm}^4 = 18.11 \times 10^4 \text{ mm}^4$$

Since both ends of the strut are hinged,

$\therefore$  Effective length,  $L_e = l = 600 \text{ cm} = 6000 \text{ mm}$

Let  $P$  = Crippling load

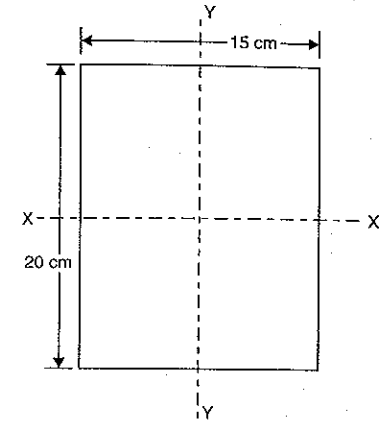

Fig. 19.8

Using equation (19.5), we get

$$P = \frac{\pi^2 EI}{L_e^2} = \frac{\pi^2 \times 2.0 \times 10^5 \times 18.11 \times 10^4}{6000^2} = 9929.9 \text{ say } 9930 \text{ N. Ans.}$$

And safe load =  $\frac{\text{Crippling load}}{\text{Factor of safety}} = \frac{9930}{3.0} = 3310 \text{ N. Ans.}$

**Problem 19.4 (a).** A simply supported beam of length 4 metre is subjected to a uniformly distributed load of 30 kN/m over the whole span and deflects 15 mm at the centre. Determine the crippling loads when this beam is used as a column with the following conditions :

(i) one end fixed and other end hinged

(ii) both the ends pin jointed.

(Annamalai University, 1990)

Sol. Given :

Length,  $L = 4 \text{ m} = 4000 \text{ mm}$

Uniformly distributed load,  $w = 30 \text{ kN/m} = 30,000 \text{ N/m}$

$$= \frac{30,000}{1000} \text{ N/mm} = 30 \text{ N/mm}$$

Deflection at the centre,  $\delta = 15 \text{ mm}$ .

For a simply supported beam, carrying U.D.L. over the whole span, the deflection at the centre is given by,

$$\delta = \frac{5}{384} \times \frac{w \times L^4}{EI}$$

$$15 = \frac{5}{384} \times \frac{30 \times 4000^4}{EI}$$

$$EI = \frac{5}{384} \times \frac{30 \times 4000^4}{15}$$

$$= \frac{5}{384} \times \frac{3 \times 256}{15} \times 10^{13} = \frac{2}{3} \times 10^{13} \text{ N mm}^2.$$

(i) Crippling load when the beam is used as a column with one end fixed and other end hinged.

The crippling load  $P$  for this case in terms of actual length is given by equation (19.4) as

$$P = \frac{2\pi^2 \times EI}{L_e^2}, \text{ where } l = \text{actual length} = 4000 \text{ mm}$$

$$= \frac{2 \times \pi^2 \times \frac{2}{3} \times 10^{13}}{4000^2} = 8224.5 \text{ kN. Ans.}$$

(ii) Crippling load when both the ends are pin-jointed

This is given by equation (19.1) in terms of actual length as

$$P = \frac{2\pi^2 \times EI}{l^2} \text{ where } l = \text{actual length} = 4000 \text{ mm}$$

$$= \frac{\pi^2 \times \frac{2}{3} \times 10^{13}}{4000^2} = 4112.25 \text{ kN. Ans.}$$

**Problem 19.5.** A solid round bar 4 m long and 5 cm in diameter was found to extend 4.6 mm under a tensile load of 50 kN. This bar is used as a strut with both ends hinged. Determine the buckling load for the bar and also the safe load taking factor of safety as 4.0.

Sol. Given :

Actual length of bar,  $L = 4 \text{ m} = 4000 \text{ mm}$

Dia. of bar,  $d = 5 \text{ cm}$

$$\therefore \text{Area of bar, } A = \frac{\pi}{4} \times 5^2 = 6.25\pi \text{ cm}^2 = 6.25\pi \times 10^2 \text{ mm}^2 = 625\pi \text{ mm}^2$$

Extension of bar,  $\delta L = 4.6 \text{ mm}$

Tensile load,  $W = 50 \text{ kN} = 50000 \text{ N}$ .

In this problem, the values of Young's modulus ( $E$ ) is not given. But it can be calculated from the given data.

$$\therefore \text{Young's modulus, } E = \frac{\text{Tensile stress}}{\text{Tensile strain}} = \frac{\left(\frac{\text{Tensile load}}{\text{Area}}\right)}{\left(\frac{\text{Extension of bar}}{\text{Length of bar}}\right)}$$

$$\left(\because \text{Stress} = \frac{\text{Load}}{\text{Area}} \text{ and strain} = \frac{\delta L}{L}\right)$$

$$= \frac{\left(\frac{W}{A}\right)}{\frac{\delta L}{L}} = \frac{W}{A} \times \frac{L}{\delta L} = \frac{50000}{625\pi} \times \frac{4000}{4.6} = 2.214 \times 10^4 \text{ N/mm}^2.$$

Since the strut is hinged at its both ends,

$\therefore$  Effective length,  $L_e = \text{Actual length} = 4000 \text{ mm}$

Let  $P =$  Crippling or buckling load.

Using equation (19.5), we get

$$P = \frac{\pi^2 EI}{L_e^2}$$

$$= \frac{\pi^2 \times 2.214 \times 10^4 \times \frac{\pi}{64} \times 5^4 \times 10^4}{4000 \times 4000}$$

$$= 4189.99 \text{ say } 4190 \text{ N. Ans.}$$

And safe load =  $\frac{\text{Crippling load}}{\text{Factor of safety}} = \frac{4190}{4} = 1047.5 \text{ N. Ans.}$

**Problem 19.6.** A hollow alloy tube 5 m long with external and internal diameters 40 mm and 25 mm respectively was found to extend 6.4 mm under a tensile load of 60 kN. Find the buckling load for the tube when used as a column with both ends pinned. Also find the safe load for the tube, taking a factor of safety = 4. (AMIE, Summer 1989)

Sol. Given :

Actual length,  $L = 5 \text{ m} = 5000 \text{ mm}$

External dia.,  $D = 40 \text{ mm}$

Internal dia.,  $d = 25 \text{ mm}$

Extension,  $\delta L = 6.4 \text{ mm}$

Tensile load,  $W = 60 \text{ kN} = 60,000 \text{ N}$

Safety factor = 4

$$\text{Cross-section area, } A = \frac{\pi}{4} (D^2 - d^2) = \frac{\pi}{4} (40^2 - 25^2) = 766 \text{ mm}^2$$

$$\begin{aligned} \text{Moment of inertia, } I &= \frac{\pi}{64} (D^4 - d^4) = \frac{\pi}{64} (40^4 - 25^4) \\ &= \frac{\pi}{64} (2560000 - 390625) = \frac{\pi}{64} \times 2169375 = 106500 \text{ mm}^4 \end{aligned}$$

The value of Young's modulus is obtained as given below

$$\begin{aligned} E &= \frac{\text{Tensile stress}}{\text{Tensile strain}} = \frac{\left(\frac{W}{A}\right)}{\left(\frac{\delta L}{L}\right)} \\ &= \frac{\left(\frac{60,000}{766}\right)}{\left(\frac{6.4}{5000}\right)} = \frac{60,000}{766} \times \frac{5000}{6.4} = 6.11945 \times 10^4 \text{ N/mm}^2 \end{aligned}$$

Since the column is pinned at both the ends.

∴ Effective length,  $L_e = \text{Actual length} = 5000 \text{ mm}$

Let  $P = \text{Buckling load}$

Using equation (19.5), we get

$$P = \frac{\pi^2 EI}{L_e^2} = \frac{\pi^2 \times 6.11945 \times 10^4 \times 106500}{5000^2} = 2573 \text{ N. Ans.}$$

$$\text{And safe load} = \frac{\text{Buckling load}}{\text{Factor of safety}} = \frac{2573}{4} = 643.2 \text{ N. Ans.}$$

**Problem 19.7.** Calculate the safe compressive load on a hollow cast iron column (one end rigidly fixed and other hinged) of 15 cm external diameter, 10 cm internal diameter and 10 m in length. Use Euler's formula with a factor of safety of 5 and  $E = 95 \text{ kN/mm}^2$ .

(AMIE, Winter 1981)

**Sol. Given :**

External dia.,  $D = 15 \text{ cm}$

Internal dia.,  $d = 10 \text{ cm}$

Actual length of column,  $l = 10 \text{ m} = 10000 \text{ mm}$

Factor of safety = 5.0

Young's modulus,  $E = 95 \text{ kN/mm}^2 = 95000 \text{ N/mm}^2$

Moment of inertia of hollow column,

$$\begin{aligned} I &= \frac{\pi}{64} (D^4 - d^4) = \frac{\pi}{64} (15^4 - 10^4) = \frac{\pi}{64} (50625 - 10000) \\ &= 1994.175 \text{ cm}^4 = 1994.175 \times 10^4 \text{ mm}^4 \end{aligned}$$

Since one end of the column is fixed and other end is hinged.

$$\therefore \text{Effective length, } L_e = \frac{l}{\sqrt{2}} = \frac{10000}{\sqrt{2}}$$

Let  $P = \text{Crippling load.}$

Using equation (19.5), we get

$$\begin{aligned} P &= \frac{\pi^2 EI}{L_e^2} \\ &= \frac{\pi^2 \times 95000 \times 1994.175 \times 10^4}{\left(\frac{10000}{\sqrt{2}}\right)^2} \quad \left(\because L = \frac{10000}{\sqrt{2}}\right) \\ &= \frac{\pi^2 \times 95000 \times 1994.175 \times 10^4 \times 2}{10000 \times 10000} = 373950 \text{ N} = 373.95 \text{ kN} \\ \text{But safe load} &= \frac{\text{Crippling load}}{\text{Factor of safety}} = \frac{373.95}{5} = 74.79 \text{ kN. Ans.} \end{aligned}$$

**Problem 19.8.** Determine Euler's crippling load for an I-section joist 40 cm × 20 cm × 1 cm and 5 m long which is used as a strut with both ends fixed. Take Young's modulus for the joist as  $2.1 \times 10^5 \text{ N/mm}^2$ .

**Sol. Given :**

Dimensions of I-section = 40 cm × 20 cm × 1 cm

Length actual,  $l = 5 \text{ m} = 5000 \text{ mm}$

Young's modulus,  $E = 2.1 \times 10^5 \text{ N/mm}^2$ .

Moment of inertia of the section about X-X axis,

$I_{XX} = \text{M.O.I. of rectangle of dimension}$

20 cm × 40 cm – M.O.I. of rectangle of dimension

[(20 – 1), (40 – 1 – 1)]

$$\begin{aligned} &= \frac{1}{12} b d^3 - \frac{1}{12} b_1 d_1^3 \\ &= \frac{1}{12} \times 20 \times 40^3 - \frac{1}{12} \times 19 \times 38^3 \\ &\quad (\because b_1 = 19, d_1 = 38) \\ &= 19786 \text{ cm}^4. \end{aligned}$$

Similarly the moment of inertia of the section about Y-Y axis

$I_{YY} = \text{M.O.I. of rectangle of dimension } (38 \times 1)$

+ M.O.I. of two rectangles of dimension (1 × 20)

$$\begin{aligned} &= \frac{1}{12} \times 38 \times 1^3 + 2 \times \frac{1}{12} \times 1 \times 20^3 \\ &= 3.166 \times 1333.33 = 1336.5 \text{ cm}^4. \end{aligned}$$

∴ Least value of the moment of inertia is about Y-Y axis.

∴  $I = 1336.5 \text{ cm}^4 = 1336.5 \times 10^4 \text{ mm}^4$

As both the ends of the strut are fixed

$$\therefore \text{Effective length, } L_e = \frac{l}{2} = \frac{5000}{2} = 2500 \text{ mm}$$

Let  $P = \text{Crippling load.}$

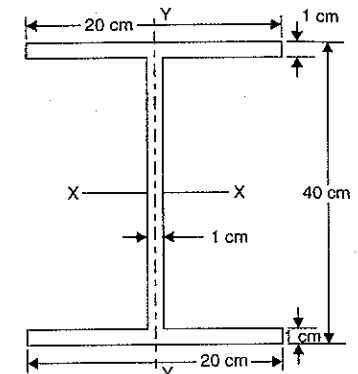

Fig. 19.9

Using equation (19.5), we get

$$P = \frac{\pi^2 EI}{L_e^2} = \frac{\pi^2 \times 2.1 \times 10^5 \times 1336.5 \times 10^4}{2500^3}$$

$$= 4432080 \text{ N} = 4.432 \text{ MN. Ans.}$$

**Problem 19.9.** Determine the crippling load for a T-section of dimensions 10 cm × 10 cm × 2 cm and of length 5 m when it is used as strut with both of its ends hinged. Take Young's modulus,  $E = 2.0 \times 10^5 \text{ N/mm}^2$ .

**Sol. Given :**

Dimensions of T-section = 10 cm × 10 cm × 2 cm

Length actual,  $l = 5 \text{ m} = 5000 \text{ mm}$

Young's modulus,  $E = 2.0 \times 10^5 \text{ N/mm}^2$ .

First of all, calculate the C.G. of the section. The given section is symmetrical about the axis Y-Y, hence the C.G. of the section will lie on Y-Y axis.

Let  $\bar{y}$  = Distance of C.G. of the section from bottom end.

For the flange, we have  $a_1 = 10 \times 2 = 20 \text{ cm}^2$

$y_1$  = Distance of C.G. of area  $a_1$  from the bottom end  
= 8 + 1 = 9 cm

For the web, we have  $a_2 = 8 \times 2 = 16 \text{ cm}^2$

$y_2$  = Distance of C.G. of area  $a_2$  from bottom end =  $\frac{8}{2} = 4 \text{ cm}$

Using the relation,  $\bar{y} = \frac{a_1 y_1 + a_2 y_2}{a_1 + a_2}$

$$= \frac{20 \times 9 + 16 \times 4}{20 + 16} = \frac{180 + 64}{36} = 6.777 \text{ cm}$$

Moment of inertia of the section about the axis X-X,

$$I_{XX} = \left( \frac{10 \times 8^3}{12} + 20 \times 2.223^2 \right) + \left( \frac{2 \times 8^3}{12} + 16 \times 2.777^2 \right)$$

$$= (6.667 + 98.834) + (85.333 + 123.387) = 314.221 \text{ cm}^4.$$

Moment of inertia of the section about the axis Y-Y,

$$I_{YY} = \frac{2 \times 10^3}{12} + \frac{8 \times 2^3}{12} = 166.67 + 5.33 = 172 \text{ cm}^4.$$

Least value of moment of inertia is about Y-Y axis

$\therefore I = 172 \text{ cm}^4 = 172 \times 10^4 \text{ mm}^4$

Since the strut is hinged at both of its end

$\therefore$  Effect length,  $L_e = l = 5000 \text{ mm}$

Let  $P$  = Crippling load

Using equation (19.5), we get

$$P = \frac{\pi^2 EI}{L_e^2} = \frac{\pi^2 \times 2.0 \times 10^5 \times 172 \times 10^4}{5000^3} = 135805.7 \text{ N. Ans.}$$

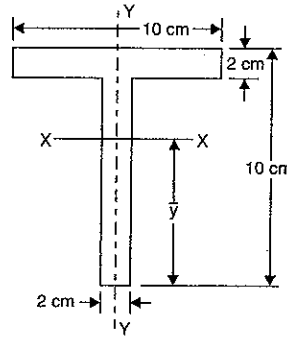

Fig. 19.10

**Problem 19.10.** Calculate the Euler's critical load for a strut of T-section, the flange width being 10 cm, overall depth 8 cm and both flange and stem 1 cm thick. The strut is 3 m long and is built in at both ends. Take  $E = 2 \times 10^5 \text{ N/mm}^2$ . (AMIE, Winter 1990)

**Sol. Given :**

Actual length,  $l = 3 \text{ m} = 3000 \text{ mm}$

Value of  $E = 2 \times 10^5 \text{ N/mm}^2$

The dimensions of T-section are shown in Fig. 19.10 (a). First of all, calculate the C.G. of the section. The given section is symmetrical about the y-y axis.

Hence the C.G. will lie on y-y axis.

Let  $\bar{y}$  = Distance of C.G. of the section from the bottom end.

For the flange  $a_1$  = Area of flange =  $10 \times 1 = 10 \text{ cm}^2$

$y_1$  = Distance of C.G. of area  $a_1$  from the bottom end

$$= 7 + \frac{1}{2} = 7.5 \text{ cm.}$$

For the stem or web,  $a_2$  = Area of stem =  $7 \times 1 = 7 \text{ cm}^2$

$y_2$  = Distance of C.G. of area  $a_2$  from the bottom end

$$= \frac{7}{2} = 3.5 \text{ cm}$$

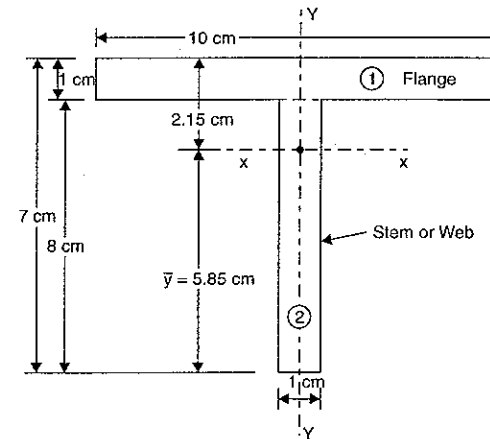

Fig. 19.10 (a)

Now using the relation,  $\bar{y} = \frac{a_1 \times y_1 + a_2 \times y_2}{a_1 + a_2} = \frac{10 \times 7.5 + 7 \times 3.5}{10 + 7}$

$$= \frac{75 + 24.5}{17} = \frac{99.5}{17} = 5.85 \text{ cm.}$$

Now calculate the moment of inertia about x-x axis and y-y axis.

$$I_{XX} = \left[ \frac{10 \times 1^3}{12} + a_1 \times (2.15 - 0.5)^2 \right] + \left[ \frac{1 \times 7^3}{12} + a_2 \times (5.85 - 3.5)^2 \right]$$

$$= \left[ \frac{10}{12} + 10 \times 1.65^2 \right] + \left[ \frac{343}{12} + 7 \times 2.35^2 \right] = 95.298 \text{ cm}^4$$

and

$$I_{YY} = \frac{1 \times 10^3}{12} + \frac{7 \times 1^3}{12} = 83.33 + 0.583 = 83.916 \text{ cm}^4.$$

The least value of moment of inertia is about y-axis.

$$\therefore I = I_{YY} = 83.916 \text{ cm}^4 = 839160 \text{ mm}^4.$$

As the strut is fixed at both ends, hence its effective length ( $L_e$ ) will be half of its actual length.

$$\therefore L_e = \frac{l}{2} = \frac{3000}{2} = 1500 \text{ mm}$$

Let  $P$  = Euler's critical load.

$$\text{Using equation (19.5), } P = \frac{\pi^2 EI}{L_e^2} = \frac{\pi^2 \times 2 \times 10^5 \times 839160}{1500^3} \\ = 736190 \text{ N} = \mathbf{736.19 \text{ kN. Ans.}}$$

**Problem 19.11.** A strut length  $l$ , moment of inertia of cross-section =  $I$  uniform throughout and modulus of material =  $E$ , is fixed at its lower end, and its upper end is elastically supported laterally by a spring of stiffness  $k$ . Show from the first principles that the crippling load  $P$  is given by  $\frac{\tan \alpha l}{\alpha l} = 1 - \frac{P}{kl}$ , where  $\alpha^2 = \frac{P}{EI}$ .

(AMIE, Summer 1984)

Sol. Given :

Length of strut	= $l$
Moment of inertia	= $I$
Young's modulus	= $E$
Stiffness of spring	= $k$
Crippling load	= $P$ .

The strut is shown in Fig. 19.11 in which

$H$  = Lateral force due to spring of stiffness  $k$

$a$  = Deflection of the end  $B$

Then  $H$  = Stiffness of spring  $\times$  Deflection of end  $B$   
 $= k \times a$ . ... (i)

Consider any section at a distance  $x$  from the fixed end  $A$ .

Let  $y$  = Deflection at the section.

Then moment at the section = Moment due to crippling load

$$= P(a - y) - H(l - x) = P \cdot a - P \cdot y - H(l - x)$$

But moment is also =  $EI \frac{d^2 y}{dx^2}$

$\therefore$  Equating the two moments, we get

$$EI \frac{d^2 y}{dx^2} = P \cdot a - P \cdot y - H(l - x)$$

$$EI \frac{d^2 y}{dx^2} + P \cdot y = P \cdot a - H(l - x)$$

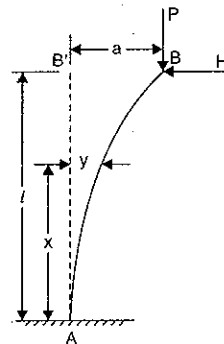

Fig. 19.11

$$\text{or } \frac{d^2 y}{dx^2} + \frac{P}{EI} \cdot y = \frac{P}{EI} \cdot a - \frac{H}{EI} (l - x) \quad \text{(Dividing by } EI) \quad \dots (A)$$

$$= \frac{P}{EI} \cdot a - \frac{H}{P} \cdot \frac{P}{EI} (l - x)$$

$$= \frac{P}{EI} \cdot a - \frac{P}{EI} \cdot \frac{H}{P} (l - x) = \frac{P}{EI} \left[ a - \frac{H}{P} (l - x) \right]$$

The solution\* of the above differential equation is

$$y = C_1 \cdot \cos \left( x \cdot \sqrt{\frac{P}{EI}} \right) + C_2 \cdot \sin \left( x \cdot \sqrt{\frac{P}{EI}} \right) + a - \frac{H}{P} (l - x)$$

$$= C_1 \cdot \cos (x \cdot \alpha) + C_2 \cdot \sin (x \cdot \alpha) + a - \frac{H}{P} (l - x)$$

$$\left( \because \alpha^2 = \frac{P}{EI} \therefore \alpha = \sqrt{\frac{P}{EI}} \right) \dots (ii)$$

where  $C_1$  and  $C_2$  are constant of integration and their values are obtained from boundary conditions. The boundary conditions are :

(i) For fixed end  $A$ ,  $x = 0$  and  $y = 0$  also  $\frac{dy}{dx} = 0$

(ii) At  $x = l$ ,  $y = a$ .

Substituting the values  $x = 0$ ,  $y = 0$  in equation (ii), we get

$$0 = C_1 \cdot 1 + C_2 \cdot 0 + a - \frac{H}{P} (l - 0) \quad (\because \cos 0 = 1, \sin 0 = 0)$$

$$= C_1 + a - \frac{H}{P} l$$

$$\therefore C_1 = -a + \frac{H}{P} l \quad \dots (iii)$$

Differentiating equation (ii) w.r.t.  $x$ , we get

$$\frac{dy}{dx} = -C_1 \cdot \alpha \cdot \sin (x \cdot \alpha) + C_2 \cdot \alpha \cdot \cos (x \cdot \alpha) + 0 - \frac{H}{P} (-1)$$

$$= -C_1 \cdot \alpha \cdot \sin (x \cdot \alpha) + C_2 \cdot \alpha \cdot \cos (x \cdot \alpha) + \frac{H}{P}$$

\*The equation (A) can be written as

$$\frac{d^2 y}{dx^2} + \alpha^2 \cdot y = \alpha^2 \cdot a - \frac{H}{EI} (l - x) \quad \text{where } \alpha = \frac{P}{EI} \quad \text{or } \alpha = \sqrt{\frac{P}{EI}}$$

The complete solution of this equation is

$$y = C_1 \cos (\alpha \cdot x) + C_2 \sin (\alpha \cdot x) + \frac{\alpha^2 \cdot a - \frac{H}{EI} (l - x)}{\alpha^2}$$

$$= C_1 \cos \left( \sqrt{\frac{P}{EI}} \cdot x \right) + C_2 \sin \left( \sqrt{\frac{P}{EI}} \cdot x \right) + a - \frac{H(l - x)}{EI \times \frac{P}{EI}}$$

$$= C_1 \cos \left( x \times \sqrt{\frac{P}{EI}} \right) + C_2 \sin \left( x \times \sqrt{\frac{P}{EI}} \right) + a - \frac{H}{P} (l - x)$$

Substituting the values at  $x = 0$ ,  $\frac{dy}{dx} = 0$ , in the above equation, we get

$$0 = -C_1 \cdot \alpha \cdot 0 + C_2 \cdot \alpha \cdot 1 + \frac{H}{P} \quad (\because \sin 0 = 0, \cos 0 = 1)$$

$$= C_2 \cdot \alpha + \frac{H}{P}$$

$$\therefore C_2 = -\frac{H}{\alpha P} \quad \dots(iv)$$

Substituting the values of  $C_1$  and  $C_2$  in equation (ii), we get

$$y = -\left(a - \frac{H}{P}l\right) \cdot \cos(x\alpha) - \frac{H}{\alpha P} \sin(x\alpha) + a - \frac{H}{P}(l-x) \quad \dots(v)$$

At the end  $B$ ,  $x = l$  and  $y = a$ .

Substituting these values in equation (v), we get

$$a = -\left(a - \frac{H}{P}l\right) \cdot \cos(l\alpha) - \frac{H}{\alpha P} \sin(l\alpha) + a - \frac{H}{P}(l-l)$$

$$= -\left(a - \frac{H}{P}l\right) \cdot \cos(l\alpha) - \frac{H}{\alpha P} \sin(l\alpha) + a$$

$$\text{or } a + \left(a - \frac{H}{P}l\right) \cos(l\alpha) - a = -\frac{H}{\alpha P} \sin(l\alpha)$$

$$\text{or } \left(a - \frac{H}{P}l\right) \cos(l\alpha) = -\frac{H}{\alpha P} \sin(l\alpha)$$

$$\text{or } \frac{\sin(l\alpha)}{\cos(l\alpha)} = \frac{\left(a - \frac{H}{P}l\right)}{-\frac{H}{\alpha P}}$$

$$\text{or } \tan(l\alpha) = -\left(a - \frac{H}{P}l\right) \cdot \frac{\alpha P}{H}$$

$$\text{or } \tan(l\alpha) = -\frac{\alpha \alpha \cdot P}{H} + \frac{H}{P}l \cdot \frac{\alpha P}{H}$$

$$= -\frac{\alpha \alpha \cdot P}{H} + l\alpha = -\frac{\alpha \alpha \cdot P}{k \cdot a} + \alpha l \quad [\because H = k \cdot a \text{ from equation (i)}]$$

$$= -\frac{\alpha \cdot P}{k} + \alpha l$$

Dividing by  $\alpha l$ , we get

$$\frac{\tan(\alpha l)}{\alpha l} = -\frac{\alpha \cdot P}{k \cdot \alpha \cdot l} + 1 = -\frac{P}{k \cdot l} + 1$$

$$\text{or } \frac{\tan(\alpha l)}{\alpha l} = 1 - \frac{P}{kl} \quad \text{Ans.}$$

**Problem 19.12.** Determine the ratio of buckling strengths of two columns one hollow and the other solid. Both are made of the same material and have the same length, cross-sectional area and end conditions. The internal diameter of hollow column is half of its external diameter. (AMIE, Winter 1982, Summer 1985)

**Sol. Given :**

Let  $d$  = Dia. of solid column

$D$  = External dia. of hollow column

$\therefore$  Internal dia. of hollow shaft =  $\frac{D}{2}$

Both the shafts are made of the same material and have the same length, cross-sectional area and end conditions. As areas of solid and hollow shafts are equal.

$\therefore$  Area of solid shaft = Area of hollow shaft

$$\text{or } \frac{\pi}{2} d^2 = \frac{\pi}{2} \left[ D^2 - \left(\frac{D}{2}\right)^2 \right] \text{ or } d^2 = \left[ D^2 - \frac{D^2}{4} \right] = \frac{3D^2}{4}$$

$$\therefore d = \frac{\sqrt{3}D}{2} \quad \dots(i)$$

Buckling load of a column as given by Euler's formula is

$$P = \frac{\pi^2 EI}{L^2} \quad [\text{see equation (19.5)}]$$

As the shafts are having the same length, same material, same cross-sectional areas and same end conditions. Hence the value of  $A$ ,  $E$  and  $L$  for both shafts are same.

$\therefore P \propto I \quad (\because A, E \text{ and } L \text{ are same}) \dots(ii)$

Let  $P_1$  = Buckling load of the hollow column

$P_2$  = Buckling load of solid column

$I_1$  = Least moment of inertia of the hollow column

$$= \frac{\pi}{64} \left[ D^4 - \left(\frac{D}{2}\right)^4 \right] = \frac{\pi}{64} \left[ D^4 - \frac{D^4}{16} \right] = \frac{\pi}{64} \times \frac{15}{16} D^4$$

$I_2$  = Least moment of inertia of the solid column

$$= \frac{\pi}{64} d^4.$$

From equation (ii), we have

$$\frac{P_1}{I_1} = \frac{P_2}{I_2} \quad \text{or} \quad \frac{P_1}{P_2} = \frac{I_1}{I_2}$$

$$= \frac{\pi \times \frac{15}{64} D^4}{\frac{\pi}{64} d^4} \quad \left( \because I_1 = \frac{\pi}{64} \times \frac{15}{16} D^4, I_2 = \frac{\pi}{64} d^4 \right)$$

$$= \frac{15 D^4}{16 d^4} = \frac{15}{16} \frac{D^4}{\left(\frac{\sqrt{3}D}{2}\right)^4} \quad \left( \because d = \frac{\sqrt{3}D}{2} \right)$$

$$= \frac{15}{16} \times \frac{D^4}{\frac{9}{16} D^4} = \frac{15}{9} = \frac{5}{3} = 1.667$$

$$\frac{\text{Buckling load of hollow column}}{\text{Buckling load of solid column}} = 1.667 \quad \text{Ans.}$$



**Problem 19.12 (a).** Using Euler's formula, calculate the critical stresses for a series of struts having slenderness ratio of 40, 80, 120, 160 and 200 under the following conditions :

(i) both ends hinged and

(ii) both ends fixed.

Take  $E = 2.05 \times 10^5 \text{ N/mm}^2$ .

(Annamalai University, 1990)

**Sol.** Given :

(i) Critical stresses when both ends hinged

Slenderness ratios,  $\frac{l}{k} = 40, 80, 120, 160$  and  $200$

The critical stress or crippling stress is given by equation (19.7).

$$\therefore \text{Critical stress} = \frac{\pi^2 \times E}{\left(\frac{L_e}{k}\right)^2}$$

where  $L_e$  = Effective length

But for both ends hinged,  $L_e = l$

where  $l$  = actual length.

$$\therefore \text{Critical stress} = \frac{\pi^2 E}{\left(\frac{l}{k}\right)^2} \quad (\because L = l) \dots(ii)$$

When  $\frac{l}{k} = 40$ , the critical stress becomes as

$$= \frac{\pi^2 \times E}{40^2} = \frac{\pi^2 \times 2.05 \times 10^5}{1600} = 1264.54 \text{ N/mm}^2. \text{ Ans.}$$

When  $\frac{l}{k} = 80$ , the critical stress becomes as

$$= \frac{\pi^2 \times E}{80^2} = \frac{\pi^2 \times 2.05 \times 10^5}{6400} = 316.135 \text{ N/mm}^2. \text{ Ans.}$$

When  $\frac{l}{k} = 120$ , the critical stress becomes as

$$= \frac{\pi^2 \times E}{120^2} = \frac{\pi^2 \times 2.05 \times 10^5}{14400} = 140.5 \text{ N/mm}^2. \text{ Ans.}$$

When  $\frac{l}{k} = 160$ , the critical stress

$$= \frac{\pi^2 \times E}{160^2} = \frac{\pi^2 \times 2.05 \times 10^5}{25600} = 79.03 \text{ N/mm}^2. \text{ Ans.}$$

When  $\frac{l}{k} = 200$ , the critical stress

$$= \frac{\pi^2 \times E}{200^2} = \frac{\pi^2 \times 2.05 \times 10^5}{40000} = 50.58 \text{ N/mm}^2. \text{ Ans.}$$

(ii) Critical stresses when both ends fixed

Using equation (19.7),

$$\text{Crippling or critical stress} = \frac{\pi^2 \times E}{\left(\frac{L_e}{k}\right)^2}$$

When both ends fixed,  $L_e = \frac{l}{2}$

$$\therefore \text{Critical stress} = \frac{\pi^2 \times E}{\left(\frac{l}{2k}\right)^2} = \frac{4\pi^2 \times E}{\left(\frac{l}{k}\right)^2}$$

When  $\frac{l}{k} = 40$ , the critical stress becomes as

$$= \frac{4\pi^2 \times E}{\left(\frac{l}{k}\right)^2} = \frac{4 \times \pi^2 \times 2.05 \times 10^5}{40^2} \\ = \frac{4 \times \pi^2 \times 2.05 \times 10^5}{1600} = 5058.16 \text{ N/mm}^2. \text{ Ans.}$$

When  $\frac{l}{k} = 80$ , the critical stress becomes as

$$= \frac{4\pi^2 \times E}{\left(\frac{l}{k}\right)^2} = \frac{4 \times \pi^2 \times 2.05 \times 10^5}{80^2} = 1264.54 \text{ N/mm}^2. \text{ Ans.}$$

When  $\frac{l}{k} = 120$ , the critical stress becomes as

$$= \frac{4\pi^2 \times E}{120^2} = \frac{4 \times \pi^2 \times 2.05 \times 10^5}{120^2} = 562.02 \text{ N/mm}^2. \text{ Ans.}$$

When  $\frac{l}{k} = 160$ , the critical stress becomes as

$$= \frac{4\pi^2 \times 2.05 \times 10^5}{160^2} = 316.135 \text{ N/mm}^2. \text{ Ans.}$$

When  $\frac{l}{k} = 200$ , the critical stress becomes as

$$= \frac{4\pi^2 \times 2.05 \times 10^5}{200^2} = 202.32 \text{ N/mm}^2. \text{ Ans.}$$

### 19.11. RANKINE'S FORMULA

In Art. 19.10, we have learnt that Euler's formula gives correct results only for very long columns. But what happens when the column is a short or the column is not a very long. On the basis of results of experiments performed by Rankine, he established an empirical formula which is applicable to all columns whether they are short or long. The empirical formula given by Rankine is known as Rankine's formula, which is given as

$$\frac{1}{P} = \frac{1}{P_C} + \frac{1}{P_E} \quad \dots(i)$$

where  $P$  = Crippling load by Rankine's formula

$P_C$  = Crushing load =  $\sigma_c \times A$

$\sigma_c$  = Ultimate crushing stress

$A$  = Area of cross-section

$P_E$  = Crippling load by Euler's formula

$$= \frac{\pi^2 EI}{L_e^2}, \text{ in which } L_e = \text{Effective length}$$

For a given column material the crushing stress  $\sigma_c$  is a constant. Hence the crushing load  $P_C$  (which is equal to  $\sigma_c \times A$ ) will also be constant for a given cross-sectional area of the column. In equation (i),  $P_C$  is constant and hence value of  $P$  depends upon the value of  $P_E$ . But for a given column material and given cross-sectional area, the value of  $P_E$  depends upon the effective length of the column.

(i) If the column is a short, which means the value of  $L_e$  is small, then the value of  $P_E$  will be large. Hence the value of  $\frac{1}{P_E}$  will be small enough and is negligible as compared to

the value of  $\frac{1}{P_C}$ . Neglecting the value of  $\frac{1}{P_E}$  in equation (i), we get

$$\frac{1}{P} \rightarrow \frac{1}{P_C} \text{ or } P \rightarrow P_C$$

Hence the crippling load by Rankine's formula for a short column is approximately equal to crushing load. In Art. 19.2.1 also we have seen that short columns fail due to crushing.

(ii) If the column is long, which means the value of  $L_e$  is large. Then the value of  $P_E$  will be small and the value of  $\frac{1}{P_E}$  will be large enough compared with  $\frac{1}{P_C}$ . Hence the value of  $\frac{1}{P_C}$  may be neglected in equation (i).

$$\frac{1}{P} = \frac{1}{P_E} \text{ or } P \rightarrow P_E$$

Hence the crippling load by Rankine's formula for long columns is approximately equal to crippling load given by Euler's formula.

Hence the Rankine's formula  $\frac{1}{P} = \frac{1}{P_C} + \frac{1}{P_E}$  gives satisfactory results for all lengths of columns, ranging from short to long columns.

$$\text{Now the Rankine's formula is } \frac{1}{P} = \frac{1}{P_C} + \frac{1}{P_E} = \frac{P_E + P_C}{P_C \cdot P_E}$$

Taking reciprocal to both sides, we have

$$P = \frac{P_C \cdot P_E}{P_E + P_C} = \frac{P_C}{1 + \frac{P_C}{P_E}}$$

(Dividing the numerator and denominator by  $P_E$ )

$$= \frac{\sigma_c \times A}{1 + \frac{\sigma_c \cdot A}{\left(\frac{\pi^2 EI}{L_e^2}\right)}} \quad \left( \because P_C = \sigma_c \cdot A \text{ and } P_E = \frac{\pi^2 EI}{L_e^2} \right)$$

But  $I = Ak^2$ , where  $k$  = least radius of gyration

$\therefore$  The above equation becomes as

$$P = \frac{\sigma_c \cdot A}{1 + \frac{\sigma_c \cdot A \cdot L_e^2}{\pi^2 E \cdot Ak^2}} = \frac{\sigma_c \cdot A}{1 + \frac{\sigma_c}{\pi^2 E} \cdot \left(\frac{L_e}{k}\right)^2}$$

$$= \frac{\sigma_c \cdot A}{1 + a \cdot \left(\frac{L_e}{k}\right)^2} \quad \dots(19.9)$$

where  $a = \frac{\sigma_c}{\pi^2 E}$  and is known as Rankine's constant.

The equation (19.9) gives crippling load by Rankine's formula. As the Rankine formula is empirical formula, the value of 'a' is taken from the results of the experiments and is not calculated from the values of  $\sigma_c$  and  $E$ .

The values of  $\sigma_c$  and  $a$  for different columns material are given below in Table 19.2.

TABLE 19.2

S. No.	Material	$\sigma_c$ in N/mm <sup>2</sup>	$a$
1.	Wrought Iron	250	$\frac{1}{9000}$
2.	Cast Iron	550	$\frac{1}{1600}$
3.	Mild Steel	320	$\frac{1}{7500}$
4.	Timber	50	$\frac{1}{750}$

**Problem 19.13.** The external and internal diameter of a hollow cast iron column are 5 cm and 4 cm respectively. If the length of this column is 3 m and both of its ends are fixed, determine the crippling load using Rankine's formula. Take the values of  $\sigma_c = 550 \text{ N/mm}^2$  and

$a = \frac{1}{1600}$  in Rankine's formula.

**Sol.** Given :

External dia.,  $D = 5 \text{ cm}$

Internal dia.,  $d = 4 \text{ cm}$

$$\therefore \text{Area, } A = \frac{\pi}{4} (5^2 - 4^2) = 2.25\pi \text{ cm}^2 = 2.25\pi \times 10^2 \text{ mm}^2 = 225\pi \text{ mm}^2$$

$$\text{Moment of Inertia, } I = \frac{\pi}{64} [5^4 - 4^4] = 5.7656 \pi \text{ cm}^4$$

$$= 5.7656\pi \times 10^4 \text{ mm}^4 = 57656\pi \text{ mm}^4$$

∴ Least radius of gyration,

$$k = \sqrt{\frac{I}{A}} = \sqrt{\frac{57656\pi}{225\pi}} = 25.625 \text{ mm}$$

Length of column,  $l = 3 \text{ m} = 3000 \text{ mm}$

As both the ends are fixed,

$$\therefore \text{Effective length, } L_e = \frac{l}{2} = \frac{3000}{2} = 1500 \text{ mm}$$

Crushing stress,  $\sigma_c = 550 \text{ N/mm}^2$

Rankine's constant,  $a = \frac{1}{1600}$

Let  $P$  = Crippling load by Rankine's formula

Using equation (19.9), we have

$$P = \frac{\sigma_c \cdot A}{1 + \left(\frac{L_e}{k}\right)^2} = \frac{550 \times 225\pi}{1 + \frac{1}{1600} \times \left(\frac{1500}{25.625}\right)^2}$$

$$= \frac{550 \times 225\pi}{3.1415} = 123750 \text{ N. Ans.}$$

**Problem 19.14.** A hollow cylindrical cast iron column is 4 m long with both ends fixed. Determine the minimum diameter of the column if it has to carry a safe load of 250 kN with a factor of safety of 5. Take the internal diameter as 0.8 times the external diameter. Take

$\sigma_c = 550 \text{ N/mm}^2$  and  $a = \frac{1}{1600}$  in Rankine's formula.

(AMIE, Winter 1983)

**Sol.** Given :

Length of column,  $l = 4 \text{ m} = 4000 \text{ mm}$

End conditions = Both ends fixed

$$\therefore \text{Effective length, } L_e = \frac{l}{2} = \frac{4000}{2} = 2000 \text{ mm}$$

Safe load, = 250 kN

Factor of safety, = 5

Let External dia., =  $D$

Internal dia. =  $0.8 \times D$

Crushing stress,  $\sigma_c = 550 \text{ N/mm}^2$

Value of 'a' =  $\frac{1}{1600}$  in Rankine's formula

$$\text{Now factor of safety} = \frac{\text{Crippling load}}{\text{Safe load}} \quad \text{or} \quad 5 = \frac{\text{Crippling load}}{250}$$

$$\therefore \text{Crippling load, } P = 5 \times 250 = 1250 \text{ kN} = 1250000 \text{ N}$$

$$\text{Area of column, } A = \frac{\pi}{4} [D^2 - (0.8D)^2]$$

$$= \frac{\pi}{4} [D^2 - 0.64D^2] = \frac{\pi}{4} \times 0.36D^2 = \pi \times 0.09D^2$$

$$\text{Moment of Inertia, } I = \frac{\pi}{64} [D^4 - (0.8D)^4] = \frac{\pi}{64} [D^4 - 0.4096D^4]$$

$$= \frac{\pi}{64} \times 0.5904 \times D^4 = 0.009225 \times \pi \times D^4$$

But  $I = A \times k^2$ , where  $k$  is radius of gyration

$$\therefore k = \sqrt{\frac{I}{A}} = \sqrt{\frac{0.009225 \times \pi D^4}{\pi \times 0.09 \times D^2}} = 0.32D$$

$$\text{Now using equation (19.9), } P = \frac{\sigma_c \cdot A}{1 + a \left(\frac{L_e}{k}\right)^2}$$

$$\text{or } 1250000 = \frac{550 \times \pi \times 0.09 D^2}{1 + \frac{1}{1600} \times \left(\frac{2000}{0.32D}\right)^2} \quad (\because A = \pi \times 0.09D^2)$$

$$\frac{1250000}{550 \times \pi \times 0.09} = \frac{D^2}{1 + \frac{24414}{D^2}} \quad \text{or} \quad 8038 = \frac{D^2 \times D^2}{D^2 + 24414}$$

$$\text{or } 8038D^2 + 8038 \times 24414 = D^4 \text{ or } D^4 - 8038D^2 - 8038 \times 24414 = 0$$

$$\text{or } D^4 - 8038D^2 - 196239700 = 0.$$

The above equation is a quadratic equation in  $D^2$ . The solution is

$$\therefore D^2 = \frac{8038 \pm \sqrt{8038^2 + 4 \times 1 \times 196239700}}{2}$$

$$\left( \text{Roots} = \frac{-b \pm \sqrt{b^2 - 4ac}}{2a} \right)$$

$$= \frac{8038 \pm \sqrt{646094 + 784958800}}{2} = \frac{8038 \pm 29147}{2}$$

$$= \frac{8038 + 29147}{2} \quad (\text{The other root is not possible})$$

$$= 18592.5 \text{ mm}^2$$

$$\therefore D = \sqrt{18592.5} = 136.3 \text{ mm}$$

∴ External diameter = 136.3 mm. Ans.

Internal diameter =  $0.8 \times 136.3 = 109 \text{ mm}$ . Ans.

**Problem 19.15.** A 1.5 m long column has a circular cross-section of 5 cm diameter. One of the ends of the column is fixed in direction and position and other end is free. Taking factor of safety as 3, calculate the safe load using :

(a) Rankine's formula, take yield stress,  $\sigma_c = 560 \text{ N/mm}^2$  and  $a = \frac{1}{1600}$  for pinned ends.

(b) Euler's formula, Young's modulus for C.I. =  $1.2 \times 10^5 \text{ N/mm}^2$ .

(AMIE, Summer 1976)

**Sol.** Given :

Length,  $l = 1.5 \text{ m} = 1500 \text{ mm}$

Diameter,  $d = 5 \text{ cm}$

$$\therefore \text{Area, } A = \frac{\pi}{4} \times 5^2 = 19.635 \text{ cm}^2 = 19.635 \times 10^2 \text{ mm}^2$$

$$\text{Moment of inertia, } I = \frac{\pi}{64} \times 5^4 = 30.7 \text{ cm}^4 = 30.7 \times 10^4 \text{ mm}^4$$

$$\text{Least radius of gyration, } k = \sqrt{\frac{I}{A}} = \sqrt{\frac{30.7 \times 10^4}{19.635 \times 10^2}} = 12.5 \text{ mm.}$$

End conditions = One end is fixed and other end is free.

$$\therefore \text{Effective length, } L_e = 2l = 2 \times 1500 = 3000 \text{ mm}$$

Factor of safety = 3.

(a) Safe load by Rankine's formula

$$\text{Yield stress, } \sigma_c = 560 \text{ N/mm}^2$$

$$\text{Rankine's constant, } a = \frac{1}{1600}$$

Let  $P$  = Crippling load by Rankine's formula

Using equation (19.9), we have

$$P = \frac{\sigma_c \times A}{1 + a \left( \frac{L_e}{k} \right)^2}$$

$$= \frac{560 \times 1963.5}{1 + \frac{1}{1600} \times \left( \frac{3000}{12.5} \right)^2} \quad (\because L = 3000 \text{ mm and } k = 12.5)$$

$$= 29708.1 \text{ N}$$

$$\therefore \text{Safe load} = \frac{\text{Crippling load}}{\text{Factor of safety}}$$

$$= \frac{29708.1}{3} = 9902.7 \text{ N. Ans.}$$

(b) Safe load by Euler's formula

$$\text{Young's Modulus, } E = 1.2 \times 10^5 \text{ N/mm}^2$$

Let  $P$  = Crippling load by Euler's formula

$$\text{Using equation (19.5), } P = \frac{\pi^2 EI}{L_e^2}$$

$$= \frac{\pi^2 \times 1.2 \times 10^5 \times 30.7 \times 10^4}{3000^2} \quad (\because L = 3000 \text{ mm})$$

$$= 40200 \text{ N}$$

$$\therefore \text{Safe load} = \frac{\text{Crippling load}}{\text{Factor of safety}} = \frac{40200}{3} = 13400 \text{ N. Ans.}$$

**Problem 19.16.** A short length of tube, 4 cm internal diameter and 5 cm external diameter, failed in compression at a load of 240 kN. When a 2 metre length of the same tube was tested as a strut with fixed ends, the load at failure was 158 kN. Assuming that  $\sigma_c$  in Rankine's formula is given by the first test, find the value of the constant  $a$  in the same formula. What will be the crippling load of this tube if it is used as a strut 3 m long with one end fixed and the other hinged?  
(AMIE, Summer 1983)

Sol. Given :

External diameter,  $D = 5 \text{ cm}$

Internal diameter,  $d = 4 \text{ cm}$

$$\therefore \text{Area, } A = \frac{\pi}{4} (5^2 - 4^2) = \frac{9\pi}{4} = 2.25 \pi \text{ cm}^2 = 225 \pi \text{ mm}^2$$

$$\text{Moment of inertia, } I = \frac{\pi}{64} [5^4 - 4^4] = \frac{\pi}{64} (625 - 256)$$

$$= 5.7656 \times \pi \text{ cm}^4 = 57656 \pi \text{ mm}^4$$

$$\therefore \text{Least radius of gyration, } k = \sqrt{\frac{I}{A}} = \sqrt{\frac{57656 \pi}{225 \pi}} = 16 \text{ mm}$$

$$\text{Crushing load} = 240 \text{ kN.}$$

The value of  $\sigma_c$  in Rankine's formula is given by the crushing load of 240 kN.

$$\therefore \text{The value of } \sigma_c = \frac{\text{Crushing load of 240 kN}}{\text{Area}}$$

$$= \frac{240}{225 \pi} = 0.3395 \text{ kN/mm}^2$$

Length of the strut,  $l = 2 \text{ m} = 2000 \text{ mm}$

End condition = Both the ends are fixed

$$\therefore \text{Effective length, } L_e = \frac{l}{2} = \frac{2000}{2} = 1000 \text{ mm}$$

Crushing load of strut,  $P = 158 \text{ kN.}$

(i) Value of constant 'a'

Let  $a$  = Value of Rankine's constant

Using equation (19.9), we have

$$P = \frac{\sigma_c \cdot A}{1 + a \left( \frac{L_e}{k} \right)^2}$$

$$158 = \frac{0.33953 \times 225 \pi}{1 + a \left( \frac{1000}{16} \right)^2} = \frac{239.99}{1 + 3906.25 \times a}$$

or

$$1 + 3906.25 \times a = \frac{239.99}{158} = 1.5189.$$

$$\therefore a = \frac{1.5189 - 1.0}{3906.25} = 0.0001328 = \frac{1}{7530}. \text{ Ans.}$$

(ii) Crippling load for the strut of length 3 m when one end is fixed and other is hinged

Actual length,  $l = 3 \text{ m} = 3000 \text{ mm}$

End conditions = One end fixed and other is hinged

$$\therefore \text{Effective length, } L_e = \frac{l}{\sqrt{2}} = \frac{3000}{\sqrt{2}}$$

Let  $P$  = Crippling load.

Using equation (19.9),

$$P = \frac{\sigma_c \cdot A}{1 + a \cdot \left(\frac{L_e}{k}\right)^2}$$

$$= \frac{0.33953 \times 225\pi}{1 + \frac{1}{7530} \times \left(\frac{3000}{\sqrt{2} \times 16}\right)^2} \quad \left(\because k = 16, a = \frac{1}{7530}\right)$$

$$= \frac{0.33953 \times 225 \times \pi}{1 + 2.3344} = 71.97 \text{ kN. Ans.}$$

**Problem 19.17.** Find the Euler crushing load for a hollow cylindrical cast iron column 20 cm external diameter and 25 mm thick if it is 6 m long and is hinged at both ends. Take  $E = 1.2 \times 10^5 \text{ N/mm}^2$ .

Compare the load with the crushing load as given by the Rankine's formula, taking  $\sigma_c = 550 \text{ N/mm}^2$  and  $a = \frac{1}{1600}$ ; for what length of the column would these two formulae give the same crushing load? (AMIE, Winter 1984)

**Sol.** Given :

External dia.,  $D = 20 \text{ cm}$

Thickness,  $t = 25 \text{ mm} = 2.5 \text{ cm}$

$\therefore$  Internal dia.,  $d = (D - 2 \times t) = 20 - 2 \times 2.5 = 15 \text{ cm.}$

Area,  $A = \frac{\pi}{4} (20^2 - 15^2) = \frac{175\pi}{4} = 137.44 \text{ cm}^2 = 13744 \text{ mm}^2$

Moment of inertia,  $I = \frac{\pi}{64} [20^4 - 15^4] = \frac{\pi}{64} (160000 - 50625)$   
 $= 5368.93 \text{ cm}^4 = 53689300 \text{ mm}^4$

$\therefore$  Least radius of gyration,

$$k = \sqrt{\frac{I}{A}} = \sqrt{\frac{53689300}{15744}} = 62.5 \text{ mm}$$

Length of column,  $l = 6 \text{ m} = 6000 \text{ mm}$

End conditions = Both ends are hinged

$\therefore$  Effective length,  $L_e = l = 6000 \text{ mm}$

Value of  $E = 1.2 \times 10^5 \text{ N/mm}^2$ .

Euler's crushing load is given by equation (19.5),

$$P = \frac{\pi^2 EI}{L_e^2}$$

$$= \frac{\pi^2 \times 1.2 \times 10^5 \times 53689300}{6000^2} = 1766307 \text{ N. Ans.}$$

Crushing load by Rankine's formula

The value of  $\sigma_c = 550 \text{ N/mm}^2$

Value of  $a = \frac{1}{1600}$

Let  $P =$  Crushing load by Rankine's formula

Using equation (19.9),

$$P = \frac{\sigma_c \cdot A}{1 + a \cdot \left(\frac{L_e}{k}\right)^2} = \frac{550 \times 13744}{1 + \frac{1}{1600} \times \left(\frac{6000}{62.5}\right)^2} = 1118224.8 \text{ N. Ans.}$$

The length of the column for which the above two formulae gives the same crushing load

Let  $L =$  Length of the column

Crushing load by Euler's formula =  $\frac{\pi^2 EI}{L^2}$

Crushing load by Rankine's formula =  $\frac{\sigma_c \cdot A}{1 + a \cdot \left(\frac{L}{k}\right)^2}$

Equating the crushing loads given by the above two formulae, we get

$$\frac{\pi^2 EI}{L^2} = \frac{\sigma_c \cdot A}{1 + a \cdot \left(\frac{L}{k}\right)^2}$$

Substituting the all known values except 'L', we get

$$\frac{\pi^2 \times 1.2 \times 10^5 \times 53689300}{L^2} = \frac{550 \times 13744}{1 + \frac{1}{1600} \times \left(\frac{L}{62.5}\right)^2}$$

$$\text{or } \frac{\pi^2 \times 1.2 \times 10^5 \times 53689300}{550 \times 13744} = \frac{L^2}{1 + \frac{L^2}{6250000}}$$

$$\text{or } 8411800 = \frac{L^2}{1 + \frac{L^2}{6250000}}$$

$$\text{or } 8411800 \left(1 + \frac{L^2}{6250000}\right) = L^2$$

$$\text{or } 8411800 + \frac{8411800}{6250000} L^2 = L^2 = L^2$$

$$\text{or } 8411800 + 1.346 L^2 = L^2 \text{ or } 1.346 L^2 - L^2 = -8411800$$

$$\text{or } 0.346 L^2 = -8411800 \text{ or } L = \sqrt{\frac{-8411800}{0.346}}$$

The above equation gives the imaginary value of length  $L$ .

Hence it is not possible to have the same length of the columns, which have the same crushing load for the two given formulae. **Ans.**

**Problem 19.18.** A hollow cast iron column 200 mm outside diameter and 150 mm inside diameter, 8 m long has both ends fixed. It is subjected to an axial compressive load. Taking a factor of safety as 6,  $\sigma_c = 560 \text{ N/mm}^2$ ,  $\alpha = \frac{1}{1600}$ , determine the safe Rankine load.

(AMIE, Summer 1990)

**Sol. Given :**

External dia.,  $D = 200 \text{ mm}$

Internal dia.,  $d = 150 \text{ mm}$

Length,  $l = 8 \text{ m} = 8000 \text{ mm}$

End conditions = Both the ends are fixed

Crushing stress,  $\sigma_c = 560 \text{ N/mm}^2$

Rankine's constant,  $\alpha = \frac{1}{1600}$

Safety factor = 6

$$\begin{aligned} \text{Area of cross-section, } A &= \frac{\pi}{4} (D^2 - d^2) = \frac{\pi}{4} (200^2 - 150^2) \\ &= \frac{\pi}{4} (40000 - 22500) = 13744 \text{ mm}^2 \end{aligned}$$

$$\begin{aligned} \text{Moment of inertia, } I &= \frac{\pi}{64} (D^4 - d^4) = \frac{\pi}{64} (200^4 - 150^4) \\ &= \frac{\pi}{64} (1600000000 - 506250000) = 53689000 \text{ mm}^4 \end{aligned}$$

$$\text{Least radius of gyration, } k = \sqrt{\frac{I}{A}} = \sqrt{\frac{53689000}{13744}} = 62.5 \text{ mm}$$

Let  $P =$  Crippling load by Rankine formula.

$$\text{Using equation (19.9), } P = \frac{\sigma_c \times A}{1 + \alpha \left(\frac{L_e}{k}\right)^2}$$

$$\text{where } L_e = \text{Effective length} = \frac{l}{2} = \frac{8000}{2} = 4000 \text{ mm}$$

$$\begin{aligned} P &= \frac{560 \times 13744}{1 + \frac{1}{1600} \times \left(\frac{4000}{62.5}\right)^2} \\ &= \frac{7696640}{1 + 2.56} = \frac{7696640}{3.56} = 2161977 \text{ N} = 2161.977 \text{ kN} \end{aligned}$$

$$\therefore \text{ Safe load} = \frac{\text{Crippling load}}{\text{Factor of safety}} = \frac{2161.977}{6} = 360.3295 \text{ kN. Ans.}$$

**Problem 19.19.** A hollow C.I. column whose outside diameter is 200 mm has a thickness of 20 mm. It is 4.5 m long and is fixed at both ends. Calculate the safe load by Rankine's formula using a factor of safety of 4. Calculate the slenderness ratio and the ratio of Euler's and

Rankine's critical loads. Take  $\sigma_c = 550 \text{ N/mm}^2$ ,  $\alpha = \frac{1}{1600}$  in Rankine's formula and  $E = 9.4 \times 10^4 \text{ N/mm}^2$ .

(AMIE, Winter 1979 ; Annamalai University, 1991)

**Sol. Given :**

Outside diameter,  $D = 200 \text{ mm}$

Thickness,  $t = 20 \text{ mm}$

$\therefore$  Inside diameter,  $d = D - 2 \times t = 200 - 2 \times 20 = 160 \text{ mm}$

$$\text{Area, } A = \frac{\pi}{4} (D^2 - d^2) = \frac{\pi}{4} (200^2 - 160^2) = 11310 \text{ mm}^2$$

$$\text{Moment of inertia, } I = \frac{\pi}{64} (D^4 - d^4) = \frac{\pi}{64} (200^4 - 160^4) = 46370000 \text{ mm}^4$$

And the least radius of gyration,

$$k = \sqrt{\frac{I}{A}} = \sqrt{\frac{46370000}{11310}} = 64 \text{ mm}$$

Length of column,  $l = 4.5 \text{ m} = 4500 \text{ mm}$

End condition = Both the ends are fixed

$$\therefore \text{ Effective length, } L_e = \frac{l}{2} = \frac{4500}{2} = 2250 \text{ mm}$$

Factor of safety = 4

Value of  $\sigma_c = 550 \text{ N/mm}^2$

$$\text{Value of } \alpha = \frac{1}{1600}$$

Value of  $E = 9.4 \times 10^4 \text{ N/mm}^2$ .

(i) Slenderness ratio

Using equation (19.8), we get

$$\text{Slenderness ratio} = \frac{l}{k} = \frac{4500}{64} = 70.30. \text{ Ans.}$$

(ii) Safe load by Rankine's formula

Let  $P =$  Crippling load by Rankine's formula

$$\text{Using equation (19.9), } P = \frac{\sigma_c \times A}{1 + \alpha \left(\frac{L_e}{k}\right)^2} = \frac{550 \times 11310}{1 + \frac{1}{1600} \left(\frac{2250}{64}\right)^2} = 351100 \text{ N}$$

$$\therefore \text{ Safe load} = \frac{\text{Crippling load}}{\text{Factor of safety}} = \frac{351100}{4} = 87775 \text{ N. Ans.}$$

(iii) Ratio of Euler's and Rankine's critical loads

Let  $P_E =$  Euler's critical load

Euler's critical load is given by equation (19.5)

$$P_E = \frac{\pi^2 EI}{L_e^2} = \frac{\pi^2 \times 9.4 \times 10^4 \times 46370000}{2250^2} = 849770 \text{ N}$$

$$\therefore \frac{\text{Euler's critical load}}{\text{Rankine's critical load}} = \frac{P_E}{P}$$

$$= \frac{849770}{351100}$$

$$= 2.42. \text{ Ans.}$$

$$(\because P = 351100 \text{ N})$$

**Problem 19.20.** A column is made up of two channel ISJC 200 and two 25 cm × 1 cm flange plate as shown in Fig. 19.12.

Determine by Rankine's formula the safe load, the column of 6 m length, with both ends fixed, can carry with a factor of safety 4. The properties of one channel are  $A = 17.77 \text{ cm}^2$ ,  $I_{XX} = 1,161.2 \text{ cm}^4$  and  $I_{YY} = 84.2 \text{ cm}^4$ . Distance of centroid from back of web = 1.97 cm. Take  $\sigma_c = 0.32 \text{ kN/mm}^2$  and Rankine's constant =  $1/7,500$ .

**Sol.** Given :

Length of the column,  $l = 6 \text{ m} = 600 \text{ mm}$

Factor of safety = 4

Yield stress,  $\sigma_c = 0.32 \text{ kN/mm}^2$

Rankine's constant,  $a = \frac{1}{7,500}$

Let  $P =$  Crippling load on the column.

From the geometry of figure, we find that area of column,

$$A = 2(17.77 + 25 \times 1) \\ = 85.54 \text{ cm}^2 = 8554 \text{ mm}^2$$

and moment of inertia of the column section about X-X axis,

$$I_{XX} = 2 \times 1,161.2 + 2 \left( \frac{25 \times 1^3}{12} + 25 \times 1 \times 10.5^2 \right) \text{ cm}^4 = 7,839.0 \text{ cm}^4$$

Similarly,

$$I_{YY} = 2 \left\{ \frac{1 \times 25^3}{12} + 8.42 + 17.77 \times (5 + 1.97)^2 \right\} \text{ cm}^4 = 4,499.0 \text{ cm}^4$$

Since  $I_{YY}$  is less than  $I_{XX}$ , therefore the column will tend to buckle in y-y direction. Thus we shall make the value of  $I$  as  $I_{YY} = 4,499 \text{ cm}^4$ . Moreover as the column is fixed at its both ends, therefore equivalent length of the column,

$$L_e = \frac{l}{2} = \frac{6000}{2} = 3000 \text{ mm}$$

$$I = 4499 \text{ cm}^4 = 4499 \times 10^4 \text{ mm}^4$$

and

We know that the least radius of gyration,

$$k = \sqrt{\frac{I}{A}} = \sqrt{\frac{4499 \times 10^4}{8554}} = 72.5 \text{ mm}$$

Using the relation,  $P = \frac{\sigma_c \cdot A}{1 + a \left( \frac{L_e}{k} \right)^2}$  with usual notations

$$= \frac{0.32 \times 8554}{1 + \frac{1}{7,500} \left( \frac{3000}{72.5} \right)^2} = 2228 \text{ kN}$$

We know that the safe load on the column

$$= \frac{P}{\text{Factor of safety}} = \frac{2228}{4} = 557 \text{ kN. Ans.}$$

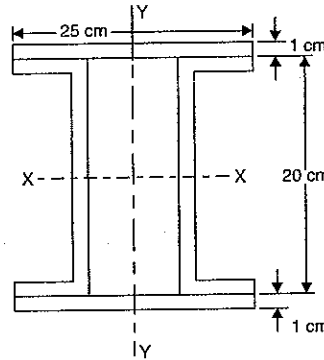

Fig. 19.12

### 19.12. STRAIGHT LINE FORMULA

The Euler's formula and Rankine's formula give only the approximate values of crippling load due to the following reasons :

1. The pin joints are not practically frictionless.
2. The end fixation is never perfectly rigid.
3. In case of Euler's formula, the effect of direct compression has been neglected.
4. The load is not exactly applied as desired.
5. The members are never perfectly straight and uniform in section.
6. The material of the members is not homogeneous and isotropic.

On account of this, the empirical straight line formula are commonly used in practical designing. They are of the form

$$P = \sigma_c \times A - n \left( \frac{L_e}{k} \right) \times A \quad \dots(19.10)$$

where  $P =$  Crippling load on the column,

$\sigma_c =$  Compressive yield stress,

$A =$  Area of cross-section of the column,  $\frac{L_e}{k} =$  Slenderness ratio, and

$n =$  A constant whose value depends upon the material of the column.

In equation (19.10), if  $P$  is plotted against  $\left( \frac{L_e}{k} \right)$ , we will get a straight line and hence the equation (19.10) represents a straight line formula. The equation (19.10) can also be written as

$$\frac{P}{A} = \sigma_c - n \cdot \left( \frac{L_e}{k} \right)$$

where  $\frac{P}{A}$  represents the stress corresponding to load  $A$ .

### 19.13. JOHNSON'S PARABOLIC FORMULA

The critical load according to Prof. Johnson, is given by

$$P = \sigma_c \cdot A - r \left( \frac{L_e}{k} \right) \times A \quad \dots(19.11)$$

where  $\sigma_c =$  Compressive yield stress,

$r =$  A constant whose value depends upon the material of the column and is taken as

$$= \frac{\sigma_c}{4\pi^2 E^2}, \text{ where } E = \text{Young's modulus}$$

$\frac{L_e}{k} =$  Slenderness ratio

$A =$  Cross-sectional area of column.

In equation (19.11), if  $P$  is plotted against  $\left( \frac{L_e}{k} \right)$ , we will get a parabolic curve and hence the formula represented by equation (19.11) is known as a parabolic formula.

### 19.14. FACTOR OF SAFETY

The ratio of the critical load to the safe load is known as factor of safety. The values of the safety factors usually used for different materials are given below :

Column material	Factor of safety
Mild steel	3
Wrought iron	3
Cast iron	5
Timber	6

### 19.15. FORMULA BY INDIAN STANDARD CODE (I.S. CODE) FOR MILD STEEL

The direct stress in compression on the gross area of the section of an axially loaded compression member shall not exceed the values of  $\sigma_c$ , calculated as follows and given in Table 19.3.

$$\sigma_c = \sigma_c' = \frac{\frac{\sigma_y}{m}}{1 + 0.20 \sec \left[ \frac{L_e}{k} \sqrt{\frac{m p_c'}{4E}} \right]} \quad \left( \text{for } \frac{L_e}{k} = 0 \text{ to } 160 \right)$$

$$\sigma_c = \sigma_c' \left( 1.2 - \frac{L_e}{800k} \right) \quad \left( \text{for } \frac{L_e}{k} = 160 \text{ and above} \right)$$

where  $\sigma_c$  = Allowable axial compression stress obtained from Table 19.3

$\sigma_c'$  = A value obtained from the above secant formula

$\sigma_y$  = The guaranteed minimum yield stress taken as 260 N/mm<sup>2</sup> for mild steel

$m$  = Factor of safety taken as 1.68

$\frac{L_e}{k}$  = Slenderness ratio

$E$  = Modulus of elasticity =  $2.047 \times 10^5$  N/mm<sup>2</sup>.

Safe stresses ( $\sigma_c$ ) in axial compression according to I.S. code for mild steel column is given in Table 19.3 for various values of slenderness ratio.

TABLE 19.3

Slenderness, ratio = $\frac{L_e}{k}$	Safe stress, $\sigma_c$ (N/mm <sup>2</sup> )	Slenderness ratio = $\frac{L_e}{k}$	Safe stress, $\sigma_c$ (N/mm <sup>2</sup> )
0	1.25	150	47.4
10	124.6	160	42.3
20	123.9	170	37.3
30	122.4	180	33.6
40	120.3	190	30.0
50	117.2	200	27.0
60	113.0	210	24.3
70	107.5	220	21.9

80	100.7	230	19.9
90	92.8	240	18.1
100	84.0	250	16.6
110	75.3	300	19.9
120	67.1	350	7.6
130	59.7		
140	53.1		

**Problem 19.21.** Determine the safe load by I.S. code for a hollow cylindrical mild steel tube of 4.0 cm external diameter and 3 cm internal diameter when the tube is used as a column of length 2.5 m long with both ends hinged.

**Sol. Given :**

External diameter,  $D = 4$  cm

Internal diameter,  $d = 3$  cm

$$\therefore \text{Area, } A = \frac{\pi}{4} [4^2 - 3^2] = 1.75\pi \text{ cm}^2 = 175\pi \text{ mm}^2$$

$$\text{Moment of inertia, } I = \frac{\pi}{64} [4^4 - 3^4] = 2.7343\pi \text{ cm}^4 = 27343\pi \text{ mm}^4$$

Length of column,  $l = 2.5$  m = 2500 mm

End conditions = Both ends hinged

$\therefore$  Effective length,  $L_e = l = 2500$  mm

To determine the safe load by I.S. code, first find the value of slenderness ratio. Then corresponding to the slenderness ratio, obtain the safe compressive stress (i.e., value of  $\sigma_c$ ) from the Table 19.3. Safe load will be equal to the product of  $\sigma_c$  and area  $A$ .

$$\text{Now slenderness ratio} = \frac{L_e}{k}$$

$$\text{where } k = \text{Least radius of gyration} = \sqrt{\frac{I}{A}} = \sqrt{\frac{27343}{175\pi}} = 15.62$$

$$\therefore \text{Slenderness ratio} = \frac{2500}{15.62} = 160.$$

From Table 19.3 corresponding to slenderness ratio of 160, the allowable compressive stress is 42.3 N/mm<sup>2</sup>.

$$\therefore \sigma_c = 42.3 \text{ N/mm}^2$$

$$\therefore \text{Safe load for the column} = \sigma_c \times A$$

$$= 42.3 \times 175\pi \text{ N} = 23255.6 \text{ N. Ans.}$$

### 19.16. COLUMNS WITH ECCENTRIC LOAD

Fig. 19.13 (a) shows a column  $AB$  of length ' $l$ ' fixed at end  $A$  and free at end  $B$ . The column is subjected to a load  $P$  which is eccentric by an amount of ' $e$ '. The free end will sway sideways by an amount ' $a$ ' and the column will deflect as shown in Fig. 19.13 (b).

Here  $a$  = deflection at free end  $B$

$e$  = Eccentricity

$A$  = Area of cross-section of column

Consider any section at a distance  $x$  from the fixed end  $A$ .



Let  $y$  = deflection at the section then moment at the section =  $P(a + e - y)$   
 (+ve sign is taken due to sign convention given in Art. 19.4.1.)

But moment is also =  $EI \frac{d^2y}{dx^2}$

$$\therefore EI \frac{d^2y}{dx^2} = P(a + e - y) = P(a + e) - P \times y$$

or  $EI \frac{d^2y}{dx^2} + P \times y = P(a + e)$

or  $\frac{d^2y}{dx^2} + \frac{P}{EI} \times y = \frac{P}{EI} (a + e)$

The above equation can be written as

$$\frac{d^2y}{dx^2} + \alpha^2 y = \alpha^2 (a + e)$$

where  $\alpha^2 = \frac{P}{EI}$  or  $\alpha = \sqrt{\frac{P}{EI}}$

The complete solution of the above equation is,

$$\begin{aligned} y &= C_1 \cos(\alpha \cdot x) + C_2 \sin(\alpha \cdot x) + (a + e) \\ &= C_1 \cos\left(\sqrt{\frac{P}{EI}} \times x\right) + C_2 \sin\left(\sqrt{\frac{P}{EI}} \times x\right) + (a + e) \\ &= C_1 \cos\left(x \times \sqrt{\frac{P}{EI}}\right) + C_2 \sin\left(x \times \sqrt{\frac{P}{EI}}\right) + (a + e) \end{aligned} \quad \dots(i)$$

and slope,  $\frac{dy}{dx} = -C_1 \left[\sin\left(x \times \sqrt{\frac{P}{EI}}\right) \times \sqrt{\frac{P}{EI}}\right] + C_2 \left[\cos\left(x \times \sqrt{\frac{P}{EI}}\right) \times \sqrt{\frac{P}{EI}}\right] + 0 \quad \dots(ii)$

( $\because a + e$  is constant, Hence differential is zero)

In equations (i) and (ii)  $C_1$  and  $C_2$  are constant of integration. Their values are obtained from boundary conditions.

(i) At A,  $x = 0, y = 0$  and also  $\frac{dy}{dx} = 0$  ( $\because A$  is a fixed end)

From equation (i) where  $x = 0$  and  $y = 0$ , we get

$$0 = C_1 + a + e \quad \therefore C_1 = -(a + e)$$

From equation (ii) where  $x = 0$  and  $\frac{dy}{dx} = 0$ , we get

$$0 = C_2 \times \sqrt{\frac{P}{EI}} \quad \therefore C_2 = 0 \quad \left(\because \frac{P}{EI} \text{ can not be zero}\right)$$

Substituting the values of  $C_1$  and  $C_2$  in equation (i), we get

$$y = -(a + e) \cos\left(x \times \sqrt{\frac{P}{EI}}\right) + (a + e) \quad \dots(iii)$$

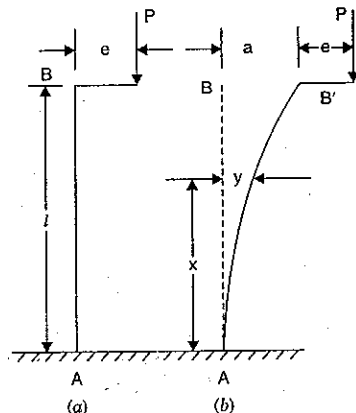

Fig. 19.13

(ii) at  $x = l, y = a$ , hence equation (iii) becomes as

$$a = -(a + e) \cos\left(l \times \sqrt{\frac{P}{EI}}\right) + (a + e)$$

or  $(a + e) \cos\left(l \times \sqrt{\frac{P}{EI}}\right) = a + e - a = e$

$$\therefore a + e = \frac{e}{\cos\left(l \times \sqrt{\frac{P}{EI}}\right)} = e \sec\left(l \times \sqrt{\frac{P}{EI}}\right) \quad \dots(iv)$$

**Maximum stress**

Let us find the maximum compressive stress for the column section. Due to eccentricity, there will be bending stress and also direct stress.

$$\therefore \sigma_{max} = \sigma_0 + \sigma_b \text{ where } \sigma_0 = \text{direct stress} = \frac{P}{A}$$

$$\sigma_b = \text{Max. bending stress.}$$

The maximum bending stress will be at the section where bending moment is maximum. Bending moment is maximum at the fixed end A.

$$\therefore \text{Max B.M. at A, } M = P \times (a + e)$$

$$= P \times e \sec\left(l \times \sqrt{\frac{P}{EI}}\right) \quad \left[\because a + e = e \sec\left(l \times \sqrt{\frac{P}{EI}}\right) \text{ from equation (iv)}\right]$$

Using  $\frac{M}{I} = \frac{\sigma_b}{y}$  or  $\sigma_b = \frac{M}{I} \times y = \frac{M}{\left(\frac{I}{y}\right)}$

$$= \frac{M}{Z} \text{ where } Z = \frac{I}{y} = \text{Section modulus}$$

$$= \frac{P \times e \sec\left(l \times \sqrt{\frac{P}{EI}}\right)}{Z} \quad \left[\because M = P \times e \sec\left(l \times \sqrt{\frac{P}{EI}}\right)\right]$$

Hence maximum compressive stress becomes as

$$\therefore \sigma_{max} = \sigma_0 + \sigma_b = \frac{P}{A} + \frac{P \times e \sec\left(l \times \sqrt{\frac{P}{EI}}\right)}{Z} \quad \dots(19.12)$$

The equation (19.12) is used for a column whose one end is fixed, other end is free and load is eccentric to the column. In this equation,  $l$  is the actual length of the column. The relation between actual length and effective length for a column whose one end is fixed and other end is free is given by

$$L_e = 2l \text{ or } l = \frac{L_e}{2}$$

Substituting the value of  $l$  in equation (19.12), we get a general formula which can be used for any end condition. Hence general formula is

$$\sigma_{max} = \frac{P}{A} + \frac{P \times e \times \sec\left(\frac{L_e}{2} \times \sqrt{\frac{P}{EI}}\right)}{Z} \quad \dots(19.13)$$

**Problem 19.22.** A column of circular section is subjected to a load of 120 kN. The load is parallel to the axis but eccentric by an amount of 2.5 mm. The external and internal diameters of columns are 60 mm and 50 mm respectively. If both the ends of the column are hinged and column is 2.1 m long, then determine the maximum stress in the column. Take  $E = 200 \text{ GN/m}^2$ .

**Sol.** Given :

$$\text{Load, } P = 120 \text{ kN} = 120 \times 10^3 \text{ N}$$

$$\text{Eccentricity, } e = 2.5 \text{ mm} = 2.5 \times 10^{-3} \text{ m}$$

$$D = 60 \text{ mm} = 0.06 \text{ m, } d = 50 \text{ mm} = 0.05 \text{ m, } l = 2.1 \text{ m}$$

$$\text{Both ends are hinged, } L_e = l = 2.1 \text{ m}$$

$$\text{Value of } E = 200 \text{ GN/m}^2 = 200 \times 10^9 \text{ N/m}^2$$

The maximum stress is given by equation (19.13) as

$$\sigma_{max} = \frac{P}{A} + \frac{P \times e \times \sec\left(\frac{L_e}{2} \times \sqrt{\frac{P}{EI}}\right)}{Z} \quad \dots(i)$$

where  $A =$  Area of section

$$= \frac{\pi}{4} [D^2 - d^2] = \frac{\pi}{4} [0.06^2 - 0.05^2]$$

$$= \frac{\pi}{4} \times 0.0011 = 8.639 \times 10^{-4} \text{ m}^2$$

$$I = \text{Moment of inertia} = \frac{\pi}{64} (D^4 - d^4)$$

$$= \frac{\pi}{64} (0.06^4 - 0.05^4) \text{ mm}^4$$

$$= \frac{\pi}{64} (1.296 \times 10^{-5} - 0.625 \times 10^{-5}) = 0.0329 \times 10^{-5}$$

$Z =$  Section modulus

$$= \frac{I}{y} = \frac{\pi [D^4 - d^4]}{64 \left(\frac{D}{2}\right)} = \frac{\pi [0.06^4 - 0.05^4]}{0.03}$$

$$= \frac{\pi (1.296 \times 10^{-5} - 0.625 \times 10^{-5})}{64 \times 0.03}$$

$$= 1.0975 \times 10^{-5} \text{ m}^3$$

$$\sec\left(\frac{L_e}{2} \times \sqrt{\frac{P}{EI}}\right) = \sec\left(\frac{2.1}{2} \times \sqrt{\frac{120 \times 10^3}{200 \times 10^9 \times 0.0329 \times 10^{-5}}}\right)$$

$$= \sec(1.4179 \text{ radians}) \text{ (Here 1.4179 is in radians)}$$

$$= 1.4179 \times \frac{180}{\pi} = 81.239$$

$$= \sec(81.239) = 6.566$$

Substituting these values in equation (i) above, we get

$$\sigma_{max} = \frac{120 \times 10^3}{8.639 \times 10^{-4}} + \frac{(120 \times 10^3) \times (2.5 \times 10^{-3}) \times 6.566}{1.0975 \times 10^{-5}}$$

$$= 138.9 \times 10^6 + 179.48 \times 10^6 \text{ N/m}^2$$

$$= 318.38 \times 10^6 \text{ N/m}^2 \text{ or } 318.38 \text{ N/mm}^2 \text{ Ans.}$$

**Problem 19.23.** If the given column of problem 19.22 is subjected to an eccentric load of 100 kN and maximum permissible stress is limited to  $320 \text{ MN/m}^2$ , then determine the maximum eccentricity of the load.

**Sol.** Given :

Data from problem 19.23

$$D = 60 \text{ mm} = 0.06 \text{ m, } d = 50 \text{ mm} = 0.05 \text{ m, } l = 2.1 \text{ m, } L_e = l = 2.1 \text{ m,}$$

$$E = 200 \text{ GN/m}^2 = 200 \times 10^9 \text{ N/m}^2, I = 0.0329 \times 10^{-5} \text{ m}^4,$$

$$Z = 1.0975 \times 10^{-5} \text{ m}^3, A = 8.639 \times 10^{-4} \text{ m}^2$$

$$\text{Eccentric load, } P = 100 \text{ kN} = 100 \times 10^3 \text{ N}$$

$$\text{Max. stress, } \sigma_{max} = 320 \text{ MN/m}^2 = 320 \times 10^6 \text{ N/m}^2$$

Let  $e =$  Maximum eccentricity

Using equation (19.13), we get

$$\sigma_{max} = \frac{P}{A} + \frac{P \times e \times \sec\left(\frac{L_e}{2} \times \sqrt{\frac{P}{EI}}\right)}{Z} \quad \dots(i)$$

Let us first find the value of  $\sec\left(\frac{L_e}{2} \times \sqrt{\frac{P}{EI}}\right)$ .

$$\sec\left(\frac{L_e}{2} \times \sqrt{\frac{P}{EI}}\right) = \sec\left[\frac{2.1}{2} \times \sqrt{\frac{100 \times 10^3}{200 \times 10^9 \times 0.0329 \times 10^{-5}}}\right]$$

$$= \sec[1.294 \text{ rads}] = \sec\left(1.294 \times \frac{180^\circ}{\pi}\right)$$

$$= \sec(74.16^\circ) = 3.665$$

Substituting the known values in equation (i), we get

$$320 \times 10^6 = \frac{100 \times 10^3}{8.639 \times 10^{-4}} + \frac{(100 \times 10^3) \times e \times 3.665}{1.0975 \times 10^{-5}}$$

$$= 115.754 \times 10^6 + 33394 e \times 10^6$$

or

$$320 = 115.754 + 33394 e$$

or

$$e = \frac{320 - 115.754}{33394} \text{ m} = 6.116 \times 10^{-3} \text{ m} = 6.116 \text{ mm. Ans.}$$

### 19.17. COLUMNS WITH INITIAL CURVATURE

Fig. 19.14 shows a column AB of length  $l$  hinged at both of its ends. The column is having initial curvature and this position is shown by AC'B. Let  $P$  be the crippling load at which the column has just buckled (i.e., has just started bending). This position is shown by AC''B. The initial shape of the column may be assumed circular, parabolic or sinusoidal without making much difference to the final result. But the most common form is

$$y' = C \times \sin\left(\frac{\pi x}{l}\right)$$

where  $C =$  Maximum initial deflection.

$y' =$  Initial deflection at a distance  $x$  from end A.

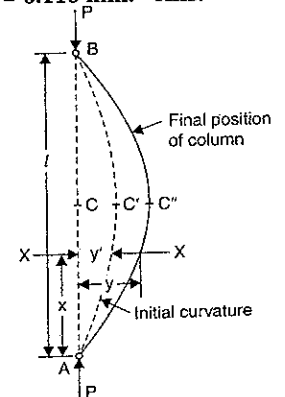

Fig. 19.14

$$\therefore \frac{dy'}{dx} = \frac{C\pi}{l} \cos\left(\frac{\pi x}{l}\right) \quad \dots(i)$$

and

$$\begin{aligned} \frac{d^2 y'}{dx^2} &= \frac{C\pi}{l} \left(-\frac{\pi}{l}\right) \sin\left(\frac{\pi x}{l}\right) \\ &= -\frac{C\pi^2}{l^2} \sin\left(\frac{\pi x}{l}\right). \end{aligned} \quad \dots(ii)$$

At the crippling load 'P', the final shape of column is shown by AC'B. Let y is the final deflection at a distance x from end A.

Change of deflection = (y - y')

Let change of deflection = y\*

Then y\* = (y - y')

This change of deflection is due to B.M equal to P × y

∴ B.M. at the section due to crippling load = - (P × y).

(- ve sign is due to sign convention given in Art. 19.4.1.)

But bending moment is also = EI  $\frac{d^2 y^*}{dx^2}$  or EI  $\frac{d^2 (y - y')}{dx^2}$  (∵ y\* = y - y')

Equating the two bending moments, we get

$$EI \frac{d^2 (y - y')}{dx^2} = -P \times y \quad \text{or} \quad \frac{d^2 y}{dx^2} - \frac{d^2 y'}{dx^2} = -\frac{P \times y}{EI}$$

or

$$\begin{aligned} \frac{d^2 y}{dx^2} + \frac{Py}{EI} &= \frac{d^2 y'}{dx^2} \\ &= -\frac{C\pi^2}{l^2} \sin\left(\frac{\pi x}{l}\right) \end{aligned}$$

$$\left[ \because \frac{d^2 y'}{dx^2} = -\frac{C\pi^2}{l^2} \sin\left(\frac{\pi x}{l}\right) \text{ from equation (ii)} \right] \dots(19.14)$$

Let the solution of the above differential equation is  $y = mC \sin\left(\frac{\pi x}{l}\right)$  ... (iii)

where m is a constant of integration.

The value of m will be obtained by finding the value of  $\frac{d^2 y}{dx^2}$  and substituting this value and value of y in equation (19.14)

Let us find the value of  $\frac{d^2 y}{dx^2}$  and substitute this value in equation (19.14)

Differentiating equation (iii) w.r.t. x, we get

$$\therefore \frac{dy}{dx} = mC \times \frac{\pi}{l} \cos\left(\frac{\pi x}{l}\right)$$

Again differentiating the above equation, we get

$$\frac{d^2 y}{dx^2} = -mC \times \frac{\pi^2}{l^2} \sin\left(\frac{\pi x}{l}\right)$$

Substituting the values of  $\frac{d^2 y}{dx^2}$  and y in equation (19.14), we get

$$-mC \times \frac{\pi^2}{l^2} \sin\left(\frac{\pi x}{l}\right) + \frac{P}{EI} \times mC \sin\left(\frac{\pi x}{l}\right) = -\frac{C\pi^2}{l^2} \sin\left(\frac{\pi x}{l}\right)$$

Concilling  $\sin\left(\frac{\pi x}{l}\right)$  to both sides, we get

$$-mC \times \frac{\pi^2}{l^2} + \frac{P}{EI} \times mC = -\frac{C\pi^2}{l^2}$$

Also concilling C to both sides, we get

$$-m \times \frac{\pi^2}{l^2} + \frac{P}{EI} \times m = -\frac{\pi^2}{l^2}$$

or

$$\frac{m\pi^2}{l^2} - \frac{P}{EI} m = \frac{\pi^2}{l^2} \quad \text{or} \quad m \left( \frac{\pi^2}{l^2} - \frac{P}{EI} \right) = \frac{\pi^2}{l^2}$$

or

$$m = \frac{\left(\frac{\pi^2}{l^2}\right)}{\left(\frac{\pi^2}{l^2} - \frac{P}{EI}\right)} = \left( \frac{1}{1 - \frac{P \times l^2}{EI \times \pi^2}} \right) \quad \dots(iv)$$

(Dividing numerator and denominator by  $\pi^2/l^2$ )

We know that  $P_E$  = Euler's load is given by

$$P_E = \frac{\pi^2 \times EI}{l^2}$$

Hence substituting the value of  $\frac{\pi^2 \times EI}{l^2}$  in equation (iv), we get

$$m = \frac{1}{1 - \frac{P}{P_E}} = \frac{P_E}{P_E - P}$$

The above equation gives the value of m in terms of Euler's load and axial load

Substituting the value of m in equation (iii), we get

$$y = \frac{P_E}{(P_E - P)} \times C \times \sin\left(\frac{\pi x}{l}\right) \quad \dots(19.15)$$

Equation (19.15) gives the final deflection at any distance x from end A.

### Maximum deflection

The deflection will be maximum at the mid-point where  $x = \frac{l}{2}$ . Let this maximum deflection is  $y_{max}$

∴ At  $x = \frac{l}{2}$ ,  $y = y_{max}$

Now the equation (19.15) becomes as

$$y_{max} = \frac{P_E}{(P_E - P)} \times C \times \sin\left(\frac{\pi \times l}{2}\right) \quad \left( \because y = y_{max}, x = \frac{l}{2} \right)$$

$$= \left( \frac{P_E}{P_E - P} \right) \times C \times \sin \frac{\pi}{2}$$

$$= \left( \frac{P_E}{P_E - P} \right) \times C \quad \left( \because \sin \frac{\pi}{2} = 1 \right)$$

**Maximum stress**

The maximum stress ( $\sigma_{max}$ ) is due to direct stress ( $\sigma_0$ ) and maximum bending stress

$$\sigma_{max} = \sigma_0 + \sigma_b \quad \dots(v)$$

The bending stress should be compressive. It will be maximum, where bending moment is maximum.

But  $B.M. = P \times y$ . Hence maximum  $B.M. = P \times y_{max}$  where  $y_{max} = \frac{(P_E)}{P_E - P} \times C$

$$\therefore \text{Maximum } B.M., M = P \times \frac{P_E}{(P_E - P)} \times C$$

$$\sigma_b = \frac{M}{Z} = \frac{P \times \left( \frac{P_E}{P_E - P} \right) \times C}{\left( \frac{Ak^2}{y_c} \right)} \quad \text{where } Z = \frac{I}{y_c} = \frac{Ak^2}{y_c}$$

where  $y_c$  = Distance from the neutral axis of the extreme layer in compression

Substituting the value of  $\sigma_b$  in equation (v), we get

$$\sigma_{max} = \sigma_0 + \frac{P \times \frac{P_E}{(P_E - P)} \times C}{\frac{Ak^2}{y_c}} = \sigma_0 + \left[ P \times \frac{P_E}{(P_E - P)} \times C \right] \times \frac{y_c}{Ak^2}$$

$$= \sigma_0 + \frac{P}{A} \times \left( \frac{P_E}{P_E - P} \right) \times \frac{C \times y_c}{k^2}$$

$$= \sigma_0 + \sigma_0 \left[ \left( \frac{P_E}{P_E - P} \right) \times \frac{C \times y_c}{k^2} \right] \quad \left[ \because \frac{P}{A} = \sigma_0 \right]$$

$$= \sigma_0 \left[ 1 + \left( \frac{P_E}{P_E - P} \right) \times \frac{C \times y_c}{k^2} \right]$$

$$\frac{\sigma_{max}}{\sigma_0} = 1 + \frac{P_E}{(P_E - P)} \times \frac{C \times y_c}{k^2}$$

$$\left( \frac{\sigma_{max}}{\sigma_0} - 1 \right) = \frac{P_E}{P_E - P} \times \frac{C \times y_c}{k^2}$$

$$= \left( \frac{\sigma_E}{\sigma_E - \sigma_0} \right) \times \frac{C \times y_c}{k^2} = \left( \frac{1}{1 - \frac{\sigma_0}{\sigma_E}} \right) \times \frac{C \times y_c}{k^2}$$

$$\left( \frac{\sigma_{max}}{\sigma_0} - 1 \right) \left( 1 - \frac{\sigma_0}{\sigma_E} \right) = \frac{C \times y_c}{k^2} \quad \dots(19.16)$$

The term  $\frac{P_E}{P_E - P}$  has been written in terms of stresses as

$$\frac{P_E}{P_E - P} = \frac{\frac{P_E}{A}}{\frac{P_E}{A} - \frac{P}{A}} = \frac{\sigma_E}{(\sigma_E - \sigma_0)} = \frac{1}{(1 - \sigma_0/\sigma_E)}$$

In equation (19.16),  $C$  is the initial maximum deflection and  $y_c$  is the distance of extreme layer in compression from neutral axis.

**Problem 19.24.** Determine the maximum stress developed in a circular steel strut which is subjected to an axial load of 140 kN. The outside and inside diameters of the strut are 200 mm and 140 mm respectively. It is 5 m long and has both of its end hinged. The strut is having initial curvature of sinusoidal form with initial maximum deflection of 8 mm. Take  $E = 205 \text{ GN/m}^2$ .

**Sol.** Given :

Axial load,  $P = 140 \text{ kN} = 140 \times 10^3 \text{ N}$ ,  $D = 200 \text{ mm} = 0.2 \text{ m}$ ,  $d = 140 \text{ mm} = 0.14 \text{ m}$ ,  $l = 5 \text{ m}$ , both ends are hinged, initial maximum deflection,  $C = 8 \text{ mm} = 0.008 \text{ m}$ ,  $E = 205 \text{ GN/m}^2 = 205 \times 10^9 \text{ N/m}^2$ .

Let  $\sigma_{max}$  = Maximum stress developed

$$\text{Now, } A = \frac{\pi}{4} (D^2 - d^2) = \frac{\pi}{4} (0.2^2 - 0.14^2) \text{ m}^2$$

$$= \frac{\pi}{4} (0.04 - 0.0196) = 0.016 \text{ m}^2$$

$$I = \frac{\pi}{64} (D^4 - d^4) = \frac{\pi}{64} (0.2^4 - 0.14^4) \text{ m}^4$$

$$= \frac{\pi}{64} (0.0016 - 0.000384) = 5.968 \times 10^{-5} \text{ m}^4$$

$$k^2 = \frac{I}{A} = \frac{5.968 \times 10^{-5}}{0.016} = 0.00373$$

Let us now find the values of  $\sigma_0$  (stress due to direct load),  $\sigma_E$  (stress due to Euler's load) and  $y_c$

$$\sigma_0 = \frac{P}{A} = \frac{140 \times 10^3}{0.016} = 8.75 \times 10^6 \text{ N/m}^2$$

$$\sigma_E = \frac{P_E}{A} \quad \text{where } P_E = \text{Euler's load}$$

$$= \frac{\pi^2 EI}{l^2} = \frac{\pi^2 \times 205 \times 10^9 \times 5.968 \times 10^{-5}}{5^2} = 4.83 \times 10^6 \text{ N}$$

$$= \frac{4.83 \times 10^6}{0.016} = 301.87 \times 10^6 \text{ N/m}^2$$

$y_c$  = distance of extreme layer in compression from neutral axis

$$= \frac{D}{2} = \frac{0.2}{2} = 0.1 \text{ m}$$

These values are substituted in equation (19.16)

Now using equation (19.16), we get

$$\left(\frac{\sigma_{max}}{\sigma_0} - 1\right) \left(1 - \frac{\sigma_0}{\sigma_E}\right) = \frac{C \times y_c}{k^2}$$

or 
$$\left(\frac{\sigma_{max}}{8.75 \times 10^6} - 1\right) \left(1 - \frac{8.75 \times 10^6}{301.87 \times 10^6}\right) = \frac{0.008 \times 0.1}{0.00373}$$

or 
$$\left(\frac{\sigma_{max}}{8.75 \times 10^6} - 1\right) (1 - 0.02898) = 0.21447$$

or 
$$\left(\frac{\sigma_{max}}{8.75 \times 10^6} - 1\right) = \frac{0.21447}{(1 - 0.02898)} = 0.22088$$

$$\sigma_{max} = (1 + 0.22088) \times 8.75 \times 10^6 = 10.683 \times 10^6 \text{ N/m}^2. \text{ Ans.}$$

**19.18. STRUT WITH LATERAL LOAD (OR BEAM COLUMNS)**

Columns carry axial compressive loads. If the columns are also subjected to transverse loads, then they are known as beam columns. The transverse load is generally uniformly distributed. But let us consider two cases when

- (i) Transverse load is a point load and acts at the centre
- (ii) Transverse load is uniformly distributed.

**19.18.1. Strut Subjected to Compressive Axial Load or Axial Thrust and a Transverse Point Load at the Centre. Both ends are Pinned.** Fig. 19.15 shows a strut AB of length  $l$  subjected to compressive axial load  $P$  and a transverse point load  $W$  at the centre. The strut is pinned at both of its ends. Consider any section at a distance  $x$  from the end A. Let 'y' is the deflection at this section. The bending moment at the section is given by,

$$M = -Py - \frac{W}{2}x \quad \dots(i)$$

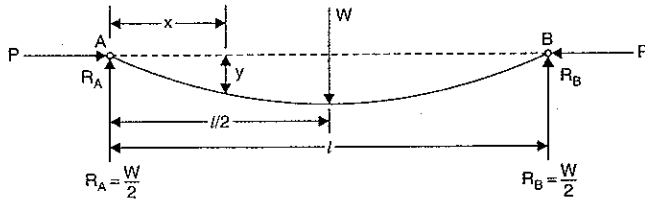

Fig. 19.15

B.M. is also given by,  $M = EI \frac{d^2y}{dx^2}$  ... (ii)

Equating the two B.M. given by equations (i) and (ii),

$$EI \frac{d^2y}{dx^2} = -Py - \frac{W}{2}x \quad \text{or} \quad \frac{d^2y}{dx^2} = -\frac{P}{EI} \times y - \frac{W}{2EI} \times x$$

or 
$$\frac{d^2y}{dx^2} + \frac{P}{EI} \times y = -\frac{W}{2EI} \times x.$$

The solution of the above differential equation is

$$y = C_1 \cos \left(x \times \sqrt{\frac{P}{EI}}\right) + C_2 \sin \left(x \times \sqrt{\frac{P}{EI}}\right) - \frac{W \times x}{2EI \times \frac{P}{EI}}$$

$$= C_1 \cos \left(x \times \sqrt{\frac{P}{EI}}\right) + C_2 \sin \left(x \times \sqrt{\frac{P}{EI}}\right) - \frac{W \times x}{2P} \quad \dots(iii)$$

The slope at any section is given by

$$\frac{dy}{dx} = -C_1 \times \sqrt{\frac{P}{EI}} \sin \left(x \times \sqrt{\frac{P}{EI}}\right) + C_2 \times \sqrt{\frac{P}{EI}} \cos \left(x \times \sqrt{\frac{P}{EI}}\right) - \frac{W}{2P} \quad \dots(iv)$$

The values of  $C_1$  and  $C_2$  are obtained from boundary conditions.

At  $x = 0, y = 0$ . Hence from equation (iii) we get

$$0 = C_1$$

At  $x = \frac{l}{2}, \frac{dy}{dx} = 0$ . Hence from equation (iv), we get

$$0 = -C_1 \times \sqrt{\frac{P}{EI}} \times \sin \left(\frac{l}{2} \times \sqrt{\frac{P}{EI}}\right) + C_2 \times \sqrt{\frac{P}{EI}} \cos \left(\frac{l}{2} \times \sqrt{\frac{P}{EI}}\right) - \frac{W}{2P}$$

$$= 0 + C_2 \times \sqrt{\frac{P}{EI}} \cos \left(\frac{l}{2} \times \sqrt{\frac{P}{EI}}\right) - \frac{W}{2P} \quad (\because C_1 = 0)$$

or

$$C_2 = \frac{W}{2P} \times \sqrt{\frac{EI}{P}} \times \frac{1}{\cos \left(\frac{l}{2} \times \sqrt{\frac{P}{EI}}\right)} = \frac{W}{2P} \times \sqrt{\frac{EI}{P}} \times \sec \left(\frac{l}{2} \times \sqrt{\frac{P}{EI}}\right)$$

Substituting the value of  $C_1$  and  $C_2$  is equation (iii), we get

$$y = 0 + \frac{W}{2P} + \sqrt{\frac{EI}{P}} \times \sec \left(\frac{l}{2} \times \sqrt{\frac{P}{EI}}\right) \sin \left(x \times \sqrt{\frac{P}{EI}}\right) - \frac{W \times x}{2P}$$

$$= \frac{W}{2P} \times \sqrt{\frac{EI}{P}} \times \sec \left(\frac{l}{2} \times \sqrt{\frac{P}{EI}}\right) \sin \left(x \times \sqrt{\frac{P}{EI}}\right) - \frac{W \times x}{2P} \quad \dots(v)$$

The above equation (v), gives the deflection at any section.

Let us now find maximum deflection, maximum bending moment and maximum stress induced.

**Maximum deflection ( $y_{max}$ ).** The deflection is maximum at the centre, where  $x = \frac{l}{2}$

Substituting  $x = \frac{l}{2}$  in equation (v), we get maximum deflection.

$$y_{max} = \frac{W}{2P} \times \sqrt{\frac{EI}{P}} \times \sec \left(\frac{l}{2} \times \sqrt{\frac{P}{EI}}\right) \sin \left(\frac{l}{2} \times \sqrt{\frac{P}{EI}}\right) - \frac{W}{2P} \times \frac{l}{2}$$

$$= \frac{W}{2P} \times \sqrt{\frac{EI}{P}} \times \tan \left(\frac{l}{2} \times \sqrt{\frac{P}{EI}}\right) - \frac{W \times l}{4P} \quad \dots(vi)$$

**Maximum bending moment.** The B.M. is given by equation (i) as

$$M = - \left( P \times y + \frac{W}{2} \times x \right)$$

The bending B.M. will be maximum at the centre where  $y = y_{max}$  and  $x = \frac{l}{2}$ . Substituting these values in the above equation, we get

$$\begin{aligned} M_{max} &= - \left( P \times y_{max} + \frac{W}{2} \times \frac{l}{2} \right) \\ &= - \left[ P \times \left\{ \frac{W}{2P} \times \sqrt{\frac{EI}{P}} \times \tan \left( \frac{l}{2} \times \sqrt{\frac{P}{EI}} \right) - \frac{W \times l}{4P} \right\} + \frac{W}{2} \times \frac{l}{2} \right] \\ &\quad \text{[Substitute } y_{max} \text{ here from equation (vi)]} \\ &= - \left[ \frac{W}{2} \times \sqrt{\frac{EI}{P}} \times \tan \left( \frac{l}{2} \times \sqrt{\frac{P}{EI}} \right) - \frac{W \times l}{4} + \frac{W \times l}{4} \right] \\ &= - \left[ \frac{W}{2} \times \sqrt{\frac{EI}{P}} \times \tan \left( \frac{l}{2} \times \sqrt{\frac{P}{EI}} \right) \right] \end{aligned}$$

The -ve sign is due to sign convention. Hence the magnitude of maximum B.M. is given

by

$$M_{max} \text{ (magnitude)} = \frac{W}{2} \times \sqrt{\frac{EI}{P}} \times \tan \left( \frac{l}{2} \times \sqrt{\frac{P}{EI}} \right) \quad \dots(19.17)$$

**Maximum stress ( $\sigma_{max}$ ).** Maximum stress induced is due to direct axial compressive load and due to maximum bending stress

$$\begin{aligned} \sigma_{max} &= \sigma_0 + \sigma_b \text{ where } \sigma_0 = \text{Stress due to direct axial compressive load} \\ &= \frac{P}{A} + \sigma_b \quad \sigma_b = \text{Stress due to bending.} \end{aligned}$$

The stress due to bending of strut is given by,

$$\begin{aligned} \frac{M}{I} &= \frac{\sigma_b}{y} \\ \sigma_b &= \frac{M \times y}{I} = \frac{M \times y_c}{Ak^2} \end{aligned}$$

where  $y_c$  = distance of the extreme layer in compression from neutral axis  
 $I = Ak^2$

$k$  = Radius of gyration

$M = M_{max}$

$$\text{Max. bending stress} = \frac{M_{max} \times y_c}{Ak^2}$$

$$= \left[ \frac{\frac{W}{2} \times \sqrt{\frac{EI}{P}} \times \tan \left( \frac{l}{2} \times \sqrt{\frac{P}{EI}} \right)}{AK^2} \right] \times y_c$$

$$\left[ \because \text{From equation 19.17, } M_{max} = \frac{W}{2} \times \sqrt{\frac{EI}{P}} \times \tan \left( \frac{l}{2} \times \sqrt{\frac{P}{EI}} \right) \right]$$

Hence maximum stress induced becomes as

$$\sigma_{max} = \frac{P}{A} + \left[ \frac{W}{2} \times \sqrt{\frac{EI}{P}} \times \tan \left( \frac{l}{2} \times \sqrt{\frac{P}{EI}} \right) \right] \times \frac{y_c}{Ak^2} \quad \dots(19.18)$$

**Problem 19.25.** Determine the maximum stress induced in a cylindrical steel strut of length 1.2 m and diameter 30 mm. The strut is hinged at both its ends and subjected to an axial thrust of 20 kN at its ends and a transverse point load of 1.8 kN at the centre. Take  $E = 208 \text{ GN/m}^2$ .

**Sol.** Given :

$l = 1.2 \text{ m}$  ;  $d = 30 \text{ mm} = 0.03 \text{ m}$  ; axial thrust,  $P = 20 \text{ kN} = 20 \times 10^3 \text{ N}$  ; transverse point load,  $W = 1.8 \text{ kN} = 1.8 \times 10^3 \text{ N}$  ;  $E = 208 \text{ GN/m}^2 = 208 \times 10^9 \text{ N/m}^2$

$$\text{Area, } A = \frac{\pi}{4} d^2 = \frac{\pi}{4} (0.03)^2 = 7.068 \times 10^{-4} \text{ m}^2$$

$$\text{M.O.I, } I = \frac{\pi}{64} d^4 = \frac{\pi}{64} (0.03)^4 = 3.976 \times 10^{-8} \text{ m}^4$$

Direct stress is due to axial thrust.

$$\therefore \sigma_0 = \frac{P}{A} = \frac{20 \times 10^3}{7.068 \times 10^{-4}} = 28.29 \times 10^6 \text{ N/m}^2 = 28.29 \text{ MN/m}^2$$

Maximum bending stress is given by

$$\sigma_b = \frac{M_{max} \times y_c}{I} \quad \dots(i)$$

Max. bending moment is given by equation (19.17), as

$$M_{max} = \frac{W}{2} \times \sqrt{\frac{EI}{P}} \times \tan \left( \frac{l}{2} \times \sqrt{\frac{P}{EI}} \right) \quad \dots(ii)$$

Let us find  $\sqrt{\frac{P}{EI}}$ .

$$\text{Now, } \sqrt{\frac{P}{EI}} = \sqrt{\frac{20 \times 10^3}{(208 \times 10^9) \times (3.976 \times 10^{-8})}} = \sqrt{2.4183} = 1.555$$

and

$$\frac{\sqrt{EI}}{P} = \frac{1}{1.555} = 0.643$$

$$\text{Also } \frac{l}{2} \times \sqrt{\frac{P}{EI}} = \frac{1.2}{2} \times 1.555 = 0.933 \text{ rad} = 0.933 \times \frac{180^\circ}{\pi} = 53.45^\circ$$

$$\therefore \tan \left( \frac{l}{2} \times \sqrt{\frac{P}{EI}} \right) = \tan (0.933 \text{ rad}) = \tan (53.45^\circ) = 1.349$$

Substituting known values in equation (ii), we get

$$M_{max} = \frac{1.8 \times 10^3}{2} \times 0.643 \times 1.349 = 780.66 \text{ Nm.}$$

Substituting the above value in equation (i), we get

$$\begin{aligned} \sigma_b &= \frac{780.66 \times y_c}{I} \\ &= \frac{780.66 \times 0.015}{3.976 \times 10^{-8}} \\ &\quad \left( \because y_c = \frac{d}{2} = \frac{30}{2} = 15 \text{ mm} = 0.015 \text{ m and } I = 3.976 \times 10^{-8} \text{ m}^4 \right) \\ &= 294.51 \times 10^6 \text{ N/m}^2 = 294.51 \text{ MN/m}^2 \end{aligned}$$

∴ Maximum stress induced is given by

$$\begin{aligned}\sigma_{max} &= \sigma_0 + \sigma_b \\ &= 28.29 \text{ MN/m}^2 + 294.51 \text{ MN/m}^2 = 322.8 \text{ MN/m}^2. \text{ Ans.}\end{aligned}$$

**19.18.2 Strut Subjected to Compressive Axial load or Axial thrust and a Transverse Uniformly Distributed load of Intensity  $w$  per unit length. Both ends are Pinned.** Fig. 19.16 shows a strut  $AB$  of length  $l$  subjected to axial thrust  $P$  at its ends and also a transverse uniformly distributed load of intensity  $w$ /unit length. The strut is pinned at both of its ends.

Consider any section at a distance ' $x$ ' from the end  $A$ . Let ' $y$ ' is deflection at this section. The bending moment at the section is given by,

$$\begin{aligned}M &= -P \times y + (w \times x) \times \frac{x}{2} - \frac{w \times l}{2} \times x \\ &= -P \times y + \frac{w \times x^2}{2} - \frac{w \times l \times x}{2} \quad \dots(i)\end{aligned}$$

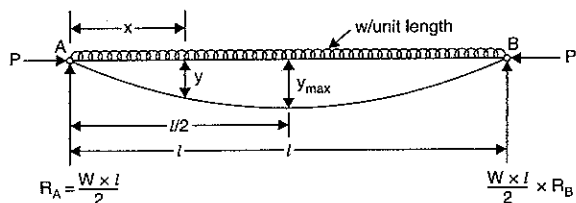

Fig. 19.16

Bending moment is also given by,

$$M = EI \frac{d^2 y}{dx^2} \quad \dots(ii)$$

Differentiating the equation (i), w.r.t. $x$ , we get

$$\begin{aligned}\frac{dM}{dx} &= -P \frac{dy}{dx} + \frac{w \times 2x}{2} - \frac{w \times l}{2} \\ &= -P \frac{dy}{dx} + w \times x - \frac{w \times l}{2}\end{aligned}$$

Differentiating the above equation again, we get

$$\frac{d^2 M}{dx^2} = -P \frac{d^2 y}{dx^2} + w \quad \dots(iii)$$

From equation (ii),  $\frac{d^2 y}{dx^2} = \frac{M}{EI}$ . Substituting this value in equation (iii), we get

$$\frac{d^2 M}{dx^2} = -P \times \frac{M}{EI} + w \quad \text{or} \quad \frac{d^2 M}{dx^2} + \frac{P}{EI} \times M = w$$

The above equation can be written as

$$\frac{d^2 M}{dx^2} + \alpha^2 M = w \quad \text{where } \alpha^2 = \frac{P}{EI} \quad \text{or} \quad \alpha = \sqrt{\frac{P}{EI}}$$

This equation is a differential equation in  $M$  and is more useful as the maximum bending moment can be obtained directly from this.

The solution of the above equation is

$$\begin{aligned}M &= C_1 \cos(\alpha \times x) + C_2 \sin(\alpha \times x) + \frac{w}{\alpha^2} \\ &= C_1 \cos\left(\sqrt{\frac{P}{EI}} \times x\right) + C_2 \sin\left(\sqrt{\frac{P}{EI}} \times x\right) + \frac{w \times EI}{P} \\ &= C_1 \cos\left(x \times \sqrt{\frac{P}{EI}}\right) + C_2 \sin\left(x \times \sqrt{\frac{P}{EI}}\right) + \frac{w \times EI}{P} \quad \dots(iv)\end{aligned}$$

Let us find  $\frac{dM}{dx}$  also from the above equation

$$\begin{aligned}\frac{dM}{dx} &= -C_1 \times \sqrt{\frac{P}{EI}} \sin\left(x \times \sqrt{\frac{P}{EI}}\right) + C_2 \times \sqrt{\frac{P}{EI}} \cos\left(x \times \sqrt{\frac{P}{EI}}\right) + 0 \\ &= -C_1 \sqrt{\frac{P}{EI}} \sin\left(x \times \sqrt{\frac{P}{EI}}\right) + C_2 \times \sqrt{\frac{P}{EI}} \cos\left(x \times \sqrt{\frac{P}{EI}}\right) \quad \dots(v)\end{aligned}$$

The values of  $C_1$  and  $C_2$  are obtained from boundary conditions. At  $x = 0$ ,  $M = 0$ , hence from equation (iv), we have

$$0 = C_1 + \frac{w \times EI}{P} \quad \therefore C_1 = -\frac{w \times EI}{P}$$

At  $x = \frac{l}{2}$ ,  $\frac{dM}{dx} = 0$  (as at the centre shear force  $= R_A - w \times \frac{l}{2} = \frac{w \times L}{2} - \frac{w \times L}{2} = 0$ ) hence from equation (v), we get

$$\begin{aligned}0 &= -C_1 \times \sqrt{\frac{P}{EI}} \sin\left(\frac{l}{2} \times \sqrt{\frac{P}{EI}}\right) + C_2 \times \sqrt{\frac{P}{EI}} \cos\left(\frac{l}{2} \times \sqrt{\frac{P}{EI}}\right) \\ &= -\left(-\frac{w \times EI}{P}\right) \times \sqrt{\frac{P}{EI}} \sin\left(\frac{l}{2} \times \sqrt{\frac{P}{EI}}\right) + C_2 \sqrt{\frac{P}{EI}} \cos\left(\frac{l}{2} \times \sqrt{\frac{P}{EI}}\right) \\ &\quad \left(\because c_1 = -\frac{w \times EI}{P}\right)\end{aligned}$$

$$\begin{aligned}\text{or} \quad 0 &= \frac{w \times EI}{P} \times \sin\left(\frac{l}{2} \times \sqrt{\frac{P}{EI}}\right) + C_2 \cos\left(\frac{l}{2} \times \sqrt{\frac{P}{EI}}\right) \\ &\quad \left(\text{Cancelling } \sqrt{\frac{P}{EI}} \text{ to both sides}\right)\end{aligned}$$

$$\text{or} \quad C_2 = -\frac{w \times EI}{P} \times \frac{\sin\left(\frac{l}{2} \times \sqrt{\frac{P}{EI}}\right)}{\cos\left(\frac{l}{2} \times \sqrt{\frac{P}{EI}}\right)} = -\frac{w \times EI}{P} \tan\left(\frac{l}{2} \times \sqrt{\frac{P}{EI}}\right)$$

Substituting the value of  $C_1$  and  $C_2$  in equation (iv), we get

$$\begin{aligned}M &= \left(-\frac{w \times EI}{P}\right) \times \cos\left(x \times \sqrt{\frac{P}{EI}}\right) + \left[-\frac{w \times EI}{P} \tan\left(\frac{l}{2} \times \sqrt{\frac{P}{EI}}\right)\right] \sin\left(x \times \sqrt{\frac{P}{EI}}\right) + \frac{w \times EI}{P} \\ &= \left(-\frac{w \times EI}{P}\right) \left[\cos\left(x \times \sqrt{\frac{P}{EI}}\right) + \tan\left(\frac{l}{2} \times \sqrt{\frac{P}{EI}}\right) \sin\left(x \times \sqrt{\frac{P}{EI}}\right) - 1\right].\end{aligned}$$

**Expression for maximum bending moment, maximum deflection and maximum stress**

**Maximum bending moment :**

The bending moment is maximum at  $x = \frac{l}{2}$ . Hence above equation becomes as

$$\begin{aligned} M_{\max} &= \left( \frac{-w \times EI}{P} \right) \left[ \cos \left( \frac{l}{2} \times \sqrt{\frac{P}{EI}} \right) + \tan \left( \frac{l}{2} \times \sqrt{\frac{P}{EI}} \right) \times \sin \left( \frac{l}{2} \times \sqrt{\frac{P}{EI}} \right) - 1 \right] \\ &= -\frac{w \times EI}{P} \left[ \cos \left( \frac{l}{2} \times \sqrt{\frac{P}{EI}} \right) + \frac{\sin \left( \frac{l}{2} \times \sqrt{\frac{P}{EI}} \right)}{\cos \left( \frac{l}{2} \times \sqrt{\frac{P}{EI}} \right)} \times \sin \left( \frac{l}{2} \times \sqrt{\frac{P}{EI}} \right) - 1 \right] \\ &= -\frac{w \times EI}{P} \left[ \frac{\cos^2 \left( \frac{l}{2} \times \sqrt{\frac{P}{EI}} \right) + \sin^2 \left( \frac{l}{2} \times \sqrt{\frac{P}{EI}} \right) - 1}{\cos \left( \frac{l}{2} \times \sqrt{\frac{P}{EI}} \right)} \right] \\ &= -\frac{w \times EI}{P} \left[ \frac{1}{\cos \left( \frac{l}{2} \times \sqrt{\frac{P}{EI}} \right)} - 1 \right] \\ &= -\frac{w \times EI}{P} \left[ \sec \left( \frac{l}{2} \times \sqrt{\frac{P}{EI}} \right) - 1 \right] \quad \dots(19.19) \end{aligned}$$

(- ve sign is due to sign convention)

**Maximum deflection :** The corresponding maximum deflection ( $y_{\max}$ ) is obtained from equation (i), in which  $M = \text{Max}$ ,  $y = y_{\max}$  and  $x = \frac{l}{2}$ . Hence equation (i) becomes as

$$\begin{aligned} M_{\max} &= -P \times y_{\max} + \frac{w}{2} \times \left( \frac{l}{2} \right)^2 - \frac{wl}{2} \times \frac{l}{2} \\ &= -P \times y_{\max} + \frac{w \times l^2}{8} - \frac{w \times l^2}{4} \\ &= -P \times y_{\max} - \frac{w \times l^2}{8} \\ &= - \left( P \times y_{\max} + \frac{wl^2}{8} \right) \end{aligned}$$

But from equation (19.19),

$$M_{\max} = -\frac{w \times EI}{P} \left[ \sec \left( \frac{l}{2} \times \sqrt{\frac{P}{EI}} \right) - 1 \right]$$

Equating the two values of  $M_{\max}$  we get

$$- \left( P \times y_{\max} + \frac{wl^2}{8} \right) = -\frac{w \times EI}{P} \left[ \sec \left( \frac{l}{2} \times \sqrt{\frac{P}{EI}} \right) - 1 \right]$$

$$\text{or} \quad P \times y_{\max} = \frac{w \times EI}{P} \left[ \sec \left( \frac{l}{2} \times \sqrt{\frac{P}{EI}} \right) - 1 \right] - \frac{wl^2}{8}$$

$$\text{or} \quad y_{\max} = \frac{w \times EI}{P^2} \left[ \sec \left( \frac{l}{2} \times \sqrt{\frac{P}{EI}} \right) - 1 \right] - \frac{wl^2}{8P} \quad \dots(19.20)$$

**Maximum stress :**

The maximum stress is then given by,

$$\begin{aligned} \sigma_{\max} &= \sigma_0 + \sigma_b \\ &= \frac{P}{A} + \frac{M_{\max}}{z} \quad \text{where} \quad \frac{M_{\max}}{z} = \frac{M_{\max}}{\left( \frac{I}{y_c} \right)} = \frac{M_{\max} \times y_c}{I} \end{aligned}$$

where  $y_c$  = distance of extreme layer in compression from N.A.

**Problem 19.26.** Determine the maximum stress induced in a horizontal strut of length 2.5 m and of rectangular cross-section 40 mm wide and 80 mm deep when it carries an axial thrust of 100 kN and a vertical load of 6 kN/m length. The strut is having pin joints at its ends. Take  $E = 208 \text{ GN/m}^2$ .

**Sol. Given :**

$l = 2.5 \text{ m}$ ;  $b = 40 \text{ mm} = 0.04 \text{ m}$ ;  $d = 80 \text{ mm} = 0.08 \text{ m}$ ; axial thrust,  $P = 100 \text{ kN} = 100 \times 1000 \text{ N}$ ; uniformly distributed load,  $w = 6 \text{ kN/m} = 6 \times 10^3 \text{ N/m}$ ;  $E = 208 \text{ GN/m}^2 = 208 \times 10^9 \text{ N/m}^2$  Area,  $A = b \times d = 0.04 \times 0.08 = 0.0032 \text{ m}^2$

$$I = \frac{bd^3}{12} = \frac{0.04 \times 0.08^3}{12} = 1.7066 \times 10^{-6} \text{ m}^4.$$

Let us now find the value of maximum bending moment (i.e.,  $M_{\max}$ ). Using equation (19.19), we get

$$M_{\max} = \frac{w \times EI}{P} \left[ \sec \left( \frac{l}{2} \times \sqrt{\frac{P}{EI}} \right) - 1 \right] \quad (\text{magnitude}) \quad (\text{neglect - ve sign})$$

$$\text{where} \quad \frac{P}{EI} = \frac{100 \times 1000}{208 \times 10^9 \times 1.7066 \times 10^{-6}} = 0.2817 \quad \text{and} \quad \frac{EI}{P} = \frac{1}{0.2817} = 3.55$$

$$\text{or} \quad \sqrt{\frac{P}{EI}} = \sqrt{0.2817} = 0.5307$$

$$\text{Also,} \quad \frac{l}{2} \times \sqrt{\frac{P}{EI}} = \frac{2.5}{2} \times 0.5307 = 0.6634 \text{ radians}$$

$$= \frac{0.6634 \times 180^\circ}{\pi} = 38^\circ$$

$$\therefore \quad \sec \left[ \frac{l}{2} \times \sqrt{\frac{P}{EI}} \right] = \sec 38^\circ = 1.269$$



$$M_{max} = w \times \frac{EI}{P} \left[ \sec \left( \frac{l}{2} \times \sqrt{\frac{P}{EI}} \right) - 1 \right] = (6 \times 10^3) \times 3.55 [1.269 - 1]$$

$$= 5729.70 \text{ Nm}$$

$$\text{Stress due to direct load, } \sigma_0 = \frac{P}{A} = \frac{100 \times 1000}{0.0032} \text{ N/m}^2 = 31.25 \times 10^6 \text{ N/m}^2$$

$$\text{Max. bending stress, } \sigma_b = \frac{M_{max} \times y_c}{I}$$

where  $y_c$  = distance of extreme layer in compression from neutral axis

$$= \frac{d}{2} = \frac{80}{2} = 40 \text{ mm} = 0.04 \text{ m}$$

$$\sigma_b = \frac{5729.7 \times 0.04}{1.7066 \times 10^{-6}} = 134.3 \times 10^6 \text{ N/m}^2$$

∴ Maximum stress induced is given by

$$\sigma_{max} = \sigma_0 + \sigma_b$$

$$\sigma_{max} = 31.25 \times 10^6 + 134.3 \times 10^6 \text{ N/m}^2$$

$$= 166.55 \times 10^6 \text{ N/m}^2 = 166.55 \text{ MN/m}^2. \text{ Ans.}$$

or

### HIGHLIGHTS

1. A vertical member of a structure, which is subjected to axial compressive load and is fixed at both of its ends, is known as a column.
2. Strut is a member of a structure which is not vertical or whose one or both of its ends are hinged or pin joined.
3. All short columns fail due to crushing whereas long columns fail due to buckling and crushing.
4. The load at which the column just buckles is known as buckling load or critical load or crippling load.
5. The crippling load for a column by Euler's formula for different end conditions is given by

$$P = \frac{\pi^2 EI}{l^2} \text{ when both ends are hinged}$$

$$= \frac{\pi^2 EI}{4l^2} \text{ when one end is fixed and other is free}$$

$$= \frac{4\pi^2 EI}{l^2} \text{ when both ends are fixed}$$

$$= \frac{2\pi^2 EI}{l^2} \text{ when one end is fixed and other is hinged}$$

where  $l$  = Actual length of column

$E$  = Young's modulus of the material of the column

$I$  = Least moment of inertia of the column.

6. The effective length of a given column with given end conditions is the length of an equivalent column of the same material and cross-section with hinged ends, and having the value of crippling load equal to that of the given column.

7. The crippling load for any type of end condition is given by

$$P = \frac{\pi^2 EI}{L_e^2}$$

where  $L_e$  = Effective length

=  $l$  when both ends hinged

=  $2l$  when one end is fixed and other is free

=  $\frac{l}{2}$  when both ends are fixed

=  $\frac{l}{\sqrt{2}}$  when one end fixed and other is hinged

where  $l$  = Actual length of the column.

8. Crippling load and crippling stress in terms of effective length and radius of gyration are given by

$$\text{Crippling loads, } P = \frac{\pi^2 E \cdot A}{\left(\frac{L_e}{k}\right)^2}$$

$$\text{and Crippling stress } = \frac{\pi^2 E}{\left(\frac{L_e}{k}\right)^2}$$

where  $L_e$  = Effective length and  $k$  = Least radius of gyration =  $\sqrt{\frac{I}{A}}$

where  $I$  = Least moment of Inertia.

9. Slenderness ratio is the ratio of the effective length of the column to the least radius of gyration. Mathematically,

$$\text{Slenderness ratio} = \frac{L_e}{k}$$

10. The crippling load by Rankine's formula is given by

$$P = \frac{\sigma_c \times A}{1 + a \left(\frac{L_e}{k}\right)^2}$$

where  $\sigma_c$  = Ultimate crushing stress

$A$  = Area of cross-section of column

$a$  = Rankine's constant

$L_e$  = Effective length

$k$  = Least radius of gyration.

11. The crippling load by straight line formula is given by

$$P = \sigma_c \cdot A - n \left(\frac{L_e}{k}\right) \cdot A$$

where  $\sigma_c$  = Compressive yield stress

$A$  = Area of cross-section of column

$\left(\frac{L_e}{k}\right)$  = Slenderness ratio and  $n$  = A constant.

12. Johnson's parabolic formula for crippling load is given by

$$P = \sigma_c \cdot A - r \left( \frac{L_c}{k} \right)^2 \cdot A$$

where  $\sigma_c$ ,  $A$  and  $\frac{L_c}{k}$  are compressive yield stress, area and slenderness ratio respectively and

$$r = A \text{ constant} = \frac{\sigma_c^2}{4\pi^2 E}$$

### EXERCISE 19

#### (A) Theoretical Questions

1. Explain the assumptions made in Euler's column theory. How far are the assumptions valid in practice? *(AMIE, Summer 1982)*
2. Define the terms : column, strut and crippling load.
3. Explain how the failure of a short and of a long column takes place?
4. What do you mean by end conditions of a column? What are the important end conditions for a column? Explain them.
5. What is 'equivalent length of a column'? How is the concept used in the column theory? *(AMIE, Winter 1982)*
6. What is 'equivalent length of a column'? Give the ratios of equivalent length and actual length of columns with various end conditions. *(AMIE, Summer 1985)*
7. Derive an expression for the Euler's crippling load for a long column with following end conditions.  
(a) Both ends are hinged (b) Both ends are fixed.
8. Explain how Rankine-Gordon formula is used to calculate the intensity of stress in short, intermediate and long columns. *(AMIE, Winter 1981)*
9. Prove that the crippling load by Euler's formula for a column having one end fixed and other end free is given by

$$P = \frac{\pi^2 EI}{4l^2}$$

where  $l$  = Actual length of the column,

$E$  = Young's modulus, and

$I$  = Least moment of inertia.

10. Find an expression for crippling load for a long column when one end of the column is fixed and other end is hinged.
11. Prove that crippling stress by Euler's formula is given by  $f_c = \frac{\pi^2 E}{\left( \frac{L_c}{k} \right)^2}$ .
12. Define slenderness ratio. State the limitations of Euler's formula.
13. How will you justify that Rankine's formula is applicable for all lengths of columns, ranging from short to long columns.
14. What is a Rankine's constant? What is the approximate value of Rankine's constant for cast iron column?
15. Deduce an expression for the Euler's crippling load of an 'ideal column' pin-jointed at each end. Explain the limitations, if any, in using the formula.

16. Derive the equation for the Euler's crippling load for a column with one end fixed and the other is free. *(Annamalai University, 1991)*
17. Derive expression for Euler's buckling load for a long column of length  $L$  with both ends fixed, from first principle. Mention the assumptions made in the derivation. *(Bangalore University, 1991)*

#### (B) Numerical Problems

1. A solid round bar 4 m long and 6 cm in diameter is used as a strut with both ends hinged. Determine the crippling load. Take  $E = 2 \times 10^5 \text{ N/mm}^2$ . *[Ans. 78.486 kN]*
2. For the problem 1, determine the crippling loads when the given strut is used with the following conditions :  
(i) One end is fixed and other end is free (ii) Both the ends are fixed and  
(iii) One end is fixed and other is hinged. *[Ans. (i) 19.621 kN (ii) 313.94 kN (iii) 156.96 kN]*
3. A column of timber section 10 cm  $\times$  15 cm is 5 m long both ends being fixed. If the Young's modulus for timber = 17.5 kN/mm<sup>2</sup>, determine :  
(i) Crippling load, and (ii) Safe load for the column if factor of safety = 3. *[Ans. (i) 45.4 kN and (ii) 115.1 kN]*
4. A hollow mild steel tube 5 m long, 4 cm internal diameter and 5 mm thick is used as a strut with both ends hinged. Find the crippling load and safe load taking factor of safety as 3. Taking  $E = 2 \times 10^5 \text{ N/mm}^2$ . *[Ans. 14.99 N and 4766 N]*
5. A solid circular bar 5 m long and 4 cm in diameter was found to extend 4.5 mm under a tensile load of 48 kN. The bar is used as a strut with both ends hinged. Determine the buckling load for the bar and also the safe load taking factor of safety as 3.0. *[Ans. 2105.5 N and 701.8 N]*
6. Calculate the safe compressive load on a hollow cast iron column (one end rigidly fixed and other hinged) of 10 cm external diameter, 7 cm internal diameter and 8 m in length. Use Euler's formula with a factor of safety of 4 and  $E = 95 \text{ kN/mm}^2$ . *[Ans. 27.3 kN]*
7. Determine Euler's crippling load for an I-section joist 30 cm  $\times$  15 cm  $\times$  2 cm and 5 m long which is used as a strut with both ends fixed. Take Young's modulus for the joist as  $2 \times 10^5 \text{ N/mm}^2$ . *[Ans. 3.6 MN]*
8. Determine the crippling load for a T-section of dimensions 12 cm  $\times$  12 cm  $\times$  2 cm and of length 6 cm when it is used as a strut with both of its ends hinged. Take  $E = 2 \times 10^5 \text{ N/mm}^2$ . *[Ans. 161.57 kN]*
9. Determine the ratio of buckling strengths of two columns one hollow and the other solid. Both are made of the same material and have the same length, cross-sectional area and end conditions. The internal diameter of hollow column is 2/3rd of its external diameter. *[Ans. 2.6 : 1]*
10. The external and internal diameter of a hollow cast iron column are 5 cm and 3 cm respectively. If the length of this column is 4 m and both of its ends are fixed, determine the crippling load using Rankine's formula. Take the value of  $f_c = 550 \text{ N/mm}^2$  and  $a = \frac{1}{1600}$  in Rankine's formula. *[Ans. 540.09 kN]*
11. A hollow cylindrical cast iron column is 6 m long with both ends fixed. Determine the minimum diameter of the column if it has to carry a safe load of 300 kN with a factor of safety of 4. Take the internal diameter as 0.7 times the external diameter. Take  $f_c = 550 \text{ N/mm}^2$  and  $a = \frac{1}{1600}$  in Rankine's formula. *[Ans.  $D = 9.53 \text{ cm}$ ,  $d = 6.67 \text{ cm}$ ]*
12. A 2.0 m long column has a circular cross-section of 6 cm diameter. One of the ends of the column is fixed in direction and position and other end is free. Taking factor of safety as 3, calculate the safe load using

(i) Rankine's formula take yield stress  $f_c = 550 \text{ N/mm}^2$  and  $\alpha = \frac{1}{1600}$  for pinned ends,

(ii) Euler's formula, Young's modulus for C.I. =  $1.3 \times 10^5 \text{ N/mm}^2$ .

[Ans. 11.4 kN and (ii) 170 kN]

13. A short length of tube, 5 cm internal diameter and 6 cm external diameter, failed in compression at a load of 250 kN. When 2.5 m length of the same tube was tested as a strut with fixed ends, the load at failure was 150 kN. Assuming that  $f_c$  in Rankine's formula is given by the first test, find the value of constant ' $\alpha$ ' in the same formula. What will be the crippling load of this tube if it is

used as a strut 3.2 m long with one end fixed and the other hinged. [Ans.  $\frac{1}{6148}$ , 78.5 kN]

14. Find the Euler crushing load for a hollow cylindrical cast iron column 15 cm external diameter and 25 mm thick if it is 6 m long and is hinged at both ends. Take  $E = 8 \times 10^4 \text{ N/mm}^2$ . Compare the load with the crushing load as given by the Rankine's formula, taking  $f_c = 550 \text{ N/mm}^2$  and

$\alpha = \frac{1}{1600}$ ; for what length of the column would these two formulae give the same crushing load?

[Ans. 665 kN, 260.77 kN, 507 cm]

15. A mild steel tube is 7.5 cm in diameter and 0.25 cm thick. A short length of this tube is tested in compression and is found to yield at  $500 \text{ N/mm}^2$ . The modulus of elasticity of the material of the tube is  $2 \times 10^5 \text{ N/mm}^2$ . A length of 2 m when tested as a strut with free ends failed with a load of 180 kN force. Assuming the failing stress in Rankine formula to be the yield stress of the material, find the value of Rankine's constant ' $\alpha$ '. Find also the crushing load as by the Euler's formula.

[Ans.  $\alpha = \frac{1}{8000}$  and  $P$  225 kN]

16. An alloy steel tube is 7.5 cm external diameter and 0.25 cm wall thickness. A very short length of this tube was tested in compression and found to yield at a load of 320 kN. A length of 2 meters when tested as a strut with hinged ends buckled at a load of 170 kN. Assuming the failing stress in Rankine formula to be the yield stress of the material, find the value of Rankine's constant ' $\alpha$ '.

[Ans.  $\alpha = \frac{1}{6930}$ ]

17. A 1.5 m long column has a circular cross-section of 0.5 cm diameter. One of the ends of the column is fixed in direction and position and the other end is free. Taking factor of safety as 3,

calculate the safe load using; (i) Rankine formula with  $f_c = 560 \text{ N/mm}^2$  and  $\alpha = \frac{1}{1600}$  for pinned ends and (ii) Euler's formula with  $E$  for C.I. =  $1.2 \times 10^5 \text{ N/mm}^2$ . (AMIE, Summer 1976)

[Ans. (i) 9.9 kN and (ii) 13.45 kN]

18. Determine the external diameter and internal diameter of a hollow circular cast iron column, which carries a load of 1000 kN. The length of the column is 6 metre. The internal diameter is to be one half that of outer diameter. Use Rankine's formula with  $f = 560 \text{ N/mm}^2$  and  $\alpha = \frac{1}{1600}$ . Take a factor of safety 4. One end is fixed and the other end is free.

[Ans.  $D = 35.4 \text{ cm}$ ,  $d = 17.7 \text{ cm}$ ]

# 20

## Riveted Joints

### 20.1. INTRODUCTION

Rivets which are having their greatest applications in boiler work, plate girder and roof truss etc., are used to connect together permanently two or more plates. In case of riveting, the holes are made in the plates which are to be connected and rivets are inserted into the holes of the plates. Due to the holes in the plate, the strength of the original plate (i.e., solid plate without any hole) is reduced.

### 20.2. TYPES OF RIVETED JOINTS

The riveted joints are mainly of the following two types :

1. Lap joints and 2. Butt joints

**20.2.1. Lap Joints.** In case of lap joint, the edges of the plates to be jointed together overlap each other as shown in Fig. 20.1. The lap joints are classified as :

1. Single riveted lap joint.
2. Double riveted lap joint.
3. Triple riveted lap joint etc.

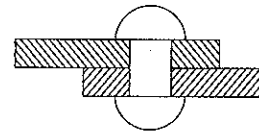

Fig. 20.1. Lap joint.

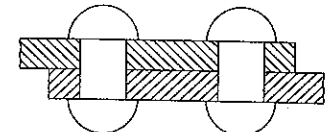

Fig. 20.2. Double riveted lap joint.

In case of single riveted lap joint, only one row of rivets is used for connecting two plates as shown in Fig. 20.1. But in case of double riveted lap joint, two rows of rivets are used for the connection as shown in Fig. 20.2. And in case of triple lap joints, three rows of rivets are used for connecting the two plates.

**20.2.2. Butt Joints.** In case of butt joints, the edges of the two plates to be joined together butt (i.e., touch) against each other and a cover plate is placed either on one side or on both the sides of the two main plates as shown in Fig. 20.3.

In case of a butt joint, atleast two rows of rivets one on each side of the joint, are required.

The butt joints are also classified as :

1. Single riveted butt joint,
2. Double riveted butt joint, and
3. Triple riveted butt joint.

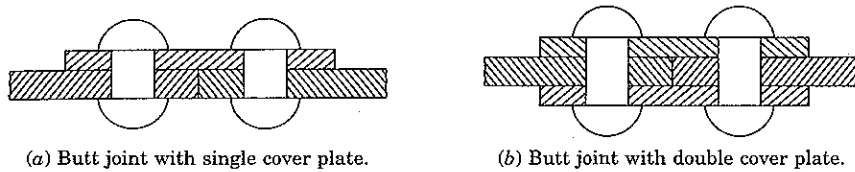

Fig. 20.3

In case of a single riveted butt joint, one row of rivets is used on each side of the joint. Hence in total there are two rows of rivets. In case of double riveted butt joint, two rows of rivets are used on each side of the joint and hence in total there are four rows of rivets in double riveted joint. In case of triple butt joints, three rows of rivets are used on each side of the joint.

In addition to the above, the following are also the types of the riveted joints :

1. Chain riveted joint,
2. Zig-zag riveted joint and
3. Diamond riveted joint.

**20.3. CHAIN RIVETED JOINT**

Fig. 20.4 shows a chain riveted joint, in which every rivet of a row is opposite to the other rivet of the other row.

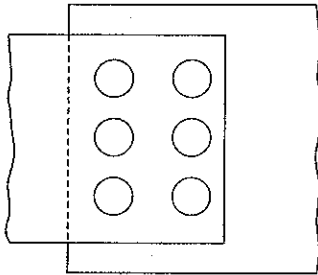

Fig. 20.4. Chain riveted joint.

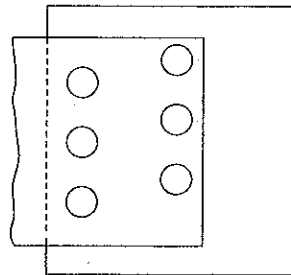

Fig. 20.5. Zig-zag riveted joint.

**20.4. ZIG-ZAG RIVETED JOINT**

Fig. 20.5 shows a zig-zag riveted joint, in which the spacing of the rivets is staggered in such a way, that every rivet is in the middle of the two rivets of the opposite row.

**20.5. DIAMOND RIVETED JOINT**

Fig. 20.6 shows a diamond riveted joint, in which the number of rivets decreases as we proceed from innermost row to the outermost row. Diamond riveted joint is only used in butt joints.

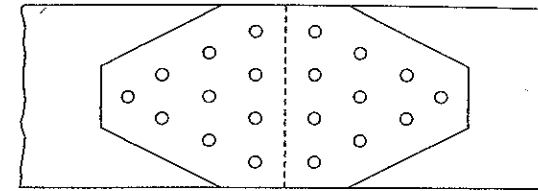

Fig. 20.6. Diamond riveted joint.

**Problem 20.1.** Draw neat sketches (plan and elevation) of the following riveted joints :

- (i) Single riveted lap joint,
- (ii) Double riveted lap joint having chain riveting,
- (iii) Double riveted lap joint having zig-zag riveting.

**Sol.** (i) Single riveted lap joint with its plan and elevation is shown in Fig. 20.7. In case of lap joint, the edges of the two plates to be joined together overlap each other. For a single riveted joint, there should be only one row of rivets as shown the plan of Fig. 20.7. The distance from the axis of the rivet to the edge of the plate should be at least  $= 1.5 D$ , where  $D$  is the diameter of the rivet. The distance between two adjacent rivets in a row is called the pitch and it is denoted by  $p$ .

The plan and elevation of a single riveted lap joint is shown in Fig. 20.7.

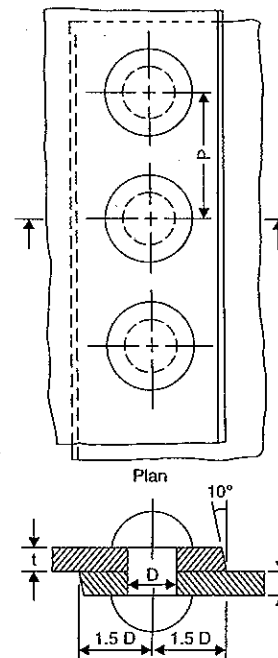

Fig. 20.7. Single riveted lap joint.

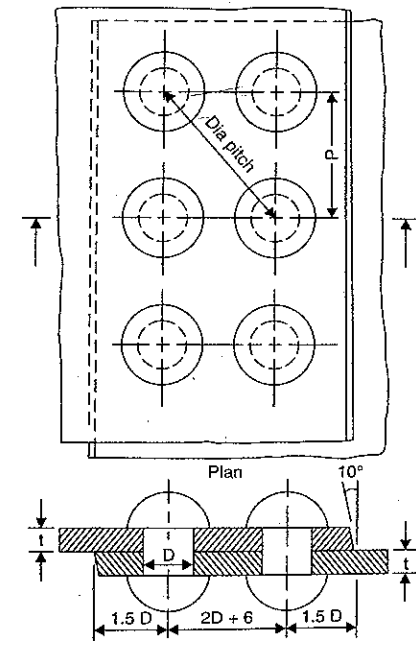

Fig. 20.8. Double-riveted lap joint—chain riveting.

(ii) *Double riveted lap joint having chain riveting.* This is shown in Fig. 20.8. In case of double riveted lap joint, there should be two rows of rivets as shown in plan. For a chain riveted joint, every rivet of a row should be opposite to the other rivet of the other row as shown in Fig. 20.8. The distance between the two rows of the rivets should be at least  $= 2D + 6$ , where  $D$  is the diameter of the rivet.

The plan and elevation of the double riveted lap joint having chain riveting is shown in Fig. 20.8.

(iii) *Double riveted lap joint having zig-zag riveting.* This is shown in Fig. 20.9. There are two rows of rivets as shown in plan. For a zig-zag riveted joint, the spacing of the rivets is staggered in such a way that every rivet is in the middle of the two rivets of the opposite row as shown in Fig. 20.9. The distance between the two rows of rivets should be at least  $= 2D$ , where  $D$  is the diameter of the rivet. The plan and elevation of the double riveted lap joint having zig-zag riveting is shown in Fig. 20.9.

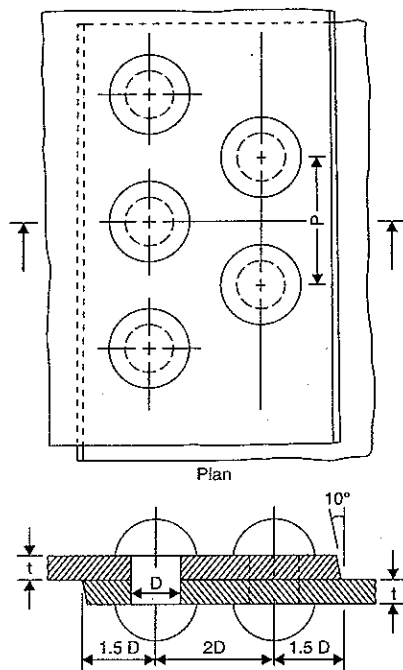

Fig. 20.9. Double-riveted lap joint—Zig-zag riveting.

**Problem 20.2.** Draw neat sketches (Plan and Elevation) of the following riveted joints :

- (i) Single riveted butt joint with a single cover plate
- (ii) Single riveted butt joint with double cover plate
- (iii) Double riveted butt joint with a single cover plate.

(AMIE, Summer 1985 and Winter 1981)

**Sol. (i) Single riveted butt joint with a single cover plate.** In case of a butt joint, the edges of the two plates to be joined together butt (*i.e.*, touch) against each other and a cover plate is placed on one side of the two plates. Rivets are passed through the main plates and cover plates. For a single riveted butt joints, one row of rivets is used on each side of the joint. Hence in total, there will be two rows of rivets as shown in Fig. 20.10. For a single cover plate, the thickness of the cover plate is taken as equal to  $t$  or  $1.125t$ , where  $t$  is the thickness of the main plate to be joined by butt joint. The distance between the two rows of rivets should be equal to  $3D$  where  $D$  is the diameter of the rivet. The plan and elevation of the single riveted butt joint with single cover plate is shown in Fig. 20.10.

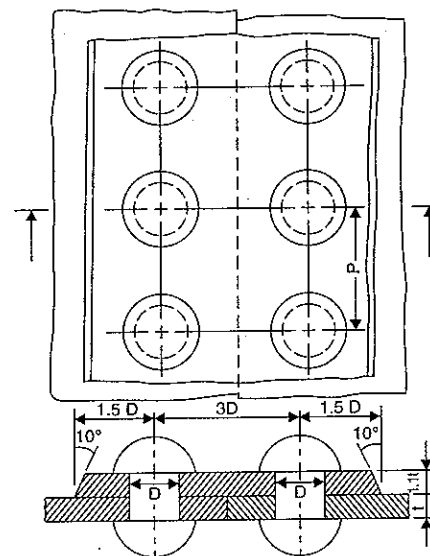

Fig. 20.10. Single riveted butt joint with a single cover plate.

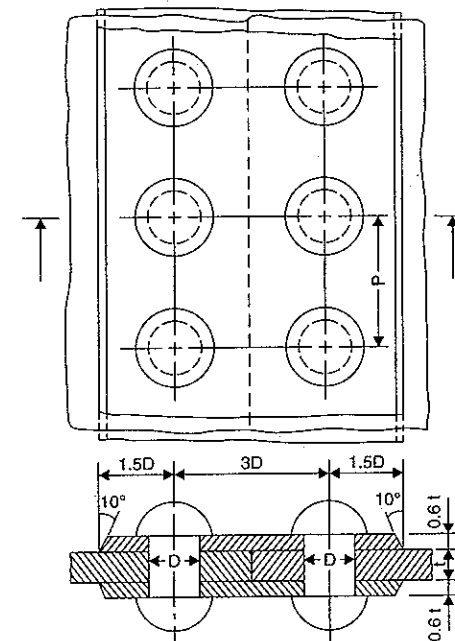

Fig. 20.11. Single riveted butt joint with double cover.

(ii) *Single riveted butt joint with double cover plates.* In case of single riveted butt joint, there will be two rows of rivets as shown in Fig. 20.11. One row of rivets is used on each side of the joints. There will be two cover plates, one on each side of the main plates. The thickness of each cover plate is taken as equal to  $0.6t$  to  $0.8t$  where  $t$  is the thickness of the plates to be joined together. The plan and elevation of the single riveted butt joint with double cover plates are shown in Fig. 20.11.

(iii) *Double riveted butt joint with a single cover plate.* In case of double riveted butt joints, two rows of rivets are used on each side of the joint and hence in total there will be four rows of rivets as shown in Fig. 20.12. One cover plate is placed on one side of the rivets. The thickness of the single cover plate is taken as equal to  $t$  to  $1.125t$  where  $t$  is the thickness of the main plate. The distance between the two rows of rivets which are one side of the joint is taken

equal to  $3D$  whereas the distance between two rows of rivets which are on either side of the joint is taken equal to  $3D$ , where  $D$  is the diameter of the rivet. The plan and elevation of the double riveted butt joint with a single cover plate is shown in Fig. 20.12.

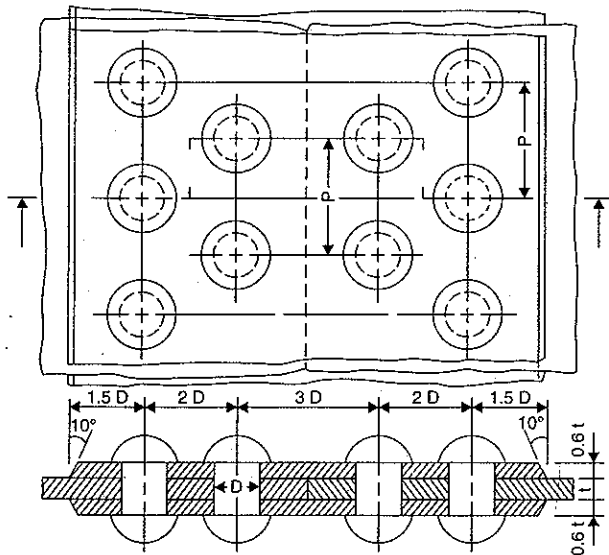

Fig. 20.12. Double riveted butt joint with a single cover plate.

**20.6. FAILURE OF A RIVETED JOINT**

A riveted joint may fail in any one of the following ways :

- (i) Failure due to tearing of the plate between the rivet hole and the edge of the plate,
- (ii) Failure due to tearing of the plates between rivets,
- (iii) Failure due to shearing of rivet,
- (iv) Failure due to crushing (or bearing) of rivet,
- (v) Failure due to crushing of plate.

**20.6.1. Failure Due to Tearing of the Plate between the Rivet hole and the Edge.** If the distance between the centre of the rivet and the nearest edge of the plate (also known as margin,  $m$ ) is not sufficient, the tearing of the plate between the rivet hole and the edge of the plate will take place as shown in Fig. 20.13. This type of failure may be avoided if,

$$m = 1.5d$$

where  $m$  = Margin i.e., distance between the centre of rivet and nearest edge of the plate and  $d$  = Diameter of rivet.

**20.6.2. Failure Due to tearing of the Plate between Rivets of a Row.** The plate will tear between the rivet holes across a row if the tensile stress (due to tensile force  $P$ ) on the section corresponding to the line of rivets is having a large value as shown in Fig. 20.14. In such cases, we consider only a pitch length of the plate.

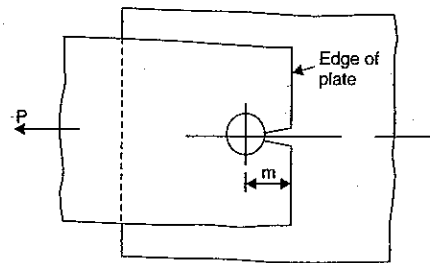

Fig. 20.13

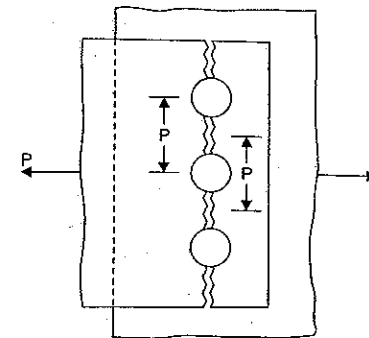

Fig. 20.14

- Let  $p$  = Pitch of the rivet
- $d$  = Diameter of the rivet
- $t$  = Thickness of the Plate
- $P$  = Tensile load acting on the plates
- $\sigma_t$  = Safe tensile stress in the plate
- $P_t$  = Safe tensile load that the plates can withstand for one pitch length

Then safe tensile load per pitch length is given by

$$P_t = \text{Safe tensile stress} \times \text{Area of plate per pitch length} \\ = \sigma_t \times (p - d) \times t \quad \dots(20.1)$$

If the value of tensile load ( $P$ ) is more than the value of  $P_t$  given by equation (20.1), then tearing of plate between the rivets will take place.

**20.6.3. Failure Due to Shearing of Rivet.** If the diameter of the rivets is less than the required diameter, then the rivets will be sheared off as shown in Fig. 20.15 and Fig. 20.16. Fig. 20.15 shows the rivet in a single shear whereas Fig. 20.16 shows the rivets in double shear.

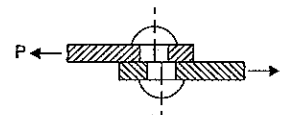

Fig. 20.15. Rivet in single shear.

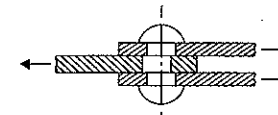

Fig. 20.16. Rivet in double shear.

The cross-sectional area resisting shear, when the rivet is in single shear is equal to  $\frac{\pi}{4} d^2$  whereas the cross-sectional area resisting shear, when the rivet is in double shear is equal to  $2 \times \frac{\pi}{4} d^2$  where  $d$  is the diameter of the rivet.

In a lap joint and in a single cover butt joint, the rivets are in single shear as shown in Fig. 20.17 and Fig. 20.18. But the rivets are in double shear in a double cover butt joint as shown in Fig. 20.19.

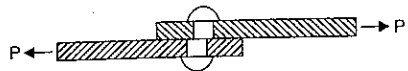

Fig. 20.17. Shearing off a rivet in a lap joint.

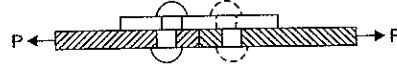

Fig. 20.18. Shearing off a rivet in a single cover butt joint.

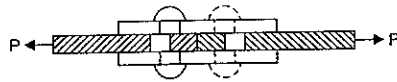

Fig. 20.19. Shearing off a rivet in a double cover butt joint.

Let  $\tau$  = Safe shear stress for the rivet material  
 $d$  = Diameter of rivet

$$A = \text{Area of cross-section of rivet} = \frac{\pi}{4} d^2$$

$P_s$  = Safe load which a rivet can withstand against shearing

$n$  = Number of rivets in one pitch length.

(i) *Safe load per pitch length in case of lap joint.* In case of lap joint the rivets are in single shear.

$$\begin{aligned} \therefore P_s &= 1 \times \frac{\pi}{4} d^2 \times \tau \text{ for a single riveted lap joint} \\ &= 2 \times \frac{\pi}{4} d^2 \times \tau \text{ for a double riveted lap joint} \\ &= 3 \times \frac{\pi}{4} d^2 \times \tau \text{ for a triple riveted lap joint and so on.} \end{aligned}$$

(ii) *Safe load per pitch length in case of butt joint with single cover plates.* The rivets are in single shear. But there is one rivet in a single riveted butt joint on one side of the joint per pitch length (see Fig. 20.18).

$$\begin{aligned} \therefore P_s &= 1 \times \frac{\pi}{4} d^2 \times \tau \text{ for a single riveted butt joint} \\ &= 2 \times \frac{\pi}{4} d^2 \times \tau \text{ for a double riveted butt joint} \\ &= 3 \times \frac{\pi}{4} d^2 \times \tau \text{ for a triple riveted butt joint and so on.} \end{aligned}$$

(iii) *Safe load per pitch length in case of butt joint with double cover plates.* The rivets are in double shear in case of butt joint with double cover plates as shown in Fig. 20.19.

$\therefore$  Safe load which a rivet can withstand in double shear

$$= 2 \times \frac{\pi}{4} d^2 \times \tau$$

$\therefore$  Strength of joint per pitch length against shearing

$$= n \times \left( 2 \times \frac{\pi}{4} d^2 \times \tau \right)$$

where  $n$  = Number of rivets covered per pitch length on one side of the joint

= 1 ..... for a single riveted butt joint

= 2 ..... for a double riveted butt joint

= 3 ..... for a triple riveted butt joint.

In case of a lap joint, the rivets are in single shear.

$\therefore$  Safe load which a rivet can withstand in single shear

$$= \frac{\pi}{4} d^2 \times \tau$$

$\therefore$  Strength of joint per pitch length against shearing

$$= n \times \left( \frac{\pi}{4} d^2 \times \tau \right)$$

where  $n$  = Number of rivets covered per pitch length

= 1 ..... for a single riveted lap joint

= 2 ..... for a double riveted lap joint

= 3 ..... for a triple riveted lap joint.

**20.6.4. Failure Due to Crushing (or bearing) of Rivet or Plate.** In one of the plates in a joint is weaker than the other, the crushing of that plate (or rivet in contact with that plate) will take place. Let the top plate of a lap joint shown in Fig. 20.20 is weaker than the bottom plate. Now if the top plate is pulled by a load  $P$ , the crushing stress (or bearing stress) will be induced between the top plate and the rivet. The plate or rivet will be crushed if these stresses are having large values as shown in Fig. 20.21.

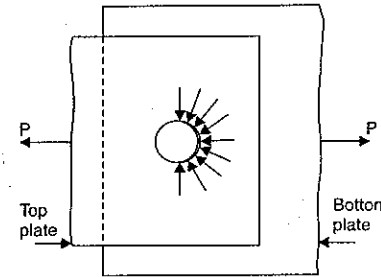

Fig. 20.20

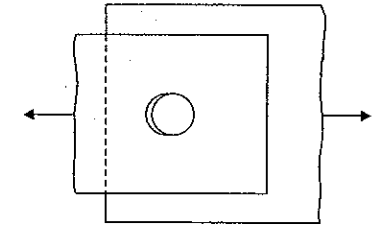

Fig. 20.21

Let  $\sigma_c$  = Allowable crushing stress,

$d$  = Diameter rivet,

$t$  = Thickness of plate,

$P_b$  = Safe load which a rivet can withstand against crushing

=  $\sigma_c \times$  projected area

=  $\sigma_c \times d.t.$

( $\because$  Projected area =  $d.t.$ )

$\therefore$  Strength of the joint per pitch length of the joint against crushing

$$= n \times \sigma_c \times d \times t$$

where  $n$  = Number of rivets covered per pitch length.

## 20.7. STRENGTH OF A RIVETED JOINT

The maximum force, which a riveted joint can withstand without failure, is known as the strength of the joint. The strength of the riveted joint is obtained as :

Let  $\sigma_t$  = Allowable tensile stress in the plate,

$\tau$  = Allowable shear stress for the rivet material,

$\sigma_c$  = Allowable crushing stress of rivet material.

Then per pitch length,

(i) The tearing strength is given by,

$$P = \sigma_t(p - d) \times t$$

(ii) The shearing strength ( $P_s$ ) is given by,

$$P_s = n \times \tau \times \frac{\pi}{4} d^2 \quad \dots \text{if the rivet is in single shear} \quad \dots(20.2)$$

$$= n \times \tau \times \left( 2 \times \frac{\pi}{4} d^2 \right) \dots \text{if the rivet is in double shear} \quad \dots(20.3)$$

where  $n$  = Number of rivets in one pitch length for lap joint

= Number of rivets in one pitch length on one side of the joint for butt joint.

(iii) The crushing strength ( $P_c$ ) or bearing strength ( $P_b$ ) is given by

$$P_c = n \times \sigma_c \times d \times t \quad \dots(20.4)$$

where  $n$  = Number of rivets in one pitch length.

The maximum force, which a riveted joint can transmit without failure, is the least value of  $P_t$ ,  $P_s$  or  $P_c$ . Once the minimum of the three values is reached, the joint will fail. Hence the strength of the joint will be equal to the least value of  $P_t$ ,  $P_s$  and  $P_c$ .

#### 20.8. EFFICIENCY OF A RIVETED JOINT

The efficiency of a riveted joint is the ratio of the strength of the riveted joint to the strength of the solid plate (i.e., strength of unriveted plate). Mathematically

$$\begin{aligned} \text{Efficiency, } \eta &= \frac{\text{Strength of the riveted joint}}{\text{Strength of solid plate}} \\ &= \frac{\text{Least of } P_t, P_s \text{ and } P_c}{P} \quad \dots(20.5) \end{aligned}$$

where  $P$  = Strength of solid plate

$$= \sigma_t \cdot p \cdot t \text{ per pitch length} \quad \dots(20.6)$$

$$\therefore \text{Efficiency, } \eta = \frac{\text{Least of } P_t, P_s \text{ and } P_c}{\sigma_t \cdot p \cdot t} \quad \dots(20.7)$$

**Problem 20.3.** Two plates 8 mm thick are joined by a single riveted lap joint. The diameter of the rivets is 16 mm and pitch = 50 mm. If  $\sigma_t = 120 \text{ N/mm}^2$ ,  $\tau = 90 \text{ N/mm}^2$  and  $\sigma_c = 160 \text{ N/mm}^2$ , determine the efficiency of the joint.

**Sol. Given :**

Thickness of plates,  $t = 8 \text{ mm}$

Dia. of rivet,  $d = 16 \text{ mm}$

Pitch of rivet,  $p = 50 \text{ mm}$

Tensile stress,  $\sigma_t = 120 \text{ N/mm}^2$

Shear stress,  $\tau = 90 \text{ N/mm}^2$

Crushing stress,  $\sigma_c = 160 \text{ N/mm}^2$

Nature of joint = Single riveted lap joint

$\therefore$  The number of rivets in one pitch length,  $n = 1$

Also rivets are in simple shear

(Single riveted lap joint is shown in Fig. 20.7)

Consider the pitch length of the joint.

(i) Tearing strength per pitch length is given by equation (20.1).

$\therefore$  Using equation (20.1),

$$P_t = \sigma_t(p - d) \times t = 120(50 - 16) \times 8 \text{ N} = 32640 \text{ N}$$

(ii) Shearing strength per pitch length is given by equation (20.2),

$$\begin{aligned} P_s &= n \times \tau \times \frac{\pi}{4} d^2 \\ &= 1 \times \tau \times \frac{\pi}{4} d^2 \quad (\because n = 1) \end{aligned}$$

$$= 1 \times 90 \times \frac{\pi}{4} \times 16^2 = 18095.5 \text{ N}$$

(iii) Crushing strength per pitch length is given by equation (20.4),

$$\begin{aligned} P_c &= n \times \sigma_c \times d \times t \\ &= 1 \times 160 \times 16 \times 8 = 20480 \text{ N} \end{aligned}$$

$\therefore$  Least strength per pitch length

$$\begin{aligned} &= \text{Least of } P_t, P_s \text{ and } P_c \\ &= 18095.5 \text{ N} \end{aligned}$$

Strength of the solid plate per pitch length is given by equation (20.6),

$$P = \sigma_t \cdot p \cdot t = 120 \times 50 \times 8 = 48000 \text{ N}$$

$\therefore$  Efficiency of the riveted joint

$$\begin{aligned} &= \frac{\text{Least of } P_t, P_s \text{ and } P_c}{\text{Strength of solid plate}} \\ &= \frac{18095.5 \text{ N}}{48000 \text{ N}} = 0.3769 = 37.69\% \quad \text{Ans.} \end{aligned}$$

**Problem 20.4.** If in problem 20.3, the plates are joined by a double riveted lap joint and pitch = 8 cm determine :

(i) strength of the riveted joint and (ii) efficiency of the riveted joint.

**Sol. Given :**

From problem 20.3,  $t = 8 \text{ mm}$ ,  $d = 16 \text{ mm}$  and  $p = 8 \text{ cm} = 80 \text{ mm}$

$$\sigma_t = 120 \text{ N/mm}^2, \tau = 90 \text{ N/mm}^2 \text{ and } \sigma_c = 160 \text{ N/mm}^2$$

Nature of the joint = Double riveted lap joint

$\therefore$  Number of rivets in one pitch length,  $n = 2$

The rivets are in single shear.

(Double riveted lap joint is shown in Fig. 20.8 and Fig. 20.9)

Consider one pitch length of the joint.

(i) Tearing strength per pitch length is given by equation (20.1).

$$\begin{aligned} P_t &= \sigma_t \times (p - d)t \\ &= 120 \times (80 - 16) \times 8 = 61440 \text{ N.} \end{aligned}$$

(ii) Shearing strength per pitch length is given by equation (20.2).

$$P_s = n \times \tau \times \frac{\pi}{4} d^2$$



$$= 2 \times 90 \times \frac{\pi}{4} \times 16^2 \quad (\because n = 2)$$

$$= 3619 \text{ N}$$

(iii) Crushing strength per pitch length is given by equation (20.4).

$$P_c = n \times \sigma_c \times d \times t \quad (\because n = 2)$$

$$= 2 \times 160 \times 16 \times 8$$

$$= 40960 \text{ N}$$

### Strength of riveted joint

The least of  $P_t$ ,  $P_s$  and  $P_c$  gives the strength of riveted joint. But least of  $P_t$ ,  $P_s$  and  $P_c = 3619 \text{ N}$

$\therefore$  Strength of riveted joint = **3619 N. Ans.**

### Efficiency of the riveted joint

Using equation (20.5),  $\eta = \frac{\text{Least of } P_t, P_s \text{ and } P_c}{P}$

where  $P = \text{Strength of solid plate per pitch length}$   
 $= \sigma_t \cdot p \cdot t = 120 \times 80 \times 8 = 76800 \text{ N}$

$$\therefore \eta = \frac{3619}{76800} = 0.4712 = \mathbf{47.12\% \text{ Ans.}}$$

**Problem 20.5.** Double riveted lap joints are made in the following two ways :

(i) Diameter of rivets = 2 cm, pitch of rivets = 6 cm

(ii) Diameter of rivets = 3 cm, pitch of rivets = 8 cm

If  $\sigma_t = 120 \text{ N/mm}^2$ ,  $\tau = 90 \text{ N/mm}^2$  and  $\sigma_c = 160 \text{ N/mm}^2$ , find out which joint has higher efficiency. The thickness of the plates is 1.2 cm in each case. (AMIE, Winter 1982)

**Sol.** Given :

Tensile stress,  $\sigma_t = 120 \text{ N/mm}^2$

Shear stress,  $\tau = 90 \text{ N/mm}^2$

Crushing stress,  $\sigma_c = 160 \text{ N/mm}^2$

Nature of joint = Double riveted lap joint

$\therefore$  Number of rivets in one pitch length,

$$n = 2$$

The rivets are in single shear

(Double riveted lap joint is shown in Fig. 20.8 and Fig. 20.9)

Consider one pitch length of the joint.

(i) **1st Case**

Dia. of rivets,  $d = 2 \text{ cm} = 20 \text{ mm}$

Pitch of rivets,  $p = 6 \text{ cm} = 60 \text{ mm}$

Thickness of plates  $t = 1.2 \text{ cm} = 12 \text{ mm}$

(a) Tearing strength per pitch length is given by equation (20.1)

$$\therefore P_t = \sigma_t \times (p - d) \times t$$

$$= 120 \times (60 - 20) \times 12 = 57600 \text{ N.}$$

(b) Shearing strength per pitch length is given by equation (20.2).

$$\therefore P_s = n \times \tau \times \frac{\pi}{4} d^2 = 2 \times 90 \times \frac{\pi}{4} \times 20^2 \quad (\because n = 2)$$

$$= 56548 \text{ N.}$$

(c) Crushing strength per pitch length is given by equation (20.4).

$$P_c = n \times \sigma_c \times d \times t \quad (\because n = 2)$$

$$= 2 \times 160 \times 12 \times 20 = 76800 \text{ N}$$

$\therefore$  Least of  $P_t$ ,  $P_s$  and  $P_c = 56548$

Efficiency of the joint is given by equation (20.5).

$$\therefore \eta = \frac{\text{Least of } P_t, P_s \text{ and } P_c}{P}$$

where  $P = \text{Strength of solid plate per pitch length}$

$$= \sigma_t \times p \times t = 120 \times 6 \times 12 = 86400 \text{ N}$$

$$\therefore \text{Efficiency of joint} = \frac{56548}{86400} = 0.6545 = 65.45\%$$

(ii) **2nd case**

Dia. of rivets,  $d = 3 \text{ cm} = 30 \text{ mm}$

Pitch of rivets,  $p = 8 \text{ cm} = 80 \text{ mm}$

Thickness of plate,  $t = 1.2 \text{ cm} = 12 \text{ mm}$

(a) Tearing strength per pitch length is given by equation (20.1).

$$\therefore P_t = \sigma_t \times (p - d) \times t = 120 \times (80 - 30) \times 12 = 72000 \text{ N}$$

(b) Shearing strength per pitch length is given by equation (20.2).

$$\therefore P_s = n \times \tau \times \frac{\pi}{4} d^2 = 2 \times 90 \times \frac{\pi}{4} \times 30^2 \quad (\because n = 2)$$

$$= 127234.5 \text{ N.}$$

(c) Crushing or bearing strength is given by equation (20.4).

$$\therefore P_c = n \times \sigma_c \times d \times t = 2 \times 160 \times 30 \times 12 = 115200 \text{ N}$$

Strength of solid plate per pitch length,

$$P = \sigma_t \times p \times t = 120 \times 80 \times 12 = 115200 \text{ N}$$

Least of  $P_t$ ,  $P_s$  and  $P_c = 72000 \text{ N.}$

$\therefore$  Efficiency is given by

$$\eta = \frac{\text{Least of } P_t, P_s \text{ and } P_c}{\text{Strength of solid plate}} = \frac{72000}{115200} = 0.625 = 62.5\%$$

$\therefore$  The 1st joint has higher efficiency. **Ans.**

**Problem 20.6.** In a double riveted lap joint, the pitch of the rivets is 7.5 cm, thickness of the plate = 1.5 cm and rivet diameter = 2.5 cm. What minimum force per pitch length will rupture the joint when ultimate stresses are  $\sigma_t = 400 \text{ N/mm}^2$ ,  $\tau = 320 \text{ N/mm}^2$  and  $\sigma_c = 640 \text{ N/mm}^2$ .

(AMIE, Winter 1981)

**Sol.** Given :

Nature of the joint = Double riveted lap joint

$\therefore$  Number of rivets in one pitch length,

$$n = 2$$

The rivets are in single shear

Pitch of rivets,  $p = 7.5 \text{ cm} = 75 \text{ mm}$

Thickness of plate,  $t = 1.5 \text{ cm} = 15 \text{ mm}$

Dia. of rivets,  $d = 2.5 \text{ cm} = 25 \text{ mm}$

Ultimate tensile stress,  $\sigma_t = 400 \text{ N/mm}^2$

Ultimate shear stress,  $\tau = 320 \text{ N/mm}^2$

Ultimate Crushing stress,  $\sigma_c = 640 \text{ N/mm}^2$

Consider one pitch length of the joint.

(i) Tearing strength per pitch length is given by equation (20.1)

$$\therefore P_t = \sigma_t \times (p - d) \times t = 400 \times (75 - 25) \times 15 = 300000 \text{ N}$$

(ii) Shearing strength per pitch length is given by equation (20.2).

$$\therefore P_s = n \times \tau \times \frac{\pi}{4} d^2 = 2 \times 320 \times \frac{\pi}{4} \times 25^2 \quad (\because n = 2)$$

$$= 314200 \text{ N.}$$

(iii) Crushing strength per pitch length is given by equation (20.4).

$$\therefore P_c = n \times \sigma_c \times d \times t = 2 \times 640 \times 25 \times 15 \quad (\because n = 2)$$

$$= 480000 \text{ N.}$$

$\therefore$  Minimum force, that will rupture the joint is the least of  $P_t$ ,  $P_s$  and  $P_c$  i.e., 300000 N or 300 kN. **Ans.**

**Problem 20.7.** A thin cylindrical shell 1500 mm in diameter is made of 12 mm plates. The circumferential joint is a single riveted lap joint with 22 mm diameter rivets at a pitch of 50 mm. If the ultimate tensile stress in the plate is 450 N/mm<sup>2</sup> and the ultimate shearing and crushing stresses for the rivets are 300 N/mm<sup>2</sup> and 600 N/mm<sup>2</sup> respectively, calculate the efficiency of the joint. (AMIE, Winter 1974)

**Sol.** Given :

Dia. of shell,  $D = 1500 \text{ mm}$

Thickness of plates,  $t = 12 \text{ mm}$

Dia. of rivets,  $d = 22 \text{ mm}$

Pitch of rivets,  $p = 50 \text{ mm}$

Tensile stress,  $\sigma_t = 450 \text{ N/mm}^2$

Shearing stress,  $\tau = 300 \text{ N/mm}^2$

Crushing stress,  $\sigma_c = 600 \text{ N/mm}^2$

Nature of the joint = Single riveted lap joint

$\therefore$  Number of rivets per pitch length,

$$n = 1.0$$

The rivets are in single shear.

Consider one pitch length of the joint.

(i) Tearing strength of the plate per pitch length is given by equation (20.1).

$$\therefore P_t = \sigma_t (p - d) \times t = 450(50 - 22) \times 12 = 151200 \text{ N.}$$

(ii) Shearing strength per pitch length is given by equation (20.2).

$$\therefore P_s = n \times \tau \times \frac{\pi}{4} d^2 = 1 \times 300 \times \frac{\pi}{4} \times 22^2 \quad (\because n = 1)$$

$$= 114040 \text{ N.}$$

(iii) Crushing (or bearing) strength per pitch is given by equation (20.4).

$$\therefore P_c = n \times \sigma_c \times d \times t = 1 \times 600 \times 22 \times 12 = 158400 \text{ N.}$$

$\therefore$  Least of  $P_t$ ,  $P_s$  and  $P_c = 114040 \text{ N}$

**Efficiency of the joint**

$$\text{Using equation (20.5), } \eta = \frac{\text{Least of } P_t, P_s \text{ and } P_c}{P}$$

where  $P =$  strength of solid plate per pitch length

$$= \sigma_t \times p \times t = 450 \times 50 \times 12 = 270000 \text{ N}$$

$$\therefore \eta = \frac{114040}{270000} = 0.4224 = 42.24\%. \quad \text{Ans.}$$

**Problem 20.8.** A single riveted double cover butt joint is used to connect two plates 15 mm thick. The rivets are 26 mm in diameter and are provided at a pitch of 10 cm. The allowable stresses in tension, shear and crushing are 130 N/mm<sup>2</sup>, 75 N/mm<sup>2</sup> and 150 N/mm<sup>2</sup> respectively, find :

(i) Safe load per pitch length of the joint, and

(ii) Efficiency of the joint.

**Sol.** Given :

Nature of joint = Single riveted double cover butt joint.

$\therefore$  Number of rivets per pitch length on one side\* of the joint.

$$n = 1.$$

As the joint is double cover butt joint, hence the rivets are in double shear.

Thickness of plates,  $t = 15 \text{ mm}$

Dia. of rivets,  $d = 25 \text{ mm}$

Pitch of rivets,  $p = 10 \text{ cm} = 100 \text{ mm}$

Allowable tensile stress,  $\sigma_t = 130 \text{ N/mm}^2$

Shear stress,  $\tau = 75 \text{ N/mm}^2$

Crushing stress,  $\sigma_c = 150 \text{ N/mm}^2$

Consider one pitch length of the joint.

(a) Tearing strength per pitch length is given an equation (20.1).

$$\therefore P_t = \sigma_t \times (p - d) \times t = 130 \times (100 - 25) \times 15 = 146250 \text{ N.}$$

(b) Shearing strength per pitch length is given by equation (20.3).

$$\therefore P_s = n \times \tau \times \left( 2 \times \frac{\pi}{4} d^2 \right) \quad (\because \text{rivets are in double shear})$$

$$= 1 \times 75 \times \left( 2 \times \frac{\pi}{4} \times 25^2 \right) \text{ N} = 73631 \text{ N.}$$

(c) Crushing strength per pitch length is given by equation (20.4).

$$\therefore P_c = n \times \sigma_c \times d \times t = 1 \times 150 \times 25 \times 15 \text{ N} = 56250 \text{ N.}$$

(i) Safe load per pitch length of the joint. The safe load per pitch length of the joint will be the least of the three values of  $P_t$ ,  $P_s$  and  $P_c$ . But the value of  $P_c$  is least.

$\therefore$  Safe load = 56250 N. **Ans.**

\*Please note that in case of butt joint the number of rivets on one side of joint per pitch length are taken.

(ii) Efficiency of the joint

$$\text{Using equation (20.5), } \eta = \frac{\text{Least of three values of } P_t, P_s \text{ and } P_c}{\text{Strength of solid plate}}$$

$$= \frac{56250}{\text{Strength of solid plate}}$$

But strength of solid plate is given by equation (20.6) as

$$P = \sigma_t \times p \times t = 130 \times 100 \times 15 = 195000 \text{ N}$$

$$\therefore \eta = \frac{56250}{195000} = 0.2884 = 28.84\% \text{ Ans.}$$

**Problem 20.9.** If in problem 20.8, the single butt joint is having a single cover plate instead of double cover plates, find : (i) Safe load per pitch length of the joint and (ii) Efficiency of the joint.

**Sol.** Given :

Nature of the joint = Single riveted butt joint with a single cover plate.

$\therefore$  Number of rivets per pitch length on one side of the joint,

$$n = 1.$$

As the butt joint is having a single cover plate, the rivets will be in single shear.

The other data from problem 20.8 are :

$$t = 15 \text{ mm}, \quad d = 25 \text{ mm}, \quad p = 100 \text{ mm},$$

$$\sigma_t = 130 \text{ N/mm}^2, \quad \tau = 75 \text{ N/mm}^2 \text{ and } \sigma_c = 150 \text{ N/mm}^2.$$

Consider one pitch length of the joint.

(a) Tearing strength per pitch length is given by equation (20.1).

$$\therefore P_t = \sigma_t \times (p - d) \times t = 130 \times (100 - 25) \times 15 \text{ N} = 146250 \text{ N.}$$

(b) Shearing strength per pitch length is given by equation (20.2).

$$\therefore P_s = n \times \tau \times \left( \frac{\pi}{4} d^2 \right) \quad (\because \text{ Rivets are in single shear})$$

$$= 1 \times 75 \times \left( \frac{\pi}{4} \times 25^2 \right) \text{ N} \quad (\because n = 1)$$

$$= 36815.5 \text{ N.}$$

(c) The crushing strength per pitch length is given by equation (20.4).

$$\therefore P_c = n \times \sigma_c \times d \times t$$

$$= 1 \times 150 \times 25 \times 15 \text{ N} \quad (\because n = 1)$$

$$= 56250 \text{ N.}$$

(i) Safe load per pitch length of the joint

The least of three values of  $P_t$ ,  $P_s$  and  $P_c$  is the safe load on the joint. But the least of three values is of  $P_s$  i.e., 36815.5 N.

$\therefore$  Safe load per pitch length of the joint

$$= 36815.5 \text{ N. Ans.}$$

(ii) Efficiency of the joint

$$\text{Using equation (20.5), } \eta = \frac{\text{Least of three values of } P_t, P_s \text{ and } P_c}{\text{Strength of solid plate}}$$

$$= \frac{36815.5}{\sigma_t \cdot p \cdot t} \quad (\because \text{ Strength of solid plate} = \sigma_t \cdot p \cdot t.)$$

$$= \frac{36815.5}{130 \times 100 \times 15} = 0.1888 = 18.88\% \text{ Ans.}$$

**Problem 20.10.** A single riveted double cover butt joint in a structure is used for connecting two plates 12 mm thick. The diameter of the rivets is 24 mm. The permissible stresses are 120 N/mm<sup>2</sup> in tension, 100 N/mm<sup>2</sup> in shear and 200 N/mm<sup>2</sup> in bearing. Calculate the necessary pitch and efficiency of the joint. (AMIE, May 1967)

**Sol.** Given :

Nature of the joint = Single riveted double cover butt joint.

$\therefore$  Number of rivets per pitch length on one side of the joint,

$$n = 1$$

As the butt joint is having double cover plates, the rivets will be in double shear.

Thickness of plates,  $t = 12 \text{ mm}$

Diameter of rivets,  $d = 24 \text{ mm}$

Tensile stress,  $\sigma_t = 120 \text{ N/mm}^2$

Shearing stress,  $\tau = 100 \text{ N/mm}^2$

Bearing stress,  $\sigma_c = 200 \text{ N/mm}^2$

Let  $p =$  Pitch of the joint and

$\eta =$  Efficiency of the joint.

Consider one pitch length of the joint.

(i) Tearing strength per pitch length is given by equation (20.1).

$$\therefore P_t = \sigma_t \times (p - d) \times t$$

$$= 120 \times (p - 24) \times 12 = 1440(p - 24) \text{ N.} \quad \dots(i)$$

(ii) Shearing strength per pitch length is given by equation (20.3).

$$\therefore P_s = n \times \sigma \times \left( 2 \times \frac{\pi}{4} d^2 \right) \quad (\because \text{ rivets are in double shear})$$

$$= 1 \times 100 \times \left( 2 \times \frac{\pi}{4} \times 24^2 \right) \text{ N} \quad (\because n = 1)$$

$$= 90500 \text{ N.}$$

(iii) Bearing (or crushing) strength per pitch length is given by equation (20.4).

$$\therefore P_c = n \times \sigma_c \times d \times t = 1 \times 200 \times 24 \times 12 \text{ N} = 57600 \text{ N}$$

Equating  $P_t$  to the lesser of the forces  $P_s$  and  $P_c$ , we get

$$1440(p - 24) = 57600$$

$$p = \frac{57600}{1440} + 24 = 40 + 24 = 64 \text{ mm. Ans.}$$

Now strength of solid plate

$$= \sigma_t \times p \times t$$

$$= 120 \times 64 \times 12 = 92160 \text{ N}$$

$$\text{Efficiency, } \eta = \frac{\text{Least force}}{\text{Strength of solid plate}} = \frac{57600}{92160} = 0.625 = 62.5\% \text{ Ans.}$$

**Problem 20.11.** Two plates of 12 mm thickness are connected by a double riveted cover butt joint using 18 mm diameter rivets at a pitch of 8 cm. If the ultimate tensile stress in plate and shearing and bearing stresses in the rivets are 460 N/mm<sup>2</sup>, 320 N/mm<sup>2</sup> and 640 N/mm<sup>2</sup> respectively, find the pull per pitch length at which the joint will fail. (AMIE, Summer 1974)

**Sol. Given :**

Thickness of plates,  $t = 12$  mm

Nature of the joint = Double riveted double cover butt joint.

∴ Number of rivets per pitch length of one side of the joint,  
 $n = 2$ .

As the butt joint is having double cover plates, the rivets will be in double shear.

Dia. of rivets,  $d = 18$  mm

Pitch,  $p = 8$  cm = 80 mm

Tensile stress,  $\sigma_t = 460$  N/mm<sup>2</sup>

Shearing stress,  $\tau = 320$  N/mm<sup>2</sup>

Bearing stress,  $\sigma_c = 640$  N/mm<sup>2</sup>

Consider on pitch length of the joint.

(i) Tearing strength per pitch length is given by equation (20.1).

$$\therefore P_t = \sigma_t \times (p - d) \times t = 460(80 - 18) \times 12 \text{ N} = 34,2200 \text{ N}$$

(ii) Shearing strength per pitch length is given by equation (20.3)

$$\begin{aligned} \therefore P_s &= n \times \tau \times \left( 2 \times \frac{\pi}{4} d^2 \right) \quad (\because \text{Rivets are in double shear}) \\ &= 2 \times 320 \times \left( 2 \times \frac{\pi}{4} \times 18^2 \right) \quad (\because n = 2) \\ &= 325800 \text{ N} \end{aligned}$$

(iii) Bearing (or crushing) strength per pitch length is given by equation

$$\therefore P_c = n \times \sigma_c \times d \times t = 2 \times 640 \times 18 \times 12 \text{ N} = 276500 \text{ N}$$

The pull per pitch length at which the joint will fail is the least of the above three forces. But the least of the above three forces is 276500 N.

∴ The joint will fail at a pull of **276500 N. Ans.**

**Efficiency of the joint**

$$\begin{aligned} \text{Using equation (20.5), } \eta &= \frac{\text{Least of the three forces of } P_t, P_s \text{ and } P_c}{\text{Strength of solid plate}} \\ &= \frac{276500}{\sigma_t \times p \times t} \quad (\because \text{Strength of solid plate} = \sigma_t \cdot p \cdot t) \\ &= \frac{276500}{460 \times 80 \times 12} \\ &= 0.6262 = \mathbf{62.62\%}. \text{ Ans.} \end{aligned}$$

**Problem 20.12.** A double riveted double cover butt joint is used for connecting plates 1.2 cm thick. The diameter of the rivets is 2.2 cm. The permissible stresses are 100 N/mm<sup>2</sup> in tension, 80 N/mm<sup>2</sup> in shear and 160 N/mm<sup>2</sup> in bearing. Draw a neat sketch of the joint and calculate the necessary pitch and efficiency of the joint. (AMIE, November 1966)

**Sol. Given :**

Nature of the joint = Double riveted double cover butt joint

∴ Number of the rivets per pitch length on one side of the joint,  
 $n = 2$ .

The butt joint is having double cover plates and hence the rivets will be in double shear.

Thickness of plates,  $t = 1.2$  cm = 12 mm

Diameter of rivets,  $d = 2.2$  cm = 22 mm

Tensile stress,  $\sigma_t = 100$  N/mm<sup>2</sup>

Shear stress,  $\tau = 80$  N/mm<sup>2</sup>

Crushing or bearing stress,  $\sigma_c = 160$  N/mm<sup>2</sup>

Let  $p$  = Pitch of the joint and

$\eta$  = Efficiency of the joint

Consider one pitch length of the joint.

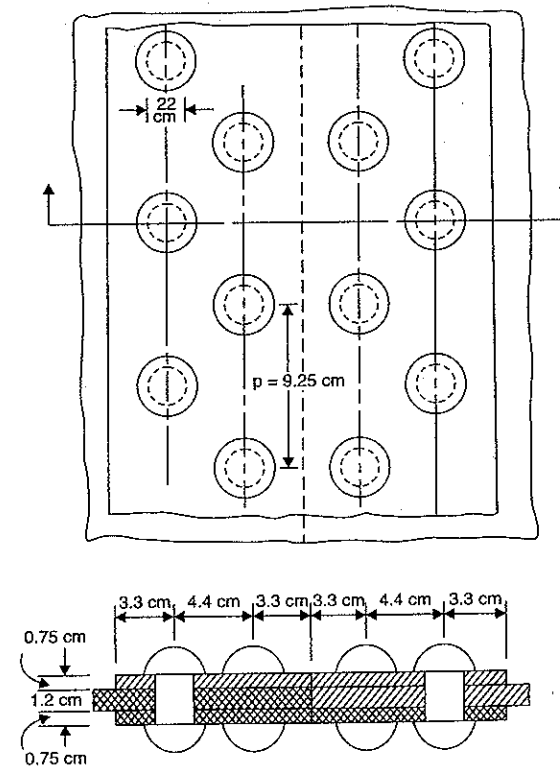

Fig. 20.22

(i) Tearing strength per pitch length is given by equation (20.1).

$$P_t = \sigma_t \times (p - d) \times t = 100(p - d) \times 12 \\ = 1200(p - 22) \text{ N}$$

(ii) Shearing strength per pitch length is given by equation (20.3).

$$\therefore P_b = n \times \tau \times \left( 2 \times \frac{\pi}{4} d^2 \right) \quad (\because \text{Rivets are in double shear}) \\ = 2 \times 80 \times \left( 2 \times \frac{\pi}{4} \times 22^2 \right) \text{ N} = 121600 \text{ N}$$

(iii) Bearing (or crushing) strength per pitch length is given by equation (20.4).

$$\therefore P_c = n \times \sigma_c \times d \times t = 2 \times 160 \times 22 \times 12 \text{ N} = 84480 \text{ N}$$

Equating  $P_t$  to the lesser of the forces  $P_s$  and  $P_c$ , we get

$$1200(p - 22) = 84480$$

$$\therefore p = \frac{84480}{1200} + 22 = 70.4 + 22 \\ = 92.4 \text{ mm say } 92.5 \text{ mm. Ans.}$$

Now strength of the solid plate

$$= \sigma_p \cdot p \cdot t = 100 \times 92.5 \times 12 = 111000 \text{ N}$$

$\therefore$  Efficiency of the joint,

$$\eta = \frac{\text{Least force}}{\text{Strength of solid plate}} \\ = \frac{84480}{111000} = 0.761 = 76.1\%. \text{ Ans.}$$

The neat sketch of the joint (plan and elevation) is shown in Fig. 20.22.

**Problem 20.13.** Find the suitable pitch for a riveted lap joint for plates 1 cm thick if safe working stresses in tension in the plates and crushing and shearing of the rivet material are respectively  $150 \text{ N/mm}^2$ ,  $212.5 \text{ N/mm}^2$  and  $94.5 \text{ N/mm}^2$  in the following types of joints :

(i) Single riveted and (ii) Double riveted. Find also the efficiency of the joint in the above two cases. Take  $d = 6\sqrt{t}$ . (AMIE, Summer 1977)

**Sol.** Given :

Thickness of plate,  $t = 1 \text{ cm} = 10 \text{ mm}$

Safe tensile stress,  $\sigma_t = 150 \text{ N/mm}^2$

Safe crushing stress,  $\sigma_c = 212.5 \text{ N/mm}^2$

Safe shearing stress,  $\tau = 94.5 \text{ N/mm}^2$

Let  $d = \text{Dia. of the rivet in mm.}$

(i) Single riveted lap joint

No. of rivets per pitch length,  $n = 1$ .

Dia. of rivet,  $d = 6\sqrt{t} = 6\sqrt{10} = 19 \text{ mm say } 20 \text{ mm}$

The rivets in lap joint are in single shear.

Consider one pitch length of the joint.

Shearing strength per pitch length is given by equation (20.2).

$$\therefore P_s = n \times \sigma_t \times \frac{\pi}{4} d^2 \quad (\because n = 1)$$

$$= 1 \times 94.5 \times \frac{\pi}{4} \times 22^2 = 29688 \text{ N}$$

Crushing strength per pitch length is given by equation (20.4),

$$\therefore P_c = n \times \sigma_c \times d \times t \\ = 1 \times 212.5 \times 20 \times 10 \quad (\because n = 1) \\ = 42500 \text{ N}$$

Tearing strength per pitch length is given by equation (20.1),

$$\therefore P_t = (p - d) \times t \times \sigma_t = (p - 20) \times 10 \times 150$$

Equating the tearing strength to the lesser of crushing and shearing strengths

$$150(p - 20) = 29688$$

$$\therefore p = \frac{29688}{150} + 20 = 39.8 \text{ mm}$$

Generally the pitch should not be less than  $3d$  i.e.,  $3 \times 20 = 60 \text{ mm}$ . Hence provide a pitch of 60 mm. **Ans.**

**Efficiency of the riveted joint**

$$\text{Using equation (20.5), } \eta = \frac{\text{Least of } P_t, P_s, P_c}{\text{Strength of solid plate per pitch length}} \\ = \frac{29688}{\text{Strength of solid plate per pitch length}}$$

But strength of solid plate per pitch length

$$= \sigma_p \cdot p \cdot t = 150 \times 60 \times 10 = 90000 \text{ N.}$$

$$\therefore \text{Efficiency, } \eta = \frac{29688}{90000} = 0.33 = 33\%. \text{ Ans.}$$

(ii) Double riveted lap joint

Number of rivets per pitch length = 2

The rivets in double riveted lap joint are also in single shear. Consider one pitch length of the joint.

Shearing strength per pitch length is given by equation (20.2).

$$\therefore P_s = n \times \tau \times \frac{\pi}{4} d^2 \\ = 2 \times 94.5 \times \frac{\pi}{4} \times 20^2 \quad (\because n = 2) \\ = 59376 \text{ N}$$

Crushing strength per pitch length is given by equation (20.4).

$$\therefore P_c = n \times \sigma_c \times d \times t = 2 \times 212.5 \times 20 \times 10 = 85000 \text{ N}$$

Tearing strength per pitch length is given by equation (20.1),

$$\therefore P_t = \sigma_t \times (p - d) \times t = 150 \times [p - 20] \times 10 = 1500(p - 20)$$

Equating the tearing strength to the lesser of crushing and shearing strengths, we get

$$1500(p - 20) = 59376$$

$$\therefore p = \frac{59376}{1500} + 20 = 59.6 \text{ mm say } 60 \text{ mm. Ans.}$$

**Efficiency of the joint**

$$\text{Using equation (20.5), } \eta = \frac{\text{Least of } P_t, P_s \text{ and } P_c}{\text{Strength of solid plate per pitch length}}$$

$$= \frac{59376}{\sigma_t \times p \times t} = \frac{52376}{150 \times 60 \times 10} = 0.6597 = \mathbf{65.97\%}. \quad \text{Ans.}$$

**20.9. DESIGN OF A RIVETED JOINT**

Designing a riveted joint means to find the following quantity :

1. Diameter of rivets,
2. Pitch of rivets,
3. No. of rivets required for the joint, and
4. Thickness of the cover plates (in case of butt joints).

**1. Diameter of rivets ( $d$ )**

The diameter of rivets is calculated by using the relation :

$$d = 1.6 \sqrt{t} \quad \dots(20.8)$$

where  $d$  = Diameter of the rivets in cm, and

$t$  = Thickness of the main plates in cm.

The diameter of the rivets can also be calculated from the relation :

$$d = 6\sqrt{t} \quad \dots(20.9)$$

where  $d$  and  $t$  are in mm.

**2. Pitch of rivets ( $p$ )**

(i) If the efficiency of the riveted joint is given, then pitch is obtained from the relation :

$$\eta = \frac{p-d}{p} \quad \dots(20.10)$$

In the above relation  $\eta$  and diameter ( $d$ ) are known hence the pitch ( $p$ ) can be obtained.

(ii) If the efficiency of the joint is not known, then pitch is obtained by considering the shearing strength and crushing strength of the joint per pitch length. The minimum of these two values are equated with the tearing strength of the plate per pitch length.

$$\text{Or Minimum of } P_s \text{ or } P_c = \sigma_t \times (p-d) \times t \quad \dots(20.11)$$

where  $P_s$  = Shearing strength per pitch length,

$P_c$  = Bearing strength per pitch length,

$\sigma_t$  = Safe tensile stress,

$d$  = diameter of rivets,

$t$  = Thickness of plate, and

$p$  = pitch.

The value of the pitch obtained from equations (20.10) or (20.11) should be between 2.5 to 3.0 times the rivet diameter.

**3. No. of rivet required for a joint**

The number of rivets in a small joint are obtained from the relation

$$n = \frac{P}{\text{Least rivet value for shearing and bearing}} \quad \dots(20.12)$$

where  $P$  = Force or pull to be transmitted across the joint.

The rivet value is obtained by considering shearing strength and bearing strength of one rivet. The minimum of the two gives the least rivet value.

**4. Thickness of cover plates (in case of butt joints)**

The thickness of the cover plates is obtained from the relations :

$$t_1 = 1.125t \quad \dots \text{for ordinary butt joint with a single cover plate.} \quad \dots(20.13)$$

$$= 0.625t \quad \dots \text{for a butt joint with double cover plates} \quad \dots(20.14)$$

where  $t$  = Thickness of the main plates and

$t_1$  = Thickness of cover plates.

**Problem 20.14.** Two plates 10 mm thick are joined by a single riveted lap joint. The plates are subjected to a load of 200 kN. If the permissible tensile, shear and bearing stresses are 120 N/mm<sup>2</sup>, 100 N/mm<sup>2</sup> and 160 N/mm<sup>2</sup> respectively, determine :

- (i) diameter of the rivets,
- (ii) pitch of the rivet,
- (iii) number of rivets, and
- (iv) efficiency of the joint.

**Sol.** Given :

Thickness of plates,  $t = 10$  mm

Nature of the joint = Single riveted lap joint

$\therefore$  Number of rivets per pitch length = 1

And rivets are in single shear

Load or pull through which the plates are subjected,

$$P = 200 \text{ kN} = 200,000 \text{ N}$$

Permissible tensile stress,  $\sigma_t = 120 \text{ N/mm}^2$

Permissible shear stress,  $\tau = 100 \text{ N/mm}^2$

Permissible crushing stress,  $f_c = 160 \text{ N/mm}^2$

(i) The diameter of rivets is obtained by using equation (20.8).

$$\therefore d = 6\sqrt{t}$$

$$= 6 \times \sqrt{10} = 18.97 \text{ mm say } \mathbf{19.0 \text{ mm.}} \quad \text{Ans.}$$

(ii) Pitch of the rivet

First find the shearing strength and bearing strength of one rivet. The rivets are in single shear.

$\therefore$  Shear strength of one rivet

$$P_s = \frac{\pi}{4} d^2 \times \tau = \frac{\pi}{4} \times 19^2 \times 100 = 28352.8 \text{ N}$$

Crushing strength of one rivet,

$$P_c = d \times t \times \sigma_c = 19 \times 10 \times 160 \quad (f_c = 160)$$

$$= 30400 \text{ N}$$

$\therefore$  Least rivet value = 28352.8 N

Now using equation (20.11).

Minimum of  $P_c$  or  $P_s = \sigma_t [p-d] \times t$

where  $\sigma_t [p-d] \times t$  is the tearing strength of the plate per pitch length. But minimum of  $P_c$  or  $P_s = 28352.8 \text{ N}$

$$\therefore 28352.8 = 120(p-19) \times 10$$

$$\therefore p - 19 = \frac{28352.8}{1200}$$

$$\text{or } p = \frac{28352.8}{1200} + 19 = 42.6 \text{ mm}$$

But the pitch should not be less than  $2.5 d$  i.e., less than  $2.5 \times 19 = 47.5$  mm

Hence provide a pitch of 47.5 mm. Hence  $p = 47.5$  mm. **Ans.**

(iii) Number of rivets

Let  $n$  = number of rivets.

$$\text{Using equation (20.12), } n = \frac{P}{\text{Least rivet value for shearing and bearing}}$$

where  $P$  = Pull to be transmitted across the joint

$$= 200000 \text{ N (given)}$$

and least rivet value = 28352.8 N

$$\therefore n = \frac{200000}{28352.8} = 7.054 \text{ say } 8. \text{ Ans.}$$

(Please note that the number of rivets are always taken the next higher integer).

(iv) Efficiency of the joint

$$\text{Using equation (20.7), } \eta = \frac{\text{Least of } P_t, P_s \text{ and } P_c}{\sigma_t \cdot p \cdot t} = \frac{28352.8}{120 \times 47.5 \times 10} = 0.4974 = 49.74\%. \text{ Ans.}$$

**Problem 20.15.** Design a double cover butt joint to connect two plates 1.5 cm thick and 20 cm wide. The safe stresses are  $\sigma_t = 125 \text{ N/mm}^2$ ,  $\tau = 90 \text{ N/mm}^2$  and  $\sigma_c = 200 \text{ N/mm}^2$ . Also determine the efficiency of the joint.

**Sol.** Given :

Thickness of the plate,  $t = 1.5 \text{ cm} = 15 \text{ mm}$

Nature of the joint = Double cover butt joint.

$\therefore$  The rivets are in double shear

Width of the plates,  $b = 20 \text{ cm} = 200 \text{ mm}$

The safe tensile stress,  $\sigma_t = 125 \text{ N/mm}^2$

The safe shear stress,  $\tau = 90 \text{ N/mm}^2$

The safe crushing stress,  $\sigma_c = 200 \text{ N/mm}^2$

In this joint, the pull or load transmitted across the joint is not given. This is obtained by considering the plates to be weakened by a single hole in the last row.

$\therefore$  Tearing strength of the plate across the last row

$$= \sigma_t(b - d) \times t = 125(200 - d) \times 15 \text{ N} \quad \dots(i)$$

(i) Diameter of the rivet ( $d$ )

$$\text{Using equation (20.8), } d = 1.9\sqrt{t}$$

$$= 1.9\sqrt{1.5} = 2.33 \text{ cm say } 2.4 \text{ or } 24 \text{ mm. Ans.}$$

Substituting the value of  $d$  in equation (i), we get the safe strength of the plate as

$$P = 125(200 - 24) \times 15 = 33000 \text{ N} \quad \dots(ii)$$

(ii) No. of rivets

First of all, let us find the rivet value, i.e., the pulls required for shearing and crushing of a rivet.

$\therefore$  Shearing strength of one rivet,

$$P_s = 2 \times \tau \times \frac{\pi}{4} d^2 \quad (\because \text{ Rivets are in double shear})$$

$$= 2 \times 90 \times \frac{\pi}{4} \times (24)^2 = 81160 \text{ N}$$

Crushing strength of one rivet,

$$P_c = \sigma_c \times t \times d = 200 \times 15 \times 24 = 72000 \text{ N}$$

$\therefore$  Rivet value is the least of  $P_s$  and  $P_c$ .

Hence rivet value = 72000 N

$\therefore$  Number of rivets are given by equation (20.12) as

$$n = \frac{P}{\text{Rivet value}} = \frac{330000}{72000} = 4.6 \quad (\because P \text{ from equation (ii)} = 330000 \text{ N})$$

Let us provide 5 rivets. **Ans.**

(iii) Pitch of the rivets ( $p$ )

Using equation (20.11)

Minimum of  $P_c$  or  $P_s = f_t[p - d] \times t$

$$\therefore 72000 = 125(p - 24) \times 15$$

$$\therefore p - 24 = \frac{72000}{125 \times 15} \quad \text{or } p = \frac{72000}{125 \times 15} + 24 = 62.4 \text{ mm}$$

But the pitch should not be less than  $2.5 d$

$$\text{or } 2.5 \times 24 = 60 \text{ mm}$$

$\therefore$  Let us provide a pitch of 62.5 cm. **Ans.**

**Thickness of cover plates ( $t_1$ )**

Using equation (20.14),  $t_1 = 0.625 \times t = 0.625 \times 15 = 9.37 \text{ mm}$

$\therefore$  Let us provide 10 mm thick cover plates. **Ans.**

**Efficiency of the joint**

$$\text{Using equation (20.10), } \eta = \frac{p - d}{p}$$

$$= \frac{62.5 - 24}{62.5} = \frac{38.5}{62.5} = 0.616 = 61.6\%. \text{ Ans.}$$

### HIGHLIGHTS

1. Riveted joints are mainly of two types i.e., lap joint and butt joint.
2. In case of lap joint, the edges of the plates to be joined together overlap each other whereas in case of butt joint the edges of the plates butt (i.e., touch) against each other.

3. The lap joints may be : (i) Single riveted lap joint, (ii) double riveted lap joint and (iii) triple riveted lap joint.
4. In case of single riveted lap joint, only one row of rivets is used for connecting two plates whereas in case of double riveted lap joint, two rows of rivets are used for the connection.
5. In case of a butt joint, atleast two rows of rivets one on each side of the joint, are required.
6. Butt joints are also classified as : (i) Single riveted butt joint, (ii) double riveted butt joint, and (iii) tripple butt joint.
7. In case of a single riveted butt joint, one row of rivets is used on each side of the joint. Hence in total there are two rows of rivets.
8. In case of a chain riveted joint, every rivet of a row is opposite to the other rivet of the other row.
9. In case of a zig-zag riveted joint, every rivet is in the middle of the two rivets of the opposite row.
10. The failure due to tearing of the plate between the rivet hole and the edge may be avoided if margin is equal to  $1.5d$  where  $d$  = diameter of rivet.
11. The safe tensile load per pitch length is given by

$$P_t = \sigma_t \times (p - d) \times t$$

where  $p$  = Pitch,

$d$  = Diameter of rivet, and

$t$  = Thickness of the plate.

12. In a lap joint and in a single cover butt joint, the rivets are in single shear. But in case of double cover butt joint, the rivets are in double shear.
13. Safe shear load per pitch length in case of lap joint is given by,

$$P_s = 1 \times \frac{\pi}{4} d^2 \times \tau \quad \dots \text{For a single riveted lap joint}$$

$$= 2 \times \frac{\pi}{4} d^2 \times \tau \quad \dots \text{For a double riveted lap joint}$$

$$= 3 \times \frac{\pi}{4} d^2 \times \tau \quad \dots \text{For a triple riveted lap joint.}$$

14. Safe shear load per pitch length in case of butt joint with double cover plates is given by,

$$P_t = n \times \left( 2 \times \frac{\pi}{4} d^2 \times \tau \right)$$

where  $n$  = Number of rivets covered per pitch length on one side of the joint

= 1 ... For a single riveted butt joint

= 2 ... For a double riveted butt joint and so on.

15. The minimum force, which a riveted joint can withstand without failure, is known as the strength of the joint. It is equal to the least value of  $P_t$ ,  $P_s$  and  $P_c$ , where

$$P_t = \sigma_t \times (p - d) \times t,$$

$$P_s = n \times \tau \times \frac{\pi}{4} d^2 \quad \dots \text{if the rivet is in single shear}$$

$$= n \times \tau \times \left( 2 \times \frac{\pi}{4} d^2 \right) \quad \dots \text{if the rivet is double shear}$$

and  $P_c = n \times \sigma_c \times d \times t$

where  $n$  = Number of rivets in one pitch length.

16. Efficiency of a riveted joint is the ratio of the strength of the joint to the strength of the solid plate. Mathematically,

$$n = \frac{\text{Strength of riveted joint}}{\text{Strength of solid plate}} = \frac{\text{Least value of } P_t, P_s \text{ and } P_c}{P}$$

where  $P = \sigma_t \times p \times t$ .

17. Design of a riveted joint means to find : (i) diameter of rivets, (ii) pitch of rivets, (iii) number of rivets required for the joint, and (iv) thickness of the cover plates (in case of butt joints).
18. Diameter of rivets is given by

$$d = 19 \sqrt{t} \quad \text{when } d \text{ and } t \text{ are in cm}$$

$$= 6 \sqrt{t} \quad \text{when } d \text{ and } t \text{ are in mm.}$$

19. The pitch of rivets is obtained either from the relation

$$n = \frac{p - d}{p}$$

or from the relation.

Minimum of  $P_s$  or  $P_c = \sigma_t \times (p - d) \times t$ .

20. The number of rivets in a small joint are obtained from

$$n = \frac{\text{Force transmitted across the joint}}{\text{Least rivet value for shearing and bearing}}$$

21. Thickness of cover plates in case of butt joints is given by

$$t_1 = 1.125t \quad \dots \text{for single cover butt joint}$$

$$= 0.625t \quad \dots \text{for double cover butt joint.}$$

### EXERCISE 20

#### (A) Theoretical Questions

1. Define the terms : riveted joint, lap joint and butt joint.
2. What are the different types of lap joint and butt joint ? Explain clearly with neat sketches.
3. Explain the terms : Chain riveted joint, zig-zag riveted joint and diamond riveted joint.
4. Draw neat sketches (plan and elevation) of the following riveted joints.
  - (i) Single riveted lap joint,
  - (ii) Double riveted lap joint having chain riveting, and
  - (iii) Double riveted lap joint having zig-zag riveting.
5. Describe the different types of failure of a riveted joint.
6. What should be the value of margin so that there is no failure due to tearing of the plate between the rivet hold and the edge of the plate.
7. Prove that the safe tensile load per pitch length is given by
 
$$P_t = \sigma_t \times (p - d) \times t$$
 where  $\sigma_t$  = Safe tensile stress in the plate,  
 $p$  = Pitch of the rivet,  
 $d$  = Diameter of the rivet, and  
 $t$  = Thickness of the plate.
8. Prove the statement that in a lap joint the rivets are in single shear whereas in double cover butt joint, the rivets are in double shear.



9. Find an expression for the safe shear load per pitch length in case of a butt joint with double cover plates.
10. What do you mean by strength of a riveted joint? Find an expression for the tearing strength, shearing strength and bearing strength of a riveted joint.
11. Define the efficiency of a riveted joint. How will you find the efficiency of a riveted joint?
12. What do you mean by 'Design of a riveted joint'? While designing a riveted joint, how will you find different quantities?

### (B) Numerical Problems

1. Two plates 10 mm thick are joined by single riveted lap joint. The diameter of the rivets is 20 mm and pitch = 60 mm. If  $\sigma_t = 125 \text{ N/mm}^2$ ,  $\tau = 80 \text{ N/mm}^2$  and  $\sigma_c = 160 \text{ N/mm}^2$ , determine the efficiency of the joint. [Ans. 33.51%]
2. If in problem 1, the plates are joined by a double riveted lap joint and pitch = 80 mm, determine : (i) strength of the riveted joint and (ii) efficiency of the riveted joint. [Ans. (i) 50.265 kN, (ii) 50.26%]
3. Double riveted lap joints are made in the following two ways :  
(i) Diameter of rivets = 2.5 cm, pitch of rivets = 7.5 cm  
(ii) Diameter of rivets = 3.5 cm, pitch of rivets = 8.5 cm  
If  $\sigma_t = 120 \text{ N/mm}^2$ ,  $\tau = 90 \text{ N/mm}^2$  and  $\sigma_c = 160 \text{ N/mm}^2$ , find out which joint has higher efficiency. The thickness of the plates in each case is 1.3 cm. [Ans. 1st joint]
4. In a double riveted lap joint, the pitch of the rivets is 9.0 cm, thickness of the plate = 1.6 cm and rivet diameter = 2.6 cm. What minimum force per pitch length will rupture the joint when ultimate stresses are  $\sigma_t = 450 \text{ N/mm}^2$ ,  $\tau = 320 \text{ N/mm}^2$  and  $\sigma_c = 640 \text{ N/mm}^2$ . [Ans. 33.98 tonnes]
5. A thin cylindrical shell 1600 mm in diameter is made of 13.5 mm plates. The circumferential joint in a single riveted lap joint with 24 mm diameter rivets at a pitch of 60 mm. If the ultimate tensile stress in the plate is  $400 \text{ N/mm}^2$  and ultimate shearing and crushing stresses for rivets  $300 \text{ N/mm}^2$  and  $600 \text{ N/mm}^2$  respectively, calculate the efficiency of the joint. [Ans. 37.04%]
6. A single riveted double cover butt joint is used to connect two plates 60 mm thick. The rivets are 25 mm in diameter and are provided at a pitch of 10 cm. The allowable stresses in tension, shear and crushing are  $160 \text{ N/mm}^2$ ,  $90 \text{ N/mm}^2$  and  $180 \text{ N/mm}^2$  respectively, find :  
(i) Safe load per pitch length of the joint, and (ii) Efficiency of the joint. [Ans. (i) 72 kN, (ii) 28.125%]
7. If in the above problem, the single riveted butt joint is having a single cover plate instead of double cover plates, find : (i) Safe load per pitch length of the joint and (ii) Efficiency of the joint. [Ans. (i) 44.178 kN, 17.25%]
8. A single riveted double cover butt joint in a structure is used for connecting two plates 15 mm thick. The diameter of the rivets is 25 mm. The permissible stresses are  $125 \text{ N/mm}^2$  in tension  $90 \text{ N/mm}^2$  in shear and  $180 \text{ N/mm}^2$  in crushing. Calculate the necessary pitch and efficiency of the joint. [Ans. 6.1 cm, 59.01%]
9. Two plates of 15 mm thickness are connected by a double riveted double cover butt joints using 20 mm diameter rivets at a pitch of 10 cm. If the ultimate tensile stress in plate and shearing and crushing stresses in the rivets are  $450 \text{ N/mm}^2$ ,  $30 \text{ N/mm}^2$  and  $600 \text{ N/mm}^2$  respectively, find the pull per pitch length at which the joint will fail. [Ans. 36 kN]
10. A double riveted double cover butt joint is used for connecting plates 1.5 cm thick. The diameter of the rivets is 2.5 cm. The permissible stresses are  $120 \text{ N/mm}^2$  in tension,  $90 \text{ N/mm}^2$  in shear and  $180 \text{ N/mm}^2$  in crushing. Draw a neat sketch of the joint and calculate the necessary pitch and efficiency of the joint. [Ans. 10 cm, 75%]

11. Find the suitable pitch for a riveted lap joint for plates 1.2 thick if safe working stresses in tension in the plates and crushing and shearing of the rivet materials are respectively  $140 \text{ N/mm}^2$ ,  $200 \text{ N/mm}^2$  and  $90 \text{ N/mm}^2$  in the following types of joints : (i) single riveted and (ii) double riveted. Find also the efficiency of the joint in the above two cases. Take  $d = 19\sqrt{t}$ .  
[Ans. (i) 5.5 cm, 33.73% (ii) 6 cm, 61.84%]
12. Two plates 10 mm thick are joined by a single riveted lap joint. The plates are subjected to a load of 180 kN. If the permissible tensile shear and crushing stresses are  $125 \text{ N/mm}^2$ ,  $90 \text{ N/mm}^2$  and  $170 \text{ N/mm}^2$  respectively. Determine : (i) diameter of rivets, (ii) pitch of the rivet, (iii) number of rivets and (iv) efficiency of the joint. [Ans. 1.9 cm ; 4.75 cm ; 8 ; 42.97%]
13. Design a double cover butt joint to connect two plates 1.2 cm thick and 18 cm wide. The safe stresses are  $\sigma_t = 120 \text{ N/mm}^2$ ,  $\tau = 90 \text{ N/mm}^2$  and  $\sigma_c = 180 \text{ N/mm}^2$ . Also determine the efficiency of the joint. [Ans.  $d = 2.1 \text{ cm}$ ,  $n = 5$ ,  $p = 6.5 \text{ cm}$ ,  $t_1 = 0.75 \text{ cm}$  and  $\eta = 67.7\%$ ]

# 21

## Welded Joints

### 21.1. INTRODUCTION

The process of permanently joining two or more metal parts by the fusion of the edges of the metals with or without the application of pressure and a filler material, is known as welding. If the pressure is used for joining the two parts, the process is known as *forge welding* whereas if the two parts are joined without any pressure but with a separate weld metal, the process is known as *fusion welding*. The joints so formed are known as welded joints.

The heat of melt for the weld metal is generally obtained by gas welding or by electric arc welding.

### 21.2. ADVANTAGES AND DISADVANTAGES OF WELDED CONNECTIONS

The advantages and disadvantages of welded connections over riveted connection are given below :

#### Advantages

1. The welded structure are comparatively lighter than corresponding riveted structure.
2. The welded joint has greater strength as compared to the riveted joint. Hence efficiency of a welded joint is more than that of a riveted joint.
3. Addition and alternations can be easily made in the existing welding structure more easily than in riveted structure.
4. A welded structure has a better finish and appearance than a corresponding riveted member. The maintenance and painting cost for a welded structure is less than for the riveted structure.
5. Welding takes less time than riveting.
6. In welded connections the tension members are not weakened as in the riveted joints.
7. Members of such shapes, which are difficult for riveting, can be easily welded.
8. It is possible to weld any part of a structure at any point. But riveting requires enough clearance.

#### Disadvantages

1. Welding requires skilled labour and supervision.
2. As there is an uneven heating and cooling during welding, the members may get distorted or additional stresses may develop.
3. Testing a weld joint is difficult. An X-ray examination alone can enable us to study the quality of the connection.

4. Since no provision is kept for expansion or contraction in the frame, therefore, crack may develop in it.

### 21.3. TYPES OF WELDED JOINTS

The two important types of welded joints are :

1. Butt weld and
2. Fillet weld or lap joint.

**21.3.1. Butt Weld Joint.** If the edges of the two members butt (i.e., touch) against each other and the two members are joined by welding, then the joint so formed is known as butt-weld joint. Fig. 21.1 shows the isometric view of a butt-weld joint.

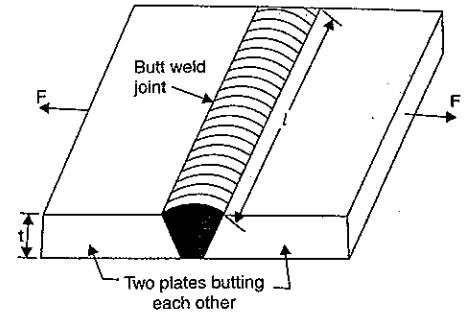

Fig. 21.1

Let  $l$  = Length of the weld. It is equal to the width of plate.

$t$  = Depth of weld. It is equal to the thickness of the plate.

$F$  = Tensile force.

$\sigma_t$  = Allowable tensile stress in the weld.

Then the tensile force is given by

$$F = \text{Tensile stress} \times \text{Area} \\ = \sigma_t \times l \times t$$

...(21.1)

Equation (21.1) is also used to calculate the strength of the butt-weld joint.

The following types of butt-weld joints are mostly used :

1. Single V-butt joint [Fig. 21.2 (a)]
2. Single U-butt joint [Fig. 21.2 (b)]
3. Double V-butt joint [Fig. 21.2 (c)]
4. Double U-butt joint [Fig. 21.2 (d)].

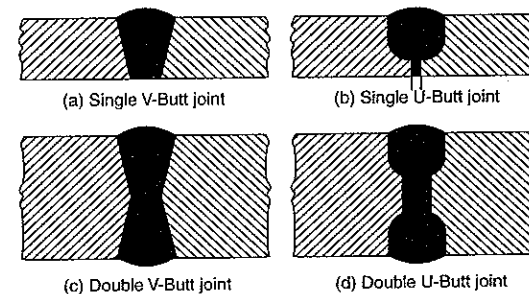

Fig. 21.2. Different types of butt-weld joints.

**21.3.2. Fillet Weld or Lap Joint.** When the two members overlap each other and they are joined by welding, then the joint so formed is known as lap joint or fillet weld joint. Fig. 21.3 (a) shows the isometric view of a fillet weld joint.

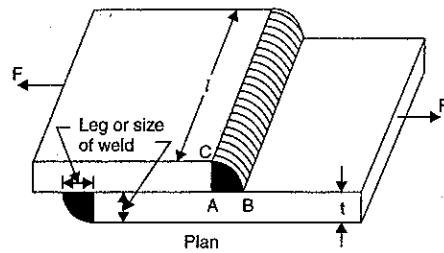

Fig. 21.3 (a)

Let  $t$  = Thickness of the plate. This is also known as the size of the weld

$l$  = Length of the weld

$\sigma_t$  = Allowable tensile stress for weld metal

$F$  = Tensile strength of double fillet lap joint.

Then throat thickness  $AD$  [See Fig. 21.3 (b)]

$$\begin{aligned}
 &= AB \sin 45^\circ \quad (\because ABC \text{ is an isosceles right angled triangle}) \\
 &= t \times \frac{1}{\sqrt{2}} \quad (\because AB = t) \\
 &= \frac{\sqrt{2} \times t}{2} = 0.707t
 \end{aligned}$$

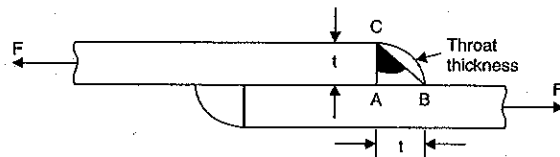

Fig. 21.3 (b)

Then tensile strength of the double fillet lap is given by,

$$\begin{aligned}
 F &= \text{Tensile stress} \times \text{Area of double fillet weld} \\
 &= \sigma_t \times 2 \times \text{length of weld} \times \text{Throat thickness} \\
 &= \sigma_t \times 2 \times l \times 0.707 \times t \quad (\because \text{Throat thickness} = 0.707t) \\
 &= 1.414 \times \sigma_t \times l \times t \quad \dots(21.2)
 \end{aligned}$$

If the fillet weld is a single fillet lap joint, then strength is given by,

$$\begin{aligned}
 F &= \sigma_t \times \text{Area of single fillet weld} \\
 &= \sigma_t \times \text{Length of weld} \times \text{Throat thickness} \\
 &= \sigma_t \times l \times 0.707t \quad (\because \text{Throat thickness} = 0.707t) \\
 &= 0.707 \times \sigma_t \times l \times t \quad \dots(21.3)
 \end{aligned}$$

The following types of fillet weld joints are mostly used :

1. Single fillet lap joint, [Fig. 21.4]
2. Double fillet lap joint, [Fig. 21.5]
3. Parallel fillet joint, [Fig. 21.6].

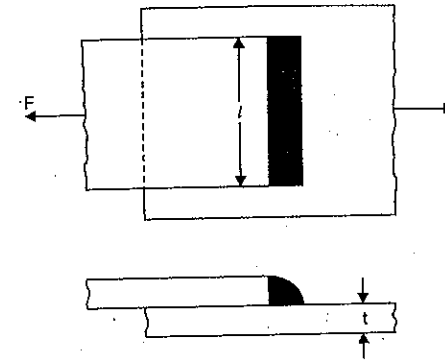

Fig. 21.4. Single fillet lap joint.

### 1. Single fillet lap joint [Fig. 21.4]

$$\begin{aligned}
 \text{Area of fillet weld} &= \text{Length of weld} \times \text{Throat thickness} \\
 &= l \times 0.707t \quad \dots(21.4)
 \end{aligned}$$

where  $t$  = Thickness of plate and  
 $l$  = Length of weld.

### 2. Double fillet lap joint [Fig. 21.5]

$$\begin{aligned}
 \text{Area of fillet weld} &= l \times \text{Throat thickness} + l \times \text{Throat thickness} \\
 &= 2l \times \text{Throat thickness} \\
 &= 2l \times 0.707t \\
 &= 1.414 \times l \times t. \quad \dots(21.5)
 \end{aligned}$$

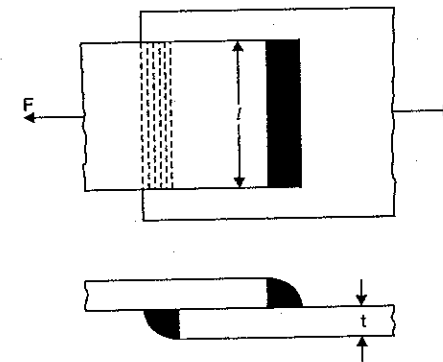

Fig. 21.5. Double fillet lap joint.

### 3. Parallel fillet weld [Fig. 21.6]

Let  $l$  = Length of parallel weld  
 $t$  = Thickness of plate.

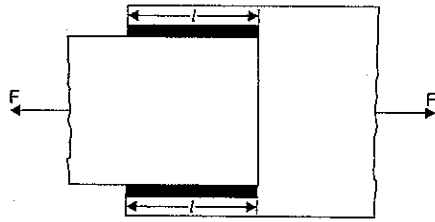

Fig. 21.6. Parallel fillet weld.

Then,  
Area of parallel fillet weld

$$\begin{aligned}
 &= l \times \text{Throat thickness} + l \times \text{Throat thickness} \\
 &= l \times 0.707t + l \times 0.707t \\
 &= 1.414 \times l \times t \quad \dots(21.6)
 \end{aligned}$$

**Notes 1.** The throat thickness of depth of weld in case of butt weld joint is equal to the thickness of plate (i.e.,  $t$ ) whereas the throat thickness for lap joint or fillet weld joint is equal to  $0.707t$ .

**2.** The single and double fillet lap joints are designed for tensile strength whereas the parallel fillet weld is designed for shear strength.

**Problem 21.1.** Two steel plates 10 cm wide and 1.25 cm thick are to be joined by double lap weld joint. Find the length of the weld if the maximum tensile stress is not to exceed  $75 \text{ N/mm}^2$  and maximum tensile load carried by the plates is 100 kN.

**Sol. Given :**

- Width of the plate,  $b = 10 \text{ cm} = 100 \text{ mm}$
- Thickness of the plate,  $t = 1.25 \text{ cm} = 12.5 \text{ mm}$
- Maximum tensile stress,  $\sigma_t = 75 \text{ N/mm}^2$
- Minimum tensile load,  $F = 100 \text{ kN} = 100000 \text{ N}$
- Let  $l =$  Length of the weld.

The tensile strength of the double fillet lap joint is given by equation (21.2).

$\therefore$  Using equation (21.2), we have

$$F = 1.414 \times \sigma_t \times l \times t$$

or  $100000 = 1.414 \times 75 \times l \times 12.5$

$$\therefore l = \frac{100000}{1.414 \times 75 \times 12.5} = 75.4 \text{ cm. Ans.}$$

**Problem 21.2.** A steel plate 10 cm wide and 1 cm thick is to be joined by parallel filler welds to another plate. The plates are subjected to a load of 50 kN. Find the length of the weld, if the maximum shear stress does not exceed  $55 \text{ N/mm}^2$ .

**Sol. Given :**

- Width of plates,  $b = 10 \text{ cm} = 100 \text{ mm}$
- Thickness of plates,  $t = 1.0 \text{ cm} = 10 \text{ mm}$
- Load,  $F = 50 \text{ kN} = 50000 \text{ N}$
- Max. shear stress,  $\tau = 55 \text{ N/mm}^2$

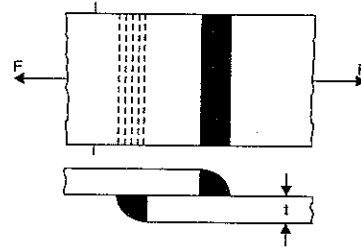

Fig. 21.7

Let  $l =$  Length of the weld.

Now area of parallel fillet weld is given by equation (21.6).

$$\begin{aligned}
 \therefore \text{Area of parallel fillet weld} \\
 &= 1.414 \times l \times t \\
 &= 1.414 \times l \times 10 \text{ mm}^2
 \end{aligned}$$

The load carried by parallel fillet weld is given by

$$\text{Load} = \text{Stress} \times \text{Area of parallel fillet weld}$$

or  $50000 = 55 \times 1.414 \times l \times 10$

$$\therefore l = \frac{50000}{55 \times 1.414 \times 14} = 64.3 \text{ mm. Ans.}$$

**Problem 21.3.** Two plates of width 12 cm and thickness 1.15 cm are welded by a single V-butt joint. If the safe stress in the weld is  $140 \text{ N/mm}^2$ , find the permissible load carried by the plates.

**Sol. Given :**

Width of plates,  $b = 12 \text{ cm} = 120 \text{ mm}$

Thickness of the plates,

$$t = 1.25 \text{ cm} = 12.5 \text{ mm}$$

Safe stress,  $\sigma_t = 140 \text{ N/mm}^2$

Let  $F =$  Permissible load carried by the plates.

In case of a butt joint, the width of the plate is equal to the length of the weld.

$$\therefore \text{Length of weld, } l = b = 120 \text{ mm}$$

Now using equation (21.1),

$$\begin{aligned}
 F &= \sigma_t \cdot l \cdot t = 140 \times 120 \times 12.5 \\
 &= 210000 \text{ N} = 210 \text{ kN. Ans.}
 \end{aligned}$$

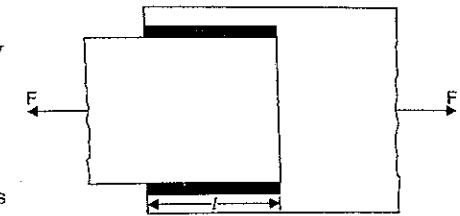

Fig. 21.8

$$(\because \text{Area} = 1.414 \times l \times 10)$$

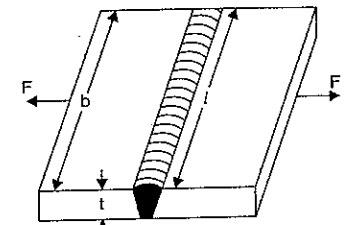

Fig. 21.9

### 21.4. ANALYSIS OF A COMPOUND WELD

Fig. 21.10 shows a combination of parallel fillet weld and a single fillet lap weld. This type of a weld is known as a compound weld. The weld AB and CD are parallel fillet weld whereas the weld BC is a single fillet lap weld.

Let  $F_1 =$  load carried by single fillet lap weld (i.e., by weld BC)

$F_2 =$  Load carried by parallel fillet weld (i.e., by welds AB and CD)

$$F = \text{Total load carried by the plates} = F_1 + F_2 \quad \dots(i)$$

$l_1 =$  Length of single fillet lap weld

$l_2 =$  Length of the parallel fillet welds

$t =$  Thickness of the plates

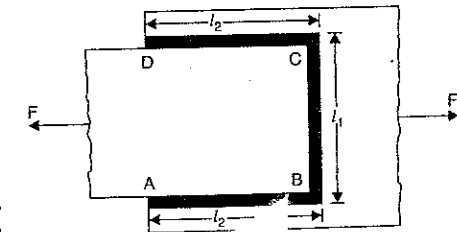

Fig. 21.10

$\sigma_t$  = Maximum tensile stress in the weld

$\tau$  = Maximum shear stress in the weld.

We know that the fillet lap weld is designed for tensile stress whereas the parallel fillet welds are designed for shear stress.

The load carried by a single fillet lap weld is given by equation (21.3).

$\therefore$  Using equation (21.3)

Load =  $0.707 \times \sigma_t \times \text{Length of weld} \times \text{Thickness of plate}$

$$\text{or } F_1 = 0.707 \times \sigma_t \times l_1 \times t \quad \dots(21.7)$$

Now the area of parallel fillet weld is given by equation (21.6) as

Area of fillet parallel weld =  $1.414 \times l_2 \times t$ .

The load carried by parallel fillet weld is given by,

Load = Area of parallel fillet weld  $\times \tau$

$$\text{or } F_2 = 1.414 \times l_2 \times t \times \tau \quad \dots(21.8)$$

Substituting equations (21.7) and (21.8) in equation (i), we get

$$F = 0.707 \times \sigma_t \times l_1 \times t + 1.414 \times l_2 \times t \times \tau \quad \dots(21.9)$$

**Problem 21.4.** A plate 10 cm wide and 1.20 cm thick is joined with another plate by a single fillet lap weld and a double parallel fillet weld as shown in Fig. 21.11. The maximum tensile and shear stresses are  $75 \text{ N/mm}^2$  and  $55 \text{ N/mm}^2$  respectively. Find the length of each parallel fillet if the joint is subjected to a total load of 90000 N.

**Sol.** Given :

Width of plate,  $b = 10 \text{ cm} = 100 \text{ mm}$

Thickness of plate,  $t = 12 \text{ mm}$

Maximum tensile stress,

$$\sigma_t = 75 \text{ N/mm}^2$$

Minimum shear stress,

$$\tau = 55 \text{ N/mm}^2$$

Length of single fillet lap weld,

$$l_1 = \text{width of plate} \\ = 100 \text{ mm.}$$

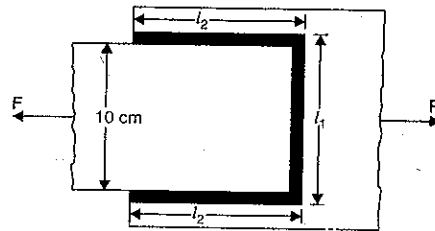

Fig. 21.11

Let  $t_2$  = Length of each parallel fillet weld

$F_1$  = Load carried by single fillet lap weld

$F_2$  = Load carried by parallel fillet weld

Total load carried by the plates,

$$F = 90000 \text{ N.}$$

The load carried by single fillet lap weld is given by equation (21.7).

$$\therefore F_1 = 0.707 \times \sigma_t \times l_1 \times t \\ = 0.707 \times 75 \times 100 \times 12 = 63630 \text{ N}$$

The load carried by double parallel fillet weld is given by equation (21.8).

$$\therefore F_2 = 1.414 \times l_2 \times t \times \tau \\ = 1.414 \times l_2 \times 12 \times 55 = 933.24 \times l_2$$

Now total load carried by the plates is given by

$$F = F_1 + F_2$$

$$\text{or } 90000 = 63630 + 933.24 \times l_2$$

$$\text{or } 90000 - 63630 = 933.24 \times l_2$$

$$\text{or } l_2 = \frac{90000 - 63630}{933.24} = 28.25 \text{ mm. Ans.}$$

## 21.5. ANALYSIS OF UNSYMMETRICAL WELDED SECTIONS WHICH ARE LOADED AXIALLY

Fig. 21.12 shows an angle section welded to a plate and carries an axial load  $F$ . Such welded sections are known as unsymmetrical welded section.

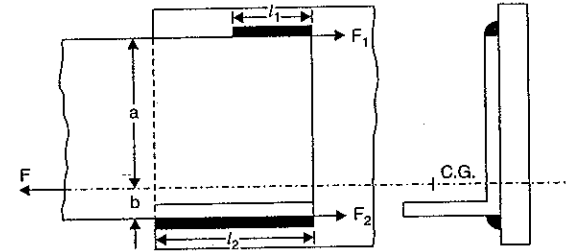

Fig. 21.12

The axial load  $F$  is applied along the axis which passes through the C.G. of the unsymmetrical section, in order to avoid the effect of eccentricity. Now the lengths of the weld  $l_1$  and  $l_2$  should be so proportioned that the sum of the resisting moments of the welds about the centre of the gravity axis is zero. Or in other words, the C.G. of the lengths of welds  $l_1$  and  $l_2$  lies on the line of action of the load  $F$ .

Let  $\tau$  = Allowable shear stress in the weld

$l_1$  = Length of weld at the top

$l_2$  = Length of weld at the bottom

$l$  = Total length of the weld =  $l_1 + l_2$

$a$  = Distance of top edge of the angle section from gravity axis

$b$  = Distance of bottom edge of the angle section from gravity axis

$F$  = Axial load on the angle

$s$  = Resistance offered by the weld per unit length

$F_1$  = Resistance of the top weld

= Resistance of weld per unit length  $\times$  Length of top weld

$$= s \times l_1$$

$F_2$  = Resistance of the bottom weld

$$= s \times l_2$$

$F$  = Axial load on the angle

$$= F_1 + F_2 \text{ (For the equilibrium of the welded section)}$$

Now the moment of the top weld about gravity axis

$$= \text{Resistance of top weld} \times \text{Distance of top weld from gravity axis}$$

$$= F_1 \times a$$

$$= s \times l_1 \times a.$$

Similarly moment of the bottom weld about gravity axis

$$= F_2 \times b = s \times l_2 \times b.$$

Since the sum of moment of the weld about the gravity axis must be zero. Hence

$$s \times l_1 \times a = s \times l_2 \times b$$

or  $l_1 \times a = l_2 \times b$  ... (i)

Now we know that total length of the weld is equal to the sum of the lengths of top weld and bottom weld.

$$\therefore l = l_1 + l_2 \quad \dots (ii)$$

$$= l_1 + \frac{l_1 \times a}{b} \quad \left( \because \text{From equation (i), } l_2 = \frac{l_1 \times a}{b} \right)$$

$$= \frac{b l_1 + l_1 \times a}{b} = \frac{l_1 (a + b)}{b}$$

$$\therefore l_1 = \frac{b \times l}{a + b} \quad \dots (21.10)$$

Substituting the value of  $l_1$  in equation (ii), we get

$$l = \frac{b \times l}{a + b} + l_2 = \frac{b \times l + l_2 (a + b)}{(a + b)}$$

$$\text{or } l(a + b) = b \times l + l_2(a + b)$$

$$\text{or } l \times a + l \times b = b \times l + l_2(a + b)$$

$$\text{or } l \times a + l \times b - b \times l = l_2(a + b)$$

$$\text{or } l \times a = l_2(a + b)$$

$$\text{or } l_2 = \frac{a \times l}{(a + b)} \quad \dots (21.11)$$

From equations (21.10) and (21.11), the length of the top weld and length of bottom weld can be calculated. Then the resistance of the top weld (i.e.,  $F_1$ ) and resistance of bottom weld (i.e.,  $F_2$ ) can be easily obtained as given below :

$$F_1 = s \times l_1$$

$$= s \times \frac{b \times l}{(a + b)} \quad \left( \because \text{From equation (21.10), } l_1 = \frac{b \times l}{(a + b)} \right)$$

$$= \frac{b \times F}{a + b} \quad (\because s \times l = \text{Total resistance} = F) \quad \dots (21.12)$$

$$\text{Similarly } F_2 = \frac{a \times F}{(a + b)} \quad \dots (21.13)$$

#### Axial load in terms of shear stress

The axial load ( $F$ ) in terms of shear stress is given by :

Axial load = Shear stress  $\times$  Area of weld

$$\text{i.e., } F = \tau \times \text{Area of weld}$$

But area of weld = (Total length of weld)  $\times$  Throat thickness

$$= (l_1 + l_2) \times 0.707 \times t \quad (\because \text{Throat thickness} = 0.707 \times t)$$

where  $t$  = Size of weld or thickness of plate

$$\therefore F = \tau \times (l_1 + l_2) \times 0.707 \times t \quad \dots (21.14)$$

**Problem 21.5.** A 200 mm  $\times$  150 mm  $\times$  10 mm angle, carrying a load of 200 kN, is to be welded to a steel plate by fillet welds as shown in Fig. 21.13. Find the lengths of the weld at the

top and bottom if the allowable shear stress in the weld is 102.5 N/mm<sup>2</sup>. The distances between the neutral axis and the edges of the angle section are 144.7 mm and 55.3 mm respectively.

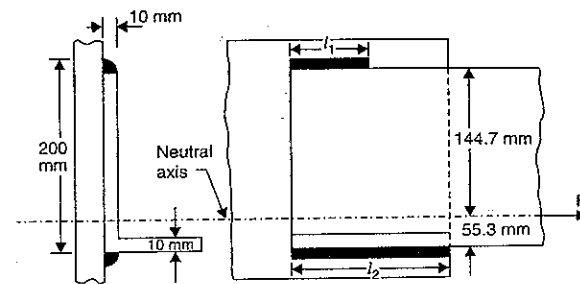

Fig. 21.13

**Sol. Given :**

Dimension of angle = 200 mm  $\times$  150 mm  $\times$  10 mm

$\therefore$  Thickness of angle = 10 mm

$\therefore$  Size of weld,  $t = 10$  mm

Axial load,  $F = 200$  kN = 200000 N

Allowable shear stress,  $\tau = 102.5$  N/mm<sup>2</sup>

Distance of the top edge of the angle section from neutral axis,  
 $a = 144.7$  mm

Distance of the bottom edge of the angle section from neutral axis,  
 $b = 55.3$  mm

Let  $l_1$  = Length of weld at the top

$l_2$  = Length of the weld at the bottom

$l$  = Total length of weld =  $l_1 + l_2$

Now using equation (21.14), we have

$$F = \tau \times (l_1 + l_2) \times 0.707 \times t$$

$$\text{or } 200000 = 102.5 \times (l_1 + l_2) \times 0.707 \times 10$$

$$\text{or } (l_1 + l_2) = \frac{200000}{102.5 \times 0.707 \times 10} = 276 \text{ mm} \quad \dots (i)$$

$$\text{or } l = 276 \text{ mm} \quad (\because l = l_1 + l_2)$$

Now using equation (21.10),

$$l_1 = \frac{b \times l}{a + b} = \frac{55.3 \times 276}{(144.7 + 55.3)} = 76.3 \text{ mm. Ans.}$$

Substituting the value of  $l_1$  in equation (i), we get

$$76.3 + l_2 = 276$$

$$\text{or } l_2 = 276 - 76.3 = 199.7 \text{ mm. Ans.}$$

**Problem 21.6.** A 90 mm  $\times$  50 mm  $\times$  8 mm angle carrying a load of 125 kN is to be connected to a gusset plate by welding. If the size of the weld is 6 mm and maximum allowable shear stress in the weld is 102.5 N/mm<sup>2</sup>, find the lengths of the weld at the top and bottom. The

distances between the neutral axis and the bottom and the top edges of the angle sections are 28.7 mm and 61.3 mm respectively.

**Sol. Given :**

Dimensions of the angle = 90 mm × 50 mm × 8 mm

Axial load,  $F = 125 \text{ kN} = 125000 \text{ N}$

Size of weld,  $t^* = 6 \text{ mm}$

Maximum allowable shear stress,  $\tau = 102.5 \text{ N/mm}^2$

Distance between the neutral axis and bottom edge,

$$b = 28.7 \text{ mm}$$

Distance between the neutral axis and top edge,

$$a = 61.3 \text{ mm}$$

Let  $l_1 =$  Length of weld at the top,

$l_2 =$  Length of weld at the bottom.

$l =$  Total length of weld =  $l_1 + l_2$

Now using equation (21.1), we have

$$F = \tau \times (l_1 + l_2) \times 0.707 \times t$$

where  $t =$  size of the weld

$$\therefore 125000 = 102.5 \times (l_1 + l_2) \times 0.707 \times 6$$

$$\therefore l_1 + l_2 = \frac{125000}{102.5 \times 0.707 \times 6}$$

$$= 287.5 \text{ mm} \quad \dots(i)$$

or

$$l = 287.5 \text{ mm} \quad (\because l = l_1 + l_2)$$

Now using equation (21.10),

$$l_1 = \frac{b \times l}{(a + b)} = \frac{28.7 \times 287.5}{(28.7 + 61.3)} = 91.68 \text{ mm. Ans.}$$

Substituting the value of  $l_1$  in equation (i), we get

$$91.68 + l_2 = 287.5$$

$$\therefore l_2 = 287.5 - 91.68 = 195.82 \text{ mm. Ans.}$$

**Problem 21.7.** A 150 mm × 115 mm × 8 mm angle carrying a tensile force of 200 kN is to be connected to a gusset plate by 6 mm fillet welds at the extremities of the longer leg, the shorter leg being outstanding. Find lengths of welds if the C.G. of angle is 44.6 mm from the top of the shorter leg. Take permissible shear stress in the welds as 102.5 N/mm<sup>2</sup>.

(AMIE, Winter 1983)

**Sol. Given :**

Dimensions of angle = 150 mm × 115 mm × 8 mm

Load carried by angle,  $F = 200 \text{ kN} = 200 \times 1000 = 200000 \text{ N}$

Size of the weld,  $t = 6 \text{ mm}$

The distance of C.G. of the angle from the top of shorter leg,

$$b = 44.6 \text{ mm}$$

$\therefore$  Distance of the C.G. of the angle from the top edge of the angle i.e.,

$$a = 150 - 44.6 = 105.4 \text{ mm.}$$

\*Here thickness of the angle is 8 mm. But the size of weld is 6 mm. This means the thickness of the weld is 6 mm. Hence  $t = 6 \text{ mm}$ .

Shear stress in weld,  $\tau = 102.5 \text{ N/mm}^2$

Let  $l_1 =$  Length of top weld,

$l_2 =$  Length of bottom weld.

$l =$  Total length of weld.

The angle is welded to the plate as shown in Fig. 21.14.

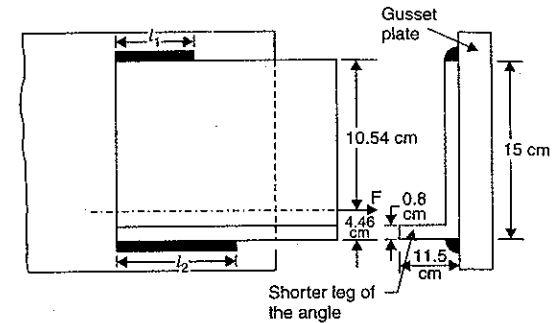

Fig. 21.14

Now using the equation (21.14), we have

$$F = \tau \times (l_1 + l_2) \times 0.707 \times t$$

or

$$200000 = 102.5 \times (l_1 + l_2) \times 0.707 \times 6$$

$\therefore$

$$(l_1 + l_2) = \frac{200000}{102.5 \times 0.707 \times 6}$$

$$= 459.97 \text{ mm say } 460 \text{ mm} \quad \dots(i)$$

or

$$l = 460 \text{ mm} \quad (\because l_1 + l_2 = l)$$

Using equation (21.10), we get

$$l_1 = \frac{b \times l}{a + b}$$

$$= \frac{44.6 \times 460}{(105.4 + 44.6)} = \frac{44.6 \times 460}{150}$$

$$= 136.7 \text{ mm. Ans.}$$

Substituting this value of  $l_1$  in equation (i), we get

$$136.7 + l_2 = 460$$

$\therefore$

$$l_2 = 460 - 136.7 = 323.3 \text{ cm. Ans.}$$

**Problem 21.8.** Two angles 80 mm × 80 mm × 8 mm carrying a load of 220 kN are to be connected to a gusset plate on either side of the plate by 6 mm fillet welds as shown in Fig. 21.15. The permissible shear stress in the weld is 102.5 N/mm<sup>2</sup>. The distances between the neutral axis and top and bottom edges of the angle sections are 57.3 mm and 22.7 mm respectively. Find the lengths of the weld at the top and bottom.

**Sol. Given :**

Dimensions of two angles = 80 mm × 80 mm × 8 mm

Axial load,  $F = 220 \text{ kN} = 220 \times 1000 = 220000 \text{ N}$

Size of weld,  $t = 6 \text{ mm}$   
 Permissible shear stress,  $\tau = 102.5 \text{ N/mm}^2$   
 Distance between neutral axis and top edge of the angle,  
 $a = 57.3 \text{ mm}$   
 Distance between neutral axis and bottom edge of the angle,  
 $b = 2.27 \text{ cm} = 22.7 \text{ mm}$

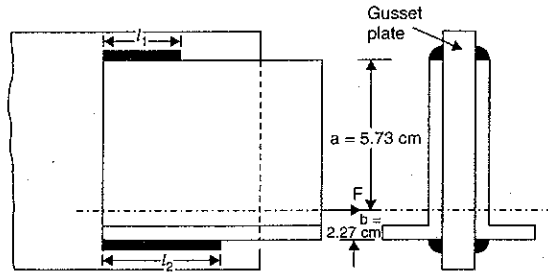

Fig. 21.15

Let  $l_1$  = Length of top weld on one angle  
 $l_2$  = Length of bottom weld on one angle  
 $l$  = Total length of weld for two angles  
 $= (l_1 + l_2) \times 2$  ( $\because$  There are two angles on either side of the plate)  
 $= 2(l_1 + l_2)$ .

The two angles are welded to the gusset plate as shown in Fig. 21.15.

Now using equation (21.14), we have

Axial load  $= \tau \times \text{Total area of weld}$   
 or  $F = \tau \times \text{Total length of weld} \times \text{Throat thickness}$   
 $= \tau \times 2(l_1 + l_2) \times 0.707 \times t$  ( $\because$  Throat thickness  $= 0.707 t$ )  
 or  $220000 = 102.5 \times 2(l_1 + l_2) \times 0.707 \times 6.0$  ( $\because t = 6$ )

$\therefore (l_1 + l_2) = \frac{220000}{102.5 \times 2 \times 0.707 \times 6}$   
 $= 253.0 \text{ mm} \dots(i)$

Now using equation (21.10), we get

$l_1 = \frac{b \times (l_1 + l_2)}{a + b} = \frac{22.7 \times 253}{57.3 + 22.7} = \frac{22.7 \times 253}{80} = 71.8 \text{ mm. Ans.}$

Substituting the value of  $l_1$  in equation (i), we get

$71.8 + l_2 = 253$   
 $\therefore l_2 = 253 - 71.8 = 181.2 \text{ mm. Ans.}$

**Problem 21.9.** A welded lap joint is provided to connect two tie bars  $15 \text{ cm} \times 1 \text{ cm}$  as shown in Fig. 21.16.

The working stress in tie bars is  $150 \text{ N/mm}^2$ . Investigate the design if the size of the fillet weld is  $8 \text{ mm}$ . The safe stress for the weld may be taken as  $102 \text{ N/mm}^2$ .

**Sol. Given :**  
 Nature of welded joint = Lap joint  
 Size of tie bar =  $15 \text{ cm} \times 1 \text{ cm}$   
 $\therefore$  Area of tie bar,  $A = 15 \times 1$   
 $= 15 \text{ cm}^2$   
 $= 1500 \text{ mm}^2$

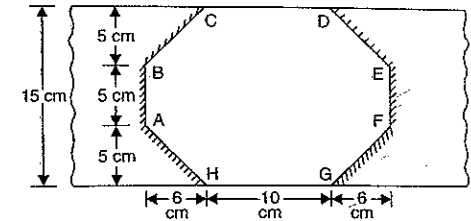

Fig. 21.16

Working stress in the tie bar  
 $= 150 \text{ N/mm}^2$   
 $\therefore$  Maximum load, the tie bar can resist  
 $= \text{Working stress in tie bar} \times \text{Area of bar}$   
 $= 150 \times 1500 = 225000 \text{ N}$

Size of fillet weld,  $t = 8 \text{ mm}$   
 $\therefore$  Throat thickness of weld  
 $= 0.707 \times t = 0.707 \times 8 \text{ mm}$

Safe stress in the weld =  $102 \text{ N/mm}^2$   
 Total length of the weld = Length AB + Length BC + Length DE  
 $+ \text{Length EF} + \text{Length FG}$

But length AB = Length EF,  
 and length DE = Length BC = Length FG = Length AH  
 $\therefore$  Total length of the weld  
 $= 2(\text{Length AB}) + 4(\text{Length AH})$   
 $= 2 \times 5 + 4(\sqrt{5^2 + 6^2})$  ( $\because AH = \sqrt{5^2 + 6^2}$ )  
 $= 10 + 4\sqrt{61} = 41.24 \text{ cm} = 412.4 \text{ mm}$   
 $\therefore$  Strength of weld = Safe stress in weld  $\times$  Area of weld  
 $= 102 \times (\text{Total length of weld} \times \text{Throat thickness of weld})$   
 $= 102 \times (412.4 \times 0.707 \times 8) = 237918.5 \text{ N.}$

Since the strength of the weld is greater than the maximum load, the tie bar can resist. Hence the joint is safe. **Ans.**

**Problem 21.10.** A welded lap joint is provided to connect two tie bars  $12 \text{ cm} \times 1 \text{ cm}$  as shown in Fig. 21.17.

The working stress in the tie bar is  $150 \text{ N/mm}^2$ . Investigate the design, if the size of the fillet is  $8 \text{ mm}$ . The safe stress for the end fillet weld and diagonal fillet weld may be taken as  $102.5 \text{ N/mm}^2$  and  $80 \text{ N/mm}^2$  respectively.

**Sol. Given :**  
 Nature of joint = Lap welded joint  
 Size of tie bar =  $12 \text{ cm} \times 1 \text{ cm}$   
 $\therefore$  Area of tie bar =  $12 \times 1 = 12 \text{ cm}^2$   
 $= 1200 \text{ mm}^2$   
 Working stress in tie bar  
 $= 150 \text{ N/mm}^2$

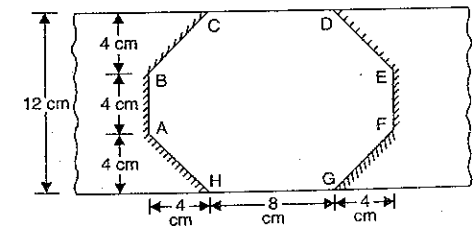

Fig. 21.17



$$\begin{aligned} \therefore \text{Maximum load, the tie bar can resist} \\ &= \text{Working stress in tie bar} \times \text{Area of bar} \\ &= 150 \times 1200 = 180000 \text{ N} \end{aligned}$$

Size of the fillet weld,  $t = 8 \text{ mm}$

$$\therefore \text{Throat thickness of weld} = 0.707 \times t = 0.707 \times 8 \text{ mm}$$

$$\text{Safe stress in the end fillet weld} = 102.5 \text{ N/mm}^2$$

$$\text{Safe stress in the diagonal fillet weld} = 80 \text{ N/mm}^2$$

$$\begin{aligned} \text{Total length of end fillet welds} \\ &= AB + EF \\ &= 5 + 5 = 10 \text{ cm} = 100 \text{ mm} \end{aligned}$$

$$\begin{aligned} \text{Total length of diagonal fillet welds} \\ &= BC + DE + FG + AH \\ &= 4 \times AH = 4 \times \sqrt{4^2 + 4^2} = 4 \times 4 \times \sqrt{2} \text{ cm} \\ &= 16 \times \sqrt{2} \text{ cm} = 160 \times \sqrt{2} \text{ mm} \end{aligned}$$

$$\text{But strength of weld} = \text{Safe stress in weld} \times \text{Area of weld}$$

$$\begin{aligned} \therefore \text{Strength of end fillet weld} \\ &= \text{Safe stress in end fillet weld} \times \text{Area of end fillet weld} \\ &= 102.5 \times (\text{Total length of end fillet welds} \times \text{Throat thickness}) \\ &= 102.5 \times (100 \times 0.707 \times 8) = 57974 \text{ N} \end{aligned}$$

$$\begin{aligned} \text{Similarly strength of the diagonal fillet welds} \\ &= \text{Safe stress in the diagonal fillet weld} \\ &\quad \times \text{Area of diagonal fillet welds} \\ &= 80 \times (\text{Total length of diagonal fillet welds} \times \text{Throat thickness}) \\ &= 80 \times (160 \times \sqrt{2} \times 0.707 \times 8) = 102400 \text{ N} \end{aligned}$$

$$\begin{aligned} \therefore \text{Total strength of weld} \\ &= \text{Strength of end fillet welds} \\ &\quad + \text{Strength of the diagonal fillet welds} \\ &= 57974 + 102400 = 160374 \text{ N} \end{aligned}$$

Since the strength of the weld is less than the maximum load the tie bar can resist. Hence the joint is not safe. **Ans.**

### HIGHLIGHTS

1. Welding is a process of joining permanently two or more metal parts by the fusion of the edges of the metals with or without the application of the pressure and a fillet material.
2. The joint formed by welding is known as welded joint.
3. The welded joint may be a butt weld joint or a fillet weld joint (i.e., lap joint).
4. If the edges of the two members butt (i.e., touch) against each other and the two members are joined by welding, then the joint so formed is known as butt-weld joint.
5. The depth of weld in case of a butt weld is equal to the thickness of the plate.
6. The butt-weld joint may be : (i) Single V-butt joint, (ii) Single U-butt joint, (iii) Double V-butt joint, and (iv) Double U-butt joint.

7. The strength of a single V-butt weld is given by

$$F = \sigma_t \times l \times t$$

where  $\sigma_t$  = Allowable tensile stress in the weld,

$l$  = Length of the weld, and

$t$  = Depth of weld or thickness of the plate.

8. When the two members overlap each other and they are joined by welding, then the joint so formed is known as lap joint or fillet weld joint.

9. The strength of a single lap weld joint is given by

$$P = \sigma_t \times l \times 0.707 \times t$$

where  $\sigma_t$  = Allowable tensile stress,

$l$  = Length of weld,

$t$  = Size of the weld.

10. The strength of a double lap weld joint is given by

$$F = \sigma_t \times l \times 1.414 \times t.$$

11. The throat thickness of a fillet weld is given by

$$\text{Throat thickness} = 0.707 \times t$$

where  $t$  = Size of the weld.

12. The fillet weld joint may be : (i) Single fillet lap joint, (ii) Double fillet lap joint, and (iii) Parallel fillet joint.

13. The area of fillet weld is given by,

$$A = l \times 0.707 t \quad \dots \text{For a single fillet lap joint}$$

$$= 2 \times l \times 0.707 t \quad \dots \text{For a double fillet lap joint}$$

$$= l \times 0.707 t \quad \dots \text{For a parallel fillet weld.}$$

where  $l$  = Total length of weld

$t$  = Size of the weld.

14. The throat thickness in case of a butt-weld joint is equal to the thickness of the plate whereas in case of fillet weld or lap weld the throat thickness is equal to  $0.707t$ , where  $t$  = Size of weld.

15. The single and double fillet lap joints are designed for tensile strength whereas the parallel fillet weld is designed for shear strength.

16. A combination of a parallel fillet weld and a fillet lap weld is known as compound weld.

17. The strength of a parallel fillet weld is given by

$$F = \tau \times l \times 0.707 \times t$$

where  $l$  = Total length of parallel weld,

$\tau$  = Allowable shear stress in the weld, and

$t$  = Size of the weld.

18. An angle section welded to a plate is an example of unsymmetrical welded sections.

19. The lengths of the welds at the top and bottom of an unsymmetrical welded sections should be so proportioned that the sum of the resisting moments of the welds about the centre of the gravity axis is zero.

20. The lengths of welds at the top and bottom of an unsymmetrical welded sections which are loaded axially are given by

$$l_1 = \frac{b \times l}{a + b} \quad \text{and} \quad l_2 = \frac{a \times l}{a + a}$$

where  $l_1$  = Length of weld at the top,

$l_2$  = Length of weld at the bottom,

$l$  = Total length of the weld =  $l_1 + l_2$

$\alpha$  = Distance of the top edge of the angle section from gravity axis  
 $b$  = Distance of the bottom edge of the angle section from gravity axis or neutral axis.

21. The axial load on the unsymmetrical welded section at the neutral axis is given by  

$$F = \tau \times (l_1 + l_2) \times 0.707t.$$

**EXERCISE 21**

**(A) Theoretical Questions**

- Define the terms : Welding, welded joints, forge welding and fusion welding.
- Explain the advantages and disadvantages of a welded joint.  
 (AMIE, Winter 1983 and Summer 1985)
- Name the two important types of a welded joint. Find an expression for the strength of a single V-butt weld joint.
- With neat sketches, give the important types of butt-weld joint.
- Define a fillet-weld joint and a butt joint. What are the different type of fillet-weld joint ?
- Prove that the strength of a single lap weld joint is given by

$$F = \sigma_t \times t \times 0.707 l$$

where  $\sigma_t$  = Allowable tensile stress in the weld,  
 $l$  = Length of weld, and  
 $t$  = Size of the weld.

- Define a compound weld. How will you find the strength of a compound weld consisting of parallel fillet weld and a single lap weld.
- What do you mean by unsymmetrical welded section ? How will you determine the lengths of welds at the top and bottom of an unsymmetrical welded section, which is loaded axially ?
- Prove that the lengths of welds at the top and bottom of an unsymmetrical welded section which is loaded axially, are given by

$$l_1 = \frac{b \times l}{a + b} \text{ and } l_2 = \frac{a \times l}{a + b}$$

where  $l_1$  = Length of the weld at the top,  
 $l_2$  = Length of the weld at the bottom,  
 $l$  = Total length of the weld =  $l_1 + l_2$   
 $a$  = Distance of the top edge of the angle section from gravity axis or neutral axis, and  
 $b$  = Distance of the bottom edge of the angle section from neutral axis.

**(B) Numerical Problems**

- Two steel plates 12 cm wide and 1.30 cm thick are to be joined by double lap weld point. Find the length of the weld if the maximum tensile stress is not to exceed 72 N/mm<sup>2</sup> and maximum tensile load carried by the plate is 110 kN. [Ans. 8.55 cm]
- A steel plate 10 cm wide and 1.25 cm thick is to be joined by parallel fillet welds to another plate. The plates are subjected to a load of 60 kN. Find the length of the weld if the maximum shear stress does not exceed 56 N/mm<sup>2</sup>. [Ans. 6.06 cm]
- Two plates of width 15 cm and thickness 1.25 cm are welded by a single V-butt joint. If the safe stress in the weld is 135 N/mm<sup>2</sup>, find the permissible load carried by the plates. [Ans. 25312.5 N]
- A welded lap joint is provided to connect two tie bars 15 cm × 1 cm as shown in Fig. 21.18. The working stress in the tie bar is 150 N/mm<sup>2</sup>. Investigate the design if the size of the fillet weld is 8 mm. The safe stress for the weld may be taken as 102.5 N/mm<sup>2</sup>. [Ans. Joint is safe]

- If in the above problem, the safe stress for the end fillet weld is 102.5 N/mm<sup>2</sup> whereas the safe stress for the diagonal fillet weld is 75 N/mm<sup>2</sup>, investigate the design. The other dimensions of the joint are the same as given in Fig. 21.18. [Ans. Joint is not safe]

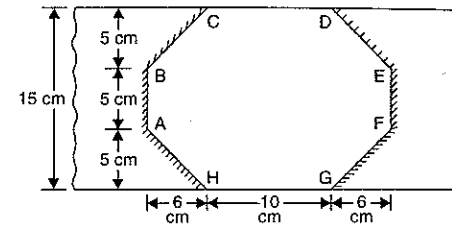

Fig. 21.18

- A plate 10 cm wide and 1.15 cm thick is joined with another plate by a single fillet lap weld and a double parallel fillet welds as shown in Fig. 21.19. The maximum tensile and shear stresses are 75 N/mm<sup>2</sup> and 55 N/mm<sup>2</sup> respectively. Find the length of each parallel fillet if the joint is subjected to a total load of 80 kN. [Ans. 2.12 cm]

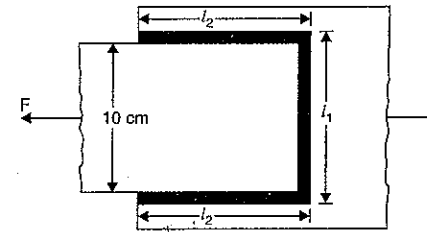

Fig. 21.19

- A 200 mm × 150 mm × 10 mm angle carrying a load of 250 kN, is to be welded to a steel plate by fillet welds as shown in Fig. 21.20. Find the length of the weld at the top and bottom if the allowable shear stress in the weld is 102.5 N/mm<sup>2</sup>. The distance between the neutral axis and the edges of the angle section are 144.7 mm and 55.3 mm respectively. [Ans.  $l_1 = 9.54$  cm and  $l_2 = 24.96$  cm]

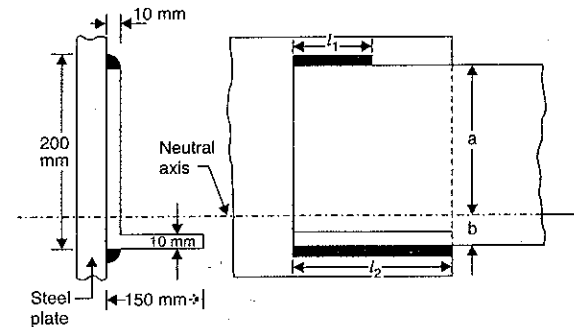

Fig. 21.20

8. A 80 mm × 80 mm × 8 mm angle carrying a load of 100 kN is to be connected to a gusset plate by welding. If the size of the weld is 6 mm and maximum allowable shear stress in the weld is 102.5 N/mm<sup>2</sup>, find the lengths of the weld at the top and bottom. The distances between the neutral axis and bottom and top edges of the angle sections are 2.27 cm and 5.73 cm respectively. [Ans.  $l_1 = 6.52$  cm,  $l_2 = 16.47$  cm]
9. A 150 mm × 115 mm × 8 mm angle carrying a tensile force of 150 kN is to be connected to a gusset plate by 6 mm fillet welds at the extremities of the longer leg, the shorter leg being outstanding. Find lengths of welds if the C.G. of the angle is 4.46 cm from the top of the shorter leg. Take permissible shear stress in the welds as 102.5 N/mm<sup>2</sup>. [Ans.  $l_1 = 10.26$  cm,  $l_2 = 24.14$  cm]

# 22

## Rotating Discs and Cylinders

### 22.1. INTRODUCTION

The stress developed due to rotation in a thin cylinder has already been derived in article 17.12 of chapter 17. In that article it has been assumed that hoop stress (or circumferential stress) is uniform in thin cylinder and is given by

$$\sigma = \rho \times \omega^2 \times r^2 \text{ or } \rho \times v^2$$

where  $\omega$  = Angular speed of rotation of thin cylinder  
 $r$  = Mean radius of cylinder  
 $\rho$  = Density of material of the cylinder and  
 $v$  = Tangential velocity of cylinder =  $\omega \times r$   
 $\sigma$  = Hoop stress in the thin cylinder.

This chapter deals with the study of stresses developed due to rotation in circular discs and cylinders. The machine members of the rotating type and bodies like circular discs, cylinders, flywheels etc. invariably rotate at high speeds. Due to rotation, these members are subjected to centrifugal forces. The stresses are set up in the material of these members due to centrifugal forces.

Also in case of thin disc, the stress in axial direction is zero. But in case of thick disc (or long cylinder) the stress in axial direction (*i.e.*, longitudinal direction) will not be zero.

### 22.2. EXPRESSION FOR STRESSES IN A ROTATING THIN DISC

In case of thin disc, only two stresses namely circumferential and radial stresses are existing.

A thin disc of inner radius  $r_1$  and outer radius  $r_2$  rotating about its axis is shown in Fig. 22.1.

Consider an element ABCD of the disc at a radius ' $r$ ' of radial width  $dr$  and thickness ' $t$ '. Let the element subtends an angle  $d\theta$  at the centre.

Let  $\sigma_r$  = Radial stress on the face AB,  
 $\sigma_r + d\sigma_r$  = Radial stress on the face CD,  
 $\sigma_c$  = Circumferential stress on faces BC and AD.

The forces due to these stresses along with centrifugal force acting on the element are shown on the enlarged view of the element.

Now consider the equilibrium of the element ABCD of radius ' $r$ ' radial width ' $dr$ ' and thickness ' $t$ ' subtending an angle  $d\theta$  at the centre as shown in Fig. 22.1.

The forces acting on the element are :

- (i) Radial force on face AB and equal to  $\sigma_r \times r \, d\theta \times t$ ,
- (ii) Radial force on face CD and equal to  $(\sigma_r + d\sigma_r)(r + dr) \times d\theta \times t$ ,
- (iii) Circumferential force on face BC =  $\sigma_c \times dr \times t$
- (iv) Circumferential force on face AD =  $\sigma_c \times dr \times t$ .
- (v) Centrifugal force =  $m \times \omega^2 \times r$  where

$$m = \text{mass of element} = \rho \times \text{volume of element} \\ = \rho \times (r \times d\theta \times dr \times t)$$

$$\therefore \text{Centrifugal force} = (\rho \times r \times d\theta \times dr \times t) \times \omega^2 \times r \\ = \rho r^2 \omega^2 d\theta dr \times t$$

The forces in circumferential direction will be equal and opposite.

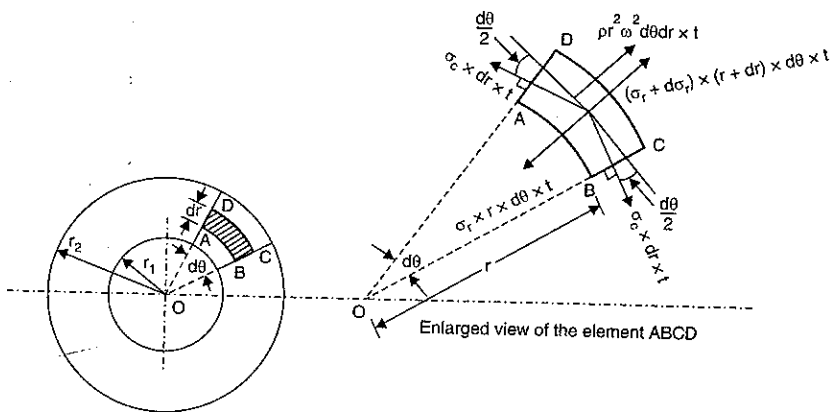

Fig. 22.1

Resolving the force in radial direction, we get

$$\sigma_r \times r \, d\theta \times t + 2\sigma_c \times dr \times t \times \sin \frac{d\theta}{2} \\ = (\sigma_r + d\sigma_r)(r + dr) \, d\theta \times t + \text{centrifugal force}$$

where centrifugal force =  $m \times \omega^2 \times r$  where  $m = \text{mass of element}$

$$= \rho \times \text{volume of element} \\ = \rho \times (rd\theta \times dr \times t) \\ = (\rho \times rd\theta \times dr \times t) \times \omega^2 \times r \\ = \rho r^2 \times \omega^2 \times d\theta \times dr \times t$$

and  $\sin \frac{d\theta}{2} \approx \frac{d\theta}{2}$  as  $d\theta$  is very small

Hence the above equation becomes as

$$\sigma_r \times rd\theta \times t + 2\sigma_c \times dr \times t \times \frac{d\theta}{2} = (\sigma_r + d\sigma_r)(r + dr) \, d\theta \times t + \rho r^2 \omega^2 \times d\theta \times dr \times t$$

Cancelling  $d\theta \times t$  to both sides, we get

$$\sigma_r \times r + 2\sigma_c \times dr \times \frac{1}{2} = (\sigma_r + d\sigma_r)(r + dr) + \rho r^2 \omega^2 \times dr$$

or  $\sigma_r \times r + \sigma_c \times dr = [\sigma_r \times r + \sigma_r \times dr + rd\sigma_r + (d\sigma_r) \times dr] + \rho r^2 \omega^2 \times dr$

or  $\sigma_c \times dr = \sigma_r \times dr + r \, d\sigma_r + \rho r^2 \omega^2 \times dr$

[Neglecting the product of two small quantities i.e.,  $(d\sigma_r) \times dr$ ]

Dividing by  $dr$  to both sides, we get

$$\sigma_c = \sigma_r + r \frac{d\sigma_r}{dr} + \rho r^2 \omega^2$$

or  $(\sigma_c - \sigma_r) = r \frac{d\sigma_r}{dr} + \rho r^2 \omega^2$  ... (i)

There are two unknowns in equation (i). They are  $\sigma_c$  and  $\sigma_r$ . To find their values, we require one more equation. The second equation is obtained from stress strain relationship. Hence first find circumferential and radial strain.

When the disc is rotating at high speed, let the radius  $r$  becomes  $(r + u)$  and  $dr$  becomes  $(dr + du)$ .

$\therefore$  Circumferential strain,

$$e_c = \frac{\text{Final circumference} - \text{Initial circumference}}{\text{Initial circumference}} \\ = \frac{2\pi(r + u) - 2\pi r}{2\pi r} = \frac{u}{r}$$

and radial strain,

$$e_r = \frac{\text{Final radial width} - \text{Initial radial width}}{\text{Initial radial width}} \\ = \frac{(dr + du) - (dr)}{dr} = \frac{du}{dr}$$

The radial and circumferential strains in terms of stresses are also given by,

$$e_c = \frac{\sigma_c}{E} - \frac{\mu\sigma_r}{E}$$

and

$$e_r = \frac{\sigma_r}{E} - \frac{\mu\sigma_c}{E}$$

Equating the two values of  $e_c$  and  $e_r$ , we get

Circumferential strain,  $e_c = \frac{\sigma_c}{E} - \frac{\mu\sigma_r}{E} = \frac{u}{r}$  ... (ii)

and radial strain,

$$e_r = \frac{\sigma_r}{E} - \frac{\mu\sigma_c}{E} = \frac{du}{dr}$$
 ... (iii)

In equations (ii) and (iii),  $u$  is the increase in radius  $r$  due to rotation and  $du$  is the increase in radial thickness  $dr$ . These two values  $u$  and  $du$  are unknowns. They can be eliminated from equations (ii) and (iii) as given below :

From equation (ii), we have

$$u = \frac{r}{E} (\sigma_c - \mu\sigma_r)$$

or

$$E \times u = r(\sigma_c - \mu\sigma_r)$$

Differentiating the above equation w.r.t.  $r$ , we get

$$E \frac{du}{dr} = (\sigma_c - \mu\sigma_r) + r \left( \frac{d\sigma_c}{dr} - \mu \frac{d\sigma_r}{dr} \right) \quad \dots(iv)$$

But from equation (iii), we have

$$\frac{du}{dr} = \frac{\sigma_r}{E} - \frac{\mu\sigma_c}{E}$$

$$E \frac{du}{dr} = \sigma_r - \mu\sigma_c \quad \dots(v)$$

Equating the two values of  $E \frac{du}{dr}$  given by equations (iv) and (v), we get

$$(\sigma_c - \mu\sigma_r) + r \left( \frac{d\sigma_c}{dr} - \mu \frac{d\sigma_r}{dr} \right) = \sigma_r - \mu\sigma_c$$

$$(\sigma_c - \mu\sigma_r) + r \left( \frac{d\sigma_c}{dr} - \mu \frac{d\sigma_r}{dr} \right) - \sigma_r + \mu\sigma_c = 0$$

$$\sigma_c(1 + \mu) - \sigma_r(1 + \mu) + r \left( \frac{d\sigma_c}{dr} - \mu \frac{d\sigma_r}{dr} \right) = 0$$

$$(\sigma_c - \sigma_r)(1 + \mu) + r \left( \frac{d\sigma_c}{dr} - \mu \frac{d\sigma_r}{dr} \right) = 0 \quad \dots(vi)$$

Substituting the value of  $(\sigma_c - \sigma_r)$  from equation (i), into above equation (vi), we get

$$\left[ \frac{r d\sigma_r}{dr} + \rho r^2 \times \omega^2 \right] [1 + \mu] + r \left( \frac{d\sigma_c}{dr} - \mu \frac{d\sigma_r}{dr} \right) = 0$$

$$\left[ r \frac{d\sigma_r}{dr} + \rho r^2 \times \omega^2 \right] (1 + \mu) + r \frac{d\sigma_c}{dr} - \mu \times r \times \frac{d\sigma_r}{dr} = 0$$

$$\left( r \frac{d\sigma_r}{dr} \right) (1 + \mu) + \rho r^2 \omega^2 (1 + \mu) + r \frac{d\sigma_c}{dr} - \mu \times r \times \frac{d\sigma_r}{dr} = 0$$

$$r \frac{d\sigma_r}{dr} + \mu \times r \frac{d\sigma_r}{dr} + \rho r^2 \times \omega^2 (1 + \mu) + r \frac{d\sigma_c}{dr} - \mu \times r \frac{d\sigma_r}{dr} = 0$$

$$r \frac{d\sigma_r}{dr} + \rho r^2 \times \omega^2 (1 + \mu) + r \frac{d\sigma_c}{dr} = 0$$

Dividing by 'r' to both sides, we get

$$\frac{d\sigma_r}{dr} + \rho \times r \times \omega^2 (1 + \mu) + \frac{d\sigma_c}{dr} = 0$$

$$\frac{d\sigma_r}{dr} + \frac{d\sigma_c}{dr} = -\rho \times r \times \omega^2 (1 + \mu)$$

Integrating, we get

$$\sigma_r + \sigma_c = -\rho \times \frac{r^2}{2} \times \omega^2 \times (1 + \mu) + C_1 \quad \dots(vii)$$

where  $C_1$  is a constant of integration.

Subtracting equation (i) from equation (vii), we get

$$2\sigma_r = -\frac{\rho \times r^2 \times \omega^2 \times (1 + \mu)}{2} + C_1 - r \frac{d\sigma_r}{dr} - \rho r^2 \times \omega^2$$

$$= -\frac{\rho \times r^2 \times \omega^2}{2} [(1 + \mu) + 2] + C_1 - r \frac{d\sigma_r}{dr}$$

$$\text{or} \quad 2\sigma_r + r \frac{d\sigma_r}{dr} = -\frac{\rho \times \omega^2 \times r^2}{2} (3 + \mu) + C_1$$

Multiplying by  $r$  to both sides, we get

$$2 \times r \times \sigma_r + r^2 \frac{d\sigma_r}{dr} = -\frac{\rho \times \omega^2 \times r^3}{2} (3 + \mu) + C_1 \times r$$

$$\text{or} \quad \frac{d}{dr} (r^2 \times \sigma_r) = -\frac{\rho \times \omega^2 \times r^3}{2} (3 + \mu) + C_1 \times r$$

Integrating both sides, we get

$$r^2 \times \sigma_r = -\frac{\rho \times \omega^2}{2} \times \frac{r^4}{4} \times (3 + \mu) + \frac{C_1 \times r^2}{2} + C_2$$

(where  $C_2$  is constant of integration)

$$\begin{aligned} \text{or} \quad \sigma_r &= -\frac{\rho \times \omega^2 \times r^2}{8} (3 + \mu) + \frac{C_1}{2} + \frac{C_2}{r^2} \\ &= \frac{C_1}{2} + \frac{C_2}{r^2} - \frac{\rho \times \omega^2 \times r^2}{8} (3 + \mu) \quad \dots(22.1) \end{aligned}$$

Equation (22.1) gives the expression for radial stress in terms of constants  $C_1$  and  $C_2$ . To get the value of  $\sigma_c$  in terms of constants  $C_1$  and  $C_2$ , substitute equation (22.1) into equation (vii).

$$\therefore \frac{C_1}{2} + \frac{C_2}{r^2} - \frac{\rho \times \omega^2 \times r^2}{8} (3 + \mu) + \sigma_c = -\frac{\rho \times r^2 \times \omega^2}{2} (1 + \mu) + C_1$$

$$\text{or} \quad \sigma_c = -\frac{C_1}{2} - \frac{C_2}{r^2} + \frac{\rho \times \omega^2 \times r^2}{8} (3 + \mu) - \frac{\rho \times r^2 \times \omega^2}{2} (1 + \mu) + C_1$$

$$= \frac{C_1}{2} - \frac{C_2}{r^2} + \frac{\rho \times \omega^2 \times r^2}{8} (3 + \mu - 4 - 4\mu)$$

$$= \frac{C_1}{2} - \frac{C_2}{r^2} + \frac{\rho \times \omega^2 \times r^2}{8} (-1 - 3\mu)$$

$$= \frac{C_1}{2} - \frac{C_2}{r^2} - \frac{\rho \times \omega^2 \times r^2}{8} (1 + 3\mu) \quad \dots(22.2)$$

The constants  $C_1$  and  $C_2$  are obtained from boundary conditions. In equations (22.1) and (22.2), L.H.S. is in  $N/m^2$ , hence every term on R.H.S. should be in  $N/m^2$ . Hence  $C_1$  and  $C_2$  will be in  $N/m^2$ .

### 22.2.1. Expression for Circumferential Stress and Radial Stress in a Solid Disc.

From equations (22.1) and (22.2), it is clear that the stresses set up in a rotating disc will become infinite at the centre of the disc where  $r = 0$ . But the stresses at the centre, can not be infinite. Hence  $C_2$  should be zero. Substituting  $C_2 = 0$  in these equations, we get

$$\sigma_r = \frac{C_1}{2} - \frac{\rho \times \omega^2 \times r^2}{8} (3 + \mu) \quad \dots(A)$$

$$\text{and} \quad \sigma_c = \frac{C_1}{2} - \frac{\rho \times \omega^2 \times r^2}{8} (1 + 3\mu) \quad \dots(B)$$

The value of  $C_1$  will be obtained from boundary condition.

At the outer radius,  $\sigma_r = 0$ . This means at  $r = r_2$ ,  $\sigma_r = 0$

Substituting  $\sigma_r = 0$  at  $r = r_2$  in equation (A), we get

$$0 = \frac{C_1}{2} - \frac{\rho \times \omega^2 \times r_2^2}{8} (3 + \mu)$$

or

$$\frac{C_1}{2} = \frac{\rho \times \omega^2 \times r_2^2}{8} (3 + \mu)$$

or

$$C_1 = \frac{\rho \times \omega^2 \times r_2^2}{4} (3 + \mu)$$

Substituting the value of  $C_1$  in equations (A) and (B), we get

$$\begin{aligned} \sigma_r &= \frac{\rho \times \omega^2 \times r_2^2}{4 \times 2} (3 + \mu) - \frac{\rho \times \omega^2 \times r^2}{8} (3 + \mu) \\ &= \frac{\rho \times \omega^2}{8} (3 + \mu) [r_2^2 - r^2] \end{aligned} \quad \dots(22.3)$$

and

$$\begin{aligned} \sigma_c &= \frac{\rho \times \omega^2 \times r_2^2}{4 \times 2} (3 + \mu) - \frac{\rho \times \omega^2 \times r^2}{8} (1 + 3\mu) \\ &= \frac{\rho \times \omega^2}{8} [(3 + \mu)r_2^2 - (1 + 3\mu)r^2] \end{aligned} \quad \dots(22.4)$$

At the centre,  $r = 0$  [Substituting  $r = 0$  in equations (22.3) and (22.4)]

$$\therefore \sigma_r = \frac{\rho \times \omega^2}{8} (3 + \mu)r_2^2$$

and

$$\sigma_c = \frac{\rho \times \omega^2}{8} (3 + \mu)r_2^2$$

Hence maximum stresses are at the centre and they are equal.

$$\therefore (\sigma_r)_{\max} = (\sigma_c)_{\max} = \frac{\rho \times \omega^2}{8} (3 + \mu)r_2^2 \quad \dots(22.5)$$

At the outer radius, radial stress ( $\sigma_r$ ) is zero, but circumferential stress is not zero. By substituting  $r = r_2$  in equation (22.4), we get circumferential stress at outer radius. This is equal to

$$\begin{aligned} \sigma_c \text{ at outer radius} &= \frac{\rho \times \omega^2}{8} [(3 + \mu)r_2^2 - (1 + 3\mu)r_2^2] \\ &= \frac{\rho \times \omega^2}{8} \times r_2^2 [3 + \mu - 1 - 3\mu] \\ &= \frac{\rho \times \omega^2 \times r_2^2}{8} (2 - 2\mu) = \frac{\rho \times \omega^2 \times r_2^2}{4} (1 - \mu) \end{aligned} \quad \dots(22.6)$$

The variation of circumferential and radial stresses are shown in Fig. 22.2.

**22.2.2. Expression for  $\sigma_r$  and  $\sigma_c$  for Disc with Central Hole.** The equations (22.1) and (22.2) gives the radial and circumferential stresses in terms of constants as

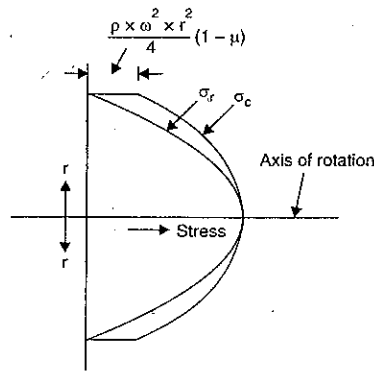

Fig. 22.2

$$\sigma_r = \frac{C_1}{2} + \frac{C_2}{r^2} - \frac{\rho \times \omega^2 \times r^2}{8} (3 + \mu)$$

and

$$\sigma_c = \frac{C_1}{2} - \frac{C_2}{r^2} - \frac{\rho \times \omega^2 \times r^2}{8} (1 + 3\mu)$$

To find  $C_1$  and  $C_2$ , the boundary conditions are used. If  $r_1$  and  $r_2$  are the inner and outer radii, then radial stress is zero at these radii. This means  $\sigma_r = 0$  at  $r = r_1$  and at  $r = r_2$ .

Substituting these values, we get two equations as

$$0 = \frac{C_1}{2} + \frac{C_2}{r_1^2} - \frac{\rho \times \omega^2 \times r_1^2}{8} (3 + \mu) \quad [\text{Here } \sigma_r = 0 \text{ at } r = r_1] \quad \dots(i)$$

$$0 = \frac{C_1}{2} + \frac{C_2}{r_2^2} - \frac{\rho \times \omega^2 \times r_2^2}{8} (3 + \mu) \quad [\text{Here } \sigma_r = 0 \text{ at } r = r_2] \quad \dots(ii)$$

Subtracting equation (ii) from equation (i), we get

$$\begin{aligned} 0 &= \frac{C_2}{r_1^2} - \frac{C_2}{r_2^2} - \frac{\rho \times \omega^2 \times r_1^2}{8} (3 + \mu) + \frac{\rho \times \omega^2 \times r_2^2}{8} (3 + \mu) \\ &= C_2 \left[ \frac{1}{r_1^2} - \frac{1}{r_2^2} \right] - \frac{\rho \times \omega^2}{8} (3 + \mu) [r_1^2 - r_2^2] \end{aligned}$$

or

$$C_2 \left[ \frac{r_2^2 - r_1^2}{r_1^2 r_2^2} \right] = \frac{\rho \times \omega^2}{8} (3 + \mu) [r_1^2 - r_2^2]$$

$$= - \frac{\rho \times \omega^2}{8} (3 + \mu) (r_2^2 - r_1^2)$$

or

$$\frac{C_2}{r_1^2 r_2^2} = - \frac{\rho \times \omega^2}{8} (3 + \mu) \quad [\text{Cancelling } (r_2^2 - r_1^2) \text{ to both sides}]$$

∴

$$C_2 = - \frac{\rho \times \omega^2}{8} (3 + \mu) r_1^2 r_2^2 \quad \dots(iii)$$

Substituting the value of  $C_2$  in equation (i), we get

$$\begin{aligned} 0 &= \frac{C_1}{2} + \left[ - \frac{\rho \times \omega^2}{8} (3 + \mu) r_1^2 r_2^2 \right] \times \frac{1}{r_1^2} - \frac{\rho \times \omega^2 \times r_1^2}{8} \times (3 + \mu) \\ &= \frac{C_1}{2} - \frac{\rho \times \omega^2 \times r_2^2}{8} (3 + \mu) - \frac{\rho \times \omega^2 \times r_1^2}{8} (3 + \mu) \end{aligned}$$

or

$$- \frac{C_1}{2} = - \frac{\rho \times \omega^2}{8} (3 + \mu) [r_2^2 + r_1^2]$$

or

$$C_1 = \frac{\rho \times \omega^2}{4} \times (3 + \mu) (r_2^2 + r_1^2) \quad \dots(iv)$$

Substituting the values of  $C_1$  and  $C_2$  in equations (22.1) and (22.2), we get

$$\begin{aligned} \sigma_r &= \frac{\rho \times \omega^2}{4 \times 2} (3 + \mu) (r_2^2 + r_1^2) + \left[ - \frac{\rho \times \omega^2}{8} (3 + \mu) \frac{r_1^2 r_2^2}{r^2} \right] - \frac{\rho \times \omega^2 \times r^2}{8} (3 + \mu) \\ &= \frac{\rho \times \omega^2}{8} \times (3 + \mu) \left[ (r_2^2 + r_1^2) - \frac{r_1^2 r_2^2}{r^2} - r^2 \right] \end{aligned} \quad \dots(22.7)$$

and

$$\sigma_c = \frac{\rho \times \omega^2}{4 \times 2} (3 + \mu) \times (r_2^2 + r_1^2) - \left[ \frac{\rho \times \omega^2 (3 + \mu) r_1^2 r_2^2}{8 r^2} \right] - \frac{\rho \times \omega^2 \times r^2}{8} (1 + 3\mu)$$

$$= \frac{\rho \times \omega^2}{8} (3 + \mu) \left[ (r_2^2 + r_1^2) + \frac{r_1^2 r_2^2}{r^2} - \frac{r^2(1 + 3\mu)}{(3 + \mu)} \right] \quad \dots(22.8)$$

Equations (22.7) and (22.8) give the expression for radial stress and circumferential stress at any radius 'r' in a disc with a central hole.

**Maximum value of  $\sigma_c$ .** From equation (22.8), it is clear that circumferential stress goes on decreasing with the increase of radius. Hence  $\sigma_c$  is maximum when radius is minimum i.e., when  $r = r_1$ ,  $\sigma_c$  is maximum. Substituting  $r = r_1$  in equation (22.8), we get maximum value of  $\sigma_c$ .

$$\begin{aligned} \therefore (\sigma_c)_{\max} &= \frac{\rho \times \omega^2}{8} (3 + \mu) \left[ (r_2^2 + r_1^2) + \frac{r_1^2 r_2^2}{r_1^2} - \frac{r_1^2(1 + 3\mu)}{(3 + \mu)} \right] \\ &= \frac{\rho \times \omega^2}{8} (3 + \mu) \left[ r_2^2 + r_1^2 + r_2^2 - \frac{r_1^2(1 + 3\mu)}{(3 + \mu)} \right] \\ &= \frac{\rho \times \omega^2}{8} (3 + \mu) \left[ 2r_2^2 + \frac{r_1^2(3 + \mu) - r_1^2(1 + 3\mu)}{(3 + \mu)} \right] \\ &= \frac{\rho \times \omega^2}{8} (3 + \mu) \left[ 2r_2^2 + \frac{r_1^2}{(3 + \mu)} (3 + \mu - 1 - 3\mu) \right] \\ &= \frac{\rho \times \omega^2}{8} (3 + \mu) \left[ 2r_2^2 + \frac{r_1^2}{(3 + \mu)} (2 - 2\mu) \right] \\ &= \frac{\rho \times \omega^2}{8} (3 + \mu) \left[ 2r_2^2 + 2r_1^2 \frac{(1 - \mu)}{(3 + \mu)} \right] \\ &= \frac{\rho \times \omega^2}{8} (3 + \mu) \times 2 \left[ r_2^2 + \frac{r_1^2(1 - \mu)}{3 + \mu} \right] \\ &= \frac{\rho \times \omega^2}{4} (3 + \mu) \left[ r_2^2 + \frac{(1 - \mu)}{3 + \mu} r_1^2 \right] \quad \dots(22.9) \end{aligned}$$

Equation (22.9) gives the maximum value of  $\sigma_c$ .

If  $r_1 \rightarrow r_2 = r$ , then

$$\begin{aligned} (\sigma_c)_{\max} &= \frac{\rho \times \omega^2}{4} (3 + \mu) \left[ r^2 + \frac{(1 - \mu)}{3 + \mu} r^2 \right] \\ &= \frac{\rho \times \omega^2}{4} (3 + \mu) \left[ \frac{r^2(3 + \mu) + (1 - \mu)r^2}{(3 + \mu)} \right] \\ &= \frac{\rho \times \omega^2}{4} \times r^2 (3 + \mu + 1 - \mu) = \rho \times \omega^2 \times r^2 \end{aligned}$$

which is same as of a thin rotating cylinder.

**Maximum value of  $\sigma_r$ .** The value of  $\sigma_r$  will be maximum, if  $\frac{d\sigma_r}{dr} = 0$ . Hence differenti-

ating equation (22.7) w.r.t.  $r$  and putting  $\frac{d\sigma_r}{dr} = 0$ , we get

$$\frac{d}{dr} \left[ \frac{\rho \omega^2}{8} (3 + \mu) \left( r_2^2 + r_1^2 - \frac{r_1^2 r_2^2}{r^2} - r^2 \right) \right] = 0$$

$$\frac{\rho \times \omega^2}{8} (3 + \mu) \left( 0 + 0 - \frac{r_1^2 r_2^2 (-2)}{r^3} - 2r \right) = 0$$

or

$$\frac{2r_1^2 r_2^2}{r^3} - 2r = 0$$

or

$$r_1^2 r_2^2 - r^4 = 0 \quad \text{or} \quad r^4 = r_1^2 r_2^2$$

or

$$r^2 = r_1 r_2 \quad \text{or} \quad r = \sqrt{r_1 \times r_2}$$

or

$$\dots(22.10)$$

Equation (22.10) gives the condition for  $\sigma_r$  to be maximum.

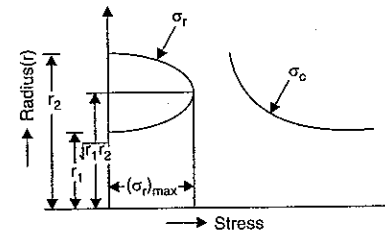

Fig. 22.3

Substituting  $r = \sqrt{r_1 \times r_2}$  in equation (22.7), we get maximum value of  $\sigma_r$ .

$$\begin{aligned} \therefore (\sigma_r)_{\max} &= \frac{\rho \times \omega^2}{8} (3 + \mu) \left[ r_2^2 + r_1^2 - \frac{r_1^2 r_2^2}{r_1 r_2} - r_1 r_2 \right] \\ &= \frac{\rho \times \omega^2}{8} (3 + \mu) [r_2^2 + r_1^2 - 2r_1 r_2] \\ &= \frac{\rho \times \omega^2}{8} (3 + \mu) (r_2 - r_1)^2 \quad \dots(22.11) \end{aligned}$$

**Value of  $\sigma_c$  at the outer surface of a disc with central hole**

Substituting  $r = r_2$  in equation (22.8), we get the value of  $\sigma_c$  at outer radius.

$$\begin{aligned} \therefore \sigma_c &= \frac{\rho \times \omega^2}{8} (3 + \mu) \left[ r_2^2 + r_1^2 + \frac{r_1^2 r_2^2}{r_2^2} - r_2^2 \frac{(1 + 3\mu)}{3 + \mu} \right] \\ &= \frac{\rho \times \omega^2}{8} (3 + \mu) \left[ r_2^2 + 2r_1^2 - r_2^2 \frac{(1 + 3\mu)}{3 + \mu} \right] \end{aligned}$$

$$\begin{aligned}
 &= \frac{\rho \times \omega^2}{8} (3 + \mu) \left[ 2r_1^2 + r_2^2 \frac{(3 + \mu - 1 - 3\mu)}{3 + \mu} \right] \\
 &= \frac{\rho \times \omega^2}{8} (3 + \mu) \left[ 2r_1^2 + \frac{r_2^2}{(3 + \mu)} (2 - 2\mu) \right] \\
 &= \frac{\rho \times \omega^2}{4} (3 + \mu) \left[ r_1^2 + \left( \frac{1 - \mu}{3 + \mu} \right) r_2^2 \right] \quad \dots(22.12)
 \end{aligned}$$

**22.2.3. Expression for Maximum  $\sigma_c$  and Maximum  $\sigma_r$  for a Hollow Disc with a Pin Hole at the Centre.** For a disc with a pin hole at the centre,  $r_1 \rightarrow 0$ . Hence substituting  $r_1 = 0$  in the equations (22.9) and (22.11), we get the expression for  $\sigma_r$  and  $\sigma_c$  for a disc with pin hole at the centre.

$$(\sigma_r)_{\max} = \frac{\rho \times \omega^2}{8} (3 + \mu) r_2^2 = \frac{\rho \times \omega^2 \times r_2^2}{8} (3 + \mu) \quad \dots(22.13)$$

$$\text{and} \quad (\sigma_c)_{\max} = \frac{\rho \times \omega^2}{4} (3 + \mu) r_2^2 = \frac{\rho \times \omega^2 \times r_2^2}{4} (3 + \mu) \quad \dots(22.14)$$

The maximum circumferential stress in a solid disc is given by equation (22.5), as

$$(\sigma_c)_{\max} \text{ for solid disc} = \frac{\rho \times \omega^2}{8} (3 + \mu) r_2^2.$$

If we compare the maximum circumferential stress in a solid disc and in a disc with a pin hole at the centre, the maximum circumferential stress in a disc with a pin hole at the centre is two times the maximum circumferential stress in a solid disc.

**Problem 22.1.** A steel disc of uniform thickness and of diameter 900 mm is rotating about its axis at 3000 r.p.m. Determine the radial and circumferential stresses at the centre and outer radius. The density of material is 7800 kg/m<sup>3</sup> and Poisson's ratio = 0.3.

**Sol.** Given :

$$\text{Diameter} = 900 \text{ mm} \quad \therefore \text{Radius of disc, } r = \frac{900}{2} = 450 \text{ mm} = 0.45 \text{ m}$$

$$\text{Speed, } N = 3000 \text{ r.p.m.}$$

$$\therefore \text{Angular speed, } \omega = \frac{2\pi N}{60} = \frac{2\pi \times 3000}{60} = 100\pi \text{ rad/s}$$

$$\text{Density, } \rho = 7800 \text{ kg/m}^3$$

$$\text{Poisson's ratio, } \mu = 0.3$$

The radial and circumferential stresses are given by equations (22.1) and (22.2) as

$$\sigma_r = \frac{C_1}{2} + \frac{C_2}{r^2} - \frac{\rho \times \omega^2 \times r^2}{8} (3 + \mu) \quad \dots(i)$$

and

$$\sigma_c = \frac{C_1}{2} - \frac{C_2}{r^2} - \frac{\rho \times \omega^2 \times r^2}{8} (1 + 3\mu) \quad \dots(ii)$$

As the stresses cannot have infinite value at  $r = 0$ , hence  $C_2$  should be zero. Hence equations (i) and (ii) becomes as

$$\sigma_r = \frac{C_1}{2} - \frac{\rho \times \omega^2 \times r^2}{8} (3 + \mu) \quad \dots(iii)$$

and

$$\sigma_c = \frac{C_1}{2} - \frac{\rho \times \omega^2 \times r^2}{8} (1 + 3\mu) \quad \dots(iv)$$

Also at the outer radius,  $\sigma_r = 0$ . This means at  $r = 0.45 \text{ m}$ ,  $\sigma_r = 0$ . Substituting these values in equation (iii), we get

$$\begin{aligned}
 0 &= \frac{C_1}{2} - \frac{\rho \times \omega^2 \times (0.45)^2}{8} (3 + \mu) \\
 \text{or} \quad \frac{C_1}{2} &= \frac{\rho \times \omega^2 \times (0.45)^2}{8} (3 + \mu) \quad \text{or} \quad C_1 = \frac{\rho \times \omega^2 \times (0.45)^2}{4} (3 + \mu) \\
 &= \frac{7800 \times (100\pi)^2 \times (0.45)^2 (3 + 0.3)}{4} = 128.6 \times 10^6 \text{ N/m}^2
 \end{aligned}$$

Substituting the value of  $C_1$  in equations (iii) and (iv), we get

$$\sigma_r = \frac{128.6 \times 10^6}{2} - \frac{\rho \times \omega^2 \times r^2}{8} (3 + \mu)$$

and

$$\sigma_c = \frac{128.6 \times 10^6}{2} - \frac{\rho \times \omega^2 \times r^2}{8} (1 + 3\mu)$$

At  $r = 0$ ,

$$\sigma_r = \sigma_c = \frac{128.6 \times 10^6}{2} = 64.3 \times 10^6 \text{ N/m}^2 = 64.3 \text{ MN/m}^2. \quad \text{Ans.}$$

At  $r = 0.45$ ,  $\sigma_r = 0$

$$\begin{aligned}
 \sigma_c &= \frac{128.6 \times 10^6}{2} - \frac{7800 \times (100\pi)^2 \times (0.45)^2}{8} (1 + 3 \times 0.3) \\
 &= 64.3 \times 10^6 - 37.024 \times 10^6 \text{ N/m}^2 \\
 &= 27.276 \times 10^6 \text{ N/m}^2 = 27.276 \text{ MN/m}^2. \quad \text{Ans.}
 \end{aligned}$$

#### Alternate Method

(i) *Stresses at the centre.* The radial stress and circumferential stress at the centre of a solid disc are maximum and are equal. They are given by equation (22.5) as

$$(\sigma_r)_{\max} = (\sigma_c)_{\max} = \frac{\rho \times \omega^2}{8} (3 + \mu) r_2^2$$

where  $r_2 = \text{Outer radius} = 0.45 \text{ m}$

$$\begin{aligned}
 \therefore (\sigma_r)_{\max} = (\sigma_c)_{\max} &= \frac{7800 \times (100\pi)^2}{8} (3 + 0.3) \times (0.45)^2 \\
 &= 64.3 \times 10^6 \text{ N/m}^2 = 64.3 \text{ MN/m}^2. \quad \text{Ans.}
 \end{aligned}$$

(ii) *Stresses at the outer radius*

The radial stress at the outer surface is zero.

$$\therefore \sigma_r = 0$$

The circumferential stress at outer radius is given by equation (22.6) as

$$\begin{aligned}
 \sigma_c &= \frac{\rho \times \omega^2 \times r_2^2}{4} (1 - \mu) = \frac{7800 \times (100\pi)^2 \times 0.45^2}{4} (1 - 0.3) \\
 &= 27.28 \times 10^6 \text{ N/m}^2 = 27.28 \text{ MN/m}^2. \quad \text{Ans.}
 \end{aligned}$$

At any section, there are radial and circumferential stresses which are perpendicular to each other and tensile in nature. There is no shear stress. Hence these stresses are also known as **principal stresses**. Hence the above stresses are also principal stresses.

**Problem 22.2.** If for the problem 22.1, the disc is having a central hole of 150 mm diameter, then determine :

(i) circumferential stress at inner radius and outer radius,

(ii) radius at which radial stress is maximum, and

(iii) maximum radial stress.



**Sol. Given :**

From Problem 22.1,

$$\begin{aligned} \text{Outer radius, } r_2 &= 0.45 \text{ m,} \\ \text{Angular speed, } \omega &= (100 \pi) \text{ rad/s} \\ \rho &= 7800 \text{ kg/m}^3, \mu = 0.3 \end{aligned}$$

$$\text{Inner dia} = 150 \text{ mm, } \therefore \text{Inner radius, } r_1 = \frac{150}{2} = 75 \text{ mm} = 0.075 \text{ m}$$

(i) *Circumferential stress ( $\sigma_c$ ) at inner and outer radii*

The circumferential stress in a disc with central hole is maximum at the inner radius.

This stress is given by equation (22.9) as

$$\begin{aligned} (\sigma_c)_{\max} &= \frac{\rho \times \omega^2}{4} (3 + \mu) \left[ r_2^2 + \left( \frac{1 - \mu}{3 + \mu} \right) r_1^2 \right] \\ &= \frac{7800 \times (100 \pi)^2}{4} (3 + 0.3) \left[ 0.45^2 + \left( \frac{1 - 0.3}{3 + 0.3} \right) (0.075)^2 \right] \\ &= 635.109 \times 10^6 [0.2025 + 1.193 \times 10^{-3}] \\ &= 129.367 \times 10^6 \text{ N/m}^2 = \mathbf{129.367 \text{ MN/m}^2}. \text{ Ans.} \end{aligned}$$

The circumferential stress at the outer radius is given by equation (22.12) as

$$\begin{aligned} \sigma_c &= \frac{\rho \times \omega^2}{4} (3 + \mu) \left[ r_1^2 + \left( \frac{1 - \mu}{3 + \mu} \right) r_2^2 \right] \\ &= \frac{7800 \times (100 \pi)^2 \times (3 + 0.3)}{4} \left[ 0.075^2 + \left( \frac{1 - 0.3}{3 + 0.3} \right) \times 0.45^2 \right] \\ &= 635.109 \times 10^6 [5.625 \times 10^{-3} + 0.04295] \\ &= 30.85 \times 10^6 \text{ N/m}^2 = \mathbf{30.85 \text{ MN/m}^2}. \text{ Ans.} \end{aligned}$$

(ii) *Radius at which radial stress is maximum*

The radius at which radial stress is maximum is given by equation (22.10) as

$$r = \sqrt{r_1 \times r_2} = \sqrt{0.075 \times 0.45} = \mathbf{0.1837 \text{ m}}. \text{ Ans.}$$

(iii) *Maximum radial stress*

The maximum radial stress is given by equation (22.11) as

$$\begin{aligned} (\sigma_r)_{\max} &= \frac{\rho \times \omega^2}{8} (3 + \mu) (r_2 - r_1)^2 \\ &= \frac{7800 \times (100 \pi)^2}{8} (3 + 0.3) (0.45 - 0.075)^2 \\ &= 317.5545 \times 10^6 (0.375)^2 \\ &= 44.656 \times 10^6 \text{ N/m}^2 = \mathbf{44.656 \text{ MN/m}^2}. \text{ Ans.} \end{aligned}$$

**Problem 22.3.** For the data given in Problem 22.1, plot the variations of circumferential and radial stresses along the radius of the solid disc. Take radius along y-axis and stresses along x-axis. Also plot these variations taking 'r' along x-axis and stresses along y-axis.

**Sol. Given :**

Data from Problem 22.1

$$\begin{aligned} N &= 3000 \text{ r.p.m., } \omega = (100 \pi) \text{ rad/s} \\ \rho &= 7800 \text{ kg/m}^3, \mu = 0.3, \text{ outer radius, } r_2 = 0.45 \text{ m} \end{aligned}$$

(i) *Circumferential stress ( $\sigma_c$ )*

The circumferential stress for a solid disc at any radius 'r' is given by equation (22.4) as

$$\begin{aligned} \sigma_c &= \frac{\rho \times \omega^2}{8} [(3 + \mu)r_2^2 - (1 + 3\mu)r^2] \\ &= \frac{7800 \times (100 \pi)^2}{8} [(3 + 0.3) \times 0.45^2 - (1 + 3 \times 0.3) r^2] \\ &= 96.228 \times 10^6 [0.66825 - 1.9 r^2] \end{aligned}$$

By substituting different values of r in the above equation, different values of  $\sigma_c$  are obtained as given below :

$$\begin{aligned} \text{At } r = 0, \quad \sigma_c &= 96.228 \times 10 \times 0.66825 = 64.3 \times 10^6 \text{ N/m}^2 = 64.3 \text{ MN/m}^2 \\ &= 0.05 \text{ m, } \sigma_c = 96.228 \times 10^6 [0.66825 - 1.9 \times 0.05^2] = 63.84 \times 10^6 \text{ N/m}^2 = 63.84 \text{ MN/m}^2 \\ &= 0.1 \text{ m, } \sigma_c = 96.228 \times 10^6 [0.66825 - 1.9 \times 0.1^2] = 62.47 \times 10^6 \text{ N/m}^2 = 62.47 \text{ MN/m}^2 \\ &= 0.2 \text{ m, } \sigma_c = 96.228 \times 10^6 [0.66825 - 1.9 \times 0.2^2] = 56.99 \times 10^6 \text{ N/m}^2 = 56.99 \text{ MN/m}^2 \\ &= 0.3 \text{ m, } \sigma_c = 96.228 \times 10^6 [0.66825 - 1.9 \times 0.3^2] = 47.85 \times 10^6 \text{ N/m}^2 = 47.85 \text{ MN/m}^2 \\ &= 0.4 \text{ m, } \sigma_c = 96.228 \times 10^6 [0.66825 - 1.9 \times 0.4^2] = 35.05 \times 10^6 \text{ N/m}^2 = 35.05 \text{ MN/m}^2 \\ &= 0.45 \text{ m, } \sigma_c = 96.228 \times 10^6 [0.66825 - 1.9 \times 0.45^2] = 27.28 \times 10^6 \text{ N/m}^2 = 27.28 \text{ MN/m}^2 \end{aligned}$$

(ii) *Radial stress ( $\sigma_r$ )*

The radial stress for a solid disc at any radius 'r' is given by equation (22.3) as

$$\begin{aligned} \sigma_r &= \frac{\rho \times \omega^2}{8} (3 + \mu) (r_2^2 - r^2) \\ &= \frac{7800 \times (100 \pi)^2}{8} (3 + 0.3) (0.45^2 - r^2) \text{ N/m}^2 \\ &= 317.5545 \times 10^6 (0.2025 - r^2) \text{ N/m}^2 \\ &= 317.5545 (0.2025 - r^2) \text{ MN/m}^2 \end{aligned}$$

By substituting different values of 'r' in the above equation, different values of  $\sigma_r$  are obtained as given below :

$$\begin{aligned} \text{At } r = 0, \quad \sigma_r &= 317.5545 (0.2025 - 0) = 64.3 \text{ MN/m}^2 \\ r = 0.05 \text{ m, } \sigma_r &= 317.5545 (0.2025 - 0.05^2) = 63.5 \text{ MN/m}^2 \\ r = 0.1 \text{ m, } \sigma_r &= 317.5545 (0.2025 - 0.1^2) = 61.13 \text{ MN/m}^2 \\ r = 0.2 \text{ m, } \sigma_r &= 317.5545 (0.2025 - 0.2^2) = 51.6 \text{ MN/m}^2 \\ r = 0.3 \text{ m, } \sigma_r &= 317.5545 (0.2025 - 0.3^2) = 35.7 \text{ MN/m}^2 \\ r = 0.4 \text{ m, } \sigma_r &= 317.5545 (0.2025 - 0.4^2) = 13.5 \text{ MN/m}^2 \\ r = 0.45 \text{ m, } \sigma_r &= 317.5545 (0.2025 - 0.45^2) = 0 \end{aligned}$$

The variation of  $\sigma_c$  and  $\sigma_r$  along the radius (taking radius along y-axis and stress along x-axis) are plotted as shown in Fig. 22.4.

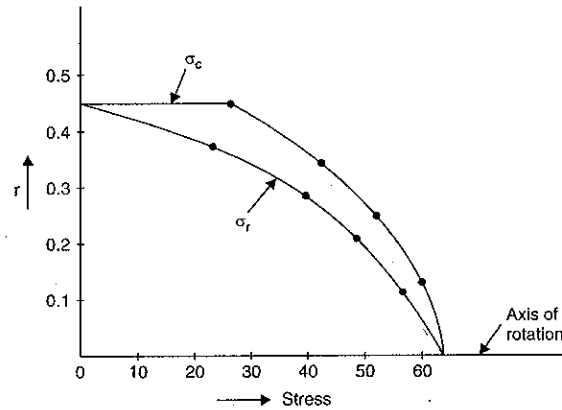

Fig. 22.4

If radius is taken along  $x$ -axis and stresses along  $y$ -axis, then variation of  $\sigma_c$  and  $\sigma_r$  will be as shown in Fig. 22.5.

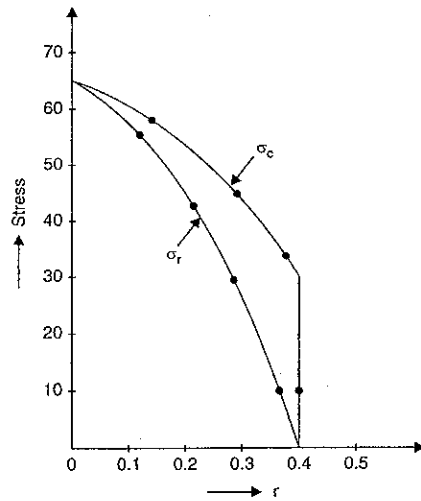

Fig. 22.5

**Problem 22.4.** For the problem 22.2, plot the variation of circumferential and radial stresses along the radius of disc with a central hole.

**Sol. Given :**

Data from Problem 22.2,

Outer radius,  $r_2 = 0.45$  m ; inner radius,  $r_1 = 0.075$  m

$N = 3000$  r.p.m. ;  $\omega = 100 \pi$  rad/s ;  $\mu = 0.3$ ,  $\rho = 7800$  kg/m<sup>3</sup>

(i) Circumferential stress ( $\sigma_c$ )

The circumferential stress for a disc with a hole at the centre is given by equation (22.8), as

$$\begin{aligned}\sigma_c &= \frac{\rho \times \omega^2}{8} (3 + \mu) \left[ (r_2^2 + r_1^2) + \frac{r_1^2 r_2^2}{r^2} - \left( \frac{1 + 3\mu}{3 + \mu} \right) r^2 \right] \\ &= \frac{7800 \times (100 \pi)^2}{8} (3 + 0.3) \left[ (0.45^2 + 0.075^2) + \frac{0.075^2 \times 0.45^2}{r^2} - \left( \frac{1 + 3 \times 0.3}{3 + 0.3} \right) r^2 \right] \\ &= 317.55 \times 10^6 \left[ 0.208125 + \frac{1.139 \times 10^{-3}}{r^2} - 0.575 r^2 \right] \text{ N/m}^2 \\ &= 317.55 \left[ 0.208125 + \frac{1.139 \times 10^{-3}}{r^2} - 0.575 r^2 \right] \text{ MN/m}^2\end{aligned}$$

By substituting different values of  $r$  in the above equation, different values of  $\sigma_c$  are obtained. Let us start from inner radius i.e., from  $r = 0.075$  m

$$\begin{aligned}\text{At } r = 0.075 \text{ m, } \sigma_c &= 317.55 \left( 0.208125 + \frac{1.139 \times 10^{-3}}{0.075^2} - 0.575 \times 0.075^2 \right) \\ &= 317.55 [0.208125 + 0.2025 - 0.00323] = 129.368 \text{ MN/m}^2\end{aligned}$$

$$\begin{aligned}\text{At } r = 0.1 \text{ m, } \sigma_c &= 317.55 \left( 0.208125 + \frac{1.139 \times 10^{-3}}{0.1^2} - 0.575 \times 0.1^2 \right) \\ &= 317.55 (0.208125 + 0.1139 - 0.00575) = 100.43 \text{ MN/m}^2\end{aligned}$$

$$\begin{aligned}\text{At } r = 0.2 \text{ m, } \sigma_c &= 317.55 \left( 0.208125 + \frac{1.139 \times 10^{-3}}{0.2^2} - 0.575 \times 0.2^2 \right) \\ &= 317.55 (0.208125 + 0.0285 - 0.023) = 67.83 \text{ MN/m}^2\end{aligned}$$

$$\begin{aligned}\text{At } r = 0.3 \text{ m, } \sigma_c &= 317.55 \left( 0.208125 + \frac{1.139 \times 10^{-3}}{0.3^2} - 0.575 \times 0.3^2 \right) \\ &= 317.55 (0.208125 + 0.01265 - 0.05175) = 50.05 \text{ MN/m}^2\end{aligned}$$

$$\begin{aligned}\text{At } r = 0.4 \text{ m, } \sigma_c &= 317.55 \left( 0.208125 + \frac{1.139 \times 10^{-3}}{0.4^2} - 0.575 \times 0.4^2 \right) \\ &= 317.55 (0.208125 + 0.007118 - 0.092) = 39.13 \text{ MN/m}^2\end{aligned}$$

$$\begin{aligned}\text{At } r = 0.45 \text{ m, } \sigma_c &= 317.55 \left( 0.208125 + \frac{1.139 \times 10^{-3}}{0.45^2} - 0.575 \times 0.45^2 \right) \\ &= 317.55 (0.208125 + 0.005625 - 0.1164) = 30.9 \text{ MN/m}^2.\end{aligned}$$

(ii) Radial stress ( $\sigma_r$ )

The radial stress for a disc with a hole at the centre is given by equation (22.7) as

$$\sigma_r = \frac{\rho \times \omega^2}{8} (3 + \mu) \left[ (r_2^2 + r_1^2) - \frac{r_1^2 r_2^2}{r^2} - r^2 \right]$$

$$\begin{aligned}
 &= \frac{7800 \times (100\pi)^2}{8} (3 + 0.3) \left[ (0.45^2 + 0.075^2) - \frac{0.075^2 \times 0.45^2}{r^2} - r^2 \right] \\
 &= 317.55 \left[ 0.208125 - \frac{1.139 \times 10^{-3}}{r^2} - r^2 \right] \times 10^6 \text{ N/m}^2 \\
 &= 317.55 \left[ 0.208125 - \frac{1.139 \times 10^{-3}}{r^2} - r^2 \right] \text{ MN/m}^2
 \end{aligned}$$

By substituting the different values of  $r$  in the above equation, different values of  $\sigma_r$  are obtained. Also  $\sigma_r = 0$  at  $r = 0.075$  m and at  $r = 0.45$  m. Also we have got in problem 22.2, that  $\sigma_r$  is maximum at  $r = \sqrt{r_1 r_2} = \sqrt{0.075 \times 0.45} = 0.1837$  m. Let us start the calculations from inner radius ( $= 0.075$  m).

$$\text{At } r = 0.075 \text{ m, } \sigma_r = 317.55 \left[ 0.208125 - \frac{1.139 \times 10^{-3}}{0.075^2} - 0.075^2 \right] = 0$$

$$\begin{aligned} \text{At } r = 0.1 \text{ m, } \sigma_r &= 317.55 \left[ 0.208125 - \frac{1.139 \times 10^{-3}}{0.1^2} - 0.1^2 \right] \\ &= 317.55 [0.208125 - 0.1139 - 0.01] = 26.74 \text{ MN/m}^2 \end{aligned}$$

$$\begin{aligned} \text{At } r = 0.1837 \text{ m, } \sigma_r &= 317.55 \left[ 0.208125 - \frac{1.139 \times 10^{-3}}{0.1837^2} - 0.1837^2 \right] \\ &= 317.55 [0.208125 - 0.03375 - 0.03375] = 44.65 \text{ MN/m}^2 \end{aligned}$$

$$\begin{aligned} r = 0.2 \text{ m, } \sigma_r &= 317.55 \left[ 0.208125 - \frac{1.139 \times 10^{-3}}{0.2^2} - 0.2^2 \right] \\ &= 317.55 [0.208125 - 0.02847 - 0.04] = 44.34 \text{ MN/m}^2 \end{aligned}$$

$$\begin{aligned} r = 0.3 \text{ m, } \sigma_r &= 317.55 \left[ 0.208125 - \frac{1.139 \times 10^{-3}}{0.3^2} - 0.3^2 \right] \\ &= 317.55 [0.208125 - 0.01265 - 0.09] = 33.49 \text{ MN/m}^2 \end{aligned}$$

$$\begin{aligned} r = 0.4 \text{ m, } \sigma_r &= 317.55 \left[ 0.208125 - \frac{1.139 \times 10^{-3}}{0.4^2} - 0.4^2 \right] \\ &= 317.55 [0.208125 - 0.007118 - 0.16] = 13.02 \text{ MN/m}^2 \end{aligned}$$

$$\begin{aligned} r = 0.45 \text{ m, } \sigma_r &= 317.55 \left[ 0.208125 - \frac{1.139 \times 10^{-3}}{0.45^2} - 0.45^2 \right] \\ &= 317.55 [0.208125 - 0.005625 - 0.2025] = 0 \text{ MN/m}^2. \end{aligned}$$

The variation of  $\sigma_c$  and  $\sigma_r$  along the radius is shown in Fig. 22.6 taking radius along  $y$ -axis and stresses along  $x$ -axis.

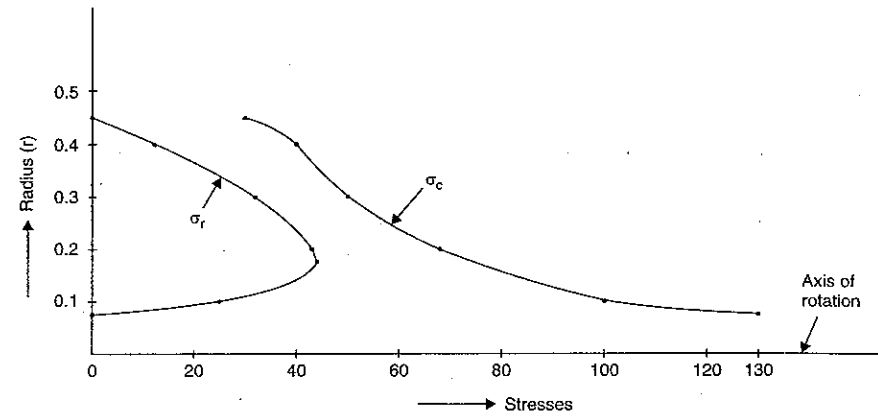

Fig. 22.6

Fig. 22.7 shows the variation of  $\sigma_c$  and  $\sigma_r$  along the radius, when radius is taken along  $x$ -axis and stresses along  $y$ -axis.

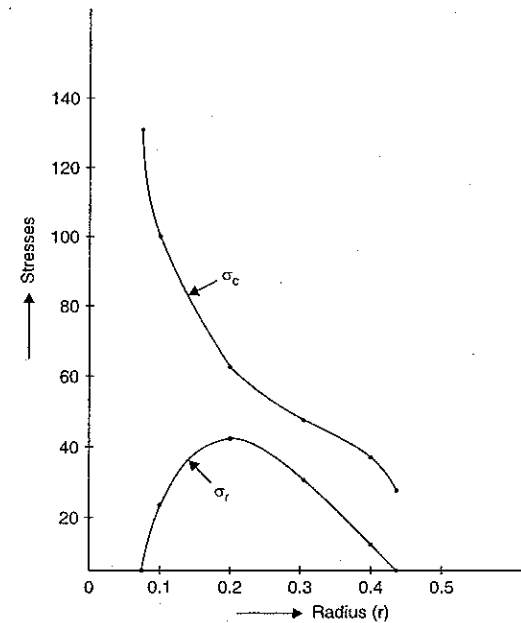

Fig. 22.7

**Problem 22.5.** For the problems 22.1 and 22.2, find the maximum shear stress in the solid disc and in the disc with a central hole.

**Sol.** The maximum shear stress at any radius is given by,  $\tau_{\max} = \frac{1}{2} (\sigma_c - \sigma_r)$

(i) *Solid disc*

In case of solid disc the stresses calculated in Problem 22.1 at the centre are  $\sigma_r = \sigma_c = 64.3 \text{ MN/m}^2$ , whereas the stresses at outer radius are  $\sigma_r = 0$  and  $\sigma_c = 27.276 \text{ MN/m}^2$ .

Hence principal stresses at the centre are :  $64.3 \text{ MN/m}^2, 64.3 \text{ MN/m}^2, 0$

$$\therefore \text{Shear stress at centre} = \frac{1}{2} (64.3 - 64.3) = 0$$

The principal stresses at the outer radius are :  $27.276 \text{ MN/m}^2, 0, 0$

$$\therefore \text{Shear stress at outer radius} = \frac{1}{2} (27.276 - 0) = 13.638 \text{ MN/m}^2$$

$\therefore$  Maximum shear stress is at the outer radius and equal to  $13.638 \text{ MN/m}^2$

$$\therefore \tau_{\max} = 13.638 \text{ MN/m}^2. \text{ Ans.}$$

(ii) *Disc with a central hole*

From Problem 22.2, the calculated values of stresses are :

At the inner radius,  $\sigma_c = 129.367 \text{ MN/m}^2, \sigma_r = 0$

At the outer radius,  $\sigma_c = 30.85 \text{ MN/m}^2, \sigma_r = 0$

$\therefore$  Principal stresses at inner radius are :  $129.367 \text{ MN/m}^2, 0, 0$

Principal stresses at outer radius are :  $30.85 \text{ MN/m}^2, 0, 0$ .

Hence maximum shear stress will be at the inner radius.

$$\begin{aligned} \therefore \sigma_{\max} &= \frac{1}{2} (\sigma_c - \sigma_r) \\ &= \frac{1}{2} (129.367 - 0) = 64.683 \text{ MN/m}^2. \text{ Ans.} \end{aligned}$$

### 22.3. DISC OF UNIFORM STRENGTH

A disc which has equal values of circumferential and radial stresses at all radii, is known as a disc of uniform strength. Hence for a disc of uniform strength,  $\sigma_r = \sigma_c = \text{constant} = \sigma$  for all radii. The thickness of the disc of uniform strength will not be constant. It will be varying as shown in Fig. 22.8 (a).

Consider an element of the disc of uniform strength at a distance 'r' from the axis of rotation and of radial width  $dr$  as shown in Fig. 22.8 (a). The same element ABCD along with radial and circumferential stresses ( $\sigma_r = \sigma_c = \sigma$ ) is shown in Fig. 22.8 (b).

Let  $t$  = Thickness of element at radius  $r$

$t + dt$  = Thickness of element at radius  $r + dr$

$\sigma$  = Stress in radial and circumferential direction

$d\theta$  = Angle subtended by faces AD and BC with centre O

$\omega$  = Angular speed of rotation.

$t_0$  = Thickness of element at radius  $r = 0$ .

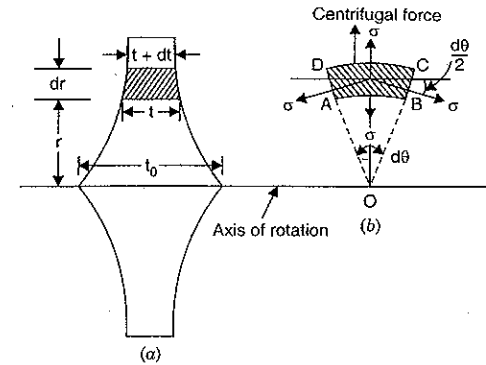

Fig. 22.8

The forces acting on the element are :

(i) Radial force due to radial stress  $\sigma$  on face AB =  $\sigma \times rd\theta \times t$

(ii) Radial force on face CD =  $\sigma \times (r + dr) d\theta \times (t + dt)$

(iii) Circumferential force on face BC =  $\sigma \times dr \times t$

(iv) Circumferential force on face AD =  $\sigma \times dr \times t$

(v) Centrifugal force on the element =  $m \times \omega^2 \times r$

where  $m$  = Mass of element

$$= \rho \times \text{Volume of element}$$

$$= \rho \times (rd\theta \times dr \times t)$$

$$\therefore \text{Centrifugal force} = (\rho \times rd\theta \times dr \times t) \times \omega^2 \times r = \rho \times \omega^2 \times r^2 \times d\theta \times dr \times t.$$

The forces in circumferential direction are equal and opposite. Considering the equilibrium of the element, and resolving all forces in radial direction, we get

$$\begin{aligned} \sigma \times r \times d\theta \times t + \sigma \times dr \times t \times \sin \frac{d\theta}{2} + \sigma \times dr \times t \times \sin \frac{d\theta}{2} \\ = \sigma \times (r + dr) d\theta \times (t + dt) + \rho \times \omega^2 \times r^2 \times d\theta \times dr \times t \end{aligned}$$

But  $\sin \frac{d\theta}{2} = \frac{d\theta}{2}$  as  $d\theta$  is very small.

Hence above equation becomes, as

$$\sigma \times rd\theta \times t + 2\sigma \times dr \times t \times \frac{d\theta}{2} = \sigma \times (r + dr) d\theta \times (t + dt) + \rho \omega^2 \times r^2 \times d\theta \times dr \times t$$

Cancelling  $d\theta$  to both sides, we get

$$\sigma \times r \times t + 2\sigma \times dr \times \frac{t}{2} = \sigma(r + dr) \times (t + dt) + \rho \omega^2 r^2 \times dr \times t$$

or

$$\begin{aligned} \sigma \times r \times t + \sigma \times dr \times t = \sigma(r \times t + rdt + tdr + dr \times dt) + \rho \omega^2 r^2 \times dr \times t \\ = \sigma(r \times t + rdt + tdr) + \rho \omega^2 r^2 \times dr \times t \end{aligned}$$

(Neglecting the product of  $dr \times dt$  i.e., product of two small quantity)

or

$$\sigma \times r \times t + \sigma \times dr \times t - \sigma \times r \times t - \sigma \times t \times dr = \rho \times \omega^2 \times r^2 \times dr \times t$$

or

$$-\sigma \times r \times dt = \rho \times \omega^2 \times r^2 \times dr \times t$$

$$\text{or } \frac{dt}{t} = -\frac{\rho \omega^2 \times r^2 \times dr}{\sigma \times r} = -\frac{\rho \times \omega^2 \times r}{\sigma} dr$$

Integrating to both sides, we get

$$\log_e t = -\frac{\rho \times \omega^2}{\sigma} \times \frac{r^2}{2} + \text{Constant}$$

The constant may be taken as  $\log_e C$  where  $C$  is also constant.

$$\therefore \log_e t = -\frac{\rho \times \omega^2 \times r^2}{2\sigma} + \log_e C$$

$$\text{or } \log_e t - \log_e C = -\frac{\rho \times \omega^2 \times r^2}{2\sigma}$$

$$\text{or } \log_e \left(\frac{t}{C}\right) = -\frac{\rho \times \omega^2 \times r^2}{2\sigma}$$

$$\therefore \frac{t}{C} = e^{-\frac{\rho \times \omega^2 \times r^2}{2\sigma}}$$

$$\text{or } t = C \times e^{-\frac{\rho \times \omega^2 \times r^2}{2\sigma}} \quad \dots(22.15)$$

The value of  $C$  is obtained from boundary condition.

At  $r = 0$ ,  $t = t_0$

Substituting this condition in equation (22.15), we get

$$t_0 = C \times e^0 = C$$

Substituting  $C = t_0$  in equation (22.5), we get

$$t = t_0 \times e^{-\frac{\rho \times \omega^2 \times r^2}{2\sigma}} \quad \dots(22.16)$$

Equation (22.16) gives the thickness of disc of uniform strength at any radius. The rotor of a steam turbine has constant strength throughout the radius and are designed according to equation (22.16).

**Problem 22.6.** A steam turbine rotor is running at 4200 r.p.m. It is to be designed for uniform strength for a stress of 85 MN/m<sup>2</sup>. If the thickness of the rotor at the centre is 25 mm and density of its material is 800 kg/m<sup>3</sup>, then find the thickness of the rotor at a radius of 350 mm.

**Sol.** Given :

Speed,  $N = 4200$  r.p.m.

$\therefore$  Angular speed,  $\omega = \frac{2\pi N}{60} = \frac{2\pi \times 4200}{60} = 140\pi$  rad/s

Thickness at the centre,  $t_0 = 25$  mm

Density,  $\rho = 8000$  kg/m<sup>3</sup>

Allowable stress,  $\sigma = 85 \times 10^6$  N/m<sup>2</sup>

Rotor is to be designed for uniform strength. This means the radial and circumferential stresses should be equal at all radii.

Let  $t =$  Thickness of the rotor at  $r = 350$  mm = 0.35 m

Using equation (22.16), we get

$$t = t_0 \times e^{-\frac{\rho \times \omega^2 \times r^2}{2\sigma}}$$

(Here  $\rho$  is in kg/m<sup>3</sup>,  $r$  in m and  $\sigma$  in N/m<sup>2</sup>. If  $t_0$  is in m then  $t$  will also be in m. If  $t_0$  is in mm,  $t$  will be in mm).

$$= \frac{8000 \times (140\pi)^2 \times (0.35)^2}{2 \times 85 \times 10^6}$$

$$= 25 \times e$$

$$= 25 \times e^{-1.115} = 8.19 \text{ mm. Ans.}$$

$$\left[ \text{where } e^{-1.115} = \frac{1}{e^{1.115}} = \frac{1}{3.049} = 0.328 \right]$$

**Problem 22.7.** The minimum thickness of a turbine rotor is 9 mm at a radius of 300 mm. If the rotor is to be designed for a uniform stress of 200 MN/m<sup>2</sup>, find the thickness of the rotor at a radius of 25 mm when it is running at 9000 r.p.m. Take  $\rho = 8000$  kg/m<sup>3</sup>.

**Sol.** Given :

Thickness,  $t_1 = 9$  mm when  $r_1 = 300$  mm = 0.3 m

Uniform stress,  $\sigma = 200$  MN/m<sup>2</sup> =  $200 \times 10^6$  N/m<sup>2</sup>

Density,  $\rho = 8000$  kg/m<sup>3</sup>

Speed,  $N = 9000$  r.p.m.

$\therefore$  Angular speed,  $\omega = \frac{2\pi N}{60} = \frac{2\pi \times 9000}{60} = 300\pi$  rad/s

Find thickness when radius = 25 mm = 0.025 m

Using equation (22.15), we get

$$t = C \times e^{-\frac{\rho \times \omega^2 \times r^2}{2\sigma}} \quad \dots(i)$$

(i) When  $t = 9$  mm ; radius,  $r = 300$  mm = 0.3 m

Hence above equation becomes,

$$9 = C \times e^{-\frac{\rho \times \omega^2 \times (0.3)^2}{2\sigma}}$$

$$= C \times e^{-\frac{\rho \times \omega^2 \times 0.09}{2\sigma}}$$

$$C = \frac{9}{e^{-\frac{\rho \times \omega^2 \times 0.09}{2\sigma}}}$$

$$= 9 \times e^{\frac{\rho \times \omega^2 \times 0.09}{2\sigma}} \quad \dots(ii)$$

(ii) When thickness is  $t$ , radius is 0.025 m

Substituting the above values in equation (i), we get

$$t = C \times e^{-\frac{\rho \times \omega^2 \times (0.025)^2}{2\sigma}}$$

$$= \left( 9 \times e^{\frac{\rho \times \omega^2 \times 0.09}{2\sigma}} \right) \times e^{-\frac{\rho \times \omega^2 \times 0.000625}{2\sigma}}$$

$$\left[ \therefore \text{From equation (ii), } C = 9 \times e^{\frac{\rho \times \omega^2 \times 0.09}{2\sigma}} \right]$$

$$\begin{aligned}
 &= 9 \times e \left( \frac{\rho \times \omega^2 \times 0.09}{2\sigma} - \frac{\rho \times \omega^2 \times 0.000625}{2\sigma} \right) \\
 &= 9 \times e \frac{\rho \times \omega^2 (0.09 - 0.000625)}{2\sigma} \\
 &= 9 \times e \frac{\rho \times \omega^2}{2\sigma} \times 0.089375 = 9 \times e \frac{8000 \times (300 \pi)^2 \times 0.089375}{2 \times 200 \times 10^6} \\
 &= 9 \times e^{1.587} = 9 \times 4.892 = 44.03 \text{ mm. Ans.}
 \end{aligned}$$

**22.4. LONG CYLINDERS**

In case of rotating long cylinders, it is assumed that the longitudinal strain ( $e_l$ ) even at high speeds of rotation is constant (this means that the cross-sections remain plane, which is true for the sections away from the ends.)

- Let  $\sigma_c$  = Circumferential (or hoop stress)
- $\sigma_r$  = Radial stress
- $\sigma_l$  = Longitudinal (or axial) stress
- $e_c$  = Circumferential strain
- $e_r$  = Radial strain,
- $e_l$  = Longitudinal strain.

When the cylinder rotates at high speeds, let the radius  $r$  becomes  $(r + u)$  and 'dr' becomes  $(dr + du)$ . Then circumferential strain,

$$e_c = \frac{2\pi(r + u) - 2\pi r}{2\pi r} = \frac{u}{r}$$

Radial strain, 
$$e_r = \frac{(dr + du) - dr}{dr} = \frac{du}{dr}$$

The stresses  $\sigma_c$ ,  $\sigma_r$  and  $\sigma_l$  are acting on any element of a section of the cylinder. The strains produced by these stresses in circumferential direction, radial direction and longitudinal direction are circumferential strain, radial strain and longitudinal strains respectively. These strains in terms of stresses are given by,

Circumferential strain, 
$$e_c = \frac{\sigma_c}{E} - \frac{\mu}{E} (\sigma_r + \sigma_l) = \frac{u}{r} \quad \dots(i)$$

Radial strain, 
$$e_r = \frac{\sigma_r}{E} - \frac{\mu}{E} (\sigma_c + \sigma_l) = \frac{du}{dr} \quad \dots(ii)$$

and longitudinal strain, 
$$e_l = \frac{\sigma_l}{E} - \frac{\mu}{E} (\sigma_r + \sigma_c) \quad \dots(iii)$$

where  $\mu$  = Poisson's ratio, and  $E$  = Young's modulus

In equations (i) and (ii),  $u$  is the increase of radius  $r$  due to rotation and  $du$  is the increase in thickness  $dr$ . These two values  $u$  and  $du$  are unknowns. They can be eliminated as given below :

From equation (i), we have

$$u = \frac{r}{E} [\sigma_c - \mu(\sigma_r + \sigma_l)]$$

or 
$$Eu = r [\sigma_c - \mu(\sigma_r + \sigma_l)]$$

Differentiating the above equation w.r.t.  $r$ , we get

$$E \frac{du}{dr} = [\sigma_c - \mu(\sigma_r + \sigma_l)] + r \left[ \frac{d\sigma_c}{dr} - \mu \left( \frac{d\sigma_r}{dr} + \frac{d\sigma_l}{dr} \right) \right] \quad \dots(iv)$$

But from equation (iii),

$$\frac{du}{dr} = \frac{\sigma_r}{E} - \frac{\mu}{E} (\sigma_c + \sigma_l)$$

or 
$$E \frac{du}{dr} = \sigma_r - \mu(\sigma_c + \sigma_l) \quad \dots(v)$$

Equating the two values of  $E \frac{du}{dr}$  given by equations (iv) and (v), we get

$$[\sigma_c - \mu(\sigma_r + \sigma_l)] + r \left[ \frac{d\sigma_c}{dr} - \mu \left( \frac{d\sigma_r}{dr} + \frac{d\sigma_l}{dr} \right) \right] = \sigma_r - \mu(\sigma_c + \sigma_l)$$

or 
$$\sigma_c - \mu\sigma_r - \mu\sigma_l + r \left[ \frac{d\sigma_c}{dr} - \mu \left( \frac{d\sigma_r}{dr} + \frac{d\sigma_l}{dr} \right) \right] = \sigma_r - \mu\sigma_c - \mu\sigma_l$$

$$\sigma_c (1 + \mu) - \sigma_r (1 + \mu) + r \left[ \frac{d\sigma_c}{dr} - \mu \left( \frac{d\sigma_r}{dr} + \frac{d\sigma_l}{dr} \right) \right] = 0$$

or 
$$(1 + \mu) (\sigma_c - \sigma_r) + r \left[ \frac{d\sigma_c}{dr} - \mu \left( \frac{d\sigma_r}{dr} + \frac{d\sigma_l}{dr} \right) \right] = 0 \quad \dots(vi)$$

In equation (vi), the value of  $\frac{d\sigma_l}{dr}$  should be substituted in terms of  $\sigma_c$  and  $\sigma_r$ . Now from equation (iii), we have

$$e_l = \frac{1}{E} [\sigma_l - \mu(\sigma_c + \sigma_r)]$$

or 
$$\sigma_l - \mu(\sigma_c + \sigma_r) = E \times e_l$$
  
 where  $e_l$  = longitudinal strain which is assumed constant.

To get the value of  $\frac{d\sigma_l}{dr}$ , differentiate the above equation w.r.t.  $r$ .

$$\frac{d\sigma_l}{dr} - \mu \left( \frac{d\sigma_c}{dr} + \frac{d\sigma_r}{dr} \right) = 0$$

[∵ Differentiation of a constant ( $E \times e_l$  is constant) is zero]

or 
$$\frac{d\sigma_l}{dr} = \mu \left( \frac{d\sigma_c}{dr} + \frac{d\sigma_r}{dr} \right)$$

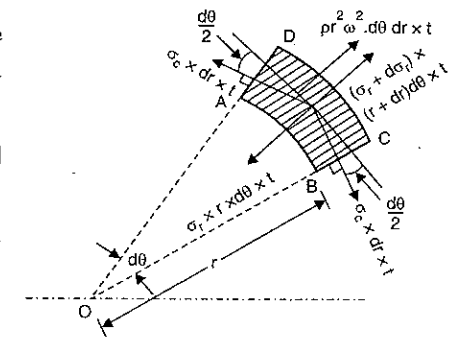

Fig. 22.9

Substituting this value of  $\frac{d\sigma_l}{dr}$  in equation (vi), we get

$$(1 + \mu)(\sigma_c - \sigma_r) + r \left[ \frac{d\sigma_c}{dr} - \mu \left\{ \frac{d\sigma_r}{dr} + \mu \left( \frac{d\sigma_c}{dr} + \frac{d\sigma_r}{dr} \right) \right\} \right] = 0$$

or

$$(1 + \mu)(\sigma_c - \sigma_r) + r \left[ \frac{d\sigma_c}{dr} - \mu \frac{d\sigma_r}{dr} - \mu^2 \frac{d\sigma_c}{dr} - \mu^2 \frac{d\sigma_r}{dr} \right] = 0$$

or

$$(1 + \mu)(\sigma_c - \sigma_r) + r \left[ (1 - \mu^2) \frac{d\sigma_c}{dr} - \mu \frac{d\sigma_r}{dr} (1 + \mu) \right] = 0$$

or

$$(1 + \mu)(\sigma_c - \sigma_r) + r(1 - \mu^2) \frac{d\sigma_c}{dr} - \mu \times r \frac{d\sigma_r}{dr} (1 + \mu) = 0$$

or

$$(1 + \mu)(\sigma_c - \sigma_r) + r(1 + \mu)(1 - \mu) \frac{d\sigma_c}{dr} - \mu \times r \times (1 + \mu) \frac{d\sigma_r}{dr} = 0$$

or

$$(\sigma_c - \sigma_r) + r(1 - \mu) \frac{d\sigma_c}{dr} - \mu \times r \times \frac{d\sigma_r}{dr} = 0 \quad \dots(vii)$$

[Cancelling  $(1 + \mu)$ ]

Now considering the equilibrium of an element  $ABCD$  of radius ' $r$ ', radial width  $dr$  and thickness ' $t$ ' subtending an angle  $d\theta$  at the centre as shown in Fig. 22.9, we get

$$\sigma_r \times rd\theta \times t + 2\sigma_c \times dr \times t \times \sin \frac{d\theta}{2} = (\sigma_r + d\sigma_r)(r + dr) d\theta \times t + \text{centrifugal force}$$

(Resolving the force in radial direction)

where centrifugal force =  $m \times \omega^2 \times r$  where  $m$  = mass of element  
 =  $\rho \times$  volume of element  
 =  $\rho \times (rd\theta \times dr \times t)$   
 =  $(\rho \times rd\theta \times dr \times t) \times \omega^2 \times r$   
 =  $\rho r^2 \times \omega^2 \times d\theta \times dr \times t$

and

$$\sin \frac{d\theta}{2} = \frac{d\theta}{2} \text{ as } d\theta \text{ is very small}$$

Hence the above equation becomes as

$$\sigma_r \times rd\theta \times t + 2\sigma_c \times dr \times t \times \frac{d\theta}{2} = (\sigma_r + d\sigma_r)(r + dr) d\theta \times t + \rho r^2 \omega^2 \times d\theta \times dr \times t$$

Cancelling  $d\theta \times t$  to both sides, we get

$$\sigma_r \times r + 2\sigma_c \times dr \times \frac{1}{2} = (\sigma_r + d\sigma_r)(r + dr) + \rho r^2 \omega^2 \times dr$$

or

$$\sigma_r \times r + \sigma_c \times dr = [\sigma_r \times r + \sigma_r \times dr + rd\sigma_r + (d\sigma_r) \times dr] + \rho r^2 \omega^2 \times dr$$

or

$$\sigma_c \times dr = \sigma_r \times dr + rd\sigma_r + \rho r^2 \omega^2 \times dr$$

[Neglecting the product of two small quantities i.e.,  $(d\sigma_r) \times dr$ ]

Dividing by  $dr$  to both sides, we get

$$\sigma_c = \sigma_r + r \frac{d\sigma_r}{dr} + \rho r^2 \omega^2$$

or

$$(\sigma_c - \sigma_r) = r \frac{d\sigma_r}{dr} + \rho r^2 \omega^2 \quad \dots(viii)$$

Substituting this value of  $(\sigma_c - \sigma_r)$  in equation (vii), we get

$$r \frac{d\sigma_r}{dr} + \rho r^2 \omega^2 + r(1 - \mu) \frac{d\sigma_c}{dr} - \mu \times r \times \frac{d\sigma_r}{dr} = 0$$

or

$$r \frac{d\sigma_r}{dr} (1 - \mu) + \rho r^2 \omega^2 + r(1 - \mu) \frac{d\sigma_c}{dr} = 0$$

or

$$r(1 - \mu) \left( \frac{d\sigma_r}{dr} + \frac{d\sigma_c}{dr} \right) + \rho r^2 \omega^2 = 0$$

or

$$\frac{d\sigma_r}{dr} + \frac{d\sigma_c}{dr} = - \frac{\rho r^2 \omega^2}{r(1 - \mu)} = - \frac{\rho \times r \times \omega^2}{(1 - \mu)}$$

Integrating both sides, we get

$$\sigma_r + \sigma_c = - \frac{\rho}{(1 - \mu)} \times \omega^2 \times \frac{r^2}{2} + C_1 \quad \dots(ix)$$

where  $C_1$  is a constant of integration.

To get the values of  $\sigma_r$  and  $\sigma_c$ , the two equations (ix) and (viii) are to be solved. As equation (viii) contains  $\frac{d\sigma_r}{dr}$ , we should eliminate  $\sigma_c$  from these equations. This can be done by subtracting equation (viii) from equation (ix), then we get

$$2\sigma_r = \left( - \frac{\rho}{(1 - \mu)} \times \omega^2 \times \frac{r^2}{2} + C_1 \right) - r \frac{d\sigma_r}{dr} - \rho r^2 \omega^2$$

or

$$2\sigma_r + r \frac{d\sigma_r}{dr} = - \frac{\rho}{(1 - \mu)} \times \omega^2 \times \frac{r^2}{2} - \rho r^2 \omega^2 + C_1$$

$$= - \frac{\rho \times \omega^2 \times r^2}{2} \left( \frac{1}{(1 - \mu)} + 2 \right) + C_1$$

$$= - \frac{\rho \times \omega^2 \times r^2}{2} \left( \frac{1 + 2 - 2\mu}{(1 - \mu)} \right) + C_1$$

$$= - \frac{\rho \times \omega^2 \times r^2}{2} \left( \frac{3 - 2\mu}{1 - \mu} \right) + C_1$$

Multiplying by  $r$  to both sides, we get

$$2r\sigma_r + r^2 \frac{d\sigma_r}{dr} = - \frac{\rho \times \omega^2 \times r^3}{2} \left( \frac{3 - 2\mu}{1 - \mu} \right) + C_1 r$$

or

$$\frac{d}{dr} (r^2 \times \sigma_r) = - \frac{\rho \times \omega^2 \times r^3}{2} \left( \frac{3 - 2\mu}{1 - \mu} \right) + C_1 r$$

Integrating the above equation, we get

$$r^2 \times \sigma_r = - \frac{\rho \times \omega^2 \times r^4}{2 \times 4} \left( \frac{3 - 2\mu}{1 - \mu} \right) + \frac{C_1 \times r^2}{2} + C_2$$

where  $C_2$  is another constant of integration.

$$\sigma_r = -\frac{\rho \times \omega^2 \times r^2}{8} \left( \frac{3-2\mu}{1-\mu} \right) + \frac{C_1}{2} + \frac{C_2}{r^2}$$

or

$$\sigma_r = \frac{C_1}{2} + \frac{C_2}{r^2} - \frac{\rho \times \omega^2 \times r^2}{8} \left( \frac{3-2\mu}{1-\mu} \right) \quad \dots(22.17)$$

The equation (22.17) gives the expression for radial stress set up in a rotating long cylinder. To get the expression for circumferential stress (*i.e.*,  $\sigma_c$ ), substitute the above value in equation (ix).

$$\therefore \left[ \frac{C_1}{2} + \frac{C_2}{r^2} - \frac{\rho \times \omega^2 \times r^2}{8} \frac{(3-2\mu)}{1-\mu} \right] + \sigma_c = -\frac{\rho}{(1-\mu)} \times \frac{\omega^2 \times r^2}{2} + C_1$$

$$\therefore \sigma_c = -\frac{\rho}{(1-\mu)} \times \frac{\omega^2 \times r^2}{2} + C_1 - \frac{C_1}{2} - \frac{C_2}{r^2} + \frac{\rho \times \omega^2 \times r^2}{8} \frac{(3-2\mu)}{1-\mu}$$

$$= \frac{C_1}{2} - \frac{C_2}{r^2} - \frac{\rho \times \omega^2 \times r^2}{8(1-\mu)} [4 - (3-2\mu)]$$

$$= \frac{C_1}{2} - \frac{C_2}{r^2} - \frac{\rho \times \omega^2 \times r^2}{8(1-\mu)} (1+2\mu)$$

or

$$\sigma_c = \frac{C_1}{2} - \frac{C_2}{r^2} - \frac{\rho \times \omega^2 \times r^2}{8} \left( \frac{1+2\mu}{1-\mu} \right) \quad \dots(22.18)$$

The equation (22.18), gives the expression for circumferential stress set up in a rotating long cylinder.

#### 22.4.1. Expression for Circumferential and Radial Stresses in a Solid Cylinder.

For a solid cylinder, at the centre  $r = 0$ , the stresses will become infinite. But the stresses cannot be infinite at the centre. Hence in equations (22.17) and (22.18), the constant  $C_2$  should be zero *i.e.*,  $C_2 = 0$ . Hence the stresses for solid cylinder will be as :

$$\sigma_r = \frac{C_1}{2} - \frac{\rho \times \omega^2 \times r^2}{8} \left( \frac{3-2\mu}{1-\mu} \right) \quad \dots(x)$$

and

$$\sigma_c = \frac{C_1}{2} - \frac{\rho \times \omega^2 \times r^2}{8} \left( \frac{1+2\mu}{1-\mu} \right) \quad \dots(xi)$$

The constant  $C_1$  from these equations will be obtained from boundary condition.

Now for a solid cylinder on the free surface,  $\sigma_r = 0$ . This means at  $r = r_2$

$\sigma_r = 0$  where  $r_2 =$  radius of the surface of the shaft.

From equation (x) in which  $\sigma_r = 0$  at  $r = r_2$ , we get

$$0 = \frac{C_1}{2} - \frac{\rho \times \omega^2 \times r_2^2}{8} \left( \frac{3-2\mu}{1-\mu} \right)$$

$$\frac{C_1}{2} = \frac{\rho \times \omega^2 \times r_2^2}{8} \left( \frac{3-2\mu}{1-\mu} \right)$$

Substituting the above value in equations (x) and (xi), we get

$$\sigma_r = \frac{\rho \times \omega^2 \times r_2^2}{8} \left( \frac{3-2\mu}{1-\mu} \right) - \frac{\rho \times \omega^2 \times r^2}{8} \left( \frac{3-2\mu}{1-\mu} \right)$$

$$= \frac{\rho \times \omega^2}{8} \left( \frac{3-2\mu}{1-\mu} \right) (r_2^2 - r^2) \quad \dots(22.19)$$

The stress is maximum at the centre where  $r = 0$

$$\therefore (\sigma_r)_{\max} = \frac{\rho \times \omega^2}{8} \left( \frac{3-2\mu}{1-\mu} \right) r_2^2$$

and

$$\sigma_c = \frac{\rho \times \omega^2 \times r_2^2}{8} \left( \frac{3-2\mu}{1-\mu} \right) - \frac{\rho \times \omega^2 \times r^2}{8} \left( \frac{1+2\mu}{1-\mu} \right)$$

$$= \frac{\rho \times \omega^2 \times r_2^2}{8} \left( \frac{3-2\mu}{1-\mu} \right) - \frac{\rho \times \omega^2 \times r^2}{8} \left( \frac{1+2\mu}{1-\mu} \right) \times \frac{(3-2\mu)}{(3-2\mu)}$$

[Multiply and divide the last term by  $(3-2\mu)$ ]

$$= \frac{\rho \times \omega^2}{8} \times \left( \frac{3-2\mu}{1-\mu} \right) \left[ r_2^2 - r^2 \left( \frac{1+2\mu}{3-2\mu} \right) \right]$$

$$= \frac{\rho \times \omega^2}{8} \times \left( \frac{3-2\mu}{1-\mu} \right) \left[ r_2^2 - \left( \frac{1+2\mu}{3-2\mu} \right) r^2 \right]$$

The stress is maximum at the centre where  $r = 0$

$$\therefore (\sigma_c)_{\max} = \frac{\rho \times \omega^2}{8} \left( \frac{3-2\mu}{1-\mu} \right) \frac{r_2^2}{2} \quad \dots(22.20)$$

Hence in case of solid cylinder, the circumferential and radial stresses are maximum at the centre and they are equal

$$\therefore (\sigma_r)_{\max} = (\sigma_c)_{\max} = \frac{\rho \times \omega^2}{8} \left( \frac{3-2\mu}{1-\mu} \right) \times r_2^2 \quad \dots(22.21)$$

#### 22.4.2. Expression for Circumferential and Radial Stresses in a Hollow Cylinder.

The circumferential and radial stresses in a rotating long cylinder are given by equations as

$$\sigma_c = \frac{C_1}{2} - \frac{C_2}{r^2} - \frac{\rho \times \omega^2 \times r^2}{8} \left( \frac{1+2\mu}{1-\mu} \right) \quad \dots(i)$$

and

$$\sigma_r = \frac{C_1}{2} + \frac{C_2}{r^2} - \frac{\rho \times \omega^2 \times r^2}{8} \left( \frac{3-2\mu}{1-\mu} \right) \quad \dots(ii)$$

The values of  $C_1$  and  $C_2$  are obtained from boundary conditions.

For hollow cylinders, at  $r = r_1$ ,  $\sigma_r = 0$  and also at  $r = r_2$ ,  $\sigma_r = 0$

Substituting these values, we get two equations as

$$0 = \frac{C_1}{2} + \frac{C_2}{r_1^2} - \frac{\rho \times \omega^2 \times r_1^2}{8} \left( \frac{3-2\mu}{1-\mu} \right) \quad [\text{Here } \sigma_r = 0 \text{ at } r = r_1] \quad \dots(iii)$$

$$0 = \frac{C_1}{2} + \frac{C_2}{r_2^2} - \frac{\rho \times \omega^2 \times r_2^2}{8} \left( \frac{3-2\mu}{1-\mu} \right) \quad [\text{Here } \sigma_r = 0 \text{ at } r = r_2] \quad \dots(iv)$$



To eliminate  $C_1$  from these equation, subtract equation (iv) from equation (iii),

$$\begin{aligned} 0 &= \frac{C_2}{r_1^2} - \frac{\rho \times \omega^2}{8} \times r_1^2 \times \frac{(3-2\mu)}{(1-\mu)} - \frac{C_2}{r_2^2} + \frac{\rho \times \omega^2}{8} \times r_2^2 \times \frac{(3-2\mu)}{(1-\mu)} \\ &= C_2 \left[ \frac{1}{r_1^2} - \frac{1}{r_2^2} \right] - \frac{\rho \times \omega^2}{8} \times \frac{(3-2\mu)}{(1-\mu)} [r_1^2 - r_2^2] \\ &= C_2 \frac{(r_2^2 - r_1^2)}{r_1^2 r_2^2} + \frac{\rho \times \omega^2}{8} \frac{(3-2\mu)}{(1-\mu)} (r_2^2 - r_1^2) \\ &= \frac{C_2}{r_1^2 r_2^2} + \frac{\rho \times \omega^2}{8} \frac{(3-2\mu)}{(1-\mu)} \quad \text{[Cancelling } (r_2^2 - r_1^2)] \end{aligned}$$

$$C_2 = -\frac{\rho \times \omega^2}{8} \frac{(3-2\mu)}{(1-\mu)} r_1^2 r_2^2$$

Substituting this value of  $C_2$  in equation (iii), we get the value of  $C_1$  as

$$\begin{aligned} 0 &= \frac{C_1}{2} + \frac{1}{r_1^2} \left[ -\frac{\rho \times \omega^2}{8} \frac{(3-2\mu)}{(1-\mu)} r_1^2 r_2^2 \right] - \frac{\rho \times \omega^2}{8} \times r_1^2 \times \frac{(3-2\mu)}{(1-\mu)} \\ &= \frac{C_1}{2} - \frac{\rho \times \omega^2}{8} \frac{(3-2\mu)}{(1-\mu)} r_2^2 - \frac{\rho \times \omega^2}{8} \times r_1^2 \times \frac{(3-2\mu)}{(1-\mu)} \end{aligned}$$

$$\begin{aligned} \frac{C_1}{2} &= \frac{\rho \times \omega^2}{8} \frac{(3-2\mu)}{(1-\mu)} r_2^2 + \frac{\rho \times \omega^2}{8} \times \frac{(3-2\mu)}{(1-\mu)} \times r_1^2 \\ &= \frac{\rho \times \omega^2}{8} \frac{(3-2\mu)}{(1-\mu)} [r_2^2 + r_1^2] \end{aligned}$$

$$C_1 = \frac{\rho \times \omega^2}{4} \frac{(3-2\mu)}{(1-\mu)} [r_1^2 + r_2^2]$$

Substituting the values of  $C_1$  and  $C_2$  in equations (i) and (ii), we get

$$\begin{aligned} \sigma_c &= \frac{\rho \times \omega^2}{2 \times 4} \frac{(3-2\mu)}{(1-\mu)} (r_1^2 + r_2^2) - \left[ -\frac{\rho \times \omega^2}{8} \frac{(3-2\mu)}{(1-\mu)} \frac{r_1^2 r_2^2}{r^2} \right] - \frac{\rho \times \omega^2 \times r^2}{8} \frac{(1+2\mu)}{(1-\mu)} \\ &= \frac{\rho \times \omega^2}{8} \frac{(3-2\mu)}{(1-\mu)} [r_1^2 + r_2^2] + \frac{\rho \times \omega^2}{8} \frac{(3-2\mu)}{(1-\mu)} \times \frac{r_1^2 \times r_2^2}{r^2} - \frac{\rho \times \omega^2 \times r^2}{8} \frac{(1+2\mu)}{(1-\mu)} \\ &= \frac{\rho \times \omega^2}{8} \frac{(3-2\mu)}{(1-\mu)} (r_1^2 + r_2^2) + \frac{\rho \times \omega^2}{8} \frac{(3-2\mu)}{(1-\mu)} \left[ \frac{r_1^2 - r_2^2}{r^2} - \frac{1+2\mu}{3-2\mu} r^2 \right] \\ &= \frac{\rho \times \omega^2}{8} \frac{(3-2\mu)}{(1-\mu)} \left[ r_1^2 + r_2^2 + \frac{r_1^2 - r_2^2}{r^2} - \frac{(1+2\mu)}{(3-2\mu)} r^2 \right] \quad \dots(22.22) \end{aligned}$$

$$\begin{aligned} \text{and } \sigma_r &= \frac{\rho \times \omega^2}{2 \times 4} \frac{(3-2\mu)}{(1-\mu)} (r_1^2 + r_2^2) + \left[ -\frac{\rho \times \omega^2}{8} \times \frac{(3-2\mu)}{(1-\mu)} \frac{r_1^2 \times r_2^2}{r^2} \right] - \frac{\rho \times \omega^2 \times r^2}{8} \times \frac{(3-2\mu)}{(1-\mu)} \\ &= \frac{\rho \times \omega^2}{8} \frac{(3-2\mu)}{(1-\mu)} \left[ r_1^2 + r_2^2 - \frac{r_1^2 \times r_2^2}{r^2} - r^2 \right] \quad \dots(22.23) \end{aligned}$$

Equation (22.22) gives the expression for circumferential stress and equation (22.23) gives the expression for radial stress in a hollow long rotating cylinder.

#### Maximum circumferential stress ( $\sigma_c$ )<sub>max</sub>

From equation (22.22), it is clear that circumferential stress will be maximum when 'r' is minimum.

Hence circumferential stress will be maximum at the inner radius where 'r' is minimum (i.e.,  $r = r_1$ )

Hence substituting  $r = r_1$  in equation (22.22), we get max. value of  $\sigma_c$

$$\begin{aligned} \therefore (\sigma_c)_{\max} &= \frac{\rho \times \omega^2}{8} \frac{(3-2\mu)}{(1-\mu)} \left[ r_1^2 + r_2^2 + \frac{r_1^2 \times r_2^2}{r_1^2} - \frac{(1+2\mu)}{(3-2\mu)} r_1^2 \right] \\ &= \frac{\rho \times \omega^2}{8} \times \frac{(3-2\mu)}{(1-\mu)} \left[ r_1^2 + 2r_2^2 - \frac{(1+2\mu)}{(3-2\mu)} r_1^2 \right] \quad \dots(22.24) \end{aligned}$$

#### Maximum radial stress ( $\sigma_r$ )<sub>max</sub>

From equation (22.23), we cannot say that  $\sigma_r$  will be maximum when  $r$  is minimum.

Hence for  $\sigma_r$  to be maximum  $\frac{d(\sigma_r)}{dr}$  should be zero.

$$\text{or } \frac{d}{dr} \left[ \frac{\rho \times \omega^2}{8} \frac{(3-2\mu)}{(1-\mu)} \left[ r_1^2 + r_2^2 - \frac{r_1^2 \times r_2^2}{r^2} - r^2 \right] \right] = 0$$

$$\text{or } \frac{\rho \times \omega^2}{8} \frac{(3-2\mu)}{(1-\mu)} \left[ 0 + 0 - \frac{r_1^2 \times r_2^2 \times (-2)}{r^3} - 2r \right] = 0$$

$$\text{or } + \frac{2r_1^2 \times r_2^2}{r^3} - 2r = 0$$

$$\text{or } 2r_1^2 \times r_2^2 - 2r^4 = 0$$

$$\text{or } r^4 = r_1^2 \times r_2^2 \quad \text{or } r^2 = r_1 \times r_2$$

$$\text{or } r = \sqrt{r_1 \times r_2} \quad \dots(22.25)$$

Equation (22.25) gives the value of  $r$  at which radial stress will be maximum. Substituting this value of 'r' in equation (22.23), we get maximum value of radial stress.

$$\begin{aligned} \therefore (\sigma_r)_{\max} &= \frac{\rho \times \omega^2}{8} \frac{(3-2\mu)}{(1-\mu)} \left[ r_1^2 + r_2^2 - \frac{r_1^2 \times r_2^2}{r_1 \times r_2} - r_1 r_2 \right] \\ &= \frac{\rho \times \omega^2}{8} \frac{(3-2\mu)}{(1-\mu)} [r_1^2 + r_2^2 - 2r_1 r_2] = \frac{\rho \times \omega^2}{8} \frac{(3-2\mu)}{(1-\mu)} [r_2 - r_1]^2 \quad \dots(22.26) \end{aligned}$$

Equation (22.26) gives the value of maximum radial stress.

**Problem 22.8.** A long cylinder is rotating at a speed of 3600 r.p.m. The diameter of the cylinder is 500 mm and density of its material is 8000 kg/m<sup>3</sup>. If Poisson's ratio = 0.3, then :

- (i) Calculate the maximum stress in the cylinder and
- (ii) Plot the circumferential stress and radial stress along the radius.

**Sol.** Given :

Diameter,  $d_2 = 500 \text{ mm}$

∴ Radius,  $r_2 = \frac{d_2}{2} = \frac{500}{2} = 250 \text{ mm} = 0.25 \text{ m}$

Speed of rotation,  $N = 3600 \text{ r.p.m.}$

∴ Angular speed,  $\omega = \frac{2\pi N}{60} = \frac{2\pi \times 3600}{60} = 120 \pi \text{ rad/s}$

Density,  $\rho = 8000 \text{ kg/m}^3$ , Poisson's ratio,  $\mu = 0.3$

(i) *Maximum stress in the cylinder.* Maximum circumferential and radial stresses occur at the centre, where  $r = 0$ . It is given by equation (22.21) as

$$\begin{aligned}
 (\sigma_c)_{\max} = (\sigma_r)_{\max} &= \frac{\rho \times \omega^2 \times r_2^2}{8} \left( \frac{3 - 2\mu}{1 - \mu} \right) \\
 &= \frac{8000 \times (120 \pi)^2 \times (0.25)^2}{8} \left( \frac{3 - 2 \times 0.3}{1 - 0.3} \right) \\
 &= \frac{8000 \times 14400 \times \pi^2 \times 0.0625}{8} \times \frac{2.4}{0.7} \text{ N/m}^2 \\
 &= 30.45 \times 10^6 \text{ N/m}^2 = \mathbf{30.45 \text{ MN/m}^2}. \text{ Ans.}
 \end{aligned}$$

(ii) *Plot of the stresses :*

*Circumferential stress ( $\sigma_c$ ):* Circumferential stress is given by equation (22.20), as

$$\begin{aligned}
 \sigma_c &= \frac{\rho \times \omega^2}{8} \left( \frac{3 - 2\mu}{1 - \mu} \right) \left[ r_2^2 - \left( \frac{1 + 2\mu}{3 - 2\mu} \right) r^2 \right] \\
 &= \frac{8000 \times (120 \pi)^2}{8} \left( \frac{3 - 2 \times 0.3}{1 - 0.3} \right) \left[ 0.25^2 - \left( \frac{1 + 2 \times 0.3}{3 - 2 \times 0.3} \right) r^2 \right] \\
 &= \frac{8000 \times 14400 \times \pi^2}{8} \times \frac{2.4}{0.7} \left[ 0.0625 - \frac{1.6}{2.4} r^2 \right] \\
 &= 4.872 \times 10^8 [0.0625 - 0.667 r^2] \text{ N/m}^2 \\
 &= 487.2 \times 10^6 [0.0625 - 0.667 r^2] \text{ N/m}^2 \\
 &= 487.2 (0.0625 - 0.667 r^2) \text{ MN/m}^2
 \end{aligned}$$

When  $r = 0$ ,  $\sigma_c = 487.2 \times 0.0625 \text{ MN/m}^2 = 30.45 \text{ MN/m}^2$   
 $r = 0.05 \text{ m}$ ,  $\sigma_c = 487.2 (0.0625 - 0.667 \times 0.05^2) = 29.63 \text{ MN/m}^2$   
 $r = 0.10 \text{ m}$ ,  $\sigma_c = 487.2 (0.0625 - 0.667 \times 0.1^2) = 27.2 \text{ MN/m}^2$   
 $r = 0.15 \text{ m}$ ,  $\sigma_c = 487.2 (0.0625 - 0.667 \times 0.15^2) = 23.14 \text{ MN/m}^2$   
 $r = 0.20 \text{ m}$ ,  $\sigma_c = 487.2 (0.0625 - 0.667 \times 0.2^2) = 17.45 \text{ MN/m}^2$   
 $r = 0.25 \text{ m}$ ,  $\sigma_c = 487.2 (0.0625 - 0.667 \times 0.25^2) = 10.14 \text{ MN/m}^2$

*Radial stress*

Radial stress is given by equation (22.19),

$$\begin{aligned}
 \sigma_r &= \frac{\rho \times \omega^2 (r_2^2 - r^2)}{8} \left[ \frac{3 - 2\mu}{1 - \mu} \right] \\
 &= \frac{8000 \times (120 \pi)^2}{8} (0.25^2 - r^2) \left( \frac{3 - 2 \times 0.3}{1 - 0.3} \right) \\
 &= 1000 \times 14400 \times \pi^2 (0.0625 - r^2) \left( \frac{2.4}{0.7} \right) \\
 &= 1000 \times 14400 \times \pi^2 \times \frac{2.4}{0.7} (0.0625 - r^2) \\
 &= 487.276 \times 10^6 (0.0625 - r^2) \\
 &= 487.276 (0.0625 - r^2) \text{ MN/m}^2
 \end{aligned}$$

When  $r = 0$ ,  $\sigma_r = 487.276 (0.0625) = 30.45 \text{ MN/m}^2$   
 $r = 0.05 \text{ m}$ ,  $\sigma_r = 487.276 (0.0625 - 0.05^2) = 29.88$   
 $r = 0.1 \text{ m}$ ,  $\sigma_r = 487.276 (0.0625 - 0.1^2) = 25.58$   
 $r = 0.15 \text{ m}$ ,  $\sigma_r = 487.276 (0.0625 - 0.15^2) = 19.49$   
 $r = 0.20 \text{ m}$ ,  $\sigma_r = 487.276 (0.0625 - 0.2^2) = 10.96$   
 $r = 0.25 \text{ m}$ ,  $\sigma_r = 487.276 (0.0625 - 0.25^2) = 0$

The variation of circumferential and radial stresses are shown in Fig. 29.10, in which stresses are along x-axis and radius along y-axis.

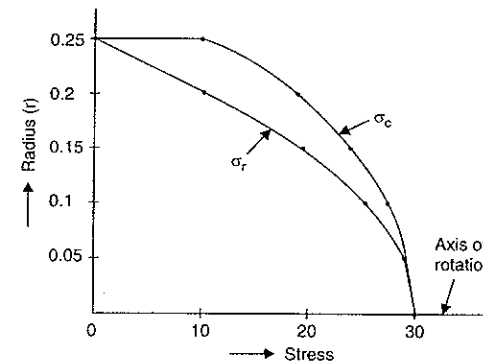

Fig. 22.10

Fig. 29.11 shows the variation of these stresses when radius is taken along x-axis and stresses along y-axis.

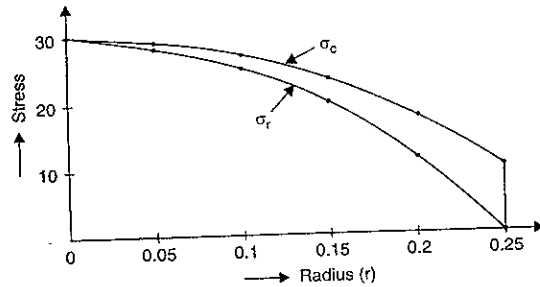

Fig. 22.11

**Problem 22.9.** If in Problem 22.8, the long rotating cylinder is having a central hole of diameter 200 mm, then determine :

- Maximum circumferential stress
- Radius at which radial stress is maximum,
- Maximum radial stress,
- The variation of circumferential and radial stresses along the radius of the cylinder.

Take all other data from Problem 22.8.

**Sol.** Given :

Outer diameter = 500 mm  $\therefore$  Outer radius,  $r_2 = 250 \text{ mm} = 0.25 \text{ m}$

Inner diameter = 200 mm  $\therefore$  Inner radius,  $r_1 = 100 \text{ mm} = 0.1 \text{ m}$

Speed,  $N = 3600 \text{ r.p.m}$  ;  $\omega = 120 \pi \text{ rad/s}$  ;  $\rho = 8000 \text{ kg/m}^3$ ,  $\mu = 0.3$

(i) **Maximum circumferential stress  $(\sigma_c)_{\max}$ .** The circumferential stress at any radius is given by equation (22.22) as

$$\sigma_c = \frac{\rho \times \omega^2}{8} \left( \frac{3 - 2\mu}{1 - \mu} \right) \left[ r_1^2 + r_2^2 + \frac{r_1^2 r_2^2}{r^2} - \left( \frac{1 + 2\mu}{3 - 2\mu} \right) r^2 \right]$$

The maximum circumferential stress occurs where radius ' $r$ ' is minimum. Hence at the inner radius (i.e., at  $r = r_1$ ), the circumferential stress will be maximum,

$$\begin{aligned} \therefore (\sigma_c)_{\max} &= \frac{\rho \times \omega^2}{8} \left( \frac{3 - 2\mu}{1 - \mu} \right) \left[ r_1^2 + r_2^2 + \frac{r_1^2 r_2^2}{r_1^2} - \left( \frac{1 + 2\mu}{3 - 2\mu} \right) r_1^2 \right] \\ &= \frac{\rho \times \omega^2}{8} \left( \frac{3 - 2\mu}{1 - \mu} \right) \left[ r_1^2 + 2r_2^2 - \left( \frac{1 + 2\mu}{3 - 2\mu} \right) r_1^2 \right] \\ &= \frac{8000 \times (120 \pi)^2}{8} \left( \frac{3 - 2 \times 0.3}{1 - 0.3} \right) \left[ 0.1^2 + 2 \times (0.25)^2 - \left( \frac{1 + 2 \times 0.3}{3 - 2 \times 0.3} \right) \times 0.1^2 \right] \\ &= 487.2 \times 10^6 \left[ 0.01 + 0.1250 - \frac{1.6}{2.4} \times 0.1^2 \right] \\ &= 62.5 \times 10^6 \text{ N/m}^2 = 62.5 \text{ MN/m}^2. \text{ Ans.} \end{aligned}$$

(ii) **Radius at which radial stress is maximum.** The radial stress is maximum at radius given by,

$$r = \sqrt{r_1 \times r_2} = \sqrt{0.1 \times 0.25} = 0.158 \text{ m}$$

(iii) **Maximum radial stress.** Maximum radial stress is given by equation (22.26) as

$$\begin{aligned} (\sigma_r)_{\max} &= \frac{\rho \times \omega^2}{8} \left( \frac{3 - 2\mu}{1 - \mu} \right) (r_2 - r_1)^2 \\ &= \frac{8000 \times (120 \pi)^2}{8} \times \left( \frac{3 - 2 \times 0.3}{1 - 0.3} \right) (0.25 - 0.1)^2 \\ &= 487.2 \times 10^6 \times 0.0225 = 10.962 \times 10^6 \text{ N/m}^2 \\ &= 10.962 \text{ MN/m}^2. \text{ Ans.} \end{aligned}$$

(iv) **Variation of stresses along the radius**

(a) **Circumferential stress  $(\sigma_c)$ .** The circumferential stress at any radius is given by equation (22.22) as

$$\begin{aligned} \sigma_c &= \frac{\rho \times \omega^2}{8} \left( \frac{3 - 2\mu}{1 - \mu} \right) \left[ r_1^2 + r_2^2 + \frac{r_1^2 r_2^2}{r^2} - \left( \frac{1 + 2\mu}{3 - 2\mu} \right) r^2 \right] \\ &= \frac{8000 \times (120 \pi)^2}{8} \left( \frac{3 - 2 \times 0.3}{1 - 0.3} \right) \left[ 0.1^2 + 0.25^2 + \frac{0.1^2 \times 0.25^2}{r^2} - \left( \frac{1 + 2 \times 0.3}{3 - 2 \times 0.3} \right) r^2 \right] \\ &= 487.2 \times 10^6 \times \left[ 0.01 + 0.0625 + \frac{0.000625}{r^2} - 0.667 \times r^2 \right] \text{ N/m}^2 \\ &= 487.2 \times \left( 0.0725 + \frac{0.000625}{r^2} - 0.667 \times r^2 \right) \text{ MN/m}^2 \end{aligned}$$

By substituting the different values of ' $r$ ' in the above equation, we get different values of  $\sigma_c$ . Let us start the calculation from inner radius (i.e.,  $r = r_1 = 0.1$ )

$$\text{At } r = 0.1, \quad \sigma_c = 487.2 \left[ 0.0725 + \frac{0.000625}{0.1^2} - 0.667 \times 0.1^2 \right] = 62.5 \text{ MN/m}^2$$

$$\begin{aligned} \text{At } r = 0.125, \quad \sigma_c &= 487.2 \left[ 0.0725 + \frac{0.000625}{0.125^2} - 0.667 \times 0.125^2 \right] \\ &= 487.2 [0.0725 + 0.04 - 0.0104] = 49.73 \text{ MN/m}^2 \end{aligned}$$

$$\begin{aligned} \text{At } r = 0.15, \quad \sigma_c &= 487.2 \left[ 0.0725 + \frac{0.000625}{0.15^2} - 0.667 \times 0.15^2 \right] \\ &= 487.2 [0.0725 + 0.0277 - 0.015] = 41.5 \text{ MN/m}^2 \end{aligned}$$

$$\begin{aligned} \text{At } r = 0.175, \quad \sigma_c &= 487.2 \left[ 0.0725 + \frac{0.000625}{0.175^2} - 0.667 \times 0.175^2 \right] \\ &= 487.2 [0.0725 + 0.0204 - 0.0204] = 35.32 \text{ MN/m}^2 \end{aligned}$$

$$\begin{aligned} \text{At } r = 0.2, \quad \sigma_c &= 487.2 \left[ 0.0725 + \frac{0.000625}{0.2^2} - 0.667 \times 0.2^2 \right] \\ &= 487.2 [0.0725 + 0.0156 - 0.02668] = 29.92 \text{ MN/m}^2 \end{aligned}$$

$$\begin{aligned} \text{At } r = 0.225, \quad \sigma_c &= 487.2 \left[ 0.0725 + \frac{0.000625}{0.225^2} - 0.667 \times 0.225^2 \right] \\ &= 487.2 [0.0725 + 0.0123 - 0.0337] = 24.86 \text{ MN/m}^2 \end{aligned}$$

$$\begin{aligned} \text{At } r = 0.25, \quad \sigma_c &= 487.2 \left[ 0.0725 + \frac{0.000625}{0.25^2} - 0.667 \times 0.25^2 \right] \\ &= 487.2 [0.0725 + 0.01 - 0.04168] = 19.88 \text{ MN/m}^2 \end{aligned}$$

(b) Radial Stress ( $\sigma_r$ ). The radial stress at any radius 'r' is given by equation (22.23) as

$$\begin{aligned} \sigma_r &= \frac{\rho \times \omega^2}{8} \times \left( \frac{3 - 2\mu}{1 - \mu} \right) \left[ r_1^2 + r_2^2 - \frac{r_1^2 r_2^2}{r^2} - r^2 \right] \\ &= \frac{8000 \times (120 \pi)^2}{8} \times \left( \frac{3 - 2 \times 0.3}{1 - 0.3} \right) \left[ 0.1^2 + 0.25^2 - \frac{0.1^2 \times 0.25^2}{r^2} - r^2 \right] \\ &= 487.2 \times 10^6 \times \left[ 0.01 + 0.0625 - \frac{0.000625}{r^2} - r^2 \right] \text{ N/m}^2 \\ &= 487.2 \times \left[ 0.0725 - \frac{0.000625}{r^2} - r^2 \right] \text{ MN/m}^2 \end{aligned}$$

By substituting the different values of 'r' in the above equation, we get different values of  $\sigma_r$ . Also  $\sigma_r$  is zero at  $r = 0.1$  m and  $r = 0.25$  m.

$$\text{At } r = 0.1 \text{ m, } \sigma_r = 0$$

$$\begin{aligned} \text{At } r = 0.125 \text{ m, } \sigma_r &= 487.2 \times \left[ 0.0725 - \frac{0.000625}{0.125^2} - 0.125^2 \right] \\ &= 487.2 \times [0.0725 - 0.04 - 0.0156] = 8.23 \text{ MN/m}^2 \end{aligned}$$

$$\begin{aligned} \text{At } r = 0.15 \text{ m, } \sigma_r &= 487.2 \times \left[ 0.0725 - \frac{0.000625}{0.15^2} - 0.15^2 \right] \\ &= 487.2 [0.0725 - 0.0277 - 0.0225] = 10.86 \text{ MN/m}^2 \end{aligned}$$

We have already calculated that  $\sigma_r$  is maximum at  $r = 0.158$  m and maximum value of  $\sigma_r$  is 10.962 MN/m<sup>2</sup>

$$\therefore \text{At } r = 0.158 \text{ m, } \sigma_r = 10.962 \text{ MN/m}^2$$

$$\begin{aligned} \text{At } r = 0.175 \text{ m, } \sigma_r &= 487.2 \left[ 0.0725 - \frac{0.000625}{0.175^2} - 0.175^2 \right] \\ &= 487.2 \times [0.0725 - 0.0204 - 0.0306] = 10.47 \text{ MN/m}^2 \end{aligned}$$

$$\begin{aligned} \text{At } r = 0.2 \text{ m, } \sigma_r &= 487.2 \left[ 0.0725 - \frac{0.000625}{0.2^2} - 0.2^2 \right] \\ &= 487.2 [0.0725 - 0.0156 - 0.04] = 8.23 \text{ MN/m}^2 \end{aligned}$$

$$\begin{aligned} \text{At } r = 0.225 \text{ m, } \sigma_r &= 487.2 \left[ 0.0725 - \frac{0.000625}{0.225^2} - 0.225^2 \right] \\ &= 487.2 [0.0725 - 0.0123 - 0.0506] = 4.66 \text{ MN/m}^2 \end{aligned}$$

$$\text{At } r = 0.25 \text{ m, } \sigma_r = 0$$

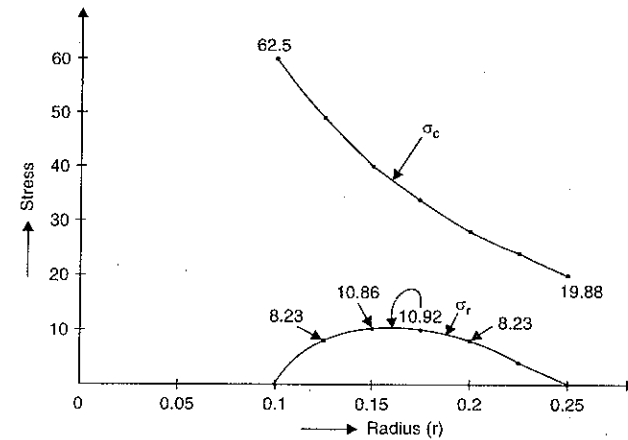

Fig.22.12

The variation of circumferential and radial stresses are shown in Fig. 22.12.

**HIGHLIGHTS**

1. The hoop stress (or circumferential stress) in a rotating thin cylinder is given by

$$\sigma = \rho \times \omega^2 \times r^2 \quad \text{or} \quad \rho \times v^2.$$

2. For a rotating solid disc, the stresses at any radius r are :

$$\sigma_c = \frac{\rho \times \omega^2}{8} [(3 + \mu) r_2^2 - (1 + 3\mu) r^2]$$

and

$$\sigma_r = \frac{\rho \times \omega^2}{8} (3 + \mu) [r_2^2 - r^2]$$

where  $\sigma_c$  = Circumferential stress,

$\sigma_r$  = Radial stress,

$$\omega = \text{Angular velocity} = \frac{2\pi N}{60}$$

$\mu$  = Poisson's ratio.

3. At the centre of rotating solid disc, the radial and circumferential stress are maximum and are equal.

$$(\sigma_r)_{\max} = (\sigma_c)_{\max} = \frac{\rho \times \omega^2}{8} (3 + \mu) r_2^2.$$

4. The circumferential stress at outer radius of a solid disc is given by

$$\sigma_c = \frac{\rho \times \omega^2 \times r_2^2}{4} (1 - \mu).$$

5. For a rotating disc with a central hole :

(i) The stresses at any radius are :

$$\sigma_r = \frac{\rho \times \omega^2}{8} (3 + \mu) \left[ (r_1^2 + r_2^2) - \frac{r_1^2 r_2^2}{r^2} - r^2 \right]$$

and

$$\sigma_c = \frac{\rho \times \omega^2}{8} (3 + \mu) \left[ (r_1^2 + r_2^2) + \frac{r_1^2 r_2^2}{r^2} - \left( \frac{1 + 3\mu}{3 + \mu} \right) r^2 \right]$$

(ii) The circumferential stress is maximum at inner radius and is given by

$$(\sigma_c)_{\max} = \frac{\rho \times \omega^2}{4} (3 + \mu) \left[ r_2^2 + \left( \frac{1 - \mu}{3 + \mu} \right) r_1^2 \right]$$

(iii) The radial stress is maximum at the radius given by

$$r = \sqrt{r_1 \times r_2}$$

(iv) The maximum radial stress is given by

$$(\sigma_r)_{\max} = \frac{\rho \times \omega^2}{8} (3 + \mu) [(r_2 - r_1)^2]$$

(v) The value of  $\sigma_c$  at the outer radius is

$$(\sigma_c)_{\text{at } r=r_2} = \frac{\rho \times \omega^2}{4} (3 + \mu) \left[ r_1^2 + \left( \frac{1 + \mu}{3 + \mu} \right) r_2^2 \right]$$

6. The maximum radial and circumferential stresses in a disc with pin hole at the centre are :

$$(\sigma_r)_{\max} = \frac{\rho \times \omega^2 \times r_2^2}{8} (3 + \mu)$$

and

$$(\sigma_c)_{\max} = \frac{\rho \times \omega^2 \times r_2^2}{4} (3 + \mu)$$

7. The maximum circumferential stress in a disc with a pin hole at the centre is two times the maximum circumferential stress in a solid disc.

8. A disc which has equal values of  $\sigma_c$  and  $\sigma_r$  at all radii, is known as a disc of uniform strength.

$\therefore \sigma_r = \sigma_c = \sigma$  for all radii.

9. The thickness of a disc of uniform strength is given by

$$t = t_0 e^{-\frac{\rho \times \omega^2 \times r^2}{2\sigma}}$$

where  $t_0$  = Thickness at  $r = 0$ .

10. For a rotating solid long cylinder :

(i) stresses at any radius are

$$\sigma_c = \frac{\rho \times \omega^2}{8} \left( \frac{3 - 2\mu}{1 - \mu} \right) \left[ r_2^2 - \left( \frac{1 + 2\mu}{3 - 2\mu} \right) r^2 \right]$$

and

$$\sigma_r = \frac{\rho \times \omega^2}{8} \left( \frac{3 - 2\mu}{1 - \mu} \right) [r_2^2 - r^2]$$

(ii)  $\sigma_r$  is maximum at the centre and is given by

$$(\sigma_r)_{\max} = \frac{\rho \times \omega^2}{8} \left( \frac{3 - 2\mu}{1 - \mu} \right) \times r_2^2$$

(iii)  $\sigma_c$  is maximum at the centre and is given by

$$(\sigma_c)_{\max} = \frac{\rho \times \omega^2}{8} \left( \frac{3 - 2\mu}{1 - \mu} \right) \times r_2^2$$

$$(iv) \quad (\sigma_r)_{\max} = (\sigma_c)_{\max} = \frac{\rho \times \omega^2}{8} \left( \frac{3 - 2\mu}{1 - \mu} \right) \times r_2^2$$

11. For a rotating hollow cylinder :

(i) The stresses at any radius are :

$$\sigma_c = \frac{\rho \times \omega^2}{8} \left( \frac{3 - 2\mu}{1 - \mu} \right) \left[ r_1^2 + r_2^2 + \frac{r_1^2 r_2^2}{r^2} - \left( \frac{1 + 2\mu}{3 - 2\mu} \right) r^2 \right]$$

$$\sigma_r = \frac{\rho \times \omega^2}{8} \left( \frac{3 - 2\mu}{1 - \mu} \right) \left[ r_1^2 + r_2^2 - \frac{r_1^2 r_2^2}{r^2} - r^2 \right]$$

(ii)  $\sigma_c$  will be maximum at inner radius and is equal to

$$(\sigma_c)_{\max} = \frac{\rho \times \omega^2}{8} \left( \frac{3 - 2\mu}{1 - \mu} \right) \left[ r_1^2 + 2r_2^2 - \left( \frac{1 + 2\mu}{3 - 2\mu} \right) r_1^2 \right]$$

(iii)  $\sigma_r$  is maximum at  $r = \sqrt{r_1 \times r_2}$  and is given by

$$(\sigma_r)_{\max} = \frac{\rho \times \omega^2}{8} \left( \frac{3 - 2\mu}{1 - \mu} \right) [(r_2 - r_1)^2]$$

### EXERCISE 22

#### (A) Theoretical Questions

1. Find an expression for the circumferential stress developed in a thin rotating cylinder.
2. Find an expression for the circumferential and radial stresses developed in a rotating solid disc.
3. Prove that the circumferential and radial stresses are maximum and are equal at the centre of a rotating solid disc.
4. Prove that the circumferential stress at the outer radius of a rotating solid disc is given by

$$\sigma_c = \frac{\rho \times \omega^2 \times r_2^2}{4} (1 - \mu)$$

5. Prove that the radius at which radial stress is maximum in a rotating disc with a central hole is given by

$$r = \sqrt{r_1 \times r_2}$$

Also find an expression for the maximum radial stress.

6. Prove that the circumferential stress in a rotating disc with a pin hole at the centre is two times the maximum circumferential stress in a rotating solid disc.
7. What do you mean by a disc of uniform strength? Find an expression for the thickness of a disc of uniform strength.
8. Prove that in case of a long solid rotating cylinder the maximum radial and circumferential stresses at the centre are equal and they are  $\frac{\rho \times \omega^2}{8} \left( \frac{3 - 2\mu}{1 - \mu} \right) \times r_2^2$  in magnitude.

9. Prove that in case of a rotating hollow cylinder, the radial stress is maximum at radius =  $\sqrt{r_1 \times r_2}$  and is given by

$$(\sigma_r)_{\max} = \frac{\rho \times \omega^2}{8} \left( \frac{3 - 2\mu}{1 - \mu} \right) [(r_2 - r_1)^2]$$

10. Prove that the thickness of a disc of uniform strength is given by

$$t = t_0 e^{-\frac{\rho \times \omega^2 \times r^2}{2\sigma}}$$

where  $t_0$  = Thickness at  $r = 0$

$\sigma$  = Stress developed due to rotation.

### (B) Numerical Problems

- Find the hoop stress developed in the thin rim of a wheel of radius 400 mm, when it is rotating at a speed of 3000 r.p.m. The density of the material of wheel is 8000 kg/m<sup>3</sup>.  
[Ans. 126.33 MN/m<sup>2</sup>]
- A steel disc of uniform thickness and diameter 900 mm is rotating about its axis at 2400 r.p.m. Determine :  
(i) radial and circumferential stresses at the centre, and  
(ii) circumferential stress at the outer radius.  
Take  $\rho = 7800$  kg/m<sup>3</sup> and Poisson's ratio = 0.3 [Ans. (i) 41.152 MN/m<sup>2</sup> (ii) 17.46 MN/m<sup>2</sup>]
- If for the question 2, the disc is having a central hole of 200 mm diameter, then determine :  
(i) circumferential stress at inner radius and outer radius.  
(ii) radius at which radial stress is maximum and  
(iii) maximum radial stress  
(iv) maximum shear stress.  
[Ans. (i) 82.16 MN/m<sup>2</sup>, 21.5 MN/m<sup>2</sup>, (ii) 0.212 m, (iii) 24.89 MN/m<sup>2</sup>, (iv) 41.58 MN/m<sup>2</sup>]
- For the data given in question 2, plot the variation of circumferential and radial stresses along the radius.
- For the data given in question 3, plot the variation of circumferential and radial stresses along the radius.
- A steam turbine rotor is running at 4800 r.p.m. It is to be designed for uniform strength for a stress of 90 MN/m<sup>2</sup>. If the thickness of the rotor at the centre is 30 mm and density of its material is 8000 kg/m<sup>3</sup>, find the thickness of the rotor at a radius of 400 mm. [Ans. 5 mm]
- The minimum thickness of a turbine rotor is 10 mm at a radius of 300 mm. If the rotor is to be designed for a uniform stress of 150 MN/m<sup>2</sup>, find the thickness of the rotor at a radius of 30 mm, when it is running at 8400 r.p.m. Take  $\rho = 8000$  kg/m<sup>3</sup>. [Ans. 62.84 mm]
- A long cylinder is rotating at a speed of 4200 r.p.m. The diameter of the cylinder is 400 mm and density of its material is 7800 kg/m<sup>3</sup>. If Poisson's ratio = 0.3, then  
(i) calculate the maximum stress in the cylinder and  
(ii) plot the variation of circumferential and radial stresses along the radius.  
[Ans. (i) 25.866 MN/m<sup>2</sup>]
- If in question 8 above, the long rotating cylinder is having a central hole of diameter 100 mm, then determine :  
(i) maximum circumferential stress,  
(ii) radius at which radial stress is maximum,  
(iii) maximum radial stress,  
(iv) variation of circumferential and radial stresses along the radius of the cylinder. Take all data from question 8. [Ans. (i) 52.27 MN/m<sup>2</sup>, (ii) 0.1 m, (iii) 14.55 MN/m<sup>2</sup>]
- Calculate : (i) maximum and minimum circumferential stress (ii) maximum and minimum radial stress in a thin uniform disc of inner diameter 50 mm and outer diameter 250 mm when rotating at 8000 r.p.m. Take  $\mu = 0.33$  and  $\rho = 8000$  kg/m<sup>3</sup>.  
[Ans. (i) 74.9 MN/m<sup>2</sup>, 17.9 MN/m<sup>2</sup>, (ii) 23.8 MN/m<sup>2</sup>, 0]

# 23

## Bending of Curved Bars

### 23.1. INTRODUCTION

For a straight beam, the bending equation  $\frac{M}{I} = \frac{\sigma}{y} = \frac{E}{R}$  has been derived in chapter 7. This equation can be applied, with sufficient accuracy, to the beams or bars having small initial curvature. However the machine members such as crane hooks, chain links and rings etc. which are having large initial curvature, the simple bending equation cannot be used. This chapter deals with the bending of curved bars, which are having large initial curvature. Actually curved bars means the bars of large initial curvature.

Generally, if the radius of curvature is more than 5 times the depth of the beam, the beam is said to be having small initial curvature. But if radius of curvature is less than 5 times the depth, the beam is said to be having large initial curvature. Hence for large initial curvature, the radius of curvature is small. Also for curved beams, the neutral and centroidal axes do not coincide.

### 23.2. ASSUMPTIONS MADE IN THE DERIVATION OF STRESSES IN A CURVED BAR

Before deriving the expression for the stresses developed in a curved bar when it is subjected to some bending moments, the following assumption are made :

- Transverse sections which are plane before bending remain plane after bending.
- Hook's law is applicable. This means the working stresses are below the limit of proportionality.
- The longitudinal fibres of the bar, parallel to centroidal axis exert no pressure on each other. This means the distance between any longitudinal fibre from centroidal axis is same before and after bending.
- Each layer of the beam is free to expand or contract, independently of the layer, above or below it.

### 23.3. EXPRESSION FOR STRESSES IN A CURVED BAR

Fig. 23.1 shows the two positions of a curved bar, one position [i.e., Fig. 23.1 (a)] is before bending whereas the second position [i.e., Fig. 23.1 (b)] is after bending when some moment  $M$  is applied at the ends of the bar. The centroidal axis is shown by line  $LM$  and  $LM'$  in the two positions respectively.

Consider any fibre  $EF$  at a distance 'y' from the centroidal axis  $LM$ . This fibre takes the position of  $EF'$  when the moment  $M$  is applied. Then the fibre  $EF'$  will be at a distance of 'y'' from the centroidal axis  $LM'$ .

Refer to Fig. 23.1 (a). Here :

- $R$  = radius of curvature of centroidal axis  $LM$ ,
- $\theta$  = angle subtended by centroidal axis  $LM$  at the centre of curvature  $O$ ,
- $y$  = distance of fibre  $EF$  from centroidal axis  $LM$ .

Refer to Fig. 23.1 (b). Here :

- $M$  = uniform bending moment applied to the bar,
- $R'$  = radius of curvature of centroidal axis  $LM'$ ,
- $\theta'$  = angle subtended by centroidal axis  $LM'$  at the centre of curvature  $O'$ ,
- $y'$  = distance of fibre  $E'F'$  from centroidal axis  $LM'$ .

- Let
- $\sigma$  = stress in the strained fibre  $E'F'$  due to bending moment  $M$ , and
  - $e$  = strain in the same fibre  $E'F'$ ,
  - $e_0$  = strain in centroidal layer  $LM$ .

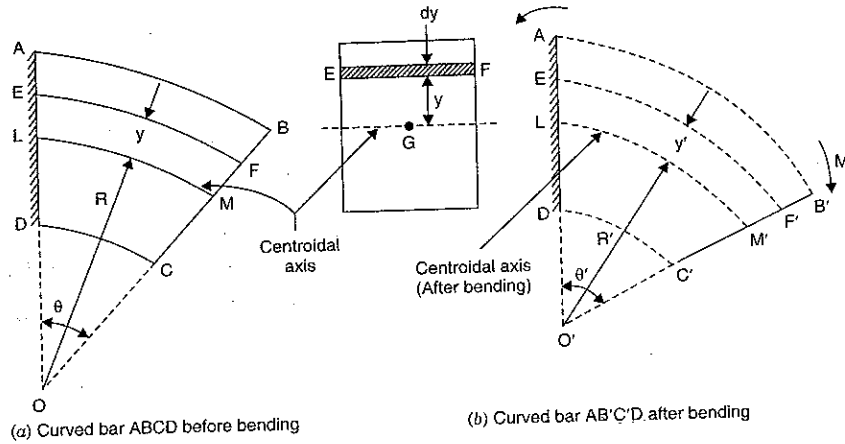

Fig. 23.1

Now, from Figs. 23.1 (a) and 23.1 (b), we have

$$EF = (R + y) \times \theta \quad \text{and} \quad E'F' = (R' + y') \times \theta'$$

Also  $LM = R \times \theta$  and  $LM' = R' \times \theta'$

$$\therefore \text{Strain, } e = \frac{E'F' - EF}{EF} = \frac{(R' + y') \times \theta' - (R + y) \times \theta}{(R + y) \times \theta}$$

$$= \frac{(R' + y') \times \theta'}{(R + y) \times \theta} - \frac{(R + y) \times \theta}{(R + y) \times \theta} = \frac{(R' + y')}{(R + y)} \times \frac{\theta'}{\theta} - 1$$

or  $1 + e = \frac{(R' + y')}{(R + y)} \times \frac{\theta'}{\theta}$  ... (i)

Also, strain,  $e_0 = \frac{LM' - LM}{LM} = \frac{R' \times \theta' - R \times \theta}{R \times \theta} = \frac{R'}{R} \times \frac{\theta'}{\theta} - 1$

or  $1 + e_0 = \frac{R'}{R} \times \frac{\theta'}{\theta}$  ... (ii)

Dividing equation (i) by equation (ii), we get

$$\frac{1 + e}{1 + e_0} = \frac{(R' + y')}{(R + y)} \times \frac{\theta'}{\theta} \bigg/ \left( \frac{R'}{R} \times \frac{\theta'}{\theta} \right)$$

$$= \frac{(R' + y')}{(R + y)} \times \frac{R}{R'} \quad \left( \text{Cancelling } \frac{\theta'}{\theta} \text{ from numerator and denominator} \right)$$

$$= \frac{\left( \frac{R' + y'}{R'} \right)}{\left( \frac{R + y}{R} \right)} = \frac{1 + \frac{y'}{R'}}{1 + \frac{y}{R}}$$

$$\therefore 1 + e = (1 + e_0) \left[ \frac{1 + \frac{y'}{R'}}{1 + \frac{y}{R}} \right] \quad \text{or} \quad e = (1 + e_0) \left[ \frac{1 + \frac{y'}{R'}}{1 + \frac{y}{R}} \right] - 1$$

$$= \frac{(1 + e_0) \left( 1 + \frac{y'}{R'} \right) - \left( 1 + \frac{y}{R} \right)}{\left( 1 + \frac{y}{R} \right)} = \frac{1 + \frac{y'}{R'} + e_0 + e_0 \times \frac{y'}{R'} - 1 - \frac{y}{R}}{\left( 1 + \frac{y}{R} \right)}$$

$$= \frac{\frac{y'}{R'} + e_0 + e_0 \frac{y'}{R'} - \frac{y}{R}}{\left( 1 + \frac{y}{R} \right)} = \frac{\frac{y'}{R'} + e_0 \frac{y'}{R'} + e_0 - \frac{y}{R}}{\left( 1 + \frac{y}{R} \right)}$$

But according to assumption (3),  $y = y'$

$$\therefore e = \frac{\frac{y}{R'} + e_0 \frac{y}{R'} + e_0 - \frac{y}{R}}{\left( 1 + \frac{y}{R} \right)}$$

$$= \frac{\frac{y}{R'} + e_0 \frac{y}{R'} + e_0 - \frac{y}{R} + e_0 \frac{y}{R} - e_0 \frac{y}{R}}{\left( 1 + \frac{y}{R} \right)}$$

[Adding and subtracting the term  $\left( e_0 \frac{y}{R} \right)$ ]

$$= \frac{e_0 + e_0 \frac{y}{R} + \frac{y}{R'} - \frac{y}{R} + e_0 \frac{y}{R'} - e_0 \frac{y}{R}}{\left( 1 + \frac{y}{R} \right)}$$

$$= \frac{e_0 \left( 1 + \frac{y}{R} \right) + y \left( \frac{1}{R'} - \frac{1}{R} \right) + e_0 y \left( \frac{1}{R'} - \frac{1}{R} \right)}{\left( 1 + \frac{y}{R} \right)}$$

$$\begin{aligned}
 &= \frac{e_0 \left(1 + \frac{y}{R}\right) + \left(\frac{1}{R'} - \frac{1}{R}\right)(y + e_0 y)}{\left(1 + \frac{y}{R}\right)} \\
 &= e_0 + \frac{\left(\frac{1}{R'} - \frac{1}{R}\right)(y + e_0 y)}{\left(1 + \frac{y}{R}\right)} = e_0 + \frac{y(1 + e_0) \left(\frac{1}{R'} - \frac{1}{R}\right)}{\left(1 + \frac{y}{R}\right)} \quad \dots(iii)
 \end{aligned}$$

The equation (iii) gives the expression for the strain produced in fibre *EF* under the action of moment *M*.

Now the expression for stress produced in the fibre *EF* can be obtained.

We know that  $\frac{\text{Stress}}{\text{Strain}} = E$

or stress = *E* × strain  
or  $\sigma = E \times e$

$$\sigma = E \times \left[ e_0 + \frac{y(1 + e_0) \left(\frac{1}{R'} - \frac{1}{R}\right)}{\left(1 + \frac{y}{R}\right)} \right] \quad \dots(iv)$$

The above stress is produced due to bending moment *M*. Hence this stress is known as bending stress.

Consider a small strip of area *dA* at a distance *y* from centroidal axis *LM*.

The force on the strip = stress × area of strip  
=  $\sigma \times dA$

Moment of this force about centroidal axis = Force × *y*  
=  $(\sigma \times dA) \times y$

The above expression gives the resisting moment offered by the strip. Total resisting moment is obtained by integrating the above equation.

∴ Total resisting moment =  $\int (\sigma \times dA \times y)$

For equilibrium, the total resisting moment must be equal to applied moment *M*.

$$\begin{aligned}
 \therefore M &= \int \sigma \times dA \times y \quad \text{or} \quad \int \sigma \times y \times dA \\
 &= \int E \times \left[ e_0 + \frac{y(1 + e_0) \left(\frac{1}{R'} - \frac{1}{R}\right)}{\left(1 + \frac{y}{R}\right)} \right] \times y \times dA \\
 &\left[ \because \text{From equation (iv), } \sigma = E \times \left[ e_0 + \frac{y(1 + e_0) \left(\frac{1}{R'} - \frac{1}{R}\right)}{\left(1 + \frac{y}{R}\right)} \right] \right]
 \end{aligned}$$

$$\begin{aligned}
 &= E \int e_0 y dA + E \int \frac{y^2(1 + e_0) \left(\frac{1}{R'} - \frac{1}{R}\right) dA}{\left(1 + \frac{y}{R}\right)} \\
 &= 0 + E(1 + e_0) \left(\frac{1}{R'} - \frac{1}{R}\right) \int \frac{y^2 dA}{\left(1 + \frac{y}{R}\right)} \\
 &\left[ \because \int y dA = 0 \quad \text{and} \quad (ii) \ e_0, R' \text{ and } R \text{ are constants} \right] \\
 &= E(1 + e_0) \left(\frac{1}{R'} - \frac{1}{R}\right) \int \frac{y^2 dA}{\left(1 + \frac{y}{R}\right)}
 \end{aligned}$$

$$\text{Let} \quad \int \frac{y^2 dA}{\left(1 + \frac{y}{R}\right)} = Ah^2 \quad \dots(v)$$

where *h*<sup>2</sup> = a constant for the cross-section of the bar

$$\therefore M = E(1 + e_0) \left(\frac{1}{R'} - \frac{1}{R}\right) \times A \times h^2 \quad \dots(vi)$$

In the above equation *e*<sub>0</sub> and *R'* are unknown.

Let us find the value of *e*<sub>0</sub> and *R'*

We have seen that force on the strip of area *dA* =  $\sigma \times dA$

∴ Total force on the cross-section will be obtained by integrating the above equation.

$$\begin{aligned}
 \therefore \text{Total force, } F &= \int \sigma \times dA = \int E \times \left[ e_0 + \frac{y(1 + e_0) \left(\frac{1}{R'} - \frac{1}{R}\right)}{\left(1 + \frac{y}{R}\right)} \right] dA \\
 &\left[ \text{From equation (iv), } \sigma = E \times \left[ e_0 + \frac{y(1 + e_0) \left(\frac{1}{R'} - \frac{1}{R}\right)}{\left(1 + \frac{y}{R}\right)} \right] \right] \\
 &= E \int e_0 dA + E \int \frac{y(1 + e_0) \left(\frac{1}{R'} - \frac{1}{R}\right)}{\left(1 + \frac{y}{R}\right)} dA \\
 &= E \times e_0 \times A + E(1 + e_0) \left(\frac{1}{R'} - \frac{1}{R}\right) \int \frac{y}{\left(1 + \frac{y}{R}\right)} dA.
 \end{aligned}$$

where *A* = Area of cross-section of the beam.

But for pure bending, there is no force on the section of the beam.

$$\therefore F = 0$$



$$0 = E \times e_0 \times A + E(1 + e_0) \left( \frac{1}{R'} - \frac{1}{R} \right) \int \frac{y}{\left(1 + \frac{y}{R}\right)} dA \quad \dots(vii)$$

Let us now find the value of  $\int \frac{y}{\left(1 + \frac{y}{R}\right)} dA$ .

We know that  $\int \frac{y^2}{\left(1 + \frac{y}{R}\right)} dA = Ah^2$  from equation (v). Hence let us use this value to find

$$\int \frac{y}{\left(1 + \frac{y}{R}\right)} dA$$

$$\int \frac{y}{\left(1 + \frac{y}{R}\right)} dA = \int \frac{\left(y + \frac{y^2}{R} - \frac{y^2}{R}\right)}{\left(1 + \frac{y}{R}\right)} dA$$

(Adding and subtracting  $\frac{y^2}{R}$  to the numerator)

$$= \int \frac{\left[y\left(1 + \frac{y}{R}\right) - \frac{y^2}{R}\right]}{\left(1 + \frac{y}{R}\right)} dA = \int \left[ y - \frac{1}{R} \times \frac{y^2}{\left(1 + \frac{y}{R}\right)} \right] dA$$

$$= \int y dA - \int \frac{1}{R} \times \frac{y^2}{\left(1 + \frac{y}{R}\right)} dA$$

$$= 0 - \frac{1}{R} \int \frac{y^2}{\left(1 + \frac{y}{R}\right)} dA \quad \left[ \because \int y dA = 0 \right]$$

$$= -\frac{1}{R} \times Ah^2 \quad \left[ \because \int \frac{y^2}{\left(1 + \frac{y}{R}\right)} dA = Ah^2 \right]$$

Substituting the value of  $\int \frac{y \cdot dA}{\left(1 + \frac{y}{R}\right)}$  in equation (vii), we get

$$0 = E \times e_0 \times A + E(1 + e_0) \left( \frac{1}{R'} - \frac{1}{R} \right) \times \left( -\frac{1}{R} \times Ah^2 \right)$$

$$\text{or } E(1 + e_0) \left( \frac{1}{R'} - \frac{1}{R} \right) \times \frac{1}{R} \times Ah^2 = E \times e_0 \times A$$

$$\text{or } (1 + e_0) \left( \frac{1}{R'} - \frac{1}{R} \right) \times \frac{h^2}{R} = e_0 \quad \left[ \text{Cancelling } E \times A \text{ to both sides} \right]$$

$$\text{or } (1 + e_0) \left( \frac{1}{R'} - \frac{1}{R} \right) = \frac{e_0 \times R}{h^2} \quad \dots(viii)$$

Substituting the value of  $(1 + e_0) \left( \frac{1}{R'} - \frac{1}{R} \right)$  in equation (vi),

$$\text{We get } M = E \times \frac{e_0 \times R}{h^2} \times A \times h^2 \\ = E \times e_0 \times R \times A$$

$$\text{or } e_0 = \frac{M}{E \times R \times A} \quad \dots(ix)$$

From equation (ix) it is clear that  $e_0$  is constant for a given value of  $M$ ,  $A$  and  $R$ .

Now the expression for stress ( $\sigma$ ) can be obtained by substituting the value of  $(1 + e_0)$

$\left( \frac{1}{R'} - \frac{1}{R} \right)$  from (viii) in equation (iv).

$$\therefore \sigma = E \times \left[ e_0 + \frac{y \times \left( \frac{e_0 \times R}{h^2} \right)}{\left(1 + \frac{y}{R}\right)} \right]$$

$$\left[ \because (1 + e_0) \left( \frac{1}{R'} - \frac{1}{R} \right) = \frac{e_0 \times R}{h^2} \text{ from equation (viii)} \right]$$

$$= E \times e_0 \left[ 1 + \frac{\frac{y \times R}{h^2}}{\left(1 + \frac{y}{R}\right)} \right]$$

$$= E \times \frac{M}{ERA} \left[ 1 + \frac{\left( \frac{y \times R}{h^2} \right)}{\left( \frac{R + y}{R} \right)} \right] \quad \left[ \because \text{From equation (ix) } e_0 = \frac{M}{ERA} \right]$$

$$= \frac{M}{R \times A} \left[ 1 + \frac{R^2}{h^2} \left( \frac{y}{R + y} \right) \right] \quad \dots(23.1)$$

The equation (23.1), gives the expression for tensile stress. The value of 'y' will be -ve, on the downward side of centroidal axis  $LM$ . Hence stress will be opposite to the stress given by equation (23.1).

$$\therefore \sigma(\text{compressive}) = \frac{M}{RA} \left[ 1 + \frac{R^2}{h^2} \left( \frac{-y}{R - y} \right) \right]$$

$$= \frac{M}{RA} \left[ 1 - \frac{R^2}{h^2} \times \left( \frac{y}{R - y} \right) \right] \quad \dots(23.2)$$

The expression for the stress given by equation (23.1) or (23.2) is known as *Winkler-Bach Formula*. The distribution of the stress given by equation (23.1) or (23.2) is hyperbolic (and not linear as in the case of straight beams). The stress distribution is shown in Fig. 23.2.

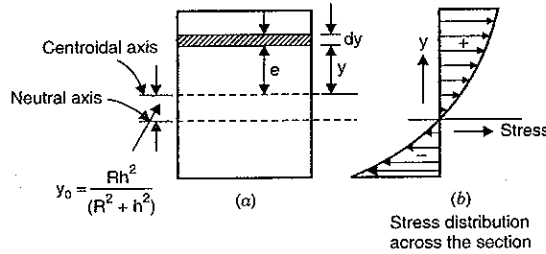

Fig. 23.2

**Position of Neutral Axis.** Let  $y_0$  = distance of neutral axis from centroidal axis.

The stress ( $\sigma$ ) is zero at the neutral axis. Hence position of neutral axis is obtained by substituting  $\sigma = 0$  and  $y = y_0$  in equation (23.1).

$$0 = \frac{M}{R \times A} \left[ 1 + \frac{R^2}{h^2} \left( \frac{y_0}{R + y_0} \right) \right] = 0 \quad \text{or} \quad 1 + \frac{R^2}{h^2} \left( \frac{y_0}{R + y_0} \right) = 0$$

or  $\frac{R^2}{h^2} \left( \frac{y_0}{R + y_0} \right) = -1 \quad \text{or} \quad R^2 y_0 = -h^2 \times R - h^2 \times y_0$

or  $y_0(R^2 + h^2) = -h^2 \times R \quad \text{or} \quad y_0 = -\frac{R \times h^2}{R^2 + h^2} \quad \dots(23.3)$

But 'y' is the distance from centroidal axis. As y is -ve, this means the neutral axis will be at a distance of 'y' below the centroidal axis. Fig. 23.2 (a) shows the position of neutral axis and Fig. 23.2 (b) shows the stress distribution.

**Sign Convention.** The stress across the cross-section will be tensile or compressive according to the following conventions :

1. The bending moment  $M$  will be positive if it increases the curvature of the beam and negative if it decreases the curvature. (Increase of curvature of beam will decrease the radius of curvature).
2. The distance 'y' is positive if it is measured from the centroidal axis towards the convex side of beam, and negative when measured towards the concave side (or towards the centre of curvature).
3. The positive stress means tensile stress, whereas negative stress means compressive stress.

**23.4. DETERMINATION OF FACTOR 'h' FOR VARIOUS SECTIONS**

From equation (v), we have

$$\int \frac{y^2 dA}{\left( 1 + \frac{y}{R} \right)} = Ah^2$$

or 
$$h^2 = \frac{1}{A} \int \frac{y^2}{\left( 1 + \frac{y}{R} \right)} dA = \frac{1}{A} \int \frac{Ry^2}{R+y} dA = \frac{R}{A} \int \frac{y^2}{(R+y)} dA$$

There is some difficulty in integrating the term  $\frac{y^2}{(R+y)}$ , as y is existing in numerator and denominator. Hence  $y^2$  should be eliminated from numerator so that integration can be done easily. By adding and subtracting ' $R^2$ ' to  $y^2$ , integration becomes easy.

$$\begin{aligned} h^2 &= \frac{R}{A} \int \left( \frac{y^2 + R^2 - R^2}{R+y} \right) dA = \frac{R}{A} \int \left( \frac{y^2 - R^2}{(R+y)} + \frac{R^2}{R+y} \right) dA \\ &= \frac{R}{A} \int \left[ \frac{(y-R)(y+R)}{(R+y)} + \frac{R^2}{R+y} \right] dA = \frac{R}{A} \int \left[ (y-R) + \frac{R^2}{R+y} \right] dA \\ &= \frac{R}{A} \left[ \int y dA - \int R dA + \int \left( \frac{R^2}{R+y} \right) dA \right] \\ &= \frac{R}{A} \left[ 0 - R \times A + \int \frac{R^2}{(R+y)} dA \right] \quad \left( \because \int y dA = 0, \int R dA = R \int dA = R \times A \right) \\ &= -R^2 + \frac{R}{A} \int \left( \frac{R^2}{R+y} \right) dA \\ &= \frac{R^3}{A} \int \left( \frac{1}{R+y} \right) dA - R^2 \quad \dots(23.4) \end{aligned}$$

By substituting the values of 'y' and dA for various section in equation (23.4), the value of  $h^2$  is obtained.

**23.4.1. Rectangular Section.** A rectangular section of a curved beam of width 'b' and depth 'd' is shown in Fig. 23.3. The centre of curvature of the curved beam is at O. The radius of curvature from centroidal axis is R. Consider an elementary strip of width 'b' and depth 'dy' at a distance 'y' from the centroidal axis.

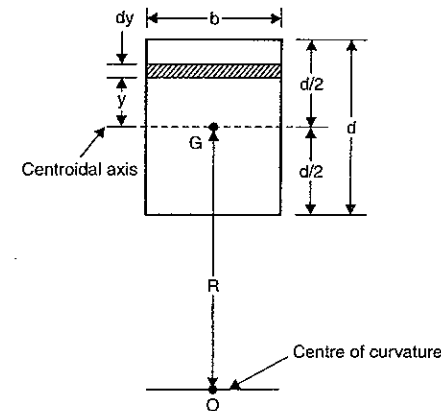

Fig. 23.3

Now area of strip,  $dA = b \times dy$   
 Area of section,  $A = b \times d$   
 From equation (23.4), we have

$$\begin{aligned} h^2 &= \frac{R^3}{A} \int \left( \frac{1}{R+y} \right) dA - R^2 = \frac{R^3}{b \times d} \int_{-d/2}^{+d/2} \frac{1 \times b \times dy}{(R+y)} - R^2 \quad (\because dA = b \times dy) \\ &= \frac{R^3 \times b}{b \times d} \int_{-d/2}^{+d/2} \left( \frac{1}{R+y} \right) dy - R^2 = \frac{R^3}{d} \left[ \log_e (R+y) \right]_{-d/2}^{+d/2} - R^2 \\ &= \frac{R^3}{d} \left[ \log_e \left( R + \frac{d}{2} \right) - \log_e \left( R - \frac{d}{2} \right) \right] - R^2 \\ &= \frac{R^3}{d} \left[ \log_e \left( \frac{R+d/2}{R-d/2} \right) \right] - R^2 = \frac{R^3}{d} \left[ \log_e \left( \frac{2R+d}{2R-d} \right) \right] - R^2 \quad \dots(23.5) \end{aligned}$$

Also  $\log_e \left( \frac{2R+d}{2R-d} \right) = \log_e \left( \frac{R+d/2}{R-d/2} \right) = \frac{d}{R} \left[ 1 + \frac{1}{3} \left( \frac{d}{2R} \right)^2 + \frac{1}{5} \left( \frac{d}{2R} \right)^4 + \dots \right]$

$$\begin{aligned} \therefore h^2 &= \frac{R^3}{d} \left[ \frac{d}{R} \left[ 1 + \frac{1}{3} \left( \frac{d}{2R} \right)^2 + \frac{1}{5} \left( \frac{d}{2R} \right)^4 + \dots \right] \right] - R^2 \\ &= R^2 \left[ 1 + \frac{1}{3} \left( \frac{d}{2R} \right)^2 + \frac{1}{5} \left( \frac{d}{2R} \right)^4 + \dots \right] - R^2 \\ &= R^2 \left[ \frac{1}{3} \left( \frac{d}{2R} \right)^2 + \frac{1}{5} \left( \frac{d}{2R} \right)^4 + \dots \right] \quad \dots[23.5 (A)] \end{aligned}$$

**23.4.2. Triangular Section.** A triangular section of a curved beam of width 'b' and height 'd' is shown in Fig. 23.4. The centre of curvature of the curved beam is at O. The radius of curvature from the centroidal axis is R. Consider a strip of width b\* and depth 'dy' at a distance 'y' from the centroidal axis and also at a distance 'r' from the axis of curvature.

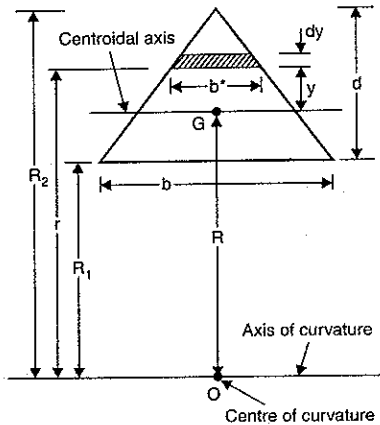

Fig. 23.4

$\therefore r = R + y$   
 and  $dr = 0 + dy = dy$   
 Let  $R_1$  = distance between base of triangle and axis of curvature.  
 $R_2$  = distance between apex of triangle and axis of curvature

Area of triangle,  $A = \frac{b \times d}{2}$   
 Area of strip,  $dA = b^* \times dy$   
 $= \frac{b}{d} (R_2 - r) \times dy = \frac{b}{d} (R_2 - r) \times dr \quad (\because dy = dr)$

where b\* is obtained from

$$\frac{b^*}{b} = \frac{(R_2 - r)}{d}$$

or

$$b^* = \frac{b}{d} (R_2 - r)$$

Now from equation (23.4), we have

$$\begin{aligned} h^2 &= \frac{R^3}{A} \int \frac{dA}{(R+y)} - R^2 \\ &= \frac{R^3}{\left( \frac{b \times d}{2} \right)} \int \frac{\frac{b}{d} (R_2 - r) dr}{r} - R^2 \quad (\because R+y=r) \end{aligned}$$

(limit of integration will be according to dr in which r is the distance from axis of curvature. Hence limits of integration will be from  $R_1$  to  $R_2$ )

$$\begin{aligned} &= \frac{2R^3}{b \times d} \times \frac{b}{d} \int_{R_1}^{R_2} \left( \frac{R_2}{r} - 1 \right) dr - R^2 \\ &= \frac{2R^3}{d^2} \left[ \left( R_2 \log_e r \right)_{R_1}^{R_2} - \left( r \right)_{R_1}^{R_2} \right] - R^2 \\ &= \frac{2R^3}{d^2} [R_2 (\log_e R_2 - \log_e R_1) - (R_2 - R_1)] - R^2 \\ &= \frac{2R^3}{d^2} \left[ R_2 \log_e \left( \frac{R_2}{R_1} \right) - (R_2 - R_1) \right] - R^2 \quad \dots(23.6) \end{aligned}$$

Let us convert  $R_2$  and  $R_1$  in terms of R and d.

Now  $R_2 = R + \frac{2d}{3} = \frac{3R + 2d}{3}$

$$R_1 = R - \frac{d}{3} = \frac{3R - d}{3}$$

and

$$R_2 - R_1 = d$$

Hence the above equation (23.6) becomes as

$$h^2 = \frac{2R^3}{d^2} \left[ \frac{(3R + 2d)}{3} \left\{ \log_e \left( \frac{3R + 2d}{3R - d} \right) \right\} - d \right] - R^2 \quad \dots[23.6 (A)]$$

**23.4.3. Trapezoidal Section.** A trapezoidal section of a curved beam of widths  $b_1$  at the bottom,  $b_2$  at the top and of height  $d$  is shown in Fig. 25.5. The centre of curvature of the curved beam is at  $O$ . The radius of curvature from the centroidal axis is  $R$ . Consider a strip of width  $b$  and depth ' $dy$ ' at a distance of  $y$  from the centroidal axis and at a distance  $r$  from the axis of curvature.

and  $\therefore$   
 $r = R + y$   
 $dr = 0 + dy = dy$   
 Let  $R_1 =$  distance of bottom layer of trapezoidal from axis of curvature  
 $R_2 =$  distance of top layer of trapezoidal from axis of curvature

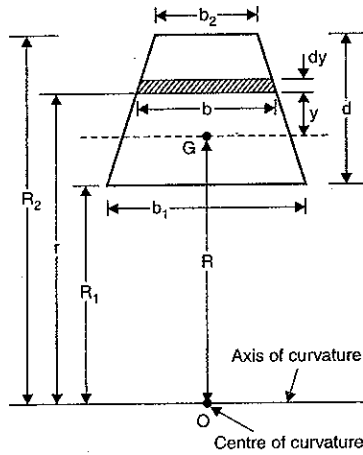

Fig. 23.5

Area of trapezoidal  $= \frac{(b_1 + b_2)}{2} \times d$

Area of strip,  $dA = b \times dy$  where  $b = b_2 + \left(\frac{b_1 - b_2}{d}\right)(R_2 - r)$   
 $= \left[ b_2 + \left(\frac{b_1 - b_2}{d}\right)(R_2 - r) \right] dy = \left[ b_2 + \left(\frac{b_1 - b_2}{d}\right)(R_2 - r) \right] dr$   
 $(\because dy = dr)$

Now from equation (23.4), we have

$$h^2 = \frac{R^3}{A} \int \frac{dA}{(R + y)} - R^2$$

$$= \frac{R^3}{A} \int \frac{\left[ b_2 + \left(\frac{b_1 - b_2}{d}\right)(R_2 - r) \right] dr}{(R + y)} - R^2 \quad \left[ \because dA = b_2 + \left(\frac{b_1 - b_2}{d}\right)(R_2 - r) \right]$$

$$= \frac{R^3}{A} \int \frac{\left[ b_2 + \left(\frac{b_1 - b_2}{d}\right)(R_2 - r) \right] dr}{r} - R^2$$

$$= \frac{R^3}{A} \int \left[ \frac{b_2}{r} + \frac{(b_1 - b_2) \times R_2}{d \times r} - \frac{(b_1 - b_2) \times r}{d \times r} \right] dr - R^2$$

[Here the limits of integration will be according to ' $dr$ ' in which  $r$  is the distance from the axis of curvature. Hence limits will be from  $R_1$  to  $R_2$  (i.e., distances of bottom and top layers of trapezoidal section from axis of curvature.)]

$$= \frac{R^3}{A} \left[ \int_{R_1}^{R_2} \left\{ b_2 + \left(\frac{b_1 - b_2}{d}\right) \times R_2 \right\} \times \frac{1}{r} dr - \int_{R_1}^{R_2} \left(\frac{b_1 - b_2}{d}\right) dr \right] - R^2$$

$$= \frac{R^3}{A} \left[ \left\{ b_2 + \left(\frac{b_1 - b_2}{d}\right) \times R_2 \right\} \left( \log_e r \right)_{R_1}^{R_2} - \frac{(b_1 - b_2)}{d} (r)_{R_1}^{R_2} \right] - R^2$$

$$= \frac{R^3}{A} \left[ \left\{ b_2 + \frac{(b_1 - b_2) \times R_2}{d} \right\} \log_e \left( \frac{R_2}{R_1} \right) - \frac{(b_1 - b_2)}{d} (R_2 - R_1) \right] - R^2$$

$(b_1, b_2, d \text{ and } R_2 \text{ are constants})$

$$= \frac{R^3}{A} \left[ \left\{ b_2 + \frac{(b_1 - b_2) \times R_2}{d} \right\} \log_e \left( \frac{R_2}{R_1} \right) - (b_1 - b_2) \right] - R^2 \quad \dots(23.7)$$

$(\because R_2 - R_1 = d)$

**23.4.4. Circular Section.** A circular section of a curved beam of diameter ' $d$ ' is shown in Fig. 23.6. The centre of curvature of the curved beam is at  $O$ . The radius of curvature from centroidal axis is  $R$ . Consider a strip of width ' $b$ ' and depth ' $dy$ ' at a distance ' $y$ ' from the centroidal axis.

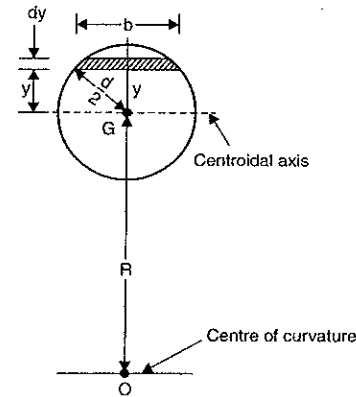

Fig. 23.6

Area of strip,  $dA = b \times dy$  where  $b = \left[ \sqrt{(d/2)^2 - y^2} \right] \times 2$   
 $= \left[ 2 \sqrt{\left(\frac{d}{2}\right)^2 - y^2} \right] \times dy$

Total area of section,  $A = \frac{\pi}{4} d^2$

From equation (23.4), we have

$$h^2 = \frac{R^3}{A} \int_{-d/2}^{+d/2} \frac{dA}{(R+y)} - R^2 = \frac{R^3}{\frac{\pi d^2}{4}} \int_{-d/2}^{+d/2} \frac{2\sqrt{\left(\frac{d}{2}\right)^2 - y^2}}{(R+y)} dy - R^2$$

$$= \frac{8R^3}{\pi d^2} \int_{-d/2}^{+d/2} \frac{\sqrt{\frac{d^2}{4} - y^2}}{(R+y)} dy - R^2$$

The above integral can be expanded by binomial expression and then integrated, we will get

$$h^2 = \frac{d^2}{16} + \frac{1}{128} \frac{d^4}{R^2} + \dots \quad \dots(23.8)$$

**23.4.5. T-section.** A T-section of a curved beam is shown in Fig. 23.7. Consider a strip of width 'b' and thickness 'dy' at a distance y from centroidal axis and at a distance r from axis of curvature. Then  $r = R + y$  and  $dr = 0 + dy = dy$

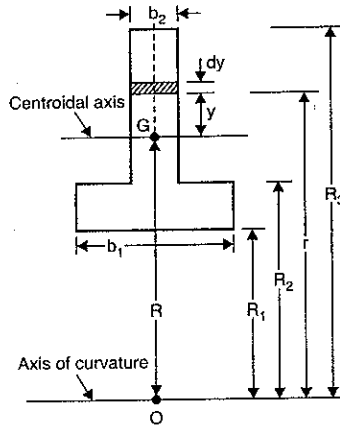

Fig. 23.7

Area of strip =  $b \times dy$

To find  $h^2$ , use equation (23.4),

$$h^2 = \frac{R^3}{A} \int \frac{dA}{(R+y)} - R^2$$

$$= \frac{R^3}{A} \left[ \int_{R_2}^{R_3} \frac{b_2 \times dr}{r} + \int_{R_1}^{R_2} \frac{b_1 \times dr}{r} \right] - R^2$$

$\therefore dA$  between  $R_2$  and  $R_3 = b_2 \times dy = b_2 \times dr$  and between  $R_1$  and  $R_2$ ,  $dA = b_1 \times dy = b_1 \times dr$

$$= \frac{R^3}{A} \left[ b_2 \log_e \left( \frac{R_3}{R_2} \right) + b_1 \log_e \left( \frac{R_2}{R_1} \right) \right] - R^2 \quad \dots(23.9)$$

where  $A =$  total area of T-section =  $b_1 \times (R_2 - R_1) + b_2 \times (R_3 - R_2)$

**23.4.6. I-section.** Fig. 23.8 shows the I-section of a curved beam. Consider a strip of width b and depth dy at a distance y from centroidal axis and at a distance r from the axis of curvature. Then

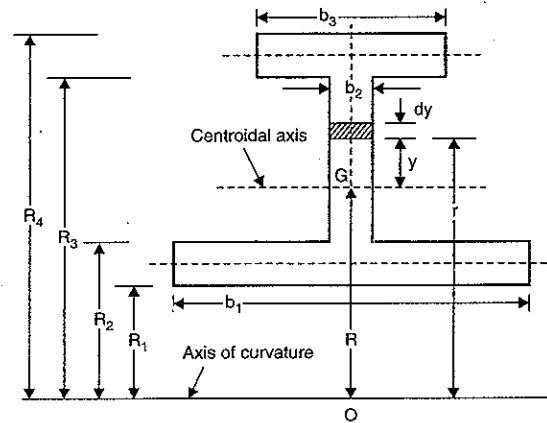

Fig. 23.8

$r = R + y$  where  $R =$  Radius of curvature *i.e.*, distance of centre of curvature from centroidal axis

and

$$dr = dy$$

Area of strip,  $dA = b \times dy = b \times dr$  ( $\because dy = dr$ )

Total area of I-section,  $A = b_1 \times (R_2 - R_1) + b_2 \times (R_3 - R_2) + b_3 \times (R_4 - R_3)$

To find  $h^2$ , use equation (23.4)

$$\therefore h^2 = \frac{R^3}{A} \int \frac{dA}{(R+y)} - R^2 = \frac{R^3}{A} \int \left( \frac{b \times dr}{r} \right) - R^2$$

$$= \frac{R^3}{A} \left[ \int_{R_1}^{R_2} \frac{b_1 \times dr}{r} + \int_{R_2}^{R_3} \frac{b_2 \times dr}{r} + \int_{R_3}^{R_4} \frac{b_3 \times dr}{r} \right] - R^2$$

$$= \frac{R^3}{A} \left[ b_1 \log_e \left( \frac{R_2}{R_1} \right) + b_2 \log_e \left( \frac{R_3}{R_2} \right) + b_3 \log_e \left( \frac{R_4}{R_3} \right) \right] - R^2 \quad \dots(23.10)$$

where  $A = b_1 \times (R_2 - R_1) + b_2 \times (R_3 - R_2) + b_3 \times (R_4 - R_3)$ .

**Problem 23.1.** Determine : (i) location of neutral axis, (ii) maximum and minimum stress, and (iii) ratio of maximum and minimum stress, when a curved beam of rectangular cross-section of width 20 mm and of depth 40 mm is subjected to pure bending of moment + 600 Nm. The beam is curved in a plane parallel to depth. The mean radius of curvature is 50 mm. Also plot the variation of the stresses across the section.

**Sol. Given :**

Curved beam of rectangular section,

Width,  $b = 20$  mm, depth,  $d = 40$  mm,  $\therefore$  Area,  $A = b \times d = 20 \times 40 = 800$  mm<sup>2</sup>

Radius of curvature,  $R = 50$  mm.

Bending moment,  $M = + 600$  Nm =  $600 \times 1000 = 600,000$  Nmm

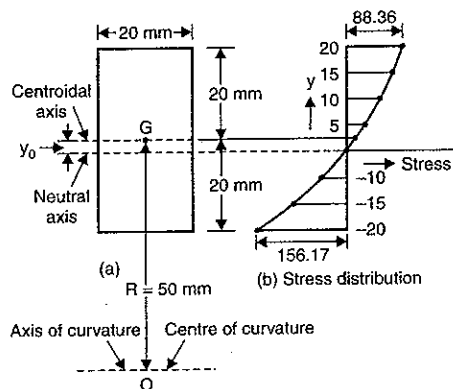

Fig. 23.9

(i) *Location of neutral axis.* Let  $y_0 =$  distance of neutral axis from centroidal axis using equation (23.3), we get

$$y_0 = -\frac{R \times h^2}{R^2 + h^2} \quad \dots(i)$$

Let us find now the value of  $h^2$  for rectangular section

The value of  $h^2$  for rectangular section is given by equation (23.5) as

$$\begin{aligned} h^2 &= \frac{R^3}{d} \left[ \log_e \left( \frac{2R+d}{2R-d} \right) \right] - R^2 = \frac{50^3}{40} \left[ \log_e \left( \frac{2 \times 50 + 40}{2 \times 50 - 40} \right) \right] - 50^2 \\ &= 3125 \left[ \log_e \left( \frac{140}{60} \right) \right] - 2500 = 3125 [ \log_e (2.333) ] - 2500 \\ &= 3125 \times 0.847 - 2500 = 2646.8 - 2500 = 146.8 \end{aligned}$$

$$\therefore y_0 = -\frac{50 \times (146.8)}{50^2 + (146.8)} = -2.773 \text{ mm. Ans.}$$

-ve sign means the neutral axis will be below central axis at a distance of 2.773 mm.

The value of  $h^2$  can also be obtained from equation [23.5 (A)] as

$$\begin{aligned} h^2 &= R^2 \left[ \frac{1}{3} \left( \frac{d}{2R} \right)^2 + \frac{1}{5} \left( \frac{d}{2R} \right)^4 + \dots \right] \\ &= 50^2 \left[ \frac{1}{3} \times \left( \frac{40}{2 \times 50} \right)^2 + \frac{1}{5} \left( \frac{40}{2 \times 50} \right)^4 + \dots \right] \\ &= 2500 \left[ \frac{1}{3} \times 0.16 + \frac{1}{5} \times 0.0064 + \dots \right] \end{aligned}$$

$$= 2500 [0.0533 + 0.00512] = 2500 \times .05842 = 146.05$$

$$\therefore y_0 = \frac{-50 \times 146.05}{50^2 + 146.05} = \frac{-50 \times 146.05}{2646.05} = -2.759 = -2.76 \text{ mm. Ans.}$$

(ii) *Maximum and minimum stresses.* The stress at any layer in the cross-section at a distance 'y' from centroidal axis is given by equation (23.1) as

$$\sigma = \frac{M}{R \times A} \left[ 1 + \frac{R^2}{h^2} \left( \frac{y}{R+y} \right) \right]$$

For a given value of  $M, R$  and  $A$ , the stress will be maximum when  $y$  is -ve and maximum. Hence maximum stress will occur at the extreme bottom layer where  $y = -20$  mm.

$$\begin{aligned} \therefore \sigma_{\max} &= \frac{600,000}{50 \times 800} \left[ 1 + \frac{50^2}{146.05} \left( \frac{-20}{50-20} \right) \right] \\ &= 15 \left[ 1 - \frac{2500 \times 20}{146.05 \times 30} \right] = 15 [1 - 11.41] = 15 \times (-10.41) \\ &= -156.17 \text{ N/mm}^2. \text{ (compressive) Ans.} \end{aligned}$$

Minimum stress occurs at the extreme top layer where  $y = 20$  mm

$$\begin{aligned} \therefore \sigma_{\min} &= \frac{600,000}{50 \times 800} \left[ 1 + \frac{50^2}{146.05} \left( \frac{20}{50+20} \right) \right] = 15 \left[ 1 + \frac{2500 \times 20}{146.05 \times 70} \right] = 15 [1 + 4.89] \\ &= 15 \times 5.89 = 88.36 \text{ N/mm}^2. \text{ (tensile) Ans.} \end{aligned}$$

(iii) *Ratio of  $\sigma_{\max}$  and  $\sigma_{\min}$*

$$\therefore \frac{\sigma_{\max}}{\sigma_{\min}} = \frac{156.17}{88.36} = 1.767. \text{ Ans.} \quad \text{(Here take magnitude only)}$$

(iv) *Plotting the stresses across the cross-section.* Stress at any distance 'y' from neutral axis is given by equation (23.1) as

$$\begin{aligned} \sigma &= \frac{M}{R \times A} \left[ 1 + \frac{R^2}{h^2} \left( \frac{y}{R+y} \right) \right] = \frac{600,000}{50 \times 800} \left[ 1 + \frac{50^2}{146.05} \left( \frac{y}{50+y} \right) \right] \\ &= 15 \left[ 1 + 17.11 \left( \frac{y}{50+y} \right) \right] \quad \dots(ii) \end{aligned}$$

By substituting the various values of  $y$  in equation (ii), different values of stress are obtained.

$$\text{At } y = 0, \quad \sigma = 15 \left[ 1 + \frac{17.11 \times 0}{50+0} \right] = 15 \times 1 = 15 \text{ N/mm}^2$$

$$\text{At } y = 5 \text{ mm, } \sigma = 15 \left[ 1 + 17.11 \times \left( \frac{5}{50+5} \right) \right] = 38.33 \text{ N/mm}^2$$

$$\text{At } y = 10 \text{ mm, } \sigma = 15 \left[ 1 + 17.11 \times \left( \frac{10}{50+10} \right) \right] = 57.77 \text{ N/mm}^2$$

$$\text{At } y = 15 \text{ mm, } \sigma = 15 \left[ 1 + 17.11 \times \left( \frac{15}{50+15} \right) \right] = 74.22 \text{ N/mm}^2$$

$$\text{At } y = 20 \text{ mm, } \sigma = 15 \left[ 1 + 17.11 \times \left( \frac{20}{50 + 20} \right) \right] = 88.36 \text{ N/mm}^2$$

At  $y = y_0 = -2.76 \text{ mm}$ ,  $\sigma = 0$  at neutral axis

$$\text{At } y = -5 \text{ mm, } \sigma = 15 \left[ 1 + 17.11 \times \left( \frac{-5}{50 - 5} \right) \right] = -13.5 \text{ N/mm}^2$$

$$\text{At } y = -10 \text{ mm, } \sigma = 15 \left[ 1 + 17.11 \times \left( \frac{-10}{50 - 10} \right) \right] = -49.16 \text{ N/mm}^2$$

$$\text{At } y = -15 \text{ mm, } \sigma = 15 \left[ 1 + 17.11 \times \left( \frac{-15}{50 - 15} \right) \right] = -95 \text{ N/mm}^2$$

$$\text{At } y = -20 \text{ mm, } \sigma = -156.17 \text{ N/mm}^2$$

The variation of the stress across the section is plotted in Fig. 23.3 (b).

**Problem 23.2.** Determine : (i) Location of neutral axis,  
(ii) Maximum and minimum stresses.

When a curved beam of trapezoidal section of bottom width 30 mm, top width 20 mm and height 40 mm is subjected to pure bending moment of + 600 Nm. The bottom width is towards the centre of curvature. The radius of curvature is 50 mm and beam is curved in a plane parallel to depth. Also plot the variation of stresses across the section.

**Sol.** Given :

$$b_1 = 30 \text{ mm, } b_2 = 20 \text{ mm, } d = 40 \text{ mm, } M = + 600 \text{ Nm} = 600 \times 1000 \text{ Nmm}$$

$$R = 50 \text{ mm.}$$

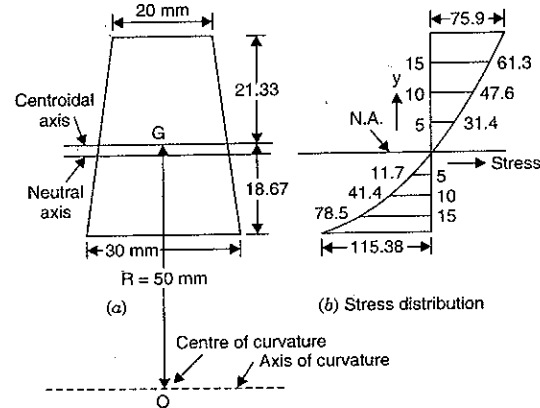

Fig. 23.10

Let us first find the location of centroidal axis. The distance ' $d_1$ ' of centroidal axis from the side  $b_1$  is given by,

$$d_1 = \left( \frac{b_1 + 2b_2}{b_1 + b_2} \right) \times \frac{d}{3} = \left( \frac{30 + 2 \times 20}{30 + 20} \right) \times \frac{40}{3} = \frac{70}{50} \times \frac{40}{3} = 18.67 \text{ mm}$$

and

$$d_2 = 40 - 18.67 = 21.33 \text{ mm}$$

Let us now find  $R_1$ ,  $R_2$  and area  $A$ .

$$R_1 = R - d_1 = 50 - 18.67 = 31.33 \text{ mm}$$

$$R_2 = R + d_2 = 50 + 21.33 = 71.33 \text{ mm}$$

$A$  = Area of trapezoidal section

$$= \left( \frac{b_1 + b_2}{2} \right) \times d = \left( \frac{30 + 20}{2} \right) \times 40 = 1000 \text{ mm}^2$$

Let us now find  $h^2$  for trapezoidal section. Using equation (23.7), we get

$$h^2 = \frac{R^3}{A} \left[ \left\{ b_2 + \left( \frac{b_1 - b_2}{d} \right) \times R_2 \right\} \log_e \left( \frac{R_2}{R_1} \right) - (b_1 - b_2) \right] - R^2$$

$$= \frac{50^3}{1000} \left[ \left\{ 20 + \frac{30 - 20}{40} \times 71.33 \right\} \log_e \left( \frac{71.33}{31.33} \right) - (30 - 20) \right] - 50^2$$

$$= 125 [ \{ 20 + 17.83 \} \times 0.8227 - 10 ] - 2500 = 140.34$$

(i) Location of neutral axis. Let  $y_0$  = distance of neutral axis from centroidal axis. The location of neutral axis is given by equation (23.3) as

$$y_0 = - \frac{R \times h^2}{R^2 + h^2} = - \frac{50 \times 140.34}{50^2 + 140.34}$$

$$= - \frac{50 \times 140.34}{2640.34} = -2.65 \text{ mm. Ans.}$$

-ve sign means the neutral axis will be below the centroidal axis at a distance of 2.65 mm.

(ii) Maximum and minimum stresses. The stress at any layer at a distance ' $y$ ' from centroidal axis is given by equation (23.1) as

$$\sigma = \frac{M}{R \times A} \left[ 1 + \frac{R^2}{h^2} \left( \frac{y}{R + y} \right) \right]$$

The stress will be maximum at the extreme bottom layer where

$$y = -18.67 \text{ mm}$$

$$\therefore \sigma_{\max} = \frac{600,000}{50 \times 1000} \left[ 1 + \frac{50^2}{140.34} \left( \frac{-18.67}{50 - 18.67} \right) \right]$$

$$= 12 [ 1 + (-10.61) ] = 12 \times (-9.61) = -115.38 \text{ N/mm}^2. \text{ Ans.}$$

$$= 115.38 \text{ N/mm}^2 \text{ (compressive)}$$

Minimum stress occurs at the extreme top layer where  $y = 21.33 \text{ mm}$

$$\therefore \sigma_{\min} = \frac{600,000}{50 \times 1000} \left[ 1 + \frac{50^2}{140.34} \times \left( \frac{21.33}{50 + 21.33} \right) \right]$$

$$= 12 ( 1 + 5.326 ) = 75.9 \text{ N/mm}^2. \text{ (tensile). Ans.}$$

(iii) Plotting the stresses across the section

$$\sigma = \frac{M}{R \times A} \left[ 1 + \frac{R^2}{h^2} \left( \frac{y}{R + y} \right) \right] = \frac{600000}{50 \times 1000} \left[ 1 + \frac{50^2}{140.34} \left( \frac{y}{50 + y} \right) \right]$$

$$= 12 \left[ 1 + 17.8 \times \left( \frac{y}{50 + y} \right) \right]$$

At  $y = 21.33$  mm,  $\sigma = 75.9$  N/mm<sup>2</sup> (Already calculated)

At  $y = 15$  mm,  $\sigma = 12 \left[ 1 + \frac{17.8 \times 15}{(50 + 15)} \right] = 61.3$  N/mm<sup>2</sup>

At  $y = 10$  mm,  $\sigma = 12 \left[ 1 + \frac{17.8 \times 10}{(50 + 10)} \right] = 47.6$  N/mm<sup>2</sup>

At  $y = 5$  mm,  $\sigma = 12 \left[ 1 + \frac{17.8 \times 5}{(50 + 5)} \right] = 31.4$  N/mm<sup>2</sup>

At  $y = 0$ ,  $\sigma = 12 (1 + 0) = 12$  N/mm<sup>2</sup>

At  $y = -5$  mm,  $\sigma = 12 \left[ 1 + \frac{17.8 \times (-5)}{(50 - 5)} \right] = -11.7$  N/mm<sup>2</sup>

At  $y = -10$  mm,  $\sigma = 12 \left[ 1 + \frac{17.8 \times (-10)}{(50 - 10)} \right] = -41.4$  N/mm<sup>2</sup>

At  $y = -15$  mm,  $\sigma = 12 \left[ 1 + \frac{17.8 \times (-15)}{(50 - 15)} \right] = -78.5$  N/mm<sup>2</sup>

At  $y = -18.67$  mm,  $\sigma = -115.38$  N/mm<sup>2</sup> (Already calculated)

Fig. 23.10 (b) shows the stress distribution across the section.

**Problem 23.3.** Determine : (i) position of neutral axis, and (ii) maximum and minimum stresses when a curved beam of circular section of diameter 100 mm is subjected to pure bending moment of + 11.5 kNm. The radius of curvature is 100 mm.

**Sol.** Given :

$d = 100$  mm, B.M.,  $M = + 11.5$  kNm =  $11.5 \times 10^3$  Nm  
 =  $(11.5 \times 10^3) \times 10^3$  Nmm =  $11.5 \times 10^6$  Nmm, radius of curvature,  $R = 100$  mm.

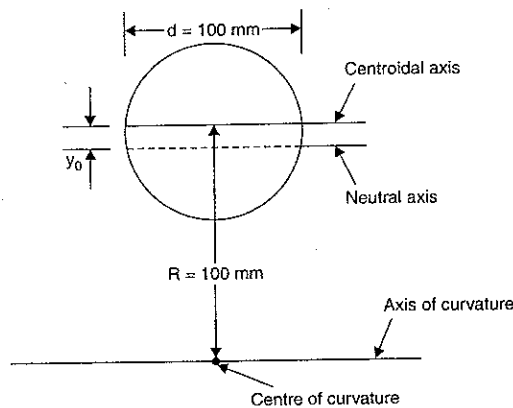

Fig. 23.11

(i) Position of neutral axis. Let  $y_0$  = distance of neutral axis from centroidal axis the position of neutral axis is given by equation (23.3) as

$$y_0 = - \frac{R \times h^2}{R^2 + h^2} \quad \dots(i)$$

The value of  $h^2$  for circular section is given by equation (23.8) as,

$$h^2 = \frac{d^2}{16} + \frac{1}{128} \times \frac{d^4}{R^2} + \dots = \frac{100^2}{16} + \frac{1}{128} \times \frac{100^4}{100^2}$$

(Here  $R = 100$  mm and  $d$  also = 100 mm)

$$= \frac{10000}{16} + \frac{10000}{128} = \frac{90000}{128} = 703.125$$

Substituting this value of  $h^2$  in equation (i), we get

$$y_0 = - \frac{100 \times 703.125}{100^2 + 703.125} = -6.57 \text{ mm. Ans.}$$

-ve sign means the neutral axis will be below the centroidal axis.

(ii) Maximum and minimum stresses. The stress at any layer at a distance of  $y$  from centroidal axis is given by equation (23.1) as

$$\sigma = \frac{M}{R \times A} \left[ 1 + \frac{R^2}{h^2} \left( \frac{y}{R + y} \right) \right]$$

where  $A$  = Area of cross-section =  $\frac{\pi}{4} \times d^2 = \frac{\pi}{4} \times 100^2 = 2500 \pi$  mm<sup>2</sup>

$$M = 11.5 \times 10^6 \text{ Nmm}$$

The stress will be maximum at the extreme bottom layer where  $y = -50$  mm

$$\therefore \sigma_{\max} = \frac{11.5 \times 10^6}{100 \times 2500 \pi} \left[ 1 + \frac{100^2}{703.125} \left( \frac{-50}{100 - 50} \right) \right]$$

$$= 14.636 [1 - 14.222] = -193.52 \text{ N/mm}^2$$

$$= 193.52 \text{ N/mm}^2 \text{ (compressive). Ans.}$$

The stress will be minimum at the extreme top layer where  $y = +50$  mm.

$$\therefore \sigma_{\min} = \frac{11.5 \times 10^6}{100 \times 2500 \pi} \left[ 1 + \frac{100^2}{703.125} \left( \frac{50}{100 + 50} \right) \right]$$

$$= 14.636 [1 + 4.74] = 84.02 \text{ N/mm}^2 \text{ (tensile) Ans.}$$

### 23.5. RESULTANT STRESS IN A CURVED BAR SUBJECTED TO DIRECT STRESSES AND BENDING STRESSES

In the previous article, we have considered the bending of the curved bars which are subjected to pure bending. Hence the stress across the cross-section is only bending stress which is due to B.M. only. But in case of curved members like hooks, rings and chains which carry vertical loads, there is bending stress as well as direct stress.

Hence the stress at any point in the cross-section of these members will be equal to algebraic sum of direct stress ( $\sigma_0$ ) due to vertical load ( $P$ ) and bending stress ( $\sigma_b$ ). It is assumed that vertical load  $P$  acts through the centroid of the section and the stress due to this load is

equal to  $\frac{P}{A}$  at each point on the cross-section. Hence the resultant stress at any point will be

$$\sigma_R = \sigma_0 + \sigma_b \text{ where } \sigma_b \text{ from equation (23.1)}$$

$$= \sigma = \frac{M}{A \times R} \left[ 1 + \frac{R^2}{h^2} \left( \frac{y}{R + y} \right) \right] \quad \dots(23.11)$$



$$\sigma_R = \frac{P}{A} + \frac{M}{A \times R} \left[ 1 + \frac{R^2}{h^2} \left( \frac{y}{R+y} \right) \right] \quad \dots[23.11 (A)]$$

If  $P$  is tensile load, then,  $\frac{P}{A}$  will be +ve and if  $P$  is compressive load, then  $\frac{P}{A}$  will be -ve.

**23.6. RESULTANT STRESS IN A HOOK**

Fig. 23.12 shows a hook, which supports a vertical load  $P$ . The centre of curvature of the hook is at  $O$ . Consider a horizontal section  $AC$  passing through the centre of curvature of the hook. This section carries the maximum stress. This horizontal section may be trapezoidal or any other shape. The centroidal axis of the section is represented by  $BB$ .

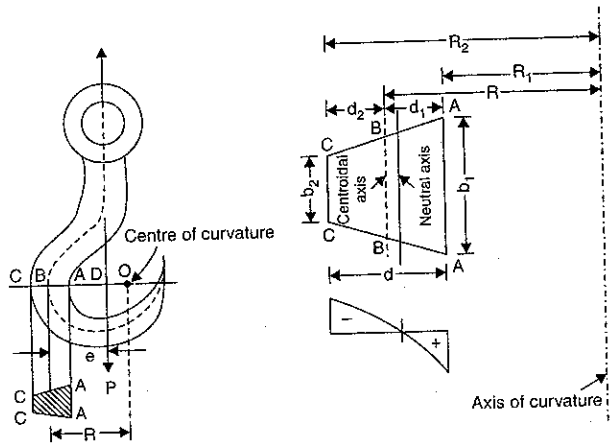

Fig. 23.12

Let  $P$  = Load supported by hook.

$e$  = Eccentricity of the load i.e., the distance between the load line and centroidal axis.

$R$  = Radius of curvature of the curved hook i.e., distance between axis of curvature and centroidal axis.

The other dimensions such as  $b_1, b_2, d, R_1$  and  $R_2$  are as usual. The bending moment caused by load  $P$  is given by,

$$M = P \times e$$

This bending moment is -ve as it decreases the curvature of the hook. Hence  $M = -P \times e$  the resultant stress at any point across the section is given by equation (23.11) as

$$\sigma_R = \sigma_0 + \sigma_b$$

$$= \frac{P}{A} + \frac{M}{A \times R} \left[ 1 + \frac{R^2}{h^2} \left( \frac{y}{R+y} \right) \right]$$

Here load  $P$  is tensile, hence direct stress ( $\sigma_0 = \frac{P}{A}$ ) will be tensile stress and hence it will be +ve. Bending moment  $M = -P \times e$ .

Hence above equation becomes as

$$\sigma_R = \frac{P}{A} - \frac{P \times e}{A \times R} \left[ 1 + \frac{R^2}{h^2} \left( \frac{y}{R+y} \right) \right]$$

The bending moment here produces tensile stress at  $AA$  and compressive stress at  $CC$ . The vertical load  $P$  produces tensile stress over the whole section.

**Problem 23.4.** A hook carries a load of 7.5 kN and the load line is at a distance of 20 mm from the inner edge of the section which is trapezoidal. The load line also passes through the centre of curvature of the hook. The dimensions of the central horizontal trapezoidal section are : inner width = 30 mm ; outer width = 15 mm ; depth = 30 mm. Calculate the maximum and minimum stresses. Also plot the variation of stress across the section.

**Sol.** Given :

Load,  $P = 7.5 \text{ kN} = 7.5 \times 1000 \text{ N}$ .

Distance of load line from inner edge of the section = 20 mm. Centre of curvature lies on load line. This means the radius of curvature and eccentricity will be equal.

$$R = e$$

Dimensions of trapezoidal section.

Inner width,  $b_1 = 30 \text{ mm}$ , outer width,  $b_2 = 15 \text{ mm}$  and depth,  $d = 30 \text{ mm}$ .

Refer to Fig. 23.13.

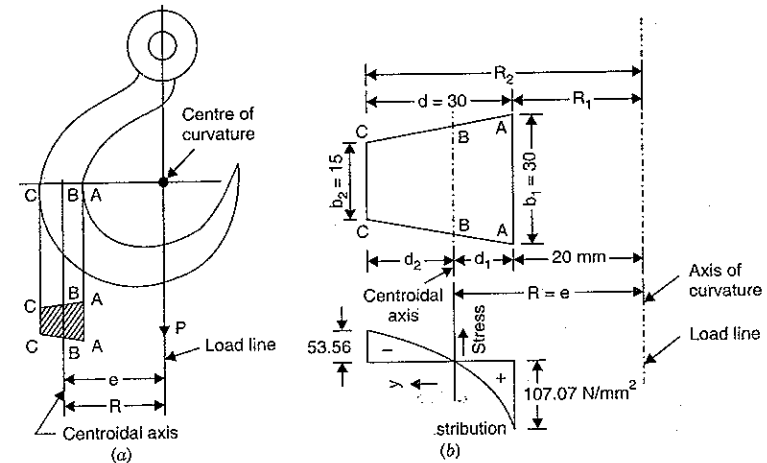

Fig. 23.13

Let us first find the location of centroidal axis.

The distance  $d_1$  of the centroidal axis from the side  $b_1$  is given by

$$d_1 = \left( \frac{b_1 + 2b_2}{b_1 + b_2} \right) \times \frac{d}{3} = \left( \frac{30 + 2 \times 15}{30 + 15} \right) \times \frac{30}{3} = \frac{60}{45} \times 10 = 13.33 \text{ mm}$$

$$d_2 = d - d_1 = 30 - 13.33 = 16.67 \text{ mm}$$

From Fig. 23.13, it is clear that

$$R_1 = 20 \text{ mm}, R = 20 + d_1 = 20 + 13.33 = 33.33 \text{ mm},$$

$$R_2 = 20 + d = 20 + 30 = 50 \text{ mm}$$

$$e = R = 33.33 \text{ mm}$$

Area of section,  $A = \left(\frac{b_1 + b_2}{2}\right) \times d = \frac{30 + 15}{2} \times 30 = 675 \text{ mm}^2$

Bending moment,  $M = -P \times e$  (-ve sign is used as the applied load decreases the curvature of the hook)

$$= -(7.5 \times 1000) \times 33.33 = -249975 \text{ Nmm}$$

Let us now find the value of  $h^2$  for trapezoidal section. It is given by equation (23.7) as

$$h^2 = \frac{R^3}{A} \left[ \left\{ b_2 + \frac{(b_1 - b_2) \times R_2}{d} \right\} \log_e \left( \frac{R_2}{R_1} \right) - (b_1 - b_2) \right] - R^2$$

$$= \frac{33.33^3}{675} \left[ \left\{ 15 + \frac{30 - 15}{30} \times 50 \right\} \log_e \left( \frac{50}{20} \right) - (30 - 15) \right] - 33.33^2$$

$$= 54.85 [40 \log_e 2.5 - 15] - 1110.8$$

$$= 1187.6 - 1110.8 = 76.8 \text{ mm}^2.$$

(i) *Max. and min. stresses.* The bending stress at any point is given by equation (23.1) as

$$\sigma_b = \sigma = \frac{M}{A \times R} \left[ 1 + \frac{R^2}{h^2} \left( \frac{y}{R + y} \right) \right] = \frac{-249975}{675 \times 33.33} \left[ 1 + \frac{33.33^2}{76.8} \left( \frac{y}{R + y} \right) \right]$$

$$= -11.11 \left[ 1 + 14.46 \times \left( \frac{y}{R + y} \right) \right]$$

Stress at the section C-C, where  $y = d_2 = 16.67 \text{ mm}$ ,

$$\sigma_{cc} = -11.11 \left[ 1 + 14.46 \times \frac{16.67}{(33.33 + 16.67)} \right] = -64.67 \text{ N/mm}^2 \text{ (compressive)}$$

Stress at the section A-A, where  $y = -d_1 = -13.33$ ,

$$\sigma_{AA} = -11.11 \left[ 1 + 14.46 \times \frac{(-13.33)}{(33.33 - 13.33)} \right] = -11.11 \left[ 1 - \frac{14.46 \times 13.33}{20} \right]$$

$$= +95.96 \text{ N/mm}^2 \text{ (tensile)}$$

We know that direct stress ( $\sigma_0$ ) is given by

$$\sigma_0 = \frac{P}{A} = \frac{7.5 \times 1000}{675} = 11.11 \text{ N/mm}^2 \text{ (tensile)}$$

The direct stress is uniform at all points in the cross-section

∴ Resultant stress at AA =  $\sigma_0 + \sigma_{AA}$

$$= 11.11 + 95.96 = 107.07 \text{ N/mm}^2 \text{ (tensile). Ans.}$$

Resultant stress at CC =  $\sigma_0 + \sigma_{cc}$

$$= 11.11 - 64.67$$

$$= -53.56 \text{ N/mm}^2 \text{ (compressive). Ans.}$$

(ii) *Plotting of stresses.* The resultant stress at any distance  $y$  from the centroidal axis is given by,

$$\sigma_r = \sigma_0 + \sigma_b (= \sigma)$$

$$= 11.11 + \frac{M}{A \times R} \left[ 1 + \frac{R^2}{h^2} \times \left( \frac{y}{R + y} \right) \right]$$

$$= 11.11 + \frac{-249975}{675 \times 33.33} \left[ 1 + \frac{33.33^2}{76.8} \times \left( \frac{y}{33.33 + y} \right) \right]$$

$$= 11.11 - 11.11 \left[ 1 + 14.46 \times \left( \frac{y}{33.33 + y} \right) \right]$$

At  $y = 0$ ,  $\sigma_r = 11.11 - 11.11 = 0$

At  $y = 5 \text{ mm}$ ,  $\sigma_r = 11.11 - 11.11 \left[ 1 + \frac{14.46 \times 5}{33.33 + 5} \right] = -20.95 \text{ N/mm}^2$

At  $y = 10 \text{ mm}$ ,  $\sigma_r = 11.11 - 11.11 \left[ 1 + \frac{14.46 \times 10}{33.33 + 10} \right] = -37.07 \text{ N/mm}^2$

At  $y = 15 \text{ mm}$ ,  $\sigma_r = 11.11 - 11.11 \left[ 1 + \frac{14.46 \times 15}{33.33 + 15} \right] = -49.86 \text{ N/mm}^2$

At  $y = 16.67 \text{ mm} = d_2$ ,  $\sigma_r = -53.56 \text{ N/mm}^2$  (Already calculated)

At  $y = -5 \text{ mm}$ ,  $\sigma_r = 11.11 - 11.11 \left[ 1 + \frac{14.46 \times (-5)}{33.33 - 5} \right] = 28.35 \text{ N/mm}^2$

At  $y = -10 \text{ mm}$ ,  $\sigma_r = 11.11 - 11.11 \left[ 1 + \frac{14.46 \times (-10)}{33.33 - 10} \right] = 68.86 \text{ N/mm}^2$

At  $y = -13.33 \text{ mm}$ ,  $\sigma_r = 107.07 \text{ N/mm}^2$

The variation of stress across the cross-section is shown in Fig. 23.13 (b).

**Problem 23.5.** A central horizontal section of a hook is a trapezoidal section shown in Fig. 23.14. Calculate the maximum compressive and tensile stresses in the section of the hook when it carries a load of 37.5 kN, the load line passes through the centre of curvature.

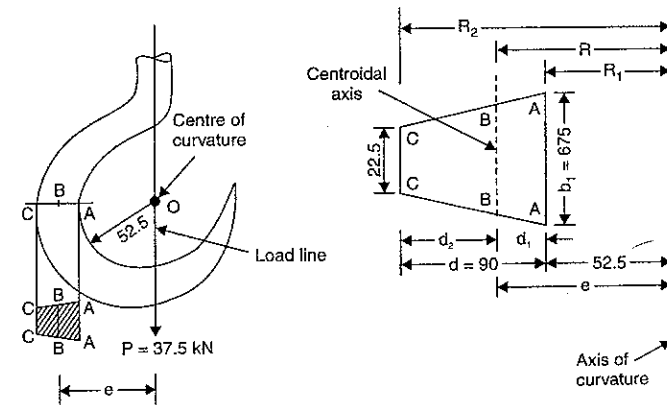

Fig. 23.14

Sol. Given :  $P = 37.5 \text{ kN} = 37.5 \times 1000 \text{ N}$

Load line passes through centre of curvature

$\therefore$  Eccentricity,  $e = R$  (radius of curvature)

where  $e =$  distance between load line and centroidal axis

and  $R =$  distance between centre of curvature and centroidal axis.

Dimensions of trapezoidal section are :

$$b_1 = 67.5 \text{ mm}, b_2 = 22.5 \text{ mm}, d = 90 \text{ mm}$$

Refer to Fig. 23.14.

Let us first find the location of centroidal axis.

The distance  $d_1$  of the centroidal axis from the side  $b_1$  is given by

$$d_1 = \left( \frac{b_1 + 2b_2}{b_1 + b_2} \right) \times \frac{d}{3} = \left( \frac{67.5 + 2 \times 22.5}{67.5 + 22.5} \right) \times \frac{90}{3} = \frac{112.5}{90} \times \frac{90}{3} = 37.5 \text{ mm}$$

$\therefore d_2 = d - d_1 = 90 - 37.5 = 52.5 \text{ mm}$

From Fig. 23.14, it is clear that

$$R_1 = 52.5 \text{ mm. Then } R = R_1 + d_1 = 52.5 + 37.5 = 90 \text{ mm}$$

$$R_2 = 52.5 + d = 52.5 + 90 = 142.5 \text{ mm}$$

$$e = R = 90 \text{ mm}$$

Area of the section,

$$A = \left( \frac{b_1 + b_2}{2} \right) \times d = \frac{67.5 + 22.5}{2} \times 90 = 4050 \text{ mm}^2$$

Bending moment,  $M = -P \times e$  (-ve sign is used as the applied load decreases the curvature of the hook)

$$= -(37.5 \times 1000) \times 90 \text{ Nmm} = -3375000 \text{ Nmm}$$

Let us now find the value of  $h^2$  for trapezoidal axis. It is given by equation (23.7) as

$$\begin{aligned} h^2 &= \frac{R^3}{A} \left[ \left\{ b_2 + \frac{b_1 - b_2}{d} \times R_2 \right\} \log_e \left( \frac{R_2}{R_1} \right) - (b_1 - b_2) \right] - R^2 \\ &= \frac{90^3}{4050} \left[ \left\{ 22.5 + \frac{67.5 - 22.5}{90} \times 142.5 \right\} \log_e \left( \frac{142.5}{52.5} \right) - (67.5 - 22.5) \right] - 90^2 \\ &= 180 [(93.75 \times \log_e 2.714^3) - 45] - 8100 \\ &= 8750.26 - 8100 = 650.26 \text{ mm}^2 \end{aligned}$$

$$\text{Direct stress, } \sigma_0 = \frac{P}{A} = \frac{37.5 \times 1000}{4050} = 9.26 \text{ N/mm}^2$$

Bending stress at any layer at a distance  $y$  from centroidal axis is given by,

$$\begin{aligned} \sigma &= \frac{M}{A \times R} \left[ 1 + \frac{R^2}{h^2} \left( \frac{y}{R+y} \right) \right] \\ &= -\frac{3375000}{4050 \times 90} \left[ 1 + \frac{90^2}{650.26} \left( \frac{y}{90+y} \right) \right] \quad [\because M = -3375000 \text{ N mm}] \\ &= -9.26 \left[ 1 + \frac{12.456y}{90+y} \right] \quad \dots(i) \end{aligned}$$

Bending stress at section C-C where  $y = d_2 = 52.5 \text{ mm}$  becomes as

$$\sigma_{cc} = -9.26 \left[ 1 + \frac{12.456 \times 52.5}{90 + 52.5} \right] = -51.75 \text{ N/mm}^2$$

$\therefore$  Resultant stress at section C - C becomes

$$\begin{aligned} (\sigma_r)_{cc} &= \sigma_0 + \sigma_{cc} \\ &= 9.26 - 51.75 = -42.49 \text{ N/mm}^2 \text{ (Compressive). Ans.} \end{aligned}$$

Bending stress at section A - A where  $y = -d_1 = -37.5 \text{ mm}$  becomes as

$$\begin{aligned} \sigma_{AA} &= -9.26 \left[ 1 + \frac{12.456 \times (-37.5)}{90 - 37.5} \right] \quad [\text{Substitute } y = -37.5 \text{ in equation (i)}] \\ &= 73.12 \text{ N/mm}^2 \end{aligned}$$

$\therefore$  Resultant stress at section A - A becomes as

$$(\sigma_r)_{AA} = \sigma_0 + \sigma_{AA} = 9.26 + 73.12 = 82.38 \text{ N/mm}^2 \text{ (Tensile). Ans.}$$

**Problem 23.6.** A hook carries a load  $P$  and the load line is at a distance of 30 mm from the inner edge of the central horizontal section which is of I-section with the dimensions shown in Fig. 23.15. The centre of curvature of the hook is in the load line. Determine the magnitude of the load  $P$  if the maximum stress in the hook is not to exceed the permissible stress of 120 N/mm<sup>2</sup>. What will be the maximum compressive stress in the hook for that value of the load?

Sol. Given :

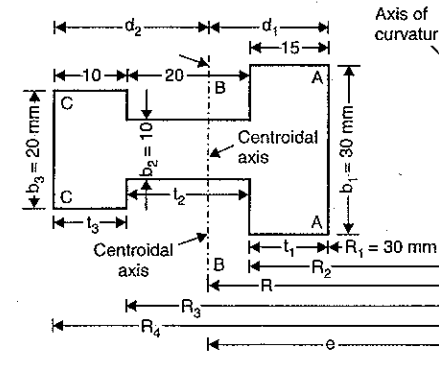

Fig. 23.15

Max. permissible stress,  $\sigma_r = 120 \text{ N/mm}^2$

As the load line passes through centre of curvature, the distance between load line and centroidal axis is equal to the distance between axis of curvature and centroidal axis.

or  $e = R$

Dimensions of I-section are

$$b_1 = 30 \text{ mm}, b_2 = 10 \text{ mm}, b_3 = 20 \text{ mm}$$

$$t_1 = 15 \text{ mm}, t_2 = 20 \text{ mm}, t_3 = 10 \text{ mm}$$

Also from Fig. 23.15

$$R_1 = 30 \text{ mm}$$

$$R_2 = 30 + 15 = 45 \text{ mm}, R_3 = R_2 + t_2 = 45 + 20 = 65 \text{ mm}$$

$$R_4 = R_3 + t_3 = 65 + 10 = 75 \text{ mm}$$

and

Area of cross-section,  $A = b_1t_1 + b_2t_2 + b_3t_3$   
 $= 30 \times 15 + 10 \times 20 + 20 \times 10$   
 $= 450 + 200 + 200 = 850 \text{ mm}^2$

Let us first find the location of centroidal axis. This can be done by taking moments of each areas about AA. Then

$$A \times d_1 = (30 \times 15) \times \frac{15}{2} + (10 \times 20) \times (15 + 10) + (20 \times 10) \times (15 + 20 + 5)$$

or  $850 \times d_1 = 3375 + 5000 + 8000$

$$\therefore d_1 = \frac{3375 + 13000}{850} = 19.26 \text{ mm}$$

$$d = 15 + 20 + 10 = 45$$

and  $d_2 = d - d_1 = 45 - 19.26 = 25.74 \text{ mm}$

Now  $R = R_1 + d_1 = 30 + 19.26 = 49.26 \text{ mm}$

Also  $e = R = 49.26 \text{ mm}$ .

Let us now find the value of  $h^2$  for I-section. It is given by equation (23.10) as the value

$$h^2 = \frac{R^3}{A} \left[ b_1 \log_e \left( \frac{R_2}{R_1} \right) + b_2 \log_e \left( \frac{R_3}{R_2} \right) + b_3 \log_e \left( \frac{R_4}{R_3} \right) \right] - R^2$$

$$= \frac{49.26^3}{850} \left[ 30 \log_e \left( \frac{45}{30} \right) + 10 \log_e \frac{65}{45} + 20 \log_e \left( \frac{75}{65} \right) \right] - 49.26^2$$

$$= 140.625 [30 \times 0.4054 + 10 \times 0.3677 + 20 \times 0.1431] - 2426.5$$

$$= 140.625 [12.16 + 3.677 + 2.862] - 2426.5 = 203.04$$

The bending stress at a distance  $y$  from centroidal axis is given by

$$\sigma_b = \frac{M}{A \times R} \left[ 1 + \frac{R^2}{h^2} \left( \frac{y}{R + y} \right) \right] \quad \dots(i)$$

Here  $M =$  Bending moment due to load  $P$

$$= -P \times e \text{ (-ve sign is used as applied load decreases the curvature of the hook).}$$

$$= -P \times 49.26 \text{ Nmm (where } e = R = 49.26 \text{ mm)}$$

Substituting the value of  $M$  and other known values in equation (i), we get

$$\sigma_b = \frac{-P \times 49.26}{850 \times 49.26} \left[ 1 + \frac{49.26^2}{203.04} \left( \frac{y}{49.26 + y} \right) \right]$$

$$= -1.176 \times 10^{-3} P \left[ 1 + 11.95 \left( \frac{y}{49.26 + y} \right) \right] \quad \dots(ii)$$

The bending stress will be maximum at section AA where  $y = -19.26 \text{ mm}$ . This stress will be tensile. Substituting  $y = -19.26$  in equation (ii), we get

$$\therefore (\sigma_b)_{\max} = -1.176 \times 10^{-3} P \left[ 1 + 11.95 \times \frac{(-19.26)}{(49.26 - 19.26)} \right]$$

$$= +7.846 \times 10^{-3} P \text{ N/mm}^2 \text{ (tensile)}$$

The direct stress,  $\sigma_0 = \frac{P}{A} = \frac{P}{850} \text{ N/mm}^2 \text{ (Tensile)}$

$\therefore$  Maximum resultant stress becomes as

$$(\sigma_r)_{\max} = \sigma_0 + (\sigma_b)_{\max} = \frac{P}{A} + 7.846 \times 10^{-3} P \text{ N/mm}^2$$

But this stress should not exceed the maximum permissible stress of  $120 \text{ N/mm}^2$

$$\therefore \frac{P}{850} + 7.846 \times 10^{-3} P = 120 \text{ or } P \left[ \frac{1}{850} + 7.846 \times 10^{-3} \right] = 120$$

or  $P \left[ \frac{1 + 850 \times 7.846 \times 10^{-3}}{850} \right] = 120 \text{ or } P \left[ \frac{1 + 6.6691}{850} \right] = 120$

$$\therefore P = \frac{120 \times 850}{7.6691} = 13,300 \text{ N} = 13.3 \text{ kN. Ans.}$$

**Maximum Compressive stress due to load,  $P = 13.3 \text{ kN}$**

The bending stress (compressive) will be maximum at the section C-C where  $y = d_2 = 25.74 \text{ mm}$ . Substituting the value of  $y = 25.74$  in equation (ii), we get maximum compressive bending stress.

$$\therefore \text{Compressive } (\sigma_b)_{\max} = -1.176 \times 10^{-3} \times 13300 \left[ 1 + 11.95 \times \left( \frac{25.74}{49.26 + 25.74} \right) \right]$$

(Here  $P = 13,300 \text{ N}$ )

$$= -79.78 \text{ N/mm}^2$$

Direct stress,  $\sigma_0 = \frac{P}{A} = \frac{13300}{850} = 15.64 \text{ N/mm}^2 \text{ (tensile)}$

$\therefore$  Maximum resultant compressive stress at C C

$$= \sigma_0 + (\sigma_b)_{\max} \text{ (compressive)}$$

$$= 15.64 - 79.78 = -64.13 \text{ N/mm}^2 \text{ (compressive). Ans.}$$

**Problem 23.7.** The curved member shown in Fig. 23.16 has a solid circular cross-section  $0.10 \text{ m}$  in diameter. If the maximum tensile and compressive stresses in the member are not to exceed  $150 \text{ MPa}$  and  $200 \text{ MPa}$  respectively, determine the value of load  $P$  that can safely be carried by the member.

(AMIE, Summer 1996)

**Sol. Given :**

Dia of section,  $d = 0.10 \text{ m}$

Max. tensile stress,

$$(\sigma_r)_t = 150 \text{ MPa} = 150 \times 10^6 \text{ N/m}^2$$

Max. compressive stress,

$$(\sigma_r)_c = 200 \text{ MPa} = 200 \times 10^6 \text{ N/m}^2$$

Refer to Fig. 23.16 (a)

Area of cross-section,

$$A = \frac{\pi}{4} d^2 = \frac{\pi}{4} (0.1)^2 = 7.854 \times 10^{-3} \text{ m}^2$$

$e =$  Eccentricity = distance between load line and centroidal axis

$$= 0.15 + 0.05 + 0.05 = 0.25 \text{ m}$$

$R =$  Radius of curvature

= distance between centre of curvature and centroidal axis

$$= 0.05 + 0.05 = 0.1 \text{ m}$$

Let us first find the value of  $h^2$  for circular section. It is given by equation (23.8) as

$$h^2 = \frac{d^2}{16} + \frac{1}{128} \times \frac{d^4}{R^2} + \dots$$

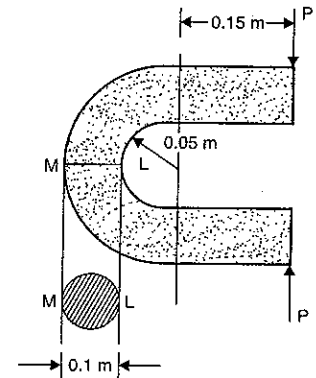

Fig. 23.16

$$= \frac{0.1^2}{16} + \frac{1}{128} \times \frac{0.1^4}{0.1^2}$$

$$= 7.031 \times 10^{-4} \text{ m}^2 \quad (\because R = 0.1 \text{ m also } d = 0.1 \text{ m})$$

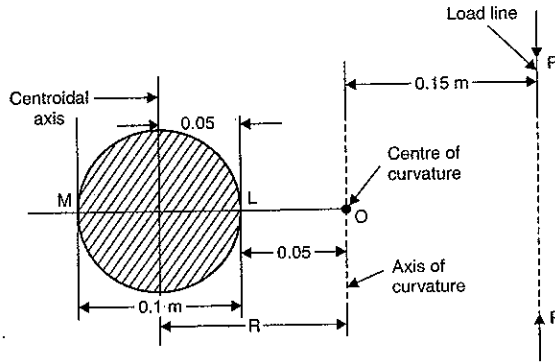

Fig. 23.16 (a)

Bending moment,  $M = P \times e$  (+ve sign is used as load  $P$  increases the curvature)  
 $= P \times 0.25 = 0.25 P \text{ Nm}$

The bending stress at any section at a distance  $y$  from centroidal axis is given by equation (23.1) as

$$\sigma_b = \frac{M}{A \times R} \left[ 1 + \frac{R^2}{h^2} \times \left( \frac{y}{R + y} \right) \right] \quad [\text{Here } \sigma_b = \sigma]$$

$$= \frac{0.25 P}{(7.854 \times 10^{-3}) \times 0.1} \left[ 1 + \frac{0.1^2}{7.031 \times 10^{-4}} \times \left( \frac{y}{0.1 + y} \right) \right] \quad \dots(i)$$

As the load  $P$  is compressive, hence direct stress ( $\sigma_0$ ) will be compressive at all points of the section.

$$\therefore \text{Direct stress, } \sigma_0 = \frac{P}{A} = \frac{P}{7.854 \times 10^{-3}} \text{ N/m}^2 \text{ (compressive)}$$

$$= - \frac{P}{7.854 \times 10^{-3}} \text{ (-ve sign due to compressive stress)}$$

$$= - 127.32 P$$

As the load is compressive, the bending stress will be compressive at the inner point  $L$  of the cross-section where  $y = - 0.05 \text{ m}$  and it will be tensile at the outer point  $M$  of the cross-section where  $y = 0.05 \text{ m}$ .

**1st Case.** Max. compressive bending stress will be obtained by substituting  $y = - 0.05 \text{ m}$  in equation (i).

$$\therefore \text{Compressive } (\sigma_b)_{\max} = \frac{0.25 P}{(7.854 \times 10^{-3} \times 0.1)} \left[ 1 + \frac{0.1^2}{7.031 \times 10^{-4}} \times \left( \frac{- 0.05}{0.1 - 0.05} \right) \right]$$

$$= 318.3 P [1 - 14.22] = - 4208.8 P$$

$$\therefore \text{Max. compressive stress, } (\sigma_r)_c = \sigma_0 + (\sigma_b)_{\max} \text{ (compressive)}$$

$$= - 127.32 P - 4208.8 P = - 4336.12 P.$$

But maximum compressive stress is given as  $200 \times 10^6 \text{ N/m}^2$

$$\therefore \text{Maximum compressive stress, } (\sigma_r)_c = - 200 \times 10^6 \text{ N/m}^2$$

(-ve sign is due to compressive stress)

$$\therefore - 200 \times 10^6 = - 4336.12 P$$

$$\therefore P = \frac{200 \times 10^6}{4336.12} = 46124 \text{ N} = 46.124 \text{ kN} \quad \dots(ii)$$

**2nd Case.** Max. tensile bending stress will be obtained by substituting  $y = + 0.05 \text{ m}$  in equation (i).

$$\therefore (\sigma_b)_{\max} \text{ (tensile)} = 318.3 P \left[ 1 + \frac{0.1^2}{7.031 \times 10^{-4}} \times \left( \frac{0.05}{0.1 + 0.05} \right) \right] = 1827.32 P$$

$$\therefore \text{Max. tensile stress, } (\sigma_r)_t = \sigma_0 + (\sigma_b)_{\max} \text{ (tensile)}$$

$$= - 127.32 P + 1827.32 P = 1700 P$$

But max tensile stress,  $(\sigma_r)_t = 150 \times 10^6 \text{ N/m}^2$  (given)

$$\therefore 1700 P = 150 \times 10^6$$

$$\therefore P = \frac{150 \times 10^6}{1700} = 88235.3 \text{ N} = 88.235 \text{ kN} \quad \dots(iii)$$

Comparing equations (ii) and (iii), the safe load will be lesser of the two.

$$\therefore P = 46.124 \text{ kN. Ans.}$$

### 23.7. STRESSES IN CIRCULAR RING

Fig. 23.17 (a) shows a circular ring subjected to a tensile load  $P$ . Cut the ring in two parts through  $A$  and  $B$  as shown in Fig. 23.17 (b). Fix the ends  $A$  and  $B$ . Now each half of the ring carries loads of  $\frac{1}{2} P$  and fixing moments  $M_0$  at the ends  $A$  and  $B$ . It is required to find the stresses in the ring. Due to symmetry, the stress distribution in the two halves of the ring will be the same.

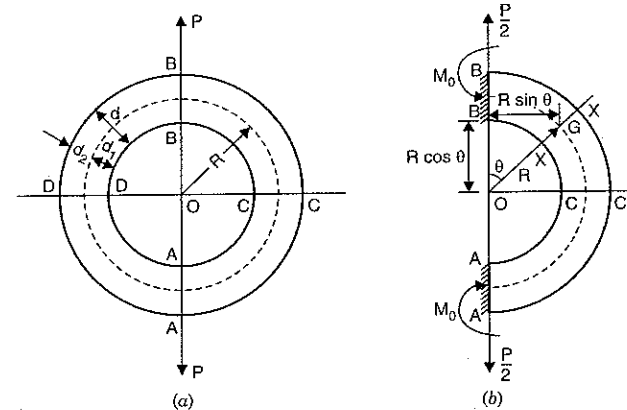

Fig. 23.17

Consider a section  $X - X$  at an angle  $\theta$  with the vertical.

Let  $M =$  bending moment with which the section  $X - X$  is subjected.

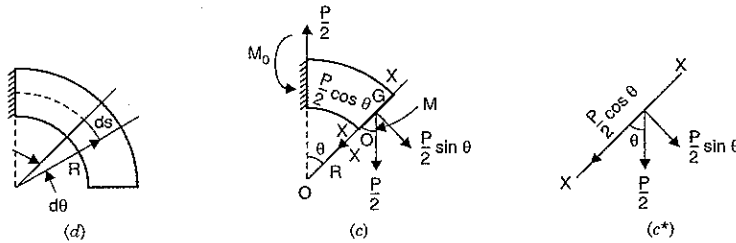

Fig. 23.17

If we know the value of  $M$ , then stresses can be calculated across the section  $X-X$ . But the determining the moment  $M$  at this section is statically indeterminate.

In case of straight beams which is subjected to transverse loading, there is bending moment and shear force at any section. The strain energy at any point is mainly due to bending. But a section of the curved beam has strain energy due to bending and also due to thrust. Here we assume the curved beam as the straight beam for determining  $M_0$  (and hence  $M$ ). So we neglect the effect of thrust in the calculation of strain energy.

Now, the bending moment ( $M$ ) with which the section  $X-X$  is subjected is given as

$$M = M_0 - \frac{P}{2} \times (R \sin \theta) \quad \dots(i)$$

where  $R$  = radius of the centre line of the ring.

Refer to free-body diagram shown in Fig. 23.17 (c) of the ring upto section  $X-X$ , the vertical downward force  $\frac{P}{2}$  has been resolved in two components, one along the radial direction ( $= \frac{P}{2} \cos \theta$ ) and other perpendicular to section  $X-X$  ( $= \frac{P}{2} \sin \theta$ ). The component  $\frac{P}{2} \times \sin \theta$  will produce direct stress ( $\sigma_0$ ) on the cross-section. There will be bending stress also acting on the cross-section. Only these two stresses are important and hence only they will be considered.

Direct stress, 
$$\sigma_0 = \frac{\frac{P}{2} \times \sin \theta}{A} = \frac{P}{2A} \times \sin \theta$$

Let us first find  $M_0$ . After that value of  $M$  will be obtained.

**Value of  $M_0$ .** The value of  $M_0$  is determined by using principle of minimum strain energy.

Strain energy will be minimum when  $\frac{\partial U}{\partial M_0} = 0$ . Hence according to principle of minimum strain energy

$$\therefore \frac{\partial U}{\partial M_0} = 0 \quad \dots(ii)$$

Refer to Fig. 23.17 (d).

Let a small element of length  $ds$  of the ring subtends an angle  $d\theta$  at the centre.

Then strain energy\* stored in length  $ds$  due to bending is given by

$$dU = \frac{1}{2} \frac{M^2}{EI} ds$$

Total strain energy stored in the half ring, is obtained by integrating the above equation.

$$\therefore U = \int_0^\pi \frac{1}{2} \times \frac{M^2}{EI} \times ds$$

Here  $E$  and  $I$  are constant. But  $M$  is variable.

Differentiating partially the above equation w.r.t.  $M_0$ , we get

$$\frac{\partial U}{\partial M_0} = \int_0^\pi \frac{1}{2EI} \times 2M \times \frac{\partial M}{\partial M_0} ds \quad \dots(iii)$$

Let us now find the value of  $\frac{\partial M}{\partial M_0}$ .

We know from equation (i) that

$$M = M_0 - \frac{1}{2} P \times (R \sin \theta)$$

Differentiating partially with respect to  $M_0$ , we get

$$\therefore \frac{\partial M}{\partial M_0} = 1 \quad (\text{For partial differentiation, only } M_0 \text{ is variable.})$$

Substituting this value in equation (iii), we get

$$\begin{aligned} \frac{\partial U}{\partial M_0} &= \int_0^\pi \frac{1}{2EI} \times 2M \times 1 \times ds = \int_0^\pi \frac{M}{EI} \times R d\theta \quad (\because ds = R d\theta) \\ &= \int_0^\pi \frac{\left( M_0 - \frac{1}{2} \times P \times R \sin \theta \right) \times R d\theta}{EI} \quad \left( \because M = M_0 - \frac{P}{2} \times R \sin \theta \right) \end{aligned}$$

But according to the principle of minimum strain energy,

$$\frac{\partial U}{\partial M_0} = 0$$

$$\therefore \int_0^\pi \frac{\left( M_0 - \frac{1}{2} \times P \times R \sin \theta \right) R \times d\theta}{EI} = 0 \text{ or } \int_0^\pi \left( M_0 - \frac{1}{2} \times P \times R \sin \theta \right) d\theta = 0$$

or 
$$\left[ M_0 \times \theta + \frac{1}{2} P \times R \times \cos \theta \right]_0^\pi = 0$$

\* $dU$  = Work done by B.M. = Average B.M.  $\times$  Change of angle =  $\frac{1}{2} M \times d\theta$ .

Length,  $ds = R \times d\theta \therefore d\theta = \frac{ds}{R}$ . Also  $\frac{M}{I} = \frac{E}{R} \therefore R = \frac{EI}{M}$ . Now

$$d\theta = \frac{ds}{R} = \frac{ds}{(EI/M)} = \frac{M ds}{EI}$$

$$\therefore dU = \frac{1}{2} M \times d\theta = \frac{1}{2} M \times \frac{M ds}{EI} = \frac{1}{2} \frac{M^2}{EI} ds.$$

$$\text{or } M_0(\pi - 0) + \frac{1}{2} \times P \times R \times [\cos \pi - \cos 0] = 0$$

$$\text{or } M_0 \times \pi + \frac{1}{2} \times P \times R \times [-1 - 1] = 0 \quad \text{or } M_0 \times \pi + \frac{1}{2} \times P \times R \times (-2) = 0$$

$$\therefore M_0 = \frac{P \times R}{\pi} = 0.318 P \times R$$

Now the value of bending moment  $M$  can be obtained by substituting  $M_0$  in equation (i),

as

$$M = M_0 - \frac{1}{2} \times P \times R \times \sin \theta = \frac{P \times R}{\pi} - \frac{1}{2} \times P \times R \times \sin \theta$$

$$\left[ \therefore M_0 = \frac{P \times R}{\pi} \right]$$

$$= P \times R \left( \frac{1}{\pi} - \frac{1}{2} \sin \theta \right) \quad \dots(23.12)$$

Value of  $M$  at section  $BB$  where  $\theta = 0$ , becomes

$$M_B = P \times R \left( \frac{1}{\pi} \right) = 0.318 \times P \times R$$

Value of  $M$  at section  $C-C$  is obtained by substituting

$$\theta = \frac{\pi}{2} \text{ in above equation,}$$

$$\therefore M \text{ at } C-C, M_C = P \times R \left( \frac{1}{\pi} - \frac{1}{2} \sin \frac{\pi}{2} \right) = P \times R \left( \frac{1}{\pi} - \frac{1}{2} \times 1 \right) \quad \left[ \therefore \sin \frac{\pi}{2} = 1 \right]$$

$$= P \times R [0.318 - 0.5] = -0.182 \times P \times R$$

The bending moment at  $\theta = 0$  is +ve whereas bending moment at  $\theta = \frac{\pi}{2}$  is -ve. This means  $M$  is zero between  $\theta = 0$  to  $\theta = 90^\circ$ . The value of  $\theta$ , where  $M$  is zero is obtained by substituting  $M = 0$  in equation (23.12),

$$0 = P \times R \times \left( \frac{1}{\pi} - \frac{1}{2} \sin \theta \right)$$

$$\text{or } \frac{1}{2} \sin \theta = \frac{1}{\pi} \quad \text{or } \sin \theta = \frac{2}{\pi} = 0.6366$$

$$\theta = 39.5^\circ$$

The bending moment ( $M$ ) can be obtained at any section of the ring. Now the bending stress can be determined from equation (23.1) as

$$\sigma_b = \frac{M}{A \times R} \left[ 1 + \frac{R^2}{h^2} \left( \frac{y}{R+y} \right) \right]$$

The bending stress will be maximum at the outer edge and inner edge of the cross-section where  $y = +d_2$  and  $y = -d_1$

where  $d_2$  = distance of the extreme outer edge from centre line

$d_1$  = distance of the extreme inner edge from centre line [Refer to Fig. 23.17 (a)]

The direct stress ( $\sigma_0$ ) will be due to pull  $\frac{P}{2} \times \sin \theta$

$$\therefore \sigma_0 = \frac{P}{2A} \times \sin \theta$$

The resultant stress ( $\sigma_r$ ) at any point will be equal to algebraic sum of direct stress and bending stress.

$$\therefore \sigma_r = \sigma_0 + \sigma_b$$

(i) Stresses when  $\theta = 0$

$$\text{Direct stress, } \sigma_0 = \frac{P}{2A} \times \sin \theta = \frac{P}{2A} \times \sin 0^\circ = 0$$

$$\text{Bending stress, } \sigma_b = \frac{M}{A \times R} \left[ 1 + \frac{R^2}{h^2} \left( \frac{y}{R+y} \right) \right]$$

where  $M$  = bending moment and given by equation (23.12) as

$$M = P \times R \left( \frac{1}{\pi} - \frac{1}{2} \sin \theta \right) = P \times R \times \left( \frac{1}{\pi} - 0 \right) = \frac{P \times R}{\pi}$$

$$\therefore \text{Resultant stress, } \sigma_r = \sigma_0 + \sigma_b$$

(ii) Stresses when  $\theta = \frac{\pi}{2} = 90^\circ$

$$\text{Direct stress, } \sigma_0 = \frac{P}{2A} \sin 90^\circ = \frac{P}{2A}$$

$$\text{Bending stress, } \sigma_b = \frac{M}{A \times R} \left[ 1 + \frac{R^2}{h^2} \left( \frac{y}{R+y} \right) \right]$$

$$\text{where } M = P \times R \left( \frac{1}{\pi} - \frac{1}{2} \sin \theta \right) = P \times R \left( \frac{1}{\pi} - \frac{1}{2} \sin 90^\circ \right) = P \times R \left( \frac{1}{\pi} - 0.5 \right)$$

Hence resultant stress,

$$\sigma_r = \sigma_0 + \sigma_b$$

**Problem 23.8.** A closed ring of mean radius of curvature 90 mm is subjected to a pull of 3 kN. The line of action of the load passes through the centre of the ring. Calculate the maximum tensile and compressive stresses in the material of the ring if the ring is circular in cross-section with diameter equal to 15 mm.

**Sol.** Given :

Mean radius of curvature of closed ring,  $R = 90$  mm

Pull,  $P = 3$  kN =  $3 \times 1000$  N = 3000 N

Cross-section of ring is circular with  $d = 15$  mm

$$\therefore r = \frac{d}{2} = \frac{15}{2} = 7.5 \text{ mm}$$

$$\therefore \text{Area of cross-section, } A = \frac{\pi}{4} d^2 = \frac{\pi}{4} \times 15^2 = 176.70 \text{ mm}^2$$

$$\text{Direct stress is given by, } \sigma_0 = \frac{P}{2A} \times \sin \theta \quad \dots(i)$$

The bending stress ( $\sigma_b$ ) is given by,

$$\sigma_b = \frac{M}{A \times R} \left[ 1 + \frac{R^2}{h^2} \times \left( \frac{y}{R+y} \right) \right] \quad \dots(ii)$$

where  $M$  = bending moment and is given by equation (23.12)

$$= P \times R \left( \frac{1}{\pi} - \frac{1}{2} \sin \theta \right) \quad \dots(iii)$$

Let us find first the value of  $h^2$  for circular section. It is given by equation (23.8) as

$$h^2 = \frac{d^2}{16} + \frac{1}{128} \frac{d^4}{R^2} + \dots$$

where  $d$  = Dia. of circular cross-section  
= 15 mm here  
 $R$  = Radius of curvature  
= 90 mm here

$$= \frac{15^2}{16} + \frac{1}{128} \times \frac{15^4}{90^2}$$

$$= 14.0625 + 0.0488 = 14.1113 \approx 14.11$$

(i) Stresses when  $\theta = 0^\circ$ . From equation, (i), the direct stress,

$$\sigma_0 = \frac{P}{2A} \times \sin 0^\circ = 0$$

Bending moment from equation (iii),

$$M = P \times R \left( \frac{1}{\pi} - \frac{1}{2} \times \sin 0^\circ \right) = P \times R \times \left( \frac{1}{\pi} - 0 \right)$$

$$= \frac{P \times R}{\pi} = \frac{3000 \times 90}{\pi} \text{ Nmm} = 85943 \text{ Nmm}$$

Bending stress ( $\sigma_b$ ) from equation (ii),

$$\sigma_b = \frac{M}{A \times R} \left[ 1 + \frac{R^2}{h^2} \times \left( \frac{y}{R+y} \right) \right]$$

$$= \frac{85943}{176.7 \times 90} \left[ 1 + \frac{90^2}{14.11} \times \frac{y}{(90+y)} \right]$$

[ $\because A = 176.7 \text{ mm}^2$  and  $h^2 = 14.11$ ]

The bending stress at the outer most edge of the cross-section where  $y = \frac{d}{2} = \frac{15}{2} = 7.5 \text{ mm}$

is given by

$$(\sigma_b)_0 = \frac{85943}{176.7 \times 90} \left[ 1 + \frac{90^2}{14.11} \left( \frac{7.5}{90+7.5} \right) \right] = 244 \text{ N/mm}^2 \text{ (tensile)}$$

The bending stress at the inner most edge of the cross-section where  $y = -\frac{d}{2} = -7.5 \text{ mm}$ .

$$(\sigma_b)_i = \frac{85943}{176.7 \times 90} \left[ 1 + \frac{90^2}{14.11} \left( \frac{-7.5}{90-7.5} \right) \right]$$

$$= -276.6 \text{ N/mm}^2 \text{ (compressive)}$$

$\therefore$  Resultant stress at the outer-most edge,

$$(\sigma_r)_0 = \sigma_0 + (\sigma_b)_0 = 0 + 244 = 244 \text{ N/mm}^2 \text{ (tensile)}$$

Similarly resultant stress at the inner most edge,

$$(\sigma_r)_i = \sigma_0 + (\sigma_b)_i = 0 - 276.6 = -276.6 \text{ N/mm}^2 \text{ (compressive)}$$

Ans

(ii) Stresses when  $\theta = 90^\circ = \frac{\pi}{2}$

Direct stress,  $\sigma_0 = \frac{P}{2A} \times \sin 90^\circ = \frac{P}{2A}$

$$= \frac{3000}{2 \times 176.7} = 8.49 \text{ N/mm}^2 \text{ (tensile)}$$

Bending moment,  $M = P \times R \left( \frac{1}{\pi} - \frac{1}{2} \times \sin 90^\circ \right)$

$$= 3000 \times 90 \left( \frac{1}{\pi} - \frac{1}{2} \right) = 270000 (0.3183 - 0.5) = -49059 \text{ Nmm}$$

$$\therefore \sigma_b = \frac{M}{A \times R} \left[ 1 + \frac{R^2}{h^2} \times \left( \frac{y}{R+y} \right) \right] = \frac{-49059}{176.7 \times 90} \left[ 1 + \frac{90^2}{14.11} \times \left( \frac{y}{90+y} \right) \right]$$

$$= -3.085 \left[ 1 + 574 \times \left( \frac{y}{90+y} \right) \right]$$

The bending stress at outer-most edge where  $y = 7.5 \text{ mm}$ ,

$$(\sigma_b)_0 = -3.085 \left[ 1 + 574 \times \left( \frac{7.5}{90+7.5} \right) \right] = -139.3 \text{ N/mm}^2 \text{ (compressive)}$$

The bending stress at inner most edge where  $y = -7.5 \text{ mm}$ ,

$$(\sigma_b)_i = -3.085 \left[ 1 + 574 \times \left( \frac{-7.5}{90-7.5} \right) \right] = 157.9 \text{ N/mm}^2 \text{ (tensile)}$$

$\therefore$  Resultant stress at outer most edge,

$$(\sigma_r)_0 = \sigma_0 + (\sigma_b)_0$$

$$= 8.49 + (-139.3) = -130.81 \text{ N/mm}^2 \text{ (compressive)}$$

Resultant stress at inner most edge,

$$(\sigma_r)_i = \sigma_0 + (\sigma_b)_i = 8.49 + 157.9 = 166.39 \text{ N/mm}^2 \text{ (tensile)}$$

Comparing the resultant stresses when  $\theta = 0$  and when  $\theta = \frac{\pi}{2}$ , we get

Maximum tensile stress = 244 N/mm<sup>2</sup>. Ans.

Maximum compressive stress = 276.6 N/mm<sup>2</sup>. Ans.

### 23.8. STRESSES IN A CHAIN LINK

A chain link consists of two parts. One part at the middle is a straight portion of length  $L$ , whereas the other part at the ends is semi-circular as shown in Fig. 23.18.

The stresses in the link can be determined by the same method as applied to circular ring.

Let  $L$  = Length of the straight portion of the link

$R$  = Mean radius of curvature of the circular portion

$P$  = Pull on the chain link

$M$  = B.M. at any section in the circular portion

$M_1$  = B.M. at any section in the straight portion



Consider half portion of the link, subjected to pull  $P/2$  as shown in Fig. 22.18 (b). Let  $M_0$  = fixing end moments at section  $BB$ . Consider any section  $X-X$  making an angle  $\theta$  with vertical section  $BB$ .

The bending moment ( $M$ ) at the section  $X-X$  in the circular portion is given by

$$M = M_0 - \frac{P}{2} \times R \sin \theta \quad \dots(i)$$

At section  $A-A$  where  $\theta = \frac{\pi}{2} = 90^\circ$ , the above bending moment becomes,

$$M = M_0 - \frac{P}{2} \times R \times \sin 90^\circ = M_0 - \frac{P}{2} \times R \quad \dots(ii)$$

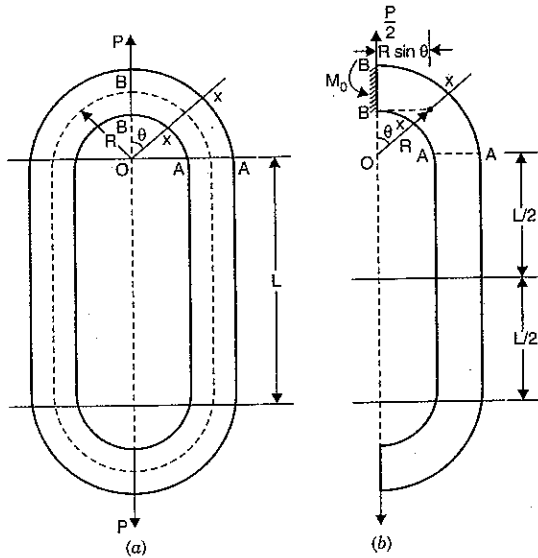

Fig. 23.18

As the section  $AA$  is common to circular portion and straight portion, hence B.M. for straight portion =  $M_0 - \frac{P}{2} \times R$ .

**Value of  $M_0$ .** Now the total strain energy stored in half portion of link is equal to the strain energy stored in circular portion plus strain energy stored in straight portion.

or 
$$U = 2 \int_0^{\pi/2} (dU)_{\text{circular}} + 2 \int_0^{L/2} (dU)_{\text{straight}}$$

[ In half portion of link, there are two circular ends (from angle  $0$  to  $\frac{\pi}{2}$ ) and one straight portion of length  $L$  (or two straight portions of lengths  $0$  to  $\frac{L}{2}$ ) ]

or 
$$U = 2 \int_0^{\pi/2} \frac{M^2}{2EI} ds + 2 \int_0^{L/2} \frac{M^2}{2EI} dx$$

Differentiating partially the above equation w.r.t.,  $M_0$ , we get

$$\frac{\partial U}{\partial M_0} = \frac{2}{2EI} \left[ \int_0^{\pi/2} (2M) \times \frac{\partial M}{\partial M_0} \times ds + \int_0^{L/2} (2M) \times \frac{\partial M}{\partial M_0} dx \right]$$

The strain energy will be minimum if  $\frac{\partial U}{\partial M_0} = 0$

Hence for minimum strain energy,

$$\frac{2}{2EI} \left[ \int_0^{\pi/2} (2M) \times \frac{\partial M}{\partial M_0} \times ds + \int_0^{L/2} (2M) \frac{\partial M}{\partial M_0} dx \right] = 0$$

or 
$$\int_0^{\pi/2} (2M) \times \frac{\partial M}{\partial M_0} ds + \int_0^{L/2} (2M) \frac{\partial M}{\partial M_0} dx = 0$$

or 
$$\int_0^{\pi/2} M \frac{\partial M}{\partial M_0} ds + \int_0^{L/2} M \frac{\partial M}{\partial M_0} dx = 0 \quad \dots(iii)$$

For circular portion,  $M = M_0 - \frac{P \times R}{2} \sin \theta$

$\therefore \frac{\partial M}{\partial M_0} = 1$  (For partial differentiation, only  $M_0$  is variable)

and also  $ds = R \times d\theta$

$$\begin{aligned} \therefore \int_0^{\pi/2} M \frac{\partial M}{\partial M_0} \times ds &= \int_0^{\pi/2} \left( M_0 - \frac{P \times R}{2} \sin \theta \right) \times 1 \times R d\theta \\ &= R \left( M_0 \times \theta + \frac{PR}{2} \cos \theta \right)_0^{\pi/2} \\ &= R \left[ M_0 \left( \frac{\pi}{2} - 0 \right) + \frac{PR}{2} \left( \cos \frac{\pi}{2} - \cos 0^\circ \right) \right] \\ &= R \left[ M_0 \times \frac{\pi}{2} + \frac{PR}{2} (0 - 1) \right] = R \left[ M_0 \times \frac{\pi}{2} - \frac{P \times R}{2} \right] \quad \dots(iv) \end{aligned}$$

For straight portion,

$$M = M_0 - \frac{P \times R}{2}$$

$\therefore \frac{\partial M}{\partial M_0} = 1$

$$\begin{aligned} \therefore \int_0^{L/2} M \frac{\partial M}{\partial M_0} dx &= \int_0^{L/2} \left( M_0 - \frac{P \times R}{2} \right) \times 1 \times dx \\ &= \int_0^{L/2} \left( M_0 - \frac{PR}{2} \right) dx = \left[ \left( M_0 - \frac{PR}{2} \right) \times x \right]_0^{L/2} \\ &= \left( M_0 - \frac{PR}{2} \right) \times \frac{L}{2} \quad \dots(v) \end{aligned}$$

Substituting equations (iv) and (v) in equation (iii), we get

$$R \left[ M_0 \times \frac{\pi}{2} - \frac{P \times R}{2} \right] + \left( M_0 - \frac{P \times R}{2} \right) \times \frac{L}{2} = 0$$

$$M_0 \times R \times \frac{\pi}{2} - \frac{P \times R^2}{2} + M_0 \times \frac{L}{2} - \frac{P \times R}{2} \times \frac{L}{2} = 0$$

$$M_0 \left( R \times \frac{\pi}{2} + \frac{L}{2} \right) - \frac{PR}{2} \left( R + \frac{L}{2} \right) = 0$$

$$M_0 \left( R \times \frac{\pi}{2} + \frac{L}{2} \right) = \frac{PR}{2} \left( R + \frac{L}{2} \right)$$

$$\frac{M_0}{2} (R \times \pi + L) = \frac{P \times R}{2} \left( R + \frac{L}{2} \right)$$

$$M_0 (\pi R + L) = P \times R \left( R + \frac{L}{2} \right) \quad \left[ \text{Cancelling } \frac{1}{2} \right]$$

$$\begin{aligned} M_0 &= \frac{P \times R (2R + L)}{2(\pi R + L)} \\ &= \frac{P \times R}{2} \left( \frac{2R + L}{\pi R + L} \right) \end{aligned} \quad \dots(23.13)$$

Substituting this value of  $M_0$  in equation (i), we get the moment at any section in the curved portion as

$$\begin{aligned} M &= \frac{P \times R}{2} \left( \frac{2R + L}{\pi R + L} \right) - \frac{P}{2} \times R \sin \theta \\ &= \frac{P \times R}{2} \left[ \frac{2R + L}{\pi R + L} - \sin \theta \right] \end{aligned} \quad \dots(23.14)$$

When  $\theta = \frac{\pi}{2} = 90^\circ$  (i.e., at section AA) this moment becomes as

$$\begin{aligned} M &= \frac{P \times R}{2} \left( \frac{2R + L}{\pi R + L} - 1 \right) = \frac{P \times R}{2} \left( \frac{2R + L - \pi R - L}{\pi R + L} \right) \\ &= \frac{P \times R}{2} \left( \frac{2R - \pi R}{\pi R + L} \right) \end{aligned} \quad \dots(23.15)$$

As  $\pi R$  is more than  $2R$ , hence the term  $(2R - \pi R)$  is -ve. Hence the bending moment at section AA will be negative. The equation (23.15) also gives the bending moment in the straight portion. Once the bending moments in the curved portion and in the straight portion are known, the bending stresses can easily be calculated. These portions will also be subjected to direct stresses due to pull of  $\frac{P}{2} \sin \theta$  in the curved portion and a pull of  $\frac{P}{2}$  in the straight portion.

#### Stresses in the Curved Portion

The stress at any section is the algebraic sum of direct stress and bending stress.

$$\sigma_r = \sigma_0 + \sigma_b$$

$$\therefore \text{where } \sigma_0 = \frac{P}{2A} \times \sin \theta \quad \dots(23.16)$$

$$\text{and } \sigma_b = \frac{M}{A \times R} \left[ 1 + \frac{R^2}{h^2} \times \left( \frac{y}{R + y} \right) \right]$$

$$\text{where } M = \frac{P \times R}{2} \left[ \frac{2R + L}{\pi R + L} - \sin \theta \right] \quad \dots(23.17)$$

At any section, there will two maximum values of  $(\sigma_b)$ .

One value will be at  $y = +d_2$  and other value will be at

$$y = -d_1.$$

Here  $d_2$  = distance of extreme outer edge of the section from centre line of curved portion

and  $d_1$  = distance of extreme inner edge of the section from centre line.

#### Stresses in Straight Portion

Here  $\sigma_0$  = direct stress

$$= \frac{P}{2A} \quad \dots(23.18)$$

$\sigma_b$  = bending stress

$$= \frac{M}{I} \times y \quad \text{where } M = \frac{P \times R}{2} \left( \frac{2R - \pi R}{\pi R + L} \right) \quad \dots(23.19)$$

Here also  $y = +d_2$  and  $y = -d_1$

$\sigma_r$  = resultant stress

$$= \sigma_0 + \sigma_b.$$

**Problem 23.9.** A pull of 25 kN is applied to a simple chain link shown in Fig. 23.19. The mean radius of curvature of the semi-circular ends is 40 mm. The link is circular in cross-section with radius = 20 mm. If the length of straight portion is 40 mm, determine the stresses in the link.

**Sol. Given :**

$$P = 25 \text{ kN} = 25 \times 1000 \text{ N}$$

$$R = 40 \text{ mm}$$

Cross-section of link is circular with  $r = 20 \text{ mm}$

$$\therefore d = 2r = 2 \times 20 = 40 \text{ mm}$$

$$L = 40 \text{ mm}$$

Area of cross-section,  $A = \pi r^2$

$$= \pi \times 20^2 \text{ mm}^2$$

$$= 400\pi \text{ mm}^2 = 1256.6 \text{ mm}^2$$

Let us find the value of  $h^2$  for circular section. It is given by equation (23.8) as

$$\begin{aligned} h^2 &= \frac{d^2}{16} + \frac{1}{128} \frac{d^4}{R^2} + \dots \\ &= \frac{40^2}{16} + \frac{1}{128} \times \frac{40^4}{40^2} \\ &= 100 + 12.5 = 112.5 \end{aligned}$$

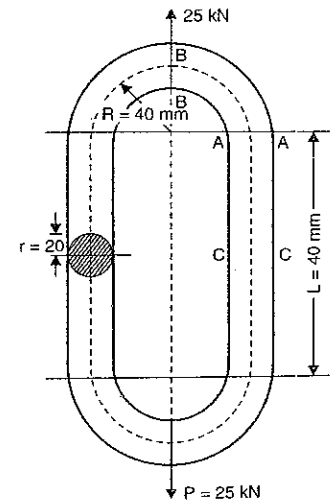

Fig. 23.19

(i) Stresses in curved portion

(a) At  $\theta = 0$  i.e., section BB

$$\text{Direct stress, } \sigma_0 = \frac{P}{2A} \times \sin \theta = 0$$

$$\text{Bending stress, } \sigma_b = \frac{M}{A \times R} \left[ 1 + \frac{R^2}{h^2} \left( \frac{y}{R+y} \right) \right]$$

where  $M$  = bending moment in curved portion and is given by equation (23.14) as

$$\begin{aligned} M &= \frac{P \times R}{2} \left( \frac{2R+L}{\pi R+L} - \sin \theta \right) \\ &= \frac{P \times R}{2} \left( \frac{2R+L}{\pi R+L} - \sin 0^\circ \right) \quad (\text{at } \theta = 0^\circ) \\ &= \frac{P \times R}{2} \left( \frac{2R+L}{\pi R+L} \right) = \frac{25000 \times 40}{2} \left( \frac{2 \times 40 + 40}{\pi \times 40 + 40} \right) \\ &= 362187.6 \text{ Nmm} \end{aligned}$$

$$\begin{aligned} \therefore \sigma_b &= \frac{362187.6}{1256.6 \times 40} \left[ 1 + \frac{40^2}{112.5} \left( \frac{y}{40+y} \right) \right] \\ &= 7.205 \left[ 1 + 14.22 \left( \frac{y}{40+y} \right) \right] \end{aligned}$$

Bending stress at the extreme outer edge where  $y = r = +20$  mm

$$\therefore (\sigma_b)_0 = 7.205 \left[ 1 + 14.22 \left( \frac{20}{40+20} \right) \right] = 41.35 \text{ N/mm}^2$$

$\therefore$  Resultant stress at the extreme outer edge,

$$\begin{aligned} (\sigma_r)_0 &= \sigma_0 + (\sigma_b)_0 \\ &= 0 + 41.35 = 41.35 \text{ N/mm}^2 \text{ (tensile). Ans.} \end{aligned}$$

Bending stress at the extreme inner edge where  $y = r = -20$  mm,

$$\begin{aligned} (\sigma_b)_i &= 7.205 \left[ 1 + 14.22 \left( \frac{-20}{40-20} \right) \right] \\ &= -95.25 \text{ N/mm}^2 \text{ (compressive)} \end{aligned}$$

$\therefore$  Resultant stress at the extreme inner edge,

$$\begin{aligned} (\sigma_r)_i &= \sigma_0 + (\sigma_b)_i \\ &= 0 + (-95.25) = -95.25 \text{ N/mm}^2 \text{ (compressive). Ans.} \end{aligned}$$

(b) at  $\theta = 90^\circ$  i.e., section AA

$$\begin{aligned} \sigma_0 &= \text{direct stress} \\ &= \frac{P}{2A} \times \sin \theta = \frac{P}{2A} \times \sin 90^\circ = \frac{P}{2A} \\ &= \frac{25000}{2 \times 1256.6} = 9.95 \text{ N/mm}^2 \text{ (tensile)} \\ \sigma_b &= \text{bending stress} \end{aligned}$$

$$= \frac{M}{A \times R} \left[ 1 + \frac{R^2}{h^2} \left( \frac{y}{R+y} \right) \right]$$

where

$$\begin{aligned} M &= \frac{P \times R}{2} \left( \frac{2R+L}{\pi R+L} - \sin 90^\circ \right) \\ &= \frac{P \times R}{2} \left( \frac{2R+L}{\pi R+L} - 1 \right) \\ &= \frac{25000 \times 40}{2} \left( \frac{2 \times 40 + 40}{\pi \times 40 + 40} - 1 \right) \\ &= 500000 (0.724 - 1) = -137812 \text{ Nmm.} \\ &= \frac{-137812}{1256.6 \times 40} \left[ 1 + \frac{40^2}{112.5} \left( \frac{y}{40+y} \right) \right] \\ &= -2.74 \left[ 1 + 14.22 \left( \frac{y}{40+y} \right) \right] \end{aligned}$$

Bending stress at outer edge where  $y = 20$  mm

$$\begin{aligned} (\sigma_b)_0 &= -2.74 \left[ 1 + 14.22 \times \left( \frac{20}{40+20} \right) \right] \\ &= -15.73 \text{ N/mm}^2 \text{ (compressive)} \end{aligned}$$

Resultant stress at outer edge

$$\begin{aligned} \therefore (\sigma_r)_0 &= \sigma_0 + (\sigma_b)_0 \\ &= 9.95 + (-15.73) = -5.78 \text{ N/mm}^2 \text{ (compressive). Ans.} \end{aligned}$$

Bending stress at the inner edge where  $y = -20$  mm,

$$\begin{aligned} (\sigma_b)_i &= -2.74 \left[ 1 + 14.22 \left( \frac{-20}{40-20} \right) \right] \\ &= 36.22 \text{ N/mm}^2 \text{ (tensile)} \end{aligned}$$

$\therefore$  Resultant stress at the inner edge,

$$\begin{aligned} (\sigma_r)_i &= \sigma_0 + (\sigma_b)_i \\ &= 9.95 + 36.22 = 46.17 \text{ N/mm}^2 \text{ (tensile). Ans.} \end{aligned}$$

(ii) Stresses in straight portion

Here

$$\begin{aligned} \sigma_0 &= \text{direct stress} \\ &= \frac{P}{2A} = \frac{25000}{2 \times 1256.6} = 9.95 \text{ N/mm}^2 \text{ (tensile)} \\ \sigma_b &= \text{bending stress} \\ &= \frac{M}{I} \times y \end{aligned}$$

where  $M$  = bending moment

$$= \frac{P \times R}{2} \left( \frac{2R+L}{\pi R+L} - 1 \right) = -137812 \text{ Nmm (Already calculated)}$$

$$I = \text{M.O.I.} = \frac{\pi}{64} d^4 = \frac{\pi}{64} \times 40^4 \text{ mm}^2$$

$$\sigma_b = \frac{-137812}{\frac{\pi}{64} \times 40^4} \times y$$

The bending stress at any point on outer edge of straight portion where  $y = +20$  mm,

$$(\sigma_b)_o = \frac{-137812 \times 64}{\pi \times 40^4} \times 20 = -21.93 \text{ N/mm}^2 \text{ (compressive)}$$

The bending stress at any point on inner edge of straight portion where  $y = -20$  mm,

$$(\sigma_b)_i = \frac{-137812 \times 64}{\pi \times 40^4} \times (-20) = +21.93 \text{ N/mm}^2 \text{ (tensile)}$$

$\therefore$  Total stress at any point on outer edge of straight portion is,

$$(\sigma_r)_o = \sigma_o + (\sigma_b)_o = 9.95 + (-21.93) \\ = -11.98 \text{ N/mm}^2 \text{ (compressive). Ans.}$$

And total stress at any point on inner edge of the straight portion is,

$$(\sigma_r)_i = \sigma_o + (\sigma_b)_i = 9.95 + 21.93 = 31.88 \text{ N/mm}^2 \text{ (tensile). Ans.}$$

The maximum compressive stress in the link is  $95.25 \text{ N/mm}^2$  at the inner edge of curved portion where load is applied and maximum tensile stress is  $46.17 \text{ N/mm}^2$  just at the junction of curved and straight portion at the inner edge.

### HIGHLIGHTS

- The stress at any point in case of curved bar subjected to a bending moment is given by,

$$\sigma = \frac{M}{R \times A} \left[ 1 + \frac{R^2}{h^2} \left( \frac{y}{R+y} \right) \right]$$

where  $\sigma$  = Bending stress (i.e.,  $\sigma_b$ )

$M$  = Bending moment with which the bar is subjected

$R$  = Radius of curvature of curved bar, or it is the distance of axis of curvature from centroidal axis

$A$  = Area of cross-section

$y$  = Distance of any point from centroidal axis

$h^2$  = is a constant for a cross-section

$$= \frac{1}{A} \int \frac{y^2 dA}{\left( 1 + \frac{y}{R} \right)}$$

- The distance of neutral axis from centroidal axis is given by,

$$y_o = - \frac{R \times h^2}{(R^2 + h^2)}$$

-ve sign shows that neutral axis is below the centroidal axis.

- The value of  $h^2$  for different cross-sections is given as :

(i) For rectangular section :

$$h^2 = \frac{R^3}{d} \left[ \log_e \left( \frac{2R+d}{2R-d} \right) \right] - R^2 = R^2 \left[ \frac{1}{3} \left( \frac{d}{2R} \right)^2 + \frac{1}{5} \left( \frac{d}{2R} \right)^4 + \dots \right]$$

where  $d$  = Depth of section,

$R$  = Radius of curvature or distance of axis of curvature from centroidal axis.

The value of ' $h^2$ ' is independent of width ' $b$ '

(ii) For triangular section.

$$(a) h^2 = \frac{2R^3}{d^2} \left[ R_2 \log_e \left( \frac{R_2}{R_1} \right) - (R_2 - R_1) \right] - R^2$$

where  $R_2$  = Distance of apex of triangle from axis of curvature

$R_1$  = Distance of base of triangle from axis of curvature

$d$  = Depth or height of triangle

(b) The value of  $h^2$  for triangular section, in terms of  $R$  and  $d$  is also given as :

$$h^2 = \frac{2R^3}{d^2} \left[ \left( \frac{3R+2d}{3} \right) \left\{ \log_e \left( \frac{3R+2d}{3R-d} \right) \right\} - d \right] - R^2$$

(iii) For trapezoidal section.

$$h^2 = \frac{R^3}{A} \left[ \left\{ b_2 + \left( \frac{b_1 - b_2}{d} \right) \times R_2 \right\} \log_e \left( \frac{R_2}{R_1} \right) - (b_1 - b_2) \right] - R^2$$

where  $b_1$  = Width of section at base,

$b_2$  = Width of section at top,

$d$  = Depth of trapezoidal section

$R_2$  = Distance of top layer of section from axis of curvature

$R_1$  = Distance of bottom layer of section from axis of curvature

(iv) For circular section :

$$h^2 = \frac{d^2}{16} + \frac{1}{128} \frac{d^4}{R^2} + \dots$$

$d$  = Diameter of circular section,

$R$  = Radius of curvature of curved bar.

(v) For T-section :

$$h^2 = \frac{R^3}{A} \left[ b_2 \log_e \left( \frac{R_3}{R_2} \right) + b_1 \log_e \left( \frac{R_2}{R_1} \right) \right] - R^2$$

where  $A$  = area of T-section

$$= b_1 \times t_1 + b_2 \times t_2$$

$$= b_1 \times (R_2 - R_1) + b_2 \times (R_3 - R_2)$$

where  $R_1$  = Distance of bottom layer of base from axis of curvature

$R_2$  = Distance of top layer of base from axis of curvature

$R_3$  = Distance of top layer of T-section from axis of curvature

$b_1$  = Width of base of T-section

$b_2$  = Width of top of T-section.

(vi) For I-section :

$$h^2 = \frac{R^3}{A} \left[ b_1 \log_e \left( \frac{R_2}{R_1} \right) + b_2 \log_e \left( \frac{R_3}{R_2} \right) + b_3 \log_e \left( \frac{R_4}{R_3} \right) \right] - R^2$$

where  $A = b_1 \times t_1 + b_2 \times t_2 + b_3 \times t_3$ .

- Resultant stress in a curved bar subject to direct stress and bending stress is given by

$$\sigma_r = \sigma_o + \sigma_b$$

$$\text{where } \sigma_b = \frac{M}{A \times R} \left[ 1 + \frac{R^2}{h^2} \left( \frac{y}{R+y} \right) \right]$$

$y$  is positive and maximum at top layer and is -ve and maximum at bottom layer. Also

$y$  = distance of any layer from centroidal axis.

5. Resultant stress in a circular ring :

$$\sigma_r = \sigma_0 + \sigma_b \quad \text{where} \quad \sigma_0 = \frac{P}{2A} \times \sin \theta$$

and

$$\sigma_b = \frac{M}{A \times R} \left[ 1 + \frac{R^2}{h^2} \left( \frac{y}{R+y} \right) \right]$$

where  $M$  = bending moment

$$= P \times R \left[ \frac{1}{\pi} - \frac{1}{2} \sin \theta \right]$$

6. Resultant stress in a chain link

$$\sigma_r = \sigma_0 + \sigma_b$$

where  $\sigma_0 = \frac{P}{2A} \times \sin \theta$  ... for circular portion

$$= \frac{P}{2A} \dots \text{for straight portion}$$

$\sigma_b$  = bending stress ...for circular portion

$$= \frac{M}{A \times R} \left[ 1 + \frac{R^2}{h^2} \times \left( \frac{y}{R+y} \right) \right]$$

and  $M$  = bending moment

$$= \frac{P \times R}{2} \left[ \frac{2R+L}{\pi R+L} - \sin \theta \right] \dots \text{For circular portion}$$

$\sigma_b$  = for straight portion

$$= \frac{M}{I} \times y$$

where  $M = \frac{P \times R}{2} \left[ \frac{2R+L}{\pi R+L} - 1 \right]$  and  $I = \text{M.O. Inertia.}$

### EXERCISE 23

#### (A) Theoretical Questions

- (a) What are the assumptions made in the derivation of stresses in a curved bar which is subjected to bending moments ?  
(b) Find an expression for bending stress produced in a curved bar which is subjected to bending moment.
- Write-down the expression for Winkler-Bach formula.
- Prove that the position of neutral axis from centroid axis is given by

$$y_0 = - \frac{R \times h^2}{(R^2 + h^2)}$$

where  $R$  = radius of curvature of curved bar or distance of axis of curvature from centroidal axis  
 $h^2$  = a constant which depends upon the shape of cross-section.

- Find an expression for  $h^2$  for the following cross-sections  
(i) rectangular section (ii) circular section (iii) trapezoidal section and (iv)  $I$  and  $T$ -sections.
- Write an expression for resultant stresses in a curved member subjected to direct stress and bending stress.
- Find an expression for the bending moment in a circular ring which is subjected to a tensile load  $P$  along the diameter.

7. Prove that bending moment ( $M$ ) is a simple chain link for curved portion is given by,

$$M = \frac{P \times R}{2} \left( \frac{2R+L}{\pi R+L} - \sin \theta \right)$$

8. Explain in details the procedure of finding resultant stress in case of :  
(a) circular ring and  
(b) chain link

When they are subjected to a tensile load along the longitudinal axis.

#### (B) Numerical Problems

1. Determine : (i) location of neutral axis, (ii) maximum and minimum stresses and (iii) ratio of maximum and minimum stress,

When a curved beam of rectangular cross-section of width 10 mm and depth 20 mm is subjected to pure bending of moment + 50 Nm. The beam is curved in a plane parallel to depth. The mean radius of curvature is 25 mm. Also plot the variation of stresses across the section.

[Ans. (i)  $y_0 = -1.39$  mm (ii) 1.76 (iii) 103 N/mm<sup>2</sup> (comp.) and 58.45 N/mm<sup>2</sup> (tensile)]

2. Determine : (i) location of neutral axis and (ii) maximum and minimum stresses, when a curved beam of trapezoidal section of bottom width 45 mm, top width 30 mm and height 60 mm is subjected to pure bending moment of + 1350 Nm. The bottom width is towards the centre of curvature. The radius of curvature is 75 mm and beam is curved in a plane parallel to depth. Also plot the variation of stresses across the section.

[Ans. (i)  $y_0 = -3.98$  mm (ii) 76.98 N/mm<sup>2</sup> (comp.), 50.65 N/mm<sup>2</sup> (tensile)]

3. Solve the problem 2, assuming the section to be circular of diameter 60 mm. The mean radius of curvature of the beam is 75 mm.

[Ans. (i)  $y_0 = -3.1$  mm (ii) 91.95 N/mm<sup>2</sup> (comp.) and 48.64 N/mm<sup>2</sup> (tensile)]

4. A central horizontal section of a hook is symmetrical trapezium 90 mm deep. The inner width being 90 mm and outer being 45 mm. The hook carries a load of 67.5 kN, the load line passes at a distance of 40 mm from the inside edge of the section. The centre of curvature is in the load line. Calculate the extreme intensities of stress. Also plot the stress distribution across the section.

[Ans. ( $\sigma_c$ )<sub>0</sub> = 53.15 N/mm<sup>2</sup> (comp) and ( $\sigma_t$ )<sub>i</sub> = 106.5 N/mm<sup>2</sup> (tensile)]

5. A central horizontal section of a hook is a symmetrical trapezium of inner width = 67.5 mm and of outer width = 22.5 mm. The depth of the section is 90 mm. The hook carries a load of 37.5 kN. The load line passes through the centre of curvature. The radius of the hook is 52.5 mm. Determine the maximum compressive and tensile stresses in the section of the hook.

[Ans. (i) 83.70 MN/m<sup>2</sup> (tensile) and (ii) 43.2 MN/m<sup>2</sup> (comp)]

6. A central horizontal section of a hook is a trapezium with inner width = 80 mm, outer width = 50 mm and depth 150 mm. The centre of curvature of the section is at a distance of 120 mm from the inner fibre and the load line is 100 mm from the inner fibre. What maximum load, the hook will carry if maximum stress is not to exceed 120 MN/m<sup>2</sup>. [Ans. 122.5 kN]

7. A central horizontal section of a hook is an  $I$ -section with inner width = 45 mm, middle width = 15 mm, outer width = 30 mm and inner thickness = 22.5 mm, middle thickness = 30 mm and outer thickness = 15 mm (i.e.,  $b_1 = 45$  mm,  $b_2 = 15$  mm,  $b_3 = 30$  mm,  $t_1 = 22.5$  mm,  $t_2 = 30$  mm and  $t_3 = 15$  mm). The load line passes through the centre of curvature and is at a distance of 30 mm from the inside edge of the section. The hook carries a load  $P$ . Determine the magnitude of  $P$  if the maximum stress in the hook is not to exceed 120 N/mm<sup>2</sup>. What will be the maximum compressive stress in the hook for that value of the load.

[Ans.  $P = 38.92$  kN,  $\sigma_c = 64.25$  N/mm<sup>2</sup> (comp)]

8. Determine the maximum tensile and compressive stresses produced in a closed ring when the ring is subjected to a pull of 11.25 kN, the line of action of which passes through the centre of the ring. The mean radius of curvature of the closed ring is 90 mm. The ring is circular in cross-section with diameter equal to 30 mm.

[Ans. (i) 20.35 N/mm<sup>2</sup> (comp.) and 13.6 N/mm<sup>2</sup> (tensile)]

9. A pull of 75 kN is applied at the ends of a simple link which consists of semi-circular ends of mean radius of curvature 60 mm and middle straight portion of length 60 mm. The link is circular in cross-section with radius = 30 mm. Determine the stresses in the link.

[Ans. (i) At  $\theta = 0$ , 93.65 N/mm<sup>2</sup> (comp) and 40.75 N/mm<sup>2</sup> (tensile)

(ii) At  $\theta = 90^\circ$ , 45.56 N/mm<sup>2</sup> (tensile) and 5.6 N/mm<sup>2</sup> (compressive)

(iii) Straight portion, 31.95 N/mm<sup>2</sup> (tensile) and 12 N/mm<sup>2</sup> (compressive)]

10. Find : (i) the position of neutral axis and (ii) greatest bending stresses, when a curved bar of rectangular section 30 mm wide by 37.5 mm deep initially unstressed is subjected to bending moment of 281.25 Nm which tends to straighten the bar. The mean radius of curvature is 75 mm.

[Hint.  $b = 30$  mm ;  $d = 37.5$  mm ;  $M = -281.25$  Nm =  $-281.25 \times 10^3$  Nmm (the bending moment  $M$  is -ve as it decreases the curvature of the bar or tends to straighten the bar) ;  $R = 75$  mm

$$A = b \times d = 30 \times 37.5 = 1125 \text{ mm}^2$$

$$\begin{aligned} h^2 &= \frac{R^3}{d} \left[ \log_e \left( \frac{2R+d}{2R-d} \right) \right] - R^2 \\ &= \frac{75^3}{37.5} \left[ \log_e \left( \frac{2 \times 75 + 37.5}{2 \times 75 - 37.5} \right) \right] - 75^2 \\ &= 11250[0.5108] - 5625 \\ &= 5746.78 - 5625 = 121.8 \text{ mm}^2 \end{aligned}$$

$$(i) y_0 = \frac{-Rh^2}{(R^2 + h^2)} = \frac{-75 \times 121.8}{(75^2 + 121.8)} = \frac{-75 \times 121.8}{5625 + 121.8} = -1.59 \text{ mm}$$

$$\begin{aligned} (ii) \sigma_b &= \frac{M}{A \times R} \left[ 1 + \frac{R^2}{h^2} \left( \frac{y}{R+y} \right) \right] \\ &= \frac{-281.25 \times 10^3}{1125 \times 75} \left[ 1 + \frac{75^2}{121.8} \left( \frac{y}{75+y} \right) \right] \\ &= -3.33 \left[ 1 + 46.182 \left( \frac{y}{75+y} \right) \right] \end{aligned}$$

$$\text{At } y = \frac{d}{2} = \frac{37.5}{2} = 18.75 \text{ mm, we get}$$

$$(\sigma_b)_0 = -3.33 \left[ 1 + 46.182 \times \frac{18.75}{(75 + 18.75)} \right] = -34.03 \text{ N/mm}^2 \text{ [compressive]}$$

$$\text{At } y = -\frac{d}{2} = -18.75 \text{ mm,}$$

$$(\sigma_b)_1 = -3.33 \left[ 1 + 46.182 \times \frac{(-18.75)}{75 - 18.75} \right] = +47.93 \text{ N/mm}^2 \text{ (tensile)}$$

# 24

## Theories of Failure

### 24.1. INTRODUCTION

When some external load\* is applied on a body, the stresses and strains are produced in the body. The stresses are directly proportional to the strains within the elastic limit. This means when the load is removed, the body will return to its original shape. There is no permanent deformation in the body.

However, if the stress produced in the body due to the application of the load, is beyond the elastic limit, the permanent deformations occur in the body. This means if the load is removed, the body will not retain its original shape. There are some permanent deformations in the body. Whenever permanent deformations occur in the body, the body is said to have "failed". This should be clear that failure does not mean rupture of the body.

Let us consider the failure (or permanent deformation) of a bar in a simple tensile test. The tensile stress is directly proportional to the tensile strain upto elastic limit. This means that there is a definite value of tensile stress upto elastic limit. Beyond the elastic limit if the tensile stress increases, the failure of the bar will take place. At this stage, why the failure takes place? It may be due to the increase of tensile stress or due to other quantities such as shear stress and strain energy also attain definite values, and anyone of these may be deciding factor of the failure of the bar. Certain theories have advanced to explain the cause of failure. According to the important theories, the failure takes place when a certain limiting value is reached by one of following :

1. The maximum principal stress,
2. The maximum principal strain,
3. The maximum shear stress,
4. The maximum strain energy,
5. The maximum shear strain energy.

In all the above cases,

$\sigma_1, \sigma_2, \sigma_3$  = principal stresses in any complex system

$\sigma^*$  = tensile or compressive stress at the elastic limit.

### 24.2. MAXIMUM PRINCIPAL STRESS THEORY

According to this theory, the failure of a material will occur when the maximum principal tensile stress ( $\sigma_1$ ) in the complex system reaches the value of the maximum stress at the elastic limit in simple tension or the minimum principal stress (*i.e.*, the maximum principal

\*The loading on the body is assumed gradual or static.

compressive stress) reaches the value of the maximum stress at the elastic limit in simple compression.

Let in a complex three dimensional stress system,

$\sigma_1, \sigma_2$  and  $\sigma_3$  = principal stresses at a point in three perpendicular directions. The stresses  $\sigma_1$  and  $\sigma_2$  are tensile and  $\sigma_3$  is compressive. Also  $\sigma_1$  is more than  $\sigma_2$ .

$\sigma_t^*$  = tensile stress at elastic limit in simple tension.

$\sigma_c^*$  = compressive stress at elastic limit in simple compression.

Then according to this theory, the failure will take place if

$$\sigma_1 \geq \sigma_t^* \text{ in simple tension} \quad \dots[24.1]$$

$$\text{or } |\sigma_3| \geq \sigma_c^* \text{ in simple compression} \quad \dots[24.1(A)]$$

where  $|\sigma_3|$  represents the absolute value of  $\sigma_3$ .

This is the simplest and oldest theory of failure and is known as *Rankine's theory*. If the maximum principal stress ( $\sigma_1$ ) is the design criterion, then maximum principal stress must not exceed the permissible stress ( $\sigma_t$ ) for the given material.

$$\text{Hence } \sigma_1 = \sigma_t \quad \dots[24.1(B)]$$

where  $\sigma_t$  = permissible stress and is given by

$$\sigma_t = \sigma_t^*/\text{safety factor} \quad \dots[24.1(C)]$$

### 24.3. MAXIMUM PRINCIPAL STRAIN THEORY

This theory is due to Saint Venant. According to this theory, the failure will occur in a material when the maximum principal strain reaches the strain due to yield stress in simple tension or when the minimum principal strain (i.e., maximum compressive strain) reaches the strain due to yield stress in simple compression. Yield stress is the maximum stress at elastic limit. Consider a three dimensional stress system.

Principal strain in the direction of principal stress  $\sigma_1$  is,

$$e_1 = \frac{\sigma_1}{E} - \frac{\mu \sigma_2}{E} - \frac{\mu \sigma_3}{E}$$

$$= \frac{1}{E} [\sigma_1 - \mu(\sigma_2 + \sigma_3)]$$

Principal strain in the direction of principal stress  $\sigma_3$  is

$$e_3 = \frac{1}{E} [\sigma_3 - \mu(\sigma_1 + \sigma_2)]$$

$$\text{Strain due to yield stress in simple tension} = \frac{1}{E} \times \text{yield stress in tension}$$

$$= \frac{1}{E} \times \sigma_t^*$$

$$\text{and strain due to yield stress in simple compression} = \frac{1}{E} \times \sigma_c^*$$

where yield stress is the maximum stress at elastic limit.

According to this theory, the failure of the material will take place when

$$e_1 \geq \frac{\sigma_t^*}{E}$$

$$\text{or } |e_3| \geq \frac{\sigma_c^*}{E}$$

Substituting the values of  $e_1$  and  $e_3$ , we get the conditions of failure as :

$$(i) \quad \frac{1}{E} [\sigma_1 - \mu(\sigma_2 + \sigma_3)] \geq \frac{1}{E} \times \sigma_t^*$$

$$\text{or } \sigma_1 - \mu(\sigma_2 + \sigma_3) \geq \sigma_t^* \quad \dots[24.2]$$

$$(ii) \quad \left| \frac{1}{E} [\sigma_3 - \mu(\sigma_1 + \sigma_2)] \right| \geq \frac{1}{E} \times \sigma_c^*$$

$$\text{or } |[\sigma_3 - \mu(\sigma_1 + \sigma_2)]| \geq \sigma_c^* \quad \dots[24.2(A)]$$

For actual design (i.e., where some quantity is to be calculated), instead of  $\sigma_t^*$  or  $\sigma_c^*$ , the permissible stress ( $\sigma_t$  or  $\sigma_c$ ) in simple tension or compression should be used where

$$\sigma_t = \frac{\sigma_t^*}{\text{Safety factor}} \quad \dots[24.2(B)]$$

$$\text{and } \sigma_c = \frac{\sigma_c^*}{\text{Safety factor}} \quad \dots[24.2(C)]$$

Hence for design purpose, the equations (24.2) and [24.2(A)] becomes as

$$\sigma_1 - \mu(\sigma_2 + \sigma_3) = \sigma_t \quad \dots[24.2(D)]$$

$$\text{and } |[\sigma_3 - \mu(\sigma_1 + \sigma_2)]| = \sigma_c \quad \dots[24.2(E)]$$

The equations [24.2(D)] and [24.2(E)] should be used for design purposes (where some calculations are done) only. They should not be used for determining the failure of the material.

**Problem 24.1.** The principal stresses at a point in an elastic material are 100 N/mm<sup>2</sup> (tensile), 80 N/mm<sup>2</sup> (tensile) and 50 N/mm<sup>2</sup> (compressive). If the stress at the elastic limit in simple tension is 200 N/mm<sup>2</sup>, determine whether the failure of material will occur according to maximum principal stress theory. If not, then determine the factor of safety.

**Sol.** Given :

The three principal stresses are :

$$\sigma_1 = 100 \text{ N/mm}^2 \text{ (tensile)}$$

$$\sigma_2 = 80 \text{ N/mm}^2 \text{ (tensile)}$$

$$\sigma_3 = 50 \text{ N/mm}^2 \text{ (compressive)} = -50 \text{ N/mm}^2$$

Stress at elastic limit in simple tension,

$$\sigma_t^* = 200 \text{ N/mm}^2.$$

(i) To determine whether failure of material will occur or not

From the three given stresses, the maximum principal tensile stress is  $\sigma_1 = 100 \text{ N/mm}^2$ . And the stress at elastic limit in simple tension is  $\sigma_t^* = 200 \text{ N/mm}^2$ . As  $\sigma_1$  is less than  $\sigma_t^*$ , the failure will not occur according to maximum principal stress theory. **Ans.**

(ii) Factor of safety

Using equation [24.1(B)], we get

$$\sigma_1 = \sigma_t \quad \therefore \sigma_t = 100 \text{ N/mm}^2$$

From equation [24.1(C)],

$$\sigma_t = \frac{\sigma_t^*}{\text{Factor of safety}} \quad \therefore \text{Factor of safety} = \frac{\sigma_t^*}{\sigma_t}$$

$$= \frac{200}{100} = 2.0. \quad \text{Ans.}$$

**Problem 24.2.** The principal stresses at a point in an elastic material are 200 N/mm<sup>2</sup> (tensile), 100 N/mm<sup>2</sup> (tensile) and 50 N/mm<sup>2</sup> (compressive). If the stress at the elastic limit in

simple tension is  $200 \text{ N/mm}^2$ , determine whether the failure of the material will occur according to maximum principal strain theory. Take Poisson's ratio = 0.3.

**Sol.** Given :

The principal stresses are :

$$\sigma_1 = 200 \text{ N/mm}^2 \text{ (tensile)}$$

$$\sigma_2 = 100 \text{ N/mm}^2 \text{ (tensile)}$$

$$\sigma_3 = 50 \text{ N/mm}^2 \text{ (compressive)} = -50 \text{ N/mm}^2$$

Stress at elastic limit in simple tension,

$$\sigma_t^* = 200 \text{ N/mm}^2$$

Poisson's ratio,  $\mu = 0.3$

To determine whether failure of material will occur or not according to maximum principal strain theory.

Out of three principal stresses, the maximum principal tensile stress is  $\sigma_1$ . Hence the maximum principal strain will be in the direction of  $\sigma_1$ . Let this strain is  $e_1$ . Hence maximum principal strain in the direction of  $\sigma_1$  will be,

$$\begin{aligned} e_1 &= \frac{1}{E} [\sigma_1 - \mu(\sigma_2 + \sigma_3)] \\ &= \frac{1}{E} [200 - 0.3(100 + (-50))] \quad [\because \sigma_3 = -50] \\ &= \frac{1}{E} [200 - 30 + 15] = \frac{185}{E} \quad \dots(i) \end{aligned}$$

Strain due to stress at elastic limit in simple tension,

$$e_t^* = \frac{\sigma_t^*}{E} = \frac{200}{E} \quad \dots(ii)$$

According to maximum principal strain theory, the failure of a material occurs if the maximum principal strain ( $e_1$ ) reaches the strain due to stress at elastic limit in simple tension. Here  $e_1 < e_t^*$ , hence failure will not occur. **Ans.**

**Problem 24.3.** Determine the diameter of a bolt which is subjected to an axial pull of 9 kN together with a transverse shear force of 4.5 kN using : (i) Maximum principal stress theory, and (ii) Maximum principal strain theory.

Given the elastic limit in tension =  $225 \text{ N/mm}^2$ , factor of safety = 3 and Poisson's ratio = 0.3.

**Sol.** Given :

$$\text{Axial pull, } P = 9 \text{ kN} = 9 \times 1000 \text{ N} = 9000 \text{ N}$$

$$\text{Transverse shear force, } F = 4.5 \text{ kN} = 4500 \text{ N}$$

$$\text{Elastic limit in tension, } \sigma_t^* = 225 \text{ N/mm}^2$$

$$\text{Factor of safety} = 3, \text{ Poisson's ratio, } \mu = 0.3$$

The permissible stress in tension is given by equation [24.2(B)] as

$$\sigma_t = \frac{\sigma_t^*}{\text{Safety factor}} = \frac{225}{3} = 75 \text{ N/mm}^2$$

The axial pull will produce tensile stress whereas transverse shear force will produce shear stress in the bolt. Let us calculate these stresses.

Let  $d$  = diameter of bolt in mm.

$$\text{Now tensile stress, } \sigma = \frac{P}{\text{Area of cross-section}} = \frac{P}{\frac{\pi d^2}{4}} = \frac{4P}{\pi d^2}$$

$$= \frac{4 \times 9000}{\pi d^2} = \frac{11459}{d^2} \text{ N/mm}^2$$

$$\text{and shear stress, } \tau = \frac{F}{\frac{\pi d^2}{4}} = \frac{4F}{\pi d^2} = \frac{4 \times 4500}{\pi d^2} = \frac{5729.5}{d^2} \text{ N/mm}^2$$

Now let us calculate the maximum and minimum principal stresses  $\sigma_1$  and  $\sigma_2$ .

The principal stresses (maximum and minimum) in the bolt are given by

$$\sigma_1 \text{ and } \sigma_2 = \frac{\sigma}{2} \pm \sqrt{\left(\frac{\sigma}{2}\right)^2 + \tau^2} \quad [\text{Refer to equation (3.16). Here } \sigma_x = \sigma, \sigma_y = 0]$$

$$= \frac{11459}{2 \times d^2} \pm \sqrt{\left(\frac{11459}{2 \times d^2}\right)^2 + \left(\frac{5729.5}{d^2}\right)^2}$$

$$= \frac{5729.5}{d^2} \pm \sqrt{\left(\frac{5729.5}{d^2}\right)^2 + \left(\frac{5729.5}{d^2}\right)^2}$$

$$= \frac{5729.5}{d^2} \pm \frac{5729.5}{d^2} \sqrt{(1+1)}$$

$$= \frac{5729.5}{d^2} \pm \frac{8103}{d^2}$$

$$\therefore \sigma_1 = \frac{5729.5}{d^2} + \frac{8103}{d^2} = \frac{13832.5}{d^2} \text{ N/mm}^2$$

$$\text{and } \sigma_2 = \frac{5729.5}{d^2} - \frac{8103}{d^2} = \frac{-2373.5}{d^2} \text{ N/mm}^2$$

Hence the principal stresses in the bolt are :

$$\sigma_1, \sigma_2 \text{ and } 0 \text{ or } \frac{13832.5}{d^2}, \frac{-2373.5}{d^2} \text{ and } 0.$$

(i) Diameter of bolt according to maximum principal stress theory

Here diameter of the bolt is to be calculated. This becomes the case of design. For the purpose of design, according to maximum principal stress theory, the maximum principal stress should not exceed the permissible stress ( $\sigma_t$ ) in tension. Here the maximum principal stress is  $\sigma_1$ .

Hence using equation [24.1(B)], we get

$$\frac{13832.5}{d^2} = 75 \quad (\because \sigma_t = 75 \text{ N/mm}^2)$$

or

$$d^2 = \frac{13832.5}{75}$$

or

$$d = \sqrt{\frac{13832.5}{75}} = 13.58 \approx 13.6 \text{ mm. Ans.}$$



(ii) Diameter of bolt according to maximum principal strain theory

The three principal stresses are :

$$\sigma_1 = \frac{13832.5}{d^2} \text{ N/mm}^2$$

$$\sigma_2 = \frac{-2373.5}{d^2} \text{ N/mm}^2 \text{ and } \sigma_3 = 0$$

Here maximum principal stress is  $\sigma_1$ . Hence maximum strain will be in the direction of

$\sigma_1$ .

$$\begin{aligned} \therefore \text{Maximum strain} &= \frac{\sigma_1}{E} - \frac{\mu}{E}(\sigma_2 + \sigma_3) \\ &= \frac{1}{E}[\sigma_1 - \mu(\sigma_2 + \sigma_3)] \\ &= \frac{1}{E}\left[\frac{13832.5}{d^2} - 0.3\left(\frac{-2373.5}{d^2} + 0\right)\right] \\ &= \frac{1}{E}\left[\frac{13832.5}{d^2} + \frac{712.05}{d^2}\right] \\ &= \frac{1}{E} \times \frac{14544.55}{d^2} \quad \dots(i) \end{aligned}$$

Maximum strain due to permissible stress in tension =  $\frac{1}{E} \times \sigma_t$

$$= \frac{1}{E} \times 75 \quad (\because \sigma_t = 75) \dots(ii)$$

For design purpose, (as here diameter is to be calculated), the maximum strain should be equal to the strain due to permissible stress in tension.

Hence equating the two values given by equations (i) and (ii), we get

$$\frac{1}{E} \times \frac{14544.55}{d^2} = \frac{1}{E} \times 75$$

$$\text{or } d = \sqrt{\frac{14544.55}{75}} = 13.92 \text{ mm. Ans.}$$

#### 24.4. MAXIMUM SHEAR STRESS THEORY

This theory is due to Guest and Tresca and therefore known as Guest's theory. According to this theory, the failure of a material will occur when the maximum shear stress in a material reaches the value of maximum shear stress in simple tension at the elastic limit. The maximum shear stress in the material is equal to half the difference between maximum and minimum principal stress.

If  $\sigma_1$ ,  $\sigma_2$  and  $\sigma_3$  are principal stresses at a point in a material for which  $\sigma_t^*$  is the principal stress in simple tension at elastic limit, then

Max. shear stress in the material = Half of difference of maximum and minimum principal stresses

$$= \frac{1}{2}[\sigma_1 - \sigma_3]$$

In case of simple tension, at the elastic limit the principal stresses are  $\sigma_t^*$ , 0, 0

[In simple tension, the stress is existing in one direction only]

$$\begin{aligned} \therefore \text{Max. shear stress in simple tension at elastic limit} \\ &= \text{Half of difference of maximum and minimum principal stresses} \\ &= \frac{1}{2}[\sigma_t^* - 0] = \frac{1}{2}\sigma_t^* \end{aligned}$$

\(\therefore\) For the failure of material,

$$\frac{1}{2}[\sigma_1 - \sigma_3] \geq \frac{1}{2}\sigma_t^* \text{ or } (\sigma_1 - \sigma_3) \geq \sigma_t^* \quad \dots(24.3)$$

For actual design (i.e., when some quantity is to be calculated) instead of  $\sigma_t^*$ , the allowable stress ( $\sigma_t$ ) in simple tension should be considered

$$\text{where } \sigma_t = \frac{\sigma_t^*}{\text{Safety factor}}$$

Hence for design, the following equation should be used

$$(\sigma_1 - \sigma_3) = \sigma_t \quad \dots[24.3(A)]$$

The equation [24.3(A)] is to be used for design purpose only (i.e., when some quantity is to be calculated). It should not be used for determining the failure of the material due to maximum shear stress theory.

**Problem 24.4.** For the data given in Problem 24.2, determine whether failure of material will occur or not according to maximum shear stress theory.

**Sol.** Given : Data from Problem 24.2 :

$$\sigma_1 = 200 \text{ N/mm}^2 \text{ (tensile)}$$

$$\sigma_2 = 100 \text{ N/mm}^2 \text{ (tensile)}$$

$$\sigma_3 = 50 \text{ N/mm}^2 \text{ (compressive)} = -50 \text{ N/mm}^2$$

$$\sigma_t^* = 200 \text{ N/mm}^2.$$

Now max. shear stress developed in the material

= Half of difference of maximum and minimum principal stresses

$$= \frac{1}{2}[\sigma_1 - \sigma_3] = \frac{1}{2}[200 - (-50)]$$

$$= \frac{250}{2} = 125 \text{ N/mm}^2 \text{ [Here } \sigma_1 \text{ is maximum and } \sigma_3 \text{ is minimum]}$$

Max. shear stress at elastic limit in simple tension

$$= \frac{1}{2} \times \sigma_t^*$$

$$= \frac{1}{2} \times 200 = 100 \text{ N/mm}^2.$$

As maximum shear stress developed in the material is 125 N/mm<sup>2</sup> whereas maximum shear stress at the elastic limit in simple tension is 100 N/mm<sup>2</sup>, hence failure will occur. **Ans.**

**Problem 24.5.** At a section of a mild steel shaft, the maximum torque is 8437.5 Nm and maximum bending moment is 5062.5 Nm. The diameter of shaft is 90 mm and the stress at the elastic limit in simple tension for the material of the shaft is 220 N/mm<sup>2</sup>. Determine whether the failure of the material will occur or not according to maximum shear stress theory. If not, then find the factor of safety.

**Sol.** Given :

$$\text{Maximum torque, } T = 8437.5 \text{ Nm}$$

$$\text{Maximum bending moment, } M = 5062.5 \text{ Nm}$$

Stress at elastic limit in simple tension,

$$\sigma_t^* = 220 \text{ N/mm}^2 = 220 \times 10^6 \text{ N/m}^2 = 220 \text{ MN/m}^2$$

Dia. of shaft,  $d = 90 \text{ mm} = 0.09 \text{ m}$ .

At any section, the torque will produce shear stress whereas the bending moment will produce bending stress. These stresses will be maximum on the surface of the shaft. Let us find these stresses first.

We know that  $T = \frac{\pi}{16} \times d^3 \times \tau$

$$\therefore \tau = \frac{16 \times T}{\pi d^3} = \frac{16 \times 8437.5}{\pi \times (0.09)^3} \text{ N/m}^2 = 58.946 \times 10^6 \text{ N/m}^2 = 58.946 \text{ MN/m}^2$$

Also we know that  $\frac{M}{I} = \frac{\sigma_b}{y}$

or  $\sigma_b = \frac{M \times y}{I}$  where on the surface  $y = \frac{d}{2}$

$$= \frac{M \times d}{I \times 2} = \frac{M \times d}{\left(\frac{\pi}{64} d^4\right) \times 2}$$

$$= \frac{32 M}{\pi d^3} = \frac{32 \times 5062.5}{\pi \times (0.09)^3}$$

$$= 70.735 \times 10^6 \text{ N/m}^2 = 70.735 \text{ MN/m}^2$$

On the surface of the shaft, at any point the shear stress is  $58.946 \text{ MN/m}^2$  and bending stress is  $70.735 \text{ MN/m}^2$ . The principal stresses at this point is given by,

$$\sigma_1 \text{ and } \sigma_2 = \frac{\sigma_b}{2} \pm \sqrt{\left(\frac{\sigma_b}{2}\right)^2 + \tau^2}$$

[See equation (3.16). Here  $\sigma_x = \sigma_b$  and  $\sigma_y = 0$ ]

$$= \frac{70.735}{2} \pm \sqrt{\left(\frac{70.735}{2}\right)^2 + (58.946)^2}$$

$$= 35.365 \pm 68.75$$

$$= 104.115 \text{ MN/m}^2 \text{ and } -33.385 \text{ MN/m}^2$$

$$\therefore \sigma_1 = 104.115 \text{ MN/m}^2 \text{ and } \sigma_2 = -33.385 \text{ MN/m}^2$$

Hence the principal stresses at a point on the surface of the shaft are :  $104.115 \text{ MN/m}^2$ ,  $-33.385 \text{ MN/m}^2$  and  $0$ .

Now apply the maximum shear stress theory.

Maximum shear stress due to principal stresses

= Half of difference between maximum and minimum principal stresses

$$= \frac{1}{2} [104.115 - (-33.385)]$$

$$= \frac{1}{2} [104.115 + 33.385]$$

$$= 68.75 \text{ MN/m}^2 \quad \dots(i)$$

In simple tension the stress system is uniaxial hence the principal stresses are  $\sigma_t^*$ ,  $0$ ,  $0$

$\therefore$  Maximum shear stress in simple tension

$$= \frac{1}{2} [\sigma_t^* - 0] = \frac{\sigma_t^*}{2}$$

$$= \frac{220}{2} = 110 \text{ MN/m}^2$$

As the maximum shear stress due to principal stresses is less than the maximum shear stress in simple tension at the elastic limit, the failure of the material will not occur.

**Factor of Safety**

Let  $\sigma_t$  = Allowable tensile stress in simple tension. Then principal stresses in simple tension will be  $\sigma_t$ ,  $0$ ,  $0$ .

And the maximum allowable shear stress in simple tension will be

$$= \frac{1}{2} [\sigma_t - 0] = \frac{\sigma_t}{2} \quad \dots(ii)$$

Equating the two equations (i) and (ii), we get

$$68.75 = \frac{\sigma_t}{2}$$

or  $\sigma_t = 68.75 \times 2 = 137.5 \text{ MN/m}^2$

$$\text{Factor of safety} = \frac{\sigma_t^*}{\sigma_t} = \frac{220}{137.5} = 1.6 \quad \text{Ans.}$$

**Problem 24.6.** According to the theory of maximum shear stress, determine the diameter of a bolt which is subjected to an axial pull of  $9 \text{ kN}$  together with a transverse shear force of  $4.5 \text{ kN}$ . Elastic limit in tension is  $225 \text{ N/mm}^2$ , factor of safety =  $3$  and Poisson's ratio =  $0.3$ .

**Sol.** Given :

Axial pull,  $P = 9 \text{ kN} = 9000 \text{ N}$

Shear force,  $F = 4.5 \text{ kN} = 4.5 \times 1000 = 4500 \text{ N}$

Elastic limit in tension,  $\sigma_t^* = 225 \text{ N/mm}^2$

Factor of safety =  $3$

$$\therefore \text{Permissible simple stress in tension, } \sigma_t = \frac{\sigma_t^*}{3} = \frac{225}{3} = 75 \text{ N/mm}^2$$

Poisson's ratio,  $\mu = 0.3$

The axial pull will produce tensile stress whereas the transverse shear force will produce shear stress in the bolt.

$\therefore$  Let  $d$  = diameter of the bolt in mm.

Tensile stress due to axial pull,

$$\sigma = \frac{P}{\text{Area of cross-section}}$$

$$= \frac{P}{\frac{\pi}{4} d^2} = \frac{9000 \times 4}{\pi d^2} \text{ N/mm}^2$$

$$= \frac{11459}{d^2} \text{ N/mm}^2$$

Shear stress due to transverse shear force,

$$\tau = \frac{F}{\frac{\pi}{4}d^2} = \frac{4500 \times 4}{\pi d^2} = \frac{5729.5}{d^2} \text{ N/mm}^2$$

The maximum and minimum principal stresses in the bolt are given by

$$\sigma_1 \text{ and } \sigma_2 = \frac{1}{2} \times \sigma \pm \sqrt{\left(\frac{\sigma}{2}\right)^2 + \tau^2}$$

[Refer to equation (3.16). Here  $\sigma_x = \sigma$ ,  $\sigma_y = 0$ ]

$$\sigma_1 = \frac{\sigma}{2} + \sqrt{\left(\frac{\sigma}{2}\right)^2 + \tau^2} \quad \text{and} \quad \sigma_2 = \frac{\sigma}{2} - \sqrt{\left(\frac{\sigma}{2}\right)^2 + \tau^2}$$

or

Hence the principal stresses in the bolt are :

$$\frac{\sigma}{2} + \sqrt{\left(\frac{\sigma}{2}\right)^2 + \tau^2}, \frac{\sigma}{2} - \sqrt{\left(\frac{\sigma}{2}\right)^2 + \tau^2} \text{ and } 0$$

Now apply the theory of maximum shear stress.

Maximum shear stress due to principal stresses

$$\begin{aligned} &= \frac{1}{2} \left[ \left( \frac{\sigma}{2} + \sqrt{\left(\frac{\sigma}{2}\right)^2 + \tau^2} \right) - \left( \frac{\sigma}{2} - \sqrt{\left(\frac{\sigma}{2}\right)^2 + \tau^2} \right) \right] \\ &= \frac{1}{2} \left[ 2 \times \sqrt{\left(\frac{\sigma}{2}\right)^2 + \tau^2} \right] = \sqrt{\left(\frac{\sigma}{2}\right)^2 + \tau^2} \\ &= \sqrt{\left(\frac{11459}{2 \times d^2}\right)^2 + \left(\frac{5729.5}{d^2}\right)^2} \quad \left[ \because \sigma = \frac{11459}{d^2} \text{ and } \tau = \frac{5729.5}{d^2} \right] \\ &= \frac{8103}{d^2} \quad \dots(i) \end{aligned}$$

Max. shear stress in simple tension

$$= \frac{1}{2} [\sigma_t - 0] = \frac{\sigma_t}{2} = \frac{75}{2} = 37.5 \text{ N/mm}^2 \quad \dots(ii)$$

Equating the two maximum shear stresses given by equations (i) and (ii), we get

$$\frac{8103}{d^2} = 37.5 \quad \text{or} \quad d = \sqrt{\frac{8103}{37.5}} = 14.70 \text{ mm. Ans.}$$

## 24.5. MAXIMUM STRAIN ENERGY THEORY

This theory is due to Haigh and is known as Haigh's Theory. According to this theory, the failure of a material occurs when the total strain energy per unit volume in the material reaches the strain energy per unit volume of the material at the elastic limit in simple tension.

In chapter 4, we have stated that the strain energy in a body is equal to work done by

the load ( $P$ ) in straining the material and it is equal to  $\frac{1}{2} \times P \times \delta L$

( $\because$  Load is gradually increased from 0 to  $P$ )

$\therefore U =$  Strain energy

$$= \frac{1}{2} \times P \times \delta L$$

$$= \frac{1}{2} \times (\sigma \times A) \times (e) \times L$$

$$\left[ \because \sigma = \frac{P}{A} \quad \therefore P = \sigma \times A \right. \\ \left. \text{and } e = \frac{\delta L}{L} \quad \therefore \delta L = e \times L \right]$$

$$= \frac{1}{2} \times \sigma \times e \times A \times L$$

$$= \frac{1}{2} \times \text{stress} \times \text{strain} \times \text{volume} \quad (\because A \times L = \text{volume})$$

$\therefore$  Strain energy per unit volume

$$= \frac{1}{2} \times \text{stress} \times \text{strain}$$

$$= \frac{1}{2} \times \sigma \times e \quad \dots(24.4)$$

For a three dimensional stress system, the principal stresses acting at a point are  $\sigma_1$ ,  $\sigma_2$  and  $\sigma_3$ . The corresponding strains are  $e_1$ ,  $e_2$  and  $e_3$ , where  $e_1 =$  principal strain in the direction of  $\sigma_1$

$$\text{Now, } e_2 = \frac{\sigma_1}{E} - \frac{\mu}{E} (\sigma_2 + \sigma_3)$$

$$\text{Similarly, } e_2 = \frac{\sigma_2}{E} - \frac{\mu}{E} (\sigma_3 + \sigma_1)$$

$$\text{and } e_3 = \frac{\sigma_3}{E} - \frac{\mu}{E} (\sigma_1 + \sigma_2)$$

$\therefore$  Total strain energy per unit volume in three dimensional system,

$$\begin{aligned} U &= \frac{1}{2} \times \sigma_1 \times e_1 + \frac{1}{2} \times \sigma_2 \times e_2 + \frac{1}{2} \times \sigma_3 \times e_3 \\ &= \frac{1}{2} \sigma_1 \times \left[ \frac{\sigma_1}{E} - \frac{\mu}{E} (\sigma_2 + \sigma_3) \right] + \frac{1}{2} \sigma_2 \times \left[ \frac{\sigma_2}{E} - \frac{\mu}{E} (\sigma_3 + \sigma_1) \right] \\ &\quad + \frac{1}{2} \sigma_3 \times \left[ \frac{\sigma_3}{E} - \frac{\mu}{E} (\sigma_1 + \sigma_2) \right] \\ &= \frac{1}{2E} [\sigma_1^2 + \sigma_2^2 + \sigma_3^2 - 2\mu(\sigma_1\sigma_2 + \sigma_2\sigma_3 + \sigma_3\sigma_1)] \quad \dots(24.5) \end{aligned}$$

The strain energy per unit volume corresponding to stress at elastic limit in simple tension

$$\begin{aligned} &= \frac{1}{2} \times \sigma_t^* \times e_t^* \quad \left[ \text{where } e_t^* = \text{strain due to } \sigma_t^* \right] \\ &= \frac{1}{2} \times \sigma_t^* \times \frac{\sigma_t^*}{E} \quad \left[ \because E = \frac{\sigma_t^*}{e_t^*} \text{ or } e_t^* = \frac{\sigma_t^*}{E} \right] \\ &= \frac{1}{2E} \times (\sigma_t^*)^2 \quad \dots(24.6) \end{aligned}$$

For the failure of the material

$$\frac{1}{2E} [\sigma_1^2 + \sigma_2^2 + \sigma_3^2 - 2\mu(\sigma_1\sigma_2 + \sigma_2\sigma_3 + \sigma_3\sigma_1)] \geq \frac{1}{2E} \times (\sigma_t^*)^2$$

or

$$[\sigma_1^2 + \sigma_2^2 + \sigma_3^2 - 2\mu(\sigma_1\sigma_2 + \sigma_2\sigma_3 + \sigma_3\sigma_1)] \geq (\sigma_t^*)^2 \quad \dots(24.7)$$

For a two-dimensional stress system,  $\sigma_3 = 0$ . Hence above equation becomes as

$$\sigma_1^2 + \sigma_2^2 - 2\mu(\sigma_1\sigma_2) \geq (\sigma_t^*)^2 \quad \dots(24.8)$$

For actual design (*i.e.*, when some quantity is to be calculated) in stead of  $\sigma_t^*$ , the allowable stress ( $\sigma_t$ ) in simple tension should be considered where

$$\sigma_t = \frac{\sigma_t^*}{\text{Factor of safety}}$$

Hence for design, the following equation should be used

$$\sigma_1^2 + \sigma_2^2 - 2\mu(\sigma_1 \times \sigma_2) = \sigma_t^2 \quad \dots(24.9)$$

The equation (24.9) is used for design purpose only. It is not used for determining the failure of material due to maximum strain energy theory.

**Problem 24.7.** For the data given in Problem 24.2, determine whether failure of material will occur or not according to maximum strain energy theory.

**Sol.** Data from Problem 24.2 are :

$$\begin{aligned} \sigma_1 &= 200 \text{ N/mm}^2 \text{ (tensile)} \\ \sigma_2 &= 100 \text{ N/mm}^2 \text{ (tensile)} \\ \sigma_3 &= 50 \text{ N/mm}^2 \text{ (compressive)} = -50 \text{ N/mm}^2 \\ \mu &= 0.3 \end{aligned}$$

Elastic limit in simple tension,  $\sigma_t^* = 200 \text{ N/mm}^2$

The total strain energy absorbed per unit volume in the material is given by equation (24.5).

$\therefore$  Total strain energy per unit volume in the material

$$\begin{aligned} &= \frac{1}{2E} [\sigma_1^2 + \sigma_2^2 + \sigma_3^2 - 2\mu(\sigma_1\sigma_2 + \sigma_2\sigma_3 + \sigma_3\sigma_1)] \\ &= \frac{1}{2E} [200^2 + 100^2 + (-50)^2 - 2 \times 0.3 \{200 \times 100 \\ &\quad + 100 \times (-50) + (-50) \times 200\}] \\ &= \frac{1}{2E} [40000 + 10000 + 2500 - 0.6(20000 - 5000 - 10000)] \\ &= \frac{1}{2E} [52500 - 0.6 \times 5000] = \frac{1}{2E} [49500] \quad \dots(i) \end{aligned}$$

Strain energy per unit volume corresponding to stress at elastic limit in simple tension is given by equation (24.6).

$\therefore$  Strain energy per unit volume at elastic limit in simple tension

$$\begin{aligned} &= \frac{1}{2E} \times \sigma_t^{*2} \\ &= \frac{1}{2E} \times 200^2 \quad (\because \sigma_t^* = 200) \\ &= \frac{40000}{2E} \quad \dots(ii) \end{aligned}$$

Now apply the theory of maximum strain energy.

If we compare equations (i) and (ii), we find the total strain energy per unit volume in the material is more than the strain energy per unit volume at elastic limit in simple tension. Hence failure will occur. **Ans.**

**Problem 24.8.** For the data given in Problem 24.6, determine the diameter of the bolt according to maximum strain energy theory.

**Sol.** Data from Problem 24.6 are :

$$P = 9 \text{ kN} = 9000 \text{ N}; \text{ Shear force, } F = 4500 \text{ N}; \sigma_t^* = 225 \text{ N/mm}^2; \text{ Safety factor} = 3; \mu = 0.3$$

$$\text{Now permissible simple stress in tension, } \sigma_t = \frac{\sigma_t^*}{\text{Safety factor}} = \frac{225}{3} = 75 \text{ N/mm}^2$$

The other values as calculated in Problem 24.6 are :

$$\sigma = \frac{11459}{d^2} \text{ N/mm}^2, \tau = \frac{5729.5}{d^2} \text{ N/mm}^2, \text{ where } d = \text{dia. of bolt}$$

The maximum and minimum principal stresses are :

$$\sigma_1 \text{ and } \sigma_2 = \frac{1}{2} \times \sigma \pm \sqrt{\left(\frac{\sigma}{2}\right)^2 + \tau^2} \quad \left[ \text{The value of } \sqrt{\left(\frac{\sigma}{2}\right)^2 + \tau^2} \text{ has been calculated as is equal to } \frac{8103}{d^2} \right]$$

$$= \frac{11459}{2d^2} \pm \frac{8103}{d^2}$$

$$= \frac{5729.5}{d^2} \pm \frac{8103}{d^2}$$

$$\therefore \sigma_1 = \frac{5729.5}{d^2} + \frac{8103}{d^2} = \frac{13832.5}{d^2} \text{ N/mm}^2$$

and

$$\sigma_2 = \frac{5729.5}{d^2} - \frac{8103}{d^2} = \frac{-2373.5}{d^2} \text{ N/mm}^2$$

Hence the principal stresses at the point are :  $\sigma_1$ ,  $\sigma_2$  and 0

$$\text{or } \frac{13832.5}{d^2}, \frac{-2373.5}{d^2}, 0$$

This is a case of two-dimensional stress system and diameter is to be calculated hence using equation (24.9) which is according to maximum strain energy theory, we get

$$\sigma_1^2 + \sigma_2^2 - 2\mu(\sigma_1 \times \sigma_2) = \sigma_t^2$$

$$\text{or } \left[ \frac{13832.5}{d^2} \right]^2 + \left[ \frac{-2373.5}{d^2} \right]^2 - 2 \times 0.3 \left[ \frac{13832.5}{d^2} \times \frac{(-2373.5)}{d^2} \right] = 75^2 \quad (\because \sigma_t = 75)$$

$$\frac{19134 \times 10^4}{d^4} + \frac{563.35 \times 10^4}{d^4} + \frac{1969.9 \times 10^4}{d^4} = 5625$$

$$\text{or } \frac{21667.25 \times 10^4}{d^4} = 5625$$

$$\text{or } d = \left( \frac{21667.25 \times 10^4}{5625} \right)^{1/4} = 10 \times (3.852)^{1/4}$$

$$= 10 \times 1.401 = 14.01 \text{ mm. Ans.}$$

### 24.6. MAXIMUM SHEAR STRAIN ENERGY THEORY

This theory is due to Mises and Henky and is known as Mises-Henky theory. This theory is also called the *energy of distortion theory*. According to this theory, the failure of a material occurs when the total shear strain energy per unit volume in the stressed material reaches a value equal to the shear strain energy per unit volume at the elastic limit in the simple tension test.

The total shear strain energy\* (or energy of distortion) per unit volume due to principal stresses  $\sigma_1$ ,  $\sigma_2$  and  $\sigma_3$  in a stressed material is given as

$$= \frac{1}{12C} [(\sigma_1 - \sigma_2)^2 + (\sigma_2 - \sigma_3)^2 + (\sigma_3 - \sigma_1)^2] \quad \dots(24.10)$$

The simple tension test is a uniaxial stress system which means the principal stresses are  $\sigma_1, 0, 0$ .

At the elastic limit the tensile stress in simple test is  $\sigma_t^*$ .

Hence at the elastic limit in simple tension test, the principal stresses are  $\sigma_t^*, 0, 0$ .

The shear strain energy per unit volume at the elastic limit in simple tension will be

$$\begin{aligned} &= \frac{1}{12C} [(\sigma_t^* - 0)^2 + (0 - 0)^2 + (0 - \sigma_t^*)^2] \\ & \quad \quad \quad \text{[Here } \sigma_1 = \sigma_t^*, \sigma_2 = 0, \sigma_3 = 0] \\ &= \frac{1}{12C} [2 \times \sigma_t^{*2}] \quad \dots(24.11) \end{aligned}$$

For the failure of the material,

$$\frac{1}{12C} [(\sigma_1 - \sigma_2)^2 + (\sigma_2 - \sigma_3)^2 + (\sigma_3 - \sigma_1)^2] \geq \frac{1}{12C} [2 \times (\sigma_t^*)^2] \quad \dots(24.12)$$

or

$$(\sigma_1 - \sigma_2)^2 + (\sigma_2 - \sigma_3)^2 + (\sigma_3 - \sigma_1)^2 \geq 2 \times (\sigma_t^*)^2$$

For actual design (*i.e.*, when some quantity is to be calculated) in stead of  $\sigma_t^*$ , the allowable stress ( $\sigma_t$ ) in simple tension should be used where

$$\sigma_t = \frac{\sigma_t^*}{\text{Safety factor}}$$

Hence for design purpose, the following equation should be used :

$$(\sigma_1 - \sigma_2)^2 + (\sigma_2 - \sigma_3)^2 + (\sigma_3 - \sigma_1)^2 = 2 \times (\sigma_t)^2 \quad \dots(24.13)$$

The equation (24.13) should be used for design purpose only. It should not be used for determining the failure of the material due to maximum shear strain energy.

For a two-dimensional stress system,  $\sigma_3 = 0$ . Hence the equation (24.13) becomes as

$$(\sigma_1 - \sigma_2)^2 + (\sigma_2)^2 + (-\sigma_1)^2 = 2 \times (\sigma_t)^2$$

or

$$\sigma_1^2 + \sigma_2^2 - 2\sigma_1\sigma_2 + \sigma_2^2 + \sigma_1^2 = 2 \times \sigma_t^2$$

or

$$2(\sigma_1^2 + \sigma_2^2 - \sigma_1\sigma_2) = 2 \times \sigma_t^2$$

or

$$\sigma_1^2 + \sigma_2^2 - \sigma_1\sigma_2 = \sigma_t^2 \quad \dots[24.13(A)]$$

**Problem 24.9.** For the data given in Problem 24.2, determine whether the failure of the material will occur or not according to maximum shear strain energy.

**Sol.** Data from Problem 24.2 :

$$\sigma_1 = 200 \text{ N/mm}^2 \text{ (tensile)}$$

$$\sigma_2 = 100 \text{ N/mm}^2 \text{ (tensile)}$$

$$\sigma_3 = 50 \text{ N/mm}^2 \text{ (compressive)} = -50 \text{ N/mm}^2$$

Elastic limit in simple tension,  $\sigma_t^* = 200 \text{ N/mm}^2$ ,  $\mu = 0.3$

\*Refer to Art. 24.9.

The total shear strain energy per unit volume due to principal stresses  $\sigma_1$ ,  $\sigma_2$  and  $\sigma_3$  in the stressed material

$$\begin{aligned} &= \frac{1}{12C} [(\sigma_1 - \sigma_2)^2 + (\sigma_2 - \sigma_3)^2 + (\sigma_3 - \sigma_1)^2] \\ &= \frac{1}{12C} [(200 - 100)^2 + (100 - (-50))^2 + (-50 - 200)^2] \\ &= \frac{1}{12C} [10000 + 22500 + 62500] \\ &= \frac{1}{12C} \times 95000 \quad \dots(i) \end{aligned}$$

The shear strain energy per unit volume at elastic limit in simple tension (here principal stresses are  $\sigma_t^*, 0$  and  $0$ )

$$\begin{aligned} &= \frac{1}{12C} [(\sigma_t^* - 0)^2 + (0 - 0)^2 + (0 - \sigma_t^*)^2] \\ &= \frac{1}{12C} \times 2 \times (\sigma_t^*)^2 \\ &= \frac{1}{12C} \times 2 \times (200)^2 = \frac{1}{12C} \times 80000 \quad \dots(ii) \end{aligned}$$

Now apply the theory of maximum shear strain energy.

If we compare equations (i) and (ii), we find that the total shear strain energy per unit volume due to principal stresses  $\sigma_1$ ,  $\sigma_2$ ,  $\sigma_3$  are more than the shear strain energy per unit volume at elastic limit in simple tension. Hence failure will occur. **Ans.**

**Problem 24.10.** For the data given in the Problem 24.6, determine the diameter of the bolt according to maximum shear strain energy.

**Sol.** Data from Problem 24.6 :

$$P = 9000 \text{ N}; F = 4500 \text{ N}; \sigma_t^* = 225 \text{ N/mm}^2; \text{ Safety factor} = 3, \mu = 0.3$$

$$\text{Allowable stress } (\sigma_t) \text{ in simple tension} = \frac{\sigma_t^*}{\text{Safety factor}}$$

$$\therefore \sigma_t = \frac{225}{3} = 75 \text{ N/mm}^2$$

The other calculated values from Problem 24.6 are :

$$\sigma = \frac{11459}{d^2} \text{ N/mm}^2; \tau = \frac{5729.5}{d^2} \text{ N/mm}^2, \text{ where } d = \text{dia. of bolt.}$$

The maximum and minimum principal stresses are calculated in Problem 24.8 and they are as :

$$\sigma_1 = \frac{13832.5}{d^2} \text{ N/mm}^2 \text{ and } \sigma_2 = \frac{-2373.5}{d^2} \text{ N/mm}^2$$

The third principal stress *i.e.*,  $\sigma_3 = 0$

In this problem, diameter is to be calculated according to the theory of maximum shear strain energy. Hence equation (24.13) will be used.

$$\therefore (\sigma_1 - \sigma_2)^2 + (\sigma_2 - \sigma_3)^2 + (\sigma_3 - \sigma_1)^2 = 2 \times (\sigma_t)^2$$

$$\left[ \frac{13832.5}{d^2} - \left( \frac{-2373.5}{d^2} \right) \right]^2 + \left[ \left( \frac{-2373.5}{d^2} - 0 \right) \right]^2 + \left[ 0 - \frac{13832.5}{d^2} \right]^2 = 2 \times 75^2$$

$$\left[ \frac{13832.5 + 2373.5}{d^2} \right]^2 + \left[ \frac{2373.5}{d^2} \right]^2 + \left[ \frac{-13832.5}{d^2} \right]^2 = 11250$$

$$\frac{26263 \times 10^4}{d^4} + \frac{563.35 \times 10^4}{d^4} + \frac{19134 \times 10^4}{d^4} = 11250$$

$$\frac{45960.35 \times 10^4}{d^4} = 11250$$

$$d^4 = \frac{45960.35 \times 10^4}{11250} = 4.08536 \times 10^4$$

$$d = [4.08536 \times 10^4]^{1/4} = (4.08536)^{1/4} \times 10 = 1.4217 \times 10 = 14.217 \text{ mm. Ans.}$$

**24.7. GRAPHICAL REPRESENTATION OF THEORIES FOR TWO DIMENSIONAL STRESS SYSTEM**

The different theories of failure can be represented graphically for two-dimensional stress system. This means only  $\sigma_1$  and  $\sigma_2$  are existing. The third principal stress is zero i.e.,  $\sigma_3 = 0$ . The principal stress  $\sigma_1$  is taken along x-axis having +ve value to the right of origin O. The principal stress  $\sigma_2$  is taken along y-axis, having +ve value upwards. It will also be assumed that the elastic limit is the same in tension and compression.

Hence  $\sigma_t^* = \sigma_c^* = \sigma^*$  where  $\sigma^*$  = Elastic limit in tension and compression.

Now the theories of failure may be represented graphically as follows :

**1. Maximum principal stress theory.** The criterion of failure according to this theory

Maximum tensile, principal stress,  $\sigma_1 = \sigma_t^* = \sigma^*$

Maximum compressive principal stress,  $\sigma_2 = \sigma_c^* = -\sigma^*$

Fig. 24.1 shows the graphical representation of this theory. The diagram is divided into four quadrant. In 1st quadrant  $\sigma_1$  and  $\sigma_2$  are +ve. In 2nd quadrant  $\sigma_1$  is -ve whereas  $\sigma_2$  is +ve. In 3rd quadrant both  $\sigma_1$  and  $\sigma_2$  are -ve and in 4th quadrant  $\sigma_1$  is +ve and  $\sigma_2$  is -ve. The maximum values of  $\sigma_1 = \pm \sigma^*$  and also maximum value of  $\sigma_2 = \pm \sigma^*$ .

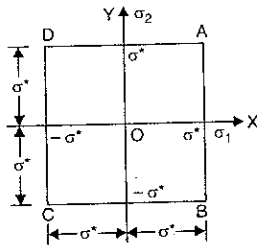

Fig. 24.1. Graphical representation of maximum principal stress theory.

The plotting\* of  $\sigma_1 = \sigma^*$ ,  $\sigma_2 = \sigma^*$ ,  $\sigma_1 = -\sigma^*$  and  $\sigma_2 = -\sigma^*$  will give a square which is shown in Fig. 24.1 by ABCD. Hence the square ABCD represents the graphical representation of the maximum principal stress theory.

The failure of the material will occur if any point having co-ordinates  $(\sigma_1, \sigma_2)$  falls outside the square ABCD.

**2. Maximum principal strain theory.** The criterion of failure according to this theory for two dimensional stress system is

$$\sigma_1 - \mu \sigma_2 = \sigma_t^* = \sigma^* \quad \dots(i)$$

and

$$\sigma_2 - \mu \sigma_1 = \sigma_c^* = -\sigma^* \quad \dots(ii)$$

In these above two equations which represent the equation of a straight line  $\sigma_1$  and  $\sigma_2$  are +ve i.e., they lie in 1st quadrant. At the point A (in Fig. 24.2)  $\sigma_2$  is zero. If this value is substituted in equation (i), we get

$$\sigma_1 = \sigma^*$$

Hence the location of point A is known i.e.,  $OA = \sigma^*$ .

The location of point D is obtained by substituting  $\sigma_1 = 0$  in equation (ii).

Hence  $\sigma_2 = \sigma^*$

Hence  $OD = \sigma^*$

For point E,  $\sigma_2 = OD = \sigma^*$

Substitute this value of  $\sigma_2 = \sigma^*$  in equation (i), we get

$$\sigma_1 - \mu \times \sigma^* = \sigma^* \text{ or } \sigma_1 = \sigma^* + \mu \sigma^* = \sigma^* (1 + \mu).$$

Hence  $DE = \sigma^* (1 + \mu)$ . Hence location of point E is known. Join A to E and produce both sides i.e., towards point G and point L.

For point F,  $\sigma_1 = OA = \sigma^*$

Substitute  $\sigma_1 = \sigma^*$  in equation (ii), we get

$$\sigma_2 - \mu \times \sigma^* = -\sigma^* \text{ or } \sigma_2 = \sigma^* + \mu \sigma^* = \sigma^* (1 + \mu)$$

Hence  $AF = \sigma^* (1 + \mu)$ .

Hence location of point F is known. Join D to F and produce both sides i.e., towards point G and H.

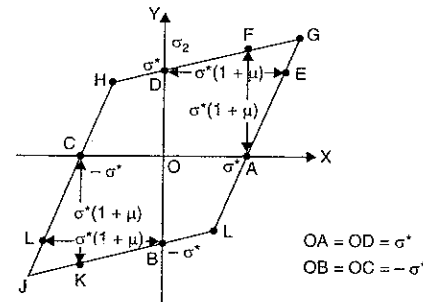

Fig. 24.2. Graphical representation of maximum strain theory.

\*This plotting is like the equations  $x = \sigma^*$ ,  $y = \sigma^*$ ,  $x = -\sigma^*$  and  $y = -\sigma^*$ . The plot of  $x = \sigma^*$  will be a vertical line AB at a distance of  $\sigma^*$  from axis OY. Similarly other plots can be drawn.

For third quadrant the equations (i) and (ii) can be written as

$$\sigma_1 - \mu\sigma_2 = -\sigma^* \quad \dots(iii)$$

$$\sigma_2 - \mu\sigma_1 = -\sigma^* \quad \dots(iv)$$

By using these equations the locations of points *B*, *C*, *K* and *L* can be obtained. Points *B* and *K* can be joined and produced both sides. Similarly point *L* and *C* can be joined and produced both sides. The points *J*, *L* and *H* can be obtained. We will get a parallelogram *HGLJ* as shown in Fig. 24.2, which represents the graphical representation of maximum strain theory.

The failure of the material will occur if any point having co-ordinates  $(\sigma_1, \sigma_2)$  falls outside parallelogram *HGLJH*.

**3. Maximum shear stress theory.** Criterion of failures according to this theory are as follows :

(i) If  $\sigma_1$  and  $\sigma_2$  are like\*(i.e., they are in 1st and 3rd quadrant), the maximum shear stress is  $\frac{1}{2} \times \sigma_1$  (or  $\frac{1}{2} \times \sigma_2$ ) obtained by taking half the difference between  $\sigma_1$  and 0 or  $\sigma_2$  and 0.

Hence failure is represented by

	1st quadrant	3rd quadrant	
$\frac{\sigma_1}{2} = \frac{\sigma^*}{2}$	or $\sigma_1 = \sigma^*$	and $\sigma_1 = -\sigma^*$	
$\frac{\sigma_2}{2} = \frac{\sigma^*}{2}$	or $\sigma_2 = \sigma^*$	and $\sigma_2 = -\sigma^*$	

The lines are drawn according to above equations in the 1st and 3rd quadrant of Fig. 24.3. In first quadrant, line *AE* represent the equation  $\sigma_1 = \sigma^*$  whereas line *DE* represent the equation  $\sigma_2 = \sigma^*$ . In third quadrant, line *CF* represent the equation  $\sigma_1 = -\sigma^*$  and line *BF* represent the equation  $\sigma_2 = -\sigma^*$

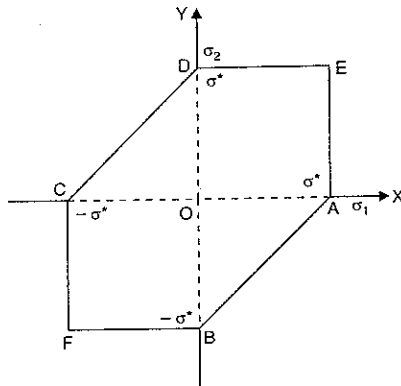

Fig. 24.3. Graphical representation of maximum shear stress theory.

\*Suppose  $\sigma_1$  and  $\sigma_2$  are tensile and are equal in magnitude. The maximum shear stress will not be zero. But it will be equal to  $\frac{\sigma_1}{2}$  or  $\frac{\sigma_2}{2}$ .

(ii) If  $\sigma_1$  and  $\sigma_2$  are of opposite sign (i.e., one is +ve and other is -ve which means they are in 2nd and 4th quadrant), the maximum shear stress is half the difference between  $\sigma_1$  and  $\sigma_2$ .

Hence failure is represented by

$$\frac{1}{2} (\sigma_1 - \sigma_2) = \pm \frac{1}{2} \times \sigma^* \quad \text{or} \quad (\sigma_1 - \sigma_2) = \pm \sigma^*$$

The equation  $\sigma_1 - \sigma_2 = +\sigma^*$  gives  $\sigma_2 = \sigma_1 - \sigma^*$  (which is equivalent to  $y = mx + c$ ). This is the equation of straight line having intercept  $= -\sigma^*$  on *y*-axis and slope = 1 i.e., 45°. This represent the line *BA* in Fig. 24.3.

The equation  $\sigma_1 - \sigma_2 = -\sigma^*$  gives  $\sigma_2 = \sigma_1 + \sigma^*$ . This is also the equation of straight line having intercept  $= +\sigma^*$  on *y*-axis and slope of 45°. This represents the line *CD* in Fig. 24.3. The boundary *ABFCDEA* shown in Fig. 24.3 gives the graphical representation of maximum shear stress theory.

The failure of the material will occur if any point having co-ordinates  $(\sigma_1, \sigma_2)$  falls outside the boundary.

**4. Maximum strain energy theory.** The criterion of failure for two dimensional stress system according to this theory is

$$\sigma_1^2 + \sigma_2^2 - 2\mu\sigma_1 \times \sigma_2 = \sigma_t^{*2} = \sigma^{*2} \quad (\because \sigma_t^* \text{ has been taken} = \sigma^*)$$

The above is the equation of an ellipse with centre at the origin and axes inclined at 45° as shown in Fig. 24.4 along with the boundaries of maximum strain theory and maximum principal stress theory. The ellipse is inscribed in the parallelogram *GLKHG* given by maximum strain theory. The boundaries of the maximum strain theory is shown in Fig. 24.4 as *APBNCQDMA*. The failure of the material will occur if any point having co-ordinates  $(\sigma_1, \sigma_2)$  falls outside this boundary.

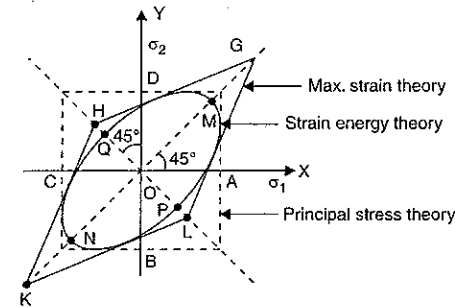

Fig. 24.4. Representation of strain energy theory (Boundary *APBNCQDMA*).

**5. Maximum shear strain theory.** The criterion of failure according to this theory is given by

$$\sigma_1^2 + \sigma_2^2 - \sigma_1 \times \sigma_2 = \sigma_t^{*2} = \sigma^{*2}$$

This is an equation of ellipse with centre at the origin and axes inclined at 45° as shown in Fig. 24.5 along with the boundary of maximum principal stress theory.

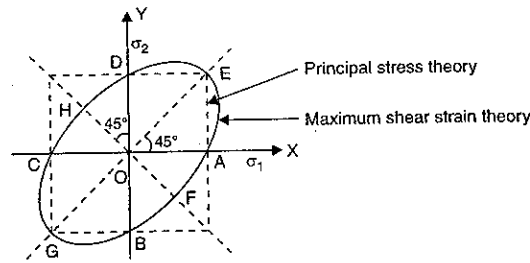

Fig. 24.5. Representation of maximum shear strain theory (Boundary AFBGCHDEA).

The boundary of the maximum strain energy theory is shown in Fig. 24.5 as AFBGCHDEA. The failure of the material will occur if any point having co-ordinates  $(\sigma_1, \sigma_2)$  falls outside this boundary.

#### 24.8. IMPORTANT POINTS FROM THEORIES OF FAILURES USED IN DESIGN

The cause of failure of a material depends not only on the properties of the material but also on the stress system to which it is subjected. The various theories of failure have been explained in the previous article, but no great uniformity of opinion has been reached so far. The followings are the important points from the theories of failures, which should be generally used in design :

1. The maximum principal stress theory should be used in case of brittle materials such as cast iron.
2. The maximum shear stress or maximum shear strain energy theories should be used for ductile materials. These theories give a good approximation. When the mean principal stress is compressive, the shear strain energy should be preferred.
3. The maximum strain theory gives reliable results in particular cases, hence this theory should not be used in general.

In some cases this theory becomes invalid. Let us consider a case where  $\sigma_1 = \sigma_2$  (i.e., equal tensions in two perpendicular directions). Then equation (24.2) for two-dimensional stress system becomes as

$$\sigma_1 - \mu\sigma_2 = \sigma_i^* \quad (\because \sigma_2 = \sigma_1)$$

or

$$\sigma_1 - \mu \times \sigma_1 = \sigma_i^*$$

or

$$\sigma_1 (1 - \mu) = \sigma_i^*$$

or

$$\sigma_1 = \frac{\sigma_i^*}{(1 - \mu)}$$

As  $\mu$  is less than 1, the above equation shows that

$$\sigma_1 > \sigma_i^*$$

This means then tensile stress at failure is more than the stress in simple tension. Experiments donot support this conclusion.

4. The maximum shear stress theory should not be applied in the case where the state of stress consists of triaxial tensile stresses of nearly equal magnitude, reducing the shearing stress to a small magnitude. In this case the failure would be brittle fracture rather than by yielding.

**Problem 24.11.** A hollow mild steel shaft having 100 mm external diameter and 50 mm internal diameter is subjected to a twisting moment of 8 kNm and a bending moment of 2.5 kNm. Calculate the principal stresses and find direct stress which, acting alone, would produce the same (i) maximum elastic strain energy, (ii) maximum elastic shear strain energy, as that produced by the principal stresses acting together. Take Poisson's ratio = 0.25.

(Engineering Services)

**Sol. Given :**

External dia.,  $D = 100 \text{ mm} = 0.1 \text{ m}$

Internal dia.,  $d = 50 \text{ mm} = 0.05 \text{ m}$

Twisting moment,  $T = 8 \text{ kNm} = 8000 \text{ Nm}$

Bending moment,  $M = 2.5 \text{ kNm} = 2500 \text{ Nm}$

Poisson's ratio,  $\mu = 0.25$

Let us first calculate bending stress ( $\sigma_b$ ) due to bending moment and shear stress ( $\tau$ ) due to twisting moment.

$$\text{Bending stress, } \sigma_b = \frac{M}{Z} = \frac{2500}{9.2 \times 10^{-5}}$$

where

$$Z = \frac{I}{y} = \frac{\frac{\pi}{64} [D^4 - d^4]}{\frac{D}{2}}$$

$$= \frac{\pi}{64} [D^4 - d^4] \times \frac{2}{D} = \frac{\pi}{64} [0.1^4 - 0.05^4] \times \frac{2}{0.1}$$

$$= \frac{\pi}{64} [0.0001 - 0.0000625] \times \frac{2}{0.1}$$

$$= 9.2 \times 10^{-5} \text{ m}^3$$

$$= 27.17 \times 10^6 \text{ N/m}^2$$

$$= 27.17 \text{ MN/m}^2$$

$$\text{Shear stress, } \tau = \frac{T}{J} \times R \quad \left[ \because \frac{T}{J} = \frac{\tau}{R} \therefore \tau = \frac{T}{J} \times R \right]$$

$$= \frac{8000}{\frac{\pi}{32} [D^4 - d^4]} \times \frac{D}{2}$$

$$= \frac{8000 \times 32}{\pi (0.1^4 - 0.05^4)} \times \frac{0.1}{2}$$

$$= \frac{8000 \times 16 \times 0.1}{\pi [0.0001 - 0.0000625]}$$

$$= 43.46 \times 10^6 \text{ N/m}^2 = 43.46 \text{ MN/m}^2.$$

(i) Principal stresses ( $\sigma_1$  and  $\sigma_2$ )

Now the principal stresses can be calculated. They are

$$\begin{aligned} \sigma_1 \text{ and } \sigma_2 &= \frac{\sigma_b}{2} \pm \sqrt{\left(\frac{\sigma_b}{2}\right)^2 + \tau^2} \\ &= \frac{27.17}{2} \pm \sqrt{\left(\frac{27.17}{2}\right)^2 + 43.46^2} = 13.585 \pm 45.53 \end{aligned}$$



$$\sigma_1 = 13.585 + 45.53 = 59.115 = \mathbf{59.12 \text{ MN/m}^2} \quad \text{Ans.}$$

$$\sigma_2 = 13.585 - 45.53 = -31.945 \approx \mathbf{-31.95 \text{ MN/m}^2} \quad \text{Ans.}$$

and  
(ii) Single direct stress which would produce the same maximum elastic strain energy as produced by the principal stresses acting together.

Let  $\sigma$  = single direct stress

$$\text{Strain energy due to single direct stress} = \frac{1}{2E} \times \sigma^2 \quad \dots(i)$$

$$\text{Max. strain energy produced by principal stresses} = \frac{1}{2E} (\sigma_1^2 + \sigma_2^2 - 2\mu \sigma_1 \times \sigma_2) \quad \dots(ii)$$

Equating the two strain energies given by equations (i) and (ii), we get

$$\frac{1}{2E} [\sigma_1^2 + \sigma_2^2 - 2\mu \sigma_1 \times \sigma_2] = \frac{1}{2E} \times \sigma^2$$

$$\sigma_1^2 + \sigma_2^2 - 2\mu \sigma_1 \times \sigma_2 = \sigma^2$$

$$59.12^2 + (-31.95)^2 - 2 \times 0.25 \times 59.12 \times (-31.95) = \sigma^2$$

$$3495 + 1020.8 + 944.4 = \sigma^2$$

$$5460.2 = \sigma^2$$

$$\therefore \sigma = \sqrt{5460.2} = 73.89 \approx \mathbf{73.9 \text{ MN/m}^2} \quad \text{Ans.}$$

(iii) Single direct stress which would produce the same maximum elastic shear strain energy as produced by the principal stresses acting together.

Shear strain energy by single direct stress

$$= \frac{1}{12C} [(\sigma - 0)^2 + (0 - 0)^2 + (0 - \sigma)^2]$$

[ $\because$  Single stress is uniaxial stress system i.e.,  $\sigma, 0, 0$ ]

$$= \frac{1}{12C} [\sigma^2 + \sigma^2] = \frac{1}{12C} \times 2\sigma^2 \quad \dots(iii)$$

Max. shear strain energy due to principal stresses  $\sigma_1, \sigma_2, 0$

$$= \frac{1}{12C} [(\sigma_1 - \sigma_2)^2 + (\sigma_2 - 0)^2 + (0 - \sigma_1)^2] \quad \text{[Refer to equation (24.10)]}$$

$$= \frac{1}{12C} [(\sigma_1 - \sigma_2)^2 + \sigma_2^2 + \sigma_1^2]$$

$$= \frac{1}{12C} [\sigma_1^2 + \sigma_2^2 - 2\sigma_1\sigma_2 + \sigma_2^2 + \sigma_1^2]$$

$$= \frac{1}{12C} [2(\sigma_1^2 + \sigma_2^2 - \sigma_1\sigma_2)] \quad \dots(iv)$$

Equating the two shear strain energies given by equations (iii) and (iv), we get

$$\frac{1}{12C} \times 2\sigma^2 = \frac{1}{12C} \times 2 \times (\sigma_1^2 + \sigma_2^2 - \sigma_1\sigma_2)$$

$$\sigma^2 = \sigma_1^2 + \sigma_2^2 - \sigma_1\sigma_2 \quad \left[ \text{Cancelling } \frac{1}{12C} \times 2 \text{ to both sides} \right]$$

$$= 59.12^2 + (-31.95)^2 - (59.12)(-31.95)$$

$$= 3495 + 1020.8 + 1888.8$$

$$= 6404.6$$

$$\therefore \sigma = \sqrt{6404.6} = \mathbf{80.03 \text{ MN/m}^2} \quad \text{Ans.}$$

**Problem 24.12.** A cylindrical shell made of mild steel plate and 1.2 m in diameter is to be subjected to an internal pressure of 1.5 MN/m<sup>2</sup>. If the material yields at 200 MN/m<sup>2</sup>, calculate the thickness of the plate on the basis of the following three theories, assuming a factor of safety 3 in each case :

(i) maximum principal stress theory,

(ii) maximum shear stress theory, and

(iii) maximum shear strain energy theory.

(Engineering Services)

**Sol.** Given :

Diameter,  $d = 1.2 \text{ m}$  ; Internal pressure,  $p = 1.5 \text{ MN/m}^2$

Yield stress,  $\sigma_t^* = 200 \text{ MN/m}^2$

Factor of safety = 3

$$\text{Permissible stress in simple tension, } \sigma_t = \frac{\sigma_t^*}{\text{Safety factor}} = \frac{200}{3} \text{ MN/m}^2$$

Let  $t$  = thickness of the plate.

Let us first calculate the circumferential (or hoop) stress and longitudinal stress produced by internal pressure in the material of the shell.

$$\text{Circumferential stress, } \sigma_c = \frac{p \times d}{2t} = \frac{1.5 \times 1.2}{2 \times t} = \frac{0.9}{t} \text{ MN/m}^2$$

$$\text{Longitudinal stress, } \sigma_L = \frac{p \times d}{4t} = \frac{1.5 \times 1.2}{4 \times t} = \frac{0.45}{t} \text{ MN/m}^2$$

At any point, in the material of cylindrical, the above two stresses which are tensile are perpendicular to each other. Also there is no shear stress. Hence these stresses are also principal stresses.

$$\therefore \sigma_1 = \sigma_c = \frac{0.9}{t} \text{ MN/m}^2$$

$$\text{and } \sigma_2 = \sigma_L = \frac{0.45}{t} \text{ MN/m}^2 \quad \text{[Here } \sigma_1 > \sigma_2 \text{]}$$

(i) Thickness of plate on the basis of maximum principal stress theory

According to maximum principal stress theory for design purpose (here  $t$  is to be calculated)

$$\sigma_1 = \sigma_t$$

$$\text{or } \frac{0.9}{t} = \frac{200}{3} \quad \left( \because \sigma_t = \frac{200}{3} \text{ MN/m}^2 \right)$$

$$\text{or } t = \frac{3 \times 0.9}{200} = 0.0135 \text{ m} = \mathbf{13.5 \text{ mm.}} \quad \text{Ans.}$$

(ii) Thickness of plate on the basis of maximum shear stress theory

Here both the principal stresses are tensile and  $\sigma_1 > \sigma_2$ . Hence maximum shear stress

due to these principal stresses will be  $\left(\frac{\sigma}{2}\right)$ . And the maximum shear stress due to permissible

stress in simple tension will be  $\frac{1}{2} \times \sigma_t$ . Hence, we get

$$\frac{1}{2} \times \sigma_1 = \frac{1}{2} \times \sigma_t$$

$$\begin{aligned} \text{or} \quad & \sigma_1 = \sigma_t \\ \text{or} \quad & \frac{0.9}{t} = \frac{200}{3} \\ \therefore & t = \frac{0.9 \times 3}{200} = 0.0135 \text{ m} = \mathbf{13.5 \text{ mm. Ans.}} \end{aligned}$$

(iii) Thickness of the plate on the basis of maximum shear strain energy theory

For two-dimensional stress system for design purpose in case of maximum, shear strain energy, equation [24.13(A)] is used

$$\begin{aligned} \therefore \quad & \sigma_1^2 + \sigma_2^2 - \sigma_1 \times \sigma_2 = \sigma_t^2 \\ \text{or} \quad & \left(\frac{0.9}{t}\right)^2 + \left(\frac{0.45}{t}\right)^2 - \frac{0.9}{t} \times \frac{0.45}{t} = \left(\frac{200}{3}\right)^2 \\ \text{or} \quad & \frac{0.45^2}{t^2} [4 + 1 - 2] = \frac{40000}{9} \end{aligned}$$

$$\text{or} \quad \frac{0.45^2}{t^2} \times 3 = \frac{40000}{9}$$

$$\text{or} \quad t^2 = \frac{0.45^2 \times 3 \times 9}{40000} = 1.3668 \times 10^{-4}$$

$$\text{or} \quad t = \sqrt{1.3668} \times 10^{-2} = 1.169 \times 10^{-2} = 0.01169 \approx \mathbf{0.0117 \text{ mm. Ans.}}$$

**Problem 24.13.** In a two-dimensional stress system, the direct stresses on two mutually perpendicular planes are  $120 \text{ MN/m}^2$  and  $\sigma \text{ MN/m}^2$ . These planes also carry a shear stress of  $40 \text{ MN/m}^2$ . If factor of safety on elastic limit is 3, then find :

(i) the value of  $\sigma$  when shear strain energy is minimum and

(ii) the elastic limit of the material in simple tension.

**Sol.** Given :

Two-dimensional stress system.

$$\sigma_x = 120 \text{ MN/m}^2 ; \sigma_y = \sigma, \tau_{xy} = 40 \text{ MN/m}^2$$

Factor of safety = 3

Let us first find the principal stresses ( $\sigma_1$  and  $\sigma_2$ ). They are given as

$$\begin{aligned} \sigma_1 \text{ and } \sigma_2 &= \frac{\sigma_x + \sigma_y}{2} \pm \sqrt{\left(\frac{\sigma_x - \sigma_y}{2}\right)^2 + \tau_{xy}^2} \\ &= \frac{120 + \sigma}{2} \pm \sqrt{\left(\frac{120 - \sigma}{2}\right)^2 + 40^2} \end{aligned}$$

$$\therefore \quad \sigma_1 = \frac{120 + \sigma}{2} + \sqrt{\left(\frac{120 - \sigma}{2}\right)^2 + 40^2} = \frac{120 + \sigma}{2} + x$$

$$\text{where } x = \sqrt{\left(\frac{120 - \sigma}{2}\right)^2 + 40^2}$$

$$\text{and} \quad \sigma_2 = \frac{120 + \sigma}{2} - \sqrt{\left(\frac{120 - \sigma}{2}\right)^2 + 40^2} = \frac{120 + \sigma}{2} - x.$$

(i) Value of  $\sigma$  when shear strain energy is minimum

Shear strain energy is given by equation (24.10) as

$$U = \frac{1}{12C} [(\sigma_1 - \sigma_2)^2 + (\sigma_2 - \sigma_3)^2 + (\sigma_3 - \sigma_1)^2] \quad \dots \text{ for three-dimensional stress system}$$

$$= \frac{1}{12C} [(\sigma_1 - \sigma_2)^2 + (\sigma_2 - 0)^2 + (0 - \sigma_1)^2] \quad \dots \text{ for two-dimensional stress system } (\sigma_3 = 0)$$

$$\begin{aligned} &= \frac{1}{12C} [(2x)^2 + \sigma_2^2 + \sigma_1^2] \\ & \quad \left[ \because \sigma_1 - \sigma_2 = \left(\frac{120 + \sigma}{2} + x\right) - \left(\frac{120 + \sigma}{2} - x\right) = 2x \right] \\ &= \frac{1}{12C} [4x^2 + \sigma_1^2 + \sigma_2^2] \quad \dots (i) \end{aligned}$$

Let us find the values of  $\sigma_1^2 + \sigma_2^2$

$$\sigma_1^2 = \left[\frac{120 + \sigma}{2} + x\right]^2 \quad \text{and} \quad \sigma_2^2 = \left[\frac{120 + \sigma}{2} - x\right]^2$$

$$\therefore \quad \sigma_1^2 + \sigma_2^2 = \left[\frac{120 + \sigma}{2} + x\right]^2 + \left[\frac{120 + \sigma}{2} - x\right]^2 = 2 \left[ \left(\frac{120 + \sigma}{2}\right)^2 + x^2 \right]$$

Substituting this value in equation (i), we get

$$\begin{aligned} U &= \frac{1}{12C} \left[ 4x^2 + 2 \left\{ \left(\frac{120 + \sigma}{2}\right)^2 + x^2 \right\} \right] \\ &= \frac{1}{12C} \left[ 6x^2 + 2 \left(\frac{120 + \sigma}{2}\right)^2 \right] \\ &= \frac{1}{6C} \left[ 3x^2 + \left(\frac{120 + \sigma}{2}\right)^2 \right] \end{aligned}$$

Now substitute the value of  $x^2$  in above equation  $x = \sqrt{\left(\frac{120 - \sigma}{2}\right)^2 + 40^2}$

$$\therefore \quad x^2 = \left(\frac{120 - \sigma}{2}\right)^2 + 40^2$$

$$\begin{aligned} \therefore \quad U &= \frac{1}{6C} \left[ 3 \left\{ \left(\frac{120 - \sigma}{2}\right)^2 + 40^2 \right\} + \left(\frac{120 + \sigma}{2}\right)^2 \right] \\ &= \frac{1}{6C} \left[ 3 \left\{ \left(60 - \frac{\sigma}{2}\right)^2 + 40^2 \right\} + \left(60 + \frac{\sigma}{2}\right)^2 \right] \\ &= \frac{1}{6C} \left[ 3 \left\{ 3600 + \frac{\sigma^2}{4} - 60\sigma + 1600 \right\} + \left\{ 3600 + \frac{\sigma^2}{4} + 60\sigma \right\} \right] \end{aligned}$$

$$= \frac{1}{6C} [14400 + \sigma^2 - 120\sigma + 1600]$$

$$= \frac{1}{6C} [\sigma^2 - 120\sigma + 16000]$$

For shear strain energy to be minimum,  $\frac{dU}{d\sigma} = 0$

or  $2\sigma - 120 = 0$

$$\therefore \sigma = \frac{120}{2} = 60 \text{ MN/m}^2. \text{ Ans.}$$

(ii) Elastic limit of the material in simple tension ( $\sigma_t^*$ )

Let us first find the values of principal stresses ( $\sigma_1$  and  $\sigma_2$ )

$$\sigma_1 = \frac{120 + \sigma}{2} + \sqrt{\left(\frac{120 - \sigma}{2}\right)^2 + 40^2}$$

$$= \frac{120 + 60}{2} + \sqrt{\left(\frac{120 - 60}{2}\right)^2 + 40^2} \quad (\because \sigma = 60)$$

$$= 90 + \sqrt{900 + 1600} = 90 + \sqrt{2500}$$

$$= 90 + 50 = 140 \text{ MN/m}^2$$

and  $\sigma_2 = 90 - 50 = 40 \text{ MN/m}^2$

Let  $\sigma_t$  = permissible stress in simple tension.

Using equation [24.13(A)], we get

$$\sigma_1^2 + \sigma_2^2 - \sigma_1\sigma_2 = \sigma_t^2$$

$$140^2 + 40^2 - 140 \times 40 = \sigma_t^2$$

$$19600 + 1600 - 5600 = \sigma_t^2$$

or  $\sigma_t = \sqrt{15600} = 124.89 \approx 124.9 \text{ MN/m}^2$

$$\therefore \sigma_t^* = \text{Safety factor} \times \sigma_t = 3 \times 124.9 = 374.7 \text{ MN/m}^2. \text{ Ans.}$$

**Problem 24.14.** A thick cylindrical pressure vessel of inner radius 150 mm is subjected to an internal pressure of 80 MPa. Calculate the wall thickness based upon the

(i) maximum principal stress theory, and

(ii) total strain energy theory.

Take Poisson's ratio = 0.30 and yield strength = 300 MPa.

**Sol.** Given :

Inner radius,  $r_1 = 150 \text{ mm} = 0.15 \text{ m}$ ,

Internal pressure,  $p_1 = 80 \text{ MPa}$

Poisson's ratio,  $\mu = 0.30$

Yield strength,  $\sigma_t^* = 300 \text{ MPa}$

In case of thick\* cylinders the maximum value of  $\sigma_c$  and  $\sigma_r$  occurs at the inner radius  $r_1$ .

The three principal stresses at inner radius ' $r_1$ ' are given as

(i) Radial stress,  $\sigma_r$  which is compressive and is equal to  $p_1$  at radius  $r_1$

(ii) Circumferential stress  $\sigma_c$  which is tensile and is equal to

$$\sigma_c = \frac{p_1 r_1^2}{r_2^2 - r_1^2} \left[ \frac{r_2^2}{r_1^2} + 1 \right] = \frac{p_1 r_1^2}{(r_2^2 - r_1^2)} \frac{(r_2^2 + r_1^2)}{r_1^2}$$

$$= \frac{p_1}{(r_2^2 - r_1^2)} \times (r_2^2 + r_1^2)$$

$$= p_1 \left( \frac{r_2^2 + r_1^2}{r_2^2 - r_1^2} \right) = \frac{p_1 \left[ \left( \frac{r_2}{r_1} \right)^2 + 1 \right]}{\left[ \left( \frac{r_2}{r_1} \right)^2 - 1 \right]} = p_1 \left( \frac{K^2 + 1}{K^2 - 1} \right), \text{ where } K = \frac{r_2}{r_1}$$

$$(iii) \text{ Longitudinal stress, } \sigma_L = \frac{p_1 r_1^2}{r_2^2 - r_1^2} = \frac{p_1 \times \frac{r_1^2}{r_1^2}}{\frac{r_2^2}{r_1^2} - \frac{r_1^2}{r_1^2}} = \frac{p_1}{\left( \frac{r_2}{r_1} \right)^2 - 1} = \frac{p_1}{K^2 - 1}$$

This stress is also tensile.

Out of the three principal stresses, the circumferential stress is maximum. And if there is no longitudinal stress in the cylindrical shell, then we shall have two principal stresses at inner radius which are :

$$\sigma_1 = \sigma_c = p_1 \left( \frac{K^2 + 1}{K^2 - 1} \right) \text{ (tensile)}$$

$$\sigma_2 = \sigma_r = p_1 \text{ at inner radius (compressive)} = -p_1$$

$$\sigma_3 = \sigma_L = 0.$$

(i) Thickness of the wall based on maximum principal stress theory.

According to maximum principal stress theory :

[Please note that for failure  $\sigma_1 \geq \sigma_t^*$ . But for design  $\sigma_1 \leq \sigma_t^*$ .  
Actually  $\sigma_1 = \sigma_t$  where  $\sigma_t = \sigma_t^*/\text{Safety factor}$ ]

$$\sigma_1 \leq \sigma_t^*$$

or  $p_1 \left( \frac{K^2 + 1}{K^2 - 1} \right) \leq 300 \quad (\because \sigma_t^* = 300 \text{ MPa})$

or  $80 \left( \frac{K^2 + 1}{K^2 - 1} \right) \leq 300 \quad (\because p_1 = 80 \text{ MPa})$

or  $\frac{K^2 + 1}{K^2 - 1} \leq \frac{300}{80} \leq 3.75$

or  $K^2 + 1 \leq 3.75K^2 - 3.75$

or  $4.75 \leq 2.75K^2$

or  $2.75K^2 \geq 4.75$

or  $K \geq \sqrt{\frac{4.75}{2.75}} \text{ or } 1.314$

But  $K = \frac{r_2}{r_1}$

$$\therefore \frac{r_2}{r_1} \geq 1.314$$

\*Please refer to chapter 18 of thick cylinders.

$$\text{or } r_2 \geq 1.314 \times r_1 \text{ or } 1.314 \times 150 \text{ or } 197.1 \quad (\because r_1 = 150 \text{ mm})$$

$$\therefore r_2 \geq 197.1 \text{ mm.}$$

Let us take it equal to 197.1 mm.

$$r_2 = 197.1 \text{ mm.}$$

$\therefore$  Thickness of wall =  $r_2 - r_1 = 197.1 - 150 = 47.1 \text{ mm. Ans.}$

(ii) Thickness of wall based on maximum strain energy theory.

According to maximum strain energy theory for two-dimensional stress system [Refer to equation (24.7)], we have

$$\sigma_1^2 + \sigma_2^2 - 2\mu \sigma_1 \sigma_2 \leq \sigma_t^{*2}$$

[For failure L.H.S. should be  $\geq \sigma_t^{*2}$  and for design it should be  $\leq \sigma_t^{*2}$ ]

Substituting the values of  $\sigma_1$  and  $\sigma_2$ , we get

$$\left[ p_1 \left( \frac{K^2 + 1}{K^2 - 1} \right) \right]^2 + (-p_1)^2 - 2\mu \left[ p_1 \left( \frac{K^2 + 1}{K^2 - 1} \right) \right] (-p_1) \leq \sigma_t^{*2}$$

$$p_1^2 \left[ \left( \frac{K^2 + 1}{K^2 - 1} \right)^2 + 1 + 2\mu \left( \frac{K^2 + 1}{K^2 - 1} \right) \right] \leq (\sigma_t^{*})^2$$

$$p_1^2 \left[ \frac{(K^2 + 1)^2 + (K^2 - 1)^2 + 2\mu(K^2 + 1)(K^2 - 1)}{(K^2 - 1)^2} \right] \leq (\sigma_t^{*})^2$$

$$p_1^2 \left[ \frac{K^4 + 1 + 2K^2 + K^4 + 1 - 2K^2 + 2\mu(K^4 + 1)}{(K^2 - 1)^2} \right] \leq (\sigma_t^{*})^2$$

$$p_1^2 \left[ \frac{2K^4 + 2 + 2\mu(K^4 - 1)}{(K^2 - 1)^2} \right] \leq (\sigma_t^{*})^2$$

$$p_1^2 \left[ \frac{2K^4(1 + \mu) + 2(1 - \mu)}{(K^2 - 1)^2} \right] \leq (\sigma_t^{*})^2$$

$$\frac{2p_1^2}{(K^2 - 1)^2} [K^4(1 + \mu) + (1 - \mu)] \leq (\sigma_t^{*})^2$$

But  $p_1 = 80$  and  $\sigma_t^* = 300$ , hence the above equation becomes as

$$2 \times 80^2 \left[ \frac{K^4(1 + 0.3) + (1 - 0.3)}{(K^2 - 1)^2} \right] \leq 300^2$$

$$\frac{K^4 \times 1.3 + 0.7}{(K^2 - 1)^2} \leq \frac{300^2}{2 \times 80^2} \text{ or } 7.03$$

$$1.3K^4 + 0.7 \leq 7.03(K^2 - 1)^2$$

$$\leq 7.03(K^4 + 1 - 2K^2)$$

$$\leq 7.03K^4 + 7.03 - 14.06K^2$$

$$0 \leq 7.03K^4 + 7.03 - 14.06K^2 - 1.3K^4 - 0.7$$

$$\leq (7.03 - 1.3)K^4 - 14.06K^2 + (7.03 - 0.7)$$

$$\leq 5.73K^4 - 14.06K^2 + 6.33$$

$$5.73K^4 - 14.06K^2 + 6.33 \geq 0$$

$$\text{or } K^4 - \frac{14.06}{5.73}K^2 + \frac{6.33}{5.73} = 0$$

(Taking limiting case)

$$\text{or } K^4 - 2.45K^2 + 1.1 = 0$$

$$\text{or } K^2 = \frac{2.45 \pm \sqrt{2.45^2 - 4 \times 1 \times 1.1}}{2}$$

$$= 0.592 \text{ or } 1.858$$

$$\therefore K = \sqrt{0.592} \text{ or } \sqrt{1.858}$$

$$= 0.769 \text{ or } 1.363$$

But  $K \neq 0.769$  as  $K = \frac{r_2}{r_1}$  and  $r_2$  is more than  $r_1$  and  $K$  is more than 1.

$$\therefore K = 1.363 \text{ or } \frac{r_2}{r_1} = 1.363$$

$$\therefore r_2 = 1.363 \times r_1 = 1.363 \times 150 = 204.45 \text{ mm}$$

$\therefore$  Thickness of wall =  $r_2 - r_1 = 204.45 - 150 = 54.45 \text{ mm. Ans.}$

#### 24.9. ENERGY OF DISTORTION (OR SHEAR STRAIN ENERGY)

The total strain energy per unit volume is given by equation (24.5) as

$$U = \frac{1}{2E} [(\sigma_1^2 + \sigma_2^2 + \sigma_3^2) - 2\mu(\sigma_1\sigma_2 + \sigma_2\sigma_3 + \sigma_3\sigma_1)]$$

The above energy can be split up into the two strain energies as :

(i) Strain energy of distortion (shear strain energy)

(ii) Strain energy of uniform compression or tension (Volumetric strain energy or energy of dilation)

The principal strains ( $e_1, e_2, e_3$ ) in the direction of principal stresses ( $\sigma_1, \sigma_2$  and  $\sigma_3$ ) respectively are given by

$$e_1 = \frac{1}{E} [\sigma_1 - \mu(\sigma_2 + \sigma_3)]$$

$$e_2 = \frac{1}{E} [\sigma_2 - \mu(\sigma_3 + \sigma_1)]$$

$$e_3 = \frac{1}{E} [\sigma_3 - \mu(\sigma_1 + \sigma_2)]$$

Adding, we get

$$e_1 + e_2 + e_3 = \frac{1}{E} [(\sigma_1 + \sigma_2 + \sigma_3) - 2\mu(\sigma_1 + \sigma_2 + \sigma_3)]$$

$$= \frac{(\sigma_1 + \sigma_2 + \sigma_3)}{E} (1 - 2\mu)$$

But  $e_1 + e_2 + e_3 =$  Volumetric strain ( $e_v$ )

$$\therefore e_v = \frac{(\sigma_1 + \sigma_2 + \sigma_3)}{E} (1 - 2\mu)$$

Now the two important points are

(a) If  $\sigma_1 + \sigma_2 + \sigma_3 = 0$ , then  $e_v = 0$ .

The above result shows that if sum of the three principal stresses is zero then volumetric strain is zero. This means there is no volumetric change. Only distortion occurs.

(b) If  $\sigma_1 = \sigma_2 = \sigma_3$ , then  $e_1 = e_2 = e_3$ . This means the linear strains in all three directions are equal. This also means that there is no distortion. No distortion means there are no shear stresses and no shear strains. But volumetric strains are present due to the presence of  $e_1$ ,  $e_2$  and  $e_3$ . Hence in this case only volumetric change occurs.

### Energy of distortion and energy of dilation

For a general case, let us introduce the notation

$$\frac{\sigma_1 + \sigma_2 + \sigma_3}{3} = p \quad \dots(i)$$

Now the three given principal stresses can be broken into two parts as given below

$$\sigma_1 = p + \sigma_1' \quad \dots(ii)$$

$$\sigma_2 = p + \sigma_2' \quad \dots(iii)$$

$$\sigma_3 = p + \sigma_3' \quad \dots(iv)$$

Adding equations (ii), (iii) and (iv), we get

$$\sigma_1 + \sigma_2 + \sigma_3 = 3p + \sigma_1' + \sigma_2' + \sigma_3' \quad \dots(v)$$

From equation (i),  $\sigma_1 + \sigma_2 + \sigma_3 = 3p$

Hence the above equation (v) becomes as

$$3p = 3p + \sigma_1' + \sigma_2' + \sigma_3'$$

or 
$$\sigma_1' + \sigma_2' + \sigma_3' = 0$$

As the summation of  $\sigma_1'$ ,  $\sigma_2'$  and  $\sigma_3'$  is equal to zero, this means this set of stresses produces distortion only. This has already been stated in important point (a).

The other set of equal stresses  $p, p, p$  (i.e.,  $\sigma_1 = \sigma_2 = \sigma_3$ ) which is a case of uniform tension or compression produces only volumetric changes. This has also been stated in important point (b).

The total strain energy is the sum of strain energy of uniform tension (or compression) and strain energy of distortion. Hence the strain energy of distortion is obtained by subtracting the strain energy of uniform tension (or compression) from the total strain energy.

Total strain energy per unit volume is given by equation (24.5) as

$$U = \frac{1}{2E} [\sigma_1^2 + \sigma_2^2 + \sigma_3^2 - 2\mu(\sigma_1\sigma_2 + \sigma_2\sigma_3 + \sigma_3\sigma_1)]$$

The strain energy of uniform tension (or compression) is produced by a set of equal stresses  $p, p, p$ .

Hence substituting  $\sigma_1 = p, \sigma_2 = p, \sigma_3 = p$  in the above equation, we get strain energy of uniform tension.

$\therefore$  Strain energy of uniform tension per unit volume

$$= \frac{1}{2E} [p^2 + p^2 + p^2 - 2\mu(p \times p + p \times p + p \times p)]$$

$$= \frac{1}{2E} [3p^2 - 2\mu \times 3p^2]$$

$$= \frac{1}{2E} \times 3p^2 \times (1 - 2\mu)$$

But 
$$p = \frac{\sigma_1 + \sigma_2 + \sigma_3}{3}$$

$\therefore$  Strain energy of uniform tension

$$= \frac{1}{2E} \times 3 \times \left( \frac{\sigma_1 + \sigma_2 + \sigma_3}{3} \right)^2 \times (1 - 2\mu)$$

$$= \frac{1}{6E} \times (\sigma_1 + \sigma_2 + \sigma_3)^2 \times (1 - 2\mu)$$

Now the strain energy of distortion can be obtained.

$\therefore$  Strain energy of distortion per unit volume

= Total strain energy - strain energy of uniform tension

$$= \frac{1}{2E} [\sigma_1^2 + \sigma_2^2 + \sigma_3^2 - 2\mu(\sigma_1\sigma_2 + \sigma_2\sigma_3 + \sigma_3\sigma_1)]$$

$$- \frac{1}{6E} (\sigma_1 + \sigma_2 + \sigma_3)^2 \times (1 - 2\mu)$$

$$= \frac{1}{6E} [3(\sigma_1^2 + \sigma_2^2 + \sigma_3^2) - 2\mu(\sigma_1\sigma_2 + \sigma_2\sigma_3 + \sigma_3\sigma_1)]$$

$$- (1 - 2\mu) (\sigma_1 + \sigma_2 + \sigma_3)^2]$$

$$= \frac{1}{6E} [3\sigma_1^2 + 3\sigma_2^2 + 3\sigma_3^2 - 6\mu\sigma_1\sigma_2 - 6\mu\sigma_2\sigma_3 - 6\mu\sigma_3\sigma_1]$$

$$- (1 - 2\mu) \times (\sigma_1^2 + \sigma_2^2 + \sigma_3^2 + 2\sigma_1\sigma_2 + 2\sigma_2\sigma_3 + 2\sigma_3\sigma_1)]$$

$$= \frac{1}{6E} [2\sigma_1^2 + 2\sigma_2^2 + 2\sigma_3^2 - 2\sigma_1\sigma_2 - 2\sigma_2\sigma_3 - 2\sigma_3\sigma_1 - 6\mu\sigma_1\sigma_2$$

$$- 6\mu\sigma_2\sigma_3 - 6\mu\sigma_3\sigma_1 + 2\mu(\sigma_1^2 + \sigma_2^2 + \sigma_3^2) + 2\mu(2\sigma_1\sigma_2 + 2\sigma_2\sigma_3 + 2\sigma_3\sigma_1)]$$

$$= \frac{1}{6E} [(2\sigma_1^2 + 2\sigma_2^2 + 2\sigma_3^2)(1 + \mu) - (2\sigma_1\sigma_2 + 2\sigma_2\sigma_3 + 2\sigma_3\sigma_1)$$

$$- \mu(2\sigma_1\sigma_2 + 2\sigma_2\sigma_3 + 2\sigma_3\sigma_1)]$$

$$= \frac{1}{6E} [(2\sigma_1^2 + 2\sigma_2^2 + 2\sigma_3^2)(1 + \mu) - (2\sigma_1\sigma_2 + 2\sigma_2\sigma_3 + 2\sigma_3\sigma_1)(1 + \mu)]$$

$$= \frac{1 + \mu}{6E} [2\sigma_1^2 + 2\sigma_2^2 + 2\sigma_3^2 - 2\sigma_1\sigma_2 - 2\sigma_2\sigma_3 - 2\sigma_3\sigma_1]$$

$$= \frac{1 + \mu}{6E} [(\sigma_1 - \sigma_2)^2 + (\sigma_2 - \sigma_3)^2 + (\sigma_3 - \sigma_1)^2]$$

But we know that  $E = 2C(1 + \mu)$

Hence the above equation becomes as

$$= \frac{(1 + \mu)}{6 \times 2C(1 + \mu)} [(\sigma_1 - \sigma_2)^2 + (\sigma_2 - \sigma_3)^2 + (\sigma_3 - \sigma_1)^2]$$

$$= \frac{1}{12C} [(\sigma_1 - \sigma_2)^2 + (\sigma_2 - \sigma_3)^2 + (\sigma_3 - \sigma_1)^2]$$

$\therefore$  Strain energy of distortion per unit volume

$$= \frac{1}{12C} [(\sigma_1 - \sigma_2)^2 + (\sigma_2 - \sigma_3)^2 + (\sigma_3 - \sigma_1)^2] \quad \dots(24.14)$$

The equation (24.14) is also known as the equation of **shear strain energy**.

## HIGHLIGHTS

1. For a three-dimensional stress system subjected to principal stresses  $\sigma_1$ ,  $\sigma_2$  and  $\sigma_3$  the equations for criterion of failure and for design according to:

(a) Maximum principal stress theory (or Rankine theory) are:

$$\text{Criterion of failure: } \sigma_1 \geq \sigma_t^* \quad \text{where } \sigma_t^* = \text{Elastic limit in simple tension}$$

$$| \sigma_3 | \geq \sigma_c^* \quad \sigma_c^* = \text{Elastic limit in simple compression}$$

For design:  $\sigma_1 = \sigma_t$  where  $\sigma_t$  = permissible stress in simple tension

$$= \frac{\sigma_t^*}{\text{Safety factor}}$$

(b) Maximum principal strain theory (or Saint Venant Theory)

$$\text{Criterion of failure: } \frac{1}{E} [\sigma_1 - \mu(\sigma_2 + \sigma_3)] \geq \frac{1}{E} \sigma_t^* \quad \text{or} \quad \sigma_1 - \mu(\sigma_2 + \sigma_3) \geq \sigma_t^*$$

$$| [\sigma_3 - \mu(\sigma_1 + \sigma_2)] | \geq \sigma_c^*$$

$$\text{For design: } \sigma_1 - \mu(\sigma_2 + \sigma_3) = \sigma_t$$

$$\text{or} \quad \sigma_3 - \mu(\sigma_1 + \sigma_2) = \sigma_c$$

(c) Maximum shear stress theory (or Guest and Tresca Theory)

$$\text{At failure: } (\sigma_1 - \sigma_3) \geq \sigma_t^*$$

$$\text{For design: } (\sigma_1 - \sigma_3) = \sigma_t \quad \text{where } \sigma_t = \frac{\sigma_t^*}{\text{Safety factor}}$$

(d) Maximum strain energy theory (or Haigh's Theory)

$$\text{At failure } \frac{1}{2E} [\sigma_1^2 + \sigma_2^2 + \sigma_3^2 - 2\mu(\sigma_1\sigma_2 + \sigma_2\sigma_3 + \sigma_3\sigma_1)] \geq \frac{1}{2E} (\sigma_t^*)^2$$

For two-dimensional stress-system:

$$\text{At failure: } \sigma_1^2 + \sigma_2^2 - 2\mu(\sigma_1 \times \sigma_2) \geq (\sigma_t^*)^2$$

$$\text{For design: } \sigma_1^2 + \sigma_2^2 - 2\mu(\sigma_1 \times \sigma_2) = \sigma_t^2$$

(e) Maximum shear strain energy theory (or Mises and Henky Theory or Energy of distortion Theory)

$$\text{Criterion of failure: } (\sigma_1 - \sigma_2)^2 + (\sigma_2 - \sigma_3)^2 + (\sigma_3 - \sigma_1)^2 \geq 2 \times (\sigma_t^*)^2$$

$$\text{For design: } (\sigma_1 - \sigma_2)^2 + (\sigma_2 - \sigma_3)^2 + (\sigma_3 - \sigma_1)^2 \geq 2 \times \sigma_t^2$$

For two-dimensional stress system in case of design

$$\sigma_1^2 + \sigma_2^2 - \sigma_1\sigma_2 = \sigma_t^2.$$

## EXERCISE 24

## (A) Theoretical Questions

- What do you understand by the term "Theories of failure"? Name the important theories of failure.
- Define and explain the following theories of failure:
  - Maximum principal stress theory.
  - Maximum principal strain theory.
  - Maximum shear stress theory.
  - Maximum strain energy theory.
  - Maximum shear strain energy theory.

- Derive an expression for the distortion energy per unit volume when a body is subjected to principal stresses  $\sigma_1$ ,  $\sigma_2$  and  $\sigma_3$ .
- Explain with reasons which theory of failure is best suited for:
  - Ductile materials
  - Brittle material.
- State distortion energy theory for failure. (Engineering Service, 1992 i.e., IES, 1992)

## (B) Numerical Problems

- The principal stresses at a point in an elastic material are 22, N/mm<sup>2</sup> (tensile), 110 N/mm<sup>2</sup> (tensile) and 55 N/mm<sup>2</sup> (compressive).  
If the elastic limit in simple tension is 220 N/mm<sup>2</sup> and  $\mu = 0.3$ , then determine whether the failure of material will occur or not according to
  - Maximum principal stress theory,
  - Maximum principal strain theory,
  - Maximum shear stress theory,
  - Maximum strain energy theory,
  - Maximum shear strain energy theory. [Ans. (i) Yes (ii) No (iii) Yes (iv) Yes (v) Yes]
- Determine the diameter of a bolt which is subjected to an axial pull of 12 kN together with a transverse shear force of 6 kN, when the elastic limit in tension is 300 N/mm<sup>2</sup>, factor of safety = 3 and Poisson's ratio = 0.3 using:
  - Maximum principal stress theory,
  - Maximum principal strain theory,
  - Maximum shear stress theory,
  - Maximum strain energy theory,
  - Maximum shear strain energy theory [Ans. (i) 13.59 mm (ii) 13.925 mm (iii) 14.7 mm (iv) 14.02 mm (v) 14.22 mm]
- A bolt is under an axial thrust of 7.2 kN together with a transverse shear force of 3.6 kN. Calculate the diameter of the bolt according to:
  - Maximum principal stress theory,
  - Maximum shear stress theory,
  - Maximum strain energy theory [Ans. (i) 12.8 mm (ii) 13.8 mm (iii) 13.33 mm]
 Take elastic limit in simple tension = 202 N/mm<sup>2</sup>, factor of safety = 3 and Poisson's ratio = 0.3.
- A steel shaft is subjected to an end thrust producing a stress of 90 MPa and the maximum shearing stress on the surface arising from torsion is 60 MPa. The yield point of the material in simple tension was found to be 300 MPa. Calculate the factor of safety of the shaft according to the following theories:
  - Maximum shear stress theory,
  - Maximum distortion-energy theory. (AMIE, Summer 1977)[Ans. (i) 2.5 (ii) 2.77]
- At a section of a mild steel shaft of diameter 180 mm, the maximum torque is 67.5 kNm and maximum bending moment is 40.5 kNm. The elastic limit in simple tension is 220 N/mm<sup>2</sup>. Determine whether the failure of the material will occur or not according to maximum shear stress theory. If not, then find the factor of safety. [Ans. (i) Not (ii) 1.6]

## Objective Type Questions

## 25.1. OBJECTIVE TYPE QUESTIONS GENERALLY ASKED IN COMPETITIVE EXAMINATIONS

Tick mark (✓) the most appropriate answer of the multiple choices.

- Within elastic limit in a loaded material, stress is
  - inversely proportional to strain
  - directly proportional to strain
  - equal to strain
  - none of the above.
- The ratio of linear stress to linear strain is known as
  - Poisson's ratio
  - bulk modulus
  - modulus of rigidity
  - modulus of elasticity.
- The ratio of lateral strain to longitudinal strain is called
  - Poisson's ratio
  - bulk modulus
  - modulus of rigidity
  - modulus of elasticity.
- The ratio of shear stress to shear strain is called
  - Poisson's ratio
  - bulk modulus
  - modulus of rigidity
  - modulus of elasticity.
- The ratio of normal stress of each face of a solid cube to volumetric strain is called
  - Poisson's ratio
  - bulk modulus
  - modulus of rigidity
  - modulus of elasticity.
- Hook's law holds good upto
  - proportional limit
  - yield point
  - elastic limit
  - plastic limit.
- The property of a material by virtue of which a body returns to its original shape after removal of the load is known as
  - ductility
  - plasticity
  - elasticity
  - resilience.
- A tensile force ( $P$ ) is acting on a body of length ( $L$ ) and area of cross-section ( $A$ ). The change in length would be
  - $\frac{P}{LAE}$
  - $\frac{PE}{AL}$
  - $\frac{PL}{AE}$
  - $\frac{AL}{PE}$

9. The modulus of elasticity (
- $E$
- ) and modulus of rigidity (
- $C$
- ) are related by

(a)  $C = \frac{mE}{3(m-2)}$

(b)  $C = \frac{mE}{2(m+1)}$

(c)  $C = \frac{3(m-2)}{mE}$

(d)  $C = \frac{2(m+1)}{mE}$

where  $\frac{1}{m}$  = Poisson's ratio.

10. The modulus of elasticity (
- $E$
- ) and bulk modulus (
- $K$
- ) are related by

(a)  $K = \frac{mE}{3(m-2)}$

(b)  $K = \frac{mE}{2(m+1)}$

(c)  $K = \frac{3(m-2)}{mE}$

(d)  $K = \frac{2(m+1)}{mE}$

where  $\frac{1}{m}$  = Poisson's ratio.

11. The elongation produced in a rod (by its own weight) of length (
- $l$
- ) and diameter (
- $d$
- ) rigidly fixed at the upper end and hanging is equal to

(a)  $\frac{wl}{2E}$

(b)  $\frac{wl^2}{2E}$

(c)  $\frac{wl^3}{2E}$

(d)  $\frac{wl^4}{2E}$

where  $w$  = weight per unit volume of the rod, $E$  = modulus of elasticity.

12. The ratio of modulus of rigidity to modulus of elasticity for a Poisson's ratio of 0.25 would be

(a) 0.5

(b) 0.4

(c) 0.3

(d) 1.0.

13. The ratio of bulk modulus to modulus of elasticity for a Poisson's ratio of 0.25 would be

(a)  $\frac{2}{3}$

(b)  $\frac{1}{3}$

(c)  $\frac{4}{3}$

(d) 1.0.

14. The relation between modulus of elasticity (
- $E$
- ), modulus of rigidity (
- $C$
- ) and bulk modulus (
- $K$
- ) is given by

(a)  $E = \frac{3KC}{C+9K}$

(b)  $E = \frac{9KC}{C+3K}$

(c)  $E = \frac{C+9K}{3KC}$

(d)  $E = \frac{C+3K}{9KC}$

15. The ratio of modulus of rigidity to bulk modulus for a Poisson's ratio of 0.25 would be

(a)  $\frac{2}{3}$

(b)  $\frac{2}{5}$

(c)  $\frac{3}{5}$

(d) 1.0.

16. The work done in producing strain on a material per unit volume is called

(a) resilience

(b) ductility

(c) elasticity

(d) plasticity.

17. The property by virtue of which a metal can be beaten into plates is called  
 (a) ductility (b) malleability  
 (c) resilience (d) plasticity.
18. Choose the wrong statement  
 (a) Elongation produced in a rod (by its own weight) which is rigidly fixed at the upper end and hanging is equal to that produced by a load half its weight applied at the end.  
 (b) The stress at any section of a rod on account of its own weight is directly proportional to the distance of the section from the lower end.  
 (c) Modulus of elasticity is having the same unit as stress.  
 (d) If a material expands freely due to heating, it will develop thermal stresses.
19. A rod of length ( $l$ ) tapers uniformly from a diameter  $D_1$  to a diameter  $D_2$  and carries an axial tensile load  $P$ . The extension of the rod would be  
 (a)  $\frac{\pi Pl}{4ED_1D_2}$  (b)  $\frac{4Pl}{\pi ED_1D_2}$   
 (c)  $\frac{\pi EPl}{4D_1D_2}$  (d)  $\frac{4PEl}{\pi D_1D_2}$
20. If in question 19, the rod is of uniform diameter ( $D$ ), then extension would be  
 (a)  $\frac{\pi Pl}{4ED^2}$  (b)  $\frac{4Pl}{\pi ED^2}$   
 (c)  $\frac{\pi EPl}{4D^2}$  (d)  $\frac{4PEl}{\pi D^2}$
21. A rod of length  $l$  and cross-sectional area  $A$  rotates about an axis passing through one end of the rod. The extension produced in the bar due to centrifugal forces would be  
 (a)  $\frac{w\omega l^2}{3E}$  (b)  $\frac{w\omega^2 l^3}{gE}$   
 (c)  $\frac{w\omega^2 l^3}{3gE}$  (d)  $\frac{3gE}{w\omega^2 l^3}$
22. For the bars of composite section,  
 (a) the load carried by different materials is the same as the total external load  
 (b) the extension in different materials is different  
 (c) the total external load is equal to the total sum of the loads carried by different materials  
 (d) strain in all materials is equal  
 (e) both (c) and (d).
23. Two materials are having modulus of elasticities, modulus of rigidities and bulk modulus as  $(E_1, E_2)$ ;  $(C_1, C_2)$  and  $(K_1, K_2)$ . The modulus ratio is given by  
 (a)  $\frac{E_1}{C_2}$  (b)  $\frac{E_1}{K_2}$   
 (c)  $\frac{E_1}{E_2}$  (d)  $\frac{C_1}{K_2}$

24. For uniform strength, a bar which is fixed at the upper end and is subjected to an external load  $P$  at the lower end, the area ( $A$ ) at any section at a distance  $x$  from the lower end is given by  
 (a)  $A_2 e^{\frac{w}{\alpha x}}$  (b)  $A_2 e^{\frac{\sigma}{wx}}$   
 (c)  $A_2 e^{\frac{wx}{\sigma}}$  (d)  $A_2 \times \frac{\sigma}{wx}$   
 where  $A_2$  = area at the lower end,  $w$  = weight per unit volume  
 $\sigma$  = uniform stress intensity in the bar.
25. The thermal stress is given by  
 (a)  $E\alpha T$  (b)  $\frac{ET}{\alpha}$   
 (c)  $\frac{E\alpha}{T}$  (d)  $\frac{1}{E\alpha T}$   
 where  $\alpha$  = co-efficient of linear expansion,  
 $T$  = rise in temperature.
26. The proof resilience is given by  
 (a)  $\frac{2\sigma^2}{E}$  (b)  $\frac{2E}{\sigma^2}$   
 (c)  $\frac{\sigma^2}{2E}$  (d)  $\frac{E}{2\sigma^2}$   
 where  $\sigma$  = stress at the elastic limit.
27. If  $D$  is the diameter of a sphere, then volumetric strain is equal to  
 (a) two times the strain of diameter (b) 1.5 times the strain of diameter  
 (c) three times the strain of diameter (d) the strain of diameter.
28. If  $l$  be the length and  $D$  be the diameter of a cylindrical rod, then volumetric strain of the rod is equal to  
 (a) strain of length plus strain of diameter  
 (b) strain of diameter  
 (c) strain of length + twice the strain of diameter  
 (d) strain of length.
29. The extension per unit length of the rod due to suddenly applied load as compared to the same load gradually applied to the same rod is  
 (a) same (b) double  
 (c) three times (d) half.
30. The stress due to suddenly applied load as compared to the stress due to the same load gradually applied to the same rod is  
 (a) half (b) same  
 (c) double (d) three times.



31. The tensile force at a distance  $y$  from support in a vertical hanging bar of length  $l$  which carries a load  $P$  at the bottom is equal to  
 (a)  $P$  (b)  $P + wl$   
 (c)  $P + w(l - y)$  (d)  $P + wy$   
 where  $w$  = weight per unit length.
32. The normal stress on an oblique plane at an angle  $\theta$  to the cross-section of a body which is subjected to a direct tensile stress ( $\sigma$ ) is equal to  
 (a)  $\frac{\sigma}{2} \sin 2\theta$  (b)  $\sigma \cos \theta$   
 (c)  $\sigma \cos^2 \theta$  (d)  $\sigma \sin^2 \theta$ .
33. In question 32, the normal stress on the oblique plane will be maximum when  $\theta$  is equal to  
 (a)  $90^\circ$  (b)  $45^\circ$   
 (c)  $0^\circ$  (d)  $30^\circ$ .
34. The tangential or shear stress on an oblique plane at an angle  $\theta$  to the cross-section of a body which is subjected to a direct tensile stress ( $\sigma$ ) is equal to  
 (a)  $\frac{\sigma}{2} \sin 2\theta$  (b)  $\sigma \cos \theta$   
 (c)  $\sigma \cos^2 \theta$  (d)  $\sigma \sin^2 \theta$ .
35. In question 34, the tangential or shear stress on the oblique plane will be maximum when  $\theta$  is equal to  
 (a)  $90^\circ$  (b)  $45^\circ$   
 (c)  $0^\circ$  (d)  $30^\circ$ .
36. The resultant stress on an oblique plane at an angle  $\theta$  to the cross-section of a body which is subjected to a direct tensile stress is  
 (a)  $\sigma/2 \sin 2\theta$  (b)  $\sigma \cos \theta$   
 (c)  $\sigma \cos^2 \theta$  (d)  $\sigma \sin^2 \theta$ .
37. If a member is subjected to an axial tensile load, the plane normal to the axis of loading carries  
 (a) minimum normal stress (b) maximum normal stress  
 (c) maximum shear stress (d) none of the above.
38. If a member is subjected to an axial tensile load, the plane inclined at  $45^\circ$  to the axis of loading carries  
 (a) minimum shear stress (b) maximum normal stress  
 (c) maximum shear stress (d) none of the above.
39. The maximum shear stress induced in a member which is subjected to an axial load is equal to  
 (a) maximum normal stress (b) half of maximum normal stress  
 (c) twice the maximum normal stress (d) thrice the maximum normal stress.
40. If a member, whose tensile strength is more than two times the shear strength, is subjected to an axial load upto failure, the failure of the member will occur by  
 (a) maximum normal stress (b) maximum shear stress  
 (c) normal stress or shear stress (d) none of the above.

41. The elongation of a conical bar due to its own weight is equal to  
 (a)  $\frac{wl}{2E}$  (b)  $\frac{wl^2}{6E}$   
 (c)  $\frac{wl^3}{6E}$  (d)  $\frac{wl^4}{6E}$   
 where  $l$  = length of bar and  $w$  = weight per unit volume.
42. If a beam is fixed at both its ends, it is called a  
 (a) fixed beam (b) built-in beam  
 (c) encastered beam (d) any one of the above  
 (e) none of the above.
43. If a beam is supported on more than two supports, it is called a  
 (a) built-in beam (b) continuous beam  
 (c) simply supported beam (d) encastered beam.
44. Choose the wrong statement  
 (a) The shear force at any section of a beam is equal to the total sum of the forces acting on the beam on any one side of the section.  
 (b) The magnitude of the bending moment at any section of a beam is equal to the vector sum of the moments (about the section) due to the forces acting on the beam on any one side of the section.  
 (c) A diagram which shows the values of shear forces at various sections of structural member is called a shear force diagram.  
 (d) A simply supported beam is one which is supported on more than two supports.
45. A simply supported beam of span ( $l$ ) carries a point load ( $W$ ) at the centre of the beam. The bending moment diagram will be a  
 (a) parabola with maximum ordinate at the centre of the beam  
 (b) parabola with maximum ordinate at one end of the beam  
 (c) triangle with maximum ordinate at the centre of the beam  
 (d) triangle with maximum ordinate at one end of the beam.
46. A simply supported beam of span ( $l$ ) carries a uniformly distributed load ( $w$  N per unit length) over the whole span. The bending moment diagram will be a  
 (a) parabola with maximum ordinate at the centre of the beam  
 (b) parabola with maximum ordinate at one end of the beam  
 (c) triangle with maximum ordinate at the centre of the span  
 (d) triangle with maximum ordinate at one end of the beam.
47. A cantilever of length ( $l$ ) carries a point load ( $W$ ) at the free end. The bending moment diagram will be a  
 (a) parabola with maximum ordinate at the centre of the beam  
 (b) parabola with maximum ordinate at the cantilever end  
 (c) triangle with maximum ordinate at the free end  
 (d) triangle with maximum ordinate at the cantilever end.

48. A cantilever of length ( $l$ ) carries a uniformly distributed load over the whole length. The bending moment diagram will be  
 (a) parabola with maximum ordinate at the centre  
 (b) parabola with maximum ordinate at the cantilever end  
 (c) triangle with maximum ordinate at the free end  
 (d) triangle with maximum ordinate at the cantilever end.
49. A simply supported beam of span ( $l$ ) carries a point load ( $W$ ) at the centre of the beam. The shear force diagram will be  
 (a) a rectangle (b) a triangle  
 (c) two equal and opposite rectangles (d) two equal and opposite triangles.
50. A simply supported beam of span ( $l$ ) carries a uniformly distributed load over the whole span. The shear force diagram will be  
 (a) a rectangle (b) a triangle  
 (c) two equal and opposite rectangles (d) two equal and opposite triangles.
51. A cantilever of length ( $l$ ) carries a point load ( $W$ ) at the free end. The shear force diagram will be  
 (a) two equal and opposite rectangles (b) a rectangle  
 (c) two equal and opposite triangles (d) a triangle.
52. A cantilever of length ( $l$ ) carries a uniformly distributed load over the whole length. The shear force diagram will be  
 (a) two equal and opposite rectangles (b) a rectangle  
 (c) two equal and opposite triangles (d) a triangle.
53. The bending moment on a section is maximum where shearing force is  
 (a) minimum (b) maximum  
 (c) zero (d) equal  
 (e) changing sign (f) none of the above.
54. The point of zero bending moment, where the continuous curve of bending moment changes sign, is called  
 (a) the point of contra-flexure (b) the point of inflation  
 (c) the point of virtual hinge (d) all of the above.
55. The point of contra-flexure occurs only in  
 (a) continuous beams (b) cantilever beams  
 (c) overhanging beams (d) simply supported beams  
 (e) all of the above (f) none of the above.
56. The bending moment at a section, where shear force is zero, will be  
 (a) zero (b) maximum  
 (c) minimum (d) either minimum or maximum  
 (e) none of the above.
57. A beam of uniform strength is one which has same  
 (a) bending stress at every section (b) deflection throughout the beam  
 (c) bending moment throughout the beam (d) shear force throughout the beam.

58. The shear force and bending moment are zero at the free end of a cantilever, if it carries a  
 (a) point load at the free end  
 (b) uniformly distributed load over the whole length  
 (c) point load in the middle of its length  
 (d) none of the above.
59. A simply supported beam carries a uniformly distributed load of  $w$  N per unit length over the whole span ( $l$ ). The shear force at the centre is  
 (a)  $\frac{wl}{2}$  (b)  $\frac{wl^2}{8}$   
 (c)  $\frac{wl}{4}$  (d) zero.
60. For the question 59, the shear force at the supported ends will be  
 (a)  $\pm \frac{wl}{2}$  (b)  $\frac{wl^2}{8}$   
 (c)  $\frac{wl}{4}$  (d) zero.
61. For the question 59, the bending moment at the supported ends will be  
 (a)  $\pm \frac{wl}{2}$  (b)  $\frac{wl^2}{8}$   
 (c)  $\frac{wl}{4}$  (d) zero.
62. For the question 59, the bending moment at the centre will be  
 (a)  $\pm \frac{wl}{2}$  (b)  $\frac{wl^2}{8}$   
 (c)  $\frac{wl}{4}$  (d) zero.
63. For the question 59, the point of contra-flexure is at  
 (a) the supported end (b) the middle of the beam  
 (c) a distance  $\frac{l}{4}$  from the supported ends (d) none of the above.
64. A cantilever of length ( $l$ ) carries a uniformly distributed load  $w$  N per unit length for the whole length. The shear force at the free end will be  
 (a)  $wl$  (b)  $\frac{wl^2}{2}$   
 (c)  $\frac{wl}{2}$  (d) zero.
65. In question 64, the shear force at the fixed end will be  
 (a)  $wl$  (b)  $\frac{wl^2}{2}$   
 (c)  $\frac{wl}{2}$  (d) zero.

66. In a tensile test of a specimen, the ratio of maximum load to the original cross-sectional area of the test piece is called  
 (a) yield stress (b) ultimate stress  
 (c) safe stress (d) breaking stress.
67. A short column of rectangular section carries a vertical point load  $W$  axially. The stress on the section of the column will be  
 (a) uniform  
 (b) zero at one end and maximum at the other end  
 (c) zero at the axis and maximum on the outer ends  
 (d) tensile on one end and compressive on the other.
68. If in question 67, the short column carries a vertical point load eccentrically, then the stress on the section will be  
 (a) uniform  
 (b) zero at the axis and maximum on the outer ends  
 (c) zero at one end and maximum at the other end  
 (d) tensile on one end and compressive on the other  
 (e) non-uniform and will depend upon the amount of eccentricity.
69. A solid circular shaft of diameter  $D$  carries an axial load  $W$ . If the same load is applied axially on a hollow circular shaft of inner diameter as  $\frac{D}{2}$ , the ratio of stresses in a solid shaft to that of hollow shaft would be  
 (a)  $\frac{1}{2}$  (b)  $\frac{1}{4}$   
 (c)  $\frac{4}{3}$  (d)  $\frac{3}{4}$
70. If in question 69, the inner diameter of hollow shaft in  $D/3$ , then the ratio of stress in a solid shaft to that of hollow shaft would be  
 (a)  $\frac{1}{2}$  (b)  $\frac{1}{4}$   
 (c)  $\frac{8}{9}$  (d)  $\frac{9}{8}$
71. Under tensile test, a test piece of a material is having 40% elongation whereas another test piece of the same dimensions but of different material is having 25% elongation. Then the ductility of the first material as compared to that of second material is  
 (a) less (b) same  
 (c) more (d) none of the above.
72. The diameter of a cast iron round bar, on which tensile test is performed, at fracture will  
 (a) increase (b) decrease  
 (c) be approximately same (d) none of the above.
73. The diameter of a mild steel round bar, on which tensile test is performed, at fracture will  
 (a) increase (b) decrease  
 (c) be same (d) none of the above.

74. If a member is subjected to a uniform bending moment ( $M$ ), the radius of curvature of the deflected form of the member is given by  
 (a)  $\frac{M}{R} = \frac{E}{I}$  (b)  $\frac{M}{I} = \frac{E}{R}$   
 (c)  $\frac{M}{I} = \frac{R}{E}$  (d)  $\frac{M}{E} = RI$
75. Which one of the following equations is correct  
 (a)  $\frac{1}{R} = \frac{d^2 y}{dx^2} = \frac{EI}{M}$  (b)  $\frac{1}{R} = \frac{d^2 y}{dx^2} = \frac{M}{EI}$   
 (c)  $R = \frac{d^2 y}{dx^2} = \frac{M}{EI}$  (d)  $R = \frac{d^2 y}{dx^2} = \frac{EI}{M}$   
 where  $R$  = radius of curvature and  $M$  = bending moment.
76. The expression  $EI \frac{d^2 y}{dx^2}$  at a section of a member represents  
 (a) shearing force (b) rate of loading  
 (c) bending moment (d) slope.
77. The expression  $EI \frac{d^3 y}{dx^3}$  at a section of a member represents  
 (a) shearing force (b) rate of loading  
 (c) bending moment (d) slope.
78. The expression  $EI \frac{d^4 y}{dx^4}$  at a section of a member represents  
 (a) shearing force (b) rate of loading  
 (c) bending moment (d) slope.
79. A cantilever of length ( $l$ ) carries a point load ( $W$ ) at the free end. The downward deflection at the free end is equal to  
 (a)  $\frac{Wl^3}{8EI}$  (b)  $\frac{Wl^3}{3EI}$   
 (c)  $\frac{5Wl^3}{384EI}$  (d)  $\frac{Wl^3}{48EI}$
80. In question 79, the slope at the free end will be  
 (a)  $\frac{Wl^2}{6EI}$  (b)  $\frac{Wl^2}{2EI}$   
 (c)  $\frac{Wl^2}{24EI}$  (d)  $\frac{Wl^2}{16EI}$
81. A cantilever of length ( $l$ ) carries a uniformly distributed load  $w$  per unit length over the whole length. The downward deflection at the free end will be  
 (a)  $\frac{Wl^3}{8EI}$  (b)  $\frac{Wl^3}{3EI}$   
 (c)  $\frac{5Wl^3}{384EI}$  (d)  $\frac{Wl^3}{48EI}$   
 where  $W = w \times l$  = total load.

82. In question 81, the slope at the free end will be

- (a)  $\frac{Wl^2}{6EI}$  (b)  $\frac{Wl^2}{2EI}$   
 (c)  $\frac{Wl^2}{24EI}$  (d)  $\frac{Wl^2}{16EI}$

where  $W = \text{total load} = w \times l$ .

83. A uniform simply supported beam of span ( $l$ ) carries a point load ( $W$ ) at the centre. The downward deflection at the centre will be

- (a)  $\frac{Wl^3}{8EI}$  (b)  $\frac{Wl^3}{3EI}$   
 (c)  $\frac{5Wl^3}{384EI}$  (d)  $\frac{Wl^3}{48EI}$

84. In question 83, the slope at the support will be

- (a)  $\frac{Wl^2}{6EI}$  (b)  $\frac{Wl^2}{2EI}$   
 (c)  $\frac{Wl^2}{24EI}$  (d)  $\frac{Wl^2}{16EI}$

85. A uniformly simply supported beam of span ( $l$ ) carries a uniformly distributed load  $w$  per unit length over the whole span. The downward deflection at the centre will be

- (a)  $\frac{Wl^3}{8EI}$  (b)  $\frac{Wl^3}{3EI}$   
 (c)  $\frac{5Wl^3}{384EI}$  (d)  $\frac{Wl^3}{48EI}$

where  $W = w \times l = \text{total load}$ .

86. A simply supported beam is of rectangular section. It carries a uniformly distributed load over the whole span. The deflection at the centre is  $y$ . If the depth of the beam is doubled, the deflection at the centre would be

- (a)  $2y$  (b)  $4y$   
 (c)  $\frac{y}{2}$  (d)  $\frac{y}{8}$

87. A simply supported beam carries a uniformly distributed load over the whole span. The deflection at the centre is  $y$ . If the distributed load per unit length is doubled and also depth of the beam is doubled, then the deflection at the centre would be

- (a)  $2y$  (b)  $4y$   
 (c)  $\frac{y}{2}$  (d)  $\frac{y}{4}$

88. The slope at the free end of a cantilever of length 1 m is  $1^\circ$ . If the cantilever carries uniformly distributed load over the whole length, then the deflection at the free end will be

- (a) 1 cm (b) 1.309 cm  
 (c) 2.618 cm (d) 3.927 cm.

89. A cantilever of length ( $l$ ) carries a point load ( $W$ ) at a distance  $x$  from the fixed end, then the deflection at the free end will be

- (a)  $\frac{Wx^3}{3EI} + \frac{Wx^2}{2EI} \times l$  (b)  $\frac{Wl^3}{3EI}$   
 (c)  $\frac{Wx^3}{3EI} + \frac{Wx^2}{2EI} (l-x)$  (d)  $\frac{Wx^2}{2EI} + \frac{Wx^3}{3EI} (l-x)$

90. A cantilever of length ( $l$ ) carries a uniformly distributed load of  $w$  per unit length for a distance  $x$  from the fixed end, then the deflection at the free end will be

- (a)  $\frac{Wx^4}{8EI} + \frac{Wx^3}{6EI} \times l$  (b)  $\frac{Wx^4}{8EI}$   
 (c)  $\frac{Wl^4}{8EI}$  (d)  $\frac{Wx^4}{8EI} + \frac{Wx^3}{6EI} \times (l-x)$

91. A cantilever of length ( $l$ ) carries a distributed load whose intensity varies from zero at the free end to  $w$  per unit length at the fixed end. The deflection at the free end will be

- (a)  $\frac{wl^4}{3EI}$  (b)  $\frac{wl^4}{8EI}$   
 (c)  $\frac{11}{120} \frac{wl^4}{EI}$  (d)  $\frac{wl^4}{30EI}$

92. A cantilever of length ( $l$ ) carries a distributed load whose intensity varies uniformly from zero at the fixed end to  $w$  per unit length at the free end. The deflection at the free end will be

- (a)  $\frac{wl^4}{3EI}$  (b)  $\frac{wl^4}{8EI}$   
 (c)  $\frac{11}{120} \frac{wl^4}{EI}$  (d)  $\frac{wl^4}{30EI}$

93. The statement that 'the deflection at any point in a beam subjected to any load system is equal to the partial derivative of the total strain energy stored with respect to the load acting at the point in the direction in which deflection is desired' is called

- (a) Bettle's law (b) the first theorem of Castigliano  
 (c) Clapeyron's theorem (d) Maxwell's law.

94. A laminated spring 1 m long carries a central point load of 2000 N. The spring is made up of plates each 5 cm wide and 1 cm thick. The bending stress in the plates is limited to  $10 \text{ N/mm}^2$ . The number of plates required, will be

- (a) 3 (b) 5  
 (c) 6 (d) 8.

95. In question 94, if  $E = 2 \times 10^5 \text{ N/mm}^2$  the deflection under the given load of 2000 N will be

- (a) 1 cm (b) 1.25 cm  
 (c) 1.3 cm (d) 1.40 cm.

96. A fixed beam is a beam whose end supports are such that the end slopes

- (a) are maximum (b) are minimum  
 (c) are zero (d) none of the above.

97. A fixed beam of length ( $l$ ) carries a point load ( $W$ ) at the centre. The deflection at the centre is  
 (a) same as for a simply supported beam  
 (b) half of the deflection for a simply supported beam  
 (c) one-fourth of the deflection for a simply supported beam  
 (d) double the deflection for a simply supported beam.
98. For the question 97, the number of points of contra-flexure  
 (a) is one (b) are two  
 (c) are three (d) is none.
99. For the question 97, the points of contra-flexure lies at  
 (a) the fixed ends (b) the middle of the beam  
 (c)  $\frac{l}{4}$  from the ends (d) none of the above.
100. For the question 97, the bending moment at the centre is  
 (a) same as for a simply supported beam  
 (b) half of the bending moment for a simply supported beam  
 (c) one-fourth of the bending moment for a simply supported beam  
 (d) double the bending moment for a simply supported beam.
101. For the question 97, the bending moment at the fixed ends is  
 (a) zero (b)  $\frac{WL}{4}$   
 (c)  $\frac{WL}{8}$  (d)  $\frac{WL}{2}$ .
102. A fixed beam of span ( $l$ ) carries a uniformly distributed load of  $w$  per unit length over the whole span. The deflection at the centre is  
 (a) equal of the central deflection of a simply supported beam  
 (b) half of the central deflection for a simply supported beam  
 (c) one-fourth of the central deflection for a simply supported beam  
 (d) one-fifth of the central deflection of the simply supported beam.
103. For the question 102, the points of contra-flexure lies at  
 (a) the fixed ends (b) the middle of the beam  
 (c)  $\frac{l}{4}$  from the ends (d)  $\frac{l}{2\sqrt{3}}$  from the centre of the span.
104. For the solution of problems on fixed beam, the condition is  
 (a) area of free B.M. diagram = area of fixed B.M. diagram  
 (b) the distance of the centroid of the free B.M. diagram from an end should be equal to the distance of the centroid of fixed B.M. diagram from the same end  
 (c) both (a) and (b) (d) none of the above.
105. In question 102, the end moments are each equal to  
 (a)  $\frac{wl^2}{8}$  (b)  $\frac{wl^2}{6}$   
 (c)  $\frac{wl^2}{12}$  (d)  $\frac{wl^2}{4}$ .

106. The load on a circular column of diameter ( $d$ ) for keeping the stress wholly compressive may be applied anywhere within a concentric circle of diameter  
 (a)  $\frac{d}{8}$  (b)  $\frac{d}{4}$   
 (c)  $\frac{d}{3}$  (d)  $\frac{d}{2}$ .
107. Three beams of circular, square, rectangular (with depth twice the width) sections and of same length are subjected to the same maximum bending moment. If allowable stress is the same then the section which will require maximum weight of the same material will be  
 (a) rectangular (b) square  
 (c) circular (d) none of the above.
108. For the question 107, the section which will require minimum weight of the same material will be  
 (a) rectangular (b) square  
 (c) circular (d) none of the above.
109. For the question 107, the ratios of weight of circular beam, weight of rectangular beam and weight of square beam is  
 (a) 1 : 0.7938 : 1.118 (b) 0.7938 : 1 : 1.118  
 (c) 1.118 : 0.7938 : 1 (d) 0.7938 : 1.118 : 1.
110. Kernel or core of a section is the figure within which load may be placed so as  
 (a) to produce tensile stress at one end and compressive stress at the other end  
 (b) to produce tensile stress at both the ends of the section  
 (c) to produce tensile stress in the middle of the section  
 (d) not to produce tensile stress anywhere in the section.
111. The ratio of moment of inertia about the neutral axis to the distance of the most distance point of the section from the neutral axis is called  
 (a) moment of inertia (b) section modulus  
 (c) polar moment of inertia (d) modulus of rigidity.
112. The relation between maximum stress ( $\sigma$ ) offered by a section, moment of resistance ( $M$ ) and section modulus ( $Z$ ) is given by  
 (a)  $M = \frac{\sigma}{Z}$  (b)  $M = \frac{Z}{\sigma}$   
 (c)  $M = \sigma \times Z$  (d)  $M = \frac{1}{\sigma \times Z}$ .
113. Choose the correct statement  
 (a) Section modulus of a hollow circular section of external diameter  $D$  and internal diameter  $d$  is equal to  $\frac{\pi(D^4 - d^4)}{64D}$ .  
 (b) Section modulus of a circular section of diameter  $D$  is  $\frac{\pi D^4}{32}$ .

- (c) Section modulus of a rectangular section is  $\frac{bd^2}{6}$ .
- (d) Section modulus of a square section  $b \times b$  is  $\frac{b^4}{12}$ .
114. A beam of uniform strength can be designed by  
 (a) varying the depth of the beam but maintaining constant width  
 (b) varying the width of the beam but maintaining constant depth  
 (c) varying width and depth (d) any one of the above  
 (e) none of the above.
115. For a beam of uniform strength having constant depth, the width at a distance  $x$  from the support varies with  
 (a)  $\sqrt{x}$  (b)  $x$   
 (c)  $x^{1/4}$  (d)  $x^{3/4}$ .
116. For a beam of uniform strength having constant width, the depth of the beam at a distance  $x$  from the support varies with  
 (a)  $\sqrt{x}$  (b)  $x$   
 (c)  $x^{1/4}$  (d)  $x^{3/4}$ .
117. Flitched beam means a  
 (a) continuous beam (b) fixed beam  
 (c) beam of composite section consisting of a wooden beam strengthened by mild steel plates (d) none of the above.
118. The shear stress required to cause plastic deformation of solid metal is called  
 (a) proof stress (b) flow stress  
 (c) rupture stress (d) ultimate stress.
119. The stress which will cause a specified permanent deformation in a material (usually 0.01% or less) is called  
 (a) proof stress (b) flow stress  
 (c) rupture stress (d) ultimate stress.
120. The stress obtained by dividing the load at the moment of incipient fracture, by the area supporting that load is called  
 (a) proof stress (b) flow stress  
 (c) rupture stress (d) ultimate stress.
121. The statement that 'If unit loads rest upon a beam at the two points A and B, then the deflection at A due to unit load at B is equal to the deflection at B due to unit load at A' is given by  
 (a) Mohr (b) Castigliano  
 (c) Maxwell (d) Rankine.
122. A short column of rectangular section carries a point load (W) acting with an eccentricity (e). The shape of Kernel area would be  
 (a) square (b) rectangle  
 (c) circle (d) rhombus.

123. If in question 122, the column is of circular section then the shape of Kernel area would be  
 (a) square (b) rectangle  
 (c) circle (d) rhombus.
124. Every cross-section of a shaft, which is subjected to a twisting moment, is under  
 (a) compressive stress (b) shear stress  
 (c) tensile stress (d) bending stress.
125. The shear stress at any point of a shaft, subjected to twisting moment, is  
 (a) proportional to its distance from the central axis of the shaft  
 (b) inversely proportional to its distance from the central axis of the shaft  
 (c) proportional to the square of its distance from the central axis of the shaft  
 (d) none of the above.
126. When a shaft is subjected to torsion, the relation between maximum shear stress ( $\tau$ ), modulus of rigidity of the shaft (C) and angle of twist ( $\theta$ ) is given by  
 (a)  $\frac{C\theta}{\tau} = \frac{R}{L}$  (b)  $\frac{C\theta}{L} = \frac{\tau}{R}$   
 (c)  $\frac{C\theta}{R} = \frac{\tau}{L}$  (d)  $\frac{C}{L\theta} = \frac{\tau}{R}$   
 where  $L$  = length of shaft and  $R$  = radius of shaft.
127. A solid shaft of diameter  $D$  transmits the torque equal to  
 (a)  $\frac{\pi}{32} \tau D^3$  (b)  $\frac{\pi}{64} \tau D^3$   
 (c)  $\frac{\pi}{16} \tau D^3$  (d)  $\frac{\pi}{8} \tau D^3$   
 where  $\tau$  = maximum allowable shear stress.
128. The torque transmitted by a hollow shaft of external diameter ( $D$ ) and internal diameter ( $d$ ) is equal to  
 (a)  $\frac{\pi}{32} \tau [D^3 - d^3]$  (b)  $\frac{\pi}{16} \tau [D^3 - d^3]$   
 (c)  $\frac{\pi}{16} \tau \left[ \frac{D^4 - d^4}{D} \right]$  (d)  $\frac{\pi}{32} \tau \left[ \frac{D^4 - d^4}{D} \right]$ .
129. Polar moment of inertia of a solid circular shaft of diameter  $D$  is equal to  
 (a)  $\frac{\pi D^3}{32}$  (b)  $\frac{\pi D^4}{32}$   
 (c)  $\frac{\pi D^3}{64}$  (d)  $\frac{\pi D^4}{64}$ .
130. Polar moment of inertia of a hollow circular shaft is equal to  
 (a)  $\frac{\pi}{32} [D^3 - d^3]$  (b)  $\frac{\pi}{32} [D^4 - d^4]$   
 (c)  $\frac{\pi}{64} [D^3 - d^3]$  (d)  $\frac{\pi}{64} [D^4 - d^4]$ .

131. Torsional rigidity of a shaft is equal to  
 (a) product of modulus of rigidity and polar moment of inertia  
 (b) sum of modulus of rigidity and polar moment of inertia  
 (c) difference of modulus of rigidity and polar moment of inertia  
 (d) ratio of modulus of rigidity and polar moment of inertia.
132. Polar modulus of a shaft section is equal to  
 (a) product of polar moment of inertia and maximum radius of the shaft  
 (b) ratio of polar moment of inertia to maximum radius of the shaft  
 (c) sum of polar moment of inertia and maximum radius of the shaft  
 (d) difference of polar moment of inertia and maximum radius of the shaft.
133. The torsional rigidity of a shaft is defined as the torque required to produce  
 (a) maximum twist in the shaft (b) maximum shear stress in the shaft  
 (c) minimum twist in the shaft  
 (d) a twist of one radian per unit length of the shaft.
134. The flexural rigidity for the deflection of beams is expressed as  
 (a)  $\frac{I}{E}$  (b)  $\frac{E}{I}$   
 (c)  $EI$  (d)  $\frac{1}{EI}$
- where  $E$  = modulus of elasticity and  $I$  = moment of inertia.
135. The greatest twisting moment which a given shaft section can resist is equal to  
 (a) polar modulus  $\times f$  (b) polar modulus/ $\tau$   
 (c)  $\sqrt[3]{\text{polar modulus}}$  (d) none of the above.
136. Choose the correct statement  
 (a) Shafts of the same material and length having the same polar modulus have the same strength.  
 (b) For a shaft of a given material, the magnitude of polar modulus is a measure of its strength in resisting torsion.  
 (c) From a number of shafts of the same length and material, the shaft with greatest polar modulus will resist the maximum twisting moment.  
 (d) all of the above. (e) none of the above.
137. Two shafts, one solid and the other hollow, are made of the same materials and are having same length and weight. The hollow shaft as compared to solid shaft is  
 (a) more strong (b) less strong  
 (c) having same strength (d) none of the above.
138. Two shafts, one solid and the other hollow, are of same length and material. They are subjected to the same torque and attain the same permissible maximum shear stress at the same time. The weight of hollow shaft will be  
 (a) more (b) less  
 (c) same as of solid shaft (d) none of the above.
139. The torque transmitted, by a solid shaft of diameter 40 mm if the shear stress is not to exceed  $400 \text{ N/cm}^2$ , would be  
 (a)  $1.6 \times \pi \text{ N-m}$  (b)  $16\pi \text{ N-m}$   
 (c)  $0.8 \times \pi \text{ N-m}$  (d)  $0.4 \times \pi \text{ N-m}$ .

140. If in question 139, the diameter of the solid shaft is doubled, then torque transmitted would be  
 (a) same (b) double  
 (c) four times (d) eight times.
141. If in question 139, the diameter of the solid shaft is made 20 mm, then torque transmitted would be  
 (a) same (b) one-half  
 (c) one-eighth (d) one-fourth.
142. The torsion equation is given by  
 (a)  $\frac{T}{J} = \frac{\tau}{R} = \frac{L}{C\theta}$  (b)  $\frac{T}{R} = \frac{\tau}{J} = \frac{C\theta}{L}$   
 (c)  $\frac{T}{J} = \frac{\tau}{R} = \frac{C\theta}{L}$  (d)  $\frac{T}{\tau} = \frac{R}{J} = \frac{C\theta}{L}$ .
143. The assumption made, while determining the shear stress in a circular shaft subjected to torsion, is that  
 (a) the material of the shaft is uniform (b) the twist along the shaft is uniform  
 (c) cross-sections of the shaft is plane and circular before and after the twist  
 (d) all of the above (e) none of the above.
144. When a shaft of diameter ( $d$ ) is subjected to combined twisting moment ( $T$ ) and bending moment ( $M$ ), the maximum shear stress ( $\tau$ ) is equal to  
 (a)  $\frac{R}{J} \sqrt{M^2 + T^2}$  (b)  $\frac{J}{R} \sqrt{M^2 + T^2}$   
 (c)  $\frac{R}{J} (M^2 + T^2)$  (d)  $\frac{J}{R} (M^2 + T^2)$
- where  $J$  = polar moment of inertia of the shaft.
145. In question 144, the maximum normal stress is given by  
 (a)  $\frac{16}{\pi d^3} (M - \sqrt{M^2 + T^2})$  (b)  $\frac{16}{\pi d^3} (M + \sqrt{M^2 + T^2})$   
 (c)  $\frac{16}{\pi d^3} (M - \sqrt{M^2 - T^2})$  (d)  $\frac{16}{\pi d^3} (M + \sqrt{M^2 - T^2})$ .
146. A cylindrical vessel is said to be thin if the ratio of its internal diameter to the wall thickness is  
 (a) less than 20 (b) equal to 20  
 (c) more than 20 (d) none of the above.
147. The hoop or circumferential stress in a thin cylindrical shell of diameter ( $D$ ), length ( $L$ ) and thickness ( $t$ ), when subjected to an internal pressure ( $p$ ) is equal to  
 (a)  $\frac{pD}{4t}$  (b)  $\frac{pD}{2t}$   
 (c)  $\frac{2pD}{t}$  (d)  $\frac{4pD}{t}$ .
148. The longitudinal or axial stress in a thin cylindrical shell of diameter ( $D$ ), length ( $L$ ) and thickness ( $t$ ), when subjected to an internal pressure ( $p$ ) is equal to

- (a)  $\frac{pD}{4t}$  (b)  $\frac{pD}{2t}$   
 (c)  $\frac{2pD}{t}$  (d)  $\frac{4pD}{t}$
149. The maximum shear stress in a thin cylindrical shell, when subjected to an internal pressure ( $p$ ) is equal to  
 (a)  $\frac{pD}{4t}$  (b)  $\frac{pD}{8t}$   
 (c)  $\frac{pD}{2t}$  (d)  $\frac{pD}{t}$
150. The maximum shear stress in a thin spherical shell, when subjected to an internal pressure ( $p$ ) is equal to  
 (a)  $\frac{pD}{4t}$  (b)  $\frac{pD}{8t}$   
 (c)  $\frac{pD}{2t}$  (d) zero.
151. The hoop or circumferential stress in a thin spherical shell, when subjected to an internal pressure ( $p$ ) is equal to  
 (a)  $\frac{pD}{4t}$  (b)  $\frac{pD}{2t}$   
 (c)  $\frac{pD}{8t}$  (d)  $\frac{2pD}{t}$
152. The hoop or circumferential stress in a riveted cylindrical shell, when subjected to an internal pressure ( $p$ ) is equal to  
 (a)  $\frac{pD}{4t \eta_l}$  (b)  $\frac{pD}{4t \eta_c}$   
 (c)  $\frac{pD}{2t \eta_l}$  (d)  $\frac{pD}{2t \eta_c}$
- where  $D$  = internal diameter,  $\eta_l$  = efficiency of longitudinal joint and  $\eta_c$  = efficiency of circumferential joint.
153. The longitudinal stress in a riveted cylindrical shell, when subjected to internal pressure ( $p$ ) is equal to  
 (a)  $\frac{pD}{4t \eta_l}$  (b)  $\frac{pD}{4t \eta_c}$   
 (c)  $\frac{pD}{2t \eta_l}$  (d)  $\frac{pD}{2t \eta_c}$
- where  $\eta_l$  = efficiency of longitudinal joint and  $\eta_c$  = efficiency of circumferential joint.
154. Choose the correct statement.  
 (a) The hoop stress in a thin cylindrical shell is compressive stress.  
 (b) The shear stress in a thin spherical shell is more than that of in a thin cylindrical shell.

- (c) The design of thin cylindrical shell is based on hoop stress.  
 (d) The ratio of hoop stress to longitudinal stress for a thin cylindrical shell is 1/2.
155. A water main 1 m in diameter contains a fluid having pressure 1 N/mm<sup>2</sup>. If the maximum permissible tensile stress in the metal is 20 N/mm<sup>2</sup>, the thickness of the metal required would be  
 (a) 2 cm (b) 2.5 cm  
 (c) 1 cm (d) 0.5 cm.
156. The circumferential strain in case of thin cylindrical shell, when subjected to internal pressure ( $p$ ), is equal to  
 (a)  $\frac{pd}{2tE} \left(1 - \frac{1}{m}\right)$  (b)  $\frac{pd}{2tE} \left(1 - \frac{1}{2m}\right)$   
 (c)  $\frac{pd}{4tE} \left(1 - \frac{1}{m}\right)$  (d)  $\frac{3pd}{4tE} \left(1 - \frac{1}{m}\right)$
157. The longitudinal strain in case of thin cylindrical shell, when subjected to internal pressure ( $p$ ), is equal to  
 (a)  $\frac{pd}{2tE} \left(\frac{1}{2} - \frac{1}{m}\right)$  (b)  $\frac{pd}{2tE} \left(1 - \frac{1}{2m}\right)$   
 (c)  $\frac{pd}{4tE} \left(1 - \frac{1}{m}\right)$  (d)  $\frac{3pd}{4tE} \left(1 - \frac{1}{m}\right)$
158. The strain in any direction in case of a thin spherical shell, when subjected to internal pressure ( $p$ ), is equal to  
 (a)  $\frac{pd}{2tE} \left(\frac{1}{2} - \frac{1}{m}\right)$  (b)  $\frac{pd}{2tE} \left(1 - \frac{1}{2m}\right)$   
 (c)  $\frac{pd}{4tE} \left(1 - \frac{1}{m}\right)$  (d)  $\frac{3pd}{4tE} \left(1 - \frac{1}{m}\right)$
159. The volumetric strain in case of thin spherical shell, when subjected to internal pressure ( $p$ ), is equal to  
 (a)  $\frac{pd}{2tE} \left(\frac{1}{2} - \frac{1}{m}\right)$  (b)  $\frac{pd}{2tE} \left(1 - \frac{1}{2m}\right)$   
 (c)  $\frac{pd}{4tE} \left(1 - \frac{1}{m}\right)$  (d)  $\frac{3pd}{4tE} \left(1 - \frac{1}{m}\right)$
160. The circumferential strain in case of thin cylindrical shell, when subjected to internal pressure ( $p$ ), is  
 (a) more than diametral strain (b) less than diametral strain  
 (c) equal to diametral strain (d) none of the above.
161. In the assembly of pulley, key and shaft  
 (a) key is made strongest link  
 (b) key is made weaker link  
 (c) all the three are designed for the same strength  
 (d) pulley is made weaker.



162. A coil is having stiffness  $k$ . It is cut into two halves, then the stiffness of the cut coils will be  
 (a) same (b) half  
 (c) double (d) one-fourth.
163. The hoop stress in case of thick cylinders across the thickness  
 (a) is uniformly distributed  
 (b) varies from maximum at the outer circumference to minimum at inner circumference  
 (c) varies from maximum at the inner circumference to minimum at outer circumference  
 (d) is zero.
164. The longitudinal stress in case of thick cylinders  
 (a) is uniformly distributed  
 (b) varies from maximum at the outer circumference to minimum at inner circumference  
 (c) varies from maximum at the inner circumference to minimum at outer circumference  
 (d) none of the above.
165. In case of thick cylinders, at any point the three principal stresses, i.e., radial, circumferential and longitudinal  
 (a) are all tensile stress (b) are all compressive stresses  
 (c) are all shear stresses (d) none of the above.
166. In case of cylinders which have to carry high internal fluid pressure, the method adopted is to  
 (a) wind strong steel wire under tension on the cylinder  
 (b) shrink one cylinder over the other (c) both (a) and (b)  
 (d) none of the above.
167. The radial stress, at any radius  $x$  in case of a thick spherical shell subjected to internal fluid pressure  $p$ , is equal to  
 (a)  $\left(\frac{2b}{x^3}\right) - a$  (b)  $\left(\frac{b}{x^3}\right) + a$   
 (c)  $\left(\frac{x^3}{2b}\right) - a$  (d)  $\left(\frac{x^3}{b}\right) + a$   
 where  $a$  and  $b$  are constants.
168. The circumferential stress, at any radius  $x$  in case of a thick spherical shell subjected to internal fluid pressure  $p$ , is equal to  
 (a)  $\left(\frac{2b}{x^3}\right) - a$  (b)  $\frac{b}{x^3} + a$   
 (c)  $\left(\frac{x^3}{2b}\right) - a$  (d)  $\left(\frac{x^3}{b}\right) + a$ .
169. Choose the correct statement.  
 (a) When a thick cylinder is subjected to internal fluid pressure, the circumferential stress is maximum at the outer surface of the cylinder.  
 (b) In case of thick cylinders, the difference of circumferential stress and radial stress is constant.

- (c) In case of thick cylinders, the minimum value of radial stress is equal to internal fluid pressure.  
 (d) The single thick cylinder withstands high internal fluid pressure as compared to compound cylinder.
170. When a thick cylinder is subjected to internal fluid pressure ( $p_i$ ), the maximum value of circumferential stress is  
 (a)  $\frac{2p_i R_i^2}{R_o^2 - R_i^2}$  (b)  $p_i$   
 (c)  $O$  (d)  $\left(\frac{R_o^2 + R_i^2}{R_o^2 - R_i^2}\right) \times p_i$ .
171. The shearing strength per pitch length in case of butt joint is equal to  
 (a)  $n \times \frac{\pi}{4} d^2 \times \tau$  (b)  $2n \times \frac{\pi}{4} d^2 \times \tau$   
 (c)  $3n \times \frac{\pi}{4} d^2 \times \tau$  (d)  $4n \times \frac{\pi}{4} d^2 \times \tau$   
 where  $n$  = number of rivets per pitch length  
 $\tau$  = shear stress.
172. The tearing strength per pitch length of a riveted joint is equal to  
 (a)  $(p - d) \times t \times \sigma_c$  (b)  $(p - d) \times t \times \sigma_t$   
 (c)  $(p - d) \times t \times \tau$  (d)  $(p - 2d) \times t \times \sigma_t$   
 where  $p$  = pitch  
 $d$  = diameter of rivet  
 $t$  = thickness of plates and  
 $\sigma_c, \sigma_t$  and  $\tau$  = safe crushing, tensile and shear stresses respectively.
173. The bearing or crushing strength per pitch length of a riveted joint is equal to  
 (a)  $\frac{\pi}{4} d^2 \times \sigma_c \times n$  (b)  $\pi d \times t \times \sigma_c \times n$   
 (c)  $d \times t \times \sigma_c \times n$  (d)  $p \times t \times \sigma_c \times n$   
 where  $n$  = number of rivets per pitch length  
 $\sigma_c$  = safe crushing stress.
174. In case of riveted joint 'margin' is the distance between the  
 (a) centres of two consecutive rivets in a row  
 (b) centre of rivet hole to the nearest edge of plate  
 (c) centres of rivets in adjacent rows  
 (d) none of the above.
175. If the margin in case of riveted joint is at least  $1.5d$ , there will be  
 (a) tearing off the plate between the rivet hole and edge of the plate  
 (b) tearing off the plates between rivets  
 (c) no tearing off the plate between the rivet hole and edge of the plate  
 (d) no crushing of the joint.

76. The expression  $p \times t \times \sigma_t$  in case of a riveted joint is called  
 (a) tearing strength (b) bearing strength  
 (c) crushing strength (d) strength of solid plate.
177. If  $P_t$ ,  $P_s$  and  $P_c$  are the maximum load per pitch length for a riveted joint from tearing, shearing and crushing considerations respectively, then efficiency of the joint is equal to  
 (a)  $\frac{P_t}{\text{strength of solid plate}}$  (b)  $\frac{P_s}{\text{strength of solid plate}}$   
 (c)  $\frac{P_c}{\text{strength of solid plate}}$  (d)  $\frac{\text{least of } P_t, P_s \text{ and } P_c}{\text{strength of solid plate}}$   
 (e)  $\frac{\text{maximum of } P_t, P_s \text{ and } P_c}{\text{strength of solid plate}}$  (f) none of the above.
178. In riveted joint the tensile, shearing and crushing stresses are based on the  
 (a) diameter of drilled hole (b) diameter of rivet  
 (c) mean of the diameter of rivet and drilled hole  
 (d) none of the above.
179. Generally a rivet joint fails by  
 (a) shearing of rivets (b) crushing of rivets  
 (c) tearing of the plate across the row of rivets  
 (d) all of the above (e) any one of the above.
180. A welded joint as compared to riveted joint, has  
 (a) less strength (b) more strength  
 (c) same strength (d) none of the above.
181. In the diamond-riveted arrangement, the nine rivets have been arranged in four rows with one rivet in the first row, two rivets in the second row, three rivets in the third row and three rivets in the fourth row. The weakest section is the section passing through  
 (a) fourth row (b) third row  
 (c) second row (d) one rivet hole in the first row.
182. The efficiency of a diamond-riveted joint, having width of the plate as  $b$  and diameter of hole as  $d$ , is equal to  
 (a)  $\frac{d}{b}$  (b)  $\frac{b+d}{b}$   
 (c)  $\frac{b-d}{b}$  (d)  $\frac{b-d}{d}$ .
183. The material, of which rivets are made, should be  
 (a) hard (b) malleable  
 (c) ductile (d) tough.
184. Strut is defined as a  
 (a) member of a structure which carries a tensile load  
 (b) member of a structure which carries an axial compressive load  
 (c) vertical member of a structure which carries a tensile load  
 (d) none of the above.

185. Column is defined as a  
 (a) member of a structure which carries a tensile load  
 (b) member of a structure which carries an axial compressive load  
 (c) vertical member of a structure which carries a tensile load  
 (d) vertical member of a structure which carries an axial compressive load.
186. The maximum axial compressive load which a column can take without failure by lateral deflection is called  
 (a) critical load (b) buckling load  
 (c) crippling load (d) any one of the above.
187. Slenderness ratio is defined as the ratio of  
 (a) equivalent length of the column to the minimum radius of gyration  
 (b) length of the column to the minimum radius of gyration  
 (c) length of the column to the area of cross-section of the column  
 (d) minimum radius of gyration to the area of cross-section of the column.
188. Buckling factor is defined as the ratio of  
 (a) equivalent length of a column to the minimum radius of gyration  
 (b) length of the column to the minimum radius of gyration  
 (c) length of the column to the area of cross-section of the column  
 (d) none of the above.
189. A loaded column is having the tendency to deflect. On account of this tendency, the critical load  
 (a) decreases with the decrease in length  
 (b) decreases with the increase in length  
 (c) first decreases then increases with the decrease in length  
 (d) first increases then decreases with the decrease in length.
190. A loaded column fails due to  
 (a) stress due to direct load (b) stress due to bending  
 (c) both (a) and (b) (d) none of the above.
191. The crippling load, according to Euler's theory of long columns, when both ends of the column are hinged, is equal to  
 (a)  $\frac{4\pi^2 EI}{l^2}$  (b)  $\frac{\pi^2 EI}{l^2}$   
 (c)  $\frac{\pi^2 EI}{4l^2}$  (d)  $\frac{2\pi^2 EI}{l^2}$   
 where  $l$  = length of column.
192. The crippling load, according to Euler's theory of long column when one end of the column is fixed and other end is free, is equal to  
 (a)  $\frac{4\pi^2 EI}{l^2}$  (b)  $\frac{\pi^2 EI}{l^2}$   
 (c)  $\frac{\pi^2 EI}{4l^2}$  (d)  $\frac{2\pi^2 EI}{l^2}$ .

193. The crippling load, according to Euler's theory of long column when both ends of the column are fixed, is equal to

(a)  $\frac{4\pi^2 EI}{l^2}$  (b)  $\frac{\pi^2 EI}{l^2}$   
 (c)  $\frac{\pi^2 EI}{4l^2}$  (d)  $\frac{2\pi^2 EI}{l^2}$

194. The crippling load, according to Euler's theory of long column when one end of the column is fixed and the other end is hinged, is equal to

(a)  $\frac{4\pi^2 EI}{l^2}$  (b)  $\frac{\pi^2 EI}{l^2}$   
 (c)  $\frac{\pi^2 EI}{4l^2}$  (d)  $\frac{2\pi^2 EI}{l^2}$

195. The ratio of crippling load, for a column of length ( $l$ ) with both ends fixed to the crippling load of the same column with both ends hinged, is equal to

(a) 2.0 (b) 4.0  
 (c) 0.25 (d) 0.50

196. The ratio of crippling load, for a column of length ( $l$ ) with both ends fixed to the crippling load of the same column with one end fixed and other end is free, is equal to

(a) 2.0 (b) 4.0  
 (c) 8.0 (d) 16.0

197. The ratio of crippling load, for a column of length ( $l$ ) with both ends fixed to the crippling load of the same column with one end fixed and other end is hinged, is equal to

(a) 2.0 (b) 4.0  
 (c) 8.0 (d) 16.0

198. The equivalent length of a given column with given end conditions is the length of a column of the same material and section with hinged ends having crippling load equal to

(a) two times that of the given column (b) half that of given column  
 (c) four times that of the given column (d) that of the given column.

199. The equivalent length is equal to actual length of a column with

(a) one end fixed and other end free (b) both ends fixed  
 (c) one end fixed and other end hinged (d) both ends hinged.

200. The equivalent length is twice the actual length of a column with

(a) one end fixed and other end free (b) both ends fixed  
 (c) one end fixed and other end hinged (d) both ends hinged.

201. The equivalent length is equal to half of the actual length of a column with

(a) one end fixed and other end free (b) both ends fixed  
 (c) one end fixed and other end hinged (d) both ends hinged.

202. The equivalent length is equal to actual length divided by  $\sqrt{2}$  for a column with

(a) one end fixed and other end free (b) both ends fixed  
 (c) one end fixed and other end hinged (d) both ends hinged.

203. The equivalent length is equal to four times the actual length of a column with

(a) one end fixed and other end free (b) both ends fixed  
 (c) one end fixed and other end hinged (d) both ends hinged  
 (e) none of the above.

204. Choose the wrong statement

(a) Column is a vertical member of a structure which carries an axial compressive load.  
 (b) The ratio of length of a column to its minimum radius of gyration is called slenderness ratio.  
 (c) A column tends to buckle in the direction of the minimum moment of inertia.  
 (d) The equivalent length of a column with one end fixed and other end is free is half of its actual length.

205. Choose the correct statement

(a) Euler's formula holds good only for short columns.  
 (b) A short column is one which has the ratio of its length to least radius of gyration more than 100.  
 (c) A column with both ends fixed has minimum equivalent (or effective) length.  
 (d) The equivalent length of a column with one end fixed and other end hinged is half of its actual length.

206. Rankine's formula is an empirical formula with is used for

(a) long columns (b) short columns  
 (c) both long and short columns (d) none of the above.

207. The crippling load by Rankine's formula is

(a)  $\frac{\sigma_c A}{1 + a \left(\frac{l}{k}\right)^2}$  (b)  $\frac{\sigma_c A}{1 + a \left(\frac{l_e}{k}\right)^2}$   
 (c)  $\frac{\sigma_c A}{1 - a \left(\frac{l}{k}\right)^2}$  (d)  $\frac{\sigma_c A}{1 - a \left(\frac{l_e}{k}\right)^2}$

where  $A$  = area of cross-section of the column

$\sigma_c$  = crushing stress

$a$  = Rankine's constant

$k$  = least radius of gyration

$l$  = actual length of column

$l_e$  = equivalent length of column.

208. The Rankine's constant ( $a$ ) in Rankine's formula is equal to

(a)  $\frac{\pi^2 E}{\sigma_c}$  (b)  $\frac{\pi^2}{E \sigma_c}$   
 (c)  $\frac{E \sigma_c}{\pi^2}$  (d)  $\frac{\sigma_c}{\pi^2 E}$

199. The Rankine's constant ( $\alpha$ ) for a given material of a column depends upon the  
 (a) length of column (b) diameter of the column  
 (c) length and diameter (d) none of the above.
210. The expression  $\frac{(\sigma_c A)}{1 + b \left(\frac{l_e}{d}\right)^2}$  is known as  
 (a) Rankine's formula (b) Gordon's formula  
 (c) Straight line of formula (d) Johnson's parabolic formula  
 where  $d$  = least diameter or width of the section  
 $b$  = constant and  $l_e$  = equivalent length.
211. A cantilever of length ( $l$ ) carries a load whose intensity varies uniformly from zero at the free end to  $w$  per unit length at the fixed end, the bending moment diagram will be a  
 (a) straight line curve (b) parabolic curve  
 (c) cubic curve (d) combination of (a) and (b).
212. A simply supported beam is overhanging equally on both sides and carries a uniformly distributed load of  $w$  per unit length over the whole length. The length between the supports is ( $l$ ) and length of overhang to one side is ' $a$ '. If  $l > 2a$  then the number of points of contra-flexure will be  
 (a) zero (b) one  
 (c) two (d) three.
213. If in question 212,  $l = 2a$ , the number of points of contra-flexure will be  
 (a) zero (b) one  
 (c) two (d) three.
214. If in question 212,  $l < 2a$ , the number of points of contra-flexure will be  
 (a) zero (b) one  
 (c) two (d) three.
215. In question 212, the shear force diagram will consist of  
 (a) two triangles (b) two rectangles  
 (c) four triangles (d) four rectangles.
216. For the same loading, the maximum bending moment for a fixed beam as compared to simply supported beam is  
 (a) more (b) less  
 (c) same (d) none of the above.
217. For the same loading, the maximum deflection for a fixed beam as compared to simply supported beam is  
 (a) more (b) same  
 (c) less (d) none of the above.
218. In a fixed beam, temperature variation produces  
 (a) large stresses (b) small stresses  
 (c) zero stress (d) none of the above.
219. In a simply supported beam, the temperature variation produces  
 (a) large stresses (b) small stresses  
 (c) zero stress (d) none of the above.

## 25.2. ANSWERS OF OBJECTIVE TYPE QUESTIONS

- |          |          |          |          |          |          |
|----------|----------|----------|----------|----------|----------|
| 1. (b)   | 2. (d)   | 3. (a)   | 4. (c)   | 5. (b)   | 6. (a)   |
| 7. (c)   | 8. (c)   | 9. (b)   | 10. (a)  | 11. (b)  | 12. (b)  |
| 13. (a)  | 14. (b)  | 15. (c)  | 16. (a)  | 17. (b)  | 18. (d)  |
| 19. (b)  | 20. (b)  | 21. (b)  | 22. (e)  | 23. (c)  | 24. (c)  |
| 25. (a)  | 26. (c)  | 27. (c)  | 28. (c)  | 29. (b)  | 30. (c)  |
| 31. (c)  | 32. (c)  | 33. (c)  | 34. (a)  | 35. (b)  | 36. (b)  |
| 37. (b)  | 38. (c)  | 39. (b)  | 40. (b)  | 41. (b)  | 42. (d)  |
| 43. (b)  | 44. (d)  | 45. (c)  | 46. (a)  | 47. (d)  | 48. (b)  |
| 49. (c)  | 50. (d)  | 51. (b)  | 52. (d)  | 53. (e)  | 54. (d)  |
| 55. (c)  | 56. (d)  | 57. (a)  | 58. (b)  | 59. (d)  | 60. (a)  |
| 61. (d)  | 62. (b)  | 63. (d)  | 64. (d)  | 65. (a)  | 66. (b)  |
| 67. (a)  | 68. (e)  | 69. (d)  | 70. (c)  | 71. (c)  | 72. (c)  |
| 73. (b)  | 74. (b)  | 75. (b)  | 76. (c)  | 77. (a)  | 78. (b)  |
| 79. (b)  | 80. (b)  | 81. (a)  | 82. (a)  | 83. (d)  | 84. (d)  |
| 85. (c)  | 86. (d)  | 87. (d)  | 88. (b)  | 89. (c)  | 90. (d)  |
| 91. (d)  | 92. (c)  | 93. (b)  | 94. (c)  | 95. (b)  | 96. (c)  |
| 97. (c)  | 98. (b)  | 99. (c)  | 100. (b) | 101. (c) | 102. (d) |
| 103. (d) | 104. (c) | 105. (c) | 106. (b) | 107. (c) | 108. (a) |
| 109. (c) | 110. (d) | 111. (b) | 112. (c) | 113. (c) | 114. (d) |
| 115. (b) | 116. (a) | 117. (c) | 118. (b) | 119. (a) | 120. (c) |
| 121. (c) | 122. (d) | 123. (c) | 124. (b) | 125. (a) | 126. (b) |
| 127. (c) | 128. (c) | 129. (b) | 130. (b) | 131. (a) | 132. (b) |
| 133. (d) | 134. (c) | 135. (a) | 136. (d) | 137. (a) | 138. (b) |
| 139. (a) | 140. (d) | 141. (c) | 142. (c) | 143. (d) | 144. (a) |
| 145. (b) | 146. (c) | 147. (b) | 148. (a) | 149. (b) | 150. (d) |
| 151. (a) | 152. (c) | 153. (b) | 154. (c) | 155. (b) | 156. (b) |
| 157. (a) | 158. (c) | 159. (d) | 160. (c) | 161. (b) | 162. (c) |
| 163. (c) | 164. (a) | 165. (d) | 166. (c) | 167. (a) | 168. (b) |
| 169. (b) | 170. (a) | 171. (b) | 172. (b) | 173. (c) | 174. (b) |
| 175. (c) | 176. (d) | 177. (d) | 178. (a) | 179. (e) | 180. (b) |
| 181. (d) | 182. (c) | 183. (c) | 184. (b) | 185. (d) | 186. (d) |
| 187. (b) | 188. (a) | 189. (b) | 190. (c) | 191. (b) | 192. (c) |
| 193. (a) | 194. (d) | 195. (b) | 196. (d) | 197. (a) | 198. (d) |
| 199. (d) | 220. (a) | 201. (b) | 202. (c) | 203. (e) | 204. (d) |
| 205. (c) | 206. (c) | 207. (b) | 208. (d) | 209. (d) | 210. (b) |
| 211. (c) | 212. (c) | 213. (b) | 214. (a) | 215. (c) | 216. (b) |
| 217. (c) | 218. (a) | 219. (c) |          |          |          |

### 25.3. OBJECTIVE TYPE QUESTIONS FROM COMPETITIVE EXAMINATIONS

1. For the state of plane stress shown in Fig. 1, the maximum and minimum principal stresses are :

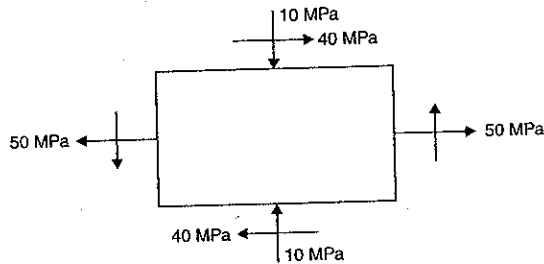

Fig. 1

- (a) 60 MPa and 30 MPa  
(b) 50 MPa and 10 MPa  
(c) 40 MPa and 20 MPa  
(d) 70 MPa and 30 MPa.
2. Which of the following is true ( $\mu$  = Poisson's ratio)
- (a)  $0 < \mu < -\frac{1}{2}$   
(b)  $1 < \mu < 0$   
(c)  $1 < \mu < -1$   
(d)  $\infty < \mu < -\infty$ .
3. For most brittle materials, the ultimate strength in compression is much large than the ultimate strength in tension. This is mainly due to
- (a) presence of flaws and microscopic cracks or cavities.  
(b) necking in tension  
(c) severity of tensile stress as compared to compressive stress  
(d) non-linearity of stress-strain diagram.
4. Bending moment  $M$  and torque  $T$  is applied on a solid circular shaft. If the maximum bending stress equals to maximum shear stress developed, then  $M$  is equal to
- (a)  $\frac{T}{2}$   
(b)  $T$   
(c)  $2T$   
(d)  $4T$ .
5. When bending moment  $M$  and torque  $T$  is applied on a shaft then equivalent torque is
- (a)  $M + T$   
(b)  $\sqrt{M^2 + T^2}$   
(c)  $\frac{1}{2}\sqrt{M^2 + T^2}$   
(d)  $\frac{1}{2}(M + \sqrt{M^2 + T^2})$ .

6. The bending moment diagram for the case shown in Fig. 2 below will be as shown in figure.

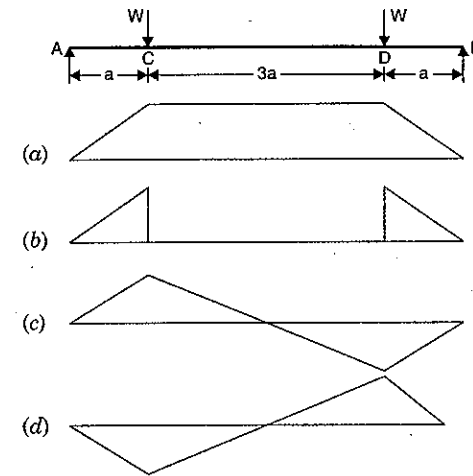

Fig. 2

7. If a prismatic bar be subjected to an axial tensile stress  $\sigma$ , the shear stress induced at a plane inclined at  $\theta$  with the axis will be
- (a)  $\frac{\sigma}{2} \sin 2\theta$   
(b)  $\frac{\sigma}{2} \cos 2\theta$   
(c)  $\frac{\sigma}{2} \cos^2 \theta$   
(d)  $\frac{\sigma}{2} \sin^2 \theta$ .
8. A vertical hanging bar of length  $L$  and weighing  $w$  N/unit length carries a load  $W$  at the bottom as shown in Fig. 3. The tensile force in the bar at a distance  $y$  from the support will be given by
- (a)  $W + w \times L$   
(b)  $W + w(L - y)$   
(c)  $(W + w) \times \frac{y}{L}$   
(d)  $W + \frac{W}{w}(L - y)$ .
9. In case of bi-axial state of normal stresses, the normal stress on  $45^\circ$  plane is equal to
- (a) sum of normal stresses  
(b) difference of normal stresses  
(c) half the sum of normal stresses  
(d) half the difference of normal stresses.
10. The temperature stress is a function of
1. Co-efficient of linear expansion
  2. Temperature rise
  3. Modulus of elasticity.
- The correct answer is
- (a) 1 and 2 only  
(b) 1 and 3 only  
(c) 2 and 3 only  
(d) 1, 2 and 3 only.

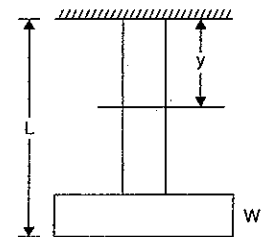

Fig. 3

11. When two springs of equal lengths are arranged to form a cluster spring then which of the following statements are true :

1. Angle of twist in both the springs will be equal
2. Deflection of both the springs will be equal
3. Load taken by each spring will be half the total load
4. Shear stress in each spring will be equal

- (a) 1 and 2 only                      (b) 2 and 3 only  
(c) 3 and 4 only                      (d) 1, 2 and 4 only.

12. When  $\sigma$  and Young's modulus of elasticity  $E$  remains constant, the energy absorbing capacity of part subjected to dynamic forces, is a function of its

- (a) length                                      (b) cross-section  
(c) volume                                      (d) none of the above.

13. If the principal stresses corresponding to a two-dimensional state of stress are  $\sigma_1$  and  $\sigma_2$  when  $\sigma_1$  is greater than  $\sigma_2$  and both are tensile, then which one of the following would be correct criterion for failure by yielding, according to maximum shear stress theory ?

- (a)  $\frac{\sigma_1 - \sigma_2}{2} = \pm \frac{\sigma_{yp}}{2}$                       (b)  $\frac{\sigma_1}{2} = \pm \frac{\sigma_{yp}}{2}$   
(c)  $\frac{\sigma_2}{2} = \pm \frac{\sigma_{yp}}{2}$                       (d)  $\sigma_1 = \pm 2\sigma_{yp}$ .

14. The buckling load will be maximum for a column, if

- (a) one end of the column is clamped and other end is free  
(b) both ends of the column are clamped  
(c) both ends of the column are hinged  
(d) one end of the column is hinged and other end is free.

15. A length of 10 mm diameter steel wire is coiled to a close coiled helical spring having 8 coils of 75 mm mean diameter, and the spring has a stiffness  $k$ . If the same length of the wire is coiled to 10 coils of 60 mm mean diameter, then the spring stiffness will be

- (a)  $k$                       (b)  $1.25 k$                       (c)  $1.56 k$                       (d)  $1.95 k$ .

16. A metal pipe of 1 m diameter contains a fluid having a pressure of 100 N/cm<sup>2</sup>. If the permissible tensile stress in the metal is 2 kN/cm<sup>2</sup>, then the thickness of the metal required for making the pipe would be

- (a) 5 mm                      (b) 10 mm                      (c) 20 mm                      (d) 25 mm.

17. Circumferential and longitudinal strains in cylindrical boiler under internal steam pressure, are  $e_1$  and  $e_2$  respectively. Change in volume of the boiler cylinder per unit volume will be

- (a)  $e_1 + 2e_2$                       (b)  $e_1 e_2^2$                       (c)  $2e_1 + e_2$                       (d)  $e_1^2 e_2$ .

18. In the assembly of pulley, key and shaft

- (a) pulley is made the weakest  
(b) key is made the weakest  
(c) key is made the strongest  
(d) all the three are designed for equal strength.

19. Shear stress distribution diagram of a beam of rectangular cross-section, subject to transverse loading will be

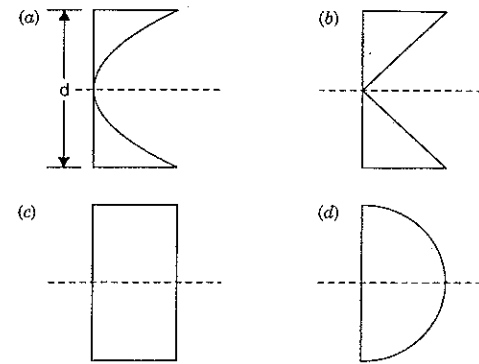

Fig. 4

20. A horizontal beam with square cross-section is simply supported with sides of the square horizontal and vertical and carries a distributed loading that produces maximum bending stress  $\sigma$  in the beam. When the beam is placed with one of the diagonals horizontal, the maximum bending stress will be

- (a)  $\frac{\sigma}{\sqrt{2}}$                       (b)  $\sigma$                       (c)  $\sqrt{2} \times \sigma$                       (d)  $2\sigma$ .

21. A shaft was initially subjected to bending moment and then was subjected to torsion. If the magnitude of the bending moment is found to be the same as that of the torque, then the ratio of maximum bending stress to shear stress would be

- (a) 0.25                      (b) 0.50                      (c) 2.0                      (d) 4.0.

22. A simply supported beam of rectangular section 4 cm by 6 cm carries a mid-span concentrated load such that 6 cm side lies parallel to the line of action of loading ; deflection under the load is  $\delta$ . If the beam is now supported with the 4 cm side parallel to the line of action of loading, the deflection under the load will be

- (a)  $0.44 \times \delta$                       (b)  $0.67 \times \delta$                       (c)  $1.50 \times \delta$                       (d)  $2.25 \times \delta$ .

23. A beam AB is hinge-supported at its ends and is loaded by a couple  $P \times C$  as shown in Fig. 5, below. The magnitude of shearing force at a section  $x$  of the beam is

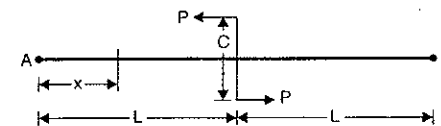

Fig. 5

- (a) 0                      (b)  $P$                       (c)  $\frac{P}{2L}$                       (d)  $\frac{P \times C}{2L}$ .

24. The frictional torque for square thread at mean radius ( $R$ ) while raising load ( $W$ ) is given by  
 (a)  $WR \times \tan(\phi - \alpha)$  (b)  $WR \times \tan(\phi + \alpha)$   
 (c)  $WR \times \tan \alpha$  (d)  $WR \times \tan \phi$   
 where  $\phi$  = angle of friction and  $\alpha$  = Helix angle.
25. Design of shafts made of brittle materials is based on  
 (a) Guest's theory (b) Rankine's theory  
 (c) St. Venant's theory (d) Von Mises theory.
26. Principal stresses at a point in plane stressed element are  $\sigma_x = \sigma_y = 5000 \text{ N/cm}^2$ . Normal stress on the plane inclined at  $45^\circ$  to the  $x$ -axis will be  
 (a) 0 (b)  $5000 \text{ N/cm}^2$   
 (c)  $7070 \text{ N/cm}^2$  (d)  $10000 \text{ N/cm}^2$ .
27. State of stress in plane element is shown in Fig. 6 below. Which one of the following figures shown in Fig. 7 is the correct sketch of Mohr's circle of the state of stress?

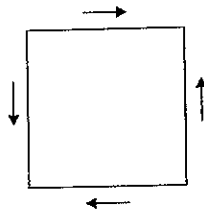

Fig. 6

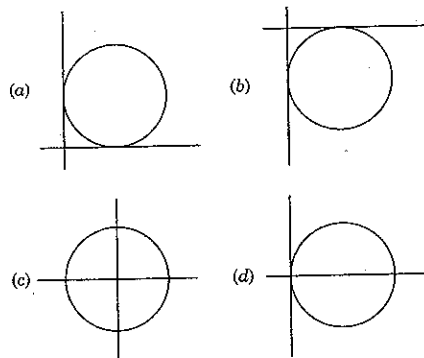

Fig. 7

28. A steel rod of  $1 \text{ sq cm}$  cross-sectional area is  $100 \text{ cm}$  long and has a Young's modulus of elasticity  $20 \times 10^6 \text{ N/cm}^2$ . It is subjected to an axial pull of  $20 \text{ kN}$ . The elongation of the rod will be  
 (a)  $0.05 \text{ cm}$  (b)  $0.1 \text{ cm}$  (c)  $0.15 \text{ cm}$  (d)  $0.20 \text{ cm}$ .
29. If the area of cross-section of a wire is circular and if the radius of this wire decreases to half its original value due to stretch to the wire by a load, then modulus of elasticity of the wire be

- (a) one-fourth of its original value (b) halved  
 (c) doubled (d) unaffected

E depends upon the material. It is independent of area, load etc.

30. Match list I with list II and select the correct answer using codes given below the lists :

List I (Material properties)	List II (Test to determine material properties)
A. Ductility	1. Impact test
B. Toughness	2. Fatigue test
C. Endurance limit	3. Tension test
D. Resistance to penetration	4. Hardness test

Codes :

(a)	A	B	C	D
(b)	3	2	1	4
(c)	4	2	1	3
(d)	3	1	2	4
(e)	4	1	2	3

31. If a material had a modulus of elasticity of  $21 \times 10^6 \text{ N/cm}^2$  and a modulus of rigidity of  $8 \times 10^6 \text{ N/cm}^2$ , then approximate value of the Poisson's ratio of the material would be  
 (a) 0.26 (b) 0.31 (c) 0.47 (d) 0.5.
32. A shaft can safely transmit  $90 \text{ kW}$  while rotating at a given speed. If this shaft is replaced by a shaft of diameter double the previous one and rotated at half the speed of the previous, the power that can be transmitted by the new shaft is  
 (a)  $90 \text{ kW}$  (b)  $180 \text{ kW}$  (c)  $360 \text{ kW}$  (d)  $720 \text{ kW}$ .
33. A cold rolled steel shaft is designed on the basis of maximum shear stress theory. The principal stresses induced at its critical section are  $60 \text{ MPa}$  and  $-60 \text{ MPa}$  respectively. If the yield stress for the shaft material is  $360 \text{ MPa}$ , the factor of safety of the design is  
 (a) 2 (b) 3 (c) 4 (d) 5.
34. An eccentrically loaded riveted joint is shown in Fig. 8 with 4 rivets at  $P$ ,  $Q$ ,  $R$  and  $S$  which of the rivets are the most loaded?  
 (a)  $P$  and  $Q$  (b)  $Q$  and  $R$  (c)  $R$  and  $S$  (d)  $S$  and  $P$ .

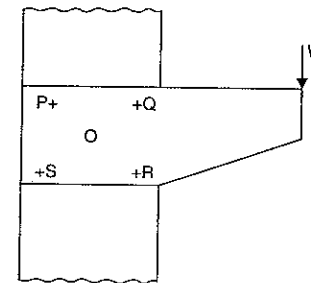

Fig. 8

35. When a helical compression spring is cut into two equal halves, the stiffness of each of the resulting springs will be  
 (a) unaltered (b) double (c) one-half (d) one-fourth.
36. While calculating the stress induced in a closed coil helical spring, Wahl's factor must be considered to account for  
 (a) the curvature and stress concentration effect  
 (b) shock loading  
 (c) poor service conditions  
 (d) fatigue loading.
37. A straight bar is fixed at the edges A and B as shown in Fig. 9. Its elastic modulus is  $E$  and cross-section is  $A$ . There is a load  $P = 120$  N acting at C. Determine the reactions at the ends

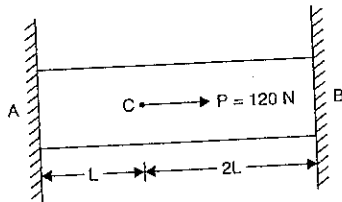

Fig. 9

- (a) 60 N at A, 60 N at B  
 (b) 30 N at A, 90 N at B  
 (c) 40 N at A, 80 N at B  
 (d) 80 N at A, 40 N at B.
38. For a material, the modulus of rigidity is 100 G Pa and Poisson's ratio is 0.25. The value of modulus of elasticity in G Pa is  
 (a) 125 (b) 150 (c) 200 (d) 250.
39. A rigid beam of negligible weight is supported in a horizontal position by two rods of steel and aluminium 2 m and 1 m long having values of cross-sectional areas  $1 \text{ cm}^2$  and  $2 \text{ cm}^2$  and  $E$  of 200 G Pa and 100 G Pa respectively. A load  $P$  is applied as shown in Fig. 10 below :

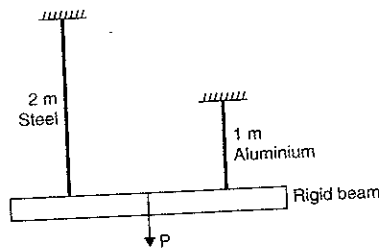

Fig. 10

- If the rigid beam is to remain horizontal, then  
 (a) the load on both rods should be equal  
 (b) the load on aluminium rod should be twice the load on steel  
 (c) the load on the steel rod should be twice the load on aluminium  
 (d) the load  $P$  must be applied at the centre of the beam.
40. A thin cylinder of radius  $r$  and thickness  $t$  when subjected to an internal hydrostatic pressure  $p$  causes a radial displacement  $u$ , then the tangential strain caused is  
 (a)  $\frac{du}{dr}$  (b)  $\frac{1}{r} \cdot \frac{du}{dr}$  (c)  $\frac{u}{r}$  (d)  $\frac{2u}{r}$ .
41. Determine the stiffness of the beam shown in Fig. 11 given below :

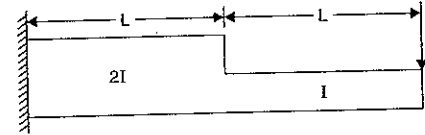

Fig. 11

When :  $I = 375 \times 10^{-4} \text{ m}^4$   
 $L = 0.5 \text{ m}$   
 $E = 200 \text{ GPa}$

- The stiffness is given by  
 (a)  $12 \times 10^{10} \text{ N/m}$  (b)  $10 \times 10^{10} \text{ N/m}$   
 (c)  $4 \times 10^{10} \text{ N/m}$  (d)  $8 \times 10^{10} \text{ N/m}$ .
42. The strain energy stored in a body of volume  $V$  subjected to uniform stress  $\sigma$  is  
 (a)  $\frac{\sigma \times E}{V}$  (b)  $\frac{\sigma E^2}{V}$  (c)  $\frac{\sigma \times V^2}{E}$  (d)  $\frac{\sigma^2}{2E} \times V$ .
43. For the same internal diameter, wall thickness, material and internal pressure, the ratio of maximum stress, induced in a thin cylindrical and in a thin spherical vessel will be  
 (a) 2 (b)  $\frac{1}{2}$  (c) 4 (d)  $\frac{1}{4}$ .
44. Two identical springs labelled as 1 and 2 are arranged in series and subjected to force  $F$  as shown in Fig. 12.

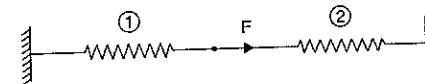

Fig. 12

Assume that each spring constant is  $k$ . The strain energy stored in spring 1 is  
 (a)  $\frac{F^2}{2k}$  (b)  $\frac{F^2}{4k}$  (c)  $\frac{F^2}{8k}$  (d)  $\frac{F^2}{16k}$ .



45. A rod having cross-sectional area  $100 \times 10^{-6} \text{ m}^2$  is subjected to a tensile load. Based on the Tresca failure criterion, if the uniaxial yield stress of the material is 200 MPa, the failure load is  
 (a) 10 kN (b) 20 kN (c) 100 kN (d) 200 kN.
46. Wire diameter, mean coil diameter and number of turns of a closely-coiled steel spring are  $d$ ,  $D$  and  $N$  respectively and stiffness of the spring is  $k$ . A second spring is made of the same steel but with wire diameter, mean coil diameter and number of turns as  $2d$ ,  $2D$  and  $2N$  respectively. The stiffness of the new spring is  
 (a)  $k$  (b)  $2k$  (c)  $4k$  (d)  $8k$ .
47. If the diameter of a long column is reduced by 20%, the percentage of reduction in Euler's buckling load is  
 (a) 4 (b) 36 (c) 49 (d) 59.
48. With one fixed end and other free end, a column of length  $L$  buckles at load  $P_1$ . Another column of same length and same cross-section fixed at both ends buckles at load  $P_2$ . Then  $P_2/P_1$  is  
 (a) 1 (b) 2 (c) 4 (d) 16.
49. The principal stresses  $\sigma_1$ ,  $\sigma_2$  and  $\sigma_3$  at a point respectively are 80 MPa, 30 MPa and -40 MPa. The maximum shear stress is  
 (a) 25 MPa (b) 35 MPa (c) 55 MPa (d) 60 MPa.
50. The Poisson's ratio of a material which has Young's modulus of 120 GPa and shear modulus of 50 GPa, is  
 (a) 0.1 (b) 0.2 (c) 0.3 (d) 0.4.

## 25.4. ANSWERS WITH EXPLANATIONS

- |         |         |         |         |         |         |
|---------|---------|---------|---------|---------|---------|
| 1. (d)  | 2. (a)  | 3. (a)  | 4. (a)  | 5. (b)  | 6. (a)  |
| 7. (a)  | 8. (b)  | 9. (e)  | 10. (d) | 11. (c) | 12. (c) |
| 13. (b) | 14. (b) | 15. (c) | 16. (d) | 17. (c) | 18. (b) |
| 19. (d) | 20. (c) | 21. (c) | 22. (d) | 23. (d) | 24. (b) |
| 25. (b) | 26. (b) | 27. (c) | 28. (b) | 29. (d) | 30. (c) |
| 31. (b) | 32. (c) | 33. (b) | 34. (d) | 35. (b) | 36. (a) |
| 37. (d) | 38. (d) | 39. (b) | 40. (c) | 41. (c) | 42. (d) |
| 43. (a) | 44. (c) | 45. (b) | 46. (a) | 47. (d) | 48. (d) |
| 49. (d) | 50. (b) |         |         |         |         |

## EXPLANATIONS

1. Here  $\sigma_x = 50 \text{ MPa}$   
 $\sigma_y = -10 \text{ MPa}$   
 $\tau_{xy} = 40 \text{ MPa}$

The principal stresses  $\sigma_1$  and  $\sigma_2$  are given as

$$\sigma_1, \sigma_2 = \frac{\sigma_x + \sigma_y}{2} \pm \sqrt{\left(\frac{\sigma_x - \sigma_y}{2}\right)^2 + \tau_{xy}^2}$$

$$= \frac{50 + (-10)}{2} \pm \sqrt{\left[\frac{50 - (-10)}{2}\right]^2 + 40^2}$$

$$= 20 \pm \sqrt{30^2 + 40^2}$$

$$= 20 \pm 50,$$

- $\therefore \sigma_1 = 20 + 50 = 70 \text{ MPa}$   
 and  $\sigma_2 = 20 - 50 = -30 \text{ MPa} = 30 \text{ MPa (compressive)}$  Ans.

2.  $\mu = \text{Poisson's ratio} = \frac{\text{Lateral strain}}{\text{Longitudinal strain}}$

The lateral strain is opposite to longitudinal strain. This means if longitudinal strain is tensile, then lateral strain is compressive. Hence  $\mu$  is negative. For most of the material  $\mu$  lies between -0.25 to -0.40.

4. Bending stress,  $\sigma_b = \frac{M}{I} \times y$

$$\therefore (\sigma_b)_{\max} = \frac{M}{I} \times \frac{d}{2} \quad \text{where } I = \frac{\pi}{64} d^4$$

$$= \frac{M}{\frac{\pi}{64} d^4} \times \frac{d}{2} = \frac{32M}{\pi d^3}$$

$$T = \frac{\pi}{16} \times d^3 \times \tau_{\max}$$

$$\therefore \tau_{\max} = \frac{16T}{\pi d^3}$$

- $\therefore$  If  $\sigma_{\max} = \tau_{\max}$   
 Then  $\frac{32M}{\pi d^3} = \frac{16T}{\pi d^3}$  or  $M = \frac{T}{2}$  Ans.

5. Due to bending moment ( $m$ ), the bending stress will be produced in the shaft. This bending stress ( $\sigma_b$ ) is given by

$$\sigma_b = \frac{32M}{\pi d^3}$$

Due to torque ( $T$ ), the shear stress will be produced. This shear stress ( $\tau$ ) is given by

$$\tau = \frac{16T}{\pi d^3}$$

$\therefore$  The principal stresses due to bending and shear stresses are

$$\sigma_1 \text{ and } \sigma_2 = \frac{\sigma_b}{2} \pm \sqrt{\left(\frac{\sigma_b}{2}\right)^2 + \tau^2}$$

$$= \frac{1}{2} \times \frac{32M}{\pi d^3} \pm \sqrt{\left(\frac{16M}{\pi d^3}\right)^2 + \left(\frac{16T}{\pi d^3}\right)^2}$$

For finding equivalent torque ( $T_e$ ) when the shaft is subjected to bending moment and torque, we should determine the maximum shear produced by the principal stresses.

Max. shear stress due to principal stresses is given by

$$\tau_{\max} = \frac{\sigma_1 - \sigma_2}{2}$$

$$= \frac{\sqrt{\left(\frac{16M}{\pi d^3}\right)^2 + \left(\frac{16T}{\pi d^3}\right)^2}}{2}$$

$$= \frac{16}{\pi d^3} \sqrt{M^2 + T^2}$$

where  $\sigma_1 = \frac{16M}{\pi d^3} + \sqrt{\left(\frac{16M}{\pi d^3}\right)^2 + \left(\frac{16T}{\pi d^3}\right)^2}$

and  $\sigma_2 = \frac{16M}{\pi d^3} - \sqrt{\left(\frac{16M}{\pi d^3}\right)^2 + \left(\frac{16T}{\pi d^3}\right)^2}$

Equivalent torque is

$$T_e = \frac{\pi}{16} \times d^3 \times \tau_{\max}$$

$$= \frac{\pi}{16} \times d^3 \times \left[ \frac{16}{\pi d^3} \times \sqrt{M^2 + T^2} \right]$$

$$= \sqrt{M^2 + T^2} \text{ Ans.}$$

7.

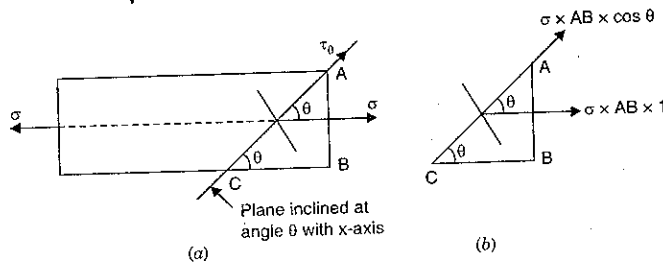

Fig. 13

Force on  $AB = \sigma \times \text{Area} = \sigma \times AB \times 1$  (Thickness = unity)

Force on  $AC = (\sigma \times AB) \times \cos \theta$

$\therefore \tau_{\theta} = \text{Shear stress on the plane } AC$

$$= \frac{\text{Shear force}}{\text{Area}} = \frac{\sigma \times AB \times \cos \theta}{AC \times 1} = \sigma \times \sin \theta \times \cos \theta \quad \left( \because \frac{AB}{AC} = \sin \theta \right)$$

$$= \frac{\sigma}{2} \times 2 \sin \theta \cos \theta = \frac{\sigma}{2} \times \sin 2\theta \text{ Ans.}$$

8. The tensile force in the bar at a distance  $y$  from the support = Weight at the lower end + Weight of bar for a length  $(L - y)$  =  $W + w(L - y)$ . Ans.

9. The normal stress on the inclined plane in case of biaxial stress system is given by

$$\sigma_{\theta} = \frac{1}{2}(\sigma_x + \sigma_y) + \frac{1}{2}(\sigma_x - \sigma_y) \cos 2\theta$$

$$\sigma_{45^\circ} = \frac{1}{2}(\sigma_x + \sigma_y) + \frac{1}{2}(\sigma_x - \sigma_y) \cos 90^\circ$$

$$= \frac{1}{2}(\sigma_x + \sigma_y) \text{ Ans.}$$

10. Temperature stress =  $\alpha \times (\Delta t) + E$

Where  $\alpha$  = Co-efficient of linear expansion,  
 $\Delta t$  = Temperature rise, and  
 $E$  = Modulus of elasticity.

Hence temperature stress depends upon all the three and (d) is the answer.

12. The energy absorbed by a part subject to dynamic force is given by

$$U = \frac{\sigma^2}{2E} \times \text{volume}$$

when  $\sigma$  and  $E$  are constant then

$$U \propto \text{volume}$$

Hence (c) is the answer.

13. The criterion of failure according to maximum shear stress theory is

$$\frac{\sigma_1 - \sigma_2}{2} = \pm \frac{\sigma_{yp}}{2}$$

when the principal stresses  $\sigma_1$  and  $\sigma_2$  are opposite  
*i.e.*, one is tensile then other is compressive

But if both are tensile (or compressive), then  $\frac{\sigma_1 - \sigma_2}{2}$  will not represent the maximum shear stress. It will represent the stress less than maximum shear stress. But  $\frac{\sigma_1}{2}$  will represent the maximum shear stress. Hence criterion of failure is

$$\frac{\sigma_1}{2} = \pm \frac{\sigma_{yp}}{2} \text{ Ans.}$$

14. Buckling load for column with different end condition are :

$$P_E = \frac{\pi^2 EI}{L^2} \quad \dots \text{both ends hinged}$$

$$= \frac{\pi^2 EI}{4L^2} \quad \dots \text{one end is fixed (or clamped) other is hinged}$$

$$= \frac{2\pi^2 EI}{L^2} \quad \dots \text{one end is fixed (clamped) other is hinged}$$

$$= \frac{4\pi^2 EI}{L^2} \quad \dots \text{both ends fixed (or clamped)}$$

$\therefore$  When both ends are clamped, the buckling load is maximum.

15. The spring stiffness ( $k$ ) for a close-coiled helical spring in terms of dia. of wire ( $d$ ), mean radius of coil ( $R$ ), no. of turns ( $n$ ) and modulus of rigidity ( $c$ ) is given by

$$k = \frac{W}{\delta} = \frac{Cd^4}{64R^3 \times n}$$

When the dia. of wire ( $d$ ) and material of coil is same, then

$$k \propto \frac{1}{R^3 \times n} \quad \left[ \because \text{For the same material, } C \text{ is constant} \right]$$

$$\therefore k \times R^3 \times n = \text{constant}$$

or  $k_1 \times R_1^3 \times n_1 = k_2 \times R_2^3 \times n_2$

or

$$k_2 = k_1 \times \left(\frac{R_1}{R_2}\right)^3 \times \left(\frac{n_1}{n_2}\right) = k_1 \times \left(\frac{D_1}{D_2}\right)^3 \times \left(\frac{n_1}{n_2}\right)$$

$$= k_1 \times \left(\frac{75}{60}\right)^3 \times \left(\frac{8}{10}\right) \quad \left[ \begin{array}{l} \because D_1 = 75 \text{ mm}, n_1 = 8 \\ D_2 = 60 \text{ mm}, n_2 = 10 \end{array} \right]$$

$$= 1.56 k_1 \quad \text{Ans.}$$

∴ Answer is (c).

16. Here
- $d = 1 \text{ m} = 100 \text{ cm}$

$$p = 100 \text{ N/cm}^2$$

Max. permissible tensile stress =  $2 \text{ kN/cm}^2 = 2000 \text{ N/cm}^2$ 

For thin cylinder, the maximum stress is circumferential (or hoop) stress.

Hence here  $\sigma_c = 2000 \text{ N/cm}^2$ Let  $t =$  thickness.

$$\text{Then } \sigma_c = \frac{p \times d}{2t} \quad \left[ \text{Here } p \text{ and } \sigma_c \text{ should have same unit.} \right]$$

Then  $d$  and  $t$  will have the same unit

$$\text{or } t = \frac{p \times d}{2 \times \sigma_c} = \frac{100 \times 100}{2 \times 2000} = 2.5 \text{ cm} = 25 \text{ mm. Ans.}$$

17. Original volume,
- $V = \frac{\pi}{4} D^2 \times L$

Change in volume,  $dV$  will be obtained by taking differential as

$$dV = \frac{\pi}{4} D^2 \times dL + \frac{\pi}{4} L d(2D^2)$$

$$= \frac{\pi}{4} D^2 \times dL + \frac{\pi}{4} L \times 2D d(D)$$

$$\therefore \text{Volumetric strain, } \frac{dV}{V} = \frac{\frac{\pi}{4} D^2 \times dL + \frac{\pi}{4} L \times 2D \times d(D)}{\frac{\pi}{4} D^2 \times L}$$

$$= \frac{dL}{L} + \frac{2d(D)}{D}$$

$$\frac{dL}{L} = \text{Longitudinal strain} = e_2$$

$$\frac{d(D)}{D} = \text{Circumferential strain} \quad \left[ \frac{\pi(D + dD) - \pi D}{\pi D} = \frac{dD}{D} \right]$$

$$= e_1$$

$$\therefore \frac{dV}{V} = e_2 + 2e_1 = 2e_1 + e_2 \quad \left[ \frac{dV}{V} = \text{Change in volume per unit volume} \right]$$

18. The part which is cheapest in overall cost and can be easily replaced when there is some damage, is made the weakest part. The key in comparison to pulley and shaft can be replaced easily.

19. The shear stress distribution in a beam of rectangular cross-section is parabolic and having maximum value at the neutral axis. Hence the answer is (d).

Shear stress is given by

$$\tau = \frac{FA \times \bar{y}}{I \times b} \quad \text{where } A \times \bar{y} \text{ for rectangular section} = \frac{b}{2} \left( \frac{d^2}{4} - y^2 \right)$$

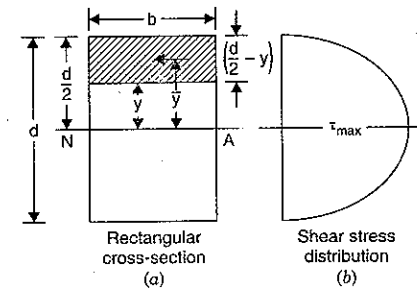

Fig. 14

where  $A =$  shaded area  $= b \times \left( \frac{d}{2} - y \right)$   
 $y =$  section where shear stress is  $\tau$

$\bar{y} =$  distance of C.G. of shaded area from N.A.  $= y + \frac{1}{2} \left( \frac{d}{2} - y \right)$

$I =$  M.O. Inertia

$b =$  width at section  $y$  which is  $b$  here.

$$\tau = \frac{F \times \frac{b}{2} \left( \frac{d^2}{4} - y^2 \right)}{I \times b} = \frac{F}{2I} \left( \frac{d^2}{4} - y^2 \right)$$

which is the equation of a parabola.

20. When beam is placed as shown in Fig. 15(a) 1st position, then bending stress is given by

$$\sigma_b = \frac{M}{I} \times y$$

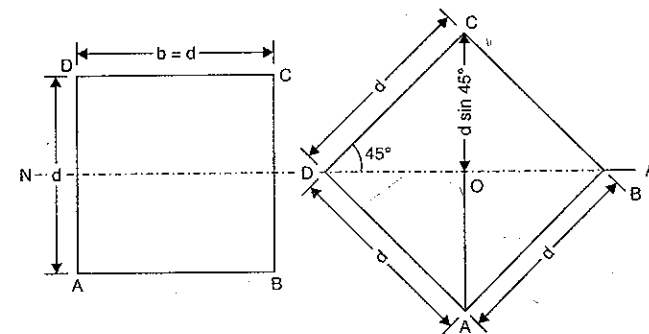

(a) 1st position

(b) 2nd position

Fig. 15

$$\text{and } (\sigma_b)_{\max} = \frac{M}{I} \times \frac{d}{2} = \frac{M}{\frac{bd^3}{12}} \times \frac{d}{2} \quad \left[ \because I = \frac{bd^3}{12} = \frac{d \times d^3}{12} = \frac{d^4}{12} \right]$$

$$= \frac{6M}{bd^2} = \frac{6M}{d \times d^2} = \frac{6M}{d^3} \quad (\because b = d \text{ being square}) \dots(i)$$

The bending stress when beam is placed as shown in Fig. 15(b) 2nd position is given by

$$(\sigma_b)^*_{\max} = \frac{M}{I^*} \times y^*$$

where  $y^*$  = Distance of top layer from

$$\begin{aligned} & \text{N.A. i.e., distance } OC \\ & = \text{half of diagonal of the square} = OC \\ & = d \times \sin 45^\circ = \frac{d}{\sqrt{2}} \end{aligned}$$

$I^*$  = M.O.I. of 2nd position about N.A.

$$= 2 \times \frac{bh^3}{12} \text{ where } b = BD = 2 \times \frac{d}{\sqrt{2}}$$

$$h = \frac{d}{\sqrt{2}} = \sqrt{2} \times d$$

$$= \frac{2 \times \sqrt{2}d \times \left(\frac{d}{\sqrt{2}}\right)^3}{12} = \frac{1}{6} \times \frac{d^4}{2} = \frac{d^4}{12}$$

$$\therefore \frac{(\sigma_b)^*_{\max}}{(\sigma_b)_{\max}} = \frac{\left(\frac{12M}{d^3 \times \sqrt{2}}\right)}{\left(\frac{6M}{d^3}\right)}$$

$$= \frac{2}{\sqrt{2}} = \sqrt{2}$$

$$\therefore (\sigma_b)^*_{\max} = \sqrt{2} \times (\sigma_b)_{\max}$$

Hence the answer is (c).

21.

$$\sigma_b = \frac{M}{I} \times y = \frac{M}{\frac{\pi}{64} \times d^4} \times \frac{d}{2} = \frac{32M}{\pi d^3}$$

$$T = \frac{\pi}{16} \times d^3 \times \tau$$

$$\tau = \frac{16T}{\pi d^3}$$

$$\therefore \frac{\sigma_b}{\tau} = \frac{32M}{\pi d^3} \times \frac{\pi d^3}{16T} = \frac{2M}{T} = 2. \quad (\because M = T)$$

22. For a simply supported beam carrying a point load at the centre the deflection ( $\delta$ ) is given by

$$\delta = \frac{PL^3}{48EI}$$

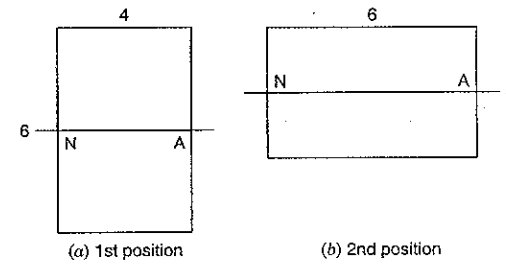

Fig. 16

Here load  $P$ , span of beam  $L$  and  $E$  is same for both positions,

$$\therefore \delta \propto \frac{1}{I} \quad \text{or} \quad \delta \times I = \text{constant}$$

$$\text{or} \quad \delta_1 \times I_1 = \delta_2 \times I_2 \quad \text{or} \quad \delta_2 = \delta_1 \times \frac{I_1}{I_2}$$

$$\text{Now} \quad I_1 = \frac{4 \times 6^3}{12} = 72$$

$$\text{and} \quad I_2 = \frac{6 \times 4^3}{12} = 32$$

$$\therefore \delta_2 = \delta_1 \times \frac{72}{32} = 2.25 \delta_1. \quad \text{Ans.}$$

Hence answer is (d).

23. Couple acting on beam =  $P \times C$  anti-clockwise moment at any point should be zero

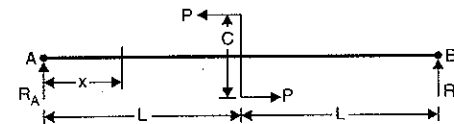

Fig. 17

$$\therefore M_A = 0$$

$$\text{or} \quad R_B \times 2L + P \times C = 0$$

$$\text{or} \quad R_B = \frac{-P \times C}{2L} \quad (\text{-ve sign shows that reaction } R_B \text{ is acting downwards)}$$

There is no load on the beam

$$\therefore R_A + R_B = 0 \quad \text{or} \quad R_A = -R_B = \frac{P \times C}{2L}$$

The reaction  $R_A$  is acting upwards.

$$\text{Shear force at } x, \quad F_x = R_A = \frac{P \times C}{2L}. \quad \text{Ans.}$$

24. Resolving forces along the inclined plane and normal to the plane, we get

$$P' \cos \alpha = \mu P_N + W \sin \alpha \quad \dots(1)$$

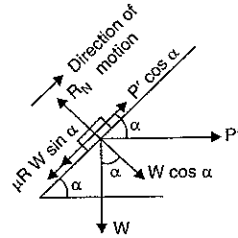

Fig. 18

$$R_N = W \cos \alpha + P' \sin \alpha \quad \dots(2)$$

Substituting the value of  $R_N$  in (1), we get

$$P' \cos \alpha = \mu[W \cos \alpha + P' \sin \alpha] + W \sin \alpha$$

Taking 
$$\mu = \tan \phi = \frac{\sin \phi}{\cos \phi}$$

and substituting in the above equation and simplifying, we get

$$P' = W \tan (\alpha + \phi)$$

$\therefore$  Frictional torque at mean radius ( $R$ ) is  $= R \times P' = R \times W \tan (\alpha + \phi)$ .

26.

$$\sigma_{\theta} = \frac{\sigma_x + \sigma_y}{2} + \frac{\sigma_x - \sigma_y}{2} \times \cos 2\theta$$

$$\begin{aligned} \sigma_{45} &= \frac{\sigma_x + \sigma_y}{2} + \frac{\sigma_x - \sigma_y}{2} \times \cos 90^\circ \\ &= \frac{\sigma_x + \sigma_y}{2} \\ &= \frac{5000 + 5000}{2} = 5000 \text{ N/cm}^2. \text{ Ans.} \end{aligned}$$

27. There is no normal stress either in  $x$ -direction or in  $y$ -direction.

$\therefore \sigma_x = 0$  and  $\sigma_y = 0$ . While drawing Mohr's circle of stresses,  $\sigma_x$  and  $\sigma_y$  are taken along  $x$ -axis from origin and shear stress ( $\tau$ ) along  $y$ -axis. Hence shear stress ( $\tau$ ) will be taken on the origin of axis along  $y$ -direction upward and downwards.

Hence answer is (c).

28.  $A = 1 \text{ cm}^2$ ;  $L = 100 \text{ cm}$ ;  $E = 20 \times 10^6 \text{ N/cm}^2$ ,  $P = 20 \text{ kN} = 20 \times 1000 \text{ N}$

$$\frac{\delta L}{L} = \frac{\sigma}{E} = \frac{\left(\frac{P}{A}\right)}{E}$$

$$\therefore \delta L = \frac{P}{AE} \times L = \frac{20,000 \times 100}{1 \times 20 \times 10^6} = 0.1 \text{ cm. Ans.}$$

$$29. A_1 = \pi r_1^2, A_2 = \pi \left(\frac{r_1}{2}\right)^2 = \frac{\pi r_1^2}{4}$$

The modulus of elasticity for a material is independent of area and load applied etc. Hence with the increase or decrease of area (i.e., radius), the modulus of elasticity will be unaffected. Ans.

30. To find the correct answer proceed as given below  
 Ductility is determined by tension test (3)  
 Toughness is determined by Impact test (1)  
 Endurance limit is determined by Fatigue Test (2)  
 Resistance to penetration is determined by Hardness test (4)  
 Hence the correct code is which contains 3, 1, 2, 4.  
 Hence the correct code is (c).

31.  $E = 21 \times 10^6 \text{ N/cm}^2$ ,  $C = 8 \times 10^6 \text{ N/cm}^2$   
 $E = 2C(1 + \mu)$   
 $\therefore \mu = \frac{E}{2C} - 1$   
 $= \frac{21 \times 10^6}{2 \times 8 \times 10^6} - 1 = \frac{21}{16} - 1 = 1.315 - 1 = 0.315. \text{ Ans.}$

32.  $P = 2\pi NT$ , where  $T = \frac{\pi}{16} \times d^3 \times \tau \therefore T_1 = \frac{\pi}{16} \times d_1^3 \times \tau$   
 $P_1 = 2\pi N_1 T_1$   $N_2 = \frac{N_1}{2}$   $T_2 = \frac{\pi}{6} \times (2d_1)^3 \times \tau$   
 $P_2 = 2\pi N_2 T_2$   $= \frac{\pi}{16} \times 8 \times d_1^3 \times \tau$   
 $= 2\pi \times \left(\frac{N_1}{2}\right) \times T_1$   $= 8 \times T_1$   
 $= 2\pi N_1 \times T_1 \times 4$   
 $= P_1 \times 4 = 90 \times 4 = 360 \text{ kW. Ans.}$

33. According to maximum shear stress theory for design purpose, we have the equation

$$(\sigma_1 - \sigma_2) = \sigma_t \text{ where } \sigma_t = \text{Permissible stress in simple tension}$$

or  $60 - (-60) = \sigma_t$  or  $60 + 60 = \sigma_t$

or  $\sigma_t = 120$  and safety factor  $= \frac{\sigma_t^*}{\sigma_t} = \frac{360}{120} = 3. \text{ Ans.}$

34. Here each rivet is subjected to direct stress due to load  $W$  and bending stress due to bending moment. Bending moment is equal to  $W \times e$  where  $e =$  eccentricity.

The value of  $e$  is maximum for rivets  $P$  and  $S$ . The direct stress is same for all the rivets, Bending stress is maximum when  $e$  is maximum. Eccentricity is maximum for rivets  $P$  and  $S$ . Hence rivets  $P$  and  $S$  are having maximum bending stress. Hence rivets  $P$  and  $S$  are most loaded. Ans.

35. The stiffness of a helical compression spring is given by,

$$k = \frac{Cd^4}{64 R^3 \times n}$$

where  $C =$  Modulus of rigidity  
 $d =$  dia. of wire  
 $n =$  no. of turns  
 $R =$  mean radius of coil.

When spring is cut into two equal halves, only no. of turns will be effected it will become half. Other value such as  $C$ ,  $d$  and  $R$  will be same.

$$\therefore k_2 = \frac{Cd^4}{64 \times R^3 \times \left(\frac{n}{2}\right)} = \frac{2Cd^4}{64R^3 \times n} = 2 \times k. \text{ Ans.}$$

36. For close-coiled helical spring,

$$\tau = \frac{16 WR}{\pi d^3}$$

While deriving this equation, the effect of curvature of spring and stress concentration effect are neglected. Hence the correct expression for shear stress will be

$$\tau = \frac{16 WR}{\pi d^3} \times K$$

where  $K$  = Wahl's correction factor

$$= \frac{4S-1}{4S-4} + \frac{0.615}{S}$$

where  $S$  = spring index =  $\frac{D}{d}$  =  $\frac{\text{mean dia. of coil}}{\text{dia. of wire}}$

37. Free body diagram through  $C$

$$R_1 + R_2 = 120 \text{ N} \quad \dots(i)$$

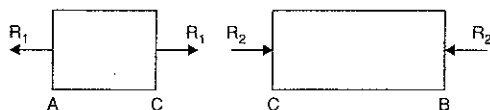
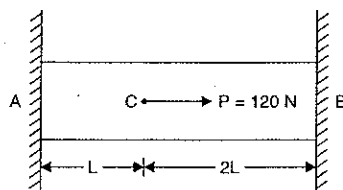

Fig. 19

Extension in  $AC$  = Compression in  $CB$

$$\text{For } AC: \frac{\delta L_1}{L_1} = \frac{\sigma_1}{E} \quad \text{or} \quad \delta L_1 = \frac{\sigma_1}{E} \times L_1 = \frac{R_1}{AE} \times L_1 \quad \left( \because \sigma_1 = \frac{R_1}{A} \right)$$

$$\text{For } CB: \frac{\delta L_2}{L_2} = \frac{\sigma_2}{E} \quad \text{or} \quad \delta L_2 = \frac{\sigma_2}{E} \times L_2 = \frac{R_2}{AE} \times L_2 \quad \left( \because \sigma_2 = \frac{R_2}{A} \right)$$

As  $\delta L_1 = \delta L_2$

$$\therefore \frac{R_1 \times L_1}{AE} = \frac{R_2 \times L_2}{AE}$$

or  $R_1 \times L_1 = R_2 \times L_2$  But  $L_1 = L$  and  $L_2 = 2L$

$$\therefore R_1 \times L = R_2 \times 2L$$

$$\text{or} \quad R_1 = 2R_2 \quad \dots(ii)$$

$$\text{From (i) and (ii), } 3R_2 = 120 \text{ N} \quad \therefore R_2 = 40 \text{ N. Ans.}$$

$$\text{and} \quad R_1 = 120 - 40 = 80 \text{ N. Ans.}$$

38.  $C = 100 \text{ GPa} = 100 \times 10^9 \text{ N/m}^2$

$$\mu = 0.25$$

$$E = 2C(1 + \mu)$$

$$= 2 \times 100 \times 10^9 (1 + 0.25)$$

$$= 200 \times 1.25 \times 10^9$$

$$= 250 \times 10^9 \text{ N/m}^2 = 250 \text{ GPa. Ans.}$$

39. Steel rod Aluminium rod

$$L_1 = 2 \text{ m}$$

$$L_2 = 1 \text{ m}$$

$$A_1 = 1 \text{ cm}^2$$

$$A_2 = 2 \text{ cm}^2$$

$$E_1 = 200 \text{ GPa}$$

$$E_2 = 100 \text{ GPa}$$

The rigid beam will be horizontal if:

Extension of steel rod = Extension of aluminium rod

$$\delta L_1 = \delta L_2$$

$$\frac{P_1 \times L_1}{A_1 \times E_1} = \frac{P_2 \times L_2}{A_2 \times E_2}$$

$$\text{or} \quad P_1 = P_2 \times \frac{A_1}{A_2} \times \frac{E_1}{E_2} \times \frac{L_2}{L_1} = P_2 \times \frac{1}{2} \times \frac{200}{100} \times \frac{1}{2} = \frac{P_2}{2}$$

$$\text{or} \quad 2P_1 = P_2 \quad \text{or} \quad P_2 = 2P_1. \text{ Ans.}$$

or load on aluminium rod = 2 times the load on steel rod.

40. Radial displacement =  $u$

$$\text{Initial radius} = r$$

$$\text{Final radius} = r + u$$

Tangential strain = Circumferential strain =  $\frac{\text{Final circumference} - \text{Initial}}{\text{Initial circumference}}$

$$= \frac{2\pi(r+u) - 2\pi r}{2\pi r} = \frac{2\pi u}{2\pi r} = \frac{u}{r}. \text{ Ans.}$$

41. Stiffness =  $\frac{\text{Load}}{\text{Deflection}} = \frac{P}{\text{Deflection under } P} \quad \dots(i)$

Let us find deflection under load  $P$ . This can be done by conjugate Beam Method. In this

method, the beam carries the  $\frac{M}{EI}$  load corresponding to actual load. The deflection at any section will be equal to B. M. at that section due the load carried by conjugate beam.

Refer to Fig. 20 (b).

Load for conjugate beam is  $\frac{M}{EI}$ .

B.M. at  $A = 0$ , hence value of  $\frac{M}{EI}$  at  $A = 0$

B.M. at  $C = P \times 2L$ , hence value of  $\frac{M}{EI}$  at  $C = \frac{P \times 2L}{E \times (2I)} = \frac{PL}{EI}$

B.M. at B =  $P \times L$ , hence value of  $\frac{M}{EI}$  at B for AB =  $\frac{P \times L}{EI}$  for BC =  $\frac{P \times L}{E \times (2I)} = \frac{PL}{2EI}$

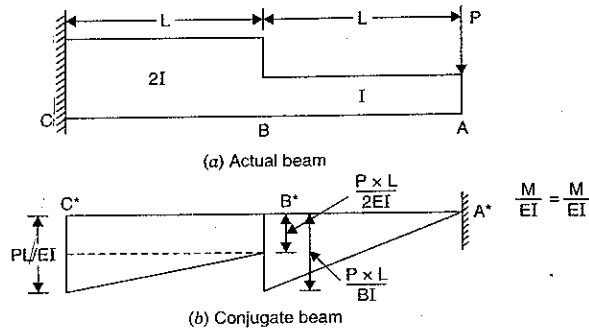

Fig. 20

Deflection ( $\delta$ ) at A = B.M. at A\* due to load carried by conjugate beam

$$= \left(\frac{1}{2} \times \frac{PL}{EI} \times L\right) \times \frac{2L}{3} + \left(\frac{PL}{2EI} \times L\right) \times 1.5L + \left(\frac{1}{2} \times \frac{PL}{2EI} \times L\right) \times \frac{5L}{3}$$

$$= \frac{PL^3}{EI} \left(\frac{1}{3} + 0.75 + \frac{5}{12}\right) = \frac{PL^3}{EI} \times \frac{18}{12} = \frac{1.5 \times PL^3}{EI}$$

$$\therefore \text{Stiffness} = \frac{P}{\delta} = \frac{P}{\left(\frac{1.5 \times PL^3}{EI}\right)} = \frac{EI}{1.5 \times L^3} = \frac{(200 \times 10^9) \times (375 \times 10^{-6})}{1.5 \times (0.5)^3}$$

$$= \frac{200 \times 10^9 \times 375 \times 10^{-4} \times 10^3}{1.5 \times 125} = 4 \times 10^{10} \text{ N/m. Ans.}$$

42. The maximum stress induced in a thin cylinder is hoop stress ( $\sigma_c$ ). It is given by

$$\sigma_c = \frac{p \times d}{2t}$$

The maximum hoop stress produced in spherical vessel =  $\frac{p \times d}{4t}$

$$\therefore \frac{\text{Max. stress in cylindrical vessel}}{\text{Max. stress in spherical vessel}} = \frac{\frac{pd}{2t}}{\frac{pd}{4t}} = 2.0.$$

44.

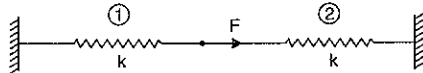

Fig. 21

Strain energy stored in spring 1,

$$U_1 = \frac{1}{2} \times F_1 \times \delta_1 \text{ where } F_1 = \text{force carried by spring 1}$$

$$= \frac{1}{2} \times \frac{F}{2} \times \frac{F}{2k}$$

$$= \frac{F^2}{8k} \text{ Ans.}$$

$$= \frac{F}{2} \text{ (}\because \text{ both springs are identical)}$$

$$\delta_1 = \text{Deflection of spring 1.}$$

$$= \frac{F_1}{k}$$

$$= \frac{F}{2k} \text{ (}\because F_1 = \frac{F}{2}\text{)}$$

45.  $A = 100 \times 10^{-6} \text{ m}^2$

Let  $P =$  tensile load at failure

$\therefore$  For one = dimensional stress system,

we have stresses as  $\left(\frac{P}{A}, 0, 0\right)$

Tensile stress due to load  $P, \sigma_1 = \frac{P}{A}$

This stress is in one-direction only i.e.,  $(\sigma, 0, 0)$

Max. shear stress due to stress system  $(\sigma_1, 0, 0) = \frac{1}{2} (\sigma_1 - 0) = \frac{\sigma_1}{2}$

Uniaxial yield stress,  $\sigma_t^* = 200 \text{ MPa} = 200 \times 10^6 \text{ N/m}^2$

$\therefore$  For uniaxial yield stress, we have stress system as  $(\sigma_t^*, 0, 0)$

Max. shear stress due to uniaxial yield stress =  $\frac{1}{2} (\sigma_t^* - 0) = \frac{\sigma_t^*}{2}$

According to Tresca failure criterion,

Max. shear stress developed = Max. shear due to yield stress

$$\text{i.e., } \frac{\sigma_1}{2} = \frac{\sigma_t^*}{2} \text{ or } \sigma_1 = \sigma_t^*$$

$$\text{or } \frac{P}{A} = 200 \times 10^6 \text{ N/m}^2 \text{ (}\because \sigma_t^* = 200 \times 10^6 \text{ N/m}^2 \text{ and } \sigma_1 = \frac{P}{A}\text{)}$$

$$\text{or } P = 200 \times 10^6 \times A$$

$$= (200 \times 10^6) \times (100 \times 10^{-6}) = 20000 = 20 \text{ kN. Ans.}$$

46. We know that stiffness of a close-coiled helical spring is given by

$$k = \frac{Cd^4}{64 R^3 \times n}$$

$$\text{1st case, } k_1 = \frac{Cd^4}{64 \left(\frac{D}{2}\right)^3 \times N} \text{ (here } R = \frac{D}{2} \text{ and } n = N\text{)}$$

$$\text{2nd case, } k_2 = \frac{C(2d)^4}{64 \left(\frac{2D}{2}\right)^3 \times 2N}$$

(here dia. of wire =  $2d$ ; Mean coil dia. =  $2D$  and number of turns =  $2N$ )

$$= \frac{Cd^4 \times 16}{64 \times \left(\frac{D}{2}\right)^3 \times 8 \times 2N} = \frac{Cd^4}{64 \left(\frac{D}{2}\right) \times N} = k_1 \quad \left( \because k_1 = \frac{Cd^4}{64 \left(\frac{D}{2}\right)^3 \times N} \right) \text{ Ans.}$$

47. Euler's buckling load,

$P = \frac{\pi^2 EI}{L^2}$  where  $I = \frac{\pi}{64} d^4$  For circular column when diameter is reduced by 20%, then dia. of new column = 0.8 d

$$\therefore \text{New moment of inertia, } I^* = \frac{\pi}{4} \times (0.8 d)^4 = \frac{\pi}{4} \times d^4 \times (0.8)^4$$

$$\text{Initial buckling load, } P = \frac{\pi^2 E}{L^2} \times \frac{\pi}{64} d^4$$

$$\text{New buckling load, } P^* = \frac{\pi^2 E}{L^2} \times \frac{\pi}{64} \times d^4 \times 0.8^4$$

$$\therefore \% \text{ reduction in load} = \frac{P - P^*}{P} \times 100 = \left( \frac{\frac{\pi^2 E}{L^2} \times \frac{\pi}{64} d^4 - \frac{\pi^2 E}{L^2} \times \frac{\pi}{64} d^4 \times 0.8^4}{\frac{\pi^2 E}{L^2} \times \frac{\pi}{64} d^4} \right) \times 100 = \frac{1 - 0.8^4}{1} = (1 - 0.4096) \times 100 = 59\% \text{ Ans.}$$

48. For a column of one end fixed and other free, the buckling load is

$$P_1 = \frac{\pi^2 EI}{4L^2}$$

For a second column of same length and same cross-sectional area when both ends are fixed, the buckling load is

$$P_2 = \frac{4\pi^2 EI}{L^2}$$

$$\therefore \frac{P_2}{P_1} = \frac{\left(\frac{4\pi^2 EI}{L^2}\right)}{\left(\frac{\pi^2 EI}{4L^2}\right)} = 4 \times 4 = 16 \text{ Ans.}$$

49.  $\sigma_{\max} = \frac{1}{2} [\sigma_1 - \sigma_3] = \frac{1}{2} [80 - (-40)] = 60 \text{ MPa. Ans.}$

50.  $E = 2C(1 + \mu)$

$$\therefore \mu = \frac{E}{2C} - 1 = \frac{120}{2 \times 50} - 1 = 1.2 - 1.0 = 0.2 \text{ Ans.}$$

## Subject Index

### A

- Analysis of bars of varying sections, 14
  - of composite sections, 30
- Analysis of a compound weld, 905
- Area moment method, 546
- Assumptions made in the theory of simple bending, 293

### B

- Bar of uniform strength, 51
  - composite sections, 30
  - varying sections, 14
- Beams, continuous, 652
  - fixed, 613
  - deflection of beams, 511
  - propped, 609
  - columns, 858
- Bending, 292
  - plane, 293
  - moment, 235
  - moment and shear force, 235
  - stresses in beams, 292
  - of curved bars, 957

- Bulk modulus, 70
- Buckling load, 810
- Butt joint, 871
  - weld, 901

### C

- Cantilever, 239
  - propped, 597
  - truss, 478
- Centre of gravity, 170
- Circumferential stress, 741
- Centroid, 170
- Chain riveting, 872

- Chimneys, 458
  - wind pressure, 458
- Clapeyron's equation, 653
- Columns and struts, 808
  - long, 808
  - beams, 858
  - with eccentric load, 849
  - with initial curvature, 853
- Combined direct and bending, 377
- Composite shaft, 706
- Composite sections, 30
- Combined bending and torsion, 710
- Complementary shear stresses, 73
- Compressive stress, 3
  - strain, 3
- Conjugate beam method, 578
- Continuous beams, 652
- Coupling, 695
- Critical load, 810
- Curved bars, 957
  - Rectangular, 965
  - Triangular, 966
  - Circular, 969
  - Trapezoidal, 968
- Cylinders, thin, 740
  - thick, 781

### D

- Dam, 409
- Deflection of beams, 511
  - of cantilever, 554
- Design of columns, 820
  - thick cylindrical shell, 781
  - riveted joint, 892
- Diamond riveting, 872
- Direct and bending stress combined, 377
- Disc with uniform strength, 936



**E**

- Earth pressure, 443
- Eccentric load, 378
- Eccentricity, limit of, 398
- Elasticity, 5
- Elastic constants, 59
- Elastic limit, 5
- Elastic moduli, 6
- Elongation due to self weight, 50
- Efficiency of a joint, 746, 880
- Energy of distortion, 1033
- Effective length, 818
- Euler's theory, 809
  - limitations of, 820

**F**

- Factor of safety, 6, 848
- Failure of a column, 808
- Failure of riveted joints, 876
- Fixed beams, 613
- Formula—Johnson's, 847
  - I.S.C., 848
  - straight line, 847
- Frames, 465
- Flanged coupling, 695

**G**

- Gordon's formula, 838
- Gradual loading, 143
- Graphical method, 498
  - principal stresses, 85
- Guest's theory, 1010
- Gyration, radius, 195

**H**

- Haigh's theory, 1014
- Helical springs, 724
- Hooke's Law, 6
- Hoop stress, 741

**I**

- Impact loading, 143
  - load, 152

- Inclined loads, 279
- I-section, 356

**J**

- Johnson's formula, 847
- Joints : riveted, 871
  - welded, 900

**K**

- Kernal, 401
  - of hollow circular section, 401
  - of hollow rectangular section, 402

**L**

- Lap joint, 871
  - weld, 902
- Lateral strain, 59
- Leaf springs, 721
- Long columns, 808
- Longitudinal strain, 59
  - stress, 742

**M**

- Macaulay's method, 531
- Maximum principal stress theory, 1005
  - strain theory, 1006
  - shear stress theory, 1010
  - strain energy theory, 1014
  - shear strain energy theory, 1018
- Middle third rule, 398
- Middle quarter rule, 400
- Mises-Henky theory, 1018
- Method of joints, 467
  - sections, 488
- Modulus, bulk, 70
  - of elasticity, 6
  - of rigidity, 6
- Mohr's circle, 128
- Mohr's theorem, 548
- Moment area method, 546
- Moment of inertia, 194
  - resistance, 295

**N**

- Neutral axis, 295
  - layer, 295

**O**

- Oblique, 85
- Overhanging beams, 236

**P**

- Pitch of rivets, 871
- Poisson's ratio, 60
- Polar moment of inertia, 687
- Polar Modulus, 688
- Power transmitted by shafts, 677
- Principal planes, 85
  - Strain, 85
  - Stress, 85
- Principle of complementary shear stresses, 73
- Proof resilience, 143
- Propped cantilevers and beams, 578

**R**

- Rankine's formula, 835
- Rankine theory, 516, 1006
- Relationship between modulus of elasticity, 79
  - S.F. and B.M. 287
- Resilience, 143
  - proof, 143
- Resistance of moment, 295
- Riveted joints, 871
  - failure, 876
  - strength, 879
  - efficiency, 880
  - design, 892
- Rotational stress, 919
  - in a thin cylinder, 773, 919
  - in a thin disc, 919
  - in a solid cylinder, 944
  - Hollow cylinder, 940

**S**

- Safety factor, 6
- Saint-Venant theory, 1006

- Simple bending, 294
- Section modulus, 300
- Shafts, torsion of, 672
- Shafts, compound and composite, 706
- Shear force diagram, 235
  - for cantilevers, 239
  - for a simply supported beam, 252
- Shear strain energy, 1033
- Shear modulus, 6
- Spherical shells, 771
- Springs : Laminated, 721
  - helical, 724
- Straight line formula, 847
- Strain, 2
  - types, 2
  - compressive, 2
  - shear, 2
  - tensile, 2
- Strain energy due to torsion, 713
- Strain energy, 143
- Stress, 1
  - in a curved bar, 957
  - compressive, 3
  - shear, 4
  - principal, 86
  - tensile, 2
  - thermal, 42
- Stress due to rotation stresses in a hook, 978
  - in a simple chain link, 993
  - in a curved plate, 957
  - in a circular ring, 987
- Strength of a shaft, 688
  - rivetted joint, 879
- Struts, 808
  - with lateral load, 858

**T**

- Thermal stresses, 42
- Tensile, 2
  - strain, 2
  - stress, 2
- Thick cylinder, 781
- Thick spherical shells, 809

- Thick sphere, 781
- Thin cylinder, 740
  - spherical shells, 770
- Theorem of
  - parallel axis, 196
  - perpendicular axis, 195
- Theories of failure, 1005
- Theory of
  - maximum principal stress, 1005
  - maximum strain, 1006
  - maximum shear stress, 1010
  - maximum strain energy, 1014
  - maximum shear strain energy, 1018
- Torque by a
  - solid shaft, 674
  - hollow shaft, 676
- Torsion of shafts, 672
- Torsion of tapering shafts, 716
- Torsional rigidity, 688
- Types of riveted joints, 871
  - welded joints, 901
  - beam, 235
  - load, 236

- Ultimate strength, 8
- Uniform strength, 51
- Unwin's formula, 892
- Unsymmetrical bending, 312

**V**

- Value of  $h^2$  for curved
  - rectangular bar, 965
  - triangular bar, 966
  - circular bar, 969
  - trapezoidal bar, 968
- Volumetric strain, 62
- V-butt joint, 901
- Vibrations, 805

**W**

- Walls retaining, 443
- Water and earth pressure, 409
- Welded joints, 900
  - butt weld joint, 901
  - fillet weld joint, 901
  - compound weld joint, 905
- Wire wound pipes, 765
- Winkler-Bach Formula, 964
- Wind pressure on chimneys, 461

**Y**

- Yield points, 7
- Yield strength, 1005
- Young's modulus, 6, 59

**Z**

- Zig-Zag riveted joint, 872

### About the Book

The fourth edition of this book '**A Textbook of Strength of Materials**' contains twenty five chapters. This edition has been thoroughly revised and made up-to-date. A large number of numerical problems from different B.E. degree examinations have been added with solution at proper places. At the end of each chapter, highlights, theoretical questions and many unsolved numerical problems with answers have been given for the students to practice them. Three advanced topics – stresses due to rotation in thin and thick cylinders, bending of curved bars and theories of failures of the materials have also been added. These chapters have been written in such a simple and easy-to-follow language that even an average student can understand them easily by self-study. A large number of Objective Type Multiple Choice Questions, asked in the most of the competitive examinations, have been incorporated in this edition with answers and explanations to make this edition more useful for competitive examinations.

### Author's Profile

**Dr. R.K. Bansal** graduated in 1966. He obtained his Master's Degree in 1975 with '**HONOURS**' from I. I. T., Delhi and Ph.D. in 1981 from University of Delhi. He joined Delhi College of Engineering as a Lecturer and became Assistant Professor in 1984. He was selected for the post of Professor in 1995. He also held the posts of Head of Mech. Engineering (Faculty of Technology, University of Delhi), Dean (P.G.) Studies and Dean (U.G.) Studies, Delhi College of Engineering, Delhi. During his teaching career of about thirty five years, he guided a large number of research students and got published many papers. Dr. Bansal is the author of many books, which are followed as textbooks.



**LAXMI PUBLICATIONS (P) LTD**

