



Civinnovate

Discover, Learn, and Innovate in Civil Engineering

**TRIBHUVAN UNIVERSITY
INSTITUTE OF ENGINEERING
PULCHOWK CAMPUS**

(Pulchowk, Lalitpur)

Subject: Strength of Materials(II/I)

(Tutorial)

1.Axial Force, Shear Force and Bending Moment:

1. Draw AFD, SFD and BMD for following determinate structural components.

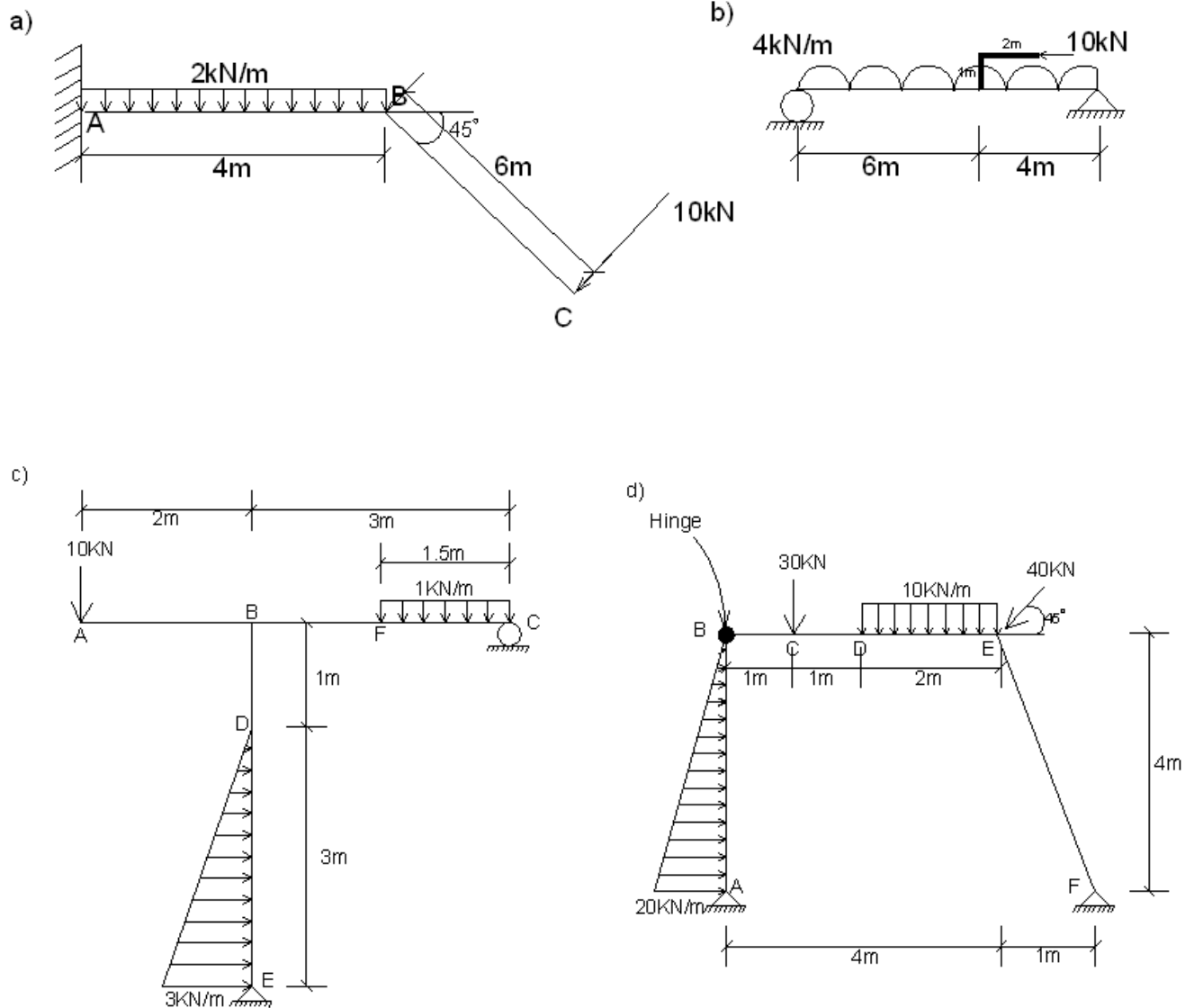

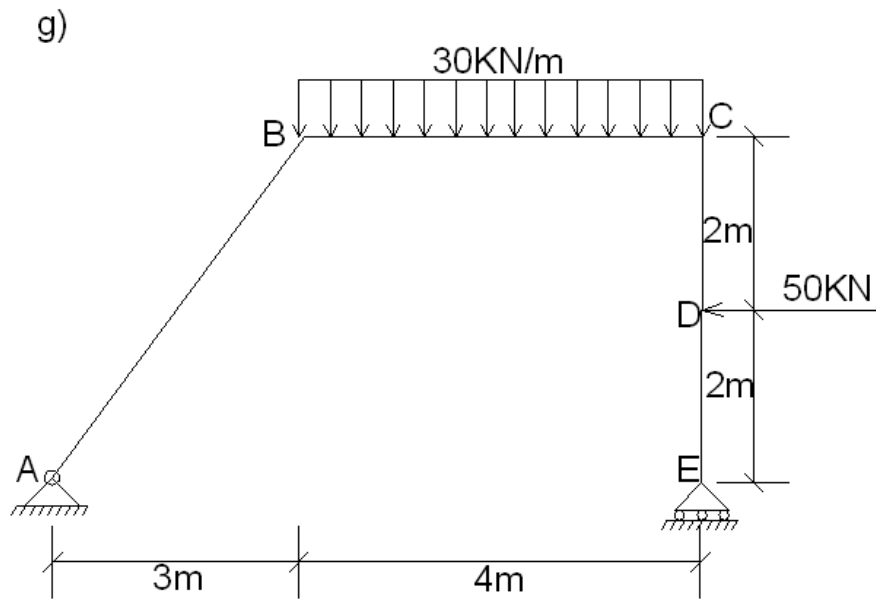
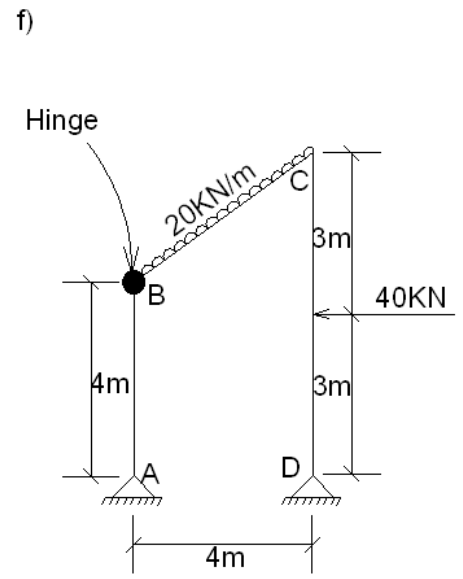
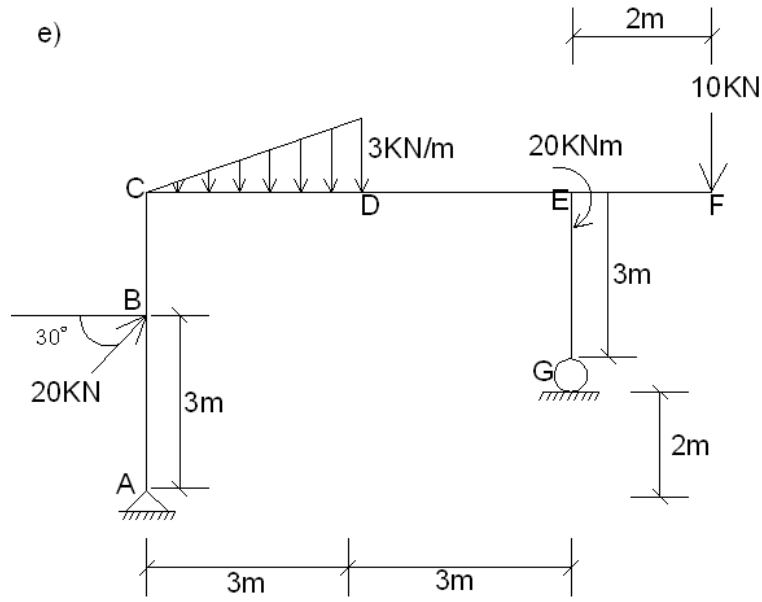

2. Geometrical Properties of Sections:

1. Find the orientation of principal axes and the principal moments of inertia about axes through centroid of the given figures. (Also verify your result with Mohr's circle for any two among following.)

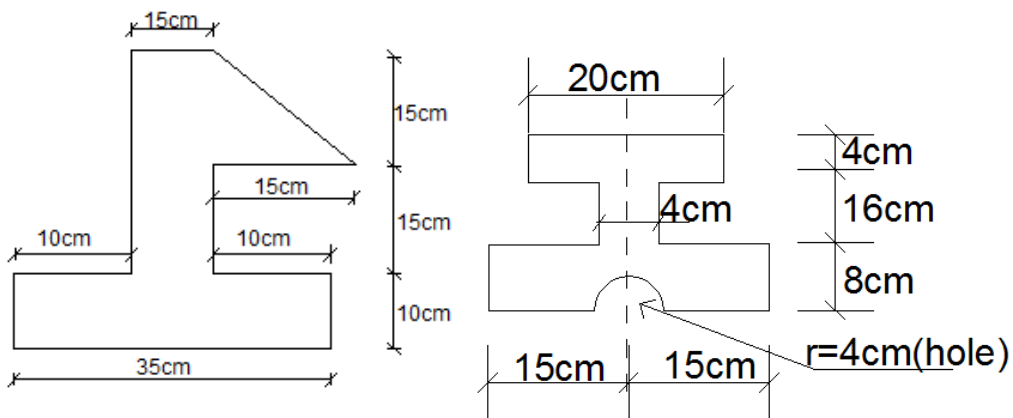
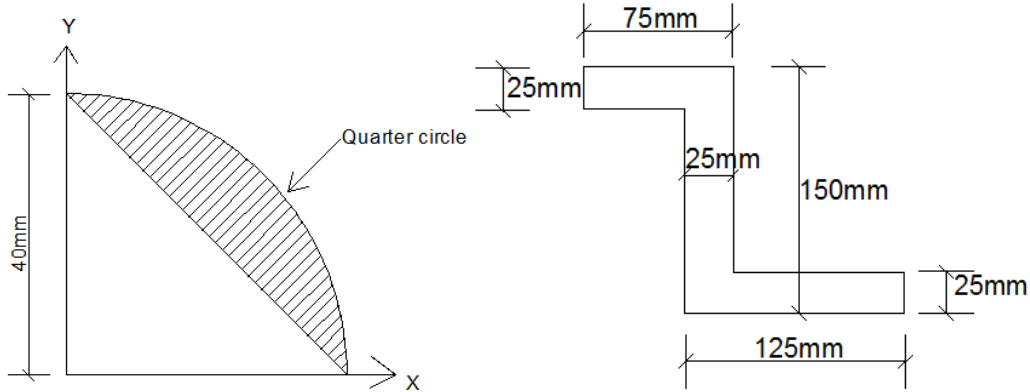

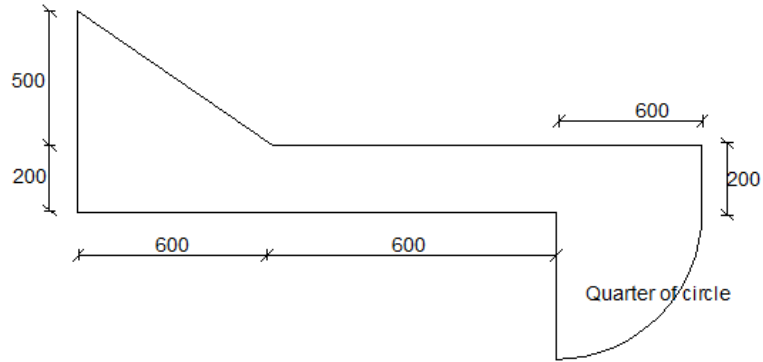

3.Simple Stress and strain:

1. A steel bar of varying cross sections is subjected to axial forces shown in figure 1. Find the value of P to keep the system in equilibrium. Take $E=210 \text{ KN/mm}^2$. Calculate the total elongation of bar. (Ans: 1.632mm)

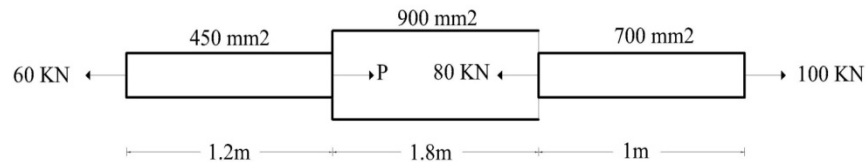

Fig-1

2. A solid conical bar tapers uniformly from a diameter of 8cm to 3 cm in length of 100cm. It is suspended vertically at 8cm diameter, 3cm diameter being downward. Calculate elongation of bar due to self weight. Take unit weight of the bar 78.5 KN/m^3 and $E=210 \text{ KN/mm}^2$. (Ans: $1.0903 \times 10^{-4} \text{ mm}$)
3. A rigid bar AB hinged to a vertical wall and supported horizontally by tie rod CD as shown in fig 2. The tie bar has cross sectional area 0.5 cm^2 and its allowable stress in tension is 1500 kg/cm^2 . Find the safe value of P and the vertical deflection of point A. Take E for tie bar $2 \times 10^6 \text{ kg/cm}^2$. (Ans: 225kg, 6.25mm)

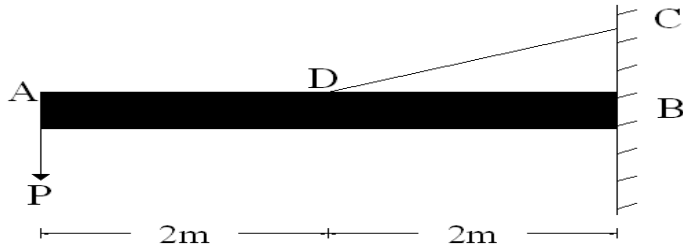
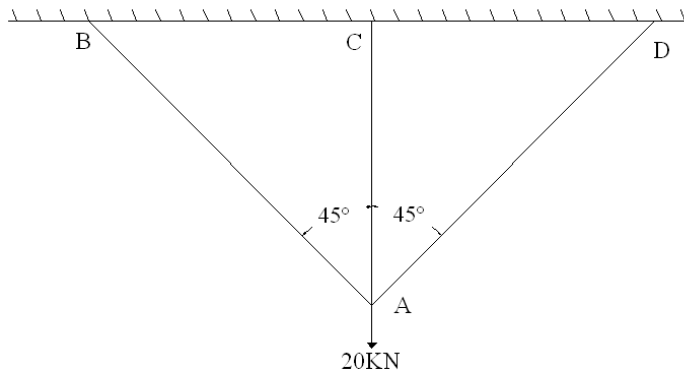

Fig-2

4. A 8m long hollow circular bar of aluminum carries a tensile load of 120KN. The outside diameter of the bar is 50mm and modulus of elasticity of the material is $70 \times 10^3 \text{Mpa}$. If the allowable elongation of the bar is 10mm, determine the minimum thickness. (Ans:11.272mm)
5. A system of bars is loaded as shown in figure 3. Find the axial load in each bar due to 20KN load. All bars are of steel. (Ans: 5.858, 5.858, 11.716kN)



6. A compound tube consists of a steel tube 15cm internal diameter and 1cm thickness. The two tubes are of same length. The compound tube carries an axial load of 1000 KN. Find the stresses and load carried by each tube and the amount by which it shortens. Length of each tube is 150cm. Take $E_s = 2 \times 10^7 \text{ N/cm}^2$. & $E_b = 1 \times 10^7 \text{ N/cm}^2$. (Ans: 639.9, 360.1kN, 0.95mm)
7. A horizontal rigid bar AB is hinged to a vertical wall at A and supported by two wires BD and CD and the strut EC as shown in figure 4. Each wire has cross-sectional area of 0.7 cm^2 and working stress 3000 kg/cm^2 . The strut has a buckling strength of 1500kg in compression. Calculate the safe load P for the system. (Ans: 1628.2kg)

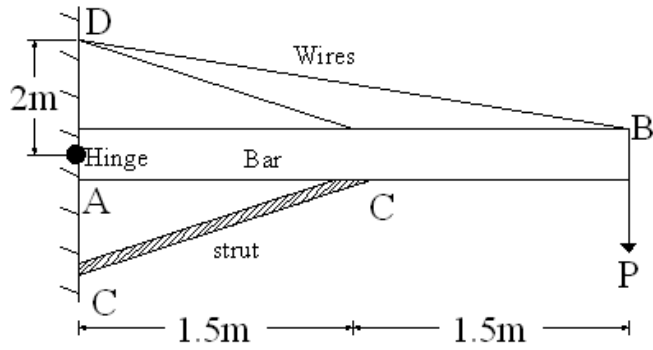

Fig-4

8. Two copper rods and one steel rod together support a load as shown in fig 5. If the stresses in the copper and steel are not to be exceeded by 550 kg/cm^2 and 1000 kg/cm^2 respectively, determine the safe load that can be applied. Cross section for copper = $3 \times 3 \text{ cm}^2$, steel = $4 \times 4 \text{ cm}^2$. Take $E_s = 2E_c$. (Ans: $P = 20460 \text{ kg}$)

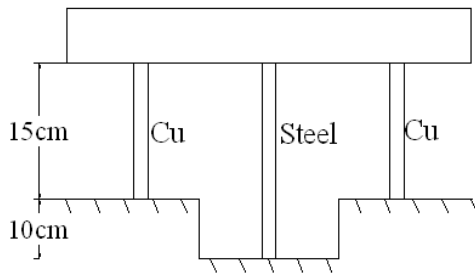
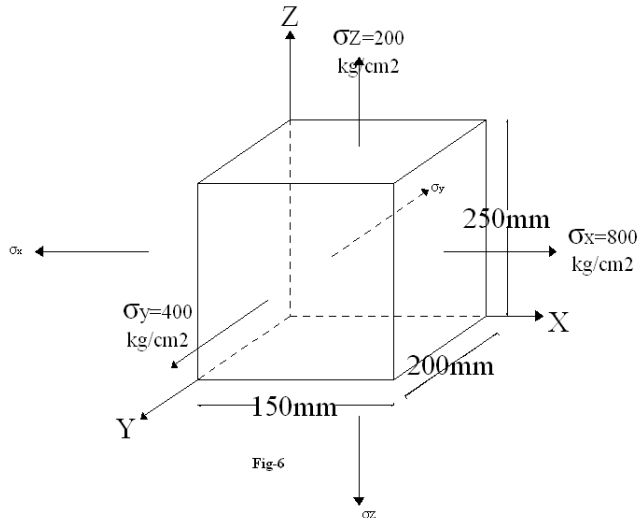

Fig-5

9. A block of steel ($150 \times 200 \times 250$) mm is subjected to axial stress as shown in figure 6. Find the change in dimensions of block and change in volume. Also find G & K. Take $E_s = 200 \text{ GN/m}^2$ and $\mu = 0.30$. (Ans: 0.0465 mm , 0.01 mm , -0.02 mm , 2100 mm^3)



10. An aluminum bar 3m long and having 20cm^2 cross sectional area is loaded as shown in fig 7. Determine the stresses in the portions AB, BC and CD. Also find the distance through which point B and C will move. Take $E=0.7 \times 10^6 \text{ kg/cm}^2$. (Ans: 33.33kg/cm^2 , 8.33kg/cm^2 , -41.67kg/cm^2)

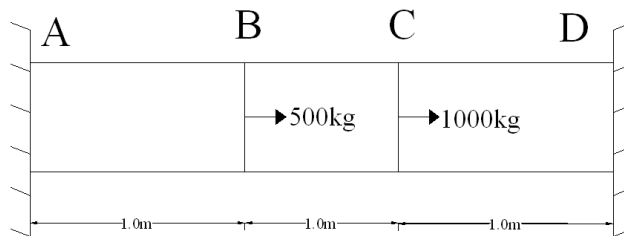

Fig-7

11. The modulus of rigidity for a material is $0.5 \times 10^5 \text{ N/mm}^2$. A 10mm diameter rod of the material was subjected to an axial pull of 10KN and the change of diameter was observed to be $3 \times 10^{-3} \text{ mm}$. calculate the Poisson's ratio and the modulus of elasticity.
12. A vertical rod of length 3m tapers uniformly from diameter of 80mm at top to 40mm at the bottom. If it is rigidly fixed at the upper end and is subjected to the axial load of 45KN, determine the total extension in the bar. Take density of material $= 2 \times 10^5 \text{ kg/m}^3$ and Young's modulus $= 210\text{Gpa}$

13. A rigid bar AB is hinged at A and supported by 2m long copper rod and a 4m long steel rod. It carries a load of 100kN at the free end B as shown in figure below. If the area of cross section of steel and copper rods are 10cm^2 and 8cm^2 respectively and their respective values of E be 200Gpa and 100Gpa, find the stress in each rod and reaction at A (Assume no bending in Steel and copper rods).

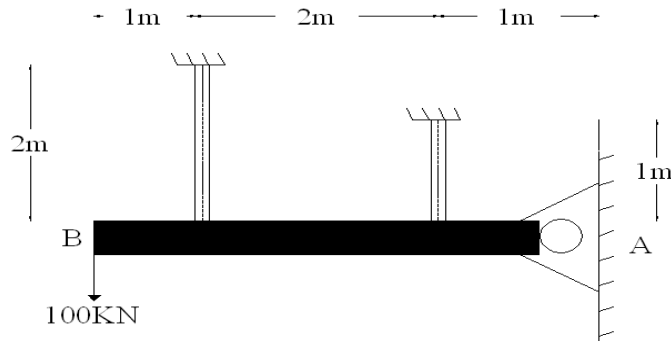

Fig-2

14. A steel bar 2.5cm diameter and 25 cm long was subjected to a tension test. On applying a tensile load of 25 KN the elongation was found to be 0.005cm and decrease in diameter was 0.00025cm. calculate the value of:
- Modulus of Elasticity
 - Poisson's ratio
 - Change in Volume
 - Shear Modulus
15. Determine the maximum permissible load if the compressive stress in the rod is not to exceed 110 Mpa and that of tube is not to exceed 80 Mpa. Take $E_s=200$ Gpa and $E_b=100$ Gpa.

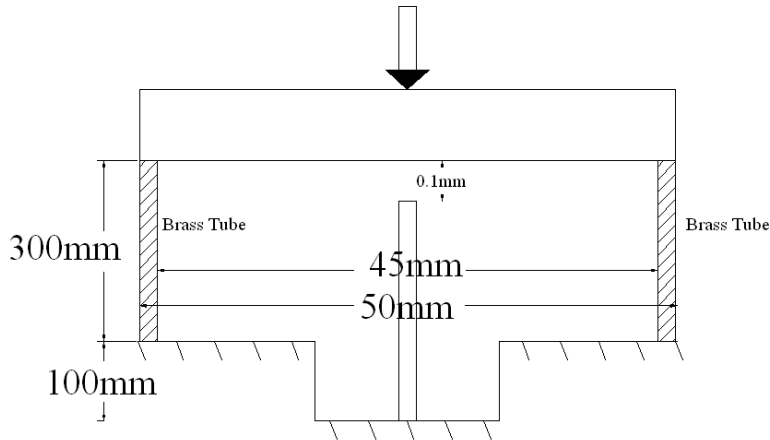
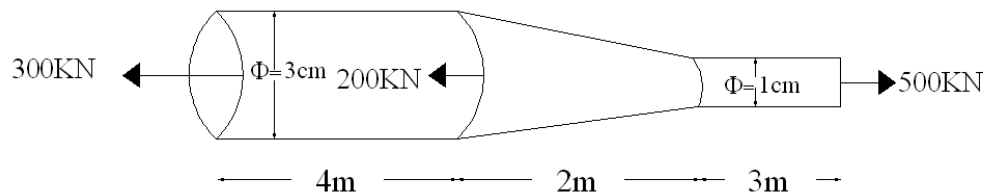

Fig-5

16. Determine the elongation of the bar as shown in figure. Take $E=2 \times 10^5 \text{ N/mm}^2$



4. Stress and Strain Analysis:

1. A plane element is subjected to the stresses as shown in following figure. Determine analytically and graphically

- The principal stresses and their directions. (Ans: 7.708 MPa , -142.708 MPa , -34.27° , 55.73°)
- The maximum shearing stresses and the directions of the planes on which they act. (Ans: 75.208 MPa , 10.724°)

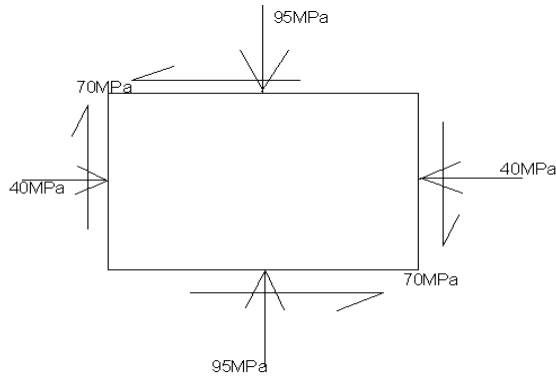

fig 4.1

2. The magnitude and direction of the stresses on two planes intersecting at a point area shown in figure 4.2. Determine the direction and magnitude of the principal stresses at this point. Sketch the result on an element. (Ans : 5.154P)

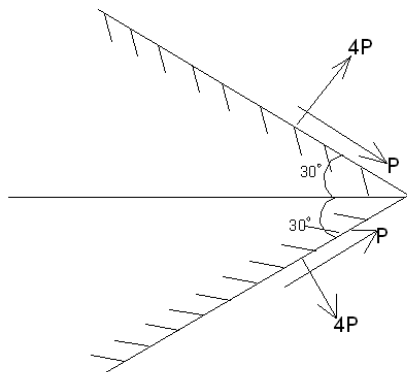

fig 4.2

3. At point A on an unloaded edge of an elastic body, oriented as shown in fig 4.3 with respect to XY axis, the maximum shearing stress is 2900 kN/m^2 . Find the principal stresses. (Ans: $5.73P$, $3.423P$)

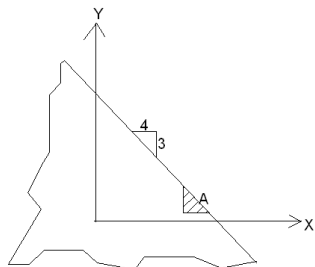

fig 4.3

4. The state of stress in two dimensionally stressed body is as shown in fig4.4. Find magnitude and direction of principal stresses and maximum shear stress. Also determine the normal and tangential stresses on plane AC. Verify results using Mohr's Circle.

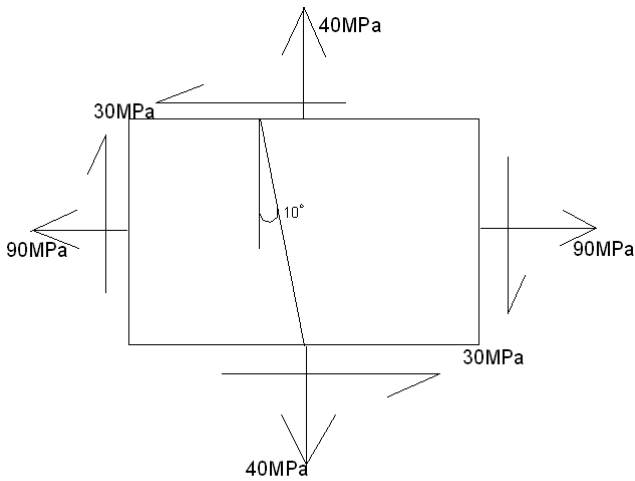

fig 4.4

5. The state of stress in two dimensionally stressed body is as shown in fig4.5. Find magnitude and direction of principal stresses and maximum shear stress. Also determine the normal and tangential stresses on the plane AC. Verify results using Mohr's Circle.

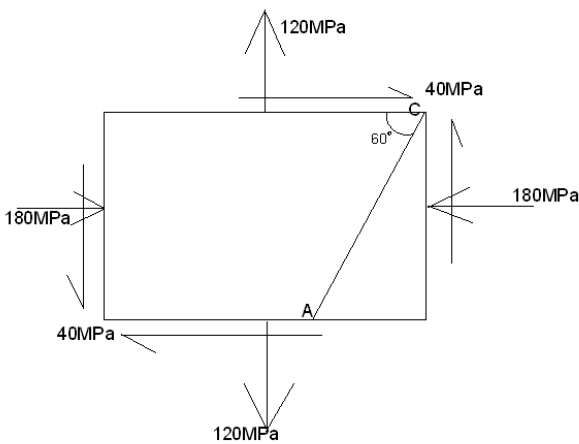

fig 4.5

5.Thin Walled Vessels:

1 A gas cylinder of internal diameter 40mm is 5 mm thick. If the tensile stress in the material is not to exceed 30MPa, find the maximum pressure which can be allowed in the cylinder? (Ans: 7.5MPa)

2. A cylindrical shell of 500 mm diameter is required to withstand an internal pressure of 4MPa. Find the minimum thickness of the shell, if the maximum tensile strength in the plate material is 400MPa and efficiency of the joints is 65%. Take factor of safety as 5. (Ans: 20mm)
3. A cylindrical thin drum 800mm in diameter and 4m long is made up of 10mm thick plates. If the drum is subjected to an internal pressure of 2.5MPa, determine its change in diameter and length. Take E as 200GPa and Poisson's ratio as 0.25. (Ans: 0.35, 0.5)
4. A cylindrical vessel 2 m long and 500mm diameter with 10 mm thick plates is subjected to an internal pressure of 3MPa. Calculate the change in volume of the vessel. Take $E=200\text{GPa}$ and Poisson's ratio=0.3 for the vessel material. (Ans: $185 \times 10^3 \text{mm}^3$)
5. A steam boiler of 1.25 m in diameter is subjected to an internal pressure of 1.6MPa. If the steam boiler is made up of 20mm thick plates, calculate the circumferential and longitudinal stresses. Take the efficiency of the circumferential and longitudinal joints as 75% and 60% respectively. (Ans: 67MPa , 42MPa)
6. A thin cylindrical shell is 4m long and has 1m internal diameter and 12mm metal thickness. Calculate the maximum intensity of shear stress induced and change in dimensions of the shell if it is subjected to an internal pressure of 2N/mm^2 . Take $E=2 \times 10^5 \text{N/mm}^2$ and $\mu=0.3$.
7. A thin cylindrical shell made up of copper plate has been filled with a liquid at atmospheric pressure. Length (l)=2m, external diameter (D)=30cm, $t=10\text{mm}$, $E=1.04 \times 10^6 \text{kg/cm}^2$, $\mu=0.32$. Find the values of pressure developed by the liquid on the wall of the cylinder and the hoop stress developed if an additional 35cm^3 of the liquid is pumped into the cylinder. (Ans: 11.34kg/cm^2 , 158.76kg/cm^2)
8. A seamless spherical vessel of 2m internal diameter and 6mm thick is filled with a fluid under pressure until its volume increase by 300cm^3 . Calculate the pressure exerted by fluid on the vessel. Take $E=2.1 \times 10^5 \text{N/mm}^2$, $\mu=0.3$. (Ans: 0.0857N/mm^2)
9. A copper plate vessel in the shape of thin spherical shell 50cm radius and 1cm shell thickness is completely filled with a fluid at atmospheric pressure. Additional fluid is then pumped till the pressure increased by 10MN/m^2 . Find the volume of this additional fluid, given that $\mu=0.26$ and $E=100\text{GN/m}^2$ for the shell material. (2906cm^3)

6.Torsion:

1. A solid circular shaft of 100mm diameter is transmitting 120kW at 150 r.p.m. Find the intensity of shear stress in the shaft. (Ans: 39Mpa)
2. A hollow shaft is to transmit 200kW at 80 r.p.m. If the shear stress is not to exceed 60MPa and internal diameter is 0.6 of the external diameter, find the diameters of the shaft. . (Ans: 132mm, 79.2mm)
3. A solid steel shaft has to transmit 100kW at 160 r.p.m. Taking allowable shear stress as 70 MPa, find the suitable diameter of the shaft. The maximum torque transmitted in each revolution exceeds the mean by 20%. (Ans: 80mm)
4. Find the angle of twist per meter length of a hollow shaft of 100mm external and 60mm internal diameter, if the shear stress is not to exceed 35MPa. Take $C=85\text{GPa}$. (0.5°)
5. Find the maximum torque that can be safely applied to a shaft of 80mm diameter. The permissible angle of twist is 1.5 degree in a length of 5m and shear stress not to exceed 42MPa. Take $C=84\text{GPa}$. (Ans: $1.77 \times 10^6 \text{N}\cdot\text{mm}$)
6. A solid shaft is subjected to a torque of 1.6 kN-m. Find the necessary diameter of the shaft, if the allowable shear stress is 60MPa. The allowable twist is 1° for every 20 diameters length of the shaft. Take $C=80\text{GPa}$. (Ans: 61.6mm)
7. A solid shaft of 200mm diameter has the same cross sectional area as a hollow shaft of same material with inside diameter of 150mm. Find the ratio of
 - (a) powers transmitted by both the shafts at the same angular velocity.
 - (b) angles of twist in equal lengths of these shafts, when stressed to the same intensity.(Ans: 1.7, 0.8)
8. A solid steel shaft of 60mm diameter is to be replaced by a hollow steel shaft of the same material with internal diameter equal to half of the external diameter. Find the diameters of the hollow shaft and saving in material, if the maximum allowable shear stress is same for both the shafts. (Ans: 61.3mm, 30.65mm, 21.7%)
9. A solid aluminum shaft 1m long and of 50mm diameter is to be replaced by a hollow shaft of the same length and same outside diameter, so that the hollow shaft could carry the same torque and has the same angle of twist. What must be the inner diameter of the hollow shaft? Take modulus of rigidity for the aluminum as 28GPa and that for steel as 85GPa. (Ans: 45.25mm)
10. A composite shaft consists of steel rod of 60mm diameter surrounded by a closely fitting tube of brass. Find the outside diameter of brass tube, when a torque of 1KN-m is applied on the composite shaft and shared equally by the two materials. Take C for steel as 84GPa and C for brass as 42GPa. Also determine the common angle of twist in a length of 4m. (Ans: 79mm, 1.07°)

11. A solid steel shaft 6m long is fixed at each ends. A torque of 2KN-m is applied to the shaft at a section 2.6m from one end. What are the fixing torques's set up at the ends of the shaft? If the diameter of the shaft is 40mm, what are the maximum shearing stresses in the two portions? Calculate also the angle of twist for the section where the torque is applied. Take $G=84\text{GN/m}^2$. (Ans: 68.96 MN/m^2 , 8°)

12. Two solid shafts of different materials are rigidly connected together and attached to rigid supports as shown in the figure. The aluminium is 4cm in diameter and $G_{al}=30\text{GPa}$ and steel portion has 2cm in diameter and $G_{st}=90\text{GPa}$. If the torque of 20KN-cm is applied at the junction of the two materials, determine the shearing stresses. (Ans: 3472.47N/cm^2 , 1157.49N/cm^2)

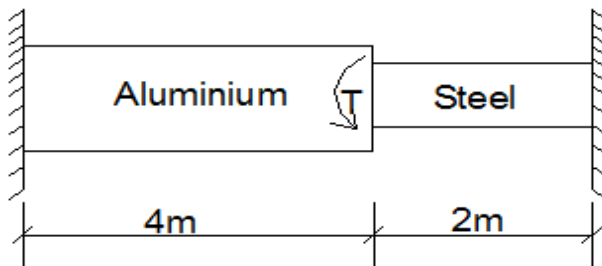

13. A stepped shaft shown in the figure is fixed to a wall at E. Determine the rotation of the end A, when two torques at B and D are applied. Take $G=80 \times 10^9 \text{N/m}^2$.

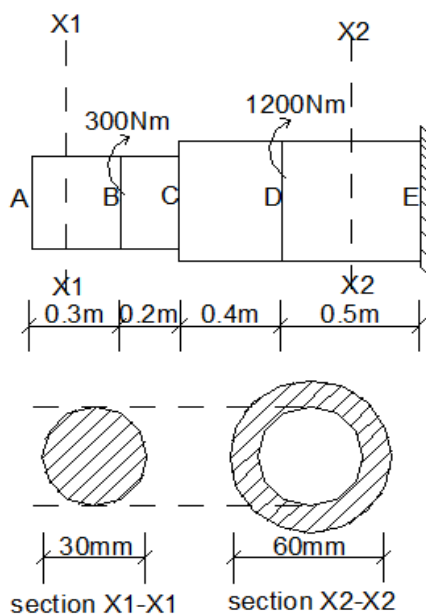

14. A stepped solid circular shaft of dimensions shown in the figure is subjected to three torques. If the material has shear modulus of elasticity $G=80\text{GPa}$, find the angle of twist in degrees at the free end. Also calculate the maximum shearing stress in the shaft.

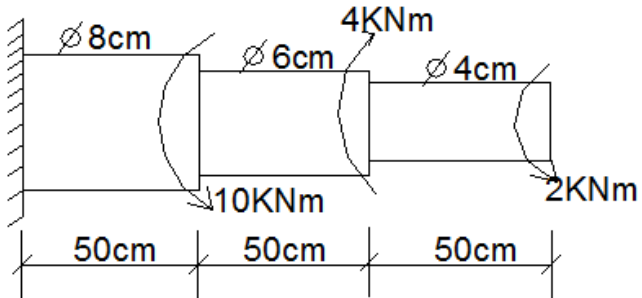

7.Flexure:

1. A beam of I- section is loaded as shown in the figure. If the beam is simply supported over a span of 6m, find the maximum bending stresses. (Ans: 2.52 KN/cm²,3.2KN/cm²)

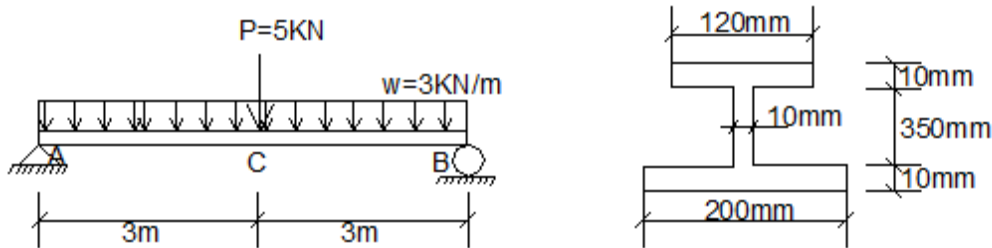

2. A reinforced concrete pipe having 70cm outside diameter and 5cm wall thickness is full of water. At the end, pipe is simply supported having 6m span. Calculate maximum bending stress. Take unit weight of RCC as 25KN/m³.(0.156KN/cm²)

3. A simply supported beam of length 5m is carrying a UDL of w KN/m. The cross section of the beam is as shown in the figure. If permissible bending stress are 160kg/cm² in tension and 200kg/cm² in compression. Find the moment of resistance of the section, actual maximum stresses and external UDL(w) carrying capacity of the beam if 900kg point load is applied at the center. (Ans: 340253kg-cm, 200kg/cm², 148.23kg/cm², 728.8kg/m)

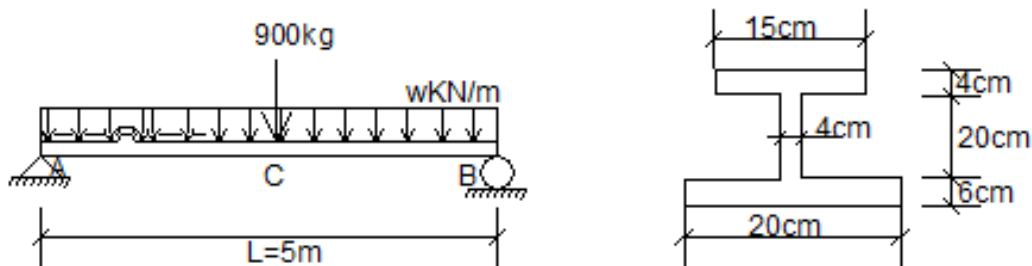

4. A timber beam 6cm wide and 10cm deep is to be strengthened by bolting on two steel plates, each being 6cm by 0.5cm in section. Compare the moments of resistance for the same value of maximum bending stress if;

(a) Plates are attached symmetrically at the top and bottom

(b) Plates are attached symmetrically at the sides

Take $E_s=2.1 \times 10^5 \text{N/mm}^2$ and $E_t=1.4 \times 10^4 \text{N/mm}^2$. (Ans: 3.87)

5. Determine the maximum deflection for the beams loaded as shown in the figure by double integration method.

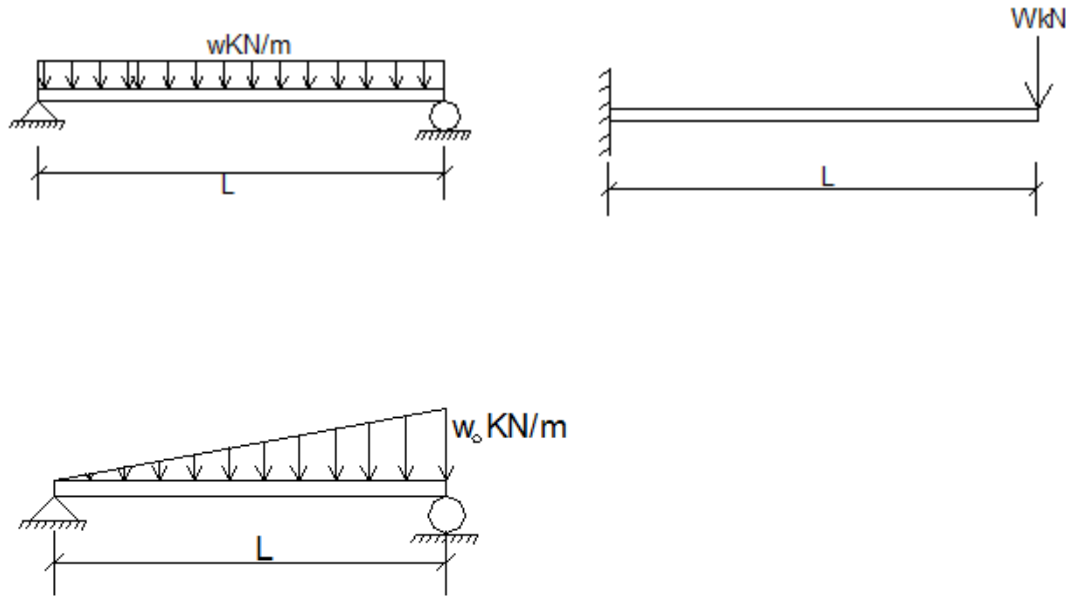

6. For the beam loaded as shown in the figure, determine the maximum shearing stress in the beam. Also determine the shearing stress at a point 3cm below the top fiber of the beam at a section 1m from support A. (Ans: $1\text{KN}/\text{cm}^2$, $0.5\text{KN}/\text{cm}^2$)

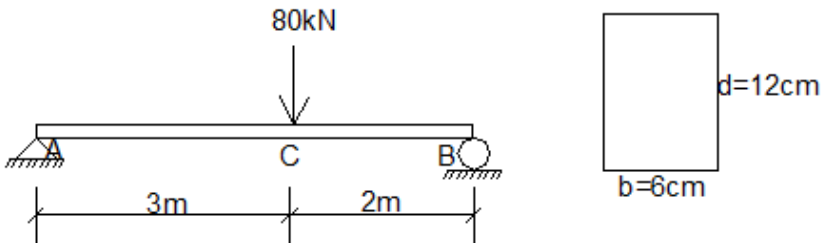

7. An I section beam flange $20\text{cm} \times 2\text{cm}$ and web $30\text{cm} \times 1\text{cm}$ is acted on by shearing force of 150KN . Determine;

- The maximum and minimum shear stress in the flange.
- The maximum and minimum shear stress in the web.
- The shearing stress at a layer of 6cm below the top of the section.

8. A beam simply supported at the ends has an I cross section with dimensions of upper flange 10cmX3cm, bottom flange 15cmX5cm and web 3cmX15cm. The beam is 6m long and permissible bending stresses are limited to 50MN/m^2 in tension and 30MN/m^2 in compression. Determine the intensity of UDL that can be placed over the whole span. Also, determine actual maximum bending stresses developed.

9. A cantilever beam 3m in length is subjected to load as shown below. Determine maximum bending stress at 25mm below from the top surface of the beam.

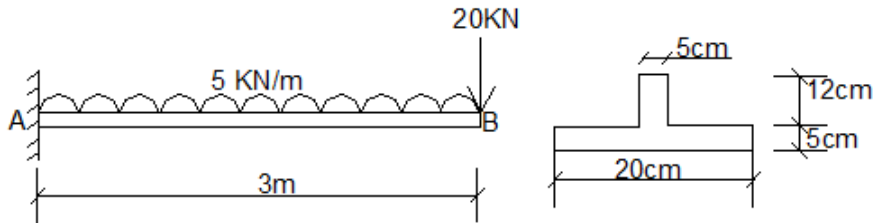

10. A simply supported beam of 6m span is subjected to concentrated loads of 20kN as shown in the figure. Calculate (i) The position and the value of maximum deflection (b) Deflection under the point load. (Use Macaulay's method)

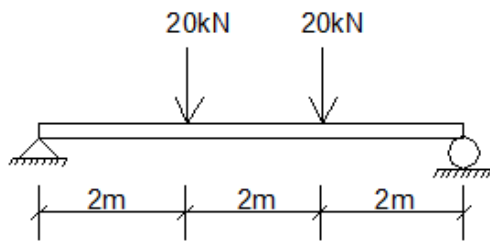

11. Determine the maximum value of P in the simply supported beam shown in figure below if the bending stress is limited to 12000KN/m^2 .

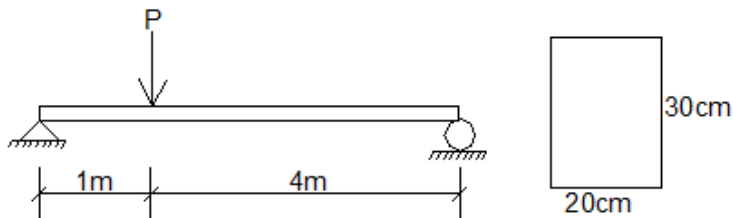

12. A simply supported timber joist of 5m span has to carry UDL 6KN/m over its whole span and a point load of 15KN at its center. Determine the dimensions of the joist if the maximum permissible stress in bending is 10N/mm^2 . Take the depth of the joist is twice of its breadth.

8.Column:

1. A hollow mild steel tube is 6m long and 5cm internal diameter. Thickness of tube is 8mm and it is used as a strut with both ends hinged. Determine the critical load and safe load on the strut. Take $E=2.1 \times 10^5 \text{ N/mm}^2$ and factor of safety as 3. (Ans: 11.987KN)

2. A column of timber is 6m long and hinged at one end and fixed at the other. Determine the crippling load and the safe load for the column. Take factor of safety=2.5 and cross section of the column as shown below. $E=10 \text{ KN/mm}^2$. (Ans: 1937.95KN)

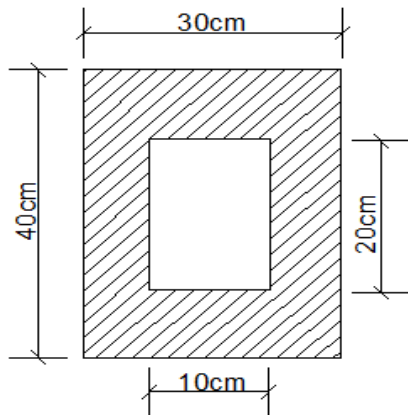

3. A built up beam is simply supported at the ends. Determine its length when it is subjected to a load of 4KN/m. Due to this load it deflects by 1cm. Also find out the safe load if the same beam is used as a column with both ends fixed. Take $E=2100 \text{ tonnes/cm}^2$ and factor of safety as 3. (Ans: 271.09tonnes)

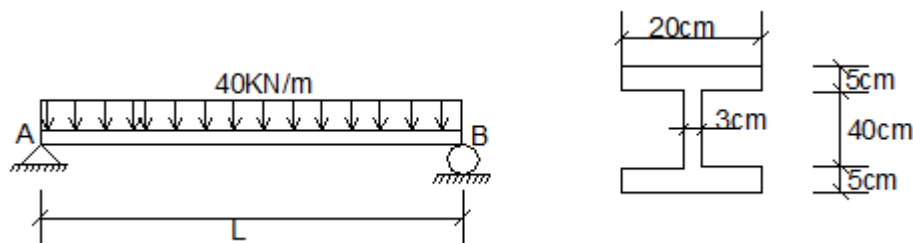

4. A cast iron hollow cylindrical column 4m long is hinged at both ends and its critical buckling load is P kg. When the same column is fixed at both the ends, its critical load rise to $(P+50,000)$ kg. If the ratio of external diameter to the internal diameter is 1.30 and $E=10^6 \text{ kg/cm}^2$, determine the external diameter of the column. (Ans: 9.6cm)

5. Compare the ratio of the strength of a solid steel column to that of a hollow of the same cross-sectional area. The internal diameter of the hollow column is $\frac{3}{4}$ of the external diameter. Both the columns have the same length and are pinned at both ends. (Ans: 25/7)

6. An I-section joist with flanges 200mmX20mm and web 360mmX20mm and 6m long is used as a strut with both ends fixed. What is Euler's crippling load for the column? Take Young's modulus for the joist as 200GPa. (Ans: 638.2KN)

7. A T-section 150mmX120mmX20mm is used as a strut of 4m long with hinge at its both ends. Calculate the crippling load, if Young's modulus for the material be 200GPa. (Ans:702KN)

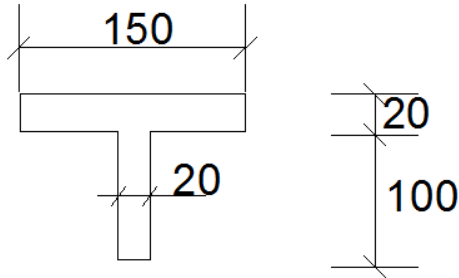

8. A strut in a frame structure is formed of a mild steel pipe of 15cm external diameter and 1cm thick. If it is 3m long and have pinned jointed ends and FOS=5. Find the load to which the strut may be subjected. Take yield stress as 33.1KN/cm². (Ans: 195.8KN)

9. A solid circular compression member 50mm in diameter is to be replaced by a hollow circular section of the same material. Find the size of the hollow section, if internal diameter is 0.8 times the external diameter. [Hint: $P_{cr(solid)}=P_{cr(hollow)}$]

ALL THE BEST