

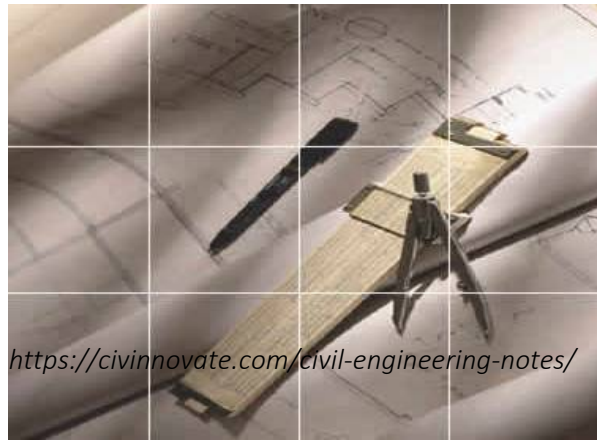

Chapter 4

Orthographic Writing



<https://civinnovate.com/civil-engineering-notes/>



TOPICS

- Views selection
- Alignment of views
- Orthographic writing steps
- Basic dimensioning
- Tangency and intersections



View Selection



<https://civinnovate.com/civil-engineering-notes/>

VIEW SELECTION STEPS

1. Orient the object to the best position **relative** to a glass box.
2. Select the front view.
3. Select adjacent views.

STEP 1 : Orient the Object

- The object should be placed in its **natural position**.
- The object should presents its features in **actual size** and **shape** in orthographic views.

GOOD

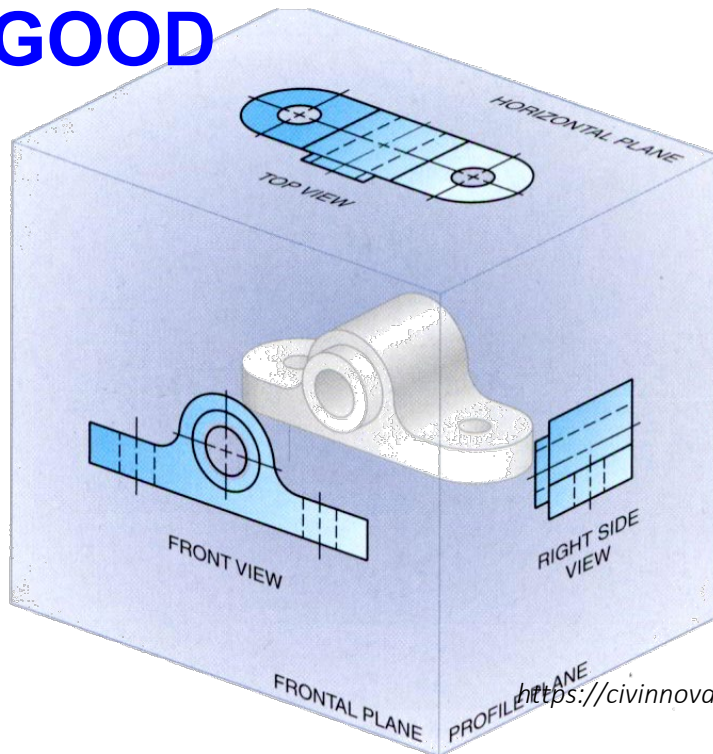

NO !

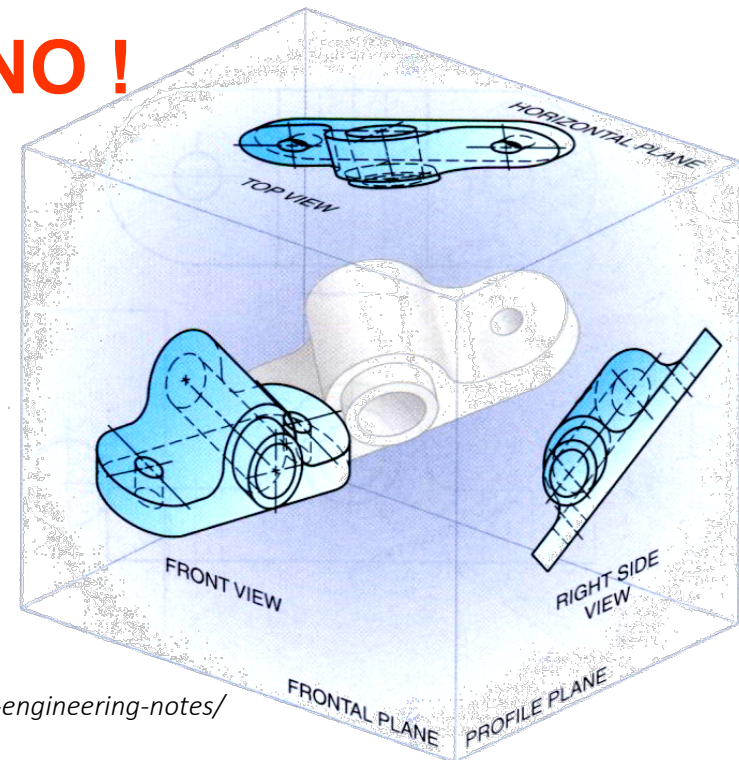

STEP 2 : Select a Front View

- The object's **longest dimension** should be presented as a **width**.

First choice



Waste more space

Inappropriate

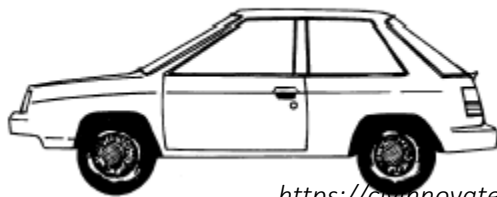

Second choice

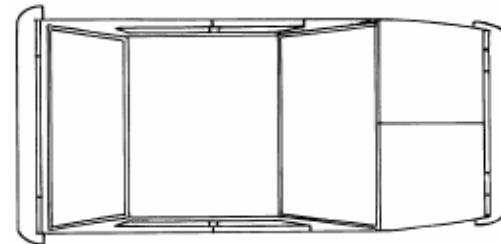

GOOD

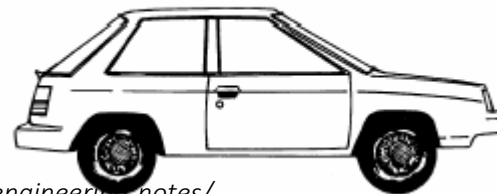

STEP 2 : Select a Front View

- The adjacent views that are projected from the selected front view should appear in its natural position.

Inappropriate

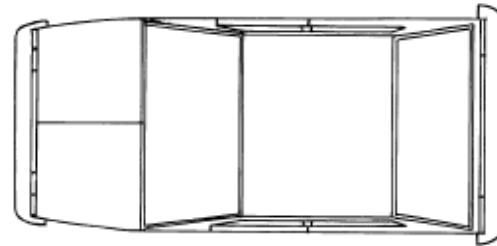
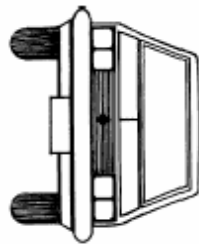
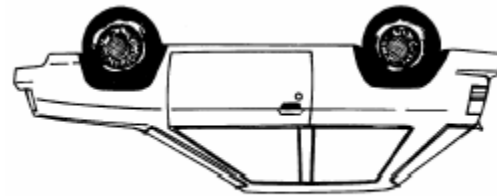

STEP 2 : Select a Front View

- Choose the view that have the **fewest number of hidden lines**.

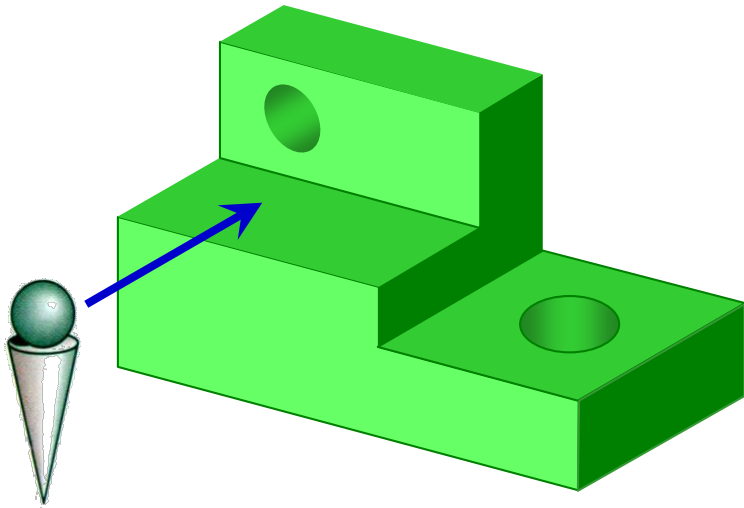

GOOD

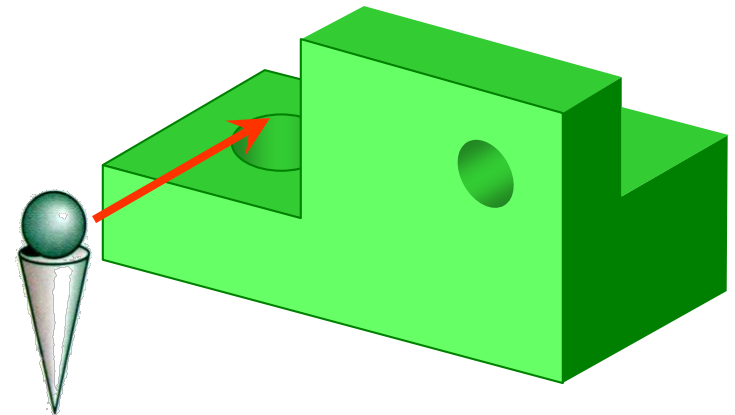
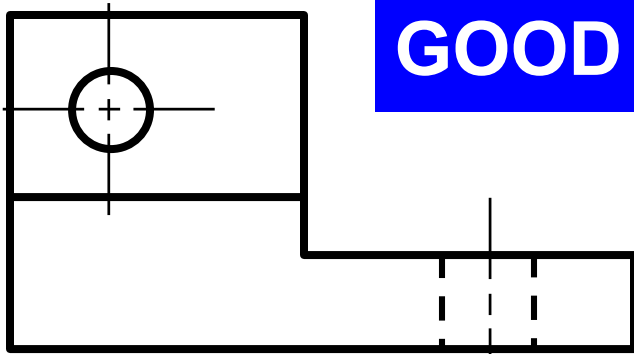

Inappropriate

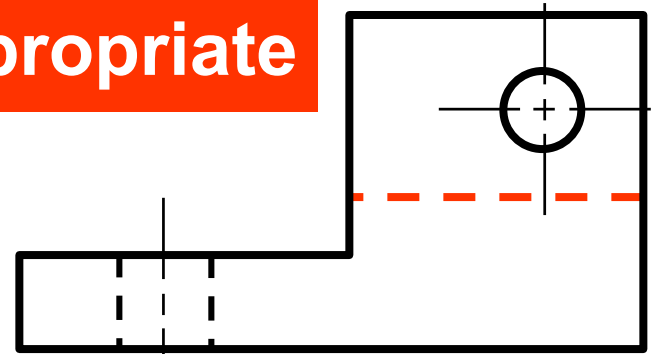

STEP 3 : Select an Adjacent View

- Choose the view that have the fewest number of hidden lines.

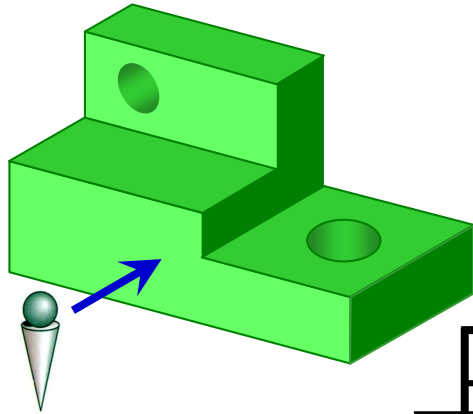

GOOD

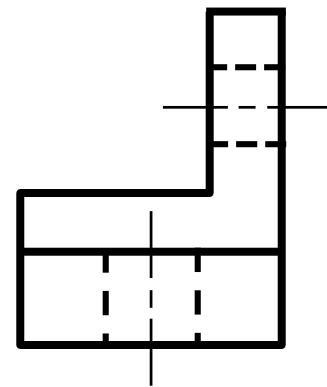
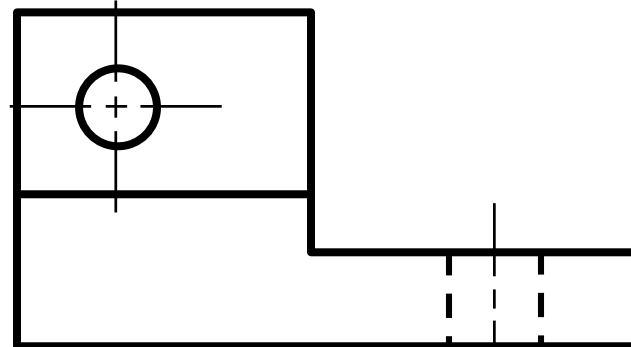
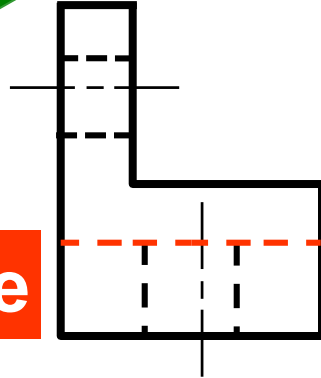
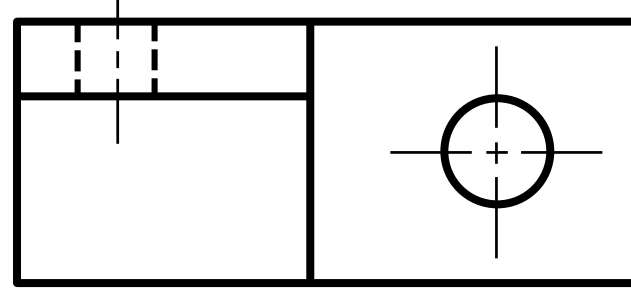

GOOD

Inappropriate

Inappropriate

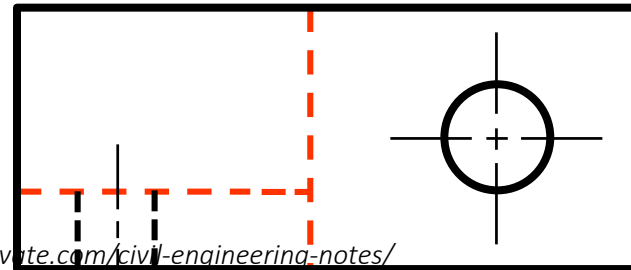

STEP 3 : Select an Adjacent View

- Choose the **minimum** number of views that can represent the major features of the object.

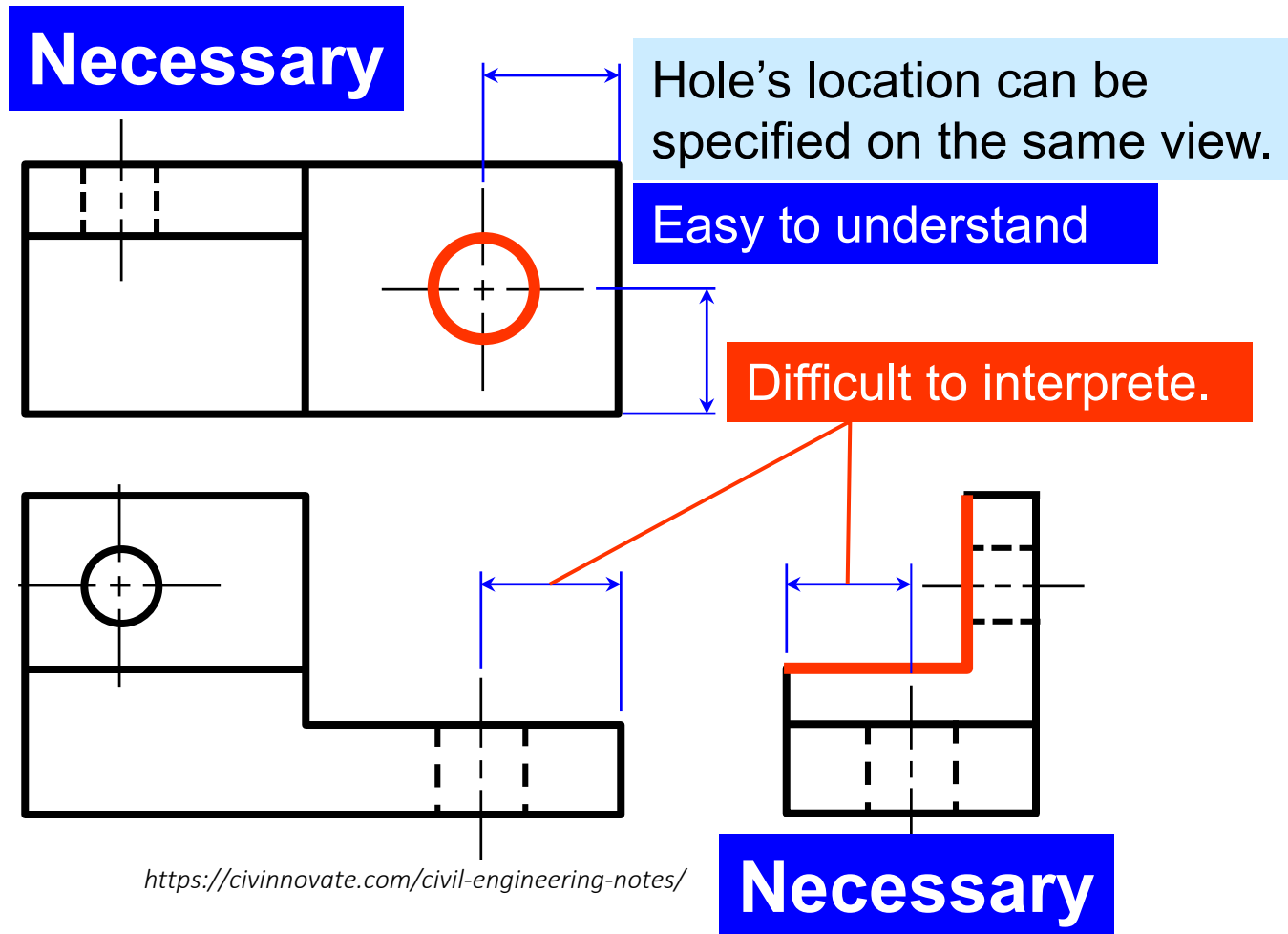
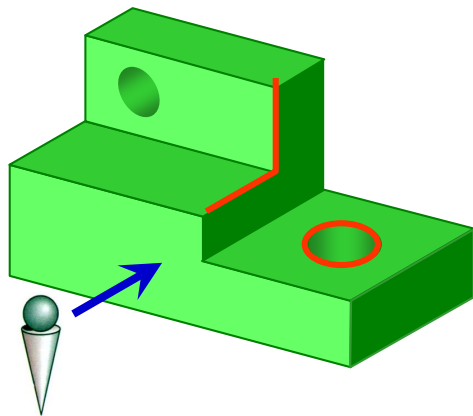

STEP 3 : Select an Adjacent View

- Choose the views that are suitable to a drawing space.

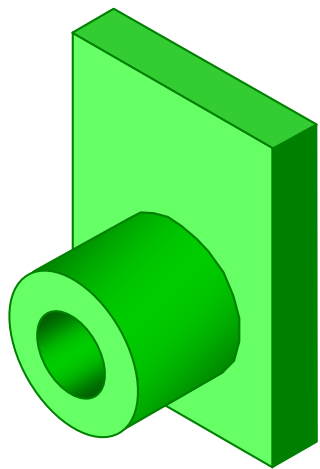

Not enough space for dimensioning.

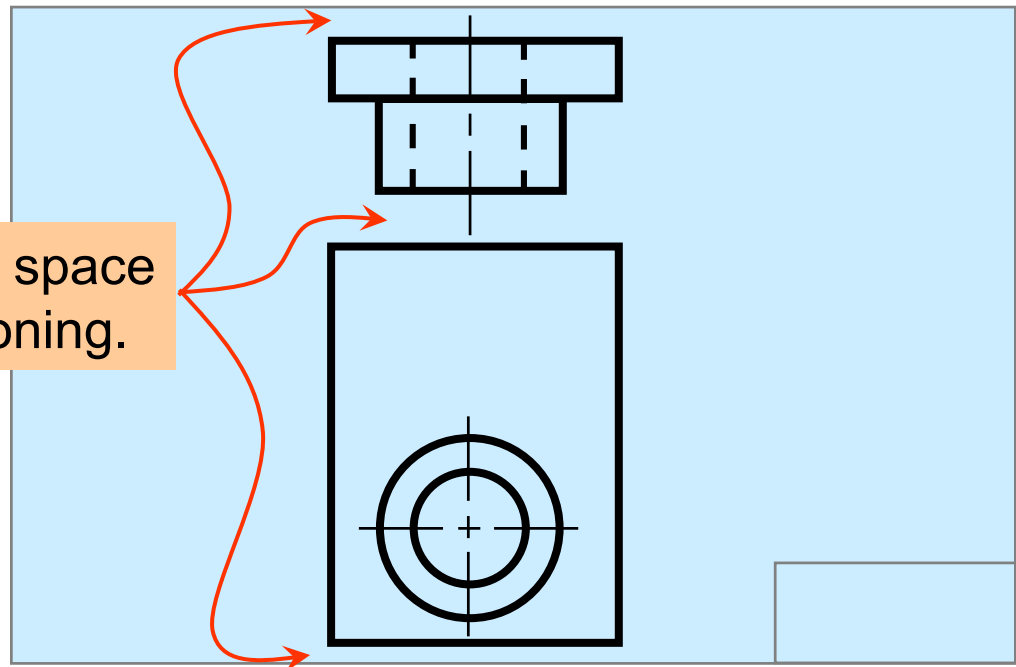

STEP 3 : Select an Adjacent View

- Choose the views that are suitable to a drawing space.

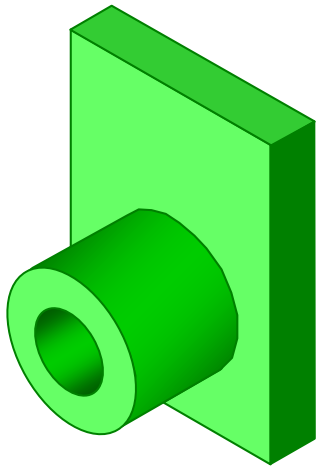

GOOD

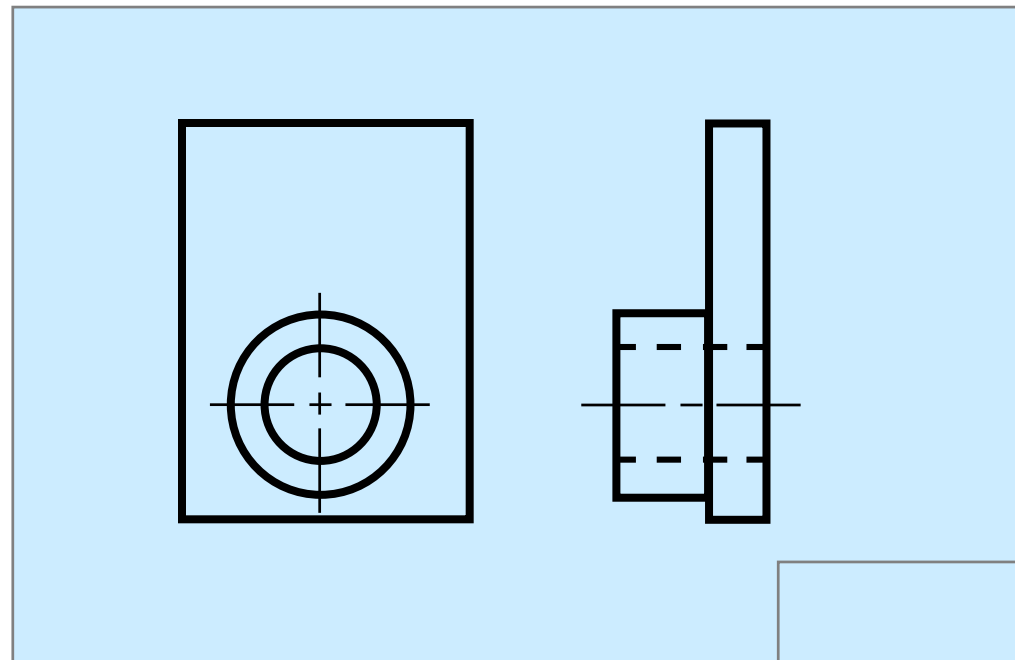

Example : View selection

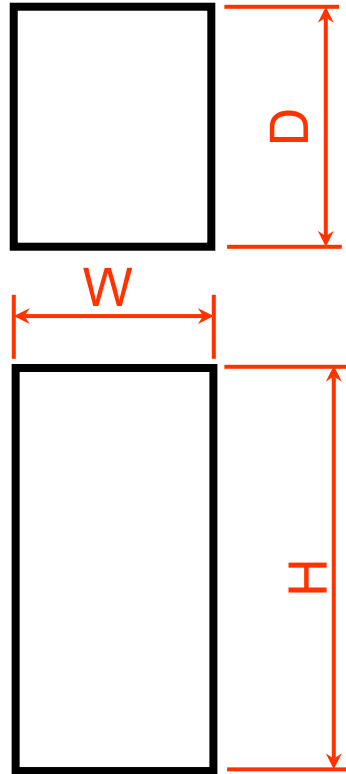
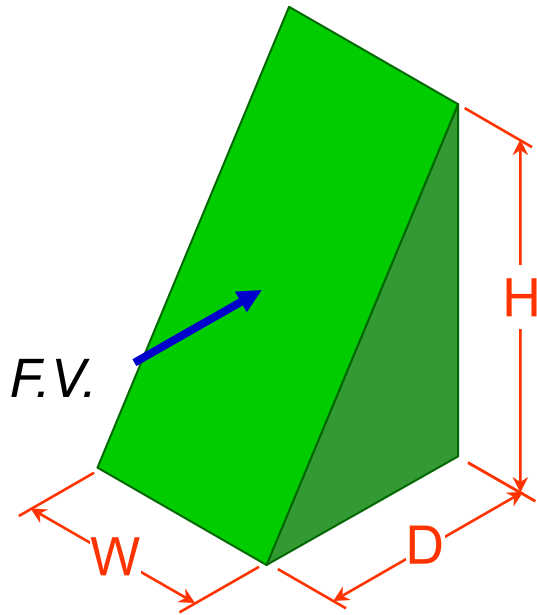

mislead to...

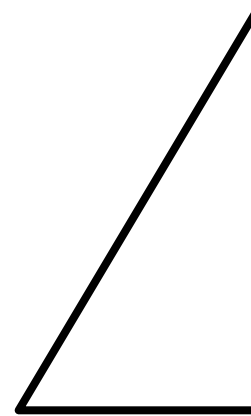
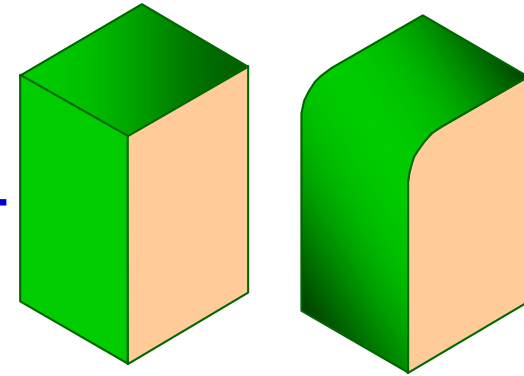

F.V. & T.V.

Three views

F.V. & R.S.V.

Size description



Shape description



ONE-VIEW DRAWING

- **Flat part** having a uniform thickness.

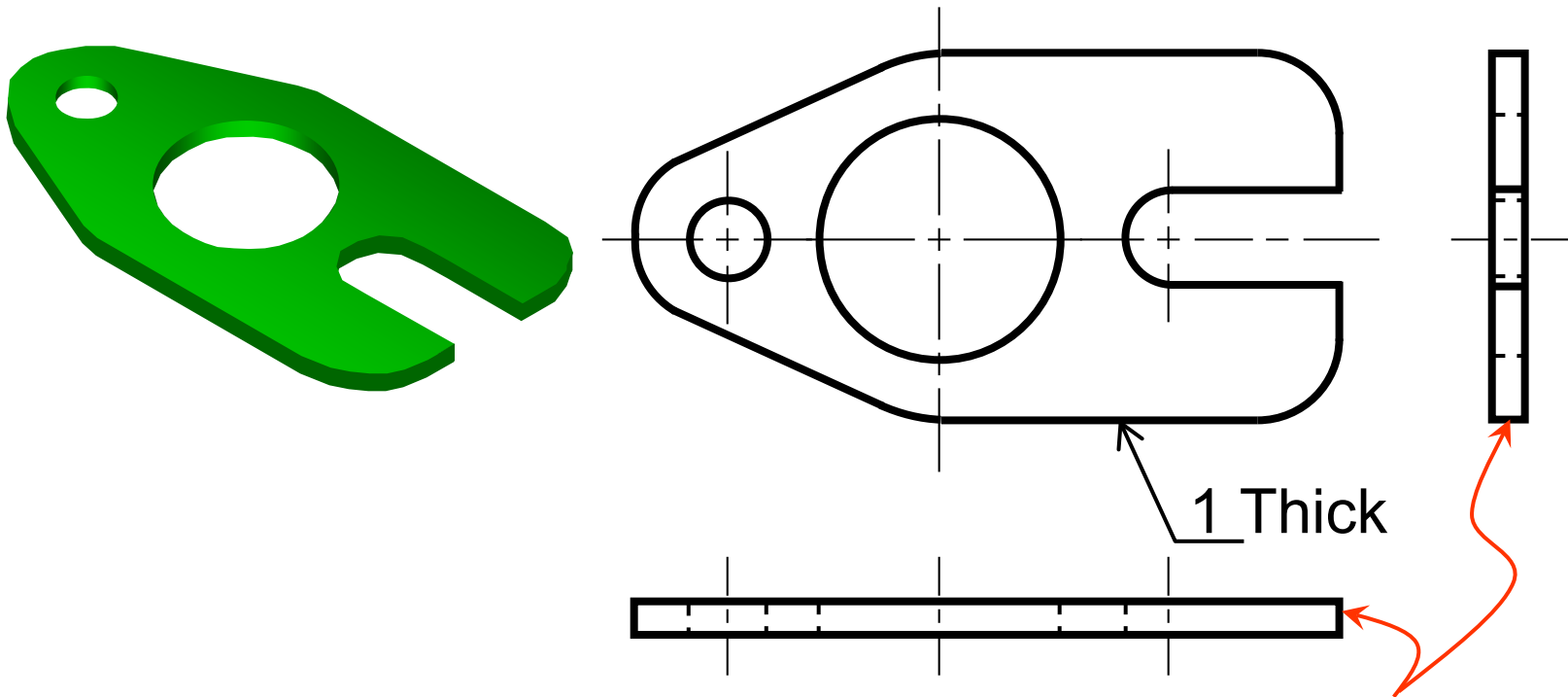

Unnecessary

These 2 views provide only information about the part thickness !

ONE-VIEW DRAWING

- ***Cylindrical-shaped*** part.

Unnecessary

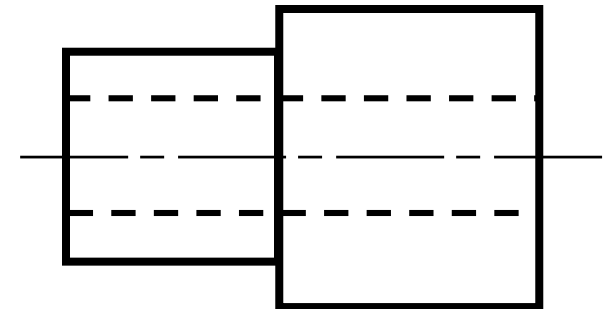
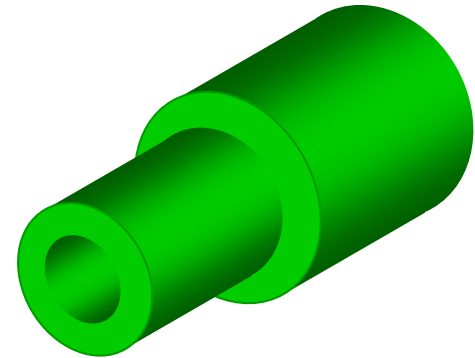
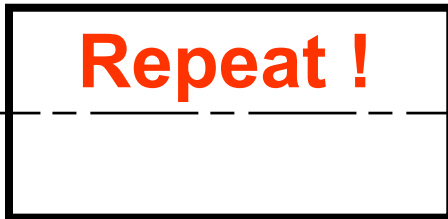
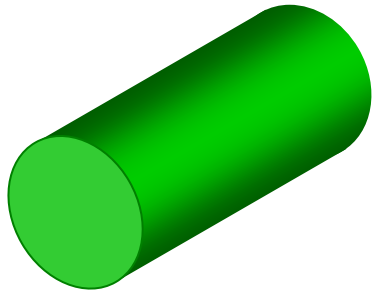

Infer from CL

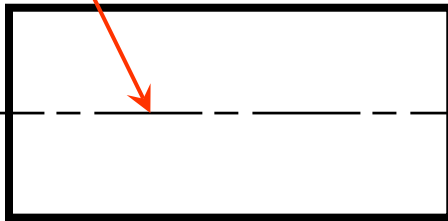
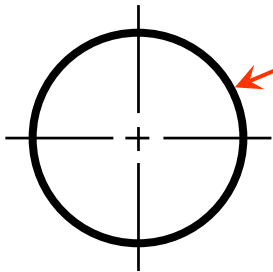

Unnecessary

TWO-VIEW DRAWING

- There exists an identical view.

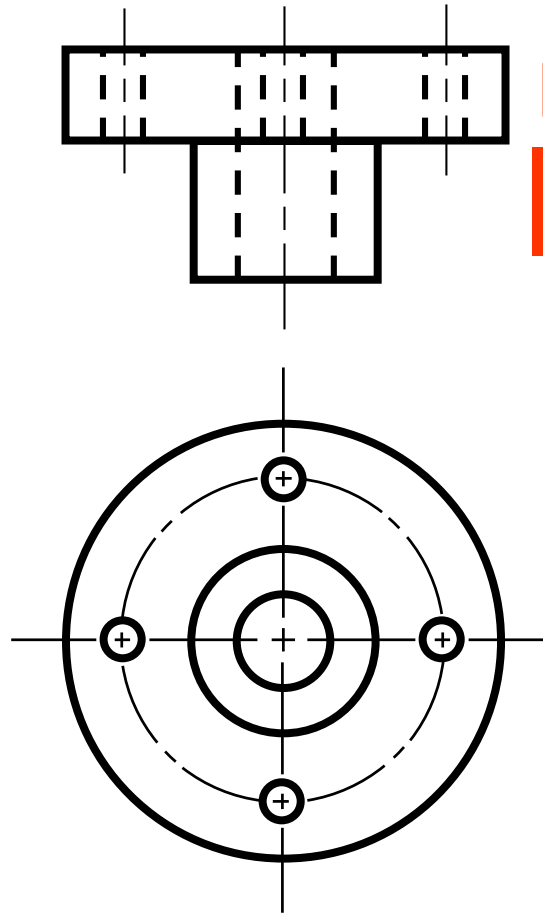
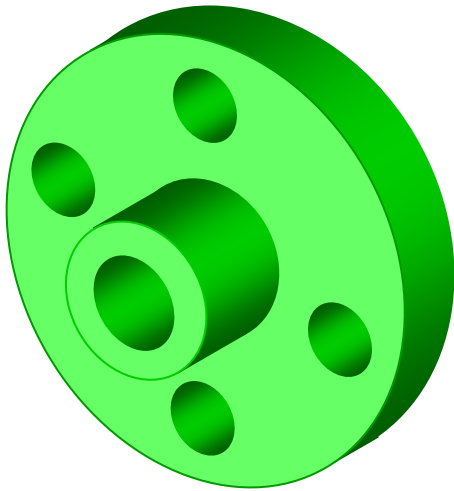

Repeat !

Unnecessary

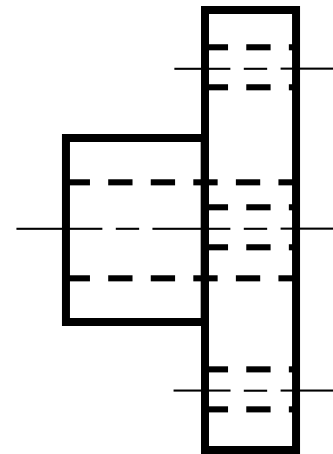

TWO-VIEW DRAWING

- The 3rd view has no significant contours of the object.

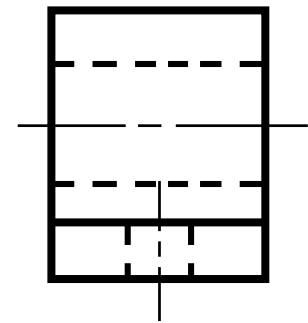
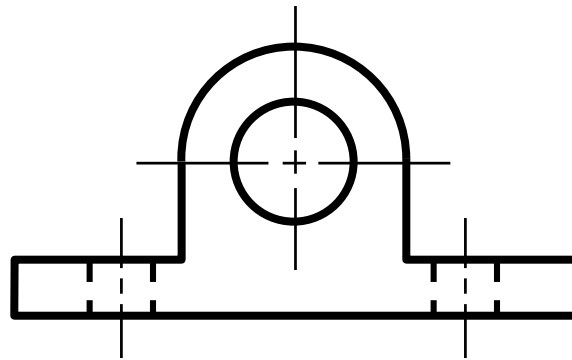
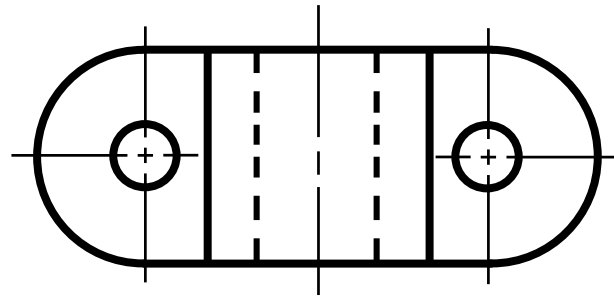
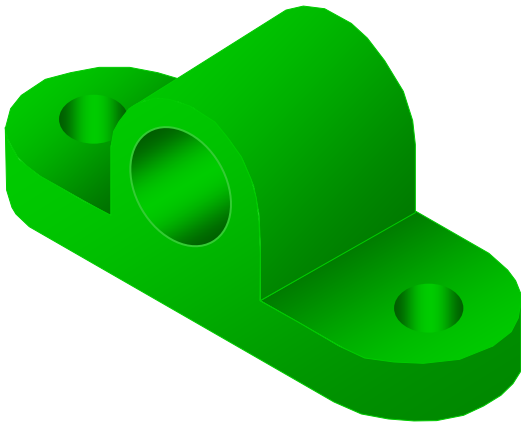

Unnecessary

TWO-VIEW DRAWING

- The 3rd view has no significant contours of the object.

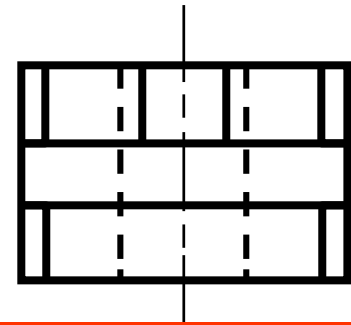
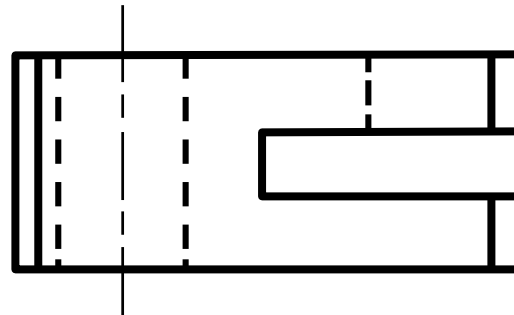
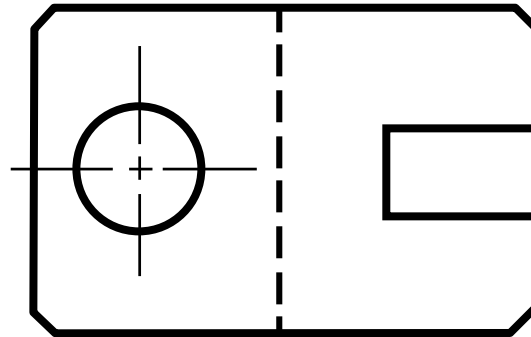
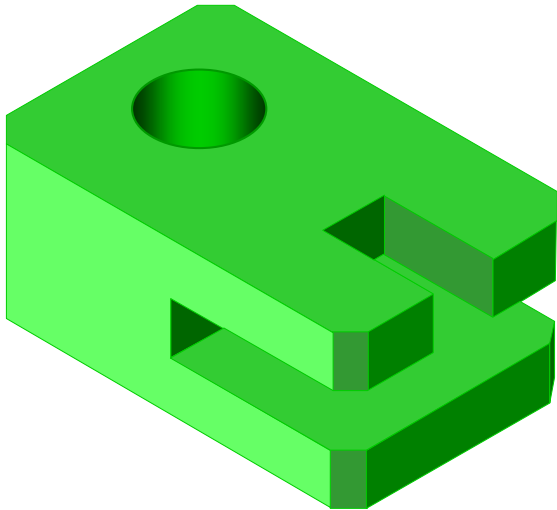

Unnecessary



Alignment of Views



<https://civinnovate.com/civil-engineering-notes/>

PROJECTION SYSTEMS

1. First angle system

- European country
- ISO standard

2. Third angle system

- Canada, USA, Japan, Thailand

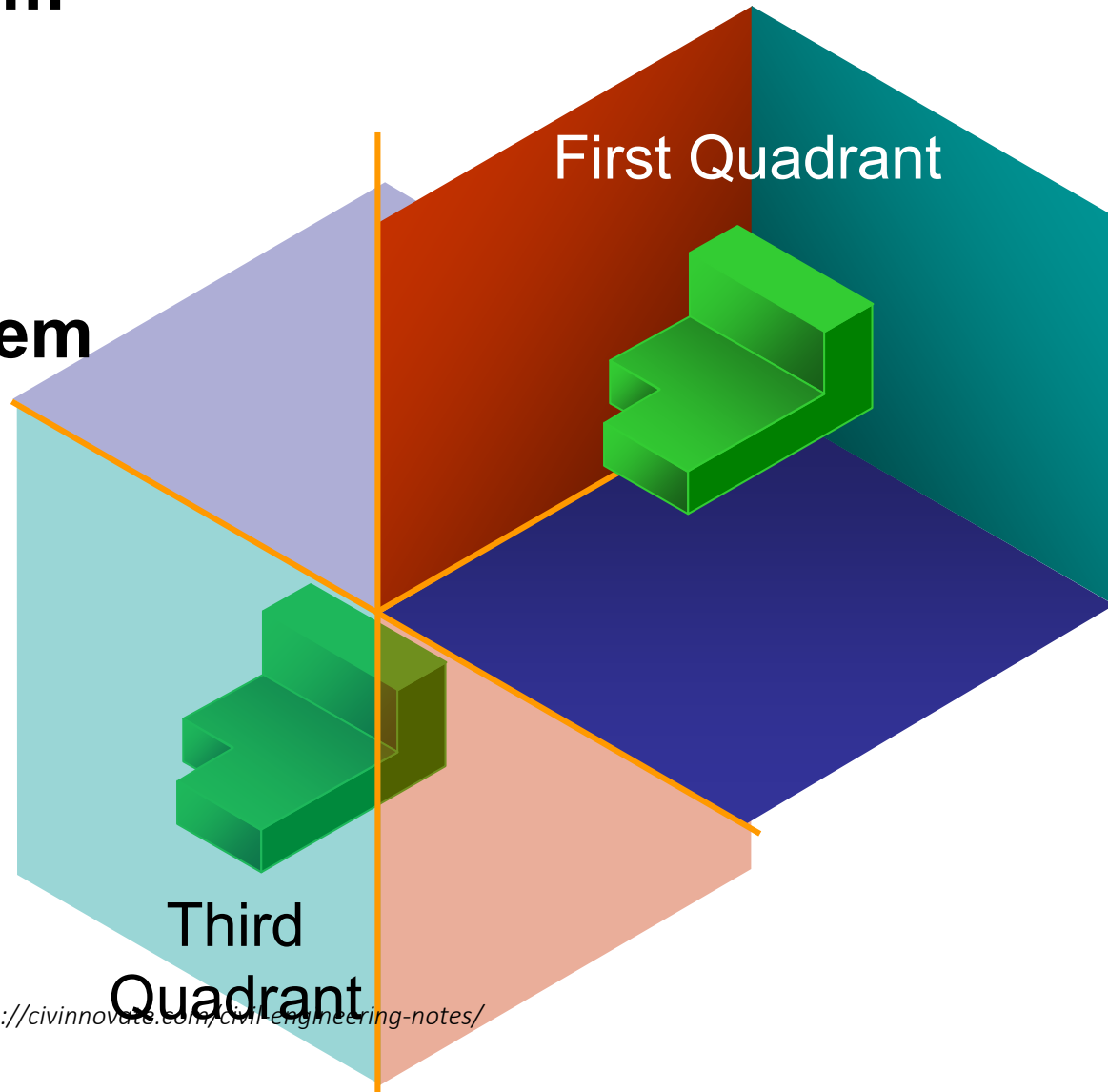

ORTHOGRAPHIC PROJECTION

1st angle system

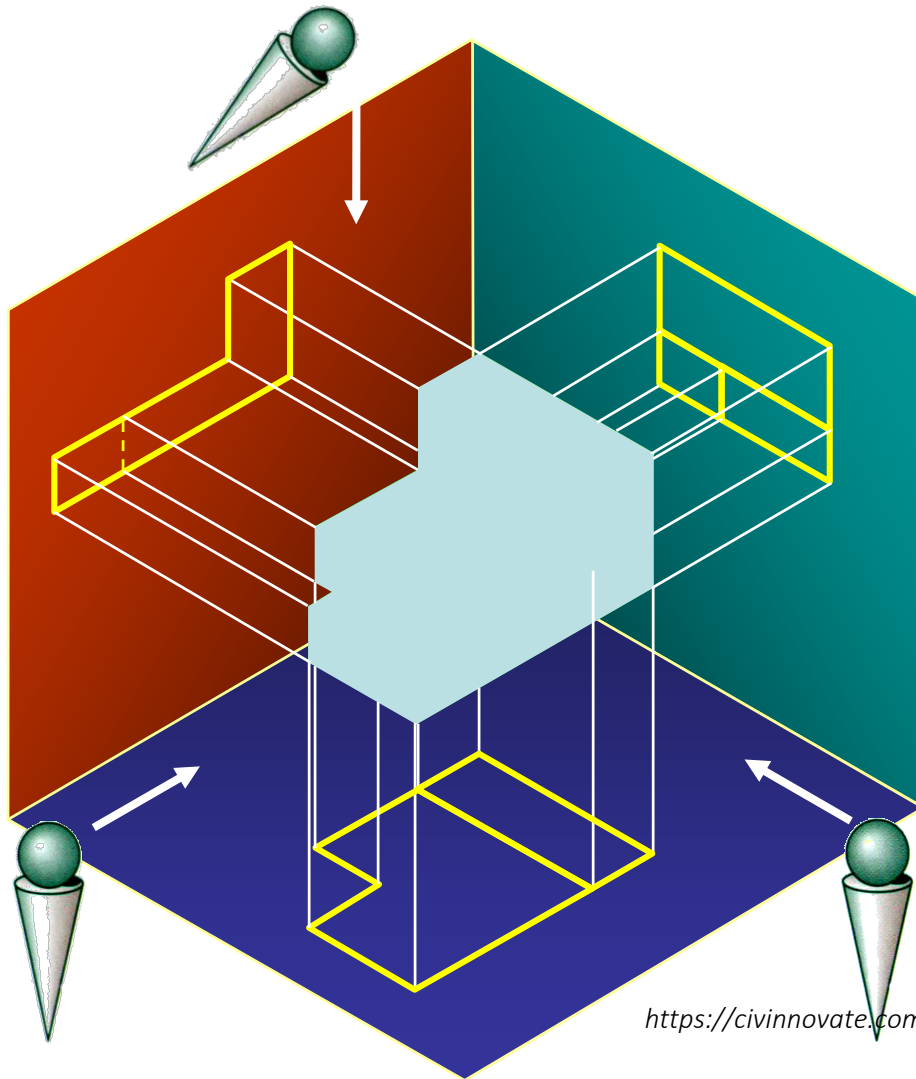

3rd angle system

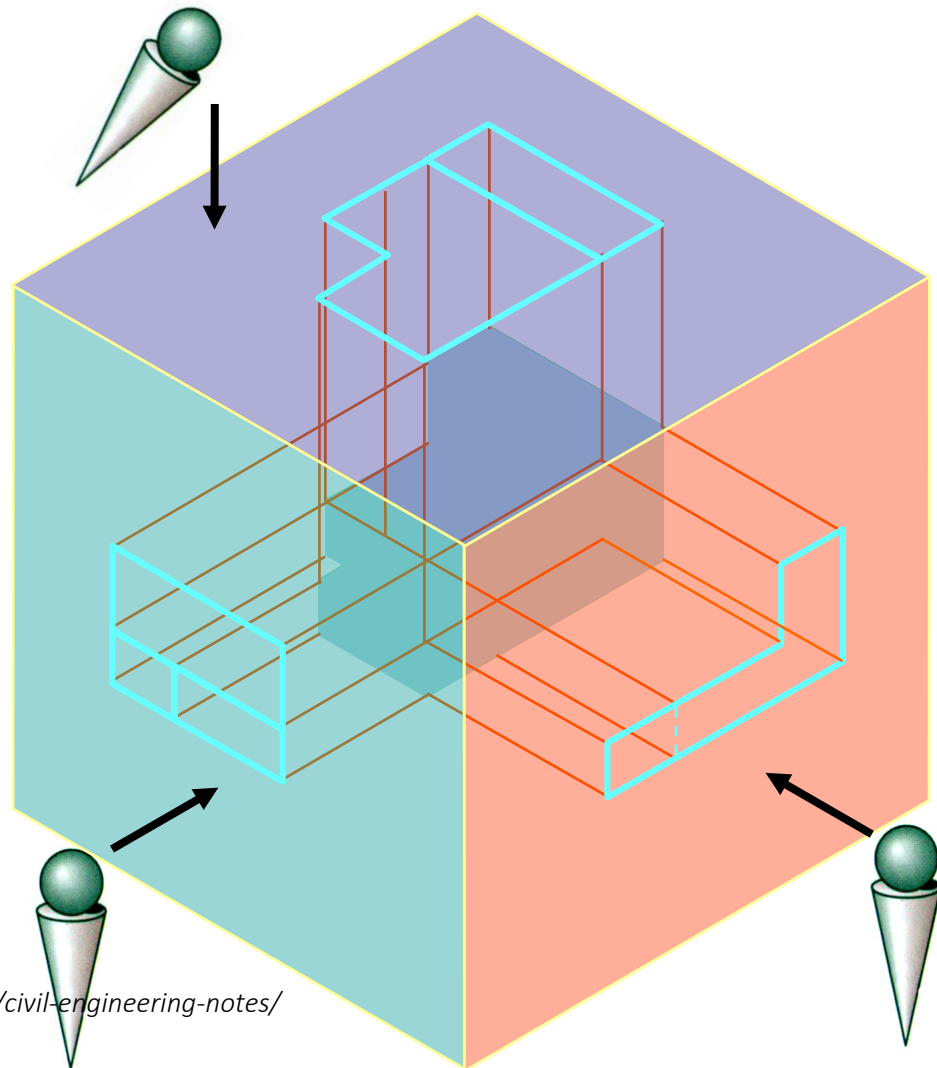

ORTHOGRAPHIC VIEWS

1st angle system

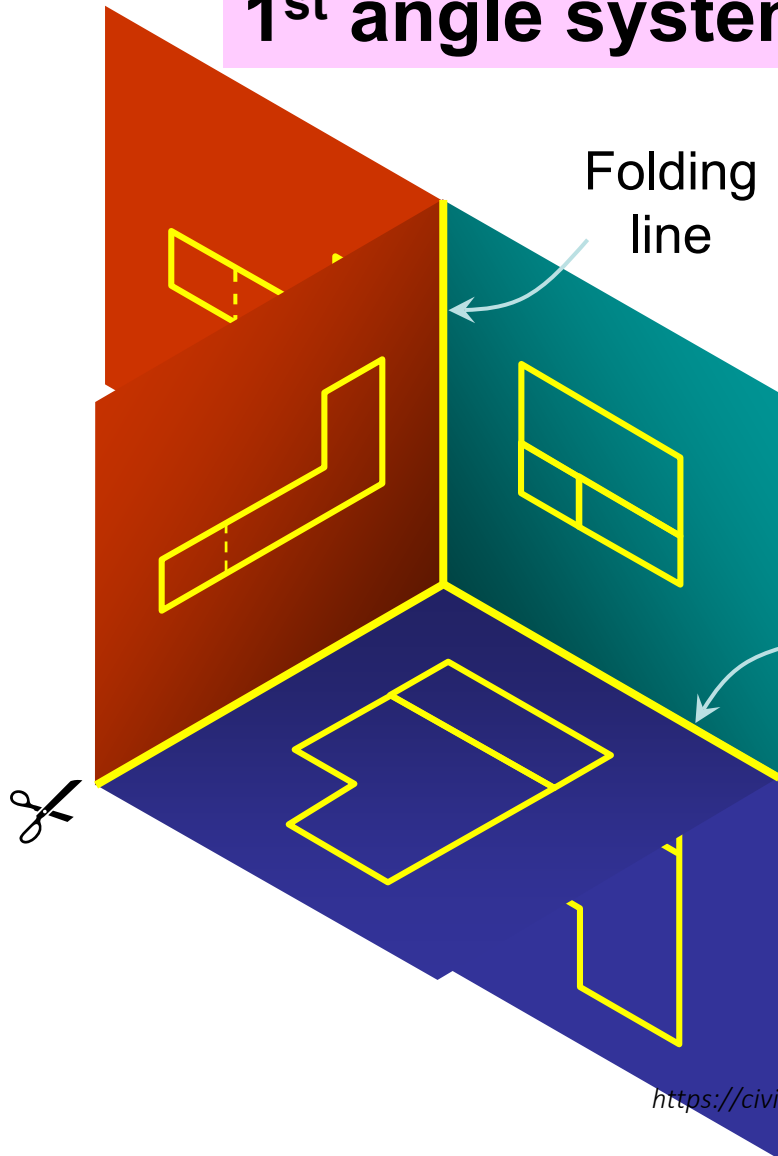

3rd angle system

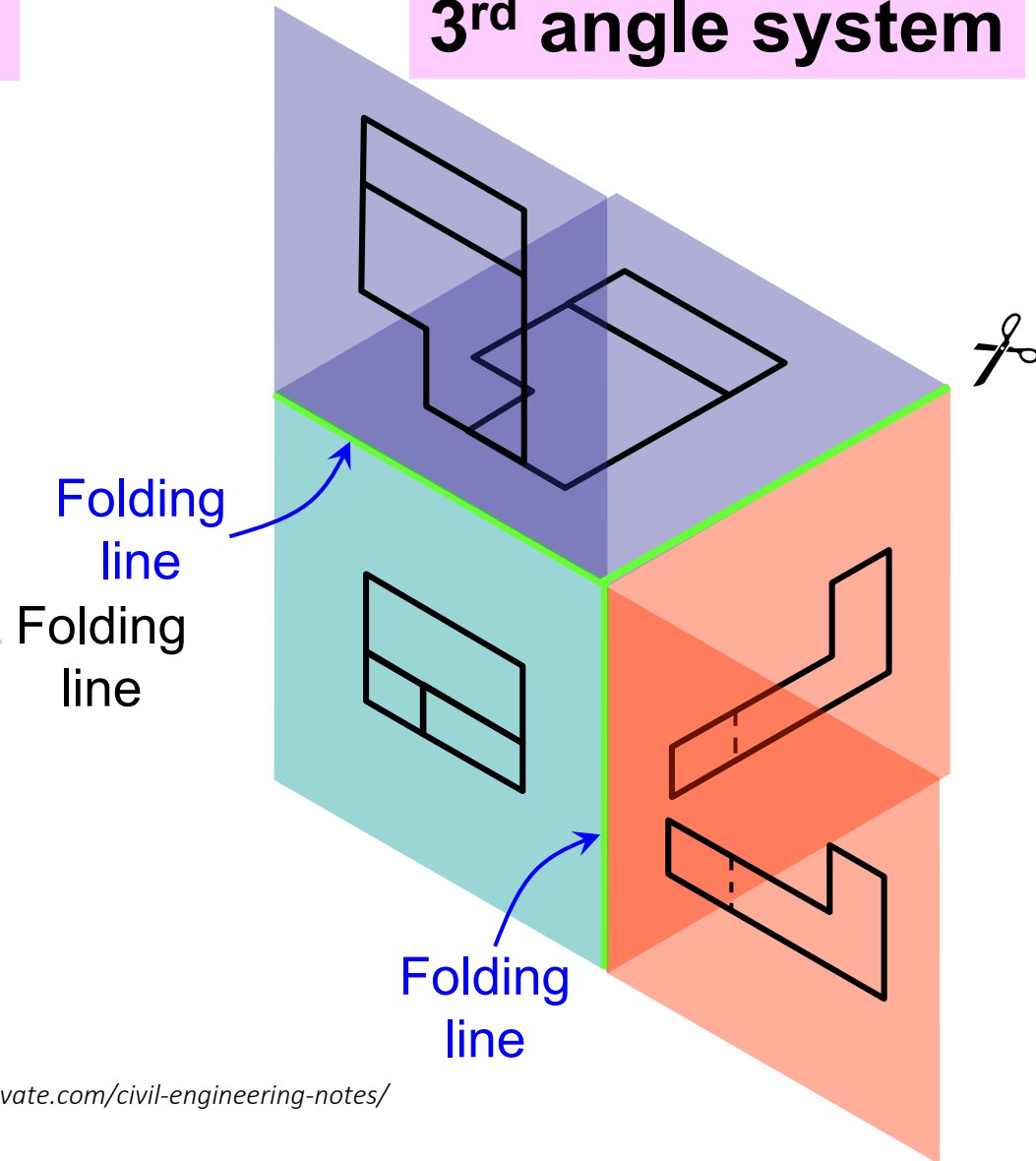

ORTHOGRAPHIC VIEWS

1st angle system

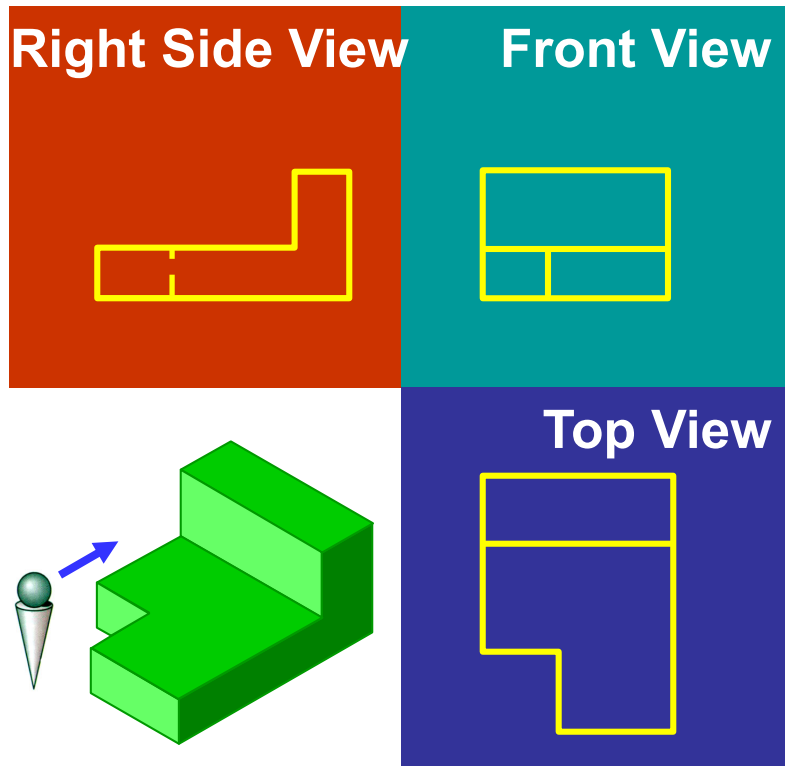

3rd angle system

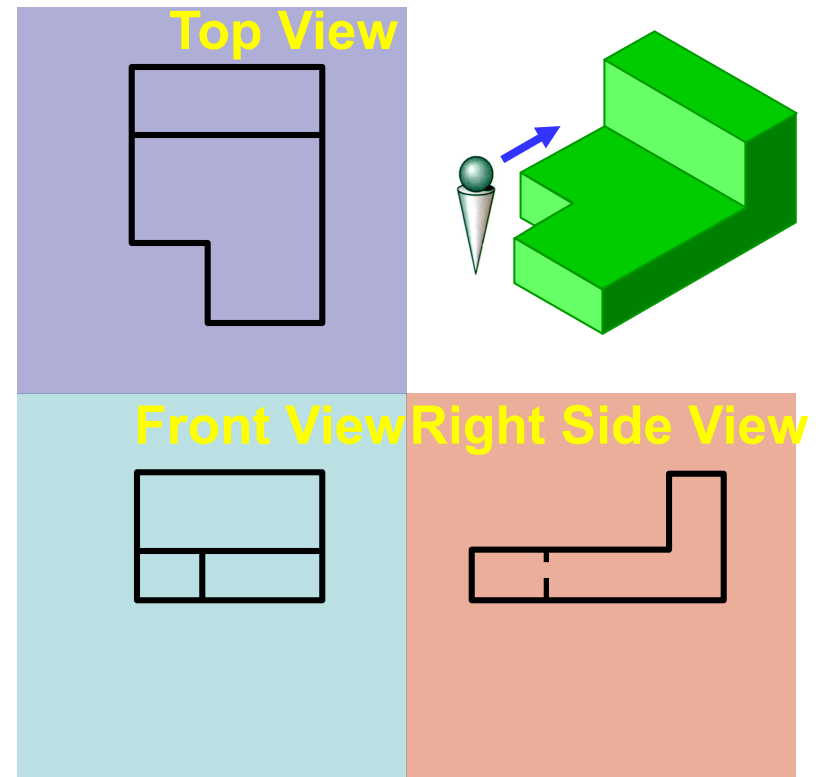

PROJECTION SYMBOLS

First angle system

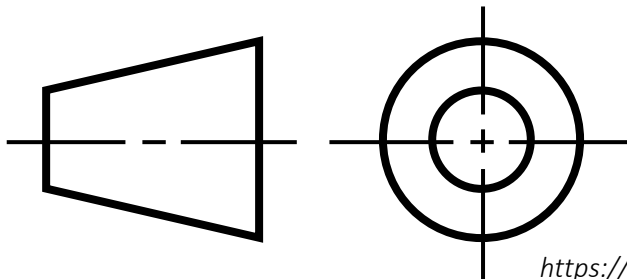
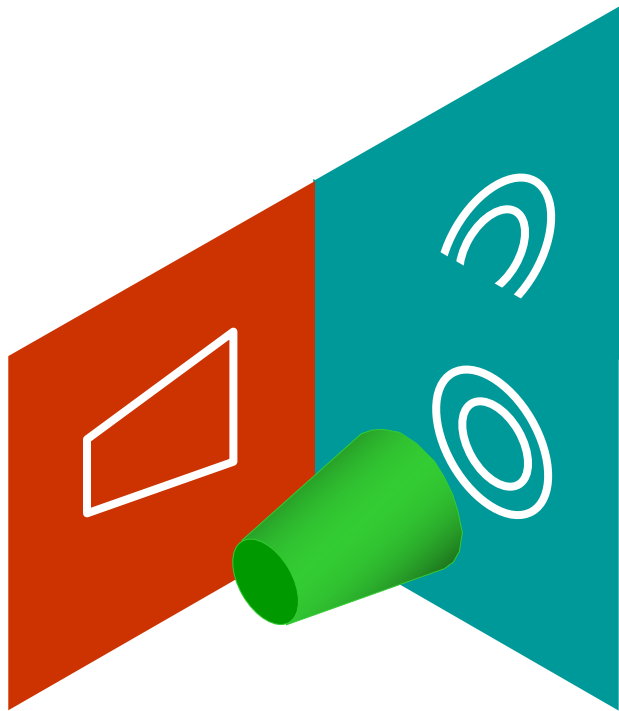

Third angle system

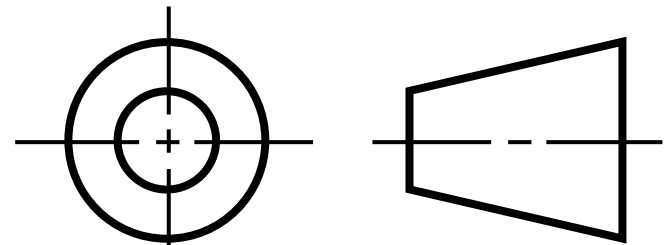
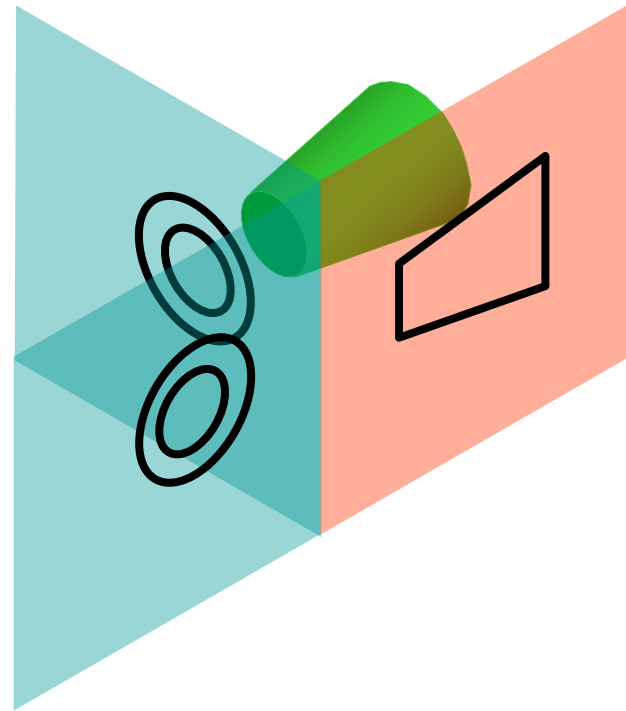

PROJECTION SYMBOLS

Suggested proportion

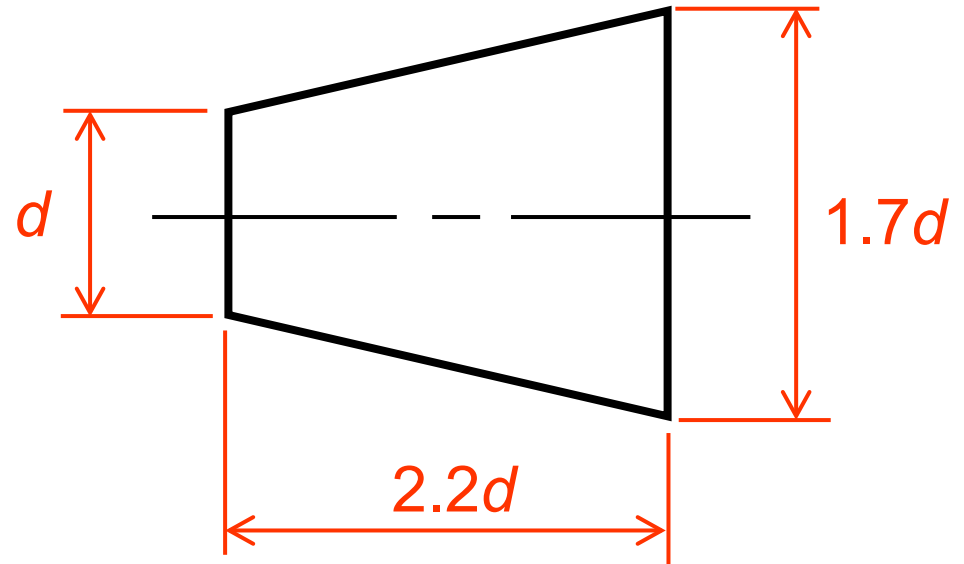
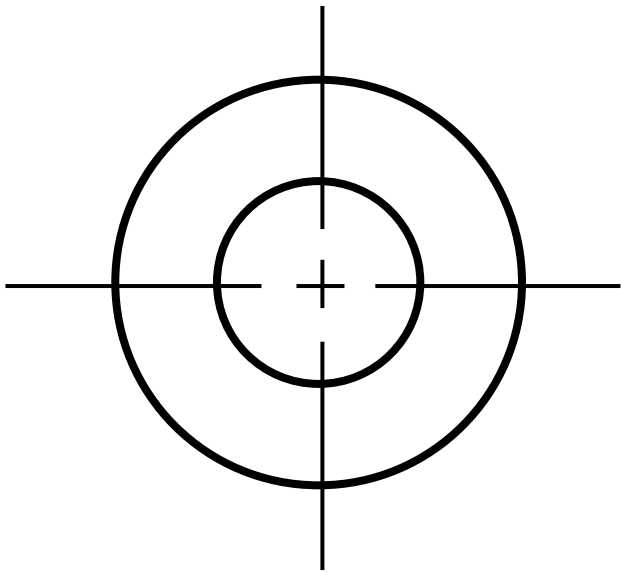



Orthographic Writing Steps



<https://civinnovate.com/civil-engineering-notes/>

WRITING STEPS

1. Select the necessary views
2. Layout the views.
3. Project the views.
4. Dimension the views.

1. SELECT THE NECESSARY VIEWS

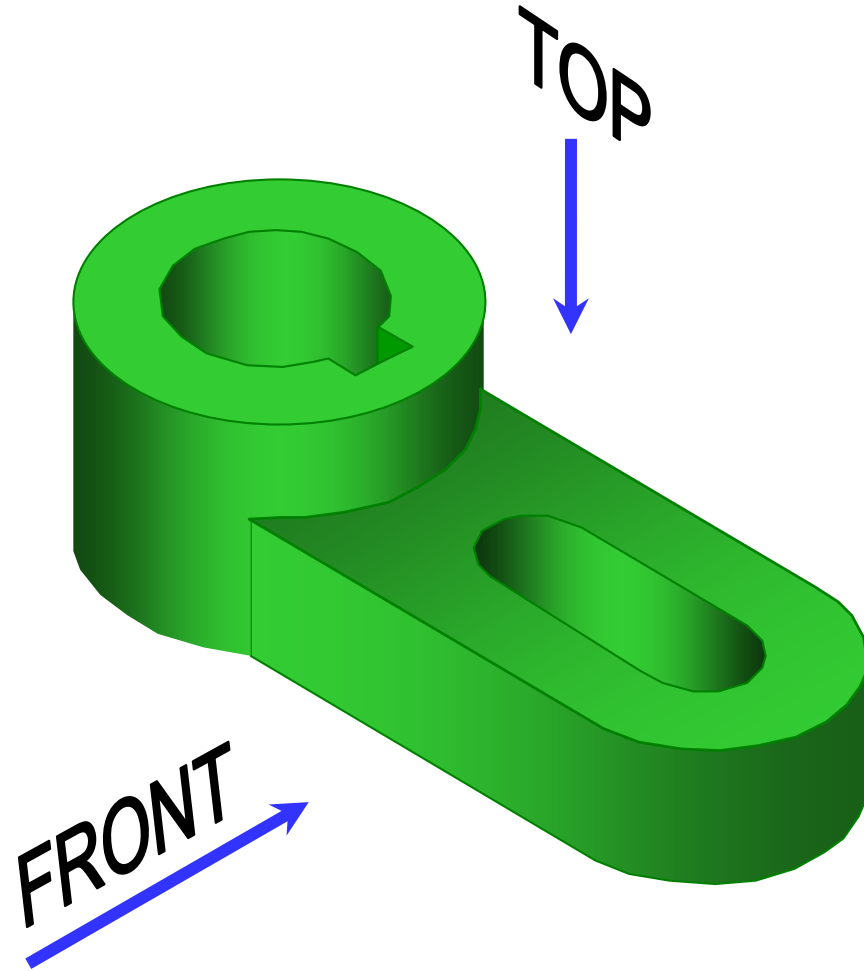

2. LAYOUT THE VIEWS

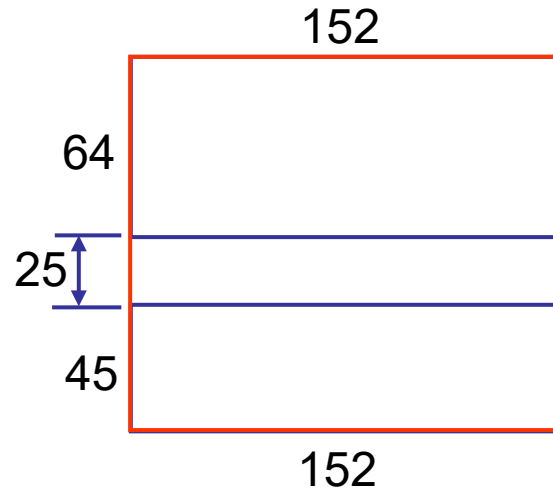
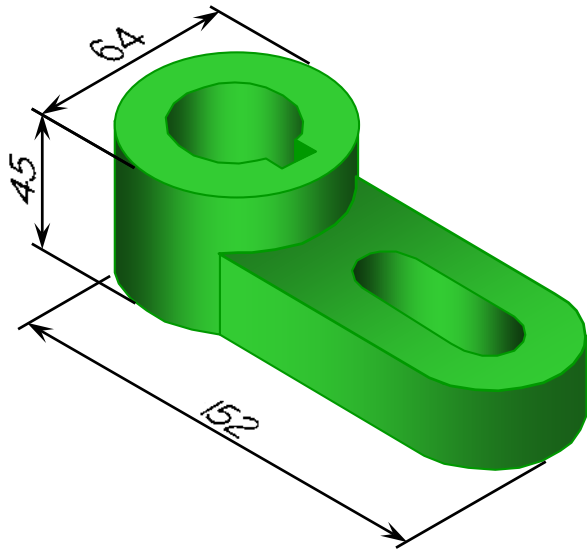

152

Choose an appropriate scale

1:1

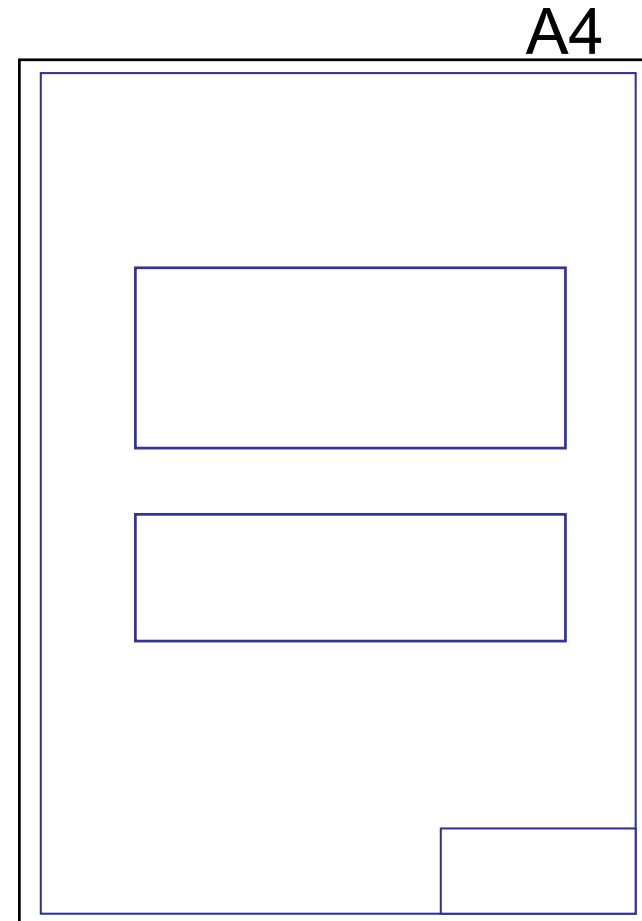

PROJECT THE VIEWS

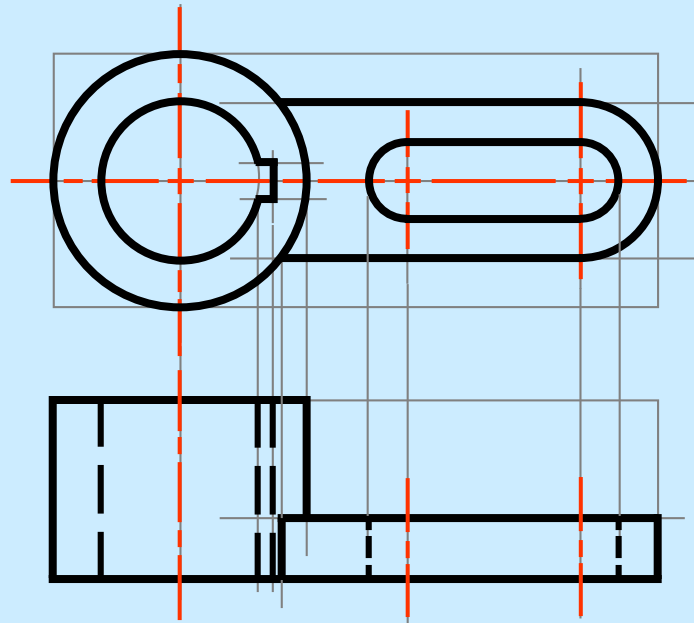
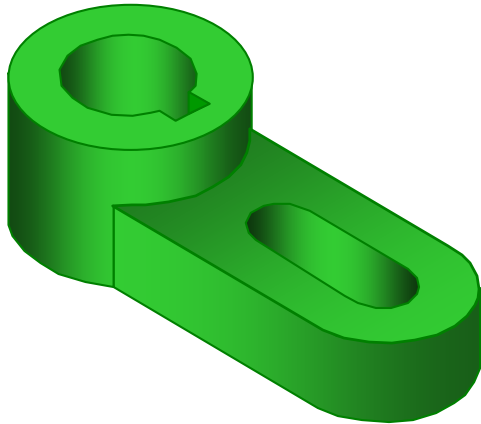

DIMENSION THE VIEWS

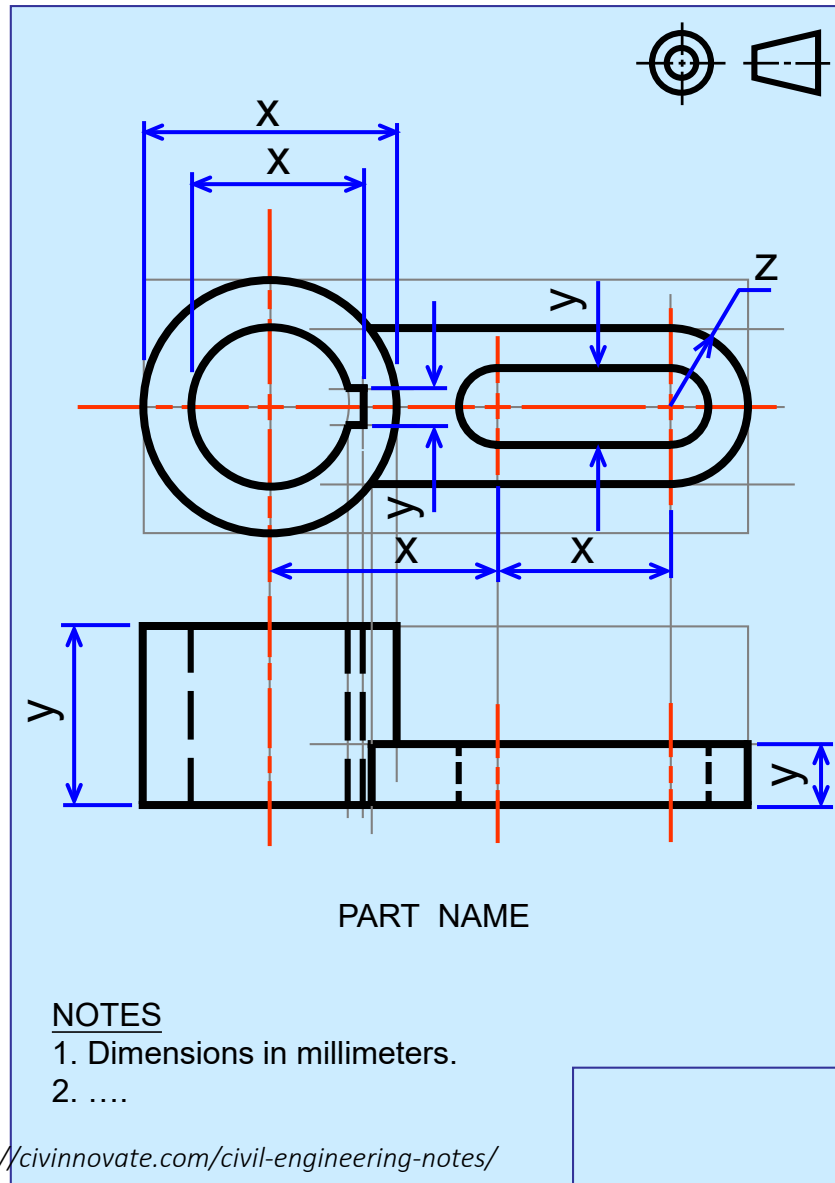
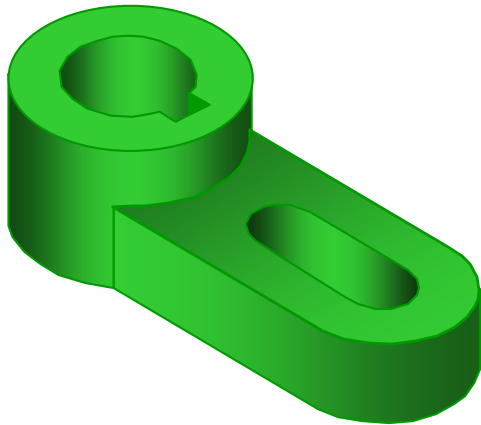

TRANSFERRING THE DEPTH DIMENSION

1. Direct measurement

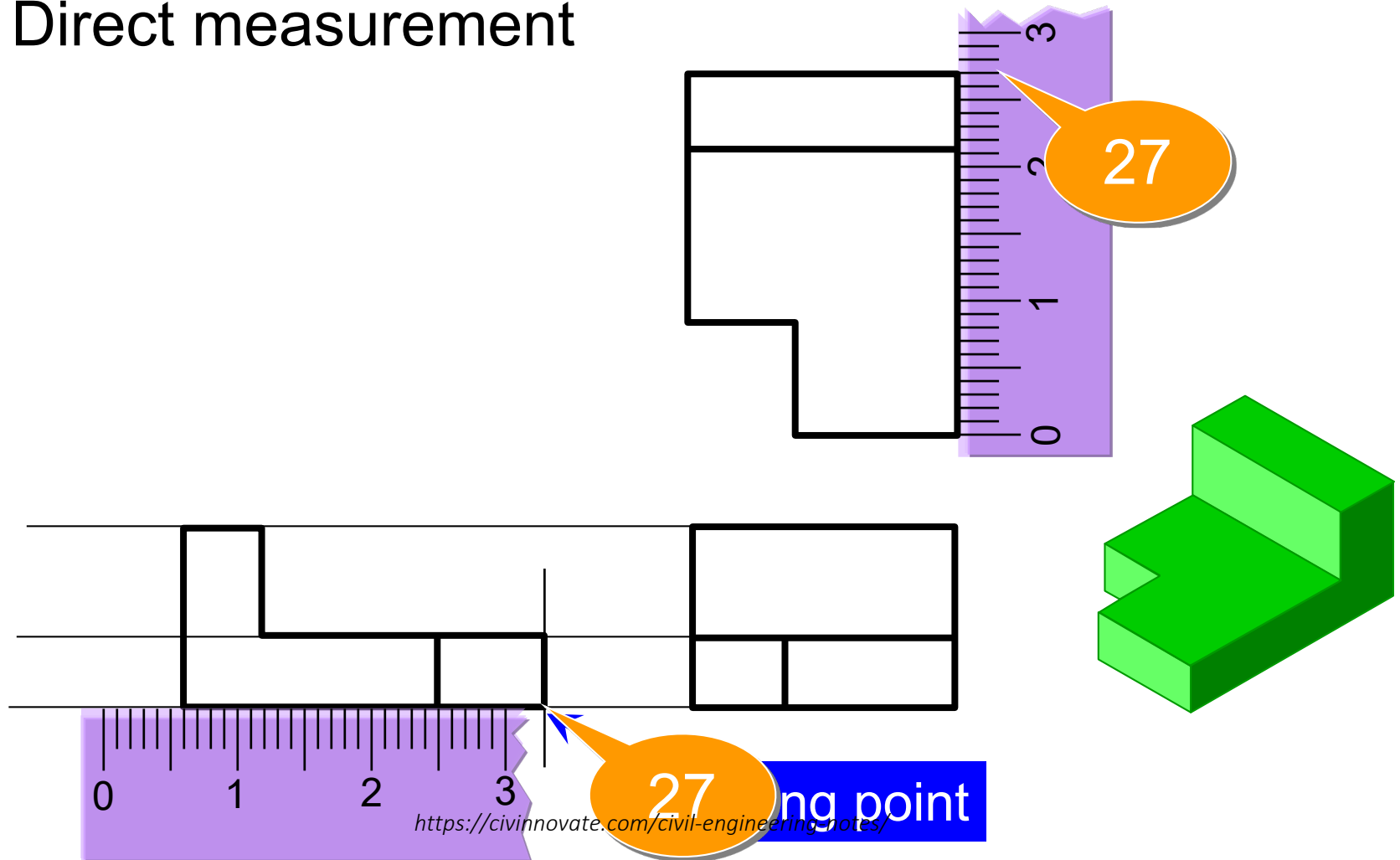

TRANSFERRING THE DEPTH DIMENSION

2. Use miter line

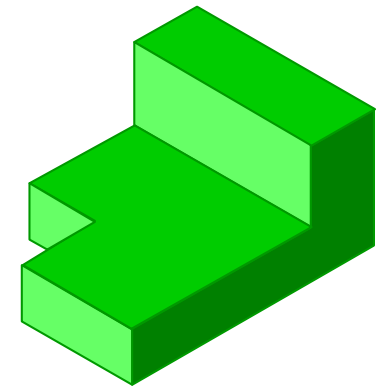
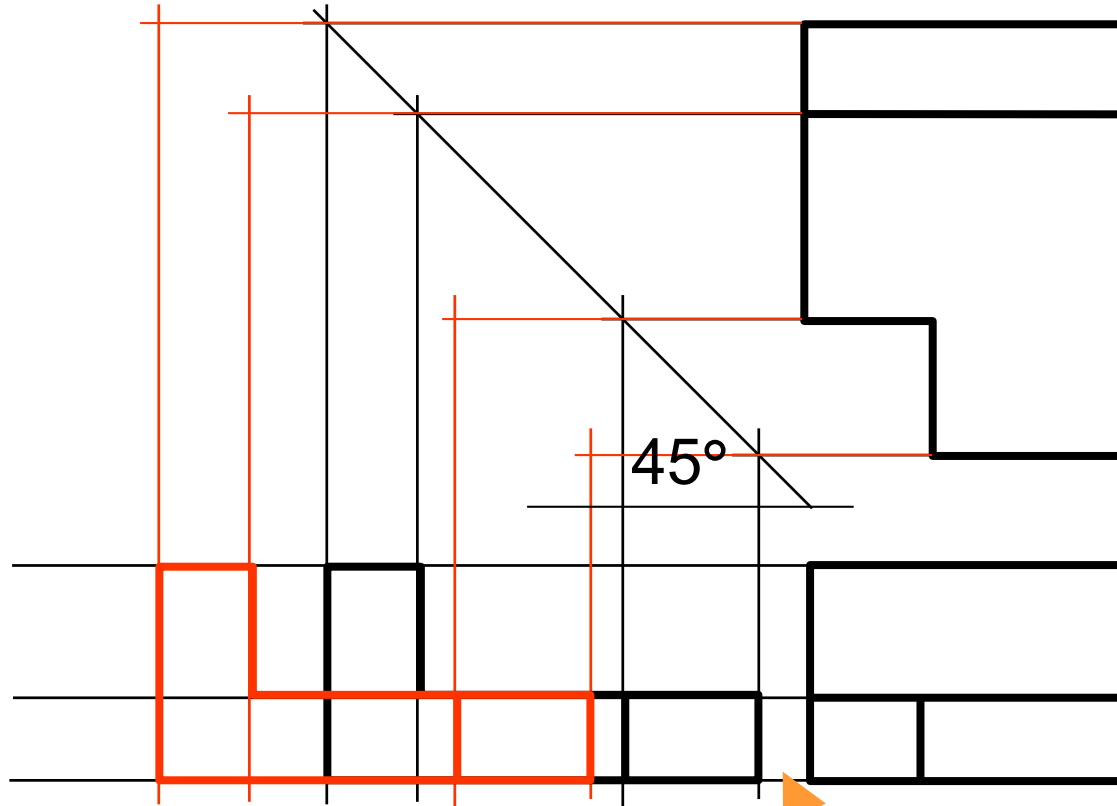

Views too close



Basic Dimensioning



<https://civinnovate.com/civil-engineering-notes/>

COMPONENTS

1. Extension lines
2. Dimension lines
3. Leader lines
4. Dimension numbers
5. Local notes

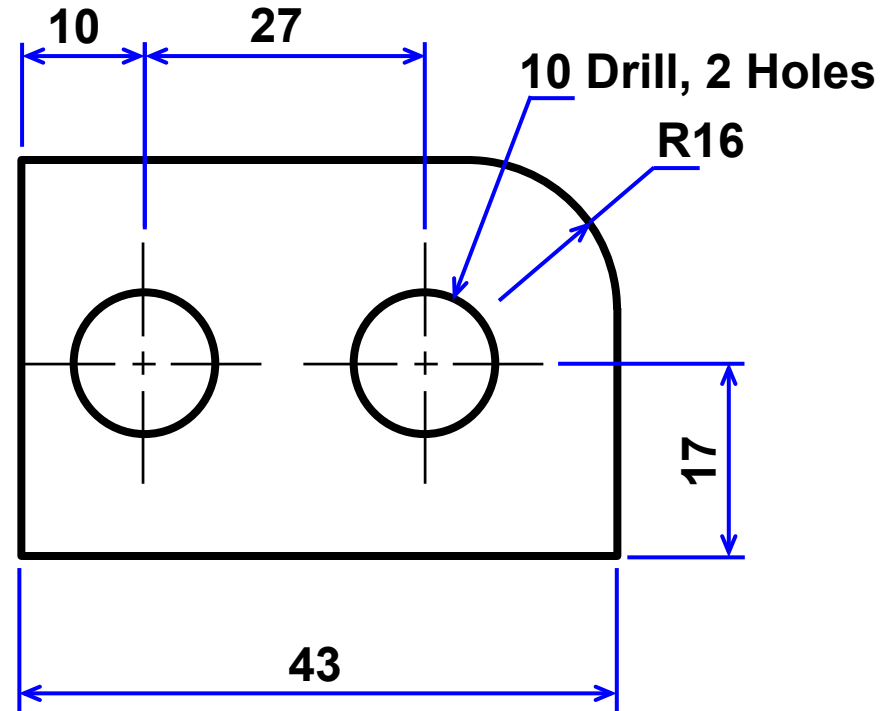



Tangencies and Intersections



<https://civinnovate.com/civil-engineering-notes/>

TANGENT & INTERSECTION

- No line is formed when curved surface *tangent* to a plane surface.
- Line is formed when curved surface *intersects* a plane surface.

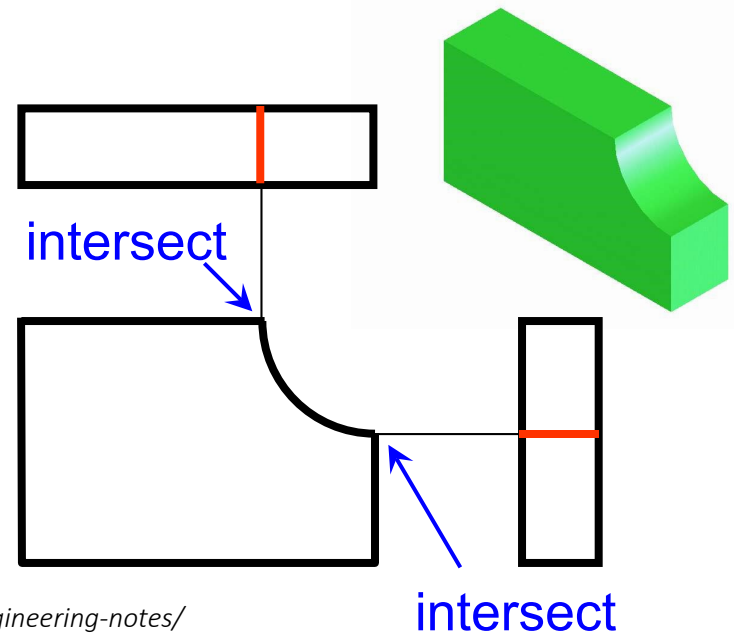
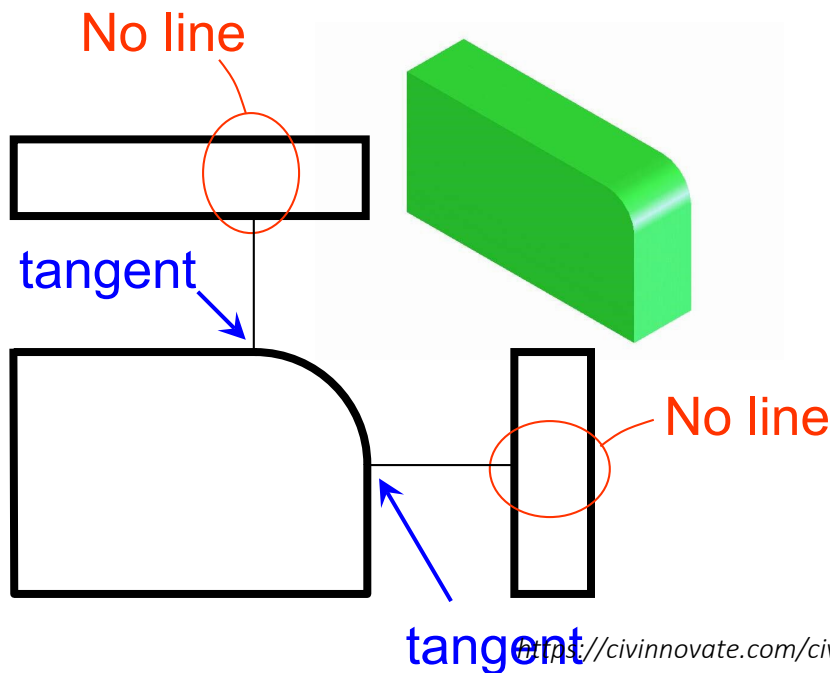

TANGENT & INTERSECTION

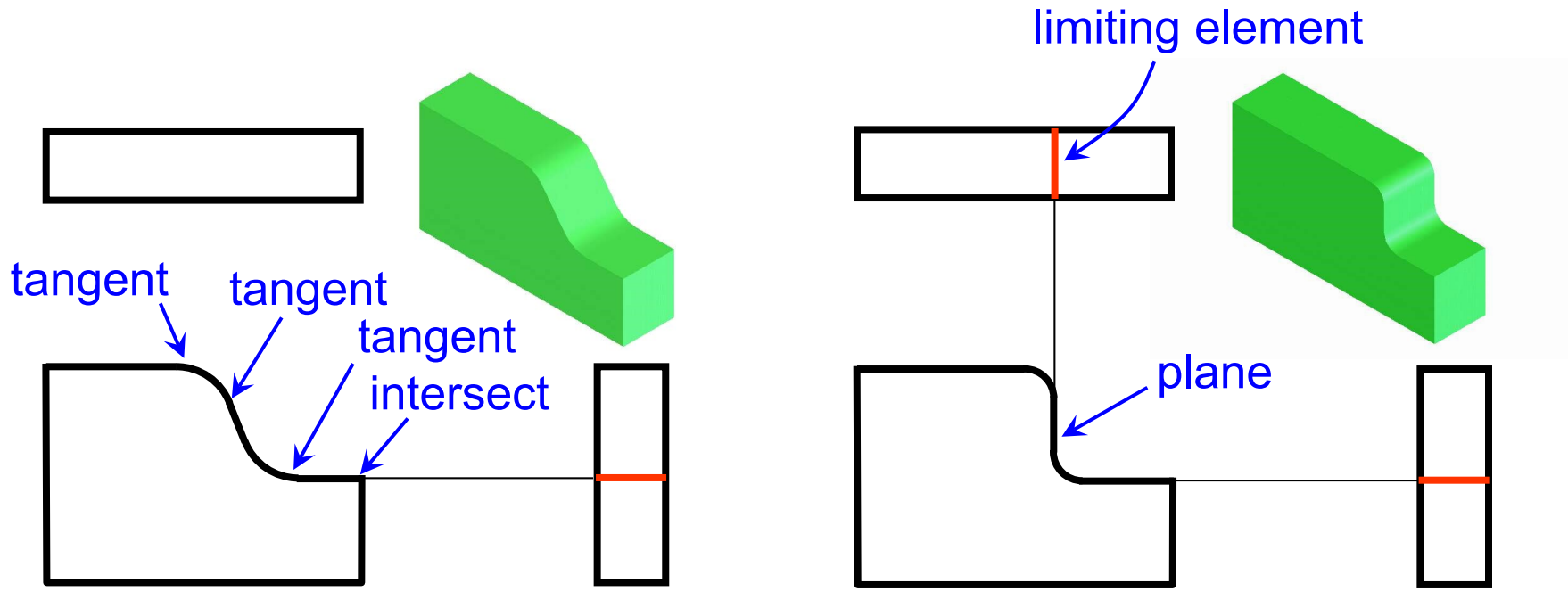

TANGENT & INTERSECTION

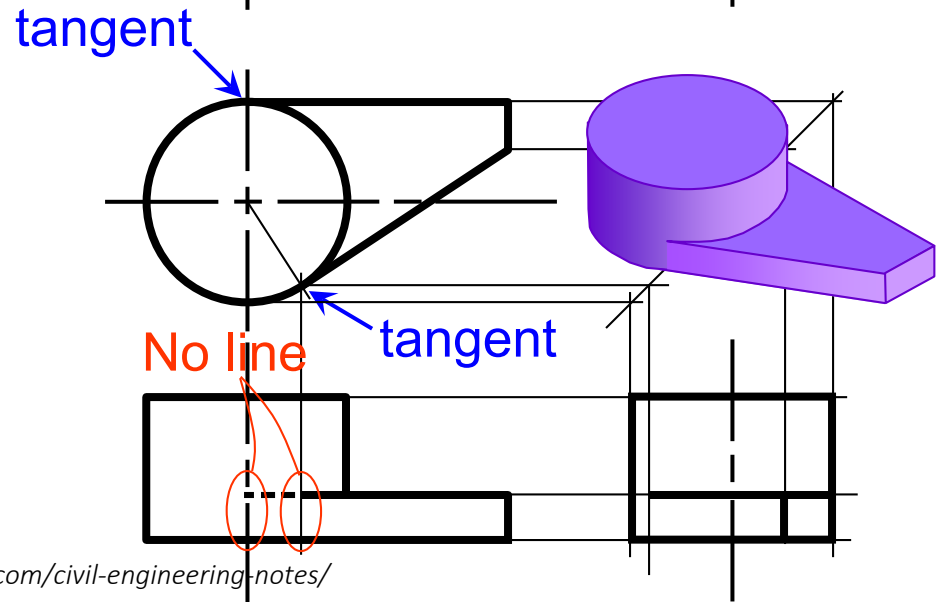
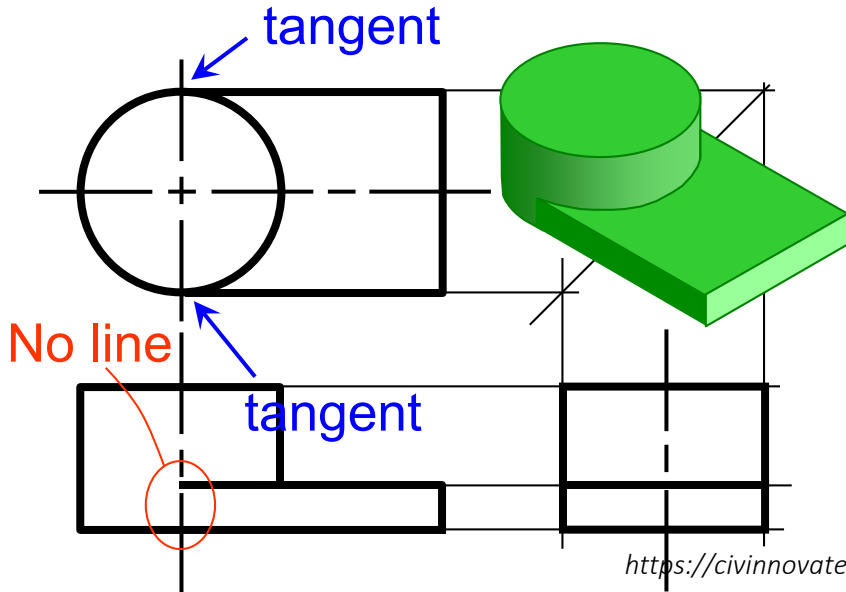
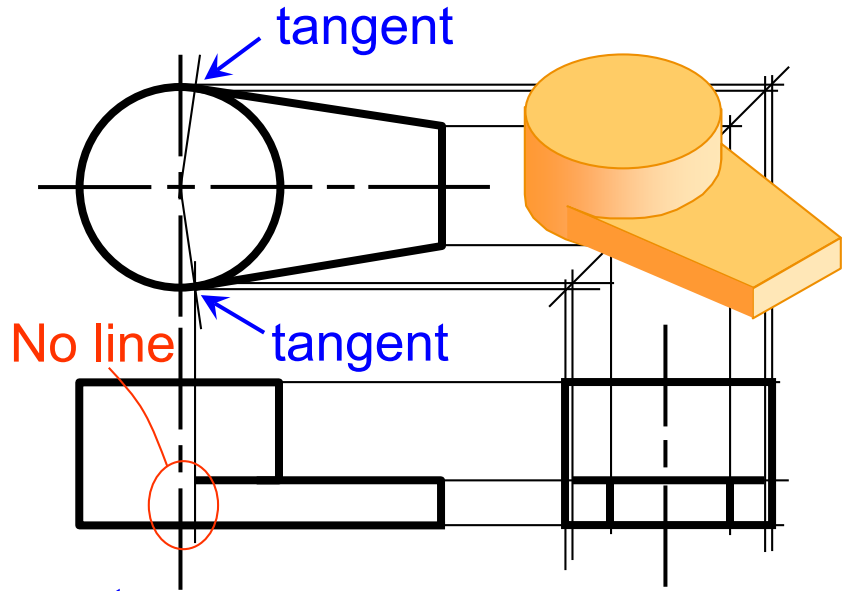
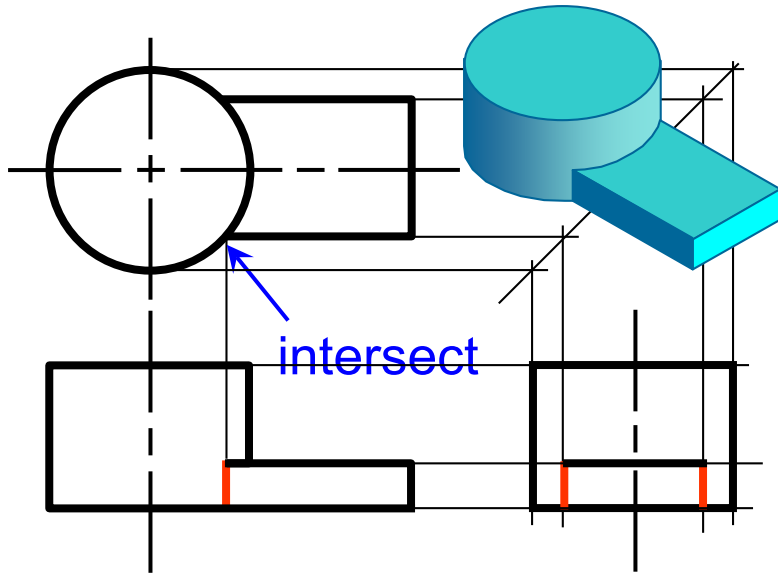

QUIZ

1. Which should be the **natural position** of the light bulb ? (20 sec)

a

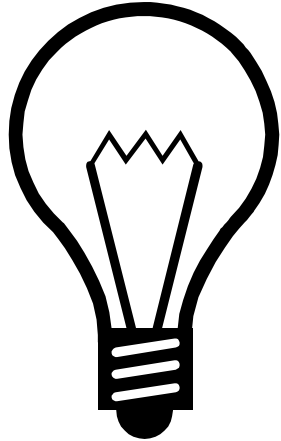

b)

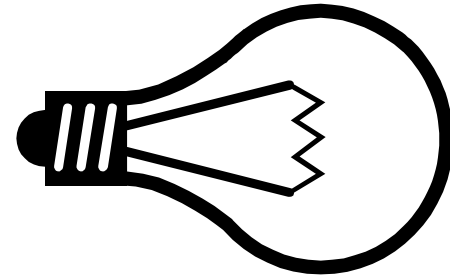

c)

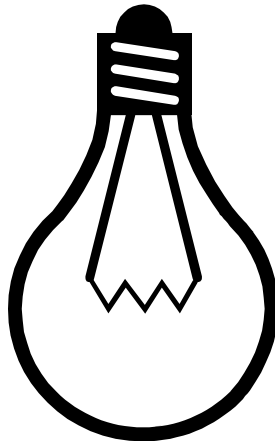

d)

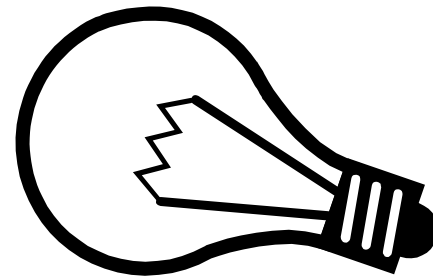

0 5 10 15 20



2. Which are the **necessary views** ? (60 sec)

a) A-C-E

b) E-B-D

c) E-A

d) E-C

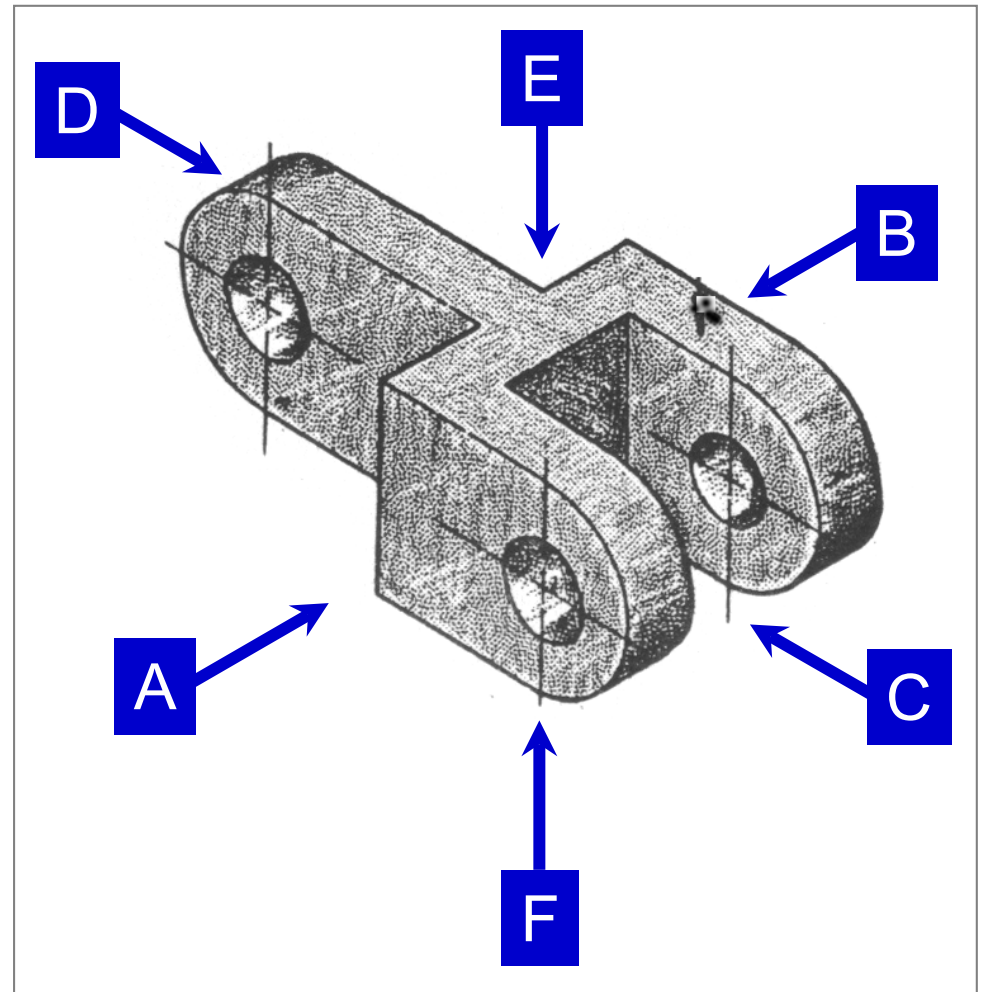

0 15 30 45 60



3. Which is in correct **first** angle projection ? (180 sec)

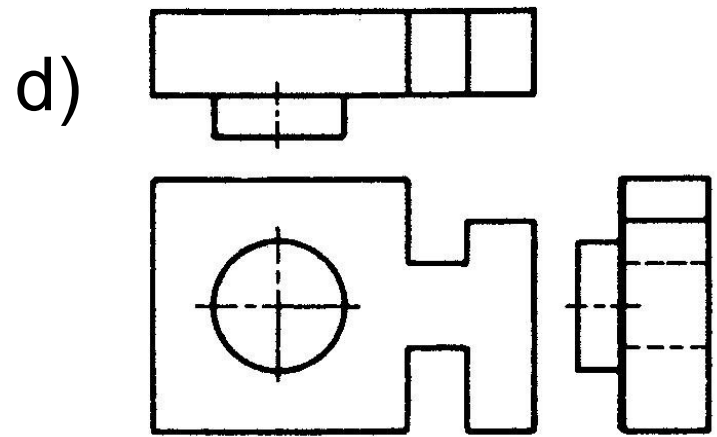
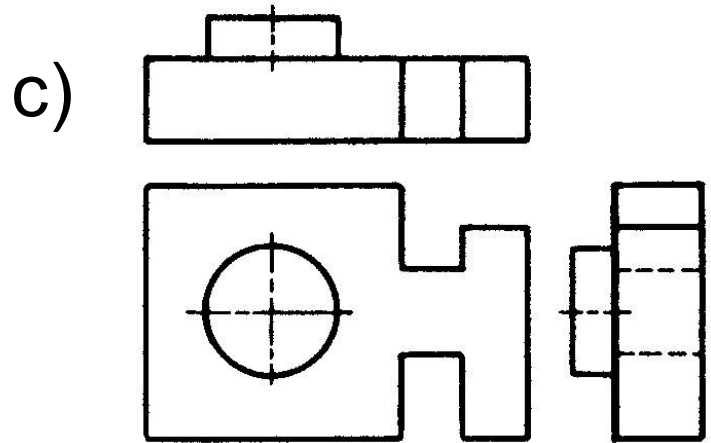
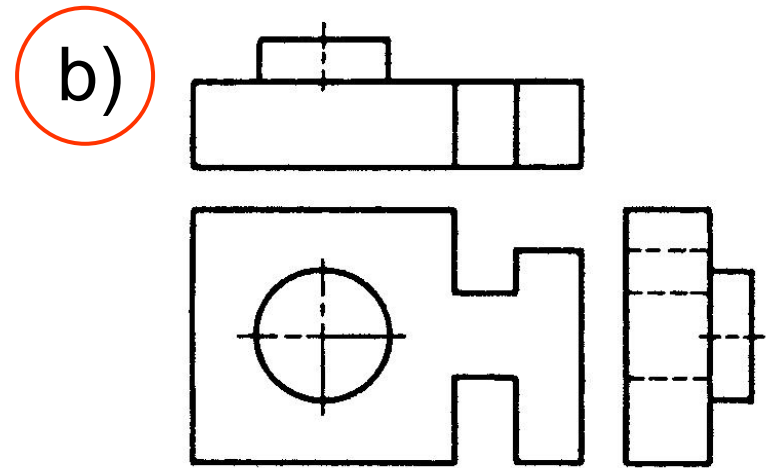
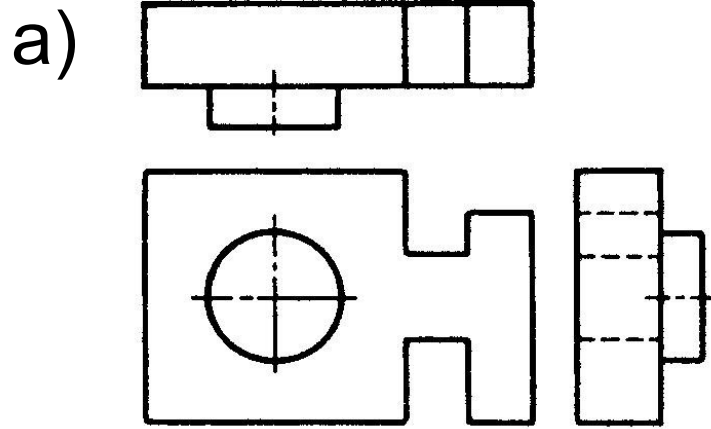

0 45 90 135 180

4. Which is in correct **third** angle projection ? (180 sec)

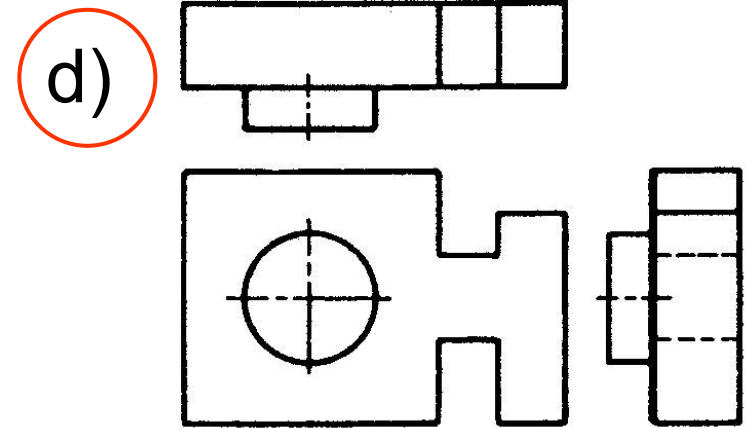
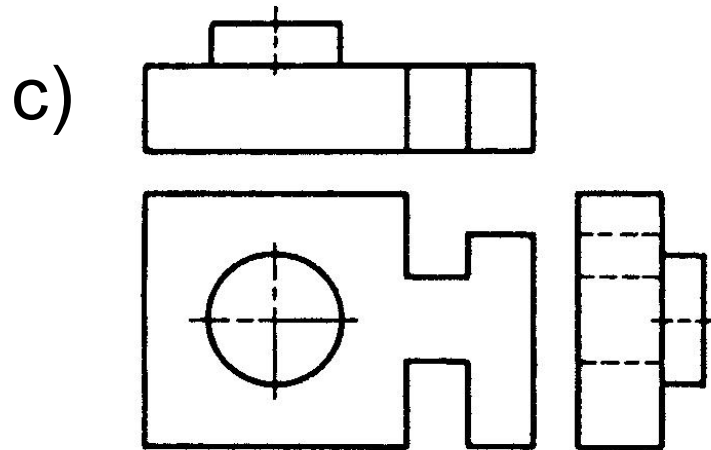
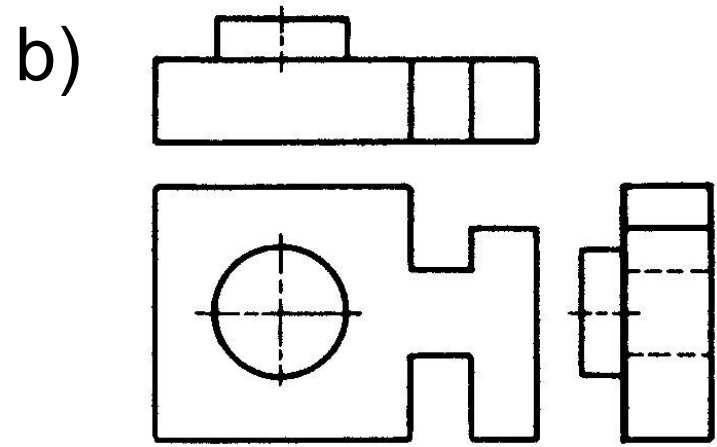
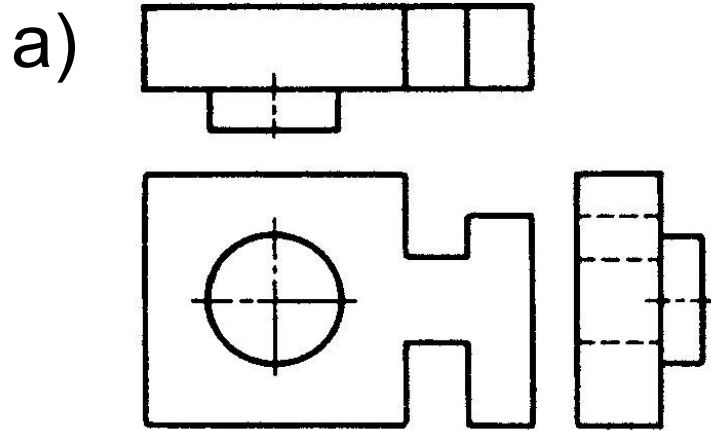

0 45 90 135 180

5. Which is a **wrong** 3rd angle orthographic views ?
(180 sec)

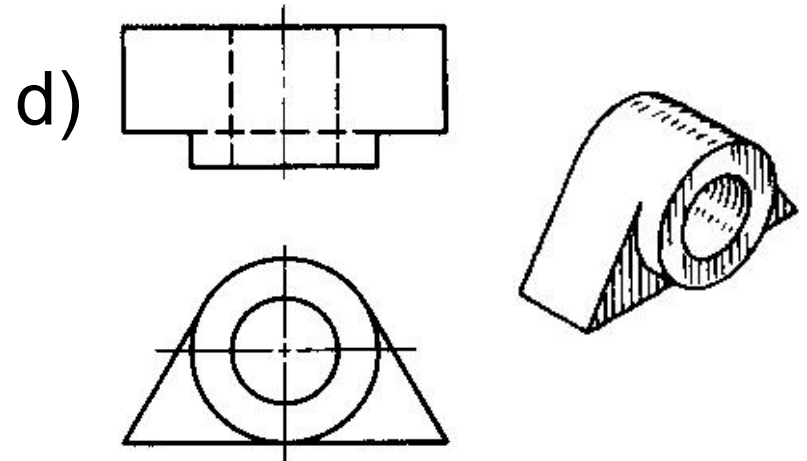
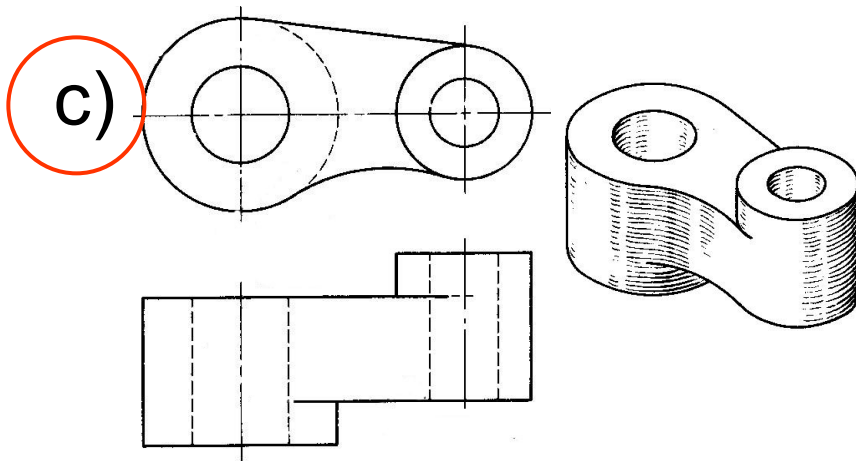
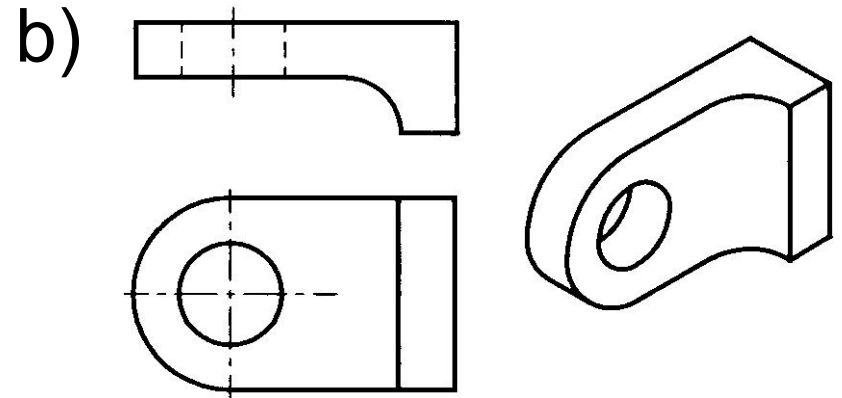
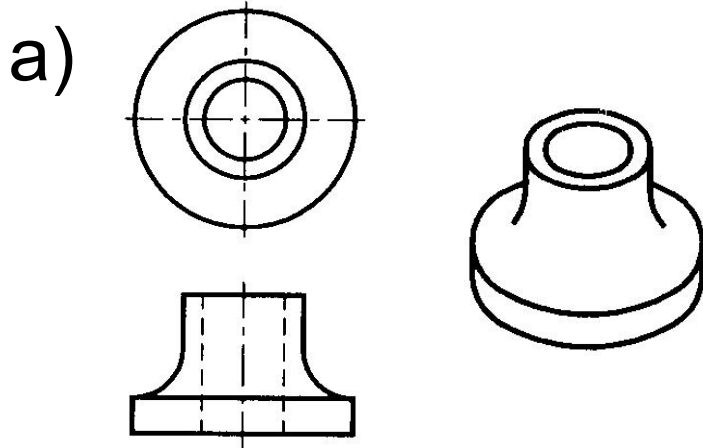

0 45 90 135 180