



# Chapter 2

## Using Drawing Tools & Applied Geometry



<https://civinnovate.com/civil-engineering-notes/>



# TOPICS

---

- Preparation of Tools.
- Using of Tools
- Applied Geometry

# Preparation of Tools

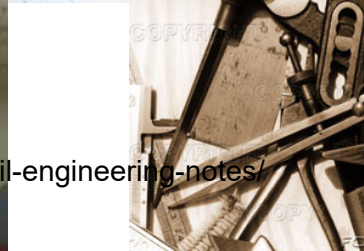
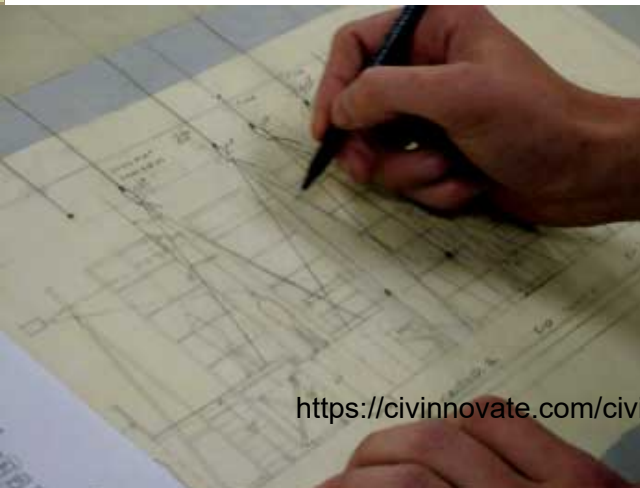
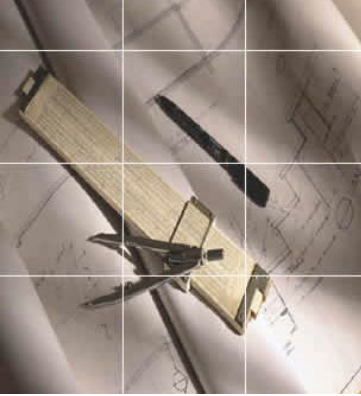

# Fastening Paper to Drafting Board

1. Place the paper close to the table's left edge.
2. Move the paper until its lower edge place about the top edge of T-square.



# Fastening Paper to Drafting Board

3. Align the top edge of the paper with T-square blade.
4. Attach the paper's corners with tape.

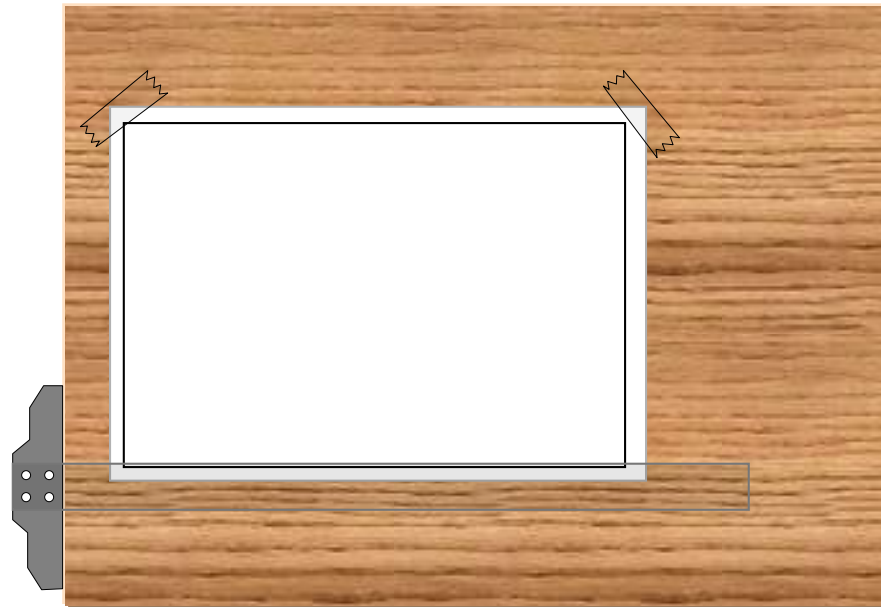

# Fastening Paper to Drafting Board

5. Move T-square down to smooth the paper.
6. Attach the remaining paper's corners with tape.

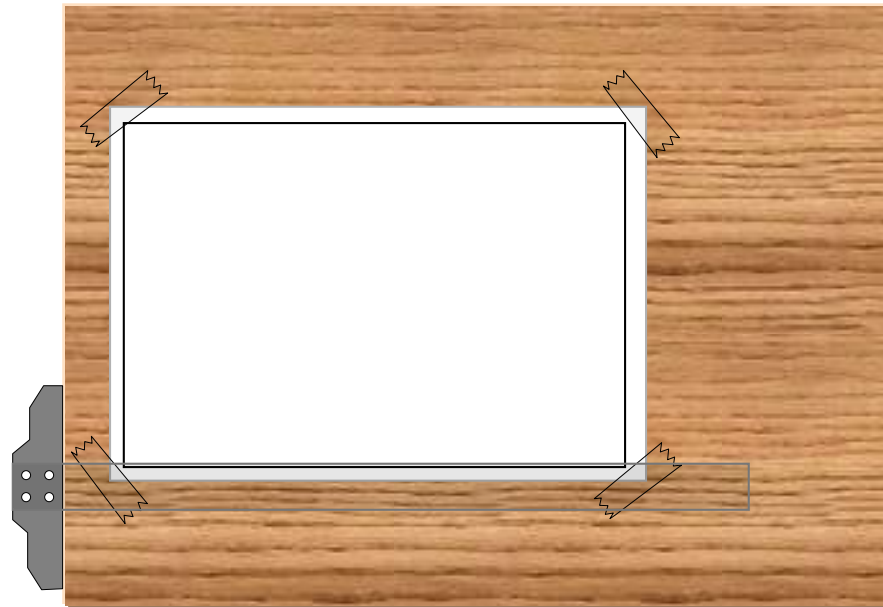

# Sharpening the Pencil

1. Remove the wood with penknife while expose a lead about 8-10 mm.
2. Polish the lead into a conical shape with a sandpaper.
3. Clean the lead with tissue paper.

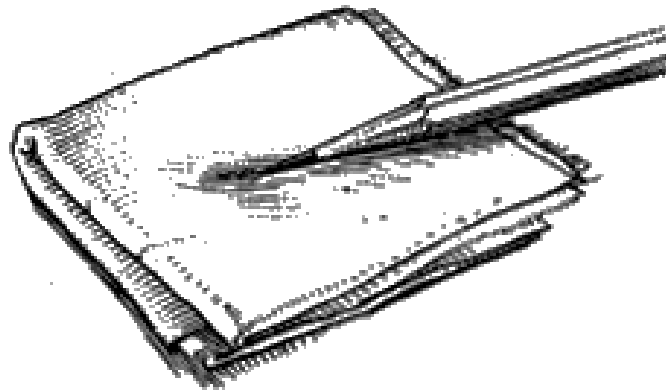



# Preparing the Compass

1. Sharpen the lead with a sandpaper.
2. Adjust the **needle** and the **lead** so that the tip of the needle extends slightly more than the lead.

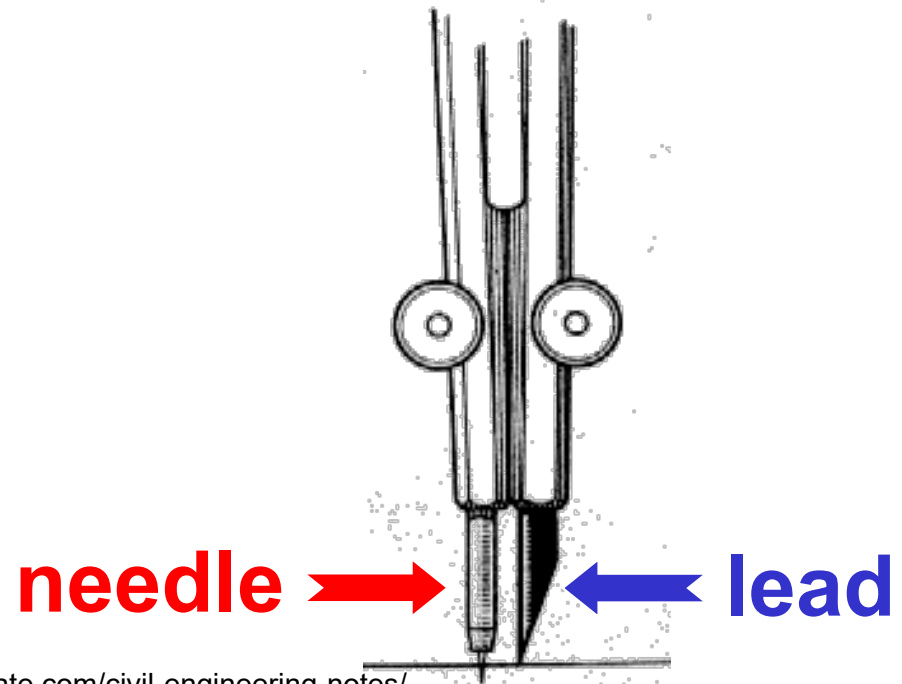
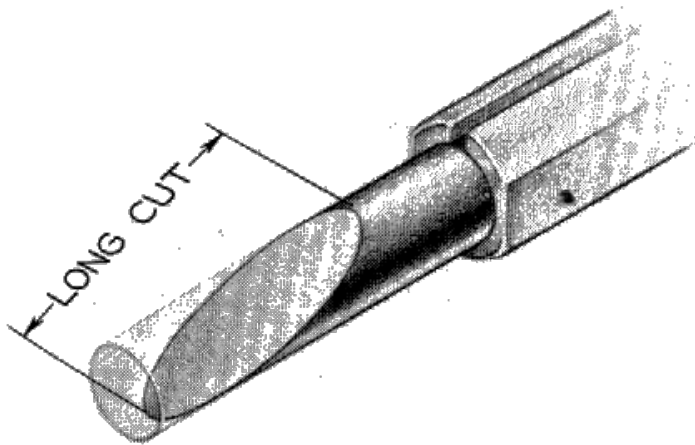



# Using the Tools

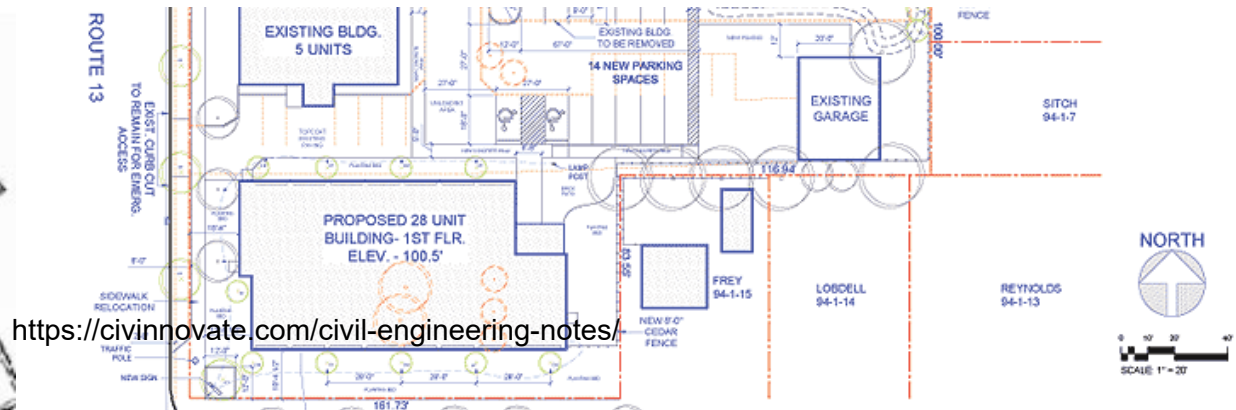

<https://civinnovate.com/civil-engineering-notes/>

# Function of the Tools

## Tools

1. T-square
2. Triangles
3. Compass
4. Circle template

## Shape to be drawn



Straight line



Arc, Circle

# Using the Compass

1. **Locate the center** of the circle by two intersecting lines.
2. Adjust the distance between needle and lead to a distance equal to radius of the circle.
3. Set the needle point at center.

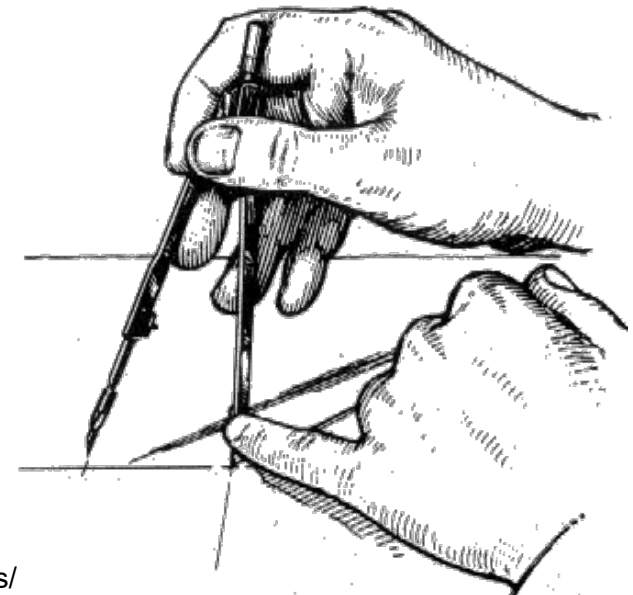
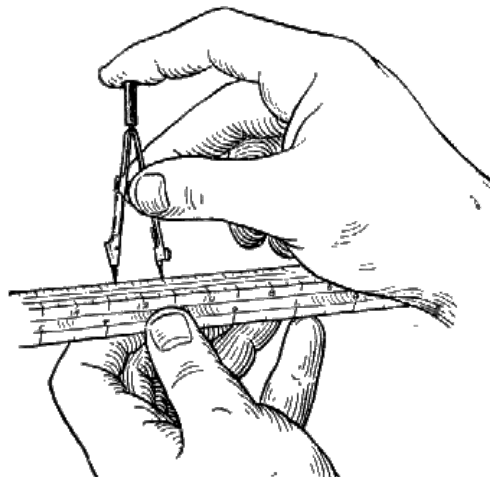
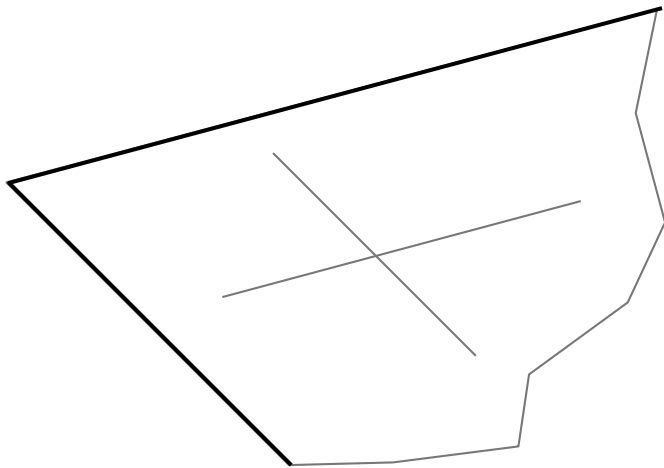

# Using the Compass

4. **Start circle.** Apply enough pressure to the needle, holding compass handle between thumb and index fingers.
5. **Complete circle.** Revolve handle clockwise.

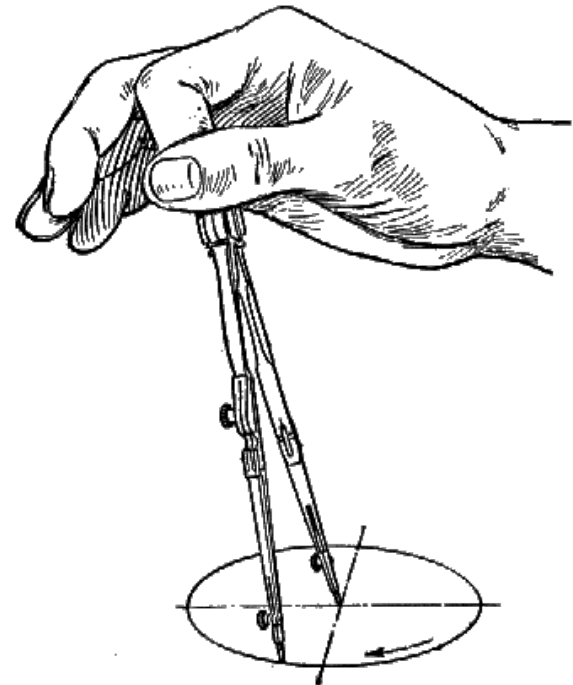
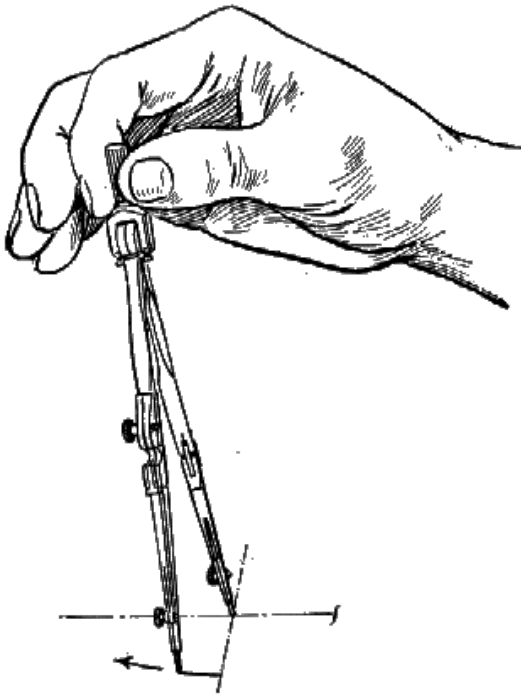

# Using a Circle Template

1. Draw two perpendicular lines that pass through center of a circle to be drawn.
2. Place the template till all marking coincide with center lines.
3. Tracing the circle. (Hold the pencil normal to the paper.)

**Given**

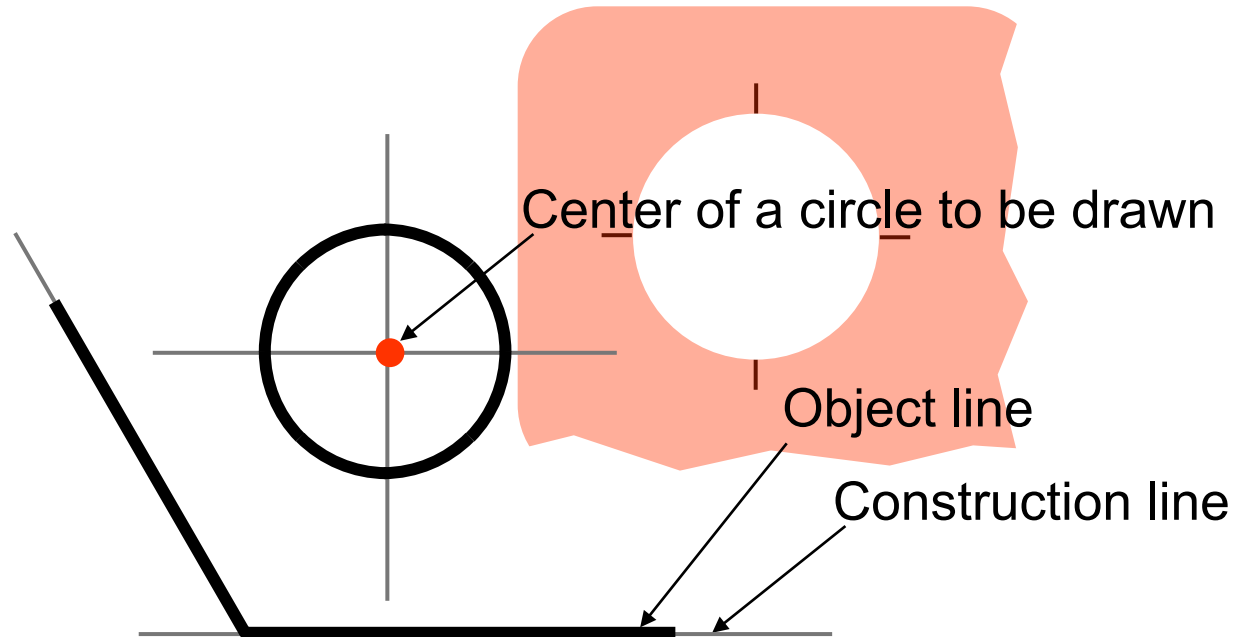

# Draw a Horizontal Line

1. Press the T-square head against the left edge of the table.
2. Smooth the blade to the right.

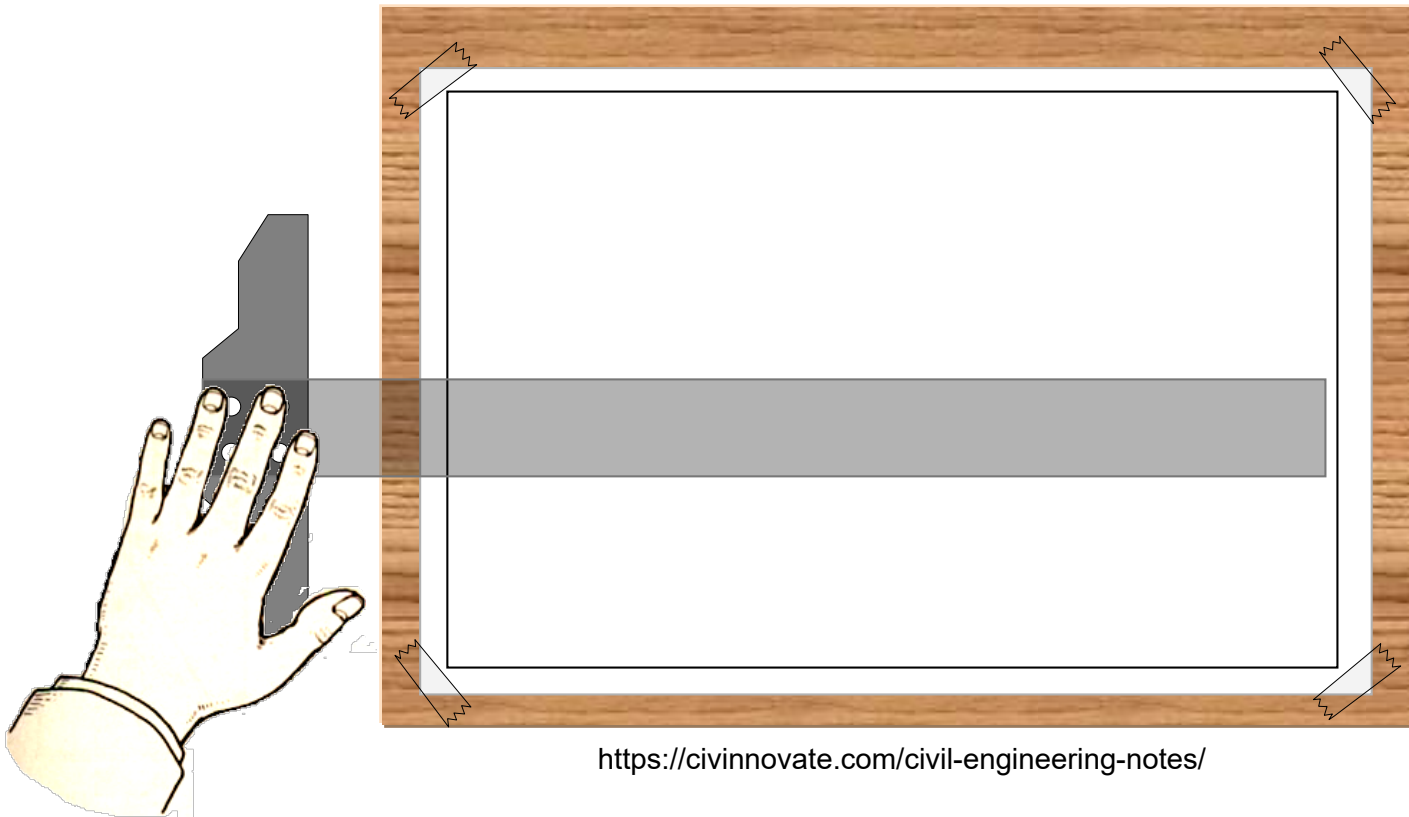

# Draw a Horizontal Line

3. Lean the pencil at an angle about  $60^\circ$  with the paper in the direction of the line and slightly “toed in”.
4. Draw the line from left to right while **rotating the pencil slowly**.

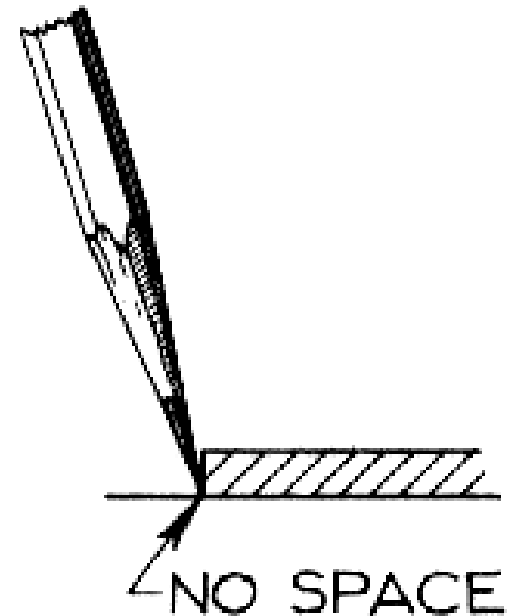
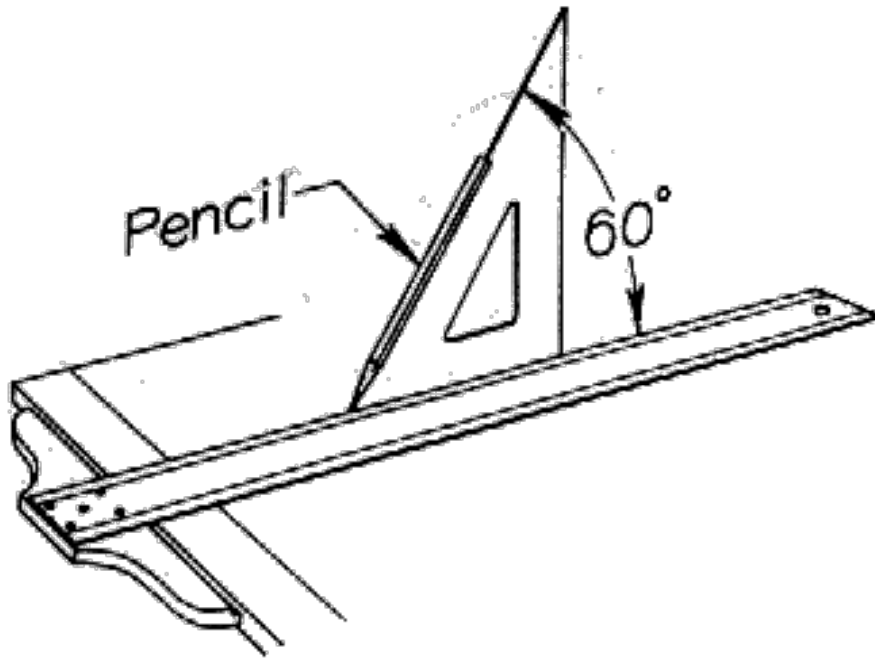



# Draw a Vertical Line

1. Set T-square as before. Place any triangle on T-square edge.
2. Slide your left hand to hold both T-square and triangle in position.

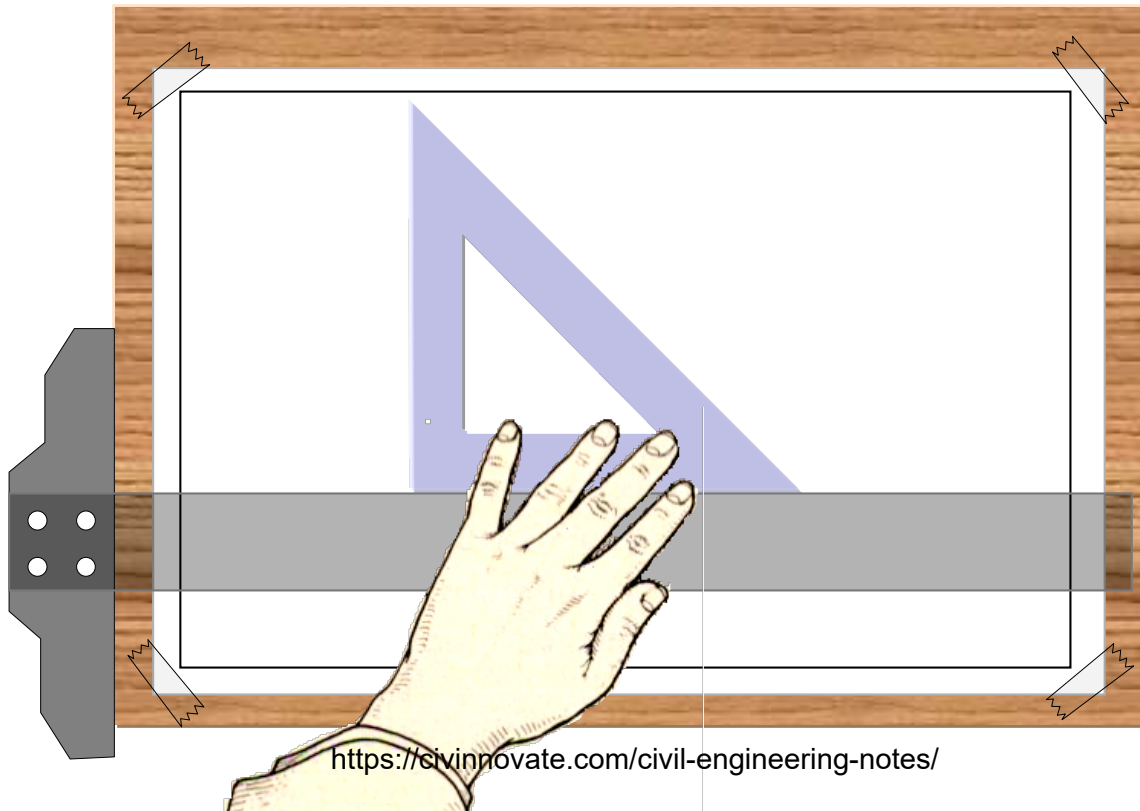

# Draw a Vertical Line

3. Lean the pencil to the triangle.
4. Draw the line upward while **rotating the pencil slowly**.

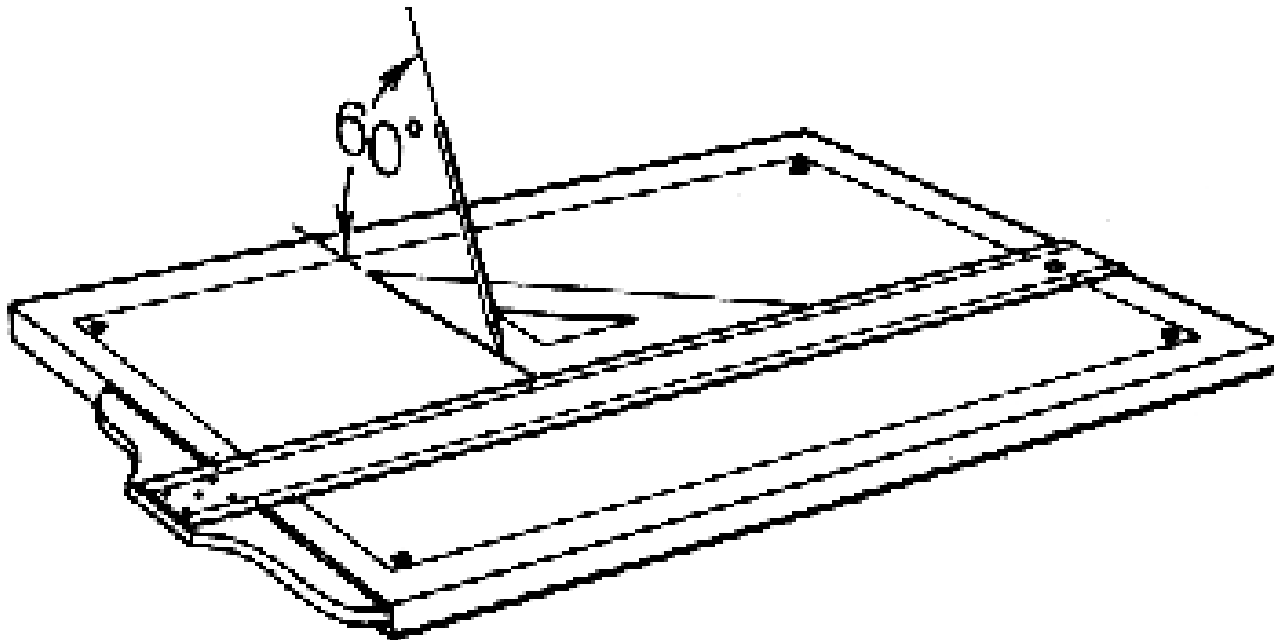

# Draw a line at 45° with horizontal

1. Place 45° triangle on the T-square edge and press them firmly against the paper.
2. Draw the line in the direction as shown below.

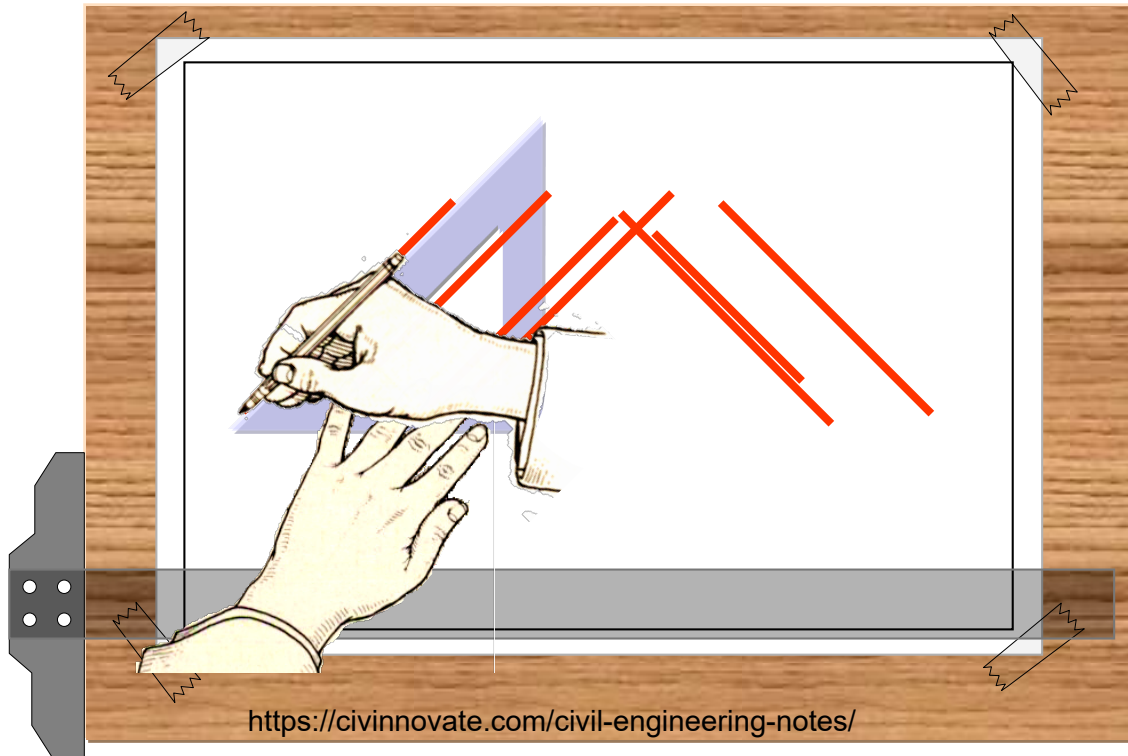

# Draw a line at angle 30° and 60°

1. Place 30°-60° triangle on the T-square edge and press them firmly against the paper.
2. Draw the line in the direction as shown below.

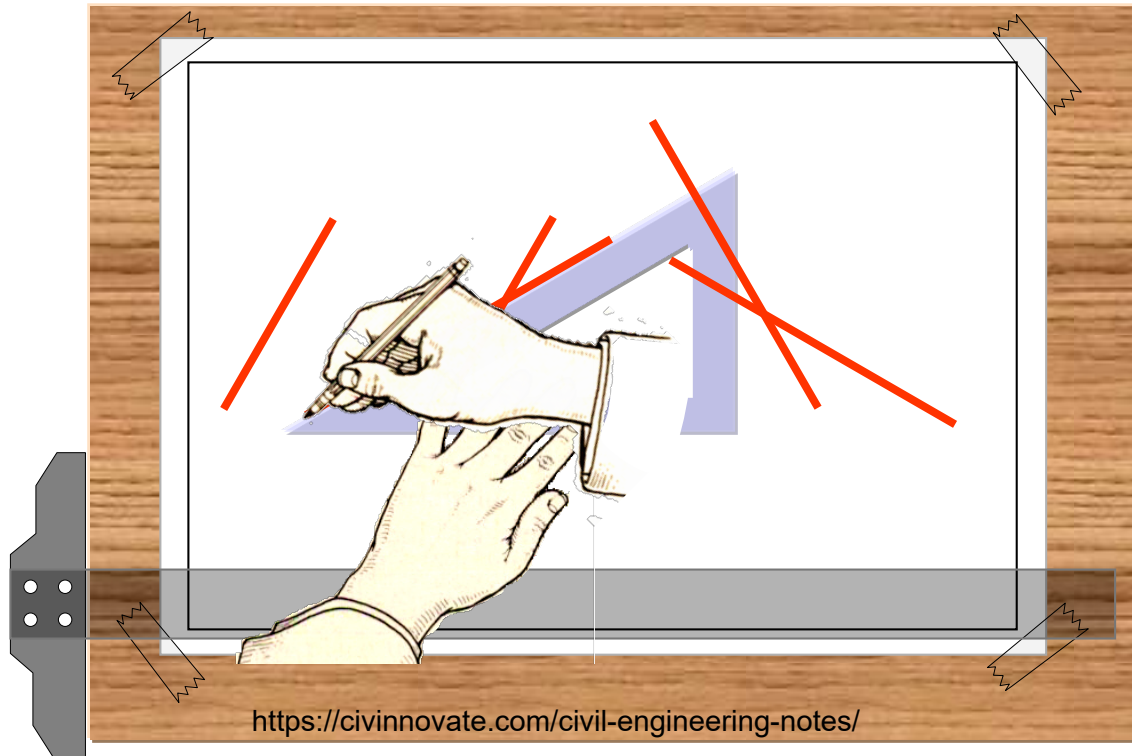

# Draw the lines at 15° increment

0 deg.

15 deg. =  $-30 + 45$  deg

30 deg.

45 deg.

60 deg.

75 deg. =  $30 + 45$  deg

90 deg.

Already  
demonstrated.

Already  
demonstrated.

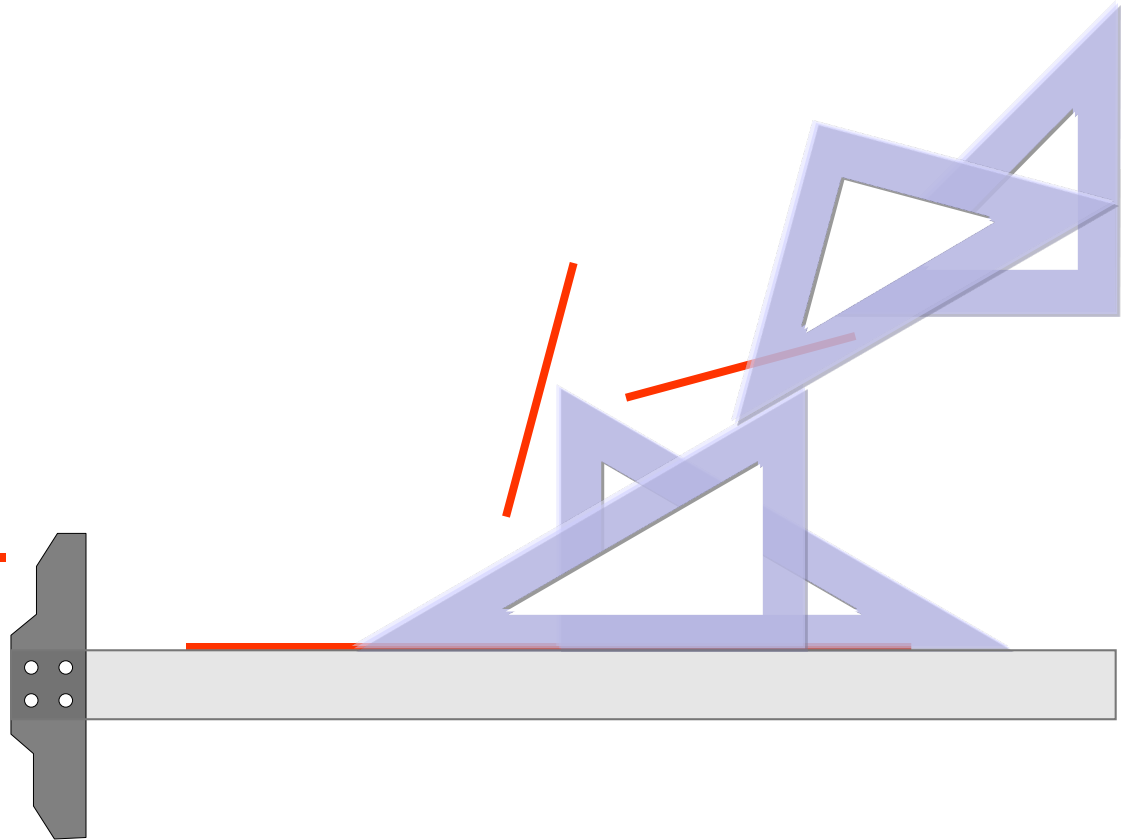

# Draw the line passing through two given points

1. Place the pencil tip at one of the points.
2. Place the triangle against the pencil tip.
3. Swing the triangle around the pencil tip until its edge align with the second point.
4. Draw a line.

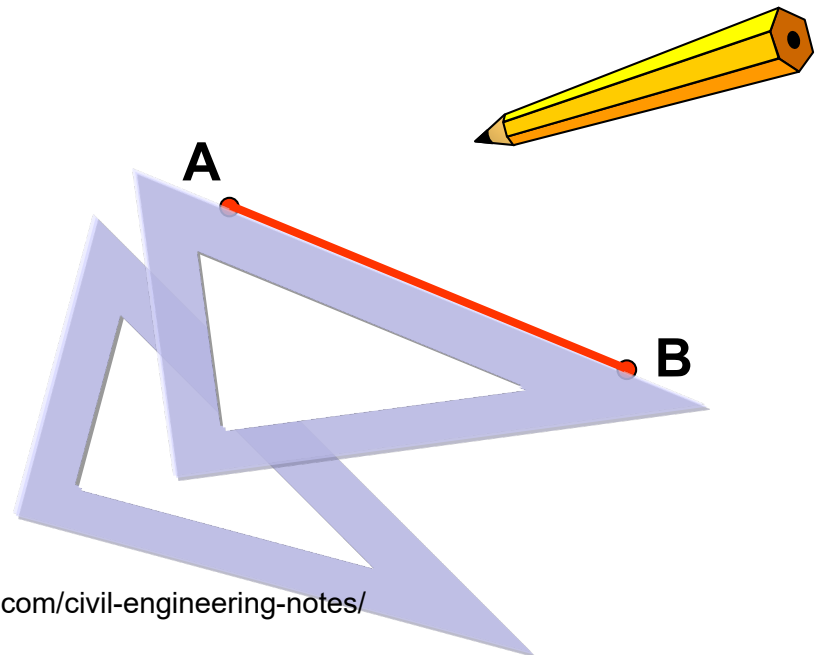
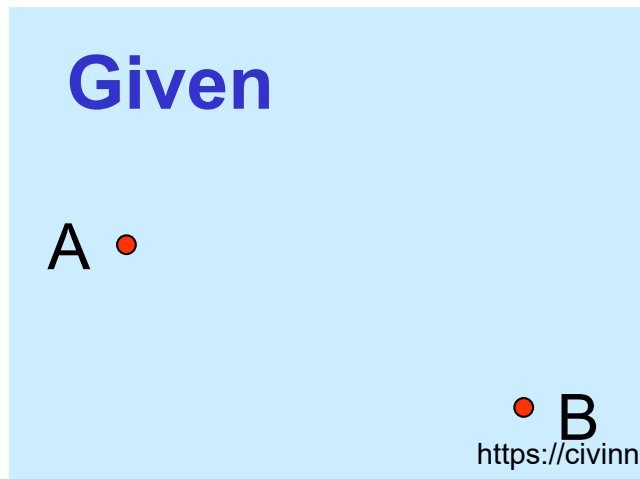



# Applied Geometry

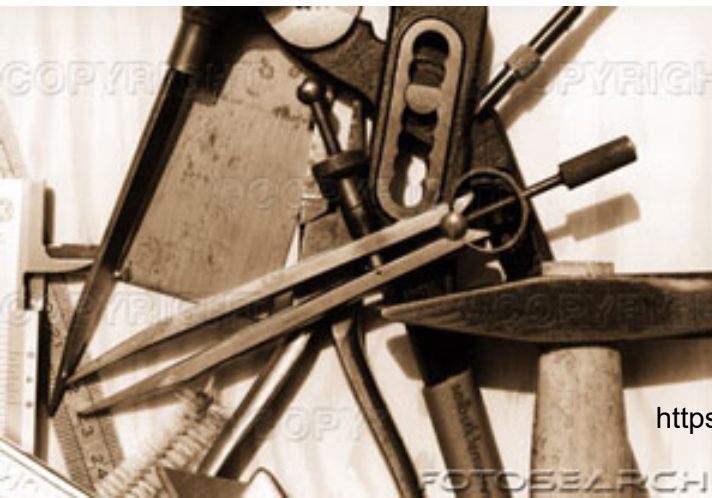

<https://civinnovate.com/civil-engineering-notes/>



# To Bisect a Line

1. Swing two arcs of any radius greater than half-length of the line with the centers at the ends of the line.
2. Join the intersection points of the arcs with a line.
3. Locate the midpoint.

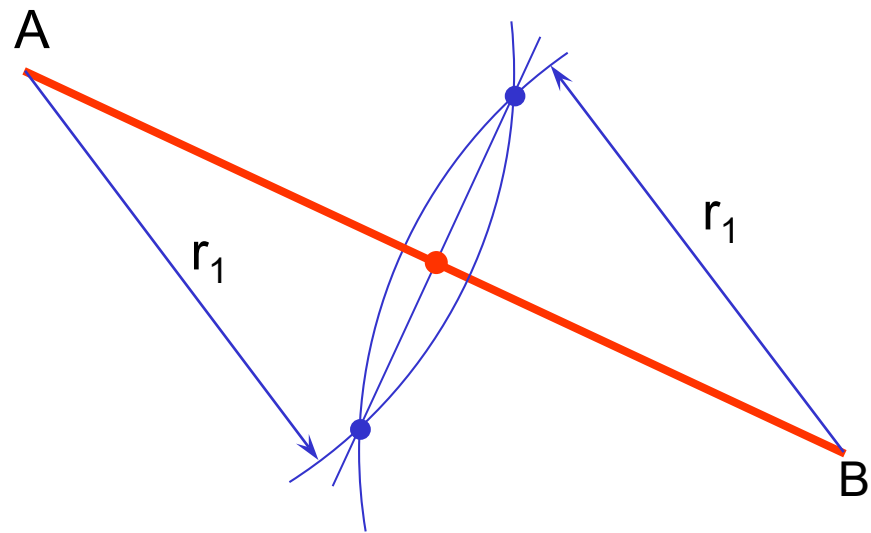
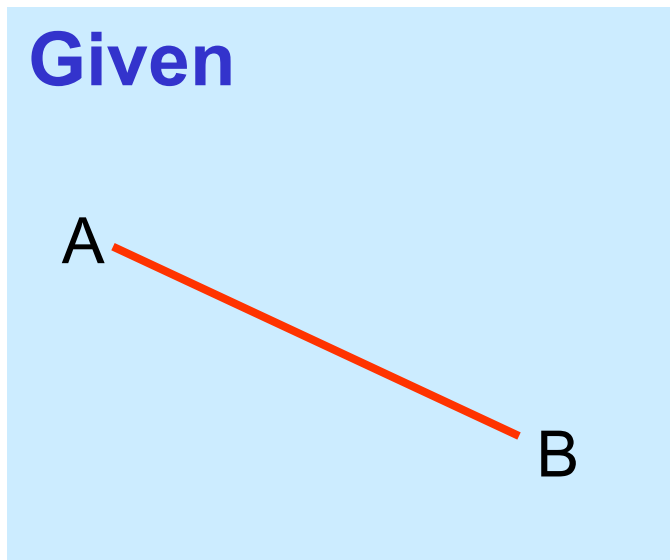



# To Bisect an Angle

1. Swing an arc of any radius whose centers at the vertex.
2. Swing the arcs of any radius from the intersection points between the previous arc and the lines.
3. Draw the line.

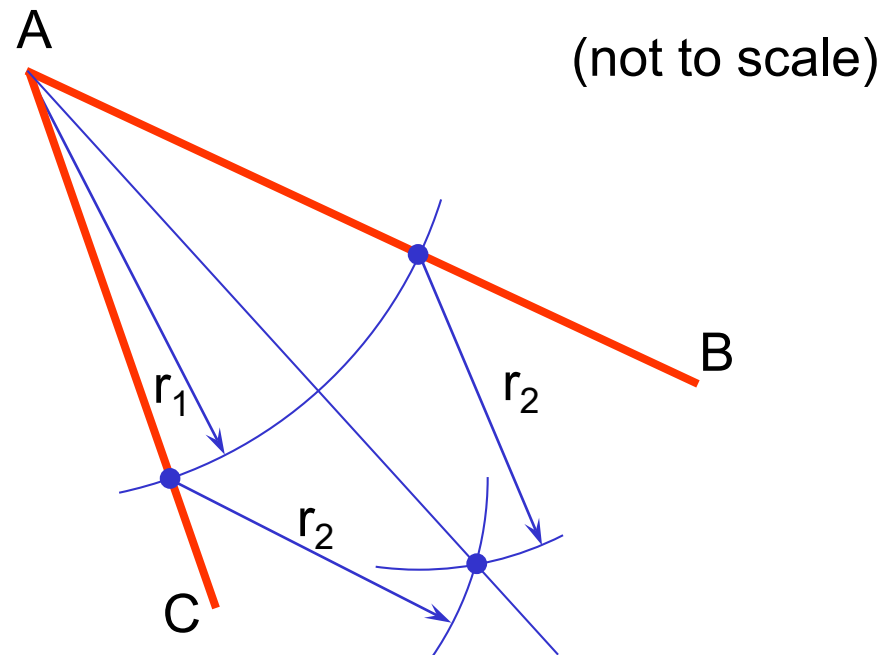
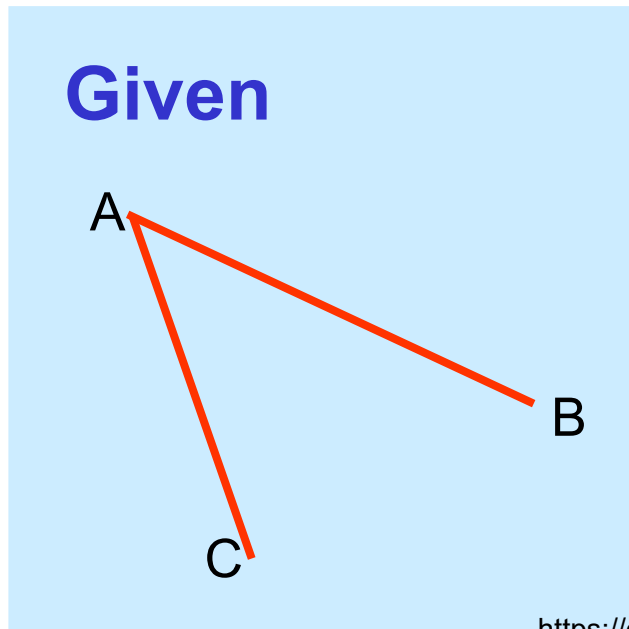

# To draw the line parallel to a given line and passes through a given point

**Given**

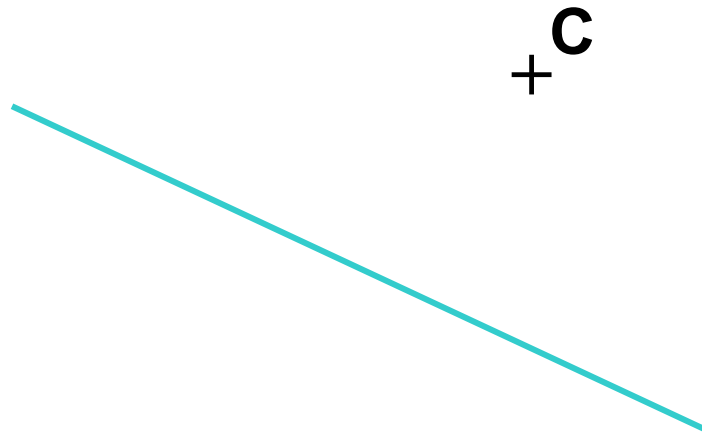

# To draw the line parallel to a given line and passes through a given point

**Given**

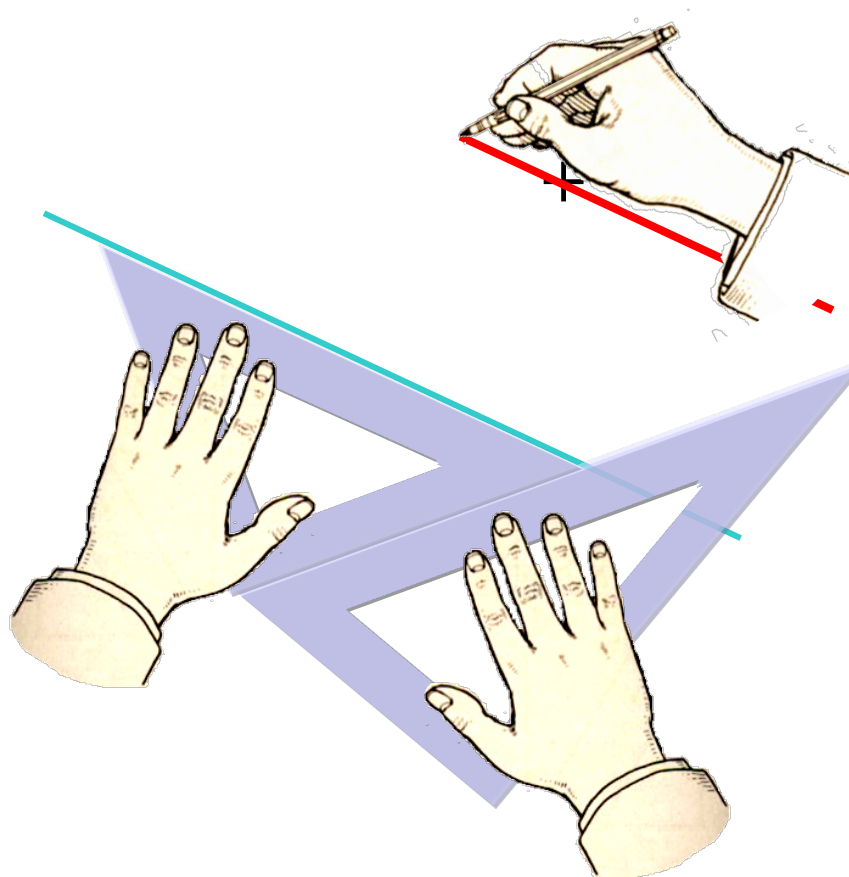

<https://civinnovate.com/civil-engineering-notes/>



**Repeat**

# To draw the line parallel to a given line with a specified distance

**Given distance =  $r$**

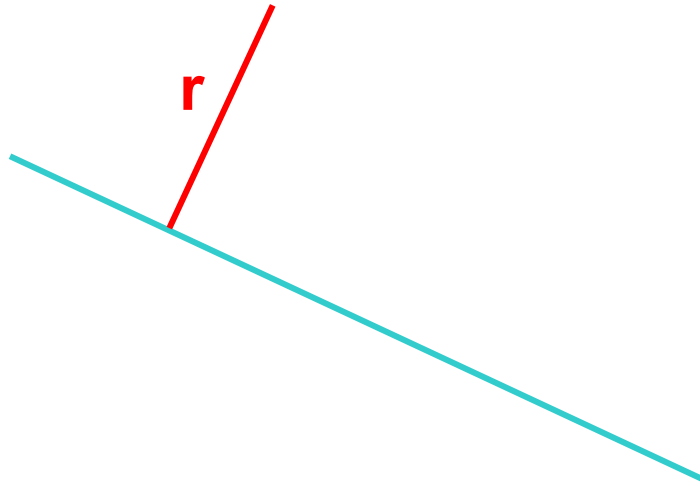

# To draw the line parallel to a given line with a specified distance

**Given distance =  $r$**

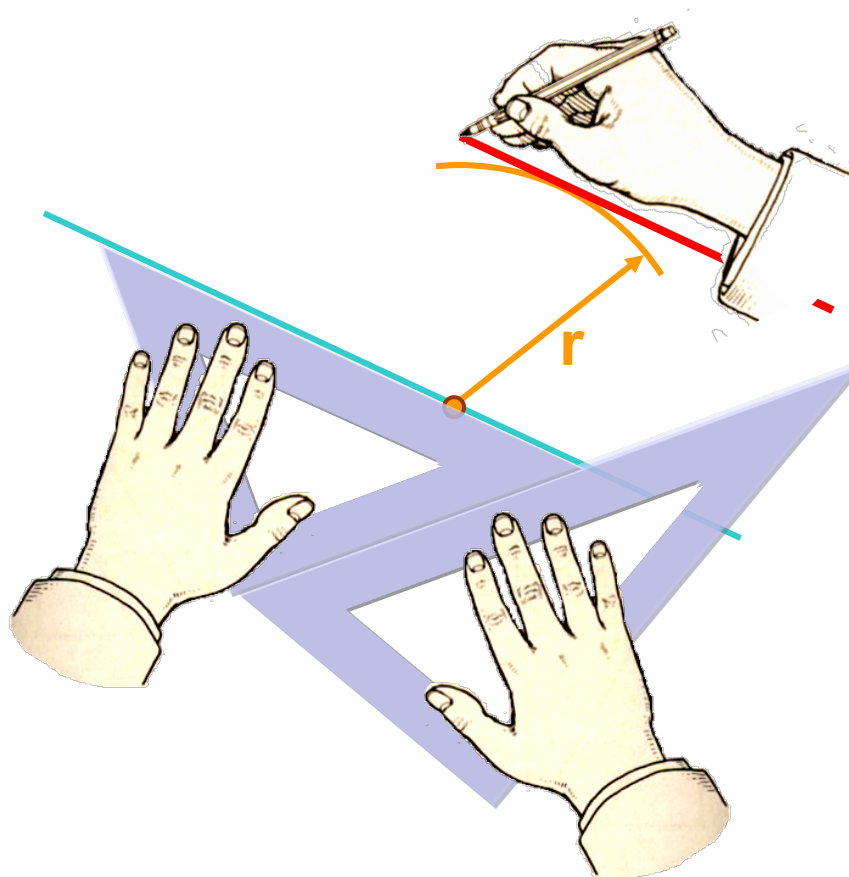

# To draw the line perpendicular to a given line at a given point

## Revolve method

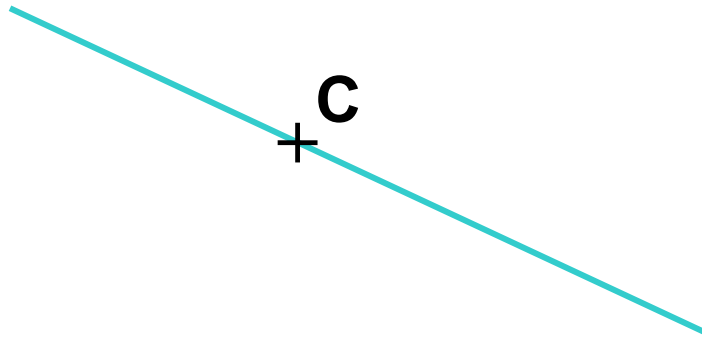

# To draw the line perpendicular to a given line at a given point

## Revolve method

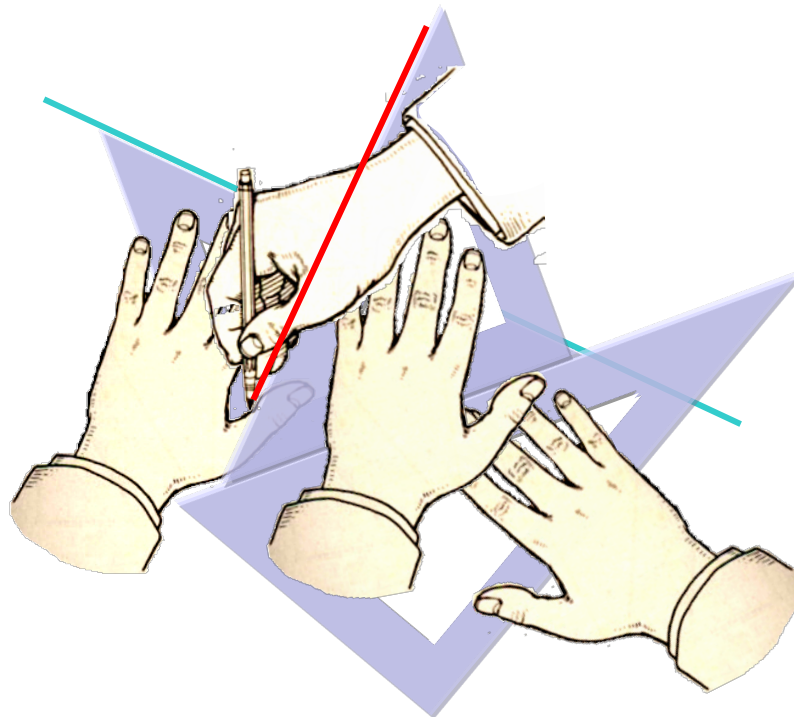

<https://civinnovate.com/civil-engineering-notes/>



Repeat

# To draw the line perpendicular to a given line at a given point

## Adjacent-sides method

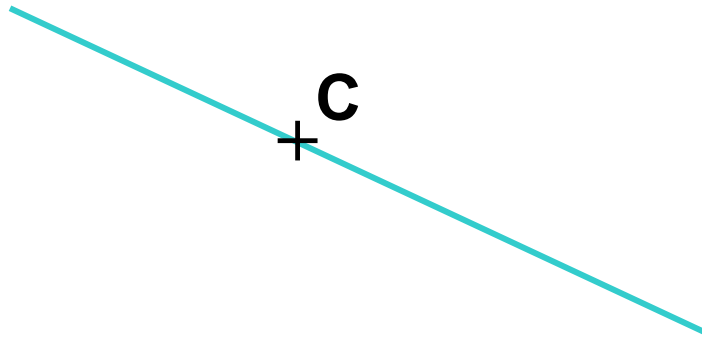



# To draw the line perpendicular to a given line at a given point

## Adjacent-sides method

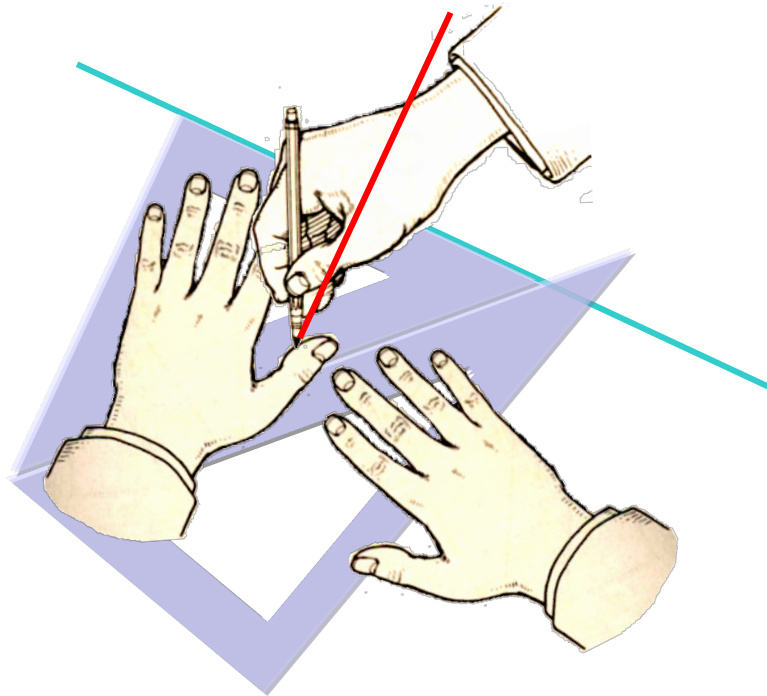

<https://civinnovate.com/civil-engineering-notes/>



Repeat

# To draw the line perpendicular to a given line at a given point

## Using Compass

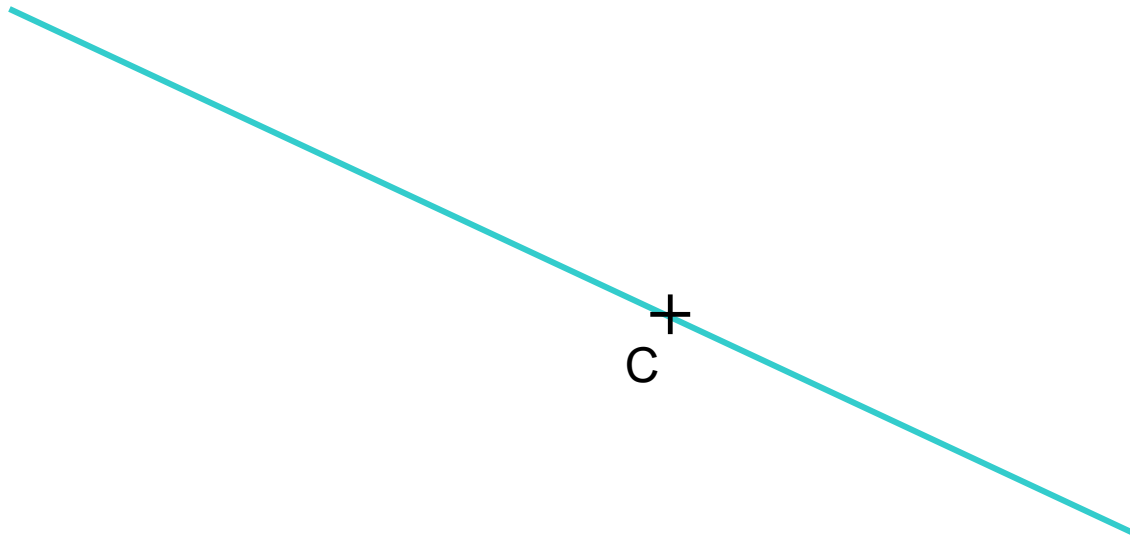

# To draw the line perpendicular to a given line at a given point

## Using Compass

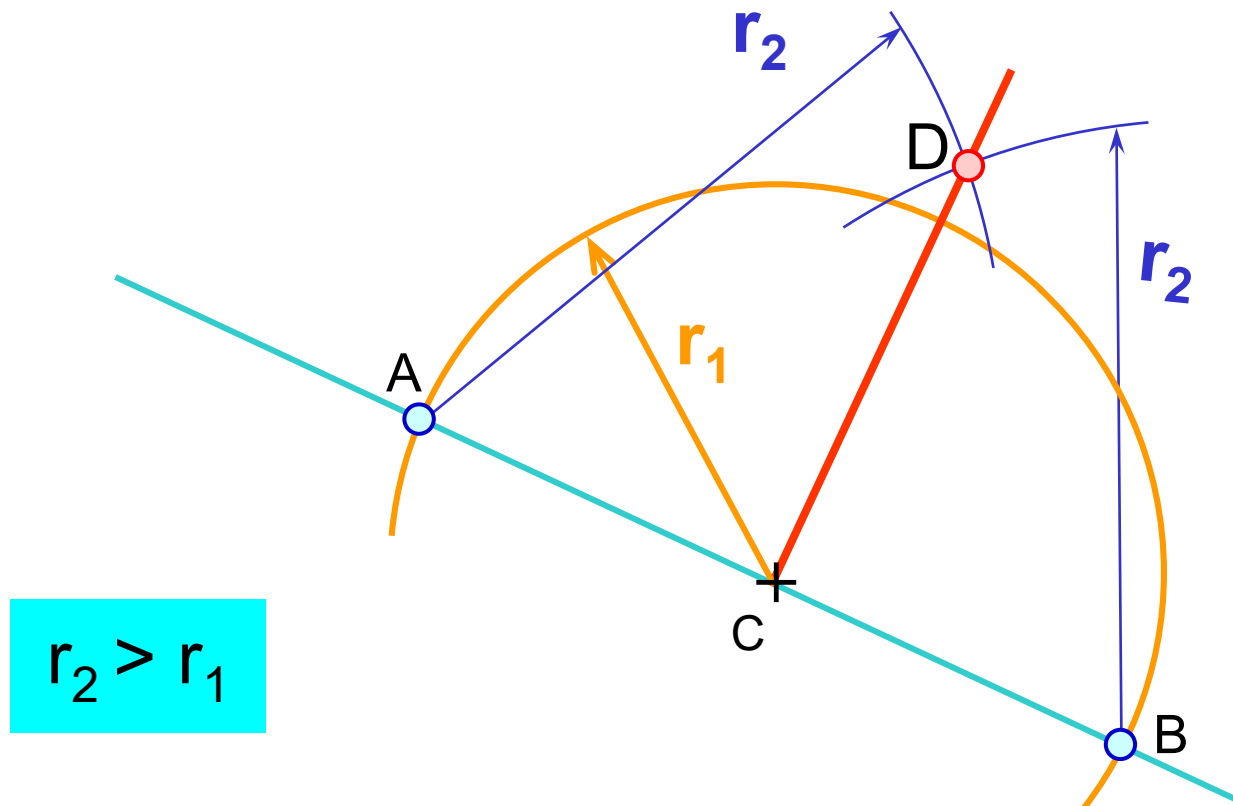

$$r_2 > r_1$$



# To draw the line perpendicular to a given line from a point not on the line

## Adjacent-sides method

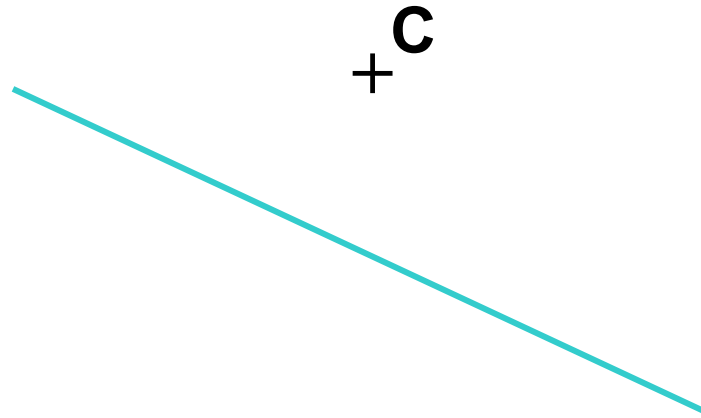

# To draw the line perpendicular to a given line from a point not on the line

## Adjacent-sides method

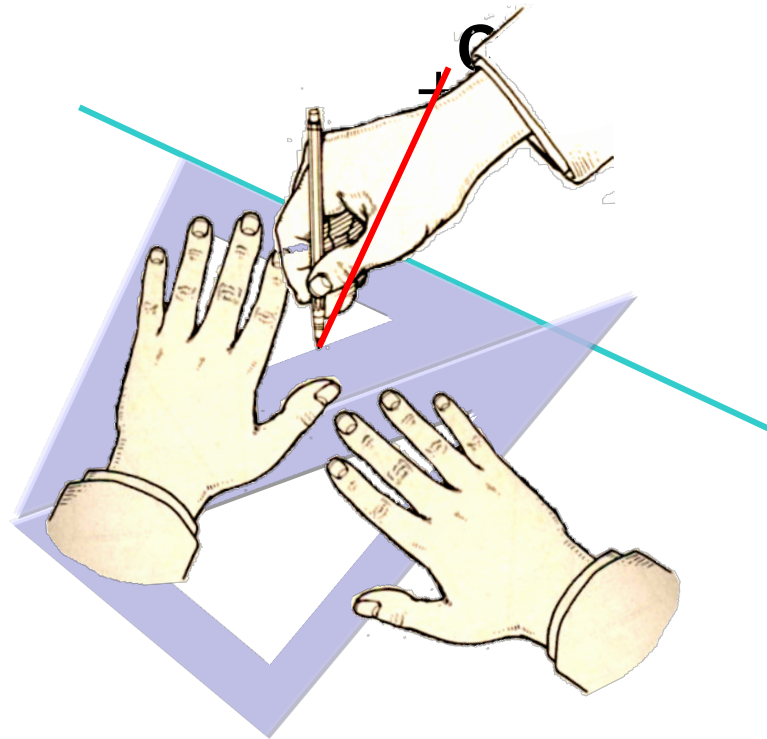

<https://civinnovate.com/civil-engineering-notes/>



Repeat

# To draw the line perpendicular to a given line from a point not on the line

Using compass

+ C

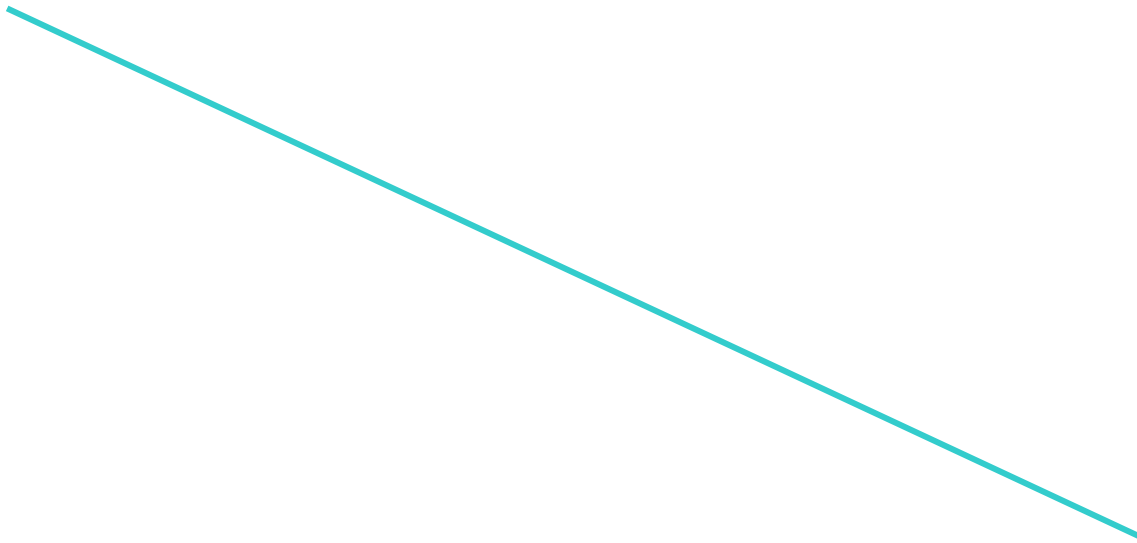

# To draw the line perpendicular to a given line from a point not on the line

Using compass

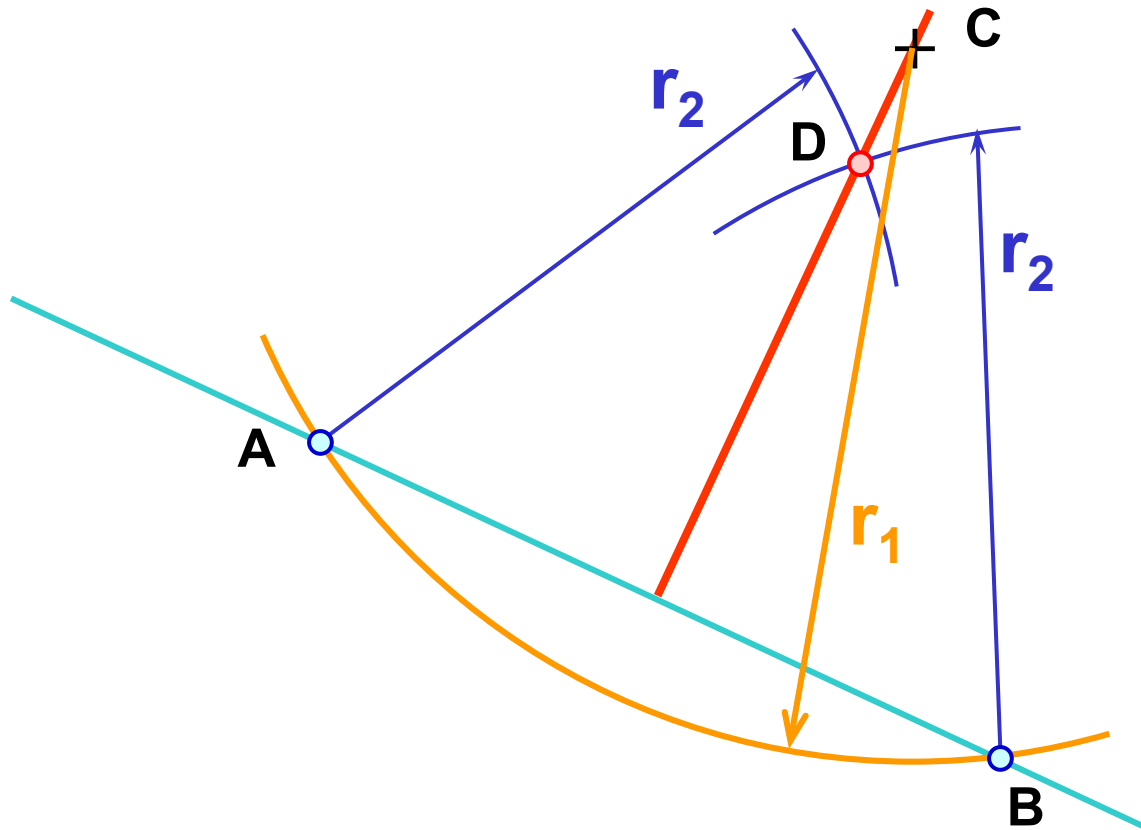

Note:

You can also use revolve method. How ? Try by yourself !!!

<https://civinnovate.com/civil-engineering-notes/>



Repeat

# To draw a line making $15^\circ$ with a given line and pass through a given point.

**Given**

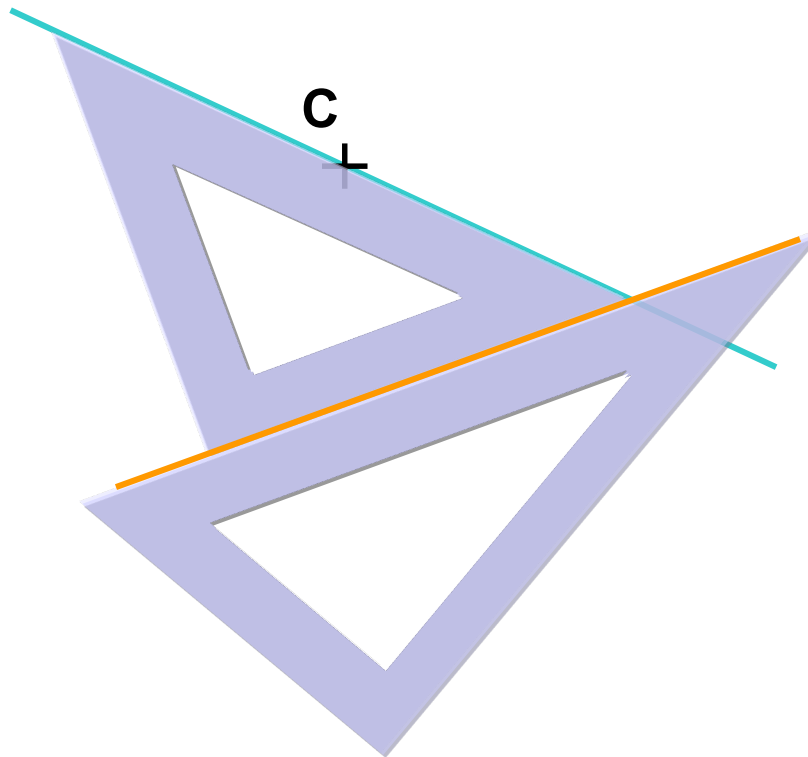



# To draw a line making $15^\circ$ with a given line and pass through a given point.

**Given**

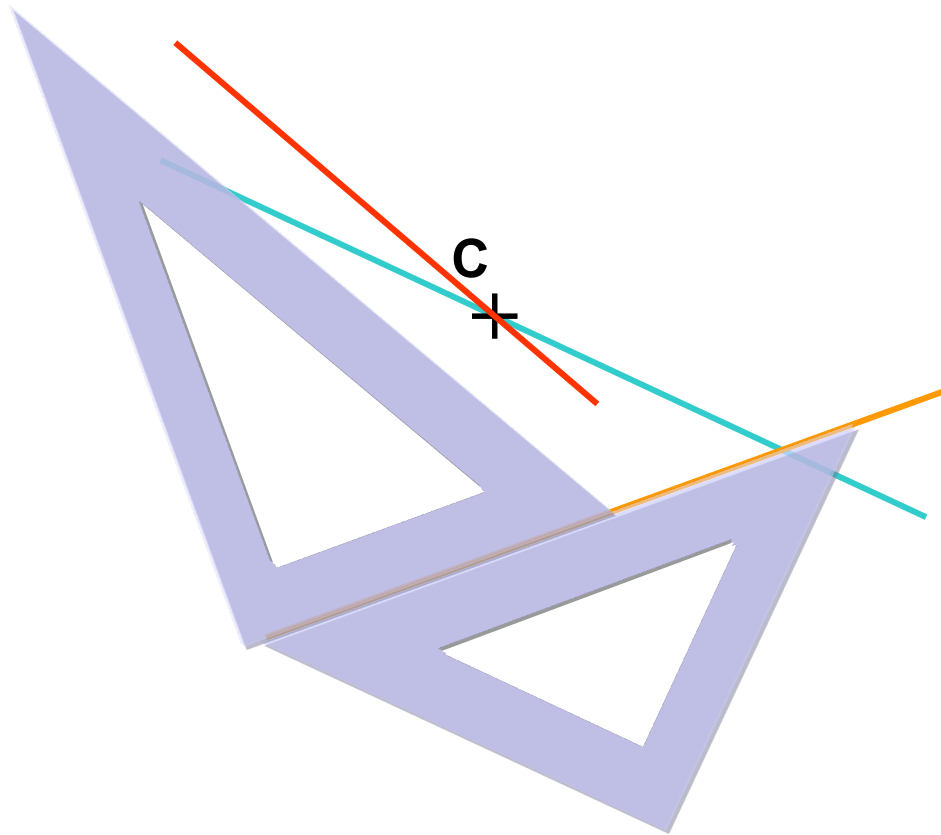

# To draw a line making $30^\circ$ with a given line and pass through a given point.

**Given**

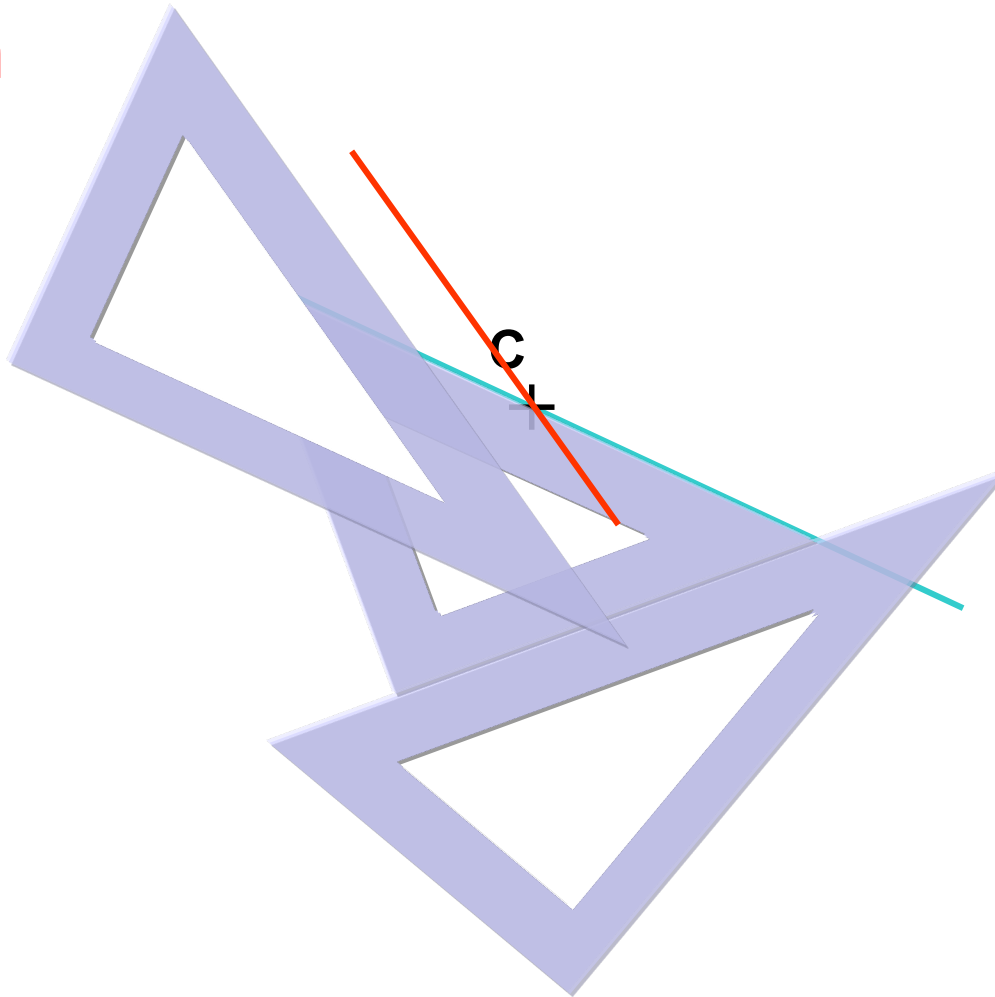

# To draw a line making $75^\circ$ with a given line and pass through a given point.

**Given**

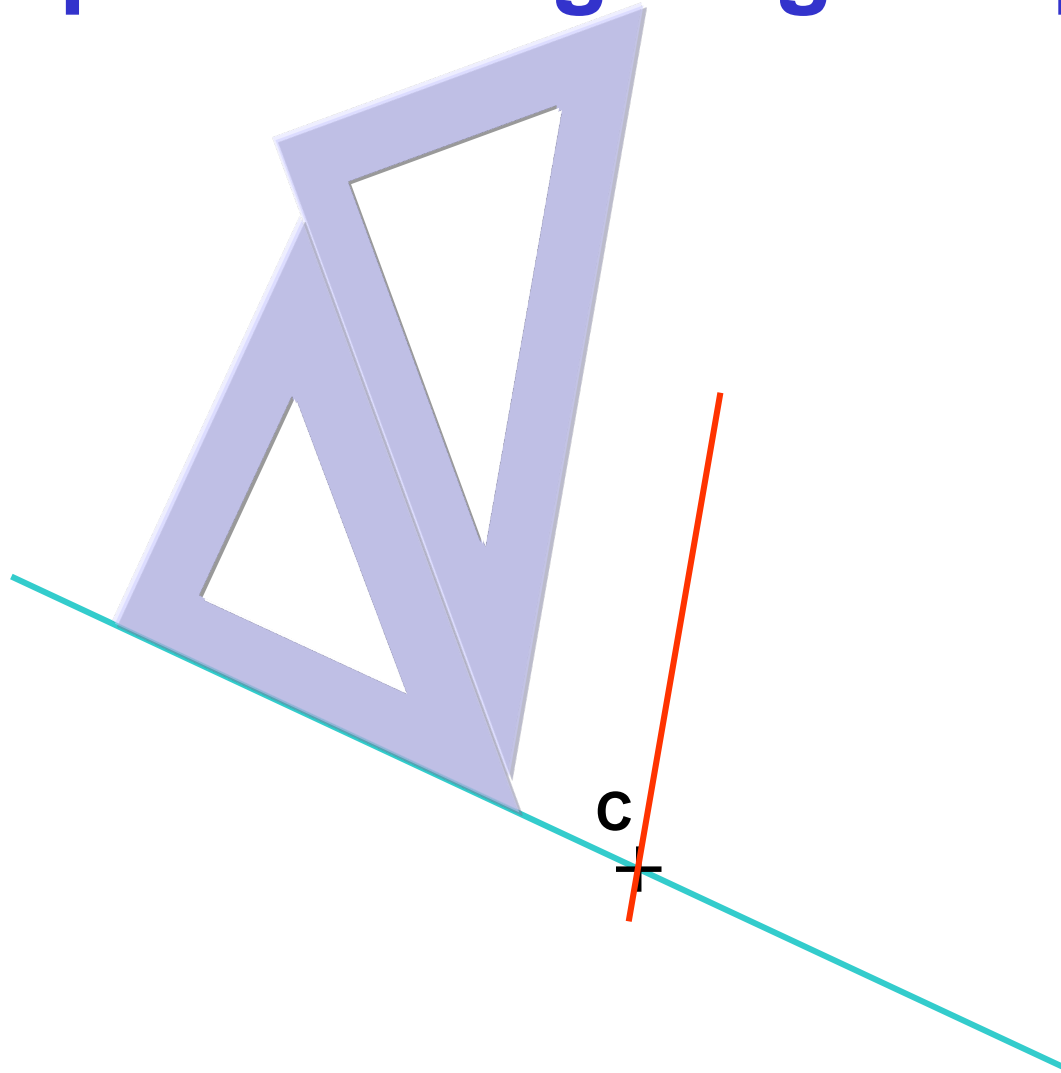

# FILLET AND ROUND

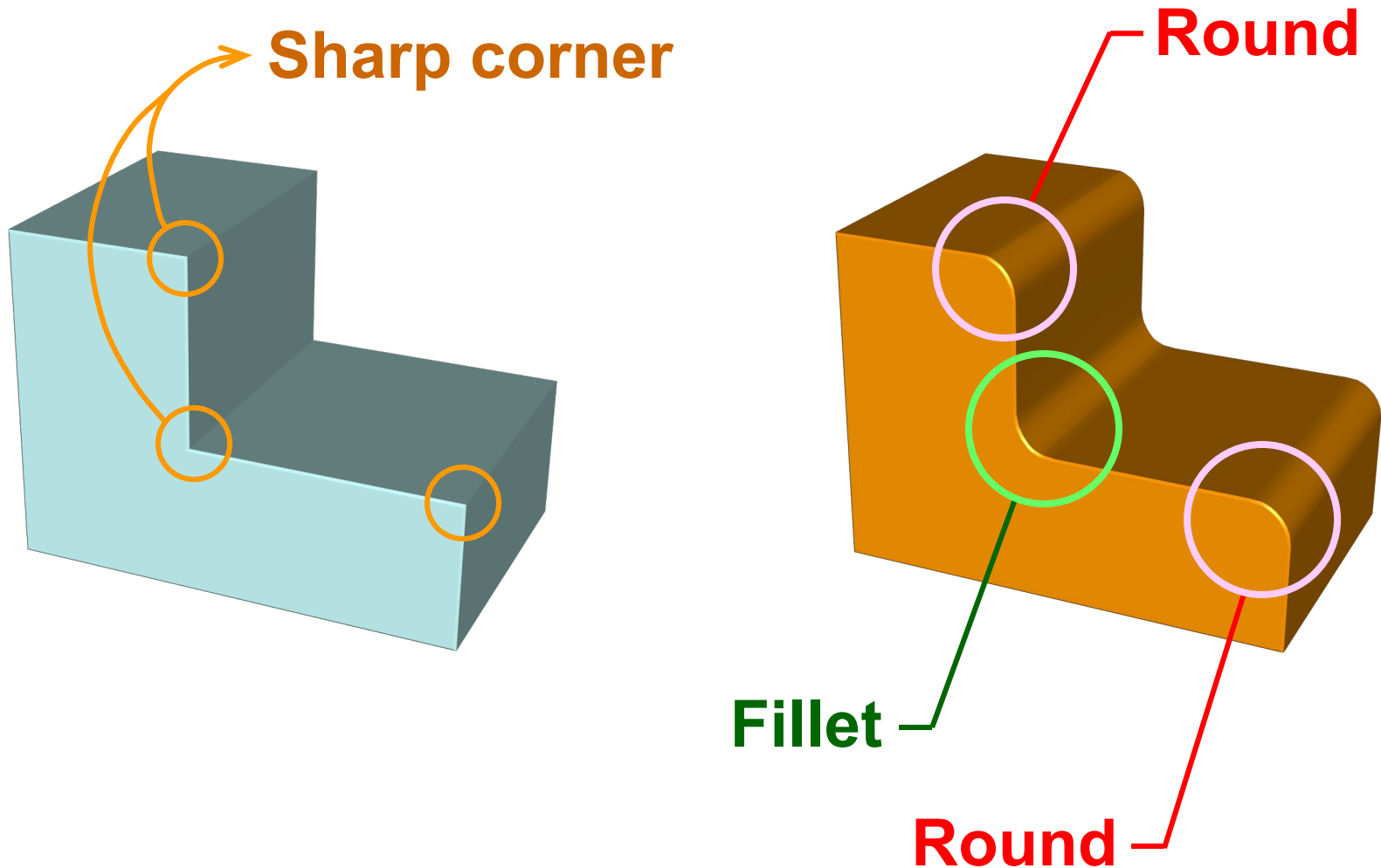

# FILLET AND ROUND

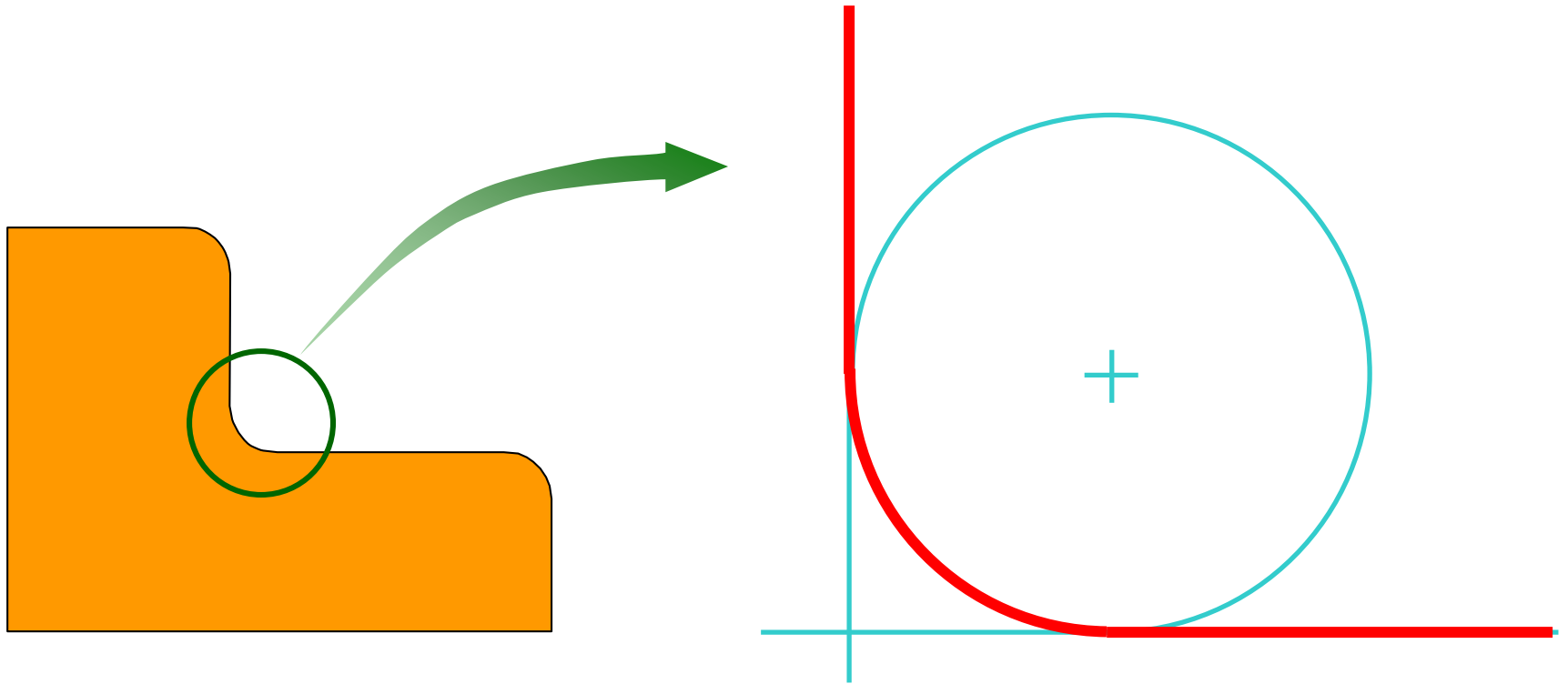

**To draw the arc, we must find the location of the center of that arc.**

***How do we find the center of the arc?***

<https://civinnovate.com/civil-engineering-notes/>

# To draw an arc of given radius tangent to two perpendicular lines

**Given** arc radius  $r$

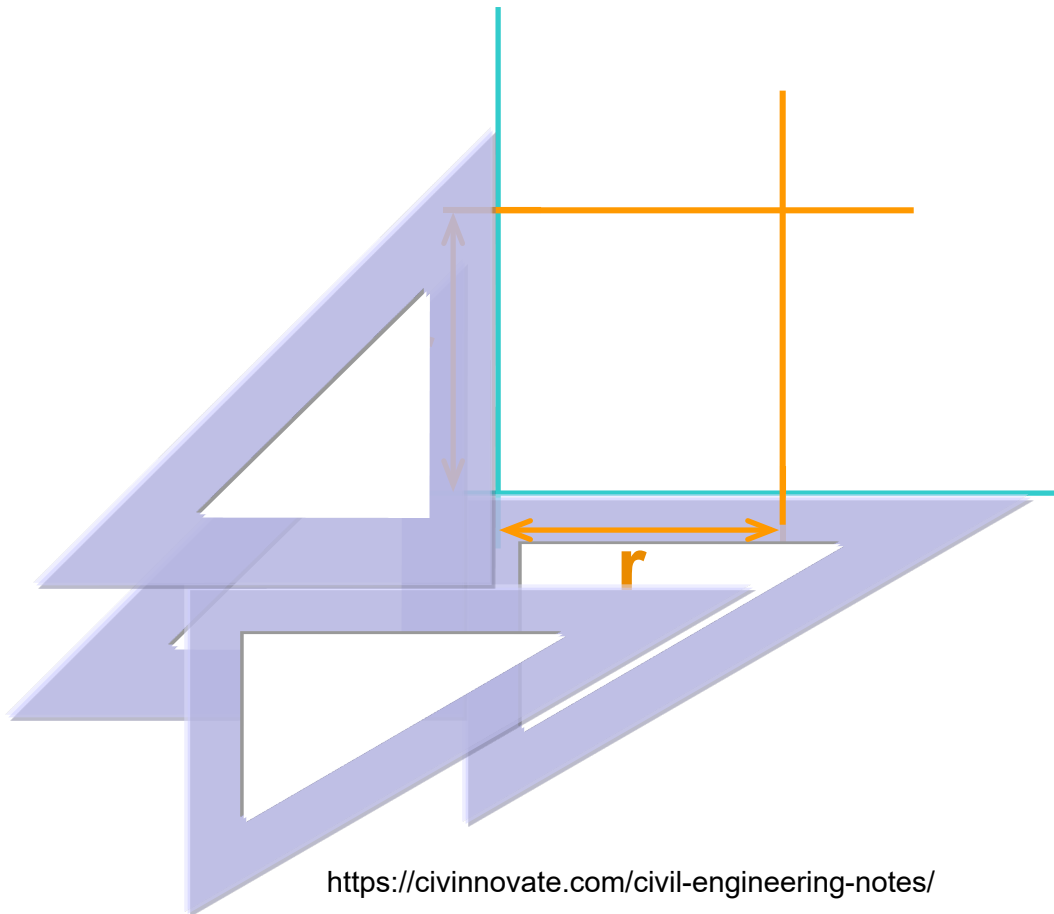

# To draw an arc of given radius tangent to two perpendicular lines

**Given** arc radius  $r$

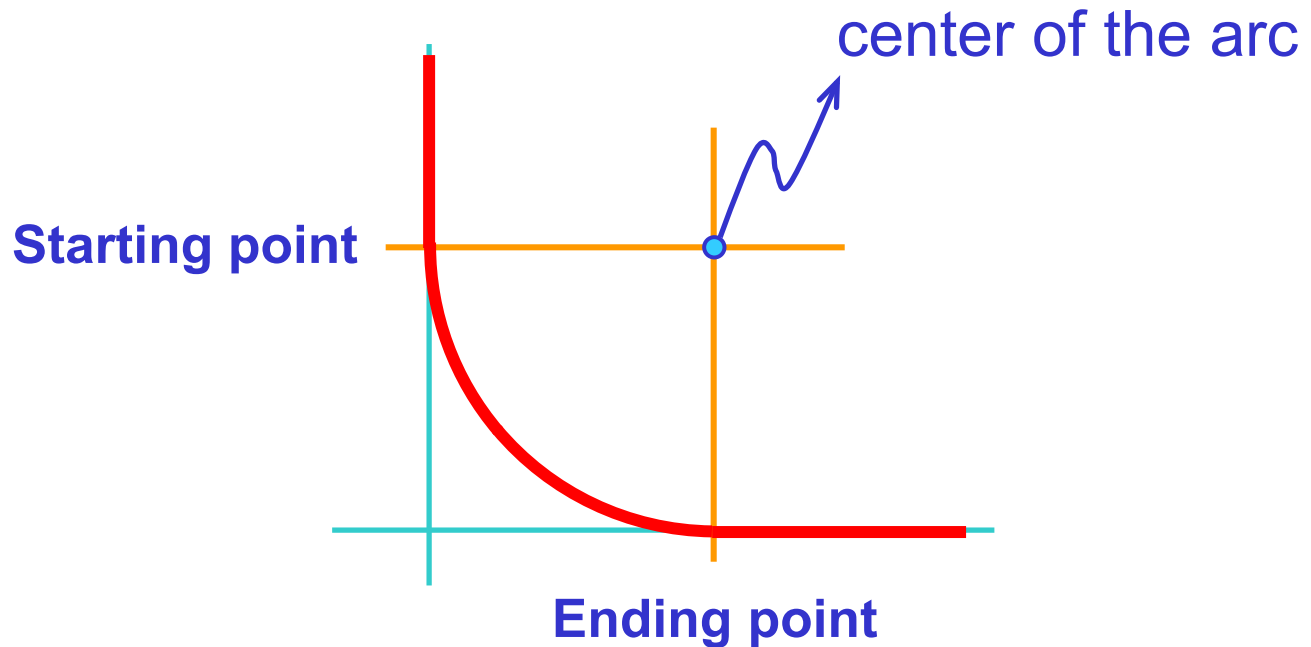

# To draw an arc of given radius tangent to two lines

**Given** arc radius  $r$

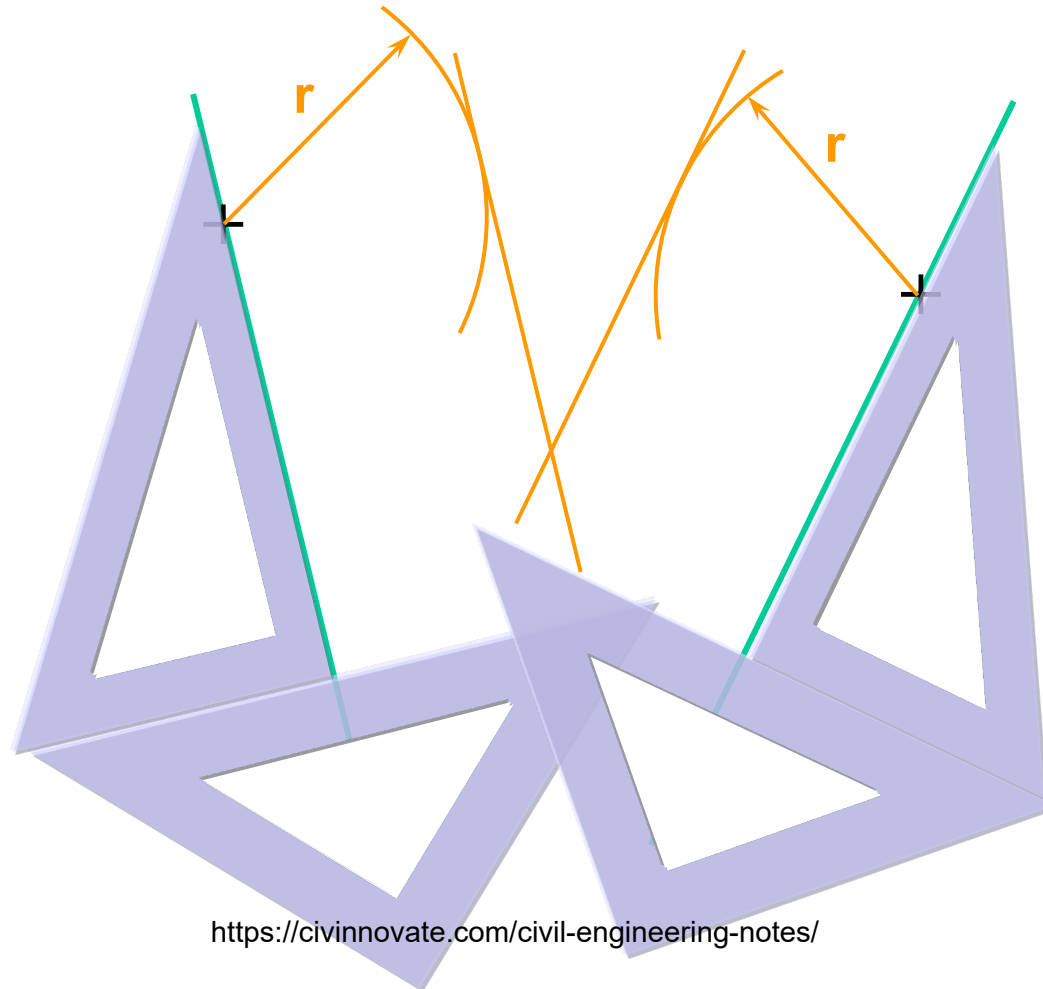



# To draw an arc of given radius tangent to two lines

**Given** arc radius  $r$

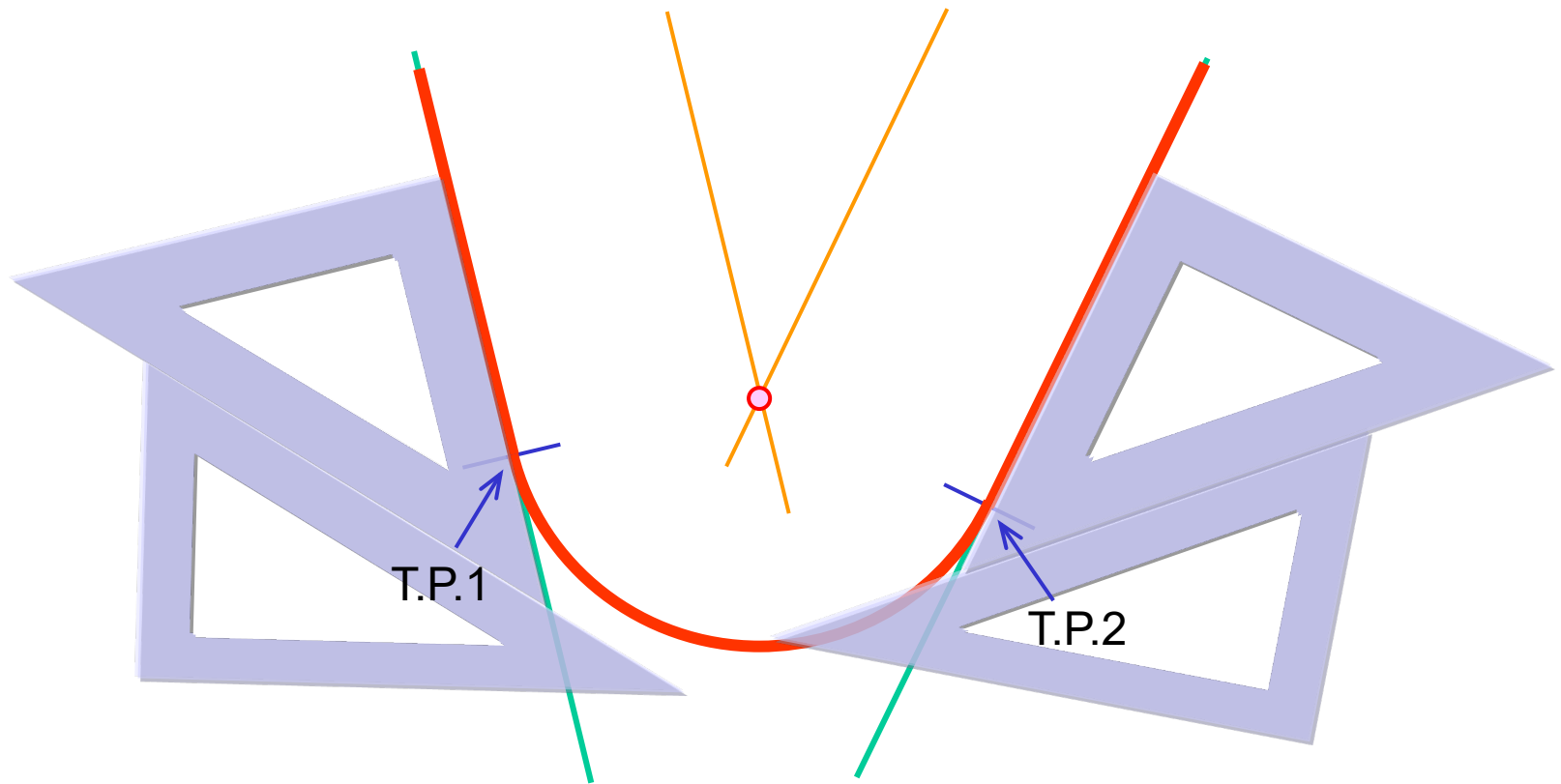

# To draw a line tangent to a circle at a point on the circle

**Given**

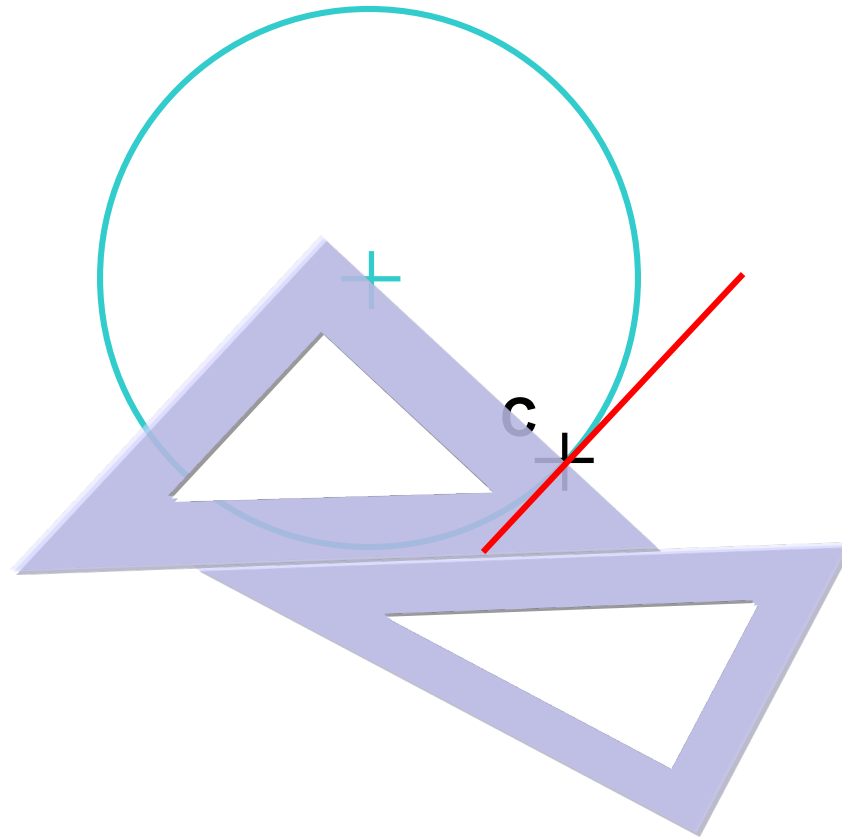

# To draw a line tangent to a circle from a point outside the circle

**Given**

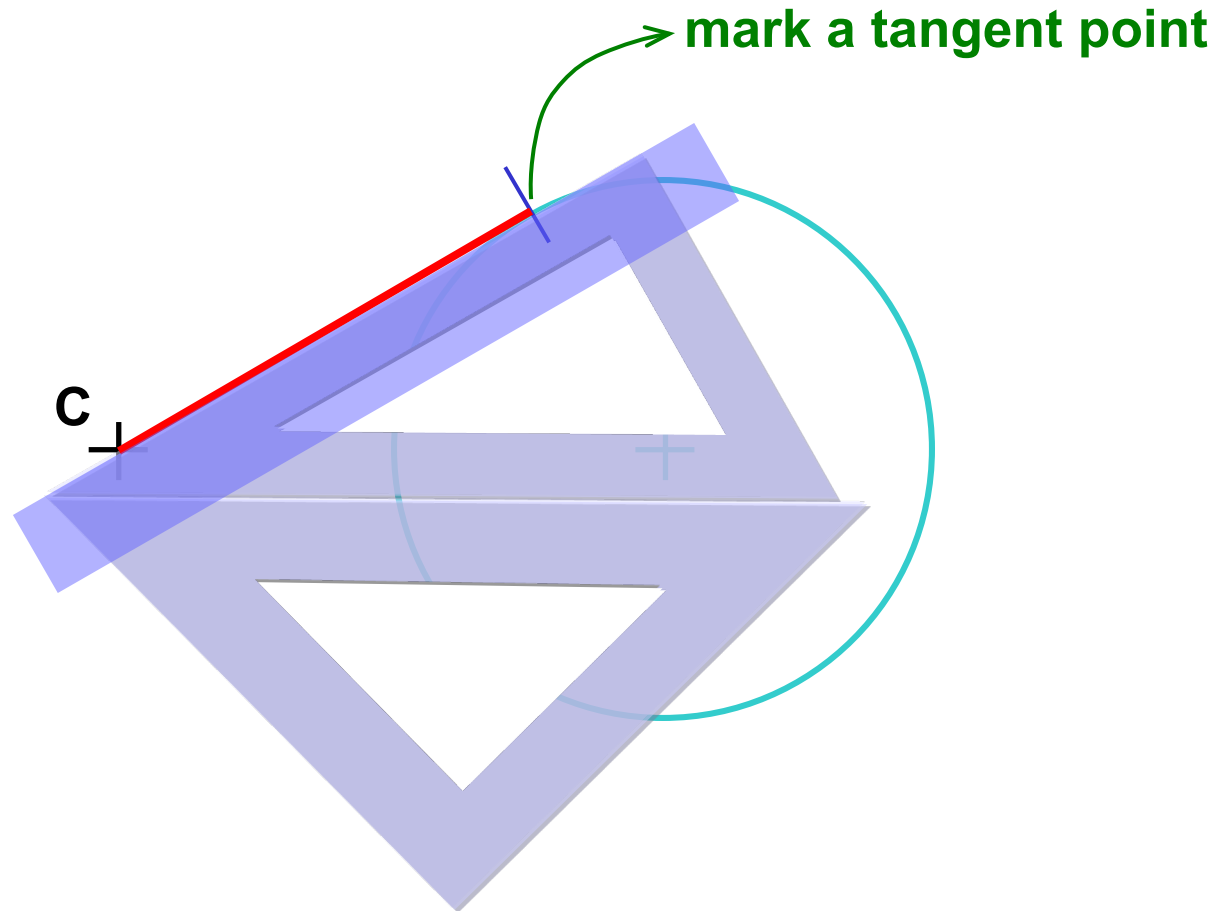

# When circle tangent to other circle

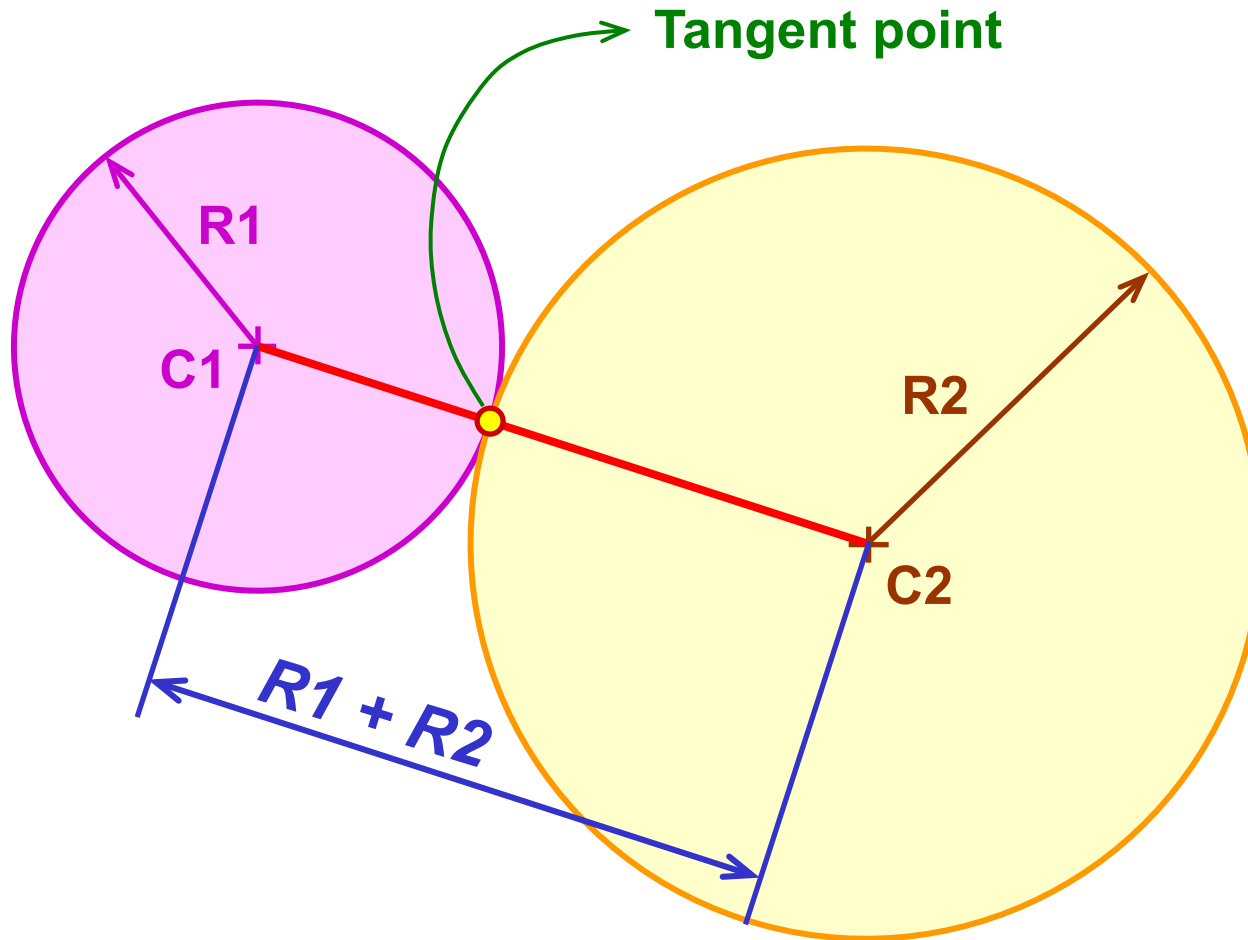

**The center of two circles and tangent point lie on the same straight line !!!**

# To draw a circle tangent to two circles I

**Given**

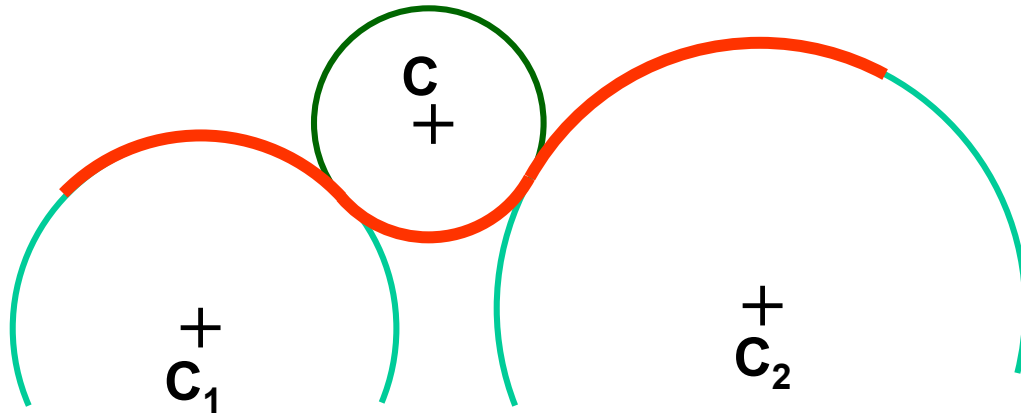

**Example**

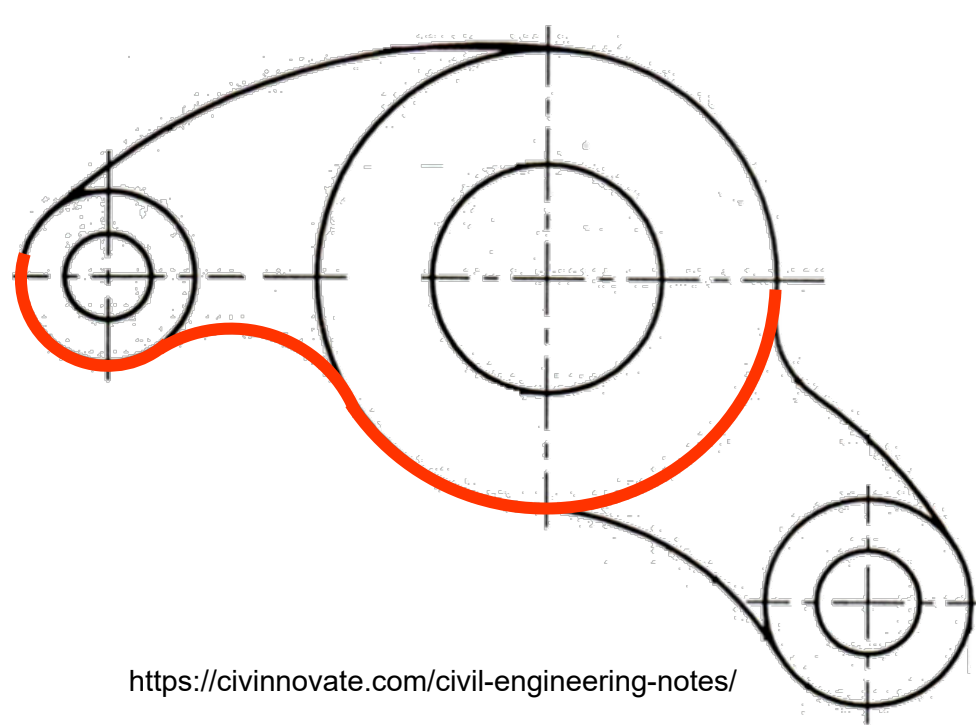

# To draw a circle tangent to two circles I

**Given** Two circles and the radius of the third circle = R

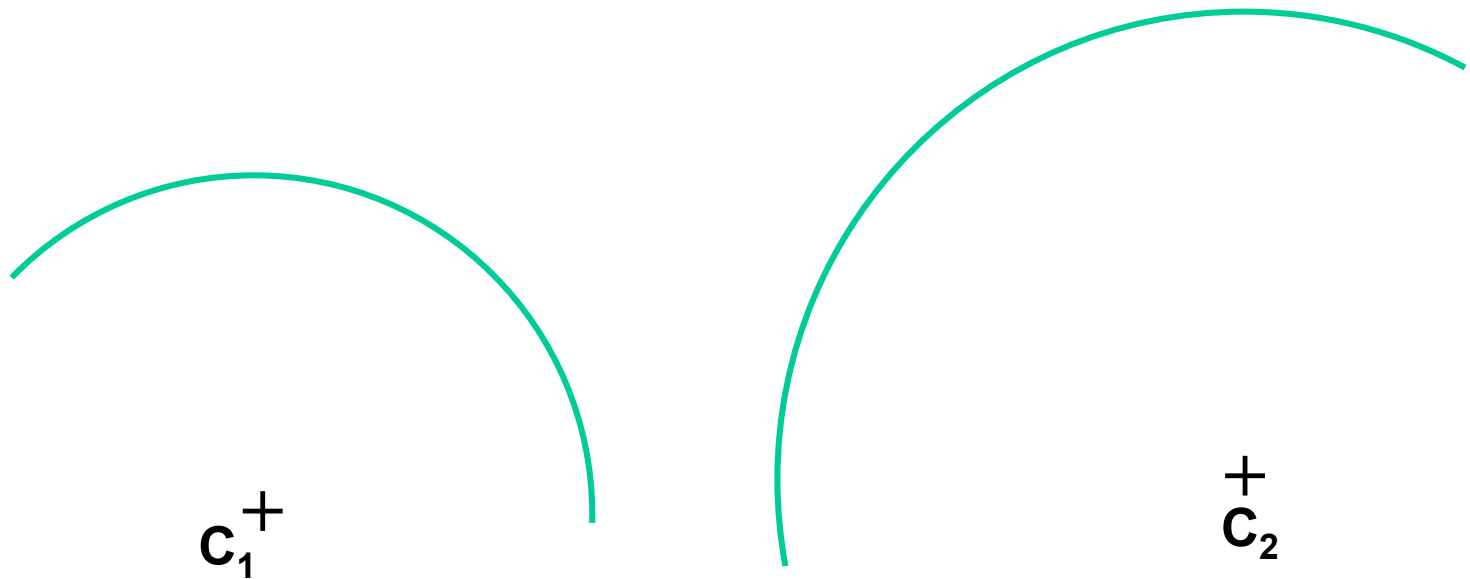

# To draw a circle tangent to two circles I

**Given** Two circles and the radius of the third circle =  $R$

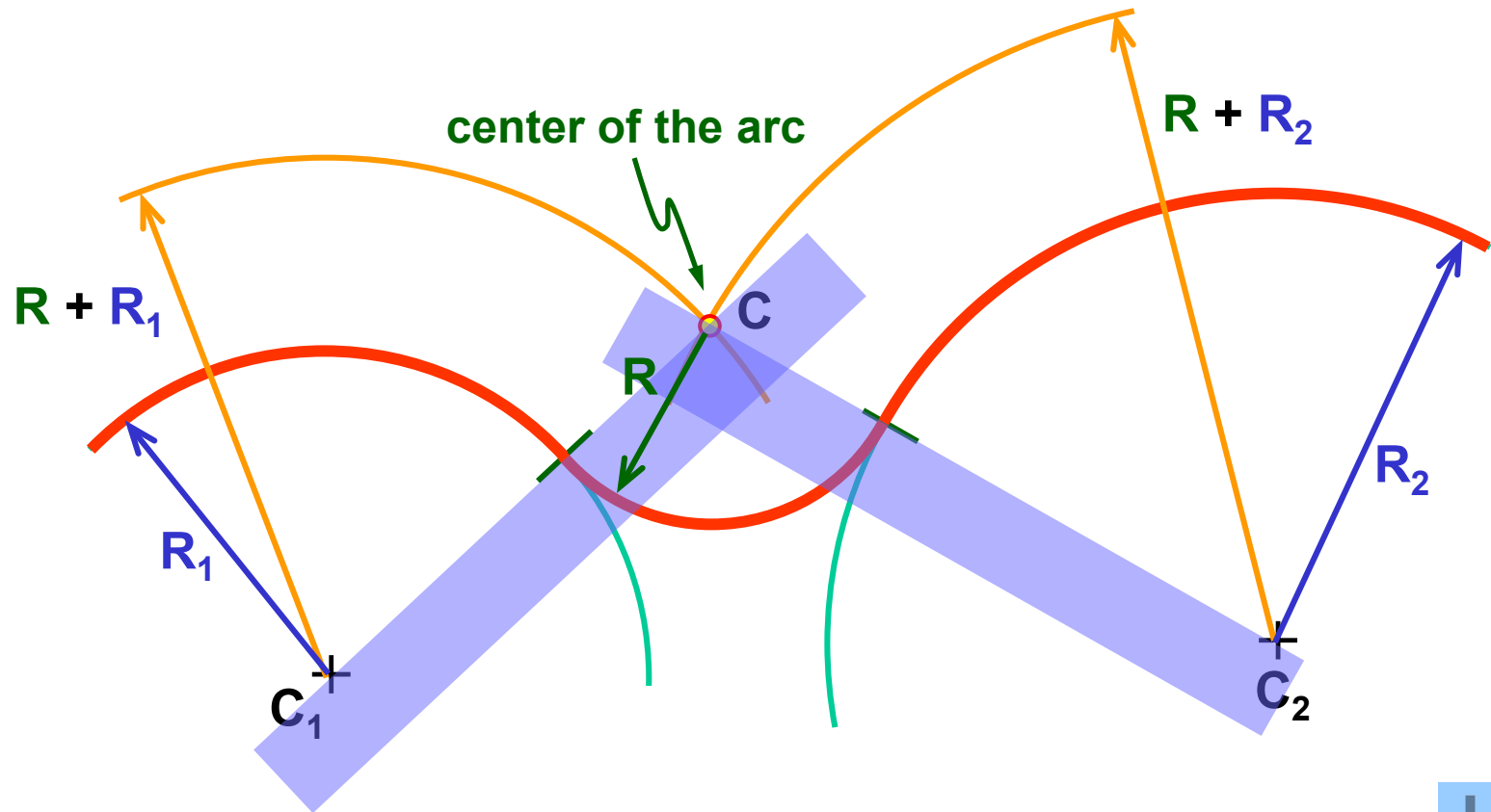

# When circle tangent to other circle

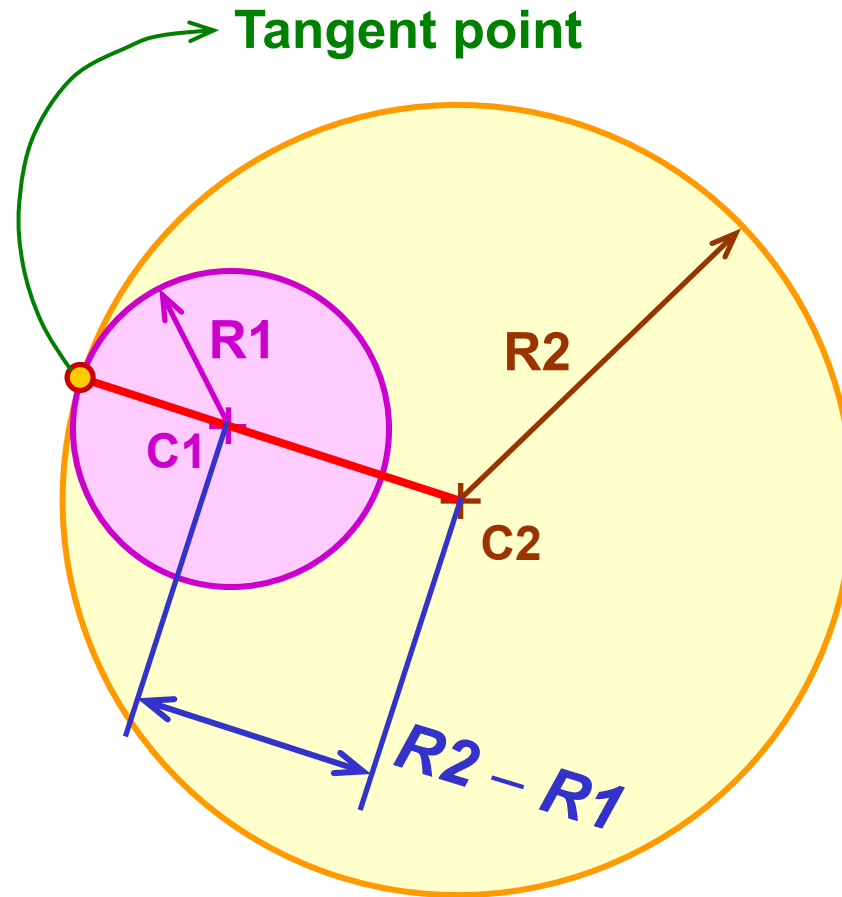

**The center of two circles and tangent point must lie on the same straight line !!!**



# To draw a circle tangent to two circles II

**Given**

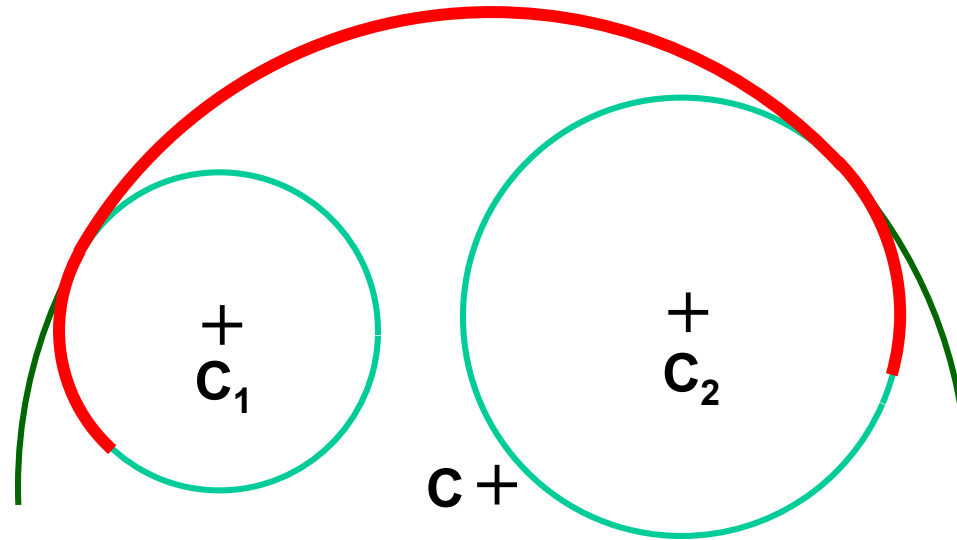

**Example**

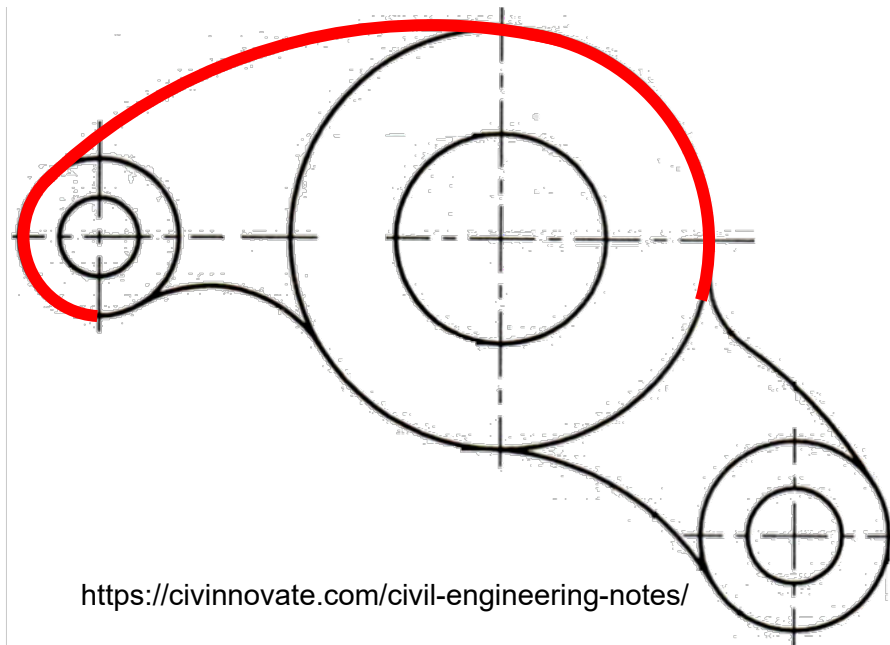

# To draw a circle tangent to two circles II

**Given** Two circles and the radius of the third circle = R

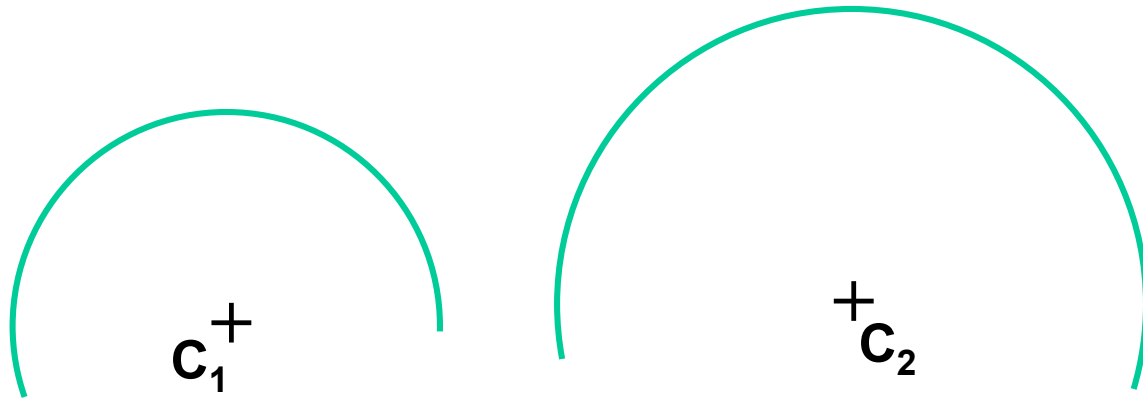

# To draw a circle tangent to two circles II

**Given** Two circles and the radius of the third circle =  $R$

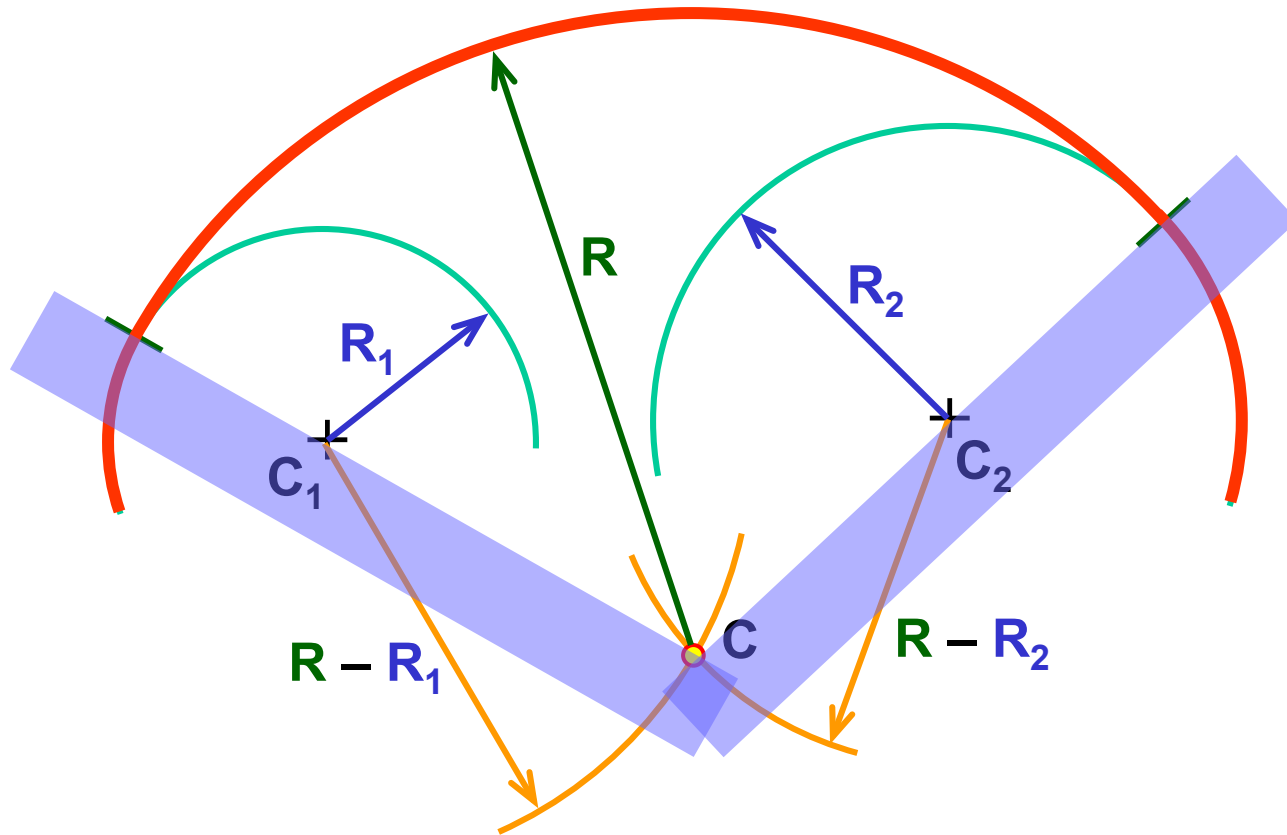

# To draw a circle tangent to two circles III

**Given** Two circles and the radius of the third circle =  $R$

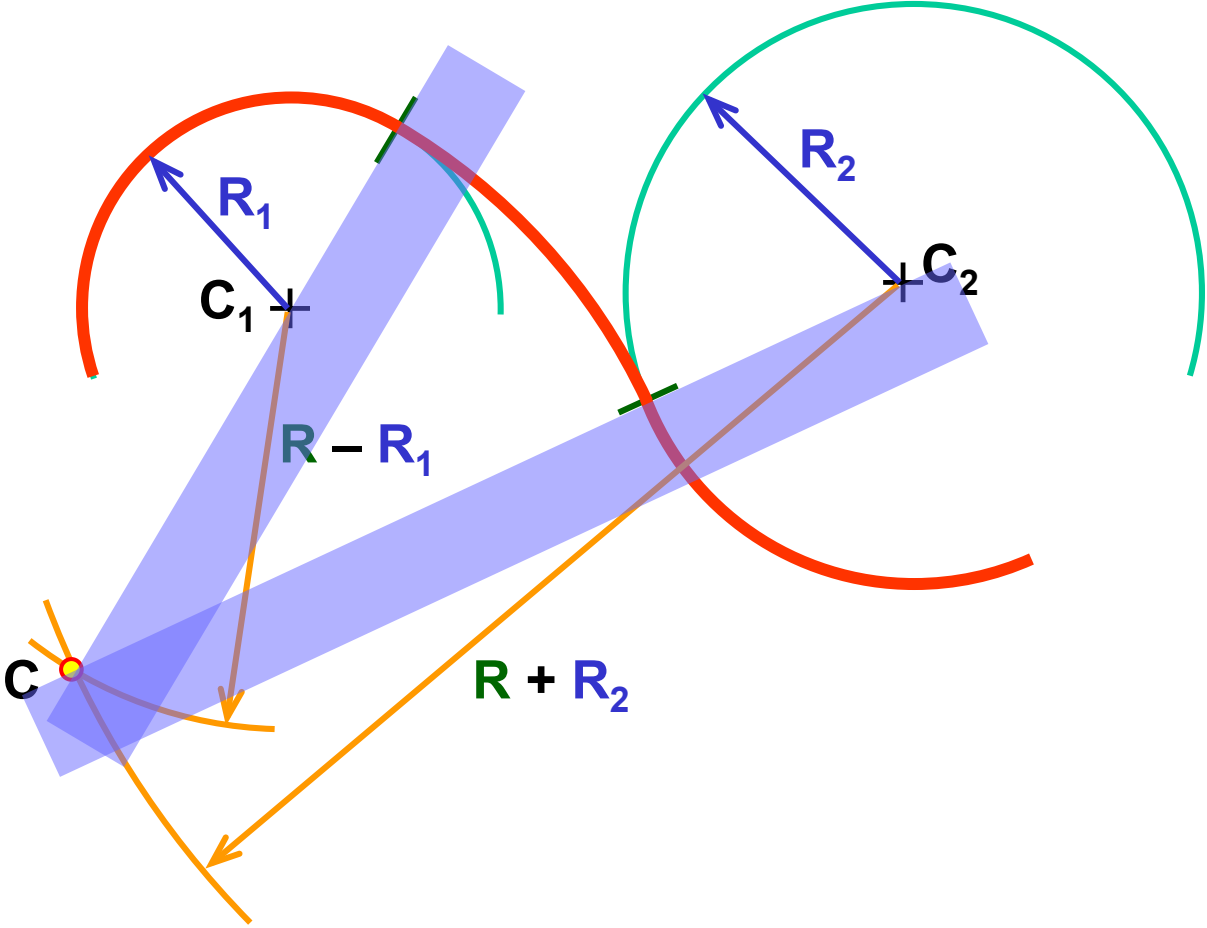

# To draw an approximate ellipse

**Given** Major and minor axes

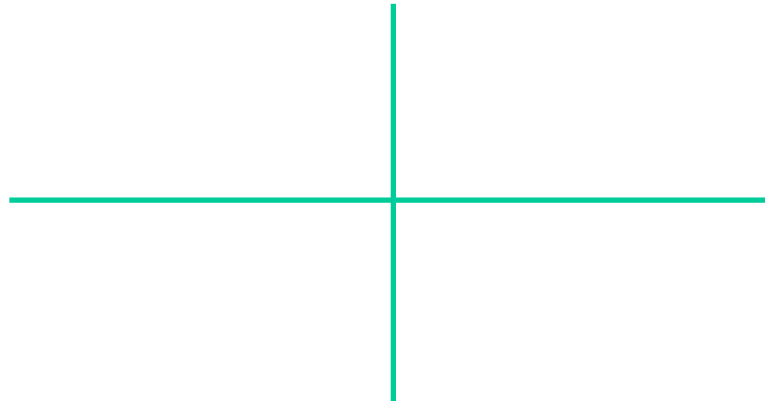

# To draw an approximate ellipse

**Given** Major and minor axes

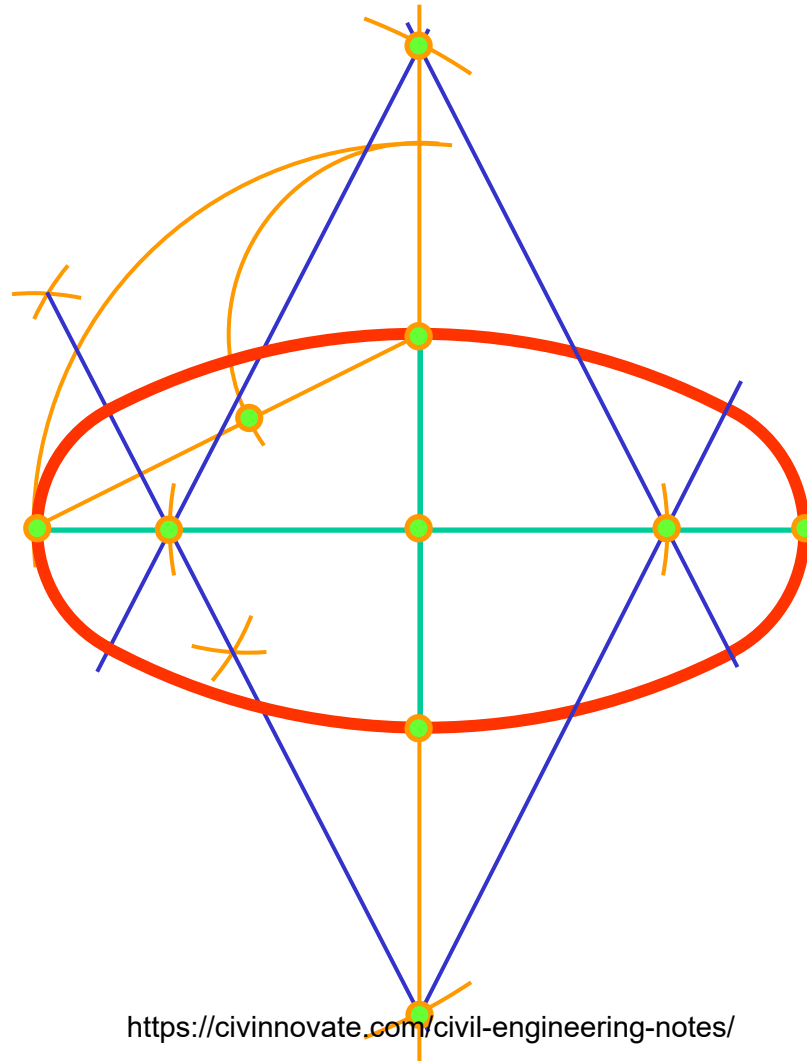

<https://civinnovate.com/civil-engineering-notes/>



**Repeat**

# How to Keep Your Drawing Clean

Do

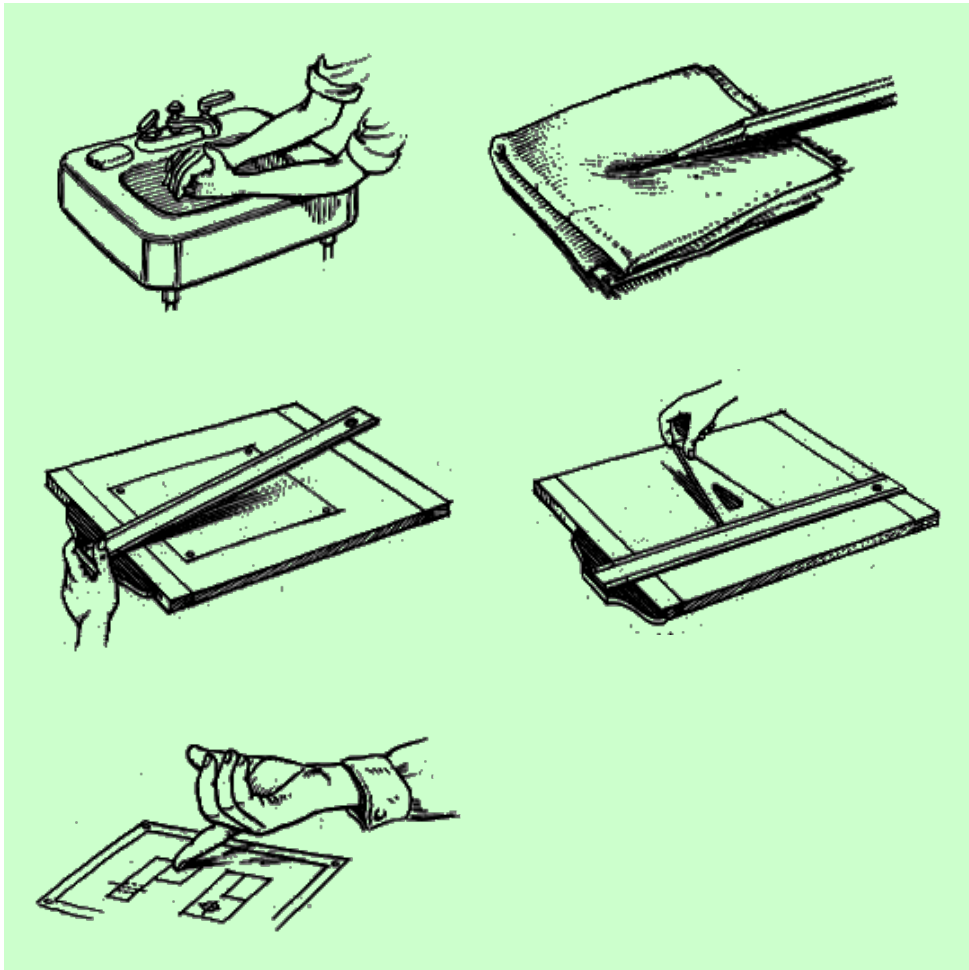

Don't

